

March 2011



# HVAC DESIGN MANUAL

**For:**

- Community Living Center
- Domiciliary

**Department of  
Veterans Affairs**



Office of Construction & Facilities Management  
Facilities Quality Service (00CFM)  
811 Vermont Avenue, NW  
Washington DC 20005





## **Acknowledgements**

The following individuals are those whose guidance, insight, advice and expertise made the update and revision of the HVAC Design Manual possible:

Lloyd H. Siegel, FIIA  
Director, Strategic Management Office (00CFM1)  
VA Office of Construction and Facilities Management  
Washington DC

Kurt D. Knight, PE  
Chief, Facilities Quality Service (00CFM1A)  
Strategic Management Office  
VA Office of Construction and Facilities Management  
Washington DC

Mulraj (Manu) P. Dhokai, PE  
Senior Mechanical Engineer (00CFM1A)  
Facilities Quality Service  
Strategic Management Office  
VA Office of Construction and Facilities Management  
Washington DC

### **Consultant GLHN Architects and Engineers, Inc**

William Nelson, PE  
President - Project Principal  
Tucson, AZ

Carol Larson, PE, CEM, LEED AP  
Mechanical Department Manager - Project Executive  
Tucson, AZ

This page intentionally left blank.

Table of Contents

CHAPTER 1: BASIC REQUIREMENTS.....	1-1
1.1    INTRODUCTION.....	1-2
1.2    COMMUNITY LIVING CENTER (CLC).....	1-2
1.2.1    GENERAL.....	1-2
1.2.2    HOME.....	1-2
1.2.3    COMMUNITY CENTER.....	1-2
1.2.4    COMMUNITY CENTER – OPTIONAL SPACES.....	1-2
1.2.5    COMMUNITY CENTER – MISCELLANEOUS SPACES.....	1-2
1.3    DOMICILIARY (DOM).....	1-2
1.4    COMPLIANCE.....	1-3
1.5    ENERGY CONSERVATION.....	1-3
1.5.1    ASHRAE STANDARD 90.1 – 2007.....	1-3
1.6    MANDATED ENERGY CONSERVATION MEASURES.....	1-3
1.6.1    LIFE-CYCLE COST ANALYSIS – REQUIREMENTS.....	1-4
1.6.2    LIFE-CYCLE COST ANALYSIS – METHODOLOGY.....	1-4
1.6.3    ENERGY REDUCTION REQUIREMENT – NEW CONSTRUCTION.....	1-4
1.6.4    ENERGY REDUCTION REQUIREMENT – MAJOR RENOVATIONS.....	1-4
1.7    MEASUREMENT AND VERIFICATION.....	1-4
1.8    APPLICABLE CODES AND STANDARDS.....	1-5
1.9    COMMISSIONING.....	1-5
1.10    VA STANDARDS.....	1-5
1.10.1    DESIGN MANUALS (by discipline) (PG-18-10).....	1-5
1.10.2    MINIMUM REQUIREMENTS FOR A/E SUBMISSIONS (PG-18-15).....	1-6
1.10.3    MASTER CONSTRUCTION SPECIFICATIONS (PG-18-1).....	1-6
1.10.4    ARCHITECT/ENGINEER REVIEW CHECKLIST.....	1-6
1.10.5    DESIGN ALERTS.....	1-7
1.10.6    A/E QUALITY ALERTS.....	1-7
1.10.7    DESIGN GUIDES (graphical, by function) (PG-18-12).....	1-7
1.10.8    DESIGN AND CONSTRUCTION PROCEDURES (PG-18-3).....	1-7
1.10.9    STANDARD DETAILS AND CAD STANDARDS (PG-18-4).....	1-8
1.10.10    PHYSICAL SECURITY DESIGN MANUAL FOR VA FACILITIES – MISSION CRITICAL FACILITIES AND LIFE SAFETY PROTECTED FACILITIES (FORMERLY CD-54).....	1-8
1.10.11    COST ESTIMATING MANUAL.....	1-8
1.10.12    SUSTAINABLE DESIGN AND ENERGY REDUCTION MANUAL.....	1-8
1.10.13    SEISMIC DESIGN REQUIREMENTS (STRUCTURAL) (H-18-18).....	1-9
1.10.14    FIRE PROTECTION DESIGN MANUAL.....	1-9
1.11    BUILDING INFORMATION MODEL (BIM) GUIDE.....	1-9
1.12    COMPUTER AIDED FACILITIES MANAGEMENT (CAFM).....	1-9
1.12.1    CAFM AND EQUIPMENT SCHEDULE UTILIZATION.....	1-9
1.13    HVAC DESIGN MANUAL AND A/E SUBMISSION REQUIREMENTS (PG-18-15).....	1-9
1.13.1    COORDINATION.....	1-9
1.13.2    COMPLIANCE REQUIREMENTS.....	1-10
1.13.3    EQUIPMENT SCHEDULES.....	1-10
1.13.3.1    Order of Presentation.....	1-10
1.13.3.2    Equipment Capacity and Performance Data Requirements.....	1-10
1.13.3.3    Equipment Schedules – Glycol Data.....	1-10
CHAPTER 2: HVAC DESIGN PARAMETERS AND SELECTION CRITERIA.....	2-1
2.1    INTRODUCTION.....	2-3
2.2    BASIS OF DESIGN.....	2-3
2.2.1    OUTDOOR DESIGN CONDITIONS.....	2-3
2.2.1.1    Cooling and Heating Load Calculations.....	2-3

2.2.1.2	Cooling Tower Selection .....	2-3
2.2.1.3	Preheat Coil Selection .....	2-3
2.2.1.4	Electrical Heating Devices Using Emergency Power .....	2-3
2.2.2	INDOOR DESIGN CONDITIONS .....	2-3
2.2.2.1	General.....	2-3
2.2.2.2	Indoor Space Temperature .....	2-3
2.2.2.3	Indoor Space Relative Humidity – Dehumidification .....	2-4
2.2.2.4	Indoor Space Relative Humidity – Humidification.....	2-4
2.2.3	ROOM AIR BALANCE .....	2-4
2.2.3.1	General.....	2-4
2.2.3.2	Neutral (o) Air Balance.....	2-4
2.2.3.3	Negative (-) Air Balance.....	2-5
2.2.3.4	Double Negative (- -) Air Balance .....	2-5
2.2.3.5	Positive (+) Air Balance .....	2-5
2.2.3.6	Double Positive (+ +) Air Balance .....	2-5
2.2.4	OCCUPANCY.....	2-5
2.2.5	LIGHT AND POWER LOAD.....	2-5
2.2.6	BUILDING THERMAL ENVELOPE.....	2-5
2.2.7	OUTDOOR AIR FOR VENTILATION (CALCULATION REQUIREMENTS) .....	2-5
2.3	COOLING AND HEATING LOAD CALCULATIONS .....	2-6
2.3.1	ROOM DATA OUTPUT .....	2-6
2.3.2	AHU DATA OUTPUT.....	2-6
2.3.2.1	AHU Peak Cooling Load.....	2-6
2.3.2.2	AHU Peak Supply Air Volume.....	2-6
2.3.2.3	AHU Supply Air Volume and Duct Leakage Factor .....	2-6
2.3.2.4	Psychrometric Analysis.....	2-7
2.3.3	BUILDING PEAK COOLING LOAD .....	2-7
2.4	ROOM TEMPERATURE CONTROLS.....	2-7
2.4.1	DEFINITION .....	2-7
2.4.1.1	Individually Controlled Rooms.....	2-7
2.4.1.2	Group Temperature Control – Perimeter Offices.....	2-7
2.4.1.3	Group Temperature Control – Interior Offices .....	2-7
2.4.1.4	Open Spaces.....	2-7
2.4.2	PERIMETER HEATING REQUIREMENTS.....	2-8
2.4.2.1	General.....	2-8
2.4.2.2	Perimeter Heating System Description .....	2-8
2.4.2.3	Heating Medium.....	2-8
2.4.2.4	System Sizing and Control Criteria .....	2-8
2.5	SPECIAL STUDIES REQUIREMENTS.....	2-8
2.5.1	ACOUSTIC ANALYSIS.....	2-8
2.5.1.1	General.....	2-8
2.5.1.2	Acoustic Mitigation Measures (HVAC Systems – Without Cooling Tower) .....	2-9
2.5.1.3	Acoustic Mitigation Measures (HVAC Systems – With Cooling Towers) .....	2-9
2.5.1.4	Unitary Equipment .....	2-9
2.5.2	DISPERSION ANALYSIS .....	2-10
2.5.2.1	General.....	2-10
2.5.2.2	Scope of Work .....	2-10
2.5.3	BUILDING THERMAL ENVELOPE (EXISTING FACILITIES ONLY).....	2-10
2.6	VIBRATION CONTROL.....	2-10
2.7	SEISMIC REQUIREMENTS (HVAC) .....	2-10
2.7.1	COMPLIANCE .....	2-10
2.7.2	APPLICATIONS.....	2-10
2.7.2.1	New Buildings.....	2-10

## Table of Contents

2.7.2.2	Existing Buildings.....	2-10
2.7.2.3	New and Existing Buildings – Piping.....	2-11
2.7.2.4	Local Codes.....	2-11
2.7.2.5	Omissions.....	2-11
2.7.3	CONFORMANCE WITH SMACNA .....	2-11
2.7.4	CALCULATIONS .....	2-11
2.7.5	DRAWINGS.....	2-11
2.7.5.1	General.....	2-11
2.7.5.2	Ductwork and Piping Plans and Sections.....	2-11
2.7.5.3	Equipment Restraints.....	2-11
2.8	FIRE AND SMOKE PROTECTION.....	2-11
2.8.1	COMPLIANCE .....	2-11
2.8.2	ADDITIONAL REQUIREMENTS.....	2-12
2.8.2.1	Smoke Dampers.....	2-12
2.8.3	STAIR PRESSURIZATION.....	2-12
2.8.4	ENGINEERED SMOKE CONTROL SYSTEM .....	2-12
2.8.5	ATRIUM SMOKE CONTROL.....	2-12
2.8.6	ELEVATOR SHAFT VENTING .....	2-12
2.8.6.1	Compliance.....	2-12
2.8.6.2	Hardware.....	2-12
2.9	DESIGN CONSIDERATIONS FOR EXISTING BUILDINGS .....	2-12
2.9.1	SITE SURVEY .....	2-12
2.9.1.1	As-Built Drawings .....	2-12
2.9.1.2	Site Visits.....	2-13
2.9.2	MODIFICATIONS – EXISTING SYSTEMS.....	2-13
2.9.2.1	Steam Radiators.....	2-13
2.9.2.2	DDC Controls .....	2-13
2.9.2.3	Existing Ductwork .....	2-13
2.9.2.4	Refrigerant Removal.....	2-13
2.10	PROJECT PLANNING.....	2-13
2.10.1	PHASING .....	2-13
2.10.2	UTILITY CONNECTIONS AND OUTAGES .....	2-13
2.11	TECHNICAL CONSIDERATIONS.....	2-14
2.11.1	DEMOLITION WORK .....	2-14
2.12	LOCATIONS OF OUTDOOR AIR INTAKES AND EXHAUST AIR OUTLETS.....	2-14
2.12.1	COMPLIANCE – PHYSICAL SECURITY.....	2-14
2.12.2	GENERAL .....	2-14
2.12.3	COMMON OUTDOOR AIR INTAKE .....	2-14
2.13	BID PACKAGE COORDINATION.....	2-14
CHAPTER 3:	AIRSIDE HVAC SYSTEMS AND EQUIPMENT.....	3-1
3.1	INTRODUCTION.....	3-5
3.1.1	HVAC SYSTEMS.....	3-5
3.2	CENTRAL AIR-HANDLING UNITS (ALL-AIR SYSTEMS) .....	3-5
3.2.1	GENERAL .....	3-5
3.2.2	SPECIAL REQUIREMENTS.....	3-5
3.2.2.1	Terminal Cooling System.....	3-5
3.2.2.2	Blow-Through Air-Handling Units.....	3-6
3.2.2.3	Dual-Duct System.....	3-6
3.2.2.4	Limiting Capacity .....	3-6
3.2.2.5	AHU Configuration.....	3-6
3.2.2.6	Rooftop Air-Handling Units .....	3-6
3.3	AIR-HANDLING UNIT COMPONENTS .....	3-6

3.3.1	SUPPLY AIR FAN .....	3-6
3.3.1.1	General.....	3-6
3.3.1.2	Plenum Fans .....	3-6
3.3.1.3	Return Air Fan .....	3-6
3.3.1.4	Exhaust Fan(s) .....	3-7
3.3.1.5	Motors and Voltages.....	3-7
3.3.1.6	AHU Casing.....	3-7
3.3.1.7	Access Sections and Mixing Box .....	3-7
3.3.1.8	Blender Section .....	3-7
3.3.1.9	Drain Pan.....	3-7
3.3.1.10	Cooling Coils .....	3-7
3.3.1.11	Preheat Coils .....	3-8
3.3.1.12	Unit-Mounted Reheat Coils.....	3-8
3.3.1.13	Corrosion Protection .....	3-8
3.3.1.14	Filtration.....	3-8
3.3.1.15	Humidifier .....	3-9
3.4	ALL-AIR SYSTEM – TYPES.....	3-10
3.4.1	VARIABLE AIR VOLUME (VAV) SYSTEMS .....	3-10
3.4.2	CONSTANT VOLUME SYSTEMS .....	3-10
3.5	TERMINAL HEATING AND COOLING SYSTEMS .....	3-10
3.5.1	FAN COIL UNITS .....	3-11
3.5.1.1	Special Requirements.....	3-11
3.5.1.2	Fan Coil Unit Configuration.....	3-11
3.5.2	GROUND SOURCE HEAT PUMPS (GSHP) .....	3-11
3.5.2.1	General.....	3-11
3.5.2.2	References .....	3-11
3.5.2.3	Selection Parameters.....	3-12
3.5.2.4	Heating/Cooling Loads.....	3-12
3.5.2.5	Life-Cycle Cost Analysis .....	3-12
3.5.2.6	Recommendations.....	3-13
3.6	MINIMUM VENTILATION AIR-HANDLING UNITS (100% OUTDOOR AIR UNIT) .....	3-13
3.6.1	GENERAL .....	3-13
3.6.2	FILTRATION.....	3-13
3.6.3	VENTILATION AIR CONTROL.....	3-13
3.6.4	VENTILATION AIR OUTLETS .....	3-13
3.7	HEATING AND VENTILATION SYSTEMS (HVV) .....	3-13
3.7.1	GENERAL .....	3-13
3.7.2	SYSTEM CONFIGURATION .....	3-13
3.8	HEAT RECOVERY SYSTEMS .....	3-14
3.8.1	GENERAL .....	3-14
3.8.2	SENSIBLE HEAT TRANSFER.....	3-14
3.8.2.1	Run-Around System .....	3-14
3.8.2.2	Fixed Plate System (Air-to-Air).....	3-14
3.8.2.3	Heat Pipes.....	3-14
3.8.3	SENSIBLE AND LATENT HEAT TRANSFER.....	3-14
3.8.3.1	Desiccant (Enthalpy) Heat Wheels.....	3-14
3.8.3.2	Energy Savings (Impact on Equipment Selection) .....	3-14
3.8.3.3	Exceptions .....	3-15
3.9	EXHAUST SYSTEMS.....	3-15
3.9.1	GENERAL EXHAUST SYSTEM .....	3-15
3.9.1.1	System Components .....	3-15
3.9.2	SPECIAL EXHAUST SYSTEMS (DEDICATED EXHAUST SYSTEMS).....	3-15
3.9.2.1	Design Considerations.....	3-15



## Table of Contents

3.10	AIR DISTRIBUTION .....	3-16
3.10.1	MANDATORY REQUIREMENTS .....	3-16
3.10.1.1	Plenum Return System .....	3-16
3.10.1.2	Construction Drawings .....	3-16
3.10.2	DUCTWORK .....	3-16
3.10.2.1	Duct Materials .....	3-16
3.10.2.2	Flexible Ductwork .....	3-16
3.10.2.3	Minimum Duct Size .....	3-16
3.10.2.4	Duct Sizing Criteria .....	3-16
3.10.2.5	Duct Pressure Classification .....	3-17
3.10.2.6	Exposed Ductwork .....	3-17
3.10.3	AIR TERMINAL UNITS .....	3-17
3.10.3.1	General .....	3-17
3.10.3.2	Limiting Capacities .....	3-17
3.10.3.3	Air Distribution Outlets/Inlets .....	3-17
3.11	APPLICATIONS .....	3-18
3.11.1	GENERAL .....	3-18
3.11.2	AIR-HANDLING UNITS ZONING CRITERIA .....	3-18
3.11.2.1	Selecting Air-Handling Units .....	3-18
3.11.2.2	Considerations .....	3-18
3.11.2.3	Home and Community Center .....	3-18
3.11.2.4	Common Spaces .....	3-19
3.11.2.5	Enclosed Circulation Spaces .....	3-19
3.11.2.6	All Air Systems – AHU System Data Sheets .....	3-19
	ATRIUM – AIR-HANDLING UNIT .....	3-20
	AHU System Data Sheet .....	3-20
	AUDITORIUMS AND THEATERS – AIR-HANDLING UNIT .....	3-21
	AHU System Data Sheet .....	3-21
	GYMNASIUM – AIR-HANDLING UNIT .....	3-22
	AHU System Data Sheet .....	3-22
	HOME AND COMMUNITY CENTER – AIR-HANDLING UNIT .....	3-23
	AHU System Data Sheet .....	3-23
	KITCHEN (FOOD PRODUCTION) – AIR-HANDLING UNIT .....	3-24
	AHU System Data Sheet .....	3-24
	MINIMUM VENTILATION AIR – AIR-HANDLING UNIT .....	3-26
	AHU System Data Sheet .....	3-26
	STANDALONE SMOKING FACILITY – AIR-HANDLING UNIT .....	3-27
	AHU System Data Sheet .....	3-27
3.12	ROOM DATA SHEETS .....	3-28
3.12.1	GENERAL .....	3-28
3.12.2	TERMINAL HVAC SYSTEMS .....	3-28
	COMMUNITY CENTER – ROOM DATA SHEETS .....	3-29
	Bistro .....	3-29
	Chapel/Meditation .....	3-29
	Concierge Station .....	3-29
	Conference Room .....	3-29
	Copy Room .....	3-29
	Garage .....	3-29
	Great Room .....	3-30
	HAC .....	3-30
	Hair Care (Barber/Beauty) .....	3-30
	Media Center .....	3-30
	Multi-Purpose Room .....	3-30

Offices – Activities Director/Administrators/Maintenance/Nursing .....	3-30
Public Toilets .....	3-30
Satellite Telephone/Communications Closet .....	3-31
Staff Lounge and Lockers .....	3-31
Staff Toilet.....	3-31
Storage – Multi-Purpose Room/General/Maintenance .....	3-31
Vestibule.....	3-31
COMMUNITY CENTER – MISCELLANEOUS SPACES – ROOM DATA SHEETS .....	3-32
Attic Space.....	3-32
Crawl Space (Pipe Basement) .....	3-32
Electrical Equipment Rooms (EER).....	3-33
Electrical Equipment Closets without Internal Heat Gain.....	3-33
Satellite and Main Electrical Rooms with Internal Heat Gain.....	3-33
Exterior Stairs .....	3-33
Mechanical Equipment Rooms (MER) .....	3-34
Air-Handling Equipment Rooms.....	3-34
Heating Rooms.....	3-34
Refrigeration Equipment Rooms.....	3-35
COMMUNITY CENTER – OPTIONAL SPACES – ROOM DATA SHEETS.....	3-36
Examination Room.....	3-36
Pharmacy .....	3-36
Physician Office .....	3-36
Receiving/Loading .....	3-36
Security Office .....	3-36
HOME – ROOM DATA SHEETS .....	3-37
Bathing Suite .....	3-37
Bedroom – Resident .....	3-37
Bedroom – Special Care Resident.....	3-37
Clean Linen Closet.....	3-37
Corridor.....	3-38
Den.....	3-38
Dining Room .....	3-38
Foyer .....	3-38
Garage.....	3-38
HAC.....	3-38
Hair Care (Barber/Beauty) .....	3-38
Home Entry/Front Porch .....	3-39
Home Office.....	3-39
Home Storage.....	3-39
Kitchen and Pantry.....	3-39
Kitchen Housekeeping Closet .....	3-39
Laundry.....	3-39
Living Room.....	3-39
Soiled Utility Room.....	3-40
Toilet – Public .....	3-40
Toilet – Special Care Resident.....	3-40
Toilet and Showers – Resident .....	3-40
CHAPTER 4: BUILDING COOLING AND HEATING SYSTEMS .....	4-1
4.1    INTRODUCTION .....	4-2
4.2    COOLING SYSTEMS .....	4-2
4.2.1    CENTRAL CHILLED WATER PLANTS .....	4-2
4.2.2    DEDICATED CHILLED WATER SYSTEMS .....	4-2

## Table of Contents

4.2.2.1	General.....	4-2
4.2.2.2	Air-Cooled Chillers.....	4-2
4.2.2.3	Standby Capacity Requirement .....	4-2
4.2.2.4	Refrigerant.....	4-3
4.2.2.5	Physical Security Requirements .....	4-3
4.2.2.6	Chiller Performance .....	4-3
4.2.2.7	Miscellaneous Requirements.....	4-3
4.2.2.8	Chilled Water Piping/Pumping Configuration .....	4-4
4.2.2.9	Chilled Water Distribution System – Primary-Secondary System (PSS).....	4-4
4.2.2.10	Chilled Water Distribution System – Variable Primary System (VPS).....	4-4
4.2.2.11	Single Chiller Systems (Constant and Variable Volume).....	4-5
4.2.3	CHILLED WATER SYSTEM COMPONENTS.....	4-5
4.2.3.1	Pump Types .....	4-5
4.2.3.2	Pump Selection.....	4-5
4.2.3.3	Cooling Towers.....	4-6
4.2.3.4	Water Treatment – Chilled Water System.....	4-6
4.2.3.5	Water Treatment – Condenser Water System .....	4-6
4.2.3.6	Glycol – Chilled Water Systems.....	4-7
4.2.4	DIRECT EXPANSION (DX) SYSTEMS .....	4-7
4.2.4.1	Self-Contained Terminal Units .....	4-7
4.2.5	DIRECT EXPANSION (DX) VAV SYSTEMS – ROOFTOP UNITS.....	4-7
4.3	HEATING SYSTEMS.....	4-8
4.3.1	STEAM HEATING SYSTEMS.....	4-8
4.3.1.1	General.....	4-8
4.3.1.2	Standby Capacity.....	4-8
4.3.1.3	Steam System Specialties and Piping.....	4-8
4.3.2	HYDRONIC HEATING SYSTEMS.....	4-8
4.3.2.1	Boilers – General.....	4-8
4.3.2.2	Boiler Selection Criteria .....	4-9
4.3.2.3	Hot Water Piping and Pumping.....	4-9
4.3.2.4	Hot Water Terminal Units.....	4-9
4.3.2.5	Freeze Protection – Hot Water.....	4-9
4.3.3	ELECTRICAL HEATING SYSTEMS.....	4-10
4.3.3.1	General.....	4-10
4.3.3.2	Applications .....	4-10
4.3.3.3	Controls .....	4-10
4.3.4	GAS HEATING SYSTEMS .....	4-10
4.3.4.1	General.....	4-10
4.3.4.2	Applications .....	4-10
4.3.4.3	Heating Equipment .....	4-10
4.3.4.4	Miscellaneous Items .....	4-10
4.3.5	GEOHERMAL HEATING SYSTEMS.....	4-11
4.3.5.1	General.....	4-11
4.3.5.2	References .....	4-11
4.3.5.3	Analysis .....	4-11
4.4	PIPING .....	4-11
4.4.1	DESIGN CRITERIA – WATER PIPING.....	4-11
4.4.1.1	Minimum Pipe Size .....	4-11
4.4.1.2	Drains and Vents .....	4-11
4.4.1.3	Dielectric Fitting .....	4-11
4.4.1.4	Water Pipe Sizing .....	4-12
4.4.2	DESIGN CRITERIA – STEAM PIPING .....	4-12
4.4.2.1	General.....	4-12

4.4.2.2	Pressure Classification .....	4-12
4.4.2.3	Steam Pipe Sizing .....	4-12
4.4.2.4	Steam Pressure Requirements .....	4-13
4.4.2.5	Pressure Reducing Valve (PRV) Stations .....	4-13
4.4.2.6	Miscellaneous Design Requirements .....	4-13
APPENDIX 4A:	PROPYLENE GLYCOL – WATER SOLUTION .....	4A-1
4A.1	GENERAL .....	4A-1
4A.1.1	SELECTION CRITERIA.....	4A-1
4A.1.2	COIL FREEZE PROTECTION .....	4A-1
4A.1.3	PROPYLENE GLYCOL PROPERTIES.....	4A-2
4A.2	PUMP SELECTION .....	4A-3
4A.2.1	STEP 1: EQUIPMENT FLOW RATE AND HEAD .....	4A-3
4A.2.2	STEP 2: HEAD CORRECTION DUE TO VISCOSITY.....	4A-3
4A.2.3	STEP 3: POWER CORRECTION DUE TO VISCOSITY .....	4A-3
4A.2.4	SAMPLE PUMP SELECTION – WITH PROPYLENE GLYCOL SOLUTION .....	4A-4
4A.3	NOTES TO BE ADDED TO EQUIPMENT SCHEDULES.....	4A-6
CHAPTER 5:	AUTOMATIC TEMPERATURE CONTROLS.....	5-1
5.1	GENERAL .....	5-2
5.2	BASIC DESIGN .....	5-2
5.2.1	NEW STANDALONE FACILITY.....	5-2
5.2.2	NEW FACILITY OR RENOVATION .....	5-2
5.3	DETAILED DESIGN .....	5-2
5.3.1	OPTION DESCRIPTIONS .....	5-2
5.3.1.1	Option 1.....	5-2
5.3.1.2	Option 2.....	5-3
5.3.1.3	Option 3.....	5-3
5.3.1.4	Option 4.....	5-3
5.3.1.5	Option 5.....	5-3
5.4	BACNET CONTROLLER IDENTIFICATION.....	5-3
5.5	SPECIFIC REQUIREMENTS.....	5-3
5.5.1	CONTROL ACTUATORS .....	5-3
5.5.2	CONTROL VALVES .....	5-3
5.5.3	CONTROL DAMPERS.....	5-3
5.5.4	END-SWITCHES .....	5-3
5.5.5	SAFETIES .....	5-4
5.5.6	CONTROL WIRING.....	5-4
5.5.7	PERSONAL COMPUTER (PC).....	5-4
5.5.8	LAPTOP COMPUTER .....	5-4
5.5.9	SOFTWARE .....	5-4
5.5.10	COLOR GRAPHICS .....	5-4
5.5.11	SPREADSHEETS.....	5-4
5.5.12	SECURITY .....	5-4
5.5.13	STATUS MONITORING .....	5-4
5.5.14	ROOM TEMPERATURE SENSORS .....	5-4
5.5.15	HUMIDITY SENSORS.....	5-5
5.5.16	METERING REQUIREMENTS .....	5-5
5.6	SYSTEM APPLICATIONS .....	5-5
5.6.1	GENERAL .....	5-5
5.6.2	AIRSIDE CONTROLS.....	5-5
5.6.2.1	Air-Handling Units.....	5-5
5.6.2.2	Individual Room Temperature Control .....	5-6
5.6.3	HEATING SYSTEM CONTROLS .....	5-6

## Table of Contents

5.6.4	CHILLED WATER SYSTEM CONTROLS.....	5-7
5.6.5	NON-DDC CONTROLS.....	5-7
5.7	DOCUMENTATION REQUIREMENTS.....	5-8
5.7.1	SCHEMATIC DIAGRAM AND CONTROL SEQUENCE.....	5-8
5.7.2	POINT LIST.....	5-8
CHAPTER 6: CLIMATIC DATA.....		6-1
Table 6-1 CLIMATIC CONDITIONS.....		6-2
Table 6-2 HIGH HUMIDITY LOCATIONS.....		6-17
Table 6-3 LOW HUMIDITY LOCATIONS.....		6-18



CHAPTER 1: BASIC REQUIREMENTS

Table of Contents

1.1	INTRODUCTION .....	1-2
1.2	COMMUNITY LIVING CENTER (CLC) .....	1-2
1.2.1	GENERAL .....	1-2
1.2.2	HOME .....	1-2
1.2.3	COMMUNITY CENTER .....	1-2
1.2.4	COMMUNITY CENTER – OPTIONAL SPACES .....	1-2
1.2.5	COMMUNITY CENTER – MISCELLANEOUS SPACES .....	1-2
1.3	DOMICILIARY (DOM) .....	1-2
1.4	COMPLIANCE .....	1-3
1.5	ENERGY CONSERVATION .....	1-3
1.5.1	ASHRAE STANDARD 90.1 – 2007 .....	1-3
1.6	MANDATED ENERGY CONSERVATION MEASURES .....	1-3
1.6.1	LIFE-CYCLE COST ANALYSIS – REQUIREMENTS .....	1-4
1.6.2	LIFE-CYCLE COST ANALYSIS – METHODOLOGY .....	1-4
1.6.3	ENERGY REDUCTION REQUIREMENT – NEW CONSTRUCTION .....	1-4
1.6.4	ENERGY REDUCTION REQUIREMENT – MAJOR RENOVATIONS .....	1-4
1.7	MEASUREMENT AND VERIFICATION .....	1-4
1.8	APPLICABLE CODES AND STANDARDS .....	1-5
1.9	COMMISSIONING .....	1-5
1.10	VA STANDARDS .....	1-5
1.10.1	DESIGN MANUALS (by discipline) (PG-18-10) .....	1-5
1.10.2	MINIMUM REQUIREMENTS FOR A/E SUBMISSIONS (PG-18-15) .....	1-6
1.10.3	MASTER CONSTRUCTION SPECIFICATIONS (PG-18-1) .....	1-6
1.10.4	ARCHITECT/ENGINEER REVIEW CHECKLIST .....	1-6
1.10.5	DESIGN ALERTS .....	1-7
1.10.6	A/E QUALITY ALERTS .....	1-7
1.10.7	DESIGN GUIDES (graphical, by function) (PG-18-12) .....	1-7
1.10.8	DESIGN AND CONSTRUCTION PROCEDURES (PG-18-3) .....	1-7
1.10.9	STANDARD DETAILS AND CAD STANDARDS (PG-18-4) .....	1-8
1.10.10	PHYSICAL SECURITY DESIGN MANUAL FOR VA FACILITIES – MISSION CRITICAL FACILITIES AND LIFE SAFETY PROTECTED FACILITIES (FORMERLY CD-54) .....	1-8
1.10.11	COST ESTIMATING MANUAL .....	1-8
1.10.12	SUSTAINABLE DESIGN AND ENERGY REDUCTION MANUAL .....	1-8
1.10.13	SEISMIC DESIGN REQUIREMENTS (STRUCTURAL) (H-18-18) .....	1-9
1.10.14	FIRE PROTECTION DESIGN MANUAL .....	1-9
1.11	BUILDING INFORMATION MODEL (BIM) GUIDE .....	1-9
1.12	COMPUTER AIDED FACILITIES MANAGEMENT (CAFM) .....	1-9
1.12.1	CAFM AND EQUIPMENT SCHEDULE UTILIZATION .....	1-9
1.13	HVAC DESIGN MANUAL AND A/E SUBMISSION REQUIREMENTS (PG-18-15) .....	1-9
1.13.1	COORDINATION .....	1-9
1.13.2	COMPLIANCE REQUIREMENTS .....	1-10
1.13.3	EQUIPMENT SCHEDULES .....	1-10
1.13.3.1	Order of Presentation .....	1-10
1.13.3.2	Equipment Capacity and Performance Data Requirements .....	1-10
1.13.3.3	Equipment Schedules – Glycol Data .....	1-10

## **1.1 INTRODUCTION**

This manual includes design criteria for Heating, Ventilation, and Air-Conditioning (HVAC) systems of Community Living Centers (CLC), Domiciliaries (DOM), and their associated support functions. Community Living Center and Domiciliary facilities are considered Mission Critical Facilities according to the VA Physical Security Design Manual.

The HVAC system design shall vary with, and adapt to, the configurations of the facilities. VA has embraced a novel concept of housing veterans in a more homelike environment, using a community concept.

## **1.2 COMMUNITY LIVING CENTER (CLC)**

### **1.2.1 GENERAL**

The Nursing Home Care Unit (NHCU) is replaced by the Community Living Center (CLC). The CLC architectural space configuration is generally designed to reflect a residential care environment. Although the CLC is classified as healthcare occupancy, it essentially functions as a Skilled Nursing Facility (SNF) and a Hospice, housing veterans with healthcare-related issues including:

- Chronic but stable conditions
- Short-term rehabilitation
- Need for short-term specialized services
- Need for comfort and care at the end of their lives

The CLC facility design comprises four essential components: Home, Community Center, and Community Center Miscellaneous and Optional spaces.

### **1.2.2 HOME**

Home, also known as Residential Home (formerly Nursing Unit), is a cluster of single-occupancy rooms and supporting areas, i.e., Resident Bedroom, Kitchen Housekeeping Closet, and Foyer. Generally, a cluster will comprise eight to ten rooms. The room HVAC system design shall be similar to patient rooms in a hospital nursing wing, providing individual room temperature control, minimum outdoor air, and continuous exhaust through the bathroom.

### **1.2.3 COMMUNITY CENTER**

A group of approximately three homes is served by a Community Center comprising common spaces, such as Great Room, Media Center, and Offices. The HVAC system serving these spaces may be disabled during unoccupied hours.

### **1.2.4 COMMUNITY CENTER – OPTIONAL SPACES**

Common spaces serving the entire CLC complex are spaces such as Examination Room, Pharmacy, and Security Office. The HVAC system serving these spaces may be disabled during unoccupied hours.

### **1.2.5 COMMUNITY CENTER – MISCELLANEOUS SPACES**

Miscellaneous spaces serving the CLC are spaces such as Attic space and Electrical and Mechanical Rooms. These spaces shall be provided with heating and ventilation, but may not require mechanical cooling.

## **1.3 DOMICILIARY (DOM)**

Domiciliary differs from the CLC as the occupants do not require clinical intervention or bedside nursing intervention and are capable of daily self-care. However, the occupants do require a full range of



Rehabilitation Services, including Post-Traumatic Stress Disorder Therapy. The occupants may be classified as homeless, unemployed, or suffering from psychological or social problems. Domiciliary is classified as residential or institutional occupancy. The HVAC systems shall be similar to the CLC facility.

### 1.4 COMPLIANCE

The HVAC system design shall be in compliance with the following documents:

- VA Physical Security Manuals (Mission Critical)
- VA Sustainable Design and Energy Reduction Manual
- VA Commissioning Process Manual
- Third Party Certification – LEED (Silver) or Green Globes (Two Globes)
- BIM Guide
- Measurement and Verification
- Applicable Codes and Standards (shown below)

This manual is intended for the Architect/Engineer (henceforth referred to as the A/E) and others engaged in the design and renovation of VA facilities. VA Medical Centers are encouraged to use these criteria for Non Recurring Maintenance (NRM) and Minor Construction Projects (MCP) to ensure systemic quality control and uniformity in design and construction practices and procedures.

Use of this manual shall result in meeting the primary objective of providing environmental comfort to veterans, employees, and visitors. The HVAC system shall be:

- Technically correct, complete, and coordinated
- In compliance with all applicable safety standards
- Easily accessible for repairs and maintenance
- Energy-efficient
- In compliance with prescribed noise and vibration levels

Deviations from this manual may be proposed to promote new concepts and design enhancements. Deviations shall not conflict with any federal regulations, public laws, executive orders, or the needs of the end-users. Any deviations are subject to review and approval by the VA Project Manager in consultation with the VA Facilities Consulting Support service. For projects designed and contracted by the Office of Construction and Facilities Management, the VA Project Manager is the VA Authority. Interfacing with the VA Medical Center shall be through the VA Project Manager.

### 1.5 ENERGY CONSERVATION

Refer to the VA Sustainable Design and Energy Reduction Manual .

#### 1.5.1 ASHRAE STANDARD 90.1 – 2007

ASHRAE Standard 90.1 – 2007 is a component of the federal statutes. Provisions of this standard shall be used as a baseline for computing energy savings.

### 1.6 MANDATED ENERGY CONSERVATION MEASURES

The Department of Energy (DOE) has mandated that new federal buildings shall be designed to achieve an energy consumption level at least 30% below that attained by the ASHRAE Standard 90.1 – 2007 baseline building, if life-cycle cost-effective. Use the Performance Rating Method, Appendix G of ASHRAE Standard 90.1 – 2002, to document energy savings.

### **1.6.1 LIFE-CYCLE COST ANALYSIS – REQUIREMENTS**

If 30% reduction in energy consumption is not life-cycle cost-effective, the A/E shall evaluate alternate designs at successive decrements (for example, 25%, 20%, or lower) in order to identify the most energy-efficient design that is life-cycle cost-effective. The A/E shall consider and evaluate readily available energy conservation measures with which the industry is generally familiar, then determine the most energy-efficient solution by using a life-cycle cost analysis approach. Refer to VA Sustainable Design and Energy Reduction Manual.

The DOE further stipulates that “agencies must estimate the life-cycle costs and energy consumption of the planned building as designed and an otherwise identical building just meeting the minimum criteria set forth in the applicable baseline ASHRAE or IECC standard.” This measure is meant to demonstrate and record the extent to which mandated compliance is achieved.

### **1.6.2 LIFE-CYCLE COST ANALYSIS – METHODOLOGY**

An engineering and economic analysis shall be performed in accordance with the procedure outlined by the DOE in the National Institute of Standards and Technology (NIST) Handbook 135 dated February 1996 (or the latest version) – Life-Cycle Costing Manual for the Federal Energy Management Program.

Use the following parameters when performing the analysis:

- Life-cycle study period: expected system life not to exceed 40 years
- Building Life-Cycle Cost (BLCC) computational program (located on the NIST website)
- Discount factor as determined by DOE on Oct 1 of each year
- Include initial acquisition costs such as planning, design, purchase and construction, and capital replacement costs. Include operating costs, such as energy used, water used, and operating, maintenance, and repair costs. Taxes and insurance need not be included in the life-cycle cost analysis

### **1.6.3 ENERGY REDUCTION REQUIREMENT – NEW CONSTRUCTION**

Reduce the energy cost budget by 30% compared to the baseline performance rating of ASHRAE Standard 90.1 – 2007. This requirement is identical to the DOE Final Rule published in the Federal Register.

### **1.6.4 ENERGY REDUCTION REQUIREMENT – MAJOR RENOVATIONS**

Reduce the energy cost budget by 20% below the pre-renovation 2003 baseline. If pre-renovation 2003 baseline data is not available, the A/E shall calculate the energy consumption before renovation, compare it with the energy consumption after renovation, and document the mandated savings. A project classified as “major renovation” shall meet the following two criteria:

- (a) For a facility selected for renovation, the area of renovation is greater than 50% of the total area.
- (b) A project is planned that significantly extends the building’s useful life through alterations or repairs and totals more than 30% of the replacement value of the facility.

## **1.7 MEASUREMENT AND VERIFICATION**

Per DOE Guidelines issued under Section 103 of EPACKT, install building-level utility meters in new major construction and renovation projects to track and continuously optimize performance. Memorandum of Understanding (MOU) mandates that the actual performance data from the first year of operation shall be compared with the energy design target. After one year of occupancy, the A/E shall measure all new major installations using the ENERGY STAR® Benchmarking Tool for building

and space types covered by ENERGY STAR® or FEMP-designated equipment. The A/E shall submit a report of findings to the VA Authorities.

**1.8 APPLICABLE CODES AND STANDARDS**

Applicable codes and standards are listed below. These references are also given in the text, where applicable.

ABBREVIATION	DESCRIPTION
AMCA	Air Movement and Control Association International
ANSI	American National Standards Institute
AHRI	Air-Conditioning Heating and Refrigeration Institute
ASCE	American Society of Civil Engineers
ASHRAE	American Society of Heating, Refrigerating and Air-Conditioning Engineers
DOE	Department of Energy
FEMP	Federal Energy Management Program
IMC	International Mechanical Code
IBC	International Building Code
IPC	International Plumbing Code
ISO	International Organization for Standardization
NEC	National Electric Code
NEMA	National Electrical Manufacturers Association
NFPA	National Fire Protection Association
NSF	National Sanitation Foundation International
OSHA	Operational Safety and Health Administration
SMACNA	Sheet Metal and Air-Conditioning Contractors' National Association
UBC	Uniform Building Code
UL	Underwriters Laboratories

**1.9 COMMISSIONING**

The scope of work shall include Total Building Commissioning in accordance with the Commissioning Process Manual scheduled to be published in 2011.

**1.10 VA STANDARDS**

The A/E shall download applicable documents from the Technical Information Library (TIL) and submit a list of these documents with their effective dates to VA Authorities.

Descriptions of major standards follow:

**1.10.1 DESIGN MANUALS (by discipline) (PG-18-10)**

Located in the Technical Information Library (TIL)  
<http://www.cfm.va.gov/TIL/dManual.asp>

**Purpose**

Conveys the general and specific VA design philosophy for medical and support facilities. The manuals accomplish this by:

- Explaining specific design methodologies
- Listing acceptable system types
- Codifying certain code interpretations
- Listing values for design parameters

- Referencing certain sections of the Master Specification and Standard Details
- Containing examples of certain design elements

### **1.10.2 MINIMUM REQUIREMENTS FOR A/E SUBMISSIONS (PG-18-15)**

Located in Architect/Engineer Information

<http://www.cfm.va.gov/contract/aeDesSubReq.asp>

The submission requirements shall be implemented in conjunction with Appendix 1-A.

#### **Purpose**

Provides a staged list of tasks in various design categories to define the A/E scope and ensure thorough and timely completion of the final design package and bid documents.

The requirements accomplish this by:

- Progressively listing tasks at Schematic, Design Development, and Construction Documents stages
- Requiring task completion and submission for each stage according to a Critical Path Method (CPM) calendar
- Requiring implementation of a QA/QC process to ensure a quality design product
- Requiring life-cycle analysis of alternatives in order to optimize the design-to-cost tradeoff
- Listing and detailing all the drawings, calculations, and specifications required for a complete design package
- Indicating the final distribution of bid documents
- Indicating the interface between this Design Manual and Submission Requirements at each submission phase

**Note:** The A/E shall include with the Construction Documents (CD1) submittal, an electronic version of the VA Master Specifications, with tracked changes or modifications displayed.

### **1.10.3 MASTER CONSTRUCTION SPECIFICATIONS (PG-18-1)**

Located in the Technical Information Library (TIL)

<http://www.cfm.va.gov/TIL/spec.asp>

#### **Purpose**

Defines a standardized method for the A/E to ensure that the contractors provide equipment and systems that meet the design intent in terms of performance, quality, and cost.

The specifications accomplish this by:

- Providing specific narrative descriptions of required equipment, salient elements, and system construction
- Listing applicable standards and codes and references
- Requiring individual submittal of equipment and systems for review and approval prior to contractor purchase
- Defining specific installation methods to be used

### **1.10.4 ARCHITECT/ENGINEER REVIEW CHECKLIST**

Located in the Technical Information Library (TIL)

<http://www.cfm.va.gov/til/projReq.asp>

#### **Purpose**

Provides the VA Peer Reviewer with a minimum list of critical items which must be included in each A/E submission.

The checklist accomplishes this by:

- Referring to all VA design tools which pertain to the specific project
- Detailing certain life safety and coordination requirements

### **1.10.5 DESIGN ALERTS**

Located in the Technical Information Library (TIL)

<http://www.cfm.va.gov/TIL/alertDesign.asp>

#### **Purpose**

Communicates current design issues and solutions.

The design alerts accomplish this by:

- Publishing periodic alert memos
- Summarizing design solutions

### **1.10.6 A/E QUALITY ALERTS**

Located in the Technical Information Library (TIL)

<http://www.cfm.va.gov/TIL/alert.asp#qalert>

#### **Purpose**

Communicates quality deficiencies from recent A/E design submissions.

The quality alerts accomplish this by:

- Publishing checklists of design details often missed
- Including references to technical resources

### **1.10.7 DESIGN GUIDES (graphical, by function) (PG-18-12)**

Located in the Technical Information Library (TIL)

<http://www.cfm.va.gov/TIL/dGuide.asp>

#### **Purpose**

Provides the designer with specific layout templates and medical equipment lists for all types of spaces/uses and specific design parameters for structural, electrical, and mechanical service.

The design guides accomplish this by:

- Publishing design information
- Including functional diagrams and layout plates
- Listing standards

### **1.10.8 DESIGN AND CONSTRUCTION PROCEDURES (PG-18-3)**

Located in the Technical Information Library (TIL)

<http://www.cfm.va.gov/TIL/cPro.asp>

#### **Purpose**

Establishes minimum consistent design/construction practices.

The procedures section accomplishes this by:

- Referencing applicable codes and policies
- Describing standard drawing formats
- Listing security strategies
- Including miscellaneous design details

### **1.10.9 STANDARD DETAILS AND CAD STANDARDS (PG-18-4)**

Located in the Technical Information Library (TIL)

<http://www.cfm.va.gov/TIL/sDetail.asp>

#### **Purpose**

Promotes standardization of CAD documents submitted to VA Authorities.

The standards section accomplishes this by:

- Providing downloadable equipment schedules
- Listing symbols and abbreviations
- Providing downloadable standard details in .dwg or .dwt format
- Providing requirements for preparing CAD drawings

**Note:** The A/E shall utilize the VA Standard Details to the fullest extent possible. A modification to a Standard Detail requires the approval of VA Authorities. A comprehensive list of symbols and abbreviations is included with the VA Standard Details. Use of the VA abbreviation list is mandatory. Edit the VA list to be project-specific.

All mechanical drawings shall be numbered and arranged in strict accordance with VA CAD Standards.

### **1.10.10 PHYSICAL SECURITY DESIGN MANUAL FOR VA FACILITIES – MISSION CRITICAL FACILITIES AND LIFE SAFETY PROTECTED FACILITIES (FORMERLY CD-54)**

Located in the Technical Information Library (TIL)

<http://www.cfm.va.gov/til/spclRgmts.asp#PHS>

#### **Purpose**

Sets physical security standards required for facilities to continue operation during a natural or man-made extreme event and for facilities that are required to protect the life safety of patients and staff in an emergency.

The manuals accomplish this by:

- Setting objectives for physical security
- Providing strategies for use in design and construction to provide protection to VA facilities
- Providing cost-effective design criteria

### **1.10.11 COST ESTIMATING MANUAL**

Located in Cost Estimating

<http://www.cfm.va.gov/cost/>

#### **Purpose**

Conveys the general and specific VA cost estimating philosophy for medical facilities.

The manual accomplishes this by:

- Explaining specific estimating methodologies
- Providing examples of certain design elements

### **1.10.12 SUSTAINABLE DESIGN AND ENERGY REDUCTION MANUAL**

Located in the Technical Information Library (TIL)

<http://www.cfm.va.gov/til/sustain.asp>

#### **Purpose**

Incorporates sustainable design practices to improve the building environment and to provide cost savings for long-term building operations and maintenance.

The manual accomplishes this by:

- Prescribing the use of integrated design practices
- Providing strategies for optimization of energy performance
- Providing strategies for protection and conservation of water resources
- Providing strategies for enhancement of indoor environmental quality
- Providing strategies for reduction of environmental impact of materials

### **1.10.13 SEISMIC DESIGN REQUIREMENTS (STRUCTURAL) (H-18-18)**

Located in the Technical Information Library (TIL)

<http://www.va.gov/TIL/seismic.asp>

#### **Purpose**

Sets the requirements for seismic design in new facilities and for rehabilitation of existing facilities.

The manual accomplishes this by:

- Defining critical and essential facilities
- Prescribing code compliance with modifications
- Prescribing occupancy categories

### **1.10.14 FIRE PROTECTION DESIGN MANUAL**

Located in the Technical Information Library (TIL)

<http://www.cfm.va.gov/TIL/dManual.asp#Other>

#### **Purpose**

Provides the fire protection engineering design criteria for all categories of VA construction and renovation projects.

The manual accomplishes this by:

- Mandating code and standard compliance
- Defining water-supply requirements
- Defining fire extinguishing and fire alarm system requirements

### **1.11 BUILDING INFORMATION MODEL (BIM) GUIDE**

Located in the Technical Information Library (TIL)

<http://www.cfm.va.gov/til/projReq.asp>

VA has implemented the BIM system for all major construction and renovation projects per details given in the VA BIM Guide.

### **1.12 COMPUTER AIDED FACILITIES MANAGEMENT (CAFM)**

#### **1.12.1 CAFM AND EQUIPMENT SCHEDULE UTILIZATION**

The requirement for access to a master digital database necessitates the compilation of all architectural/engineering design data (plans, specifications, calculations, equipment selections, equipment submittal, commissioning/balance reports, and both hard copy and electronic job-related communications) in a digital, electronic format throughout the project. This need for digital data will affect the requirements for submission (see Design Submission Requirements).

### **1.13 HVAC DESIGN MANUAL AND A/E SUBMISSION REQUIREMENTS (PG-18-15)**

#### **1.13.1 COORDINATION**

The documentation requirements outlined in PG-18-15 are the minimum contractual milestones and not the details and procedures described in this manual. By supplementing each other, these two

documents provide comprehensive guidelines to develop backup documentation for successful and state-of-the-art design.

### **1.13.2 COMPLIANCE REQUIREMENTS**

For each submittal, the A/E shall forward to VA a detailed list of the submissions required with a notation of full or partial compliance.

### **1.13.3 EQUIPMENT SCHEDULES**

#### **1.13.3.1 Order of Presentation**

For each item in a schedule, show the Basis of Design, including the manufacturer and model number selected. These columns shall be hidden on the final design documents but available for VA use and for use later in the design/construction and maintenance process.

Equipment schedules shall be grouped on the design documents by system type, such as airside, waterside, and steam.

#### **1.13.3.2 Equipment Capacity and Performance Data Requirements**

Equipment performance and capacity data shall correspond to that shown in the calculations, not a particular manufacturer's catalog data. The data shall be in the range of available manufactured products.

#### **1.13.3.3 Equipment Schedules – Glycol Data**

Heat exchangers, coils, pumps, and chillers in glycol-water system shall be identified on the equipment schedule showing the percent glycol by volume of the circulating fluid for equipment derating purposes.



## CHAPTER 2: HVAC DESIGN PARAMETERS AND SELECTION CRITERIA

### CHAPTER 2: HVAC DESIGN PARAMETERS AND SELECTION CRITERIA

#### Table of Contents

2.1	INTRODUCTION .....	2-3
2.2	BASIS OF DESIGN .....	2-3
2.2.1	OUTDOOR DESIGN CONDITIONS.....	2-3
2.2.1.1	Cooling and Heating Load Calculations .....	2-3
2.2.1.2	Cooling Tower Selection .....	2-3
2.2.1.3	Preheat Coil Selection .....	2-3
2.2.1.4	Electrical Heating Devices Using Emergency Power .....	2-3
2.2.2	INDOOR DESIGN CONDITIONS .....	2-3
2.2.2.1	General.....	2-3
2.2.2.2	Indoor Space Temperature .....	2-3
2.2.2.3	Indoor Space Relative Humidity – Dehumidification .....	2-4
2.2.2.4	Indoor Space Relative Humidity – Humidification.....	2-4
2.2.3	ROOM AIR BALANCE .....	2-4
2.2.3.1	General.....	2-4
2.2.3.2	Neutral (o) Air Balance.....	2-4
2.2.3.3	Negative (-) Air Balance.....	2-5
2.2.3.4	Double Negative (- -) Air Balance .....	2-5
2.2.3.5	Positive (+) Air Balance .....	2-5
2.2.3.6	Double Positive (+ +) Air Balance .....	2-5
2.2.4	OCCUPANCY.....	2-5
2.2.5	LIGHT AND POWER LOAD.....	2-5
2.2.6	BUILDING THERMAL ENVELOPE.....	2-5
2.2.7	OUTDOOR AIR FOR VENTILATION (CALCULATION REQUIREMENTS) .....	2-5
2.3	COOLING AND HEATING LOAD CALCULATIONS .....	2-6
2.3.1	ROOM DATA OUTPUT .....	2-6
2.3.2	AHU DATA OUTPUT.....	2-6
2.3.2.1	AHU Peak Cooling Load.....	2-6
2.3.2.2	AHU Peak Supply Air Volume.....	2-6
2.3.2.3	AHU Supply Air Volume and Duct Leakage Factor .....	2-6
2.3.2.4	Psychrometric Analysis.....	2-7
2.3.3	BUILDING PEAK COOLING LOAD .....	2-7
2.4	ROOM TEMPERATURE CONTROLS.....	2-7
2.4.1	DEFINITION .....	2-7
2.4.1.1	Individually Controlled Rooms.....	2-7
2.4.1.2	Group Temperature Control – Perimeter Offices.....	2-7
2.4.1.3	Group Temperature Control – Interior Offices .....	2-7
2.4.1.4	Open Spaces.....	2-7
2.4.2	PERIMETER HEATING REQUIREMENTS.....	2-8
2.4.2.1	General.....	2-8
2.4.2.2	Perimeter Heating System Description .....	2-8
2.4.2.3	Heating Medium.....	2-8
2.4.2.4	System Sizing and Control Criteria .....	2-8
2.5	SPECIAL STUDIES REQUIREMENTS.....	2-8
2.5.1	ACOUSTIC ANALYSIS.....	2-8
2.5.1.1	General.....	2-8
2.5.1.2	Acoustic Mitigation Measures (HVAC Systems – Without Cooling Tower) .....	2-9
2.5.1.3	Acoustic Mitigation Measures (HVAC Systems – With Cooling Towers) .....	2-9
2.5.1.4	Unitary Equipment .....	2-9
2.5.2	DISPERSION ANALYSIS .....	2-10
2.5.2.1	General.....	2-10

2.5.2.2	Scope of Work .....	2-10
2.5.3	BUILDING THERMAL ENVELOPE (EXISTING FACILITIES ONLY).....	2-10
2.6	VIBRATION CONTROL .....	2-10
2.7	SEISMIC REQUIREMENTS (HVAC) .....	2-10
2.7.1	COMPLIANCE .....	2-10
2.7.2	APPLICATIONS.....	2-10
2.7.2.1	New Buildings.....	2-10
2.7.2.2	Existing Buildings.....	2-10
2.7.2.3	New and Existing Buildings – Piping .....	2-11
2.7.2.4	Local Codes.....	2-11
2.7.2.5	Omissions.....	2-11
2.7.3	CONFORMANCE WITH SMACNA .....	2-11
2.7.4	CALCULATIONS .....	2-11
2.7.5	DRAWINGS.....	2-11
2.7.5.1	General.....	2-11
2.7.5.2	Ductwork and Piping Plans and Sections.....	2-11
2.7.5.3	Equipment Restraints.....	2-11
2.8	FIRE AND SMOKE PROTECTION .....	2-11
2.8.1	COMPLIANCE .....	2-11
2.8.2	ADDITIONAL REQUIREMENTS.....	2-12
2.8.2.1	Smoke Dampers .....	2-12
2.8.3	STAIR PRESSURIZATION.....	2-12
2.8.4	ENGINEERED SMOKE CONTROL SYSTEM .....	2-12
2.8.5	ATRIUM SMOKE CONTROL.....	2-12
2.8.6	ELEVATOR SHAFT VENTING .....	2-12
2.8.6.1	Compliance.....	2-12
2.8.6.2	Hardware .....	2-12
2.9	DESIGN CONSIDERATIONS FOR EXISTING BUILDINGS .....	2-12
2.9.1	SITE SURVEY .....	2-12
2.9.1.1	As-Built Drawings .....	2-12
2.9.1.2	Site Visits.....	2-13
2.9.2	MODIFICATIONS – EXISTING SYSTEMS .....	2-13
2.9.2.1	Steam Radiators .....	2-13
2.9.2.2	DDC Controls .....	2-13
2.9.2.3	Existing Ductwork .....	2-13
2.9.2.4	Refrigerant Removal.....	2-13
2.10	PROJECT PLANNING.....	2-13
2.10.1	PHASING .....	2-13
2.10.2	UTILITY CONNECTIONS AND OUTAGES .....	2-13
2.11	TECHNICAL CONSIDERATIONS.....	2-14
2.11.1	DEMOLITION WORK .....	2-14
2.12	LOCATIONS OF OUTDOOR AIR INTAKES AND EXHAUST AIR OUTLETS.....	2-14
2.12.1	COMPLIANCE – PHYSICAL SECURITY.....	2-14
2.12.2	GENERAL .....	2-14
2.12.3	COMMON OUTDOOR AIR INTAKE .....	2-14
2.13	BID PACKAGE COORDINATION.....	2-14

## CHAPTER 2: HVAC DESIGN PARAMETERS AND SELECTION CRITERIA

### 2.1 INTRODUCTION

This chapter describes the HVAC basis of design and special studies requirements for Community Living Centers (CLC), Domiciliary (DOM) and associated support functions, collectively referred to as the Facilities. Information given below shall be used in conjunction with the VA Standard Details, Master Specifications, and associated documents, described in [Chapter 1](#) and located in the TIL.

Modern Domiciliary and Community Living Centers are constructed in a variety of sizes, shapes, and configurations, such as cluster of residences, low-rise apartments, high-rise buildings, etc. Selection of the HVAC systems shall be based on the facility configurations and the system effectiveness proven by life-cycle cost (LCC) analysis. The special requirements outlined in each chapter shall govern the system design.

### 2.2 BASIS OF DESIGN

#### 2.2.1 OUTDOOR DESIGN CONDITIONS

Weather conditions for VA facilities are given in [Chapter 6](#). These conditions are based on the locations closest to the VA facilities and given in the 2009 ASHRAE Handbook of Fundamentals. The A/E may recommend and use (subject to prior approval of the VA Authorities) more severe conditions, based on experience and knowledge of local weather conditions.

- High Humidity Locations: As defined and listed in [Chapter 6](#).
- Low Humidity Locations: As defined and listed in [Chapter 6](#).
- Hurricane Locations: Physical Security Manual

##### 2.2.1.1 Cooling and Heating Load Calculations

Use the following conditions for calculating the cooling and heating loads:

- Cooling – 0.4% Dry-Bulb and Wet-Bulb Temperatures (Column 1a)
- Heating – 99.6% Dry-Bulb Temperature (Column 1b)

##### 2.2.1.2 Cooling Tower Selection

1 F [0.6 C] above 0.4% Wet-Bulb Temperatures – Column 3

##### 2.2.1.3 Preheat Coil Selection

Annual Extreme Daily Mean Dry-Bulb Temperatures – Minimum Column

##### 2.2.1.4 Electrical Heating Devices Using Emergency Power

99.6% Dry-Bulb Temperatures – Column 1b

### 2.2.2 INDOOR DESIGN CONDITIONS

#### 2.2.2.1 General

For most spaces, the commonly specified indoor design conditions are 70 F [21 C] and 75 F [24 C] with 30 to 60% relative humidity, as shown in ASHRAE Standard 170-2008. In [Chapter 3](#), all indoor design conditions are listed in the Room Data Sheets and/or AHU System Data Sheets. Because ASHRAE Standard 170 requires that the systems be “capable of maintaining the rooms within the range during normal operation,” VA has opted to use the following indoor design conditions:

##### 2.2.2.2 Indoor Space Temperature

(a) Indoor Space Temperature – Cooling  
75 F +/- 1 F [24 C +/- 0.6 C]

**(b) Indoor Space Temperature – Heating**  
70 F +/- 1 F [21 C +/- 0.6 C]

**(c) Variable Air Volume (VAV)**

For VAV applications listed in ASHRAE Standard 90.1 – 2007, a mandated dead-band of 5 F [3 C] shall be included in the room temperature control sequence. Within the dead-band, the supply of heating and cooling energy to the zone is shut off or reduced to a minimum. The dead-band is not applicable to the resident bedrooms.

**(d) Constant Air Volume (CV)**

For CV applications, because there is no dead-band, the reheat shall be activated when the room temperature drops below 70 F [21 C].

### **2.2.2.3 Indoor Space Relative Humidity – Dehumidification**

**(a)** Maximum space relative humidity level is 60% RH.

**(b)** The space relative humidity is not directly controlled but maintained around the selected set point of 50% RH (listed as MAX RH in the Room Data Sheets in [Chapter 3](#)) by controlling the supply air temperature. Since the temperature sensor is generally located on the downstream side of the supply air fan, fan motor heat gain shall be accounted for while establishing the supply air temperature.

**(c)** If the space relative humidity exceeds 60% RH, an alarm shall be transmitted at the ECC and project-specific corrective actions shall be initiated.

### **2.2.2.4 Indoor Space Relative Humidity – Humidification**

**(a)** Minimum space relative humidity level is 30% +/- 2.5% RH (controlled).

**(b)** The indoor space relative humidity is listed as MIN RH in the Room Data Sheets in [Chapter 3](#). The space relative humidity is controlled at the set point by modulating the control valve of the steam humidifier. The relative humidity sensor is generally located in the main return or exhaust air duct. Relative humidity is controlled at the air-handling unit (zone) level. Individual room humidity control is not required.

**(c)** The relative humidity is uncontrolled between 30% and 60%.

## **2.2.3 ROOM AIR BALANCE**

### **2.2.3.1 General**

**(a)** Maintain the specified volumetric air balance between the supply and exhaust or return air as stipulated in the Room Data Sheets. Locate the supply air outlets and return/exhaust air inlets to create the directional airflow required to maintain the intended air balance. Provide devices such as an airflow control valve to measure and verify the design air balance.

**(b)** Positive or negative air balance is also required to create a differential in space pressure. Where pressure measurement and control are required, use a pressure differential sensor and matching control devices.

### **2.2.3.2 Neutral (o) Air Balance**

Supply Air = [Exhaust Air] or [Return Air] or [Exhaust Air + Return Air]

**2.2.3.3 Negative (-) Air Balance**

Exhaust Air or Return Air = [Supply Air + 15%]

**2.2.3.4 Double Negative (- -) Air Balance**

Exhaust Air or Return Air = [Supply Air + 30%]

Some applications may not require supply air to maintain double negative air balance. The intended air balance is maintained by 100% make-up air, transferred by door undercuts and transfer grilles.

**2.2.3.5 Positive (+) Air Balance**

Exhaust Air or Return Air = [Supply Air – 15%]

**2.2.3.6 Double Positive (+ +) Air Balance**

Exhaust Air or Return Air = [Supply Air – 30%]

**2.2.4 OCCUPANCY**

Select design occupancy from the following:

- (a) Applicable VA Design Guides
- (b) Project Program Data
- (c) Furniture Layout – Architectural Drawings
- (d) ASHRAE Standard 62.1 – 2007 (Ventilation for Acceptable Indoor Air Quality)

**2.2.5 LIGHT AND POWER LOAD**

Estimate heat gain due to lighting (overhead and task lights) and power (connected and plug-in equipment) loads. Use actual lighting layout and manufacturer's data. Use of any assumed parameters (W/sf or Btuh/sf) is not acceptable in the final design.

**2.2.6 BUILDING THERMAL ENVELOPE**

The building thermal envelope shall be in compliance with the ASHRAE Standard 90.1 – 2007 and shall be based on the actual building construction.

**2.2.7 OUTDOOR AIR FOR VENTILATION (CALCULATION REQUIREMENTS)**

Use the following parameters to estimate the highest value of the minimum outdoor air for ventilation:

- (a) ASHRAE Standard 62.1 – 2007 (Ventilation for Acceptable Indoor Air Quality)
- (b) ASHRAE Handbook of Applications – 2007
- (c) VA Requirement – Minimum 15% of supply air
- (d) Exhaust Air – As specified in the Room Data Sheets

Typical spaces are:

- Housekeeping Aide Closet (HAC)
- Toilets

- Shower Rooms
- Soiled Utility or Storage Rooms
- Locker Rooms
- Kitchen Range Hoods
- Dishwasher Hoods
- Kitchenette
- Transfer Air for Negative Air Balance
- Space Pressurization Allowance

Allow minimum 5% allowance for space pressurization in the overall air balance at the air-handling unit level. See Room Data Sheets for individual room air balance. The allowance can be as high as 10% based on such factors as the number of exit doors to outdoors, operable versus non-operable windows, presence or absence of vestibules, weather stripping of windows, etc.

## **2.3 COOLING AND HEATING LOAD CALCULATIONS**

Using an ASHRAE-based, public domain (DOE) or commercially available software program (Trane, Carrier, or other approved), calculate the following design parameters:

### **2.3.1 ROOM DATA OUTPUT**

The HVAC design parameters shown in each room output data sheet shall be used to create an Excel type spreadsheet that will include additional parameters as shown in the attached matrix (Table 2-1). This spreadsheet is required for each air-handling unit and is a vital tool to facilitate in-depth review.

### **2.3.2 AHU DATA OUTPUT**

#### **2.3.2.1 AHU Peak Cooling Load**

AHU peak load is the maximum cooling load on the air-handling unit due to room sensible, room latent, and total outdoor air for ventilation cooling loads. Note that the AHU peak-cooling load is not the sum of the individual room peak cooling loads, which occur at different times, in different months, and due to differing orientations. If a chiller serves a single air-handling unit, use the AHU peak load to select the chilled water system.

#### **2.3.2.2 AHU Peak Supply Air Volume**

AHU peak supply air volume is calculated from the peak space sensible cooling load without the sensible cooling load due to use of outdoor air for ventilation. Use AHU peak supply air volume for selecting the air-handling unit and air distribution ductwork upstream of the VAV box. For ductwork downstream of the VAV box, use the individual room peak supply air volumes. The return air duct shall be sized based on peak AHU supply air volume. The return air branch from the room shall be sized based on room peak supply air volume.

#### **2.3.2.3 AHU Supply Air Volume and Duct Leakage Factor**

Calculated AHU peak supply air volume shall be rounded off to the next 100 cfm or 10 L/s and increased by 5% to account for the air leakage due to ductwork and the system components. Increase the supply air volume by an additional 5% safety factor. Thus, the calculated supply air volume shall be increased by a total of 10.25%:

AHU Supply Air Volume: Calculated Supply Air Volume x 1.05 (Leaking Allowance) x 1.05 (Safety Factor) = 1.1025, that is, 10.25%

## CHAPTER 2: HVAC DESIGN PARAMETERS AND SELECTION CRITERIA

### 2.3.2.4 Psychrometric Analysis

Provide psychrometric analysis for each air-handling unit by using software programs. The calculated and graphic display of the system performance shall include the following:

- Outdoor and indoor design conditions
- Mixed air conditions
- Coil leaving air conditions
- Heat gain due to supply and return air fans
- Supply air volume
- Cooling, heating, and humidification loads

### 2.3.3 BUILDING PEAK COOLING LOAD

Building peak cooling load is the maximum cooling load due the space sensible and latent loads and the peak cooling load due to the ventilation demand of the entire building, treated as one room. Building peak cooling load is not the sum of the peak cooling loads of the individual AHUs. Use building peak cooling load to select the cooling system.

## 2.4 ROOM TEMPERATURE CONTROLS

### 2.4.1 DEFINITION

A space is defined as individually controlled only when a dedicated terminal unit (air terminal unit, fan coil unit, heat pump, or any other heating and/or cooling device) and a dedicated room temperature sensor are used to control the space temperature.

#### 2.4.1.1 Individually Controlled Rooms

Listed below are spaces to be equipped with individual room temperature control. A complete list is given in the Room Data Sheets in [Chapter 3](#).

- Resident Bedroom
- Dining Room
- Conference Room
- Multi-Purpose Room
- Kitchen and Pantry
- Chapel/Meditation

#### 2.4.1.2 Group Temperature Control – Perimeter Offices

A single air terminal unit can serve as many as three offices located on the same exposure with identical load characteristics.

#### **Exception:**

A perimeter corner office with at least two exposures shall be equipped with a dedicated room temperature control.

#### 2.4.1.3 Group Temperature Control – Interior Offices

A single terminal unit can serve as many as four interior office rooms that all have identical functions and load characteristics.

#### 2.4.1.4 Open Spaces

Open spaces with exposed perimeter and interior areas shall be zoned such that one air terminal unit serves the perimeter zones and another serves the interior zones. A perimeter zone is defined as an

area enclosing an exposed length and 12 to 15 ft [4 to 5 m] width. An interior zone does not have exposed walls.

## 2.4.2 PERIMETER HEATING REQUIREMENTS

### 2.4.2.1 General

Provide supplementary perimeter-heating systems for:

- (a) **Resident Bedrooms** – When the room heat loss exceeds 180 Btuh/lin ft [173 W/lin m] of exposed wall.
- (b) **All Other Occupied Spaces** – When the room heat loss exceeds 210 Btuh/lin ft [202 W/lin m] of exposed wall.
- (c) **Energy Conservation** – A building thermal envelope with enhanced energy efficiency can eliminate the need for perimeter heating systems.

### 2.4.2.2 Perimeter Heating System Description

- (a) All resident bedrooms and associated exposed bathrooms and all occupied spaces that qualify for supplementary heating shall use **radiant ceiling panels only**, unless approved otherwise by VA Authorities. During design development, provide coordinated details of the perimeter reflected ceiling plan, showing linear diffusers and radiant ceiling panels. Design shall optimize performance while maximizing aesthetics.
- (b) For all other spaces such as non-patient bathrooms, exterior stairs, vestibules, and unoccupied spaces, thermostatically-controlled perimeter heat shall be delivered by unit heaters, cabinet heaters, convectors, or baseboard radiators.

### 2.4.2.3 Heating Medium

Use heating hot water as the heating medium. Use two-way modulating control valves to control the hot water flow. Minimum flow for each heating circuit shall not be less than 0.5 gpm [0.03 L/s].

### 2.4.2.4 System Sizing and Control Criteria

Ensure that the terminal unit reheat coil and perimeter heating system are correctly sized to share the total heating load and to operate in sequence. For example, if the reheat coil in the terminal air unit is oversized, or not controlled to limit its share of the heating duty, the perimeter heating system shall not be operational.

## 2.5 SPECIAL STUDIES REQUIREMENTS

The A/E shall perform the following two studies to verify the validity of the design. With the scheduled project submission (see A/E Submission Requirements), submit the study reports, complete with recommendations and the estimated construction cost for VA review and approval.

### 2.5.1 ACOUSTIC ANALYSIS

#### 2.5.1.1 General

Perform an acoustic analysis to demonstrate that the specified room noise levels are achieved in all octave bands for all air-handling units, heating and ventilating units, fans, chillers, boilers, generators, and outdoor noise producing equipment, such as cooling towers and chillers. See Room Data Sheets for the required Noise Criteria (NC) levels.



## CHAPTER 2: HVAC DESIGN PARAMETERS AND SELECTION CRITERIA

### 2.5.1.2 Acoustic Mitigation Measures (HVAC Systems – Without Cooling Tower)

- (a) Select equipment with lower sound power levels.
- (b) Locate equipment away from noise-sensitive areas, such as conference rooms and resident bedrooms.
- (c) Provide factory-fabricated sound attenuators in the main ducts, AHU casings, or on the downstream side of the air terminal units as needed to achieve the required noise levels.
- (d) Provide acoustic sound lining in return or exhaust ducts under negative air pressure. Show the full extent of the acoustic lining on the floor plans and cross-sections. Specify expected attenuation in each octave band with the selected lining.
- (e) Radiated or breakout noise in the low frequency range (humming noise) is often ignored and is hard to attenuate. Evaluate and include such measures as the use of thicker gauge ducts and duct configurations shown in the 2007 ASHRAE Handbook of Applications.
- (f) If recommended by the acoustic analysis, select duct velocities lower than those shown in the duct sizing criteria.
- (g) Select louvers with sound baffles, where practical. Select transfer grilles with acoustic treatment.

### 2.5.1.3 Acoustic Mitigation Measures (HVAC Systems – With Cooling Towers)

Attenuation treatment of cooling towers depends upon factors such as local ordinance and functions of the surrounding spaces. The measures suggested below should be evaluated and included as deemed necessary.

- (a) Locate cooling towers away from sensitive areas.
- (b) Select cooling towers with low noise generating fans.
- (c) Include acoustic screening (fencing) around cooling towers to contain the radiated noise. Coordinate this measure with the architects, VA Authorities, and local ordinances.
- (d) Use acoustically-lined louvers, where required.
- (e) Install sound attenuators on the intake and/or discharge sides.
- (f) Include maximum permissible sound power levels measured at 5 ft [2 m] and 55 ft [17 m] from the cooling tower in the equipment schedule.

### 2.5.1.4 Unitary Equipment

The conditioned spaces served by unitary equipment experience higher noise levels compared to the spaces without unitary equipment. For such spaces, an increase of 5 NC (in room noise level) is permitted. Recommended acoustic measures for the spaces served by the unitary equipment are:

- Select equipment at mid-speed for the required output
- Use acoustic lining in the return air ducts for ducted installation
- Use acoustic enclosure over the equipment, where feasible

## **2.5.2 DISPERSION ANALYSIS**

### **2.5.2.1 General**

- (a) The A/E shall perform a computerized dispersion analysis to ensure that odors and hazardous exhaust do not enter the outdoor air intakes and open windows of VA facilities and adjoining properties. The analysis shall be self-certified with back-up data and itemized recommendations.
- (b) Contamination is a serious safety and health issue. It is critical to evaluate and implement the recommendations of the analysis. All recommendations must be implemented even if OSHA and ASHRAE requirements are exceeded.

### **2.5.2.2 Scope of Work**

The dispersion analyses shall include exhaust from the surrounding exhaust systems that are toxic and infectious. Additional sources of exhaust are:

- Emergency Generators
- Vehicular Exhaust
- Kitchen Exhaust
- Boiler Stacks
- Cooling Towers
- Incinerator Exhaust

## **2.5.3 BUILDING THERMAL ENVELOPE (EXISTING FACILITIES ONLY)**

The mechanical designer and the project architect shall jointly examine the existing building thermal envelope and evaluate the possibility of making it energy-efficient. The recommended energy conservation measures shall be validated by the life-cycle cost analysis.

## **2.6 VIBRATION CONTROL**

Selection of vibration isolators shall be according to the matrix given in VA Master Specification 23 05 41 (Noise and Vibration Control for HVAC Piping and Equipment) and the equipment manufacturer's recommendations. Include applicable standard details. Indicate the type of isolation on the equipment schedule.

## **2.7 SEISMIC REQUIREMENTS (HVAC)**

### **2.7.1 COMPLIANCE**

Earthquake-resistive design shall comply with the requirements of latest edition of VA Handbook H-18-8, Seismic Design Requirements, and the International Building Code (IBC 2006).

### **2.7.2 APPLICATIONS**

Earthquake-resistive design for equipment, piping, and ductwork shall be as follows.

#### **2.7.2.1 New Buildings**

For new buildings, apply seismic restraints for equipment as indicated in VA Handbook H-18-8

#### **2.7.2.2 Existing Buildings**

For existing buildings, apply seismic restraints for equipment in locations of Moderate High, High, and Very High Seismic activity, as indicated in VA Handbook H-18-8.

## CHAPTER 2: HVAC DESIGN PARAMETERS AND SELECTION CRITERIA

### 2.7.2.3 New and Existing Buildings – Piping

For new and existing buildings, apply seismic restraints for piping and ductwork in locations of Moderate High, High, and Very High Seismic activity, as indicated in H-18-8.

### 2.7.2.4 Local Codes

Where local Seismic Code is more stringent, comply with local code.

### 2.7.2.5 Omissions

HVAC equipment, ductwork, and piping shall be braced in accordance with the most current edition of the Seismic Restraint Manual Guidelines for Mechanical Systems (issued by SMACNA). There are conditions listed in SMACNA under which seismic bracing may be omitted. However, a design professional shall review and may revoke such omissions for the specific project.

### 2.7.3 CONFORMANCE WITH SMACNA

SMACNA does not cover all conditions, such as providing bracing details for seismic restraints of equipment, details of flexible joints when crossing seismic or expansion joints, or bracing of in-line equipment, etc. Also, in locations of Very High Seismicities, SMACNA details should be used with special care.

### 2.7.4 CALCULATIONS

Unless otherwise shown by SMACNA, provide detailed structural calculations for VA's review on the design of hangers, supports, anchor bolts, welds, and connections. Show sizes, spacing, and length for securing equipment, piping, and ductwork to structural members. The design calculations shall be prepared and certified by a registered structural engineer.

### 2.7.5 DRAWINGS

#### 2.7.5.1 General

Where SMACNA details are incomplete or not applicable, provide necessary seismic restraint details. Coordinate mechanical, architectural, and structural work.

#### 2.7.5.2 Ductwork and Piping Plans and Sections

Show locations of required restraints with reference to SMACNA or special restraint details, whichever is applicable.

#### 2.7.5.3 Equipment Restraints

Provide special details (not covered by SMACNA), where required. Provide special attention to the seismic provision for the suspended equipment.

## 2.8 FIRE AND SMOKE PROTECTION

### 2.8.1 COMPLIANCE

HVAC design and equipment shall be in compliance with NFPA 90A, NFPA 96, NFPA 99, NFPA 101 and other applicable codes with devices, such as fire dampers, smoke dampers, and duct-mounted smoke detectors shown on the drawings where applicable.

While the local codes and ordinances are not binding to VA, wherever possible, such provisions shall be reviewed with VA and implemented upon approval. See Figure 2-1 for typical smoke control for air-handling units.

## **2.8.2 ADDITIONAL REQUIREMENTS**

### **2.8.2.1 Smoke Dampers**

- (a) Provide electrical actuators.
- (b) Installation of smoke dampers and detectors shall be in compliance with the manufacturer's published recommendations for duct clearance distances and elbow locations.
- (c) Specify smoke detectors and dampers shall be hard-wired.
- (d) Provide local audible and visible alarms and remote alarms at the Engineering Control Center (ECC).
- (e) Provide an end-switch on smoke dampers to ensure the dampers are proven fully open before the fan starts.

### **2.8.3 STAIR PRESSURIZATION**

For VA facilities, stair pressurization is not used.

### **2.8.4 ENGINEERED SMOKE CONTROL SYSTEM**

For VA facilities, engineered smoke control systems are not used.

### **2.8.5 ATRIUM SMOKE CONTROL**

See [Chapter 3](#) for the smoke removal system design.

### **2.8.6 ELEVATOR SHAFT VENTING**

#### **2.8.6.1 Compliance**

See rule 100.4 of ANSI.1, Elevator Safety Code.

#### **2.8.6.2 Hardware**

Provide a normally closed, two-position, motorized damper in the hoist way for venting smoke. See VA Standard Detail for additional information. The damper shall open when activated by the space detector located at the top of each elevator hoist way. Status of the hoist way shall be monitored by the DDC controls.

## **2.9 DESIGN CONSIDERATIONS FOR EXISTING BUILDINGS**

While the scope of work and the conditions are project-specific, the following guidelines shall be used where applicable.

### **2.9.1 SITE SURVEY**

#### **2.9.1.1 As-Built Drawings**

Do *not* rely solely on the available as-built drawings. Take photographs and actual measurements where tight conditions prevail and provide cross-sections of such locations.

## CHAPTER 2: HVAC DESIGN PARAMETERS AND SELECTION CRITERIA

### 2.9.1.2 Site Visits

- (a) Coordinate site visits in advance with the VA facility personnel and become familiar with entry, exit, parking, storage, and security requirements.
- (b) Perform an extensive site survey, record crucial measurements, and interview the maintenance and operating personnel to document the actual field conditions, access requirements, and maintenance history of the existing equipment. Include the site survey report in the project submission and describe chronic problems and shortcomings that may impact the project scope of work.
- (c) Should the site survey result in additional work that affects the scope of work, notify the VA Project Manager in writing, as soon as possible. Any additional work resulting from the site survey must be authorized in advance before it is included in the project scope.

### 2.9.2 MODIFICATIONS – EXISTING SYSTEMS

Work on the existing systems shall include the following measures:

#### 2.9.2.1 Steam Radiators

Existing steam radiators shall be dismantled and replaced with hydronic hot water heat. If this measure is not feasible, the existing radiators shall be equipped with modulating control valves, controlled by the room thermostat responsible for cooling the space. A single thermostat shall prevent cooling and heating concurrently.

#### 2.9.2.2 DDC Controls

All new control devices shall be equipped with electric actuators. For a major renovation of an existing facility, where an updated control system is being installed, replace pneumatic with electric actuators.

#### 2.9.2.3 Existing Ductwork

Where connections are made between new and existing ductwork, the existing ductwork shall be pressure tested, thoroughly cleaned, and sanitized to avoid the possibility of contamination.

#### 2.9.2.4 Refrigerant Removal

Refrigerant from existing equipment that is being dismantled and removed shall be handled and stored in containers per EPA guidelines, and disposed of in accordance with EPA guidelines. Consult local VA Authorities for logistical details and support.

### 2.10 PROJECT PLANNING

The HVAC system design and development shall consider the factors listed below:

#### 2.10.1 PHASING

Coordinate the phasing requirements with facility personnel. Phasing will have significant impact on the need for swing space, schedule, and the system design. Testing, Adjusting, and Balancing and Commissioning costs are dependent on phasing. Duplication of efforts shall be minimized.

#### 2.10.2 UTILITY CONNECTIONS AND OUTAGES

Coordinate outdoor utility routing, available capacity, and intended outages with facility personnel. Provide signs showing revised traffic patterns and revisions to parking.

## **2.11 TECHNICAL CONSIDERATIONS**

### **2.11.1 DEMOLITION WORK**

Demolition work shall be clearly documented with points of disconnections and connections clearly shown. The demolition drawings shall show the locations of new shutoff valves, end caps, and blind flanges.

## **2.12 LOCATIONS OF OUTDOOR AIR INTAKES AND EXHAUST AIR OUTLETS**

### **2.12.1 COMPLIANCE – PHYSICAL SECURITY**

Air intakes and exhausts shall be designed in accordance with the Physical Security Design Manual for VA Facilities – Mission Critical Facilities.

### **2.12.2 GENERAL**

Outdoor air intake and exhaust air outlets shall be located to avoid health hazards, nuisance odors, and reduction in capacity of HVAC equipment, and corrosion of equipment caused by re-entry of exhaust air from laboratories, transportation systems, cooling towers, and air-cooled condensers. See specifications for the types of allowable louvers and their limiting velocities and pressure drops.

### **2.12.3 COMMON OUTDOOR AIR INTAKE**

Common outdoor air intake can be used in conjunction with multiple air-handling units, provided the outdoor air intake plenum is partitioned with a dedicated intake for each air-handling unit.

## **2.13 BID PACKAGE COORDINATION**

Ensure that bid documents are coordinated within the mechanical discipline and across architectural and all other engineering disciplines to avoid delays and change orders/claims.

# HVAC DESIGN MANUAL

CHAPTER 2

FIGURE 2-1

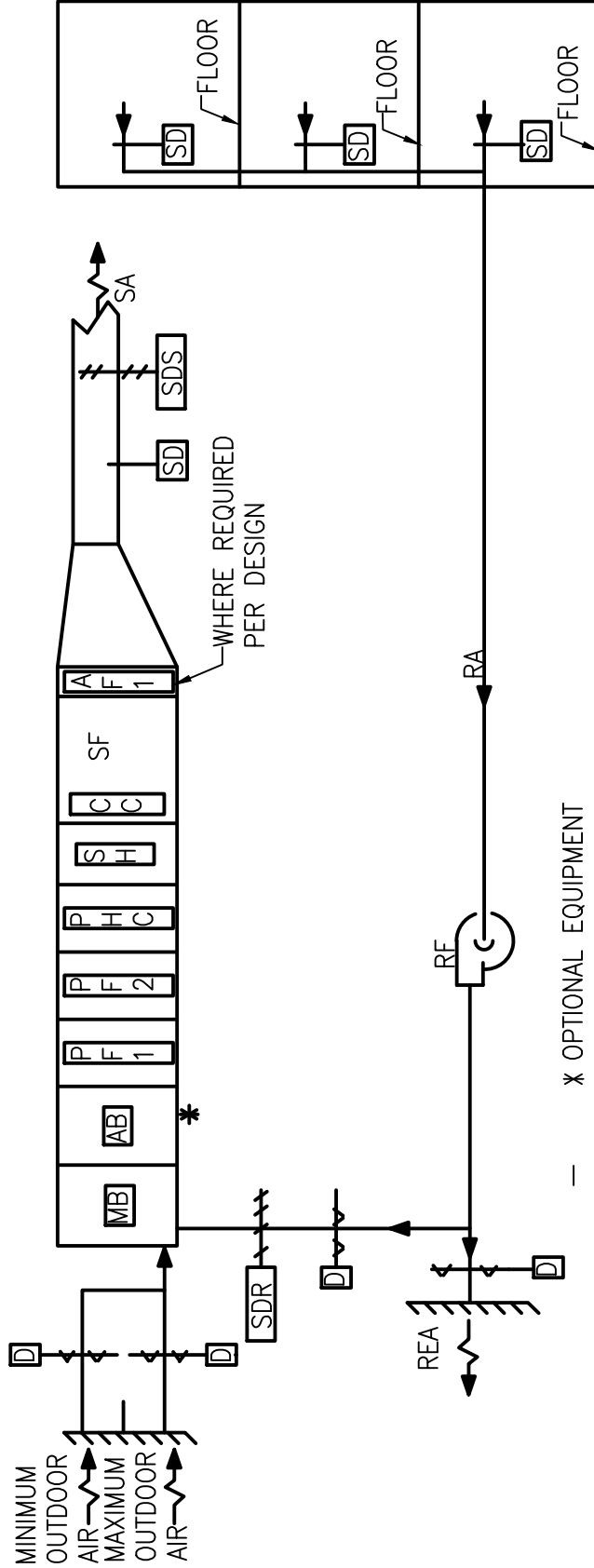

**NOTES:**

1. THIS DIAGRAM IS APPLICABLE TO SYSTEMS WITH A DESIGN CAPACITY GREATER THAN 15,000 CFM [7,075 L/S] AND SERVING MULTIPLE FLOORS.
2. SMOKE DAMPERS ARE NOT REQUIRED IF AHU IS LOCATED ON FLOORS SERVED AND SERVES ONLY THAT FLOOR OR LOCATED ON ROOF DIRECTLY ABOVE FLOOR SERVED. SEE NFPA 90A.
3. SEE STANDARD DETAILS AND CAD STANDARDS (PG-18-4) LOCATED ON THE TIL FOR A LIST OF ABBREVIATIONS.

## SMOKE CONTROL FOR AIR HANDLING UNIT SYSTEMS

Not to Scale

ROOM COOLING AND HEATING LOADS OUTPUT DATA SUMMARY SCHEDULE																															
AHU NO	ROOM NO	ROOM NAME	ROOM SIZE				AHU SYSTEM TYPE	PEAK ROOM COOLING LOAD				PEAK ROOM HEATING LOAD				CALCULATED ROOM AIRFLOW				REQUIRED ROOM AIRFLOW			SELECTED DESIGN ROOM AIRFLOW		ROOM AIR RETURN EXHAUST (G) EXHAUST (S)	ROOM STATUS		ROOM AIR BALANCE			
			AREA		HEIGHT			SENSIBLE	LATENT		HEATING LOAD		AIRFLOW				AIRFLOW			AIRFLOW		VAV OR CV	(+ ) OR (- ) OR (0)								
			SF	M <sup>2</sup>	FT	M	BTUH		W	BTUH	W	BTUH	W	CFM	L/S	ACH	ΔT	CFM	L/S	ACH	CFM			L/S							

**NOTES:**

1. THIS SCHEDULE IS REQUIRED FOR DESIGN SUBMISSION.
2. PROVIDE 11"x17" SPREADSHEETS TO VA FOR DESIGN SUBMISSIONS.
3. USE MINIMUM AIRFLOW (CFM [L/S]) FOR AIR CHANGE CALCULATIONS. IN MOST CASES, THIS IS THE HEATING AIR FLOW RATE.

**ROOM DATA OUTPUT**  
 Not to Scale



**CHAPTER 3: AIRSIDE HVAC SYSTEMS AND EQUIPMENT**

Table of Contents

3.1	INTRODUCTION .....	3-5
3.1.1	HVAC SYSTEMS.....	3-5
3.2	CENTRAL AIR-HANDLING UNITS (ALL-AIR SYSTEMS) .....	3-5
3.2.1	GENERAL .....	3-5
3.2.2	SPECIAL REQUIREMENTS.....	3-5
3.2.2.1	Terminal Cooling System.....	3-5
3.2.2.2	Blow-Through Air-Handling Units.....	3-6
3.2.2.3	Dual-Duct System.....	3-6
3.2.2.4	Limiting Capacity .....	3-6
3.2.2.5	AHU Configuration.....	3-6
3.2.2.6	Rooftop Air-Handling Units .....	3-6
3.3	AIR-HANDLING UNIT COMPONENTS .....	3-6
3.3.1	SUPPLY AIR FAN .....	3-6
3.3.1.1	General.....	3-6
3.3.1.2	Plenum Fans .....	3-6
3.3.1.3	Return Air Fan .....	3-6
3.3.1.4	Exhaust Fan(s) .....	3-7
3.3.1.5	Motors and Voltages.....	3-7
3.3.1.6	AHU Casing.....	3-7
3.3.1.7	Access Sections and Mixing Box .....	3-7
3.3.1.8	Blender Section .....	3-7
3.3.1.9	Drain Pan.....	3-7
3.3.1.10	Cooling Coils .....	3-7
3.3.1.11	Preheat Coils .....	3-8
3.3.1.12	Unit-Mounted Reheat Coils.....	3-8
3.3.1.13	Corrosion Protection .....	3-8
3.3.1.14	Filtration.....	3-8
3.3.1.15	Humidifier .....	3-9
3.4	ALL-AIR SYSTEM – TYPES.....	3-10
3.4.1	VARIABLE AIR VOLUME (VAV) SYSTEMS.....	3-10
3.4.2	CONSTANT VOLUME SYSTEMS .....	3-10
3.5	TERMINAL HEATING AND COOLING SYSTEMS .....	3-10
3.5.1	FAN COIL UNITS .....	3-11
3.5.1.1	Special Requirements.....	3-11
3.5.1.2	Fan Coil Unit Configuration.....	3-11
3.5.2	GROUND SOURCE HEAT PUMPS (GSHP) .....	3-11
3.5.2.1	General.....	3-11
3.5.2.2	References .....	3-11
3.5.2.3	Selection Parameters.....	3-12
3.5.2.4	Heating/Cooling Loads.....	3-12
3.5.2.5	Life-Cycle Cost Analysis .....	3-12
3.5.2.6	Recommendations.....	3-13
3.6	MINIMUM VENTILATION AIR-HANDLING UNITS (100% OUTDOOR AIR UNIT) .....	3-13
3.6.1	GENERAL .....	3-13
3.6.2	FILTRATION.....	3-13
3.6.3	VENTILATION AIR CONTROL .....	3-13
3.6.4	VENTILATION AIR OUTLETS .....	3-13
3.7	HEATING AND VENTILATION SYSTEMS (HVV) .....	3-13
3.7.1	GENERAL .....	3-13
3.7.2	SYSTEM CONFIGURATION .....	3-13

3.8	HEAT RECOVERY SYSTEMS .....	3-14
3.8.1	GENERAL .....	3-14
3.8.2	SENSIBLE HEAT TRANSFER.....	3-14
3.8.2.1	Run-Around System .....	3-14
3.8.2.2	Fixed Plate System (Air-to-Air).....	3-14
3.8.2.3	Heat Pipes .....	3-14
3.8.3	SENSIBLE AND LATENT HEAT TRANSFER.....	3-14
3.8.3.1	Desiccant (Enthalpy) Heat Wheels.....	3-14
3.8.3.2	Energy Savings (Impact on Equipment Selection) .....	3-14
3.8.3.3	Exceptions .....	3-15
3.9	EXHAUST SYSTEMS.....	3-15
3.9.1	GENERAL EXHAUST SYSTEM .....	3-15
3.9.1.1	System Components .....	3-15
3.9.2	SPECIAL EXHAUST SYSTEMS (DEDICATED EXHAUST SYSTEMS).....	3-15
3.9.2.1	Design Considerations.....	3-15
3.10	AIR DISTRIBUTION .....	3-16
3.10.1	MANDATORY REQUIREMENTS .....	3-16
3.10.1.1	Plenum Return System.....	3-16
3.10.1.2	Construction Drawings.....	3-16
3.10.2	DUCTWORK .....	3-16
3.10.2.1	Duct Materials.....	3-16
3.10.2.2	Flexible Ductwork .....	3-16
3.10.2.3	Minimum Duct Size.....	3-16
3.10.2.4	Duct Sizing Criteria.....	3-16
3.10.2.5	Duct Pressure Classification .....	3-17
3.10.2.6	Exposed Ductwork.....	3-17
3.10.3	AIR TERMINAL UNITS.....	3-17
3.10.3.1	General.....	3-17
3.10.3.2	Limiting Capacities.....	3-17
3.10.3.3	Air Distribution Outlets/Inlets.....	3-17
3.11	APPLICATIONS.....	3-18
3.11.1	GENERAL .....	3-18
3.11.2	AIR-HANDLING UNITS ZONING CRITERIA .....	3-18
3.11.2.1	Selecting Air-Handling Units .....	3-18
3.11.2.2	Considerations.....	3-18
3.11.2.3	Home and Community Center.....	3-18
3.11.2.4	Common Spaces .....	3-19
3.11.2.5	Enclosed Circulation Spaces .....	3-19
3.11.2.6	All Air Systems – AHU System Data Sheets .....	3-19
	ATRIUM – AIR-HANDLING UNIT .....	3-20
	AHU System Data Sheet.....	3-20
	AUDITORIUMS AND THEATERS – AIR-HANDLING UNIT .....	3-21
	AHU System Data Sheet.....	3-21
	GYMNASIUM – AIR-HANDLING UNIT .....	3-22
	AHU System Data Sheet.....	3-22
	HOME AND COMMUNITY CENTER – AIR-HANDLING UNIT.....	3-23
	AHU System Data Sheet.....	3-23
	KITCHEN (FOOD PRODUCTION) – AIR-HANDLING UNIT .....	3-24
	AHU System Data Sheet.....	3-24
	MINIMUM VENTILATION AIR – AIR-HANDLING UNIT .....	3-26
	AHU System Data Sheet.....	3-26
	STANDALONE SMOKING FACILITY – AIR-HANDLING UNIT .....	3-27
	AHU System Data Sheet.....	3-27

**CHAPTER 3: AIRSIDE HVAC SYSTEMS AND EQUIPMENT**

3.12	ROOM DATA SHEETS.....	3-28
3.12.1	GENERAL .....	3-28
3.12.2	TERMINAL HVAC SYSTEMS.....	3-28
	COMMUNITY CENTER – ROOM DATA SHEETS.....	3-29
	Bistro .....	3-29
	Chapel/Meditation .....	3-29
	Concierge Station .....	3-29
	Conference Room.....	3-29
	Copy Room.....	3-29
	Garage.....	3-29
	Great Room .....	3-30
	HAC.....	3-30
	Hair Care (Barber/Beauty) .....	3-30
	Media Center .....	3-30
	Multi-Purpose Room .....	3-30
	Offices – Activities Director/Administrators/Maintenance/Nursing .....	3-30
	Public Toilets .....	3-30
	Satellite Telephone/Communications Closet.....	3-31
	Staff Lounge and Lockers .....	3-31
	Staff Toilet.....	3-31
	Storage – Multi-Purpose Room/General/Maintenance .....	3-31
	Vestibule.....	3-31
	COMMUNITY CENTER – MISCELLANEOUS SPACES – ROOM DATA SHEETS .....	3-32
	Attic Space.....	3-32
	Crawl Space (Pipe Basement) .....	3-32
	Electrical Equipment Rooms (EER).....	3-33
	Electrical Equipment Closets without Internal Heat Gain.....	3-33
	Satellite and Main Electrical Rooms with Internal Heat Gain.....	3-33
	Exterior Stairs .....	3-33
	Mechanical Equipment Rooms (MER) .....	3-34
	Air-Handling Equipment Rooms.....	3-34
	Heating Rooms.....	3-34
	Refrigeration Equipment Rooms .....	3-35
	COMMUNITY CENTER – OPTIONAL SPACES – ROOM DATA SHEETS.....	3-36
	Examination Room.....	3-36
	Pharmacy .....	3-36
	Physician Office .....	3-36
	Receiving/Loading .....	3-36
	Security Office .....	3-36
	HOME – ROOM DATA SHEETS .....	3-37
	Bathing Suite .....	3-37
	Bedroom – Resident.....	3-37
	Bedroom – Special Care Resident.....	3-37
	Clean Linen Closet.....	3-37
	Corridor.....	3-38
	Den.....	3-38
	Dining Room.....	3-38
	Foyer .....	3-38
	Garage.....	3-38
	HAC.....	3-38
	Hair Care (Barber/Beauty) .....	3-38
	Home Entry/Front Porch .....	3-39
	Home Office.....	3-39

Home Storage.....	3-39
Kitchen and Pantry.....	3-39
Kitchen Housekeeping Closet .....	3-39
Laundry.....	3-39
Living Room.....	3-39
Soiled Utility Room.....	3-40
Toilet – Public .....	3-40
Toilet – Special Care Resident.....	3-40
Toilet and Showers – Resident .....	3-40

### 3.1 INTRODUCTION

This chapter describes HVAC systems to meet the needs of the Community Living Center, Domiciliary, and associated support functions, collectively referred to as the Facilities in this document. Information given below shall be used in conjunction with the VA Standard Details and Master Specifications, and the associated documents described in [Chapter 1](#) and located on the TIL.

#### 3.1.1 HVAC SYSTEMS

The following HVAC systems are evaluated:

- Central Air-Handling Units (All-Air Systems)
- Variable Air Volume (VAV) Systems
- Terminal Heating and Cooling Systems (Fan Coil Units and Ground Source Heat Pumps (GSHP))
- Minimum Ventilation Air-Handling Units (100% Outdoor Air Units)
- Heating and Ventilation Units (HVU)
- Heat Recovery Systems

The designer is encouraged to investigate and propose other viable systems for the review and approval of VA Authorities. Veteran's comfort and safety, cost-effectiveness, and compliance with this manual shall not be compromised when proposing alternative systems.

### 3.2 CENTRAL AIR-HANDLING UNITS (ALL-AIR SYSTEMS)

#### 3.2.1 GENERAL

Evaluate the use of all-air systems, where feasible and justified by the life-cycle cost analysis. All air-handling units shall be AHRI-certified, factory-fabricated, and the standard product of one manufacturer. Use of custom-built air-handling units is NOT permitted. The air-handling units shall be constructed in modular, vertical or horizontal, and draw-through configuration. See Figure 3-1 for a typical air-handling unit configuration.

At the end of this chapter, in the Applications Section, the following issues are discussed:

- AHU Zoning Criteria
- Dedicated Air-Handling Units
- AHU Design Data Sheets
- Room Data Sheets
- Special Applications

#### 3.2.2 SPECIAL REQUIREMENTS

##### 3.2.2.1 Terminal Cooling System

The following terminal cooling systems were examined by Facilities Quality Service:

- Radiant Ceiling Panels
- Chilled Beams (Active and Passive)
- Valance Systems

Based on the life-cycle cost analysis, using a minimum of four air changes per hour (total) for a Resident Bedroom (using the same criteria for the patient bedroom stipulated in ASHRAE Standard 170-2008, Table 7-1, Note V), the above systems are not proven to be cost-effective and shall not be used.

### **3.2.2.2 Blow-Through Air-Handling Units**

Use of blow-through air-handling units is not permitted, as fully saturated air leaving the cooling coil causes damage to the filters and sound attenuators located downstream of the cooling coils.

### **3.2.2.3 Dual-Duct System**

Generally, a single-zone, single-duct all-air system is used to serve the occupied spaces. However, use life-cycle cost analysis to evaluate and compare the feasibility of a dual-duct all-air system.

### **3.2.2.4 Limiting Capacity**

Capacity of a single air-handling unit shall not exceed 50,000 cfm [23,585 L/s].

### **3.2.2.5 AHU Configuration**

Each air-handling unit shall be installed as a standalone entity without any physical interface with another air-handling unit. Selection of stacked (one on the top of another) air-handling units is not permitted. Use of a common return air fan for two or more air-handling units is also not permitted.

### **3.2.2.6 Rooftop Air-Handling Units**

Rooftop air-handling units are not permitted in high humidity areas as defined in this manual. Rooftop air-handling units are not permitted in hurricane areas, as defined in the Physical Security Manuals (Mission Critical Facilities).

## **3.3 AIR-HANDLING UNIT COMPONENTS**

### **3.3.1.1 SUPPLY AIR FAN**

#### **3.3.1.2 General**

Selection of the supply air fan shall be project-specific based on multiple selections showing a comparison between a housed airfoil centrifugal fan and a single or multiple (generally not more than four fans in an array) plenum fans. The selections shall be reviewed and approved by VA. The supply air volume and static pressure shall be adjusted for altitude, temperature, and inlet/outlet conditions (system effect). The fan selection shall be based on the evaluation of bhp absorbed, sound power data (discharge and radiated), and overall dimensions while comparing multiple selections.

#### **3.3.1.3 Plenum Fans**

##### **(a) General**

Selection of plenum fans shall be based on the following:

- Direct-Drive Fans (Belt-Drive is not acceptable)
- Variable-Speed Drives
- Aluminum Wheels (Dynamically Balanced and Internally Isolated)

##### **(b) Certification and Testing Requirements**

All fans shall be AMCA certified, individually. Multiple fans in an array are not AMCA certified. AMCA 210 certification is required for air performance and AMCA 300 certification for sound power ratings. The air-handling unit, equipped with plenum fans, shall be rated and/or certified by AHRI-430 (airflow) and AHRI-260 (sound). Per current information, only a single fan installation is AHRI certified.

#### **3.3.1.4 Return Air Fan**

Where room air is permitted to be returned back to the system, provide a dedicated return or relief air fan for each air-handling unit to facilitate room-by-room air balance, economizer cycle, and intended

volumetric air balance. Provide a direct digital control (DDC) interlock between the supply and return/relief air fans.

### 3.3.1.5 Exhaust Fan(s)

Provide general and special exhaust fan systems (as required), DDC interlocked with the AHU supply air fan. A single AHU may require interlocks with multiple exhaust fan systems, such as fume hood exhaust, wet exhaust, and general exhaust.

### 3.3.1.6 Motors and Voltages

All motors shall be certified premium efficiency as required by Federal Energy Management Program (FEMP).

### 3.3.1.7 AHU Casing

The AHU casings shall be solid double-wall, without perforations. Provide thermal insulation between the inner and outer casings. Use of exposed interior insulation is not permitted. Combination of the casing wall thickness and the insulation characteristics (insulation type, thickness, and density) shall:

- (a) Provide stiffness to resist dents
- (b) Limit vibration within the prescribed values
- (c) Limit inlet, discharge, and casing-radiated noise
- (d) Avoid condensation on the exterior surface of the air-handling unit or its viewing windows when it is located in non-conditioned spaces, such as mechanical rooms, basements, and attic spaces.

### 3.3.1.8 Access Sections and Mixing Box

Include access sections generally as shown in Figure 3-1. Show door swings on the floor plans. Include a factory-fabricated mixing box to mix the return and outdoor airstreams. Pre-filters shall not be located in the mixing box.

### 3.3.1.9 Blender Section

Provide a blender section, where warranted, to mix return and supply air and prevent stratification.

### 3.3.1.10 Drain Pan

Provide an insulated, stainless steel, double-wall, and double sloping drain pan for removing cooling coil condensate from the pan as soon as it forms. Where two coils are stacked on top of each other, include an intermediate drain pan for draining condensate from the upper coil into the main drain pan. Raise all floor-mounted air-handling units above the finished floor level to obtain adequate static head for the installation of cooling coil condensate traps.

### 3.3.1.11 Cooling Coils

Provide chilled water or direct expansion (DX) cooling coils constructed of copper tubes and aluminum fins. Select cooling coils to limit the face velocity to 500 fpm [2.5 m/s] or below and the fin spacing shall not exceed 132 fins/ft [433 fins/m]. Evaluate the possibility of lowering the cooling coil face velocity if life-cycle cost-effective.

### 3.3.1.12 Preheat Coils

Provide preheat coils for all AHUs where the winter design temperature is 32 F [0 C] or below. Preheat coils are required when the mixed air temperature is lower than the supply air temperature. Provide steam, hot water/glycol, hot water, or electric pre-heat coils. Generally, select the same face velocity as for the cooling coil to avoid blank offs.

#### (a) Steam Heating Coils

Select steam coils with integral face and bypass dampers and two-position on/off control valves. As an option, for non-100% outdoor air units, consider the use of a distributing type steam coil with a modulating control valve. The design shall ensure that the steam condensate is removed from the coil as soon as it is formed by selecting the correct steam trap size and type, adequate height for the gravity drain leg (static height), and recommended slope for the gravity return.

#### (b) Hot Water/Glycol Coils

Where the use of steam preheat coils is not feasible, use hot water/glycol preheat coils where the preheat coil surface comes in contact with below freezing air temperature. Use propylene glycol solution with corrosion inhibitors specifically manufactured for HVAC applications. See [Chapter 4](#) for glycol properties.

#### (c) Hot Water Coils

Glycol can be omitted where the heating design temperature (ASHRAE Annual Extreme Daily Mean Dry-Bulb Temperatures – Minimum Column) is 32 F [0 C] and above. The following freeze protection measures are recommended:

- (1) Provide a dedicated circulating pump in the coil circuit with hydronic separation between the coil circuit and the incoming hot water piping to maintain a constant water velocity through the preheat coil tubes of 3.0 fps [0.9 m/s] (See VA Standard Detail, Hot Water Preheat heating Coil and Inline Pump).
- (2) Select coils with wider fin spacing at the rate of 6 or 8 fins/in [2.5 or 3.0 fins/cm].
- (3) Provide coil connections to ensure that the coldest air faces the hottest fluid.

#### (d) Electric Coils

Electric preheat coils may be used only where steam and hot water are not available. Select low-watt density electric coils complete with UL safety devices and Silicon Controlled Rectifier (SCR) controls for modulating operation.

### 3.3.1.13 Unit-Mounted Reheat Coils

Air-handling mounted reheat coils are used for single-zone application and elsewhere required. Hot water or steam coils with modulating control valve shall be the preferred choice. Electric reheat coils may be used where hot water or steam are not available.

### 3.3.1.14 Corrosion Protection

In high-humidity locations, all unit-mounted coils shall be protected from corrosion by multi-stage electro-deposit coating of 1 mil thick epoxy lining.

### 3.3.1.15 Filtration

Each air-handling unit shall be provided with two pre-filter sections. Pre-filters shall be located on the upstream side of the coil sections. Filter face velocity shall not exceed 500 fpm [2.5 m/s].



**(a) Filter Pressure Drops**

The fan static pressure shall be calculated using the manufacturer's published static pressure drop at the recommended changeover condition and not at the clean condition.

**(b) Filter Efficiency**

Filter efficiencies shall comply with ASHRAE Standard 52.2 – 2007 (Method of Testing General Ventilation Air-Cleaning Devices for Removal Efficiency by Particle Size). All filter efficiencies shall be expressed as MERV (Minimum Efficiency Reporting Value).

**(1) PF-1**

MERV Rating = 7  
Filter Size = 2 in Thick Throwaway

**(2) PF-2**

MERV Rating = 11  
Filter Size = 6 in Thick Throwaway

**(c) Instrumentation**

**(1) Manual Pressure Gauges**

Provide a single dial-type differential pressure gauge with air sampling tubing and three isolation valves (ball valves) to measure static pressure across each bank of the pre-filter section and the total static pressure drop across both pre-filter sections.

**(2) DDC Sensors**

Provide a dedicated DDC pressure differential switch for each filter section. The DDC switch shall interface with the building ECC system to provide a remote maintenance alarm, when the pressure drop exceeds the switch alarm setting.

**3.3.1.16 Humidifier**

**(a) General**

Provide a unit-mounted steam humidifier to maintain the zone relative humidity at the set point. The humidifier shall be jacketed type designed to attain full dispersion of steam in the airstream. Duct-mounted steam humidifiers are permitted for renovation projects in existing buildings, where space conditions are tight. Provide drainable stainless steel ductwork upstream and downstream of the humidifier.

**(b) Humidifier Controls**

Provide a modulating steam control valve to control and maintain space humidity. Provide a return or exhaust air duct-mounted sensor to control the humidity set point. Provide a high-limit humidity sensor in the supply air duct to disable humidification if the discharge humidity exceeds 85% (adjustable). Ensure full integration of the humidifier controls with the ECC, including remote alarm capability.

**(c) Boiler Plant Steam**

Steam from the central boiler plant may be used only if it is documented that the chemicals used for the water treatment are FDA and OSHA approved.

**(d) Dedicated Steam Generator**

Where direct use of the central boiler plant steam is not feasible, an unfired steam-to-steam generator shall be used to produce "clean steam" at 15 psig. Incoming water shall be de-ionized or reverse-osmosis treated as recommended by the generator manufacturer. Determine water quality based on the site sample.

**(e) Gas-Fired Humidifiers**

Where central boiler plant steam is not available, evaluate the possibility of using a gas-fired steam generator.

**3.4 ALL-AIR SYSTEM – TYPES**

**3.4.1 VARIABLE AIR VOLUME (VAV) SYSTEMS**

**(a) General**

VAV systems shall be used where feasible. The systems shall be designed to vary the supply air volume in response to the prevailing cooling load per control sequence outlined below.

**(b) System Components**

The system design shall include:

- Variable speed drives for supply and return/relief air fans
- Airflow measuring devices in supply, return, and minimum outdoor air ducts
- Static Pressure Sensor
- Pressure independent air terminal units

**(c) Control Sequence**

Supply air fan speed shall be controlled by polling all air terminal units and/or by controlling the duct static pressure. Airflow measuring devices shall facilitate a tracking sequence in which a constant differential between the supply and return/relief air volumes shall be maintained. Limit the tracking and speed reduction sequences to avoid return/relief air fan stalling while maintaining minimum outdoor air.

**(d) Economizer Cycle**

Incorporate economizer cycle as mandated by ASHRAE Standard 90.1 – 2007 and where found cost-effective by life-cycle cost analysis.

**(1) Airside Economizer Cycle**

When a dry-bulb temperature activated economizer cycle is used, selection of the switchover temperature shall not result in higher dehumidification or humidification loads.

**(2) Waterside Economizer Cycle**

The system shall consist of a hydronic circuit using cooling tower water in conjunction with a plate heat exchanger and a circulating pump. The system shall deliver cold water at +/- 45 F [+/- 7 C] into the distribution loop of the central chilled water plant to meet the winter cooling load and if possible postpone start-up of a central plant chiller at low-load conditions.

**3.4.2 CONSTANT VOLUME SYSTEMS**

Constant volume systems are similar to VAV systems, with the exception that supply and return air volumes remain constant throughout the system operation. Provide airflow measuring device for the outdoor air duct only.

**3.5 TERMINAL HEATING AND COOLING SYSTEMS**

**(a)** In this section, two types of terminal units (fan coil units and ground source heat pumps) are described for use with 100% outdoor air minimum ventilation air units.

**(b)** The use of radiant ceiling panels for cooling applications is not permitted.

**(c)** The use of valence cooling systems is not permitted.

- (d) The use of water source heat pumps with auxiliary equipment is not addressed in this manual. These systems are acceptable and shall be evaluated if the facility has significant spaces requiring year-around cooling.

### 3.5.1 FAN COIL UNITS

The use of four-pipe fan coil systems is permitted for occupied spaces if proven cost-effective per life-cycle cost analysis. Use of two-pipe seasonal changeover fan coil systems is not permitted.

#### 3.5.1.1 Special Requirements

##### (a) Minimum Outdoor Air for Ventilation

Minimum outdoor air (raw or conditioned) is not permitted to be admitted into, or distributed through, the fan coil units. Conditioned outdoor air for ventilation shall be directly admitted into the occupied spaces by a fully-ducted air distribution system.

##### (b) Interior Spaces

Use of fan coil units for the interior spaces shall be carefully evaluated on a case-by-case basis. An interior space can be conditioned by the minimum ventilation air, that is, 100% outdoor air. While this approach is not energy-efficient, it provides substantial savings in initial capital cost. Use of a heat recovery system may partially counteract the higher energy consumption when using a 100% outdoor air system. Provide a duct-mounted reheat coil for space temperature control.

#### 3.5.1.2 Fan Coil Unit Configuration

Fan coil units shall be either floor-mounted vertical or suspended horizontal configuration. Where possible, locate vertical units under windows to control cold drafts and solar radiation. Suspended units shall be recessed or concealed in the ceiling and provided with air distribution ductwork as needed. Provide manufacturer's standard filters. Provide a two-way, modulating control valve for each coil to operate cooling and heating modes in sequence with a built-in, adjustable dead-band.

Ensure that the cooling coil condensate is removed from the drain pan and drain lines. Minimize the extent of horizontal runs and provide cleanouts at each turn in the direction of flow. Pitch the drain line in the direction of flow to facilitate gravity flow.

### 3.5.2 GROUND SOURCE HEAT PUMPS (GSHP)

#### 3.5.2.1 General

Evaluate the use of the GSHP system based on the life-cycle cost analysis. Numerous studies completed by trade and industry groups show that GSHP systems are a highly energy-efficient HVAC system.

#### 3.5.2.2 References

The designer is urged to review valuable information available from the following:

##### (a) Department of Energy

<http://www1.eere.energy.gov/geothermal/maps>

##### (b) The International Ground Source Heat Pump Association (IGSHPA)

Publication: Design and Installation Standards 2007

### 3.5.2.3 Selection Parameters

#### (a) Vertical or Horizontal Bores

Evaluate the use of ground heat exchanger based on numerous considerations, such as availability of land, presence or absence of rock and soil composition, etc.

#### (b) Test Bore

Conduct thermal-properties test by drilling a vertical test bore. The advantages of this approach are:

- Optimization of the loop design based on the actual data rather than assuming worst-case scenario
- The test-loop can be used as part of the permanent heat exchanger

#### (c) Pipe Selection

Generally thermally-fused, high-density polyethylene (HDPE) tubes are used for vertical bores. The sizes vary with the depth of the bore from 1 in to 1.5 in [25 mm to 38 mm].

#### (d) Loop Types

Selection of the loop type shall be project specific. The designer must evaluate the site for loop placement knowing that use of the property may be very limited for future use or expansion. The designer shall determine if heavy excavation and drilling equipment can access the site. The designer shall be familiar with federal, state, and local codes for drilling of water wells and geothermal boreholes. Check local agencies for this information. Generally three different types of loops are used:

- Unitary Loop
- Sub-central Loop
- Central Loop

### 3.5.2.4 Heating/Cooling Loads

The block heating and cooling loads are used to determine the maximum heat extracted during the design heating hour and the maximum heat addition to the ground loop during the design cooling hour. These two loads are used to size the ground heat exchanger. In the final design phase, peak zone loads and block loads will be used in sizing pumps, plate and frame heat exchangers, and piping systems. The piping system consists of the interior condenser water loop and the exterior ground loop.

The ground heat exchanger must be sized to maintain the design fluid-loop temperature within the minimum and maximum temperature limits for which the heat pumps are selected at all times. Also, it must be sized to maintain those temperatures over the expected life of the system. If the heat exchanger is sized too small, the ground temperature will rise over a period of time.

### 3.5.2.5 Life-Cycle Cost Analysis

Based on estimates of soil characteristics developed from the site survey, the designer can model the “conceptual loop design.” This conceptual loop design will be used to estimate the cost of the geothermal ground loop based on local drilling and labor rates. The ground loop cost will then be entered into the life-cycle analysis program for comparison to other systems.

The average life of a water source heat pump is estimated to be 19 years. The average life of a cooling tower is 10 to 15 years, depending on the geographical location and maintenance. The average life of a boiler is 25 years. In comparison, high density polyethylene piping material used in geothermal systems has a guarantee of 25 years from the pipe manufacturer.

### 3.5.2.6 Recommendations

To summarize:

- Use peak block load and building operational characteristics. The building block load is the sum of all actual cooling loads, not adding up heat pump capacities.
- Specify efficient heat pumps (minimum of 13 EER at ARI/ISO 13256-1).
- More zones (smaller tonnage units have higher efficiencies).
- Design for minimum 20 ft [6 m] borehole spacing. Spacing the holes further apart helps ensure that boreholes do not affect one another.
- Use small diameter boreholes with a high conductivity grout.
- Know the site (test bores, well logs, thermal conductivity test).
- Do not over-pump – maximum of 2.5 - 3.0 gpm/Ton [0.16 - 0.19 L/s/Ton] flow rate
- Low pump power – maximum of 7.5 hp/100 ft [0.18 kW/m].
- Design for simple installation (flushing, pipe size, headering). Installation requirements shall include provisions for flushing all air and debris out of pipes, manifolding pipes together, etc. The design can either make these installation steps easy or next-to-impossible.

## 3.6 MINIMUM VENTILATION AIR-HANDLING UNITS (100% OUTDOOR AIR UNIT)

### 3.6.1 GENERAL

See [Chapter 2](#) and Room Data Sheets for the estimation of minimum outdoor air for ventilation. Provide heat recovery systems as mandated by ASHRAE Standard 90.1 – 2007.

### 3.6.2 FILTRATION

The filtration requirements shall be similar to all-air systems.

### 3.6.3 VENTILATION AIR CONTROL

Do not deliver minimum ventilation air at “neutral” condition, where air is reheated up to the room air temperature after dehumidification. Provide dynamic control of the ventilation air temperature to take full advantage of its available cooling capacity in cooling mode and heating capacity in heating mode. Ensure that the variations in the ventilation air temperature do not compromise dehumidification.

### 3.6.4 VENTILATION AIR OUTLETS

Minimum ventilation air outlets shall be designed to provide the required air volume and throw to the occupied areas. With smaller ventilation air volumes of 20 cfm [9 L/s] and below, selection of outlets capable of providing adequate throw is necessary. Evaluate the use of the jet type of side outlets, generally used in aircrafts.

## 3.7 HEATING AND VENTILATION SYSTEMS (HVU)

### 3.7.1 GENERAL

Heating and/or ventilation systems shall be provided where mechanical cooling is not required.

### 3.7.2 SYSTEM CONFIGURATION

HVU systems can be designed in any viable configuration to suit the application. The HVU can be composite units, similar to the conventional air-handling units, capable of providing both ventilation and heating. Alternately, providing heating and ventilation can be accomplished using separate heating and ventilation units.

### **3.8 HEAT RECOVERY SYSTEMS**

#### **3.8.1 GENERAL**

Evaluate and include the use of a heat recovery system as stipulated in ASHRAE Standard 90.1 – 2007. To comply with the mandated energy reduction of 30% over ASHRAE 90.1 – 2004, the designer shall extend the evaluation to include those systems which may not fall under the mandate of ASHRAE 90.1 – 2007, but appear to be qualified for the heat recovery system. For such systems, determination shall be made on the basis of life-cycle cost analysis.

#### **3.8.2 SENSIBLE HEAT TRANSFER**

Generally suitable for dry climate.

##### **3.8.2.1 Run-Around System**

- (a) Used for pre-heating and pre-cooling outdoor air.
- (b) Evaluate and use glycol solution and defrost cycle to prevent freezing.

##### **3.8.2.2 Fixed Plate System (Air-to-Air)**

- (a) No direct air-to-air contact.
- (b) No transfer media.

##### **3.8.2.3 Heat Pipes**

- (a) Heat source boils a heat transfer fluid and a heat sink condenses the fluid back to its liquid state, liberating the energy transferred from the fluid's phase change.
- (b) Transfer fluid is contained within a pipe.
- (c) Supply and exhaust airstreams must be in close proximity. Use sealed-tube thermosyphon.
- (d) Corrosion resistance of the pipe must be ensured.

#### **3.8.3 SENSIBLE AND LATENT HEAT TRANSFER**

##### **3.8.3.1 Desiccant (Enthalpy) Heat Wheels**

- (a) The use of a three Angstrom molecular sieve provides sensible and latent energy recovery with a very low level of cross-contamination between the incoming outdoor air and exhaust system discharge.
- (b) Heat transfer efficiency of 75-90%.
- (c) No wet surfaces to support microbial growth or chemical byproducts associated with boiler steam humidification.
- (d) Ensure outdoor air is pressurized greater than exhaust air.

##### **3.8.3.2 Energy Savings (Impact on Equipment Selection)**

When sizing and selecting the capacities of the HVAC equipment, assume heat recovery devices are not utilized. HVAC equipment sizing shall be based on a system without heat recovery devices installed. The heating and cooling energy savings, however, can be projected into the energy analysis

and life-cycle cost analysis. Include two sets of operating conditions in the equipment schedule, one with and one without heat recovery devices.

### 3.8.3.3 Exceptions

Heat recovery is not permitted from:

- (a) Kitchen grease hood exhaust.
- (b) Kitchen wet exhaust.
- (c) Exceptions outlined in ASHRAE Standard 90.1 – 2007.

## 3.9 EXHAUST SYSTEMS

Provide general or special exhaust systems as required to meet the specific needs of the application.

### 3.9.1 GENERAL EXHAUST SYSTEM

Provide a general exhaust system to serve:

- Toilets
- Combination – Toilets and Showers
- HAC
- Locker Rooms
- Storage Rooms – Soiled or Clean
- Kitchen Heat Exhaust Hoods (Canopy Hoods)

With a central ventilation system (for minimum outdoor air), the scope of the exhaust system shall extend to all occupied spaces.

#### 3.9.1.1 System Components

- Exhaust Fan
- Exhaust Air Intake Ductwork
- Exhaust Air Inlets
- Exhaust Air Discharge Arrangement (louvers, where required)
- Motorized Damper (interlocked with exhaust fan)
- Controls (interlock with supply air system)

### 3.9.2 SPECIAL EXHAUST SYSTEMS (DEDICATED EXHAUST SYSTEMS)

Special exhaust systems are dedicated to serve kitchens, classified as commercial kitchens, for applications such as kitchen grease exhaust and wet exhaust from dishwasher. The system components are similar to the general exhaust system except the use of the dampers is not allowed for grease exhaust air systems.

#### 3.9.2.1 Design Considerations

##### (a) Kitchen Grease Exhaust System

See dedicated air-handling unit serving Kitchen (Food Production).

##### Exception:

For kitchenettes, equipped with integral hoods and switch-operated exhaust fans, in small residential houses, the above requirements are not applicable. Exhaust from such hoods shall be directed outdoors.

**(b) Kitchen Wet Exhaust**

See dedicated air-handling unit serving Kitchen (Food Production).

**3.10 AIR DISTRIBUTION**

**3.10.1 MANDATORY REQUIREMENTS**

**3.10.1.1 Plenum Return System**

All supply, return, exhaust, relief, and outdoor air systems shall be fully ducted between the fans and air inlets/outlets. **Use of the plenum return systems, where the space between the structural ceiling and the suspended ceiling is used to return air back to the air-handling unit, is not permitted.**

**3.10.1.2 Construction Drawings**

All ductwork, without exception and regardless of the sizes, shall be shown in double lines on floor plans and cross-sections in the final design/construction drawings.

**3.10.2 DUCTWORK**

Air distribution system shall be fabricated and installed in accordance with the applicable ASHRAE and SMACNA Standards. In the event of conflict with ASHRAE or SMACNA Standards, the parameters listed below shall govern.

**3.10.2.1 Duct Materials**

Ductwork shall be fabricated from galvanized steel, welded steel, stainless steel, or aluminum, as dictated by the specific applications. **Use of underground (galvanized or concrete) and fiberglass ductwork is not permitted.**

**3.10.2.2 Flexible Ductwork**

Use of flexible ductwork shall be limited to connections between the VAV/CV air terminal units and medium or high-pressure supply air duct and connections between the supply air diffusers and the low-pressure supply air ductwork. Additional restrictions are:

- (a) Do not use flexible duct with exposed ductwork in occupied areas.
- (b) Maximum length of flexible ductwork shall not exceed 5 ft [2 m].
- (c) Do not penetrate firewalls with flexible ducts.

**3.10.2.3 Minimum Duct Size**

**Rectangular Duct**

8 in [200 mm] x 6 in [150 mm]

**Round Duct**

6 in [150 mm]

**3.10.2.4 Duct Sizing Criteria**

Use the equal friction method for sizing low-velocity ductwork. Use the static regain method for sizing medium velocity ductwork. See Table 3.1 below for the limiting parameters. Both limiting parameters (maximum velocity and maximum static pressure drop) must be simultaneously satisfied.



Table 3-1 DUCT SIZING CRITERIA		
Duct Description	Maximum Air Velocity	Maximum Static Pressure Drop
Low Pressure Duct <ul style="list-style-type: none"> <li>• Supply</li> <li>• Return</li> <li>• Relief</li> <li>• Exhaust</li> </ul>	1,500 fpm [8 m/s]	0.08 in WG/100 ft [0.66 Pa/m]
Medium/High Pressure Duct <ul style="list-style-type: none"> <li>• Supply</li> </ul>	2,500 fpm [13 m/s]	0.2 in WG/100 ft [1.64 Pa/m]
Return Air Transfer Duct	750 fpm [4 m/s]	0.04 in WG/100 ft [0.33 Pa/m]

**3.10.2.5 Duct Pressure Classification**

Show duct pressure requirements for all ductwork on the floor plans. Required duct classification shall be shown as 2 in, 3 in, and 4 in [500 Pa, 750 Pa, and 1000 Pa].

The mechanical designer is responsible for determining the pressure class or classes required for duct construction and for designating the classification on the contract drawings. All ducts shall be sealed to Seal Class A requirements.

**3.10.2.6 Exposed Ductwork**

All exposed (visible in space) ductwork in occupied conditioned spaces shall be designed and fabricated from non-perforated, double-wall, flat-oval, or round ductwork. Provide 1 in [25 mm] thick fiberglass insulation between the two walls. Duct painting and finish requirements shall be coordinated with the VA Authorities.

**3.10.3 AIR TERMINAL UNITS**

**3.10.3.1 General**

- (a) Provide pressure-independent, DDC-controlled air terminal units (also referred to as boxes), for constant and/or variable air volume applications. Each box shall be equipped with an integral, hot water reheat coil. Provide two-way, modulating control valves.
- (b) Design maximum and minimum air volumes shall be factory-set, but field-adjustable. The minimum setting shall meet the following requirements:
  - Make-up air for exhaust
  - Minimum ventilation needs
  - Limit the supply air temperature to 100 F [38 C] in heating mode; increase supply air volume, if required for providing more heat

**3.10.3.2 Limiting Capacities**

Maximum capacity of a single air terminal unit shall not exceed 1,200 cfm [566 L/s]. Minimum hot water flow shall not be lower than 0.5 gpm [0.03 L/s].

**3.10.3.3 Air Distribution Outlets/Inlets**

**(a) Linear Diffusers**

For entrance lobbies with a high exposed glass façade and spaces with perimeter windows requiring prevention of cold drafts and solar radiation, linear diffusers shall be used.

The minimum length of the supply air diffusers shall match the window width. The design shall include a factory-furnished, internally-insulated supply-air plenum over the diffuser. Provide a single feed or multiple feeds to the plenum, as recommended by the manufacturer, to ensure uniform velocity distribution. Provide a manual volume control damper for balancing.

**(b) Square/Rectangular Diffusers**

- (1) For interior spaces and where required, include square 24 x 24 in [600 x 600 mm] or 12 x 12 in [300 x 300 mm] supply air diffusers with neck sizes to meet the duty conditions. Provide multiple supply air diffusers to ensure uniform air distribution without dead spots.
- (2) Use rectangular diffusers with blank offs, as required, to provide uneven throw.
- (3) For corridors, provide two-way blow diffusers to suit the space geometry.
- (4) Capacity of a single supply air diffuser shall meet specified room noise criteria with static pressure drop not exceeding .08 in of WG [20 Pa] and the Air Diffusion Performance Index (ADPI) shall not be less than 0.

**(c) Round Diffusers**

Round diffusers shall be used where ductwork is exposed in occupied spaces.

**3.11 APPLICATIONS**

**3.11.1 GENERAL**

This section includes:

- HVAC design parameters for air-handling units used in all-air systems and minimum ventilation air units serving terminal heating and cooling units
- Room Data Sheets (RDS), arranged in alphabetical order

**3.11.2 AIR-HANDLING UNITS ZONING CRITERIA**

**3.11.2.1 Selecting Air-Handling Units**

Where the facilities are served by all-air systems, the HVAC system design shall be based on the selection of the air-handling units to serve similar spaces by the same air-handling units. Typical air-handling units are shown at the end of this chapter.

**3.11.2.2 Considerations**

While the selection of air-handling units shall be project-specific, the following considerations shall be used:

- Project Size and Scope
- Maximum Limiting Capacity of AHU
- Application Type
- Hours of Operation
- Physical Proximity of Areas

**3.11.2.3 Home and Community Center**

The areas covered in these adjoining and interdependent spaces shall be grouped together and served by single or multiple air-handling units.

#### 3.11.2.4 Common Spaces

The common spaces include functions that are generally served by the all-air systems. While dedicated air-handling units will be required to serve some unique functions, others can be grouped together and served by a common air-handling unit. Listed below are examples of spaces requiring dedicated air-handling units and spaces served by common air-handling units. The actual list of common spaces shall be project-specific.

##### (a) Dedicated Air-Handling Units

- Atrium
- Auditoriums and Theaters
- Gymnasium
- Kitchen (Food Production)
- Standalone Smoking Facility

##### (b) Common Air-Handling Units (Home and Community Center, Minimum Ventilation Air)

- Hair Care (Barber/Beauty)
- Chapel/Meditation
- Great Room
- Media Center

#### 3.11.2.5 Enclosed Circulation Spaces

Enclosed circulation spaces between the housing clusters can be served by air-handling units as the indoor conditions are relaxed due to transient occupancy and the air distribution and automatic control systems are not complex.

#### 3.11.2.6 All Air Systems – AHU System Data Sheets

AHU System Data Sheets for potential dedicated air-handling units are shown on the following pages.

<b>ATRIUM - AIR HANDLING UNIT</b>	
<b>AHU System Data Sheet</b>	
Air Handling Type	Constant or Variable Air Volume
Indoor Design Temperature - Cooling	75 F [24 C]
Indoor Design Temperature - Heating	70 F [21 C]
Indoor Design Relative Humidity - Dehumidification	60%
Indoor Design Relative Humidity - Humidification	20%
Minimum Total Air Changes Per Hour	4
Minimum Outdoor Air Changes Per Hour	2
Return Air Permitted	Yes (Normal Mode)
Exhaust Air Required	Yes (Smoke Evacuation Mode)
Air Economizer Cycle Required	Yes
Heat Recovery System Required	ASHRAE Standard 90.1 - 2007
Filtration - Pre-Filters (PF-1 and PF-2)	PF-1 = MERV 7 and PF-2 = MERV 11
Cooling Source	Chilled Water
Heating Source	Steam and/or Hot Water
Humidification Source	Plant or "Clean" Steam
General Exhaust System Required	No
Special Exhaust System Required	Yes (Smoke Evacuation Mode)
Emergency Power Required	Yes (Smoke Evacuation System)
Individual Room Temperature Control Required	Yes
Room Air Balance	Positive (+) (Normal Mode) Negative (-) (Smoke Evacuation)
<b>Note 1 - HVAC System</b>	
Based on Atrium configuration and air distribution arrangement, evaluate using a variable air volume HVAC system in lieu of a constant volume system.	
<b>Note 2 - Smoke Evacuation System</b>	
Design the smoke evacuation system per NFPA 101 and its associated documents. VA has opted to follow NFPA 101 with the understanding that the provisions of NFPA 101 may be at variance with the IBC. The design calculations shall be performed by a fire protection professional engineer and reviewed by an independent fire protection professional engineer. The VA fire protection engineer may serve as the independent reviewer.	
<b>Note 3 - Design Details</b>	
<b>(a)</b> Upon activation of the smoke evacuation system, the Atrium AHU shall operate in 100% outdoor air mode. Provide an additional make-up air system if the required smoke removal volume is greater than the Atrium AHU supply air volume. The make-up air system shall be complete with fan, MERV 7 filter, and a heating coil.	
<b>(b)</b> Size the heating capacity to maintain 50 F [10 C] minimum space temperature in the smoke evacuation mode. For 32 F [0 C] and lower ambient temperatures, design the heating system with freeze protection measures.	

<b>AUDITORIUMS AND THEATERS - AIR HANDLING UNIT</b>	
<b>AHU System Data Sheet</b>	
Air Handling Type	Constant or Variable Air Volume
Indoor Design Temperature - Cooling	75 F [24 C]
Indoor Design Temperature - Heating	70 F [21 C]
Indoor Design Relative Humidity - Dehumidification	60%
Indoor Design Relative Humidity - Humidification	Optional
Minimum Total Air Changes Per Hour	4
Minimum Outdoor Air Changes Per Hour	Chapter 2
Return Air Permitted	Yes
Exhaust Air Required	No
Air Economizer Cycle Required	Yes
Heat Recovery System Required	ASHRAE Standard 90.1 - 2007
Filtration - Pre-Filters (PF-1 and PF-2)	PF-1 = MERV 7 and PF-2 = MERV 11
Cooling Source	Chilled Water
Heating Source	Steam and/or Hot Water
Humidification Source	Plant or "Clean" Steam
General Exhaust System Required	Yes
Special Exhaust System Required	No
Emergency Power Required	No
Individual Room Temperature Control Required	Yes
Room Air Balance	Positive (+)
<b>Note 1 - HVAC System</b>	
Based on Auditorium and Theater air distribution arrangement and extent of conditioned air volume, evaluate using a variable air volume HVAC system in lieu of a constant volume system.	
<b>Note 2 - Demand Control Ventilation</b>	
Incorporate demand-controlled ventilation sequence, if feasible, to control outdoor air based on carbon-dioxide concentration.	
<b>Note 3 - High-Humidity Control</b>	
Incorporate high-humidity limiting control sequence to monitor and control the space relative humidity to 60% maximum. See Chapter 5 for project-specific suggested sequences.	
<b>Note 4 - General Exhaust System</b>	
Exhaust the spaces associated with the Auditorium and Theater either by a dedicated or a common exhaust system (examples: toilets, HAC, etc.).	

<b>GYMNASIUM - AIR HANDLING UNIT</b>	
<b>AHU System Data Sheet</b>	
Air Handling Type	Constant Volume
Indoor Design Temperature - Cooling	75 F [24 C]
Indoor Design Temperature - Heating	70 F [21 C]
Indoor Design Relative Humidity - Dehumidification	60%
Indoor Design Relative Humidity - Humidification	Optional
Minimum Total Air Changes Per Hour	6
Minimum Outdoor Air Changes Per Hour	Chapter 2
Return Air Permitted	Yes
Exhaust Air Required	No
Air Economizer Cycle Required	Yes
Heat Recovery System Required	ASHRAE Standard 90.1 - 2008
Filtration - Pre-Filters (PF-1 and PF-2)	PF-1 = MERV 7 and PF-2 = MERV 11
Cooling Source	Chilled Water or DX
Heating Source	Steam and/or Hot Water
Humidification Source	Plant or "Clean" Steam
General Exhaust System Required	Yes
Special Exhaust System Required	No
Emergency Power Required	No
Individual Room Temperature Control Required	Yes
Room Air Balance	Neutral (o)
<b>Note 1 - Demand-Controlled Ventilation</b>	
Incorporate demand-controlled ventilation sequence, if feasible, to control outdoor air based on carbon-dioxide concentration.	
<b>Note 2 - General Exhaust System</b>	
Provide a general exhaust system to serve adjoining support spaces (examples: toilets, locker rooms, HAC, etc.).	

**HOME AND COMMUNITY CENTER - AIR HANDLING UNIT**

**AHU System Data Sheet**

Air Handling Type	Variable Air Volume
Indoor Design Temperature - Cooling	Room Data Sheets
Indoor Design Temperature - Heating	Room Data Sheets
Indoor Design Relative Humidity - Dehumidification	Room Data Sheets
Indoor Design Relative Humidity - Humidification	Room Data Sheets
Minimum Total Air Changes Per Hour	Room Data Sheets
Minimum Outdoor Air Changes Per Hour	Chapter 2
Return Air Permitted	Yes
Exhaust Air Required	No
Air Economizer Cycle Required	Yes
Heat Recovery System Required	ASHRAE Standard 90.1 - 2007
Filtration - Pre-Filters (PF-1 and PF-2)	PF-1 = MERV 7 and PF-2 = MERV 11
Cooling Source	Chilled Water
Heating Source	Steam and/or Hot Water
Humidification Source	Plant or "Clean" Steam
General Exhaust System Required	Yes
Special Exhaust System Required	Room Data Sheets
Emergency Power Required	Yes
Individual Room Temperature Control Required	Room Data Sheets

**Note 1 - VAV Air-Handling Units**

The all-air VAV system describe here can also be used for applicable spaces such as offices, lobbies, classrooms, examination rooms, conference rooms, etc.

<b>KITCHEN (FOOD PRODUCTION) - AIR HANDLING UNIT</b>	
<b>AHU System Data Sheet</b>	
Air Handling Type	Constant Volume
Indoor Design Temperature - Cooling	78 F [26 C]
Indoor Design Temperature - Heating	70 F [21 C]
Indoor Design Relative Humidity - Dehumidification	60%
Indoor Design Relative Humidity - Humidification	Not Required
Minimum Total Air Changes Per Hour	10
Minimum Outdoor Air Changes Per Hour	Chapter 2
Return Air Permitted	Yes
Exhaust Air Required	Yes
Air Economizer Cycle Required	Yes
Heat Recovery System Required	ASHRAE Standard 90.1 - 2007
Filtration - Pre-Filters (PF-1 and PF-2)	PF-1 = MERV 7 and PF-2 = MERV 11
Cooling Source	Chilled Water
Heating Source	Steam and/or Hot Water
Humidification Source	Not Required
General Exhaust System Required	Yes
Special Exhaust System Required	Yes
Emergency Power Required	No
Individual Room Temperature Control Required	Yes
Room Air Balance	Negative (-)
Compliance	NFPA 96
<b>Note 1 - Space Air Balance</b>	
Minimum room air changes can be increased to meet the exhaust requirements of the range hood and canopy hoods. Conversely, room air can be returned back to the air-handling unit if the system air balance shows surplus air after accounting for the hood exhaust requirement and the use of the return air is economically viable. Transfer air from the exit corridor may be used to maintain negative air balance in the space.	
<b>Note 2 - Grease Hood Exhaust System</b>	
Provide a dedicated exhaust system to remove grease-laden air in accordance with NFPA 96. The design shall also follow the following code requirements:	
<b>(a)</b> Discharge exhaust per dispersion analysis recommendations.	
<b>(b)</b> Maintain at least 40 in [1000 mm] between the roof surface and exhaust air outlet.	
<b>(c)</b> Do not install fire dampers, volume dampers, and turning vanes in the exhaust duct. Avoid excessive horizontal runs and install access doors at each turn for grease removal.	
<b>(d)</b> Do not install exhaust duct in the shaft carrying environmental ducts (NFPA 90A).	
<b>Note 3 - Make-Up Air Hood (Grease Hood Exhaust)</b>	
Make-up air hood is permitted if proven economically viable. Past experience has shown that the initial and recurring costs associated with the make-up air system and the discomfort experienced by the kitchen staff due to the proximity of marginally tempered make-up air makes the make-up air hood system as a less desirable alternate.	
<b>Note 4 - General Exhaust System (Optional)</b>	
Provide a dedicated exhaust system to capture heat over refrigeration condensing units, plate warmer, mixer, etc. Factory or field-installed installed canopy hoods may be required.	



**KITCHEN (FOOD PRODUCTION) - AIR HANDLING UNIT**

**AHU System Data Sheet**

**Note 5 - Wet Exhaust System**

Provide a dedicated exhaust system to capture and remove moisture over pot/pan washing areas, dishwashers, steam kettles, steamers and high-pressure cookers. Use field-installed or integral hoods furnished by the equipment manufacturer.

**Note 6 - Heat Recovery System or Return Air**

Based on the actual air balance and the life-cycle cost analysis, either return the "clean air" to the system or exhaust outdoors after passing through a heat recovery system. Note that the use of a heat recovery system is not permitted with grease laden and wet air exhausts.

<b>MINIMUM VENTILATION AIR - AIR HANDLING UNIT</b>	
<b>AHU System Data Sheet</b>	
Air Handling Type	Constant Volume
Indoor Design Temperature - Cooling	Not Applicable
Indoor Design Temperature - Heating	Not Applicable
Indoor Design Relative Humidity - Dehumidification	Not Applicable
Indoor Design Relative Humidity - Humidification	Not Applicable
Minimum Total Air Changes Per Hour	Not Applicable
Minimum Outdoor Air Changes Per Hour	Chapter 2
Return Air Permitted	No
Exhaust Air Required	Yes
Air Economizer Cycle Required	Not Applicable
Heat Recovery System Required	ASHRAE Standard 90.1 - 2007
Filtration - Pre-Filters (PF-1 and PF-2)	PF-1 = MERV 7 and PF-2 = MERV 11
Cooling Source	Chilled Water
Heating Source	Steam and/or Hot Water
Humidification Source	Plant or "Clean" Steam
General Exhaust System Required	Yes
Special Exhaust System Required	No
Emergency Power Required	No
Individual Room Temperature Control Required	Room Data Sheets
<b>Note 1 - Application</b>	
The minimum ventilation air unit is used when spaces are served by heating and cooling terminal units, such as, fan coil units, ground source heat pumps, etc.	
<b>Note 2 - Minimum Outdoor Air Unit</b>	
See individual Room Data Sheets for required outdoor air changes.	
<b>Note 3 - Control Strategy</b>	
See Chapter 3 for the recommended ventilation air control strategy.	

<b>STANDALONE SMOKING FACILITY - AIR HANDLING UNIT</b>	
<b>AHU System Data Sheet</b>	
Air Handling Type	Constant Volume
Indoor Design Temperature - Cooling	77 F [25 C]
Indoor Design Temperature - Heating	70 F [21 C]
Indoor Design Relative Humidity - Dehumidification	60%
Indoor Design Relative Humidity - Humidification	Not Required
Minimum Total Air Changes Per Hour	6
Minimum Outdoor Air Changes Per Hour	Chapter 2
Return Air Permitted	Yes
Exhaust Air Required	Yes (Intermittently)
Air Economizer Cycle Required	Yes
Heat Recovery System Required	ASHRAE Standard 90.1 - 2007
Filtration - Pre-Filter (PF-1)	PF 1 = MERV 7
Cooling Source	Chilled Water or DX
Heating Source	Steam and/or Hot Water, Electric
Humidification Source	Not Required
General Exhaust System Required	Yes
Special Exhaust System Required	No
Emergency Power Required	No
Individual Room Temperature Control Required	Yes
Room Air Balance	Negative (-)
<b>Note 1 - VHA Directive</b>	
Per VHA Directive (2003-035 dated July 1, 2003), smoking is permitted for long term care patients and mental health patients. Indoor smoking must not interfere with the safety of non-smokers.	
<b>Note 2 - HVAC System Details and Controls</b>	
The HVAC system selection shall be project specific - either a chilled water or direct-expansion (DX) system.	
<b>(a) Chilled Water System</b>	
Provide a modulating chilled water control valve.	
<b>(b) DX System</b>	
Provide at least two independent refrigeration circuits, if available for the required capacity.	
<b>Note 3 - Suggested Control Sequences</b>	
<b>(a) Unoccupied Mode</b>	
The system shall cycle (on/off) with the outdoor air damper closed to maintain a night-setback temperature at 60 F [16 C].	
<b>(b) Purge Cycle</b>	
A dedicated exhaust fan shall operate intermittently during occupied mode to flush smoke-laden air outdoors.	

### **3.12 ROOM DATA SHEETS**

#### **3.12.1 GENERAL**

In the following pages, HVAC requirements are given for the rooms generally required in the CLC/DOM facilities. These rooms are arranged in alphabetical order. The pages are referred to as the Room Data Sheets (RDS). The HVAC requirements are based on the assumption that these rooms shall be served by all-air system(s).

#### **3.12.2 TERMINAL HVAC SYSTEMS**

With terminal HVAC systems, such as fan coil units or the Ground Source Heat Pump (GSHP) system, the conditions specified may not be obtainable.

##### **(a) Total Air Changes per Hour**

With terminal systems, there is no specific number of supply air changes per hour. The supply air volume shall be based on the capacity of the selected terminal unit.

##### **(b) Noise Levels**

With terminal systems, the actual noise levels shall be higher than the expected noise levels specified in the RDS. The terminal units shall be designed to operate at low or mid-speed to deliver the required capacity.

##### **(c) Air Flow**

With terminal systems, the airflow shall remain constant, as variable air volume operation is not feasible.

COMMUNITY CENTER - ROOM DATA SHEET														
ROOM NAME	INDOOR TEMPERATURE			INDOOR RELATIVE HUMIDITY			MIN TOTAL ACH	MIN OA ACH	ROOM AIR		MAX NOISE LEVEL NC	ROOM AIR BALANCE	INDIVIDUAL ROOM CONTROL	
	COOLING		HEATING	% RH	% RH	RETURN			EXHAUST (G)	EXHAUST (S)			TEMP	FLOW
	F	C	F	C	MAX	MIN								
<b>Bistro</b>	75	24	70	21	60	20	4	2	2	Return	40	(-)	Yes	VAV
<b>Note - None</b>														
<b>Chapel/Meditation</b>	75	24	70	21	60	20	4	2	2	Return	35	(o)	Yes	VAV
<b>Note 1 - Energy Conservation Initiative</b> Provide a carbon-dioxide (CO <sub>2</sub> ) and/or occupancy sensor to conserve energy during light occupancy. The control sequence shall be project-specific.														
<b>Note - None</b>														
<b>Concierge Station</b>	75	24	70	21	60	20	4	2	2	Return	40	(-)	Yes	VAV
<b>Note - None</b>														
<b>Conference Room</b>	75	24	70	21	60	20	4	2	2	Return	40	(o)	Yes	VAV
<b>Note 1 - Energy Conservation Initiative</b> Provide a carbon-dioxide (CO <sub>2</sub> ) and/or occupancy sensor to conserve energy during light occupancy. The control sequence shall be project-specific.														
<b>Note - None</b>														
<b>Copy Room</b>	80	27	70	21	60	NA	6	2	2	Return	40	(o)	Yes	VAV
<b>Note 1 - Room Temperature Control</b> Copy Room may not require individual room temperature control if open to an adjoining space during the occupied mode. Room air from the adjoining space can be returned over the copy equipment to reduce heat concentration.														
<b>Note - None</b>														
<b>Garage</b>	NA	NA	60	15	NA	NA	-	100%	100%	Exhaust (S)	50	(-)	Yes	CV
<b>Note 1 - Ventilation (100% Outdoor Air)</b> Provide a ventilation system complete with fan(s), exhaust and/or supply, and air inlet and outlet connections equipped with motorized dampers. Size and select the system to move air at the rate of 1.5 cfm/sf [7.6 L/s/m <sup>2</sup> ].														
<b>Note 2 - Heating</b> Provide thermostatically-controlled heat delivered either by the supply air system or individual air terminal units. During heating mode, reduce the outdoor air to minimum as mandated by ASHRAE Standard 62.1-2007 and other applicable documents.														
<b>Note 3 - Compliance and Reference</b> The HVAC system shall be in compliance with the American Council of Government Industrial Hygienists (ACGIH) and NFPA 88B. Refer to the ASHRAE Handbook of Applications for further information.														

COMMUNITY CENTER - ROOM DATA SHEET														
ROOM NAME	INDOOR TEMPERATURE			INDOOR RELATIVE HUMIDITY			MIN TOTAL ACH	MIN OA ACH	ROOM AIR		MAX NOISE LEVEL NC	ROOM AIR BALANCE	INDIVIDUAL ROOM CONTROL	
	COOLING		HEATING	% RH	% RH	RETURN			EXHAUST (G)	EXHAUST (S)			TEMP	FLOW
	F	C	F	C	MAX	MIN								
<b>Great Room</b>	75	24	70	21	60	20	6	200%	Return	40	(o)	Yes	VAV	
<b>Note 1 - Energy Conservation Initiative</b> Provide a carbon-dioxide (CO <sub>2</sub> ) and/or occupancy sensor to conserve energy during light occupancy. The control sequence shall be project-specific.														
<b>HAC</b>	NA	NA	NA	NA	NA	NA	10	NA	Exhaust (G)	40	(-)	No	CV	
<b>Note - None</b>														
<b>Hair Care (Barber/Beauty)</b>	75	24	70	21	60	20	4	2	Return	40	(-)	Yes	VAV	
<b>Note 1 - Ducted Exhaust</b> Provide ducted exhaust per ASHRAE Standard 62.1-2007.														
<b>Media Center</b>	75	24	70	21	60	20	6	2	Return	40	(o)	Yes	VAV	
<b>Note 1 - Equipment Heat Gain</b> Coordinate equipment heat gain with the equipment manufacturer.														
<b>Multi-Purpose Room</b>	75	24	70	21	60	20	4	2	Return	40	(o)	Yes	VAV	
<b>Note 1 - Folding Partitions</b> Where the room is equipped with folding partitions, provide individual room temperature control for either side of the partition.														
<b>Offices - Activities Director/ Administrators/Maintenance/Nursing</b>	75	24	70	21	60	20	4	2	Return	40	(o)	Yes	VAV	
<b>Note 1 - Individual Room Temperature Control</b> See Chapter 2 for individual room temperature control details.														
<b>Public Toilets</b>	NA	NA	68	20	NA	NA	10	NA	Exhaust (G)	40	(-)	Yes	CV	
<b>Note 1 - Terminal Heater</b> Provide a thermostatically-controlled, terminal heater for the toilets subject to heat loss.														

COMMUNITY CENTER - ROOM DATA SHEET															
ROOM NAME	INDOOR TEMPERATURE				INDOOR RELATIVE HUMIDITY			MIN TOTAL ACH	MIN OA ACH	ROOM AIR		MAX NOISE LEVEL NC	ROOM AIR BALANCE	INDIVIDUAL ROOM CONTROL	
	COOLING		HEATING		% RH	% RH	RETURN			EXHAUST (G)	TEMP			FLOW	
	F	C	F	C	MAX	MIN		EXHAUST (S)							
<b>Satellite Telephone/Communications Closet</b>	68	20	68	20	NA	NA	6	NA	40	Return	40	( o )	Yes	CV	
<b>Note 1 - General</b> The Satellite Telephone/Communication Closet (also known as Room) shall be served by a dedicated, cooling unit in operation on-demand and uninterrupted. Evaluate project-specific cooling sources, such as chilled-water fan coil units, self-contained DX units, and/or environmental air-handling unit in operation round-the-clock and year-round.															
<b>Staff Lounge and Lockers</b>	75	24	70	21	60	20	4	2	40	Exhaust (G)	40	( - )	Yes	CV	
<b>Note - None</b>															
<b>Staff Toilet</b>	NA	NA	68	20	NA	NA	10	NA	40	Exhaust (G)	40	( - - )	Yes	CV	
<b>Note 1 - Terminal Heater</b> Provide a thermostatically-controlled, terminal heater for the toilets subject to heat loss.															
<b>Note 2 - Transfer Air for Exhaust</b> For Staff Toilets located with the Staff Lounge and Lockers, provide transfer air for exhaust from the Staff Lounge and Lockers.															
<b>Storage - Multi-Purpose Room/General/Maintenance</b>	NA	NA	50	10	NA	NA	NA	NA	40	NA	40	NA	Yes	NA	
<b>Note 1 - Terminal Heater</b> Provide a thermostatically-controlled, terminal heater for a storage room subject to heat loss and possibility of fire protection and/or water pipe freezing.															
<b>Vestibule</b>	NA	NA	50	10	NA	NA	NA	NA	40	NA	40	( + )	Yes	CV	
<b>Note 1 - Heating</b> Provide a thermostatically-controlled terminal heater. Coordinate heater type and location with the architectural discipline. Floor-mounted cabinet unit heaters with bottom horizontal supply and top return have proven effective in counter-acting cold air settling at the floor level.															
<b>Note 2 - Space Pressurization</b> Supply 1.0 cfm/sf [5.1 L/s/m <sup>2</sup> ] air under positive pressure from an adjoining air terminal unit serving the lobby to maintain positive air pressure by allowing air to exfiltrate outdoors.															

COMMUNITY CENTER - MISCELLANEOUS SPACES - ROOM DATA SHEET														
ROOM NAME	INDOOR TEMPERATURE			INDOOR RELATIVE HUMIDITY			MIN TOTAL ACH	MIN OA ACH	ROOM AIR		MAX NOISE LEVEL NC	ROOM AIR BALANCE	INDIVIDUAL ROOM CONTROL	
	COOLING		HEATING	% RH	% RH	RETURN			EXHAUST (G)	Exhaust (G)			45	( o )
	F	C	F	C	MAX	MIN	NA	NA	10		10	10		
<b>Attic Space</b>	NA	NA	50	10	NA	NA	10	10	10	10	45	( o )	Yes	CV
<p><b>Note 1 - Heating System</b> Provide a thermostatically controlled (closed-loop, local control) heating system utilizing terminal unit heaters or a central heating system. Ensure uniform heat distribution. Minimum outdoor ACH is not required in heating mode. The ventilation system shall be inoperative when the heating system is enabled.</p> <p><b>Note 2 - Ventilation System</b> Provide an exhaust ventilation system (closed-loop, local control either thermostatically or manually operated) to prevent excessive heat build up. The exhaust ventilation system shall consist of exhaust fan(s) and exhaust/intake air louvers with motorized dampers. Provide direct-drive fan(s) to reduce maintenance. If a central, supply air heating system (Note 1) is the selected option, exhaust (relief) arrangement shall be compatible with the central heating system.</p> <p><b>Note 3 - Access</b> Coordinate access to the mechanical equipment with the architectural discipline.</p>														
<b>Crawl Space (Pipe Basement)</b>	NA	NA	50	10	NA	NA	6	6	6	6	45	NA	Yes	CV
<p><b>Note 1 - Compliance</b> This space shall comply with PG-18-3 (Design and Construction Procedures), Topic 5 - Pipe Basements April 2001, available in the VA Technical Information Library.</p> <p><b>Note 2 - Exhaust Ventilation System</b> Provide a thermostatically-controlled (closed-loop, local control), or manually-operated, exhaust system to minimize excessive heat build-up. The system shall consist of an exhaust fan(s), exhaust air louver, intake louver, and motorized intake and exhaust air dampers (two-position, open/close type). Select a direct-drive exhaust fan to minimize maintenance.</p> <p><b>Note 3 - Heating System</b> Provide thermostatically-controlled (closed-loop, local control) terminal heaters to ensure uniform heat distribution. The ventilation system shall be inoperative when the heating system is enabled.</p>														



COMMUNITY CENTER - MISCELLANEOUS SPACES - ROOM DATA SHEET													
ROOM NAME	INDOOR TEMPERATURE			INDOOR RELATIVE HUMIDITY			MIN OA ACH	ROOM AIR RETURN EXHAUST (G)	ROOM AIR EXHAUST (S)	MAX NOISE LEVEL NC	ROOM AIR BALANCE	INDIVIDUAL ROOM CONTROL	
	COOLING		HEATING	% RH	% RH	% RH						TEMP	FLOW
	F	C	F	C	MAX	MIN							
<b>Electrical Equipment Rooms (EER)</b>													
<b>Electrical Equipment Closets without Internal Heat Gain</b>	NA	NA	NA	NA	NA	NA	NA	NA	NA	NA	NA	NA	NA
<b>Note 1 - HVAC</b> Electrical closets without internal heat gain do not require HVAC.													
<b>Satellite and Main Electrical Rooms with Internal Heat Gain</b>	86	30	40	5	NA	NA	NA	Note 2	Return	45	(o)	Yes	CV
<b>Note 1 - Equipment Heat Gain</b> Estimate transformer heat dissipation at the rate of 3% of the anticipated actual peak demand. Do not use the rated nameplate capacity for equipment heat gain.													
<b>Note 2 - Mechanical Cooling</b>													
(a) Provide a dedicated mechanical cooling unit using chilled water or refrigerant direct expansion (DX) as the cooling medium. Cooling shall be available on demand.													
(b) Use economizer cycle (ASHRAE Standard 90.1 - 2007) or exhaust ventilation in mild weather.													
(c) Provide minimum outdoor air (ASHRAE Standard 62.1 - 2007) in the mechanical cooling mode.													
(d) Avoid installing mechanical cooling units within the electrical room to prevent possible damage due to water leakage and/or overflow of condensate drain pans.													
<b>Note 3 - Heating</b> Provide thermostatically-controlled heating system only if the space heat gain cannot offset the design heat loss.													
<b>Note 4 - Controls</b> Provide a DDC sensor to monitor the space temperature and initiate local and remote alarms in the event space temperature exceeds 95 F [35 C]. Provide a DDC sensor for monitoring and alarm with local control loop.													
<b>Exterior Stairs</b>													
<b>Note 1 - Heating</b> Provide a dedicated, thermostatically-controlled terminal heater with closed-loop, non-DDC temperature control.	NA	NA	50	10	NA	NA	NA	NA	NA	NA	NA	Yes	NA

**COMMUNITY CENTER - MISCELLANEOUS SPACES - ROOM DATA SHEET**

ROOM NAME	INDOOR TEMPERATURE			INDOOR RELATIVE HUMIDITY			MIN TOTAL ACH	MIN OA ACH	ROOM AIR		MAX NOISE LEVEL NC	ROOM AIR BALANCE	INDIVIDUAL ROOM CONTROL	
	COOLING		HEATING	% RH	% RH	RETURN			EXHAUST (G)	TEMP			FLOW	
	F	C	F	C	MAX	MIN	EXHAUST (S)							

**Mechanical Equipment Rooms (MER)**

<b>Air Handling Equipment Rooms</b>	84	29	50	10	NA	NA	6	2	Return	45	( o )	Yes	CV
-------------------------------------	----	----	----	----	----	----	---	---	--------	----	-------	-----	----

**Note 1 - HVAC (All Locations)**  
 Provide a dedicated supply air takeoff (from the air-handling unit located in the MER) to circulate conditioned air at 0.5 cfm/sf [2.5 L/s/m<sup>2</sup>]. Circulated air can be returned back to the unit. Thermostatically-controlled terminal heater may be required to maintain the winter set point, where the AHU is not in operation round-the-clock.

<b>Heating Rooms</b>	86	30	40	5	NA	NA	6	2	Return	45	( o )	Yes	CV
----------------------	----	----	----	---	----	----	---	---	--------	----	-------	-----	----

**Note 1 - Heating Rooms**  
 Heating Rooms are the designated mechanical equipment rooms where steam enters the building for space heating, domestic hot water production, process heating, etc. The Heating Room is equipped with heat exchangers, PRV stations, circulating pumps, and other steam and hot water specialties.

**Note 2 - High Humidity Locations**  
**(a) HVAC Systems**  
 Provide mechanical cooling, during peak summer season, by a thermostatically-controlled, dedicated chilled water or direct-expansion (DX) unit. The room can also be served by a thermostatically-controlled, air terminal unit from a nearby air-handling unit in operation round-the-clock.

**(b) Heating Requirement**  
 Verify the need for heating. Generally heating is not required as the heat produced within the space is sufficient enough to maintain above freezing temperatures.

**Note 3 - All Other Locations**  
**(a) Ventilation Option**  
 For low-humidity (dry) locations, in mild weather, exhaust and/or supply air ventilation system can be used to keep the space temperature below 86 F [30 C]. The system shall consist of fans, inlet and outlet connections with motorized dampers, ductwork, and thermostatic controls. If using this option, increase minimum total ACH to 10.

**(b) Mechanical Cooling**  
 Provide mechanical cooling, during peak summer season, by a thermostatically-controlled, dedicated chilled water or DX unit. The room can also be served by a thermostatically-controlled, air terminal unit from a nearby air-handling unit in operation round-the-clock.

**(c) Heating**  
 Verify the need for heating. Generally heating is not required as the heat produced within the space is sufficient enough to maintain above freezing temperatures.

COMMUNITY CENTER - MISCELLANEOUS SPACES - ROOM DATA SHEET														
ROOM NAME	INDOOR TEMPERATURE			INDOOR RELATIVE HUMIDITY			MIN TOTAL ACH	MIN OA ACH	ROOM AIR		MAX NOISE LEVEL NC	ROOM AIR BALANCE	INDIVIDUAL ROOM CONTROL	
	COOLING		HEATING	% RH	% RH	RETURN			EXHAUST (G)	EXHAUST (S)			TEMP	FLOW
	F	C	F	C	MAX	MIN	ACH	ACH	Return	( o )	Yes	CV		
Refrigeration Equipment Rooms	86	30	40	5	NA	NA	6	NA	Return	45	( o )	Yes	CV	
<p><b>Note 1 - High Humidity Locations</b>  <b>(a) General</b>            Provide a dedicated mechanical cooling unit, complete chilled water or direct-expansion (DX) coil and minimum MERV 7 filters. Provide minimum outdoor air per ASHRAE Standard 15 (latest version) and capability to operate at 100% outdoor air during emergency refrigerant evacuation mode. Provide a variable speed drive to facilitate system operation in the normal and emergency modes.</p> <p><b>(b) Capacity - Mechanical Cooling Unit</b>            Base the capacity on the maximum of:            Internal heat gain (note that the heat dissipated by open chillers is much higher than hermetic chillers) or            Exhaust air volume required to dilute a refrigerant spill - see ASHRAE Standard 15.</p> <p><b>Note 2 - All Other Locations</b>            Provide an exhaust ventilation system or a dedicated air-handling system, generally as described under Note 1, and equipped with an economizer cycle, if feasible. Evaporative cooling can be used, in lieu of mechanical cooling, for low humidity locations.</p> <p><b>Note 3 - Emergency Refrigerant Leak Evacuation System</b>            Provide a refrigerant leak detection system complete with field-installed refrigerant detection sensors, wiring and local control panel per ASHRAE Standard 15. Provide an open protocol BACnet interface with the building ECC system. Provide local alarms per ASHRAE Standard 15 requirements. Provide remote alarms at the ECC.</p> <p><b>Note 4 - Emergency Exhaust System</b>            Upon activation by the leak detection system, the room air shall be exhausted outdoors by an emergency exhaust system and supply air system shall operate in 100% outdoor air mode. Provide exhaust air inlets in accordance with the recommendations of ASHRAE Standard 15 and chiller manufacturer. Activation of the leak detection system shall also trigger local and remote alarms. Provide emergency power for the emergency exhaust and supply fans and associated controls.</p>														

COMMUNITY CENTER - OPTIONAL SPACES - ROOM DATA SHEET														
ROOM NAME	INDOOR TEMPERATURE			INDOOR RELATIVE HUMIDITY			MIN TOTAL ACH	MIN OA ACH	ROOM AIR		MAX NOISE LEVEL NC	ROOM AIR BALANCE	INDIVIDUAL ROOM CONTROL	
	COOLING		HEATING	% RH	% RH	RETURN			EXHAUST (G)	EXHAUST (S)			TEMP	FLOW
	F	C	F	C	MAX	MIN								
<b>Examination Room</b>	75	24	70	21	60	20	4	2	Return	35	(o)	Yes	VAV	
<b>Note 1 - Individual Room Temperature Control</b> See Chapter 2 for individual room temperature requirements.														
<b>Pharmacy</b>	75	24	70	21	60	20	4	2	Return	35	(o)	Yes	VAV	
<b>Note - None</b>														
<b>Physician Office</b>	75	24	70	21	60	20	4	2	Return	35	(o)	Yes	VAV	
<b>Note 1 - Individual Room Temperature Control</b> Required for a single office. Otherwise see Chapter 2 for individual room temperature requirements.														
<b>Receiving/Loading</b>	75	24	70	21	60	NA	4	2	Return	40	(+)	Yes	VAV	
<b>Note 1 - Air Curtain</b> Provide an air curtain with a heating element. Interlock the air curtain start sequence with the loading door dock operating mechanism. Activate heating when the ambient temperature drops below 45 F [7 C].														
<b>Security Office</b>	75	24	70	21	60	NA	4	2	Return	35	(o)	Yes	VAV	
<b>Note 1 - Individual Room Temperature Control</b> Required for a single office. Otherwise see Chapter 2 for individual room temperature details.														

HOME - ROOM DATA SHEET													
ROOM NAME	INDOOR TEMPERATURE			INDOOR RELATIVE HUMIDITY			MIN TOTAL ACH	ROOM AIR RETURN EXHAUST (G)	MAX NOISE LEVEL NC	ROOM AIR BALANCE	INDIVIDUAL ROOM CONTROL		
	COOLING		HEATING	% RH	% RH	% RH					TEMP	FLOW	
	F	C	F	C	MAX	MIN	ACH	EXHAUST (S)	NC	(-)	Yes	CV	
<b>Bathing Suite</b>	75	24	82	28	60	NA	10	2	Exhaust (S)	40	(-)	Yes	CV
<p><b>Note 1 - General</b> This room connects to an adjacent toilet.</p> <p><b>Note 2 - Special Exhaust System</b> Provide a dedicated wet-exhaust system to serve the Bathing Suite, including the connected toilet.</p> <p><b>Note 3 - Air Balance</b> Maintain Bathing Suite at negative air balance with respect to the adjoining spaces and the toilet at negative air balance with respect to the Bathing Suite. Exhaust toilet with transfer air drawn from the Bathing Suite.</p>													
<b>Bedroom - Resident</b>	75	24	70	21	60	20	4	2	Return	35	(o)	Yes	VAV
<p><b>Note - None</b></p>													
<b>Bedroom - Special Care Resident</b>	75	24	70	21	60	20	4	2	Return	35	(o)	Yes	VAV
<p><b>Note - None</b></p>													
<b>Clean Linen Closet</b>	NA	NA	NA	NA	NA	NA	4	NA	Return	40	(+)	No	CV
<p><b>Note 1 - Storage Type</b> Two different configurations of the clean linen closet are described.</p> <p><b>Note 2 - Small Closet</b> For small, unoccupied closet (60 sf to 80 sf [6 m<sup>2</sup> to 7 m<sup>2</sup>] size) supply conditioned air under positive air pressure but do not provide room temperature control and ducted return air. Allow air to ex-filtrate to the adjoining space to maintain positive air balance.</p> <p><b>Note 3 - Large Storage Closet</b> For large occupied storage closet (greater than 80 sf [7 m<sup>2</sup>]) provide a dedicated air terminal unit with room temperature control and ducted return air. Balance supply and return air flows to maintain positive air balance.</p>													

HOME - ROOM DATA SHEET															
ROOM NAME	INDOOR TEMPERATURE				INDOOR RELATIVE HUMIDITY			MIN TOTAL ACH	MIN OA ACH	ROOM AIR		MAX NOISE LEVEL NC	ROOM AIR BALANCE	INDIVIDUAL ROOM CONTROL	
	COOLING		HEATING		% RH	% RH	RETURN			EXHAUST (G)	EXHAUST (S)			TEMP	FLOW
	F	C	F	C	MAX	MIN									
Corridor	75	24	70	21	60	20	4	2	2	Return	40	(+)	Yes	VAV	
<b>Note - 1 General</b> The HVAC data is applicable to all corridors (circulation spaces) in the CLC/DOM.															
<b>Note - 2 Supply Air Volume</b> Adjust supply air volume as required to meet the transfer air demand of the adjoining spaces, such as, toilets, HACs and/or soiled utility rooms requiring negative air balance and exterior doors requiring ex-filtration.															
Den	75	24	70	21	60	20	4	2	2	Return	35	(o)	Yes	VAV	
<b>Note - None</b>															
Dining Room	75	24	70	21	60	20	4	2	2	Return	35	(o)	Yes	VAV	
<b>Note - None</b>															
Foyer	NA	NA	NA	NA	NA	NA	4	NA	NA	Return	35	(o)	No	VAV	
<b>Note 1 - General</b> Since Foyer is part of a bedroom, individual room temperature control is not required.															
Garage	NA	NA	50	10	NA	NA	NA	NA	NA	Return	35	(o)	Yes	CV	
<b>Note 1 - General</b> Provide a thermostatically-controlled heater for colder climates (40 F [5 C] and below) when the Garage is equipped with fire protection or water piping.															
HAC	NA	NA	NA	NA	NA	NA	10	NA	NA	Exhaust (G)	40	(-)	No	CV	
<b>Note - None</b>															
Hair Care (Barber/Beauty)	75	24	70	21	60	20	4	2	2	Return	40	(-)	Yes	VAV	
<b>Note 1 - Ducted Exhaust</b> Provide ducted exhaust per ASHRAE Standard 62.1-2007.															

HOME - ROOM DATA SHEET															
ROOM NAME	INDOOR TEMPERATURE				INDOOR RELATIVE HUMIDITY			MIN TOTAL ACH	MIN OA ACH	ROOM AIR		MAX NOISE LEVEL NC	ROOM AIR BALANCE	INDIVIDUAL ROOM CONTROL	
	COOLING		HEATING		% RH	% RH	RETURN			EXHAUST (G)	EXHAUST (S)			TEMP	FLOW
	F	C	F	C	MAX	MIN									
Home Entry/Front Porch	75	24	70	21	60	20	4	2	2	Return	35	(o)	No	VAV	
<b>Note 1 - General</b> Provide HVAC in the porch if enclosed.															
Home Office	75	24	70	21	60	NA	4	2	2	Return	35	(o)	Yes	VAV	
<b>Note - None</b>															
Home Storage	NA	NA	NA	NA	NA	NA	NA	NA	NA	NA	NA	NA	NA	NA	
<b>Note 1 - General</b> This is a small closet and does not require HVAC.															
Kitchen and Pantry	75	24	70	21	60	NA	6	2	2	Exhaust (G)	40	(-)	Yes	CV	
<b>Note 1 - General</b> Space includes a pantry not requiring HVAC. <b>Note 2 - Exhaust (Range Hood)</b> Coordinate the exhaust hood requirement with the hood manufacturer. If the hood design entails 100% exhaust to outdoors, evaluate the need to comply with NFPA 96 with a dedicated exhaust system. Provide alternate return air with a motorized damper, interlocked with the hood exhaust fan. During unoccupied mode, exhaust at least 2 air changes per hour by the general exhaust system.															
Kitchen Housekeeping Closet	NA	NA	NA	NA	NA	NA	10	NA	NA	Exhaust (G)	40	(--)	No	CV	
<b>Note - None</b>															
Laundry	78	26	70	21	60	NA	10	2	2	Exhaust (G)	45	(-)	Yes	CV	
<b>Note 1 - Exhaust</b> Coordinate dryer vent exhaust with the selected equipment.															
Living Room	75	24	70	21	60	20	4	2	2	Return	40	(o)	Yes	VAV	
<b>Note 1 - Unoccupied Mode</b> Provide a project-specific unoccupied control sequence to reduce or stop the HVAC during unoccupied hours.															

HOME - ROOM DATA SHEET															
ROOM NAME	INDOOR TEMPERATURE				INDOOR RELATIVE HUMIDITY			MIN TOTAL ACH	MIN OA ACH	ROOM AIR		MAX NOISE LEVEL NC	ROOM AIR BALANCE	INDIVIDUAL ROOM CONTROL	
	COOLING		HEATING		% RH	% RH	RETURN EXHAUST (G)			EXHAUST (S)	TEMP			FLOW	
	F	C	F	C	MAX	MIN									
Soiled Utility Room	NA	NA	NA	NA	NA	NA	NA	10	NA	Exhaust (G)	40	(--)	No	CV	
<b>Note - None</b>															
Toilet - Public	NA	NA	70	21	NA	NA	NA	10	NA	Exhaust (G)	40	(--)	Yes	CV	
<b>Note - None</b>															
Toilet - Special Care Resident	NA	NA	70	21	NA	NA	NA	10	NA	Exhaust (G)	40	(--)	Yes	CV	
<b>Note 1 - Terminal Heating</b> For bathrooms subject to heat loss, provide a dedicated, thermostatically-controlled terminal heating unit to maintain set point.															
<b>Note 2 - Transfer Air</b> Air from the Special Care Resident Bedroom shall be used as transfer air for the Bathroom exhaust.															
<b>Note 1 - Terminal Heating</b> For bathrooms subject to heat loss, provide a dedicated, thermostatically-controlled terminal heating unit to maintain set point.															
<b>Note 2 - Transfer Air</b> Air from the Resident Bedroom shall be used as transfer air for the Bathroom exhaust.															



# HVAC DESIGN MANUAL

CHAPTER 3

FIGURE 3-1

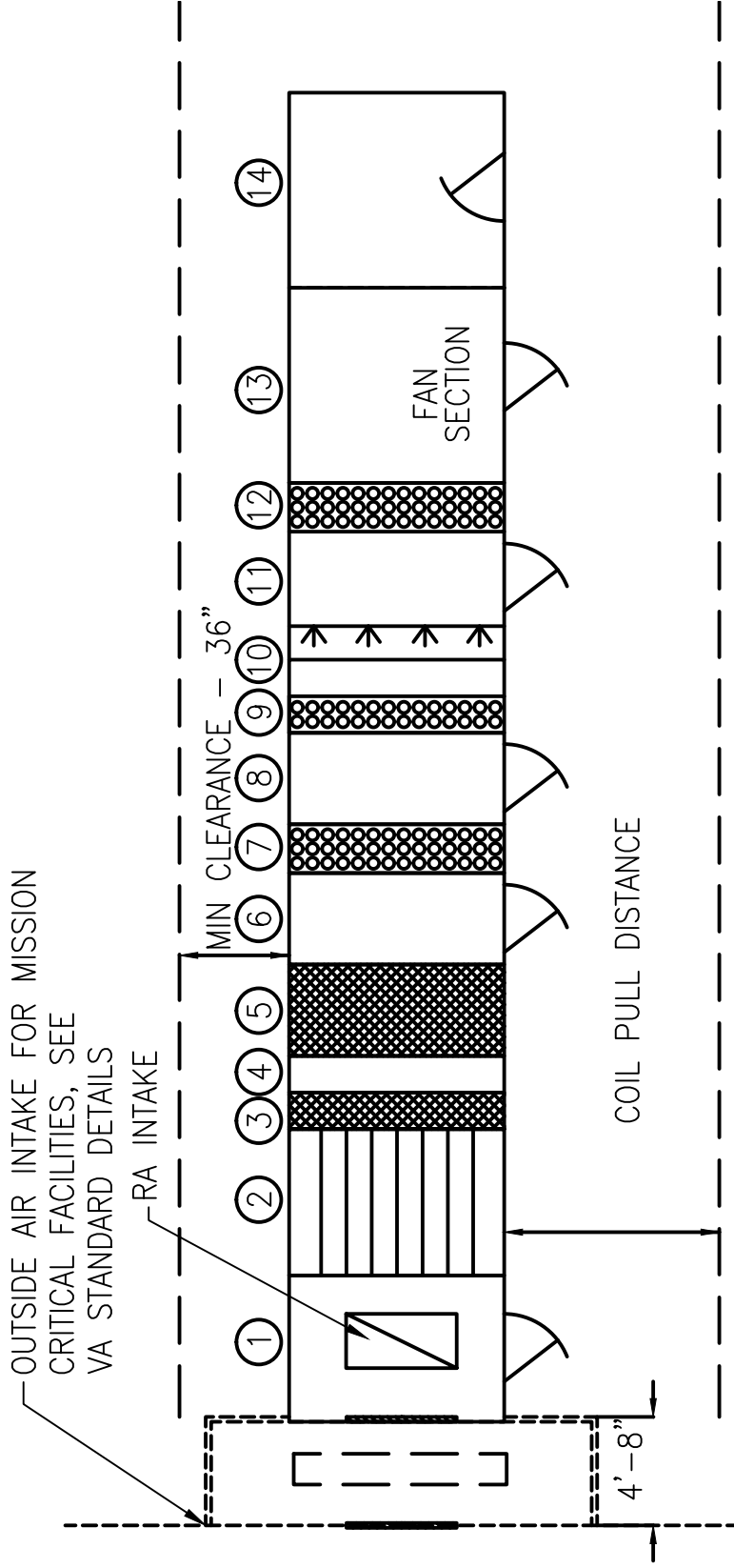

NOTE: SEE FIG. 3-1 CONTINUATION FOR GENERAL NOTES AND DIMENSIONS OF COMPONENTS

## TYPICAL AIR HANDLING UNIT

Not to Scale

# HVAC DESIGN MANUAL

## CHAPTER 3

FIGURE 3-1 (CONTINUATION)

AIR HANDLING UNIT	Item #	MINIMUM OUTSIDE AIR TWO BEDS OF FILTERS VAV	100% OUTSIDE AIR TWO BEDS OF FILTERS CV	LENGTH IN [CM]				
				20,000 CFM [9,435 L/S]	30,000 CFM [14,150 L/S]	40,000 CFM [18,870 L/S]	50,000 CFM [23,597 L/S]	
* AS REQUIRED								
Mixing Box *	1	Yes	No	48 [122]	48 [122]	49 [125]	54 [137]	
Blender Section *	2	Yes	No	48 [122]	48 [122]	49 [125]	54 [137]	
Pre-Filter (Side Access)	3	Yes	Yes	12 [30]	15 [38]	15 [38]	15 [38]	
Inspection Section, small	4	Yes	Yes	12 [30]	15 [38]	15 [38]	15 [38]	
Pre-Filter (Side Access)	5	Yes	Yes	30 [76]	30 [76]	30 [76]	30 [76]	
Access Section, med-large	6	Yes	Yes	30 [76]	30 [76]	30 [76]	30 [76]	
Heat Recovery Coil *	7	No	Yes	16 [41]	20 [51]	20 [51]	20 [51]	
Access Section, med-large *	8	No	Yes	30 [76]	30 [76]	30 [76]	30 [76]	
Pre-Heat Coil	9	Yes	Yes	12 [30]	15 [38]	15 [38]	15 [38]	
Inspection Section, small	10	Yes	Yes	12 [30]	15 [38]	15 [38]	15 [38]	
Humidifier *	11	Yes	Yes	32 [81]	40 [102]	40 [102]	40 [102]	
Cooling Coil	12	Yes	Yes	16 [41]	20 [51]	20 [51]	20 [51]	
Fan	13	Yes	Yes	64 [163]	69 [175]	84 [213]	92 [234]	
Discharge Plenum *	14	Yes	Yes	64 [163]	64 [163]	64 [163]	64 [163]	
		20,000 CFM [9,435 L/S]		30,000 CFM [14,150 L/S]	40,000 CFM [18,870 L/S]	50,000 CFM [23,597 L/S]		
Overall Width (IN [CM])	96 [244]	120 [305]		137 [348]		137 [348]		
Overall Height (IN [CM])	64 [163]	75 [191]		92 [234]		107 [272]		

**NOTES:**

- IF ITEMS 1 AND 2 ARE NOT INCLUDED, PROVIDE MED-LARGE ACCESS SECTION.
- IF SPACE IS AVAILABLE, PROVIDE ACCESS DOORS ON BOTH SIDES OF AHU. IF SPACE IS NOT AVAILABLE, ENSURE EQUIPMENT IS SERVICEABLE FROM ONE SIDE OF THE AHU.
- HUMIDIFIER LOCATION IS OPTIONAL AND MAY BE LOCATED IN THE AHU OR IN THE MAIN SUPPLY AIR DUCT.
- SEE VA STANDARD DETAILS FOR OUTSIDE AIR PLENUM DETAIL. THE PLENUM LENGTH IS APPROXIMATELY 4'-8" [1.42M].
- THE INFORMATION GIVEN IN THE DETAIL IS FOR CONCEPTUAL DESIGN AND PLANNING. THE DESIGNER SHALL MAKE HIS OWN SELECTION BASED ON ENGINEERING CALCULATIONS AND UNIT BASIS OF DESIGN.

### TYPICAL AIR HANDLING UNIT

Not to Scale

**CHAPTER 4: BUILDING COOLING AND HEATING SYSTEMS**

Table of Contents

4.1	INTRODUCTION .....	4-2
4.2	COOLING SYSTEMS .....	4-2
4.2.1	CENTRAL CHILLED WATER PLANTS .....	4-2
4.2.2	DEDICATED CHILLED WATER SYSTEMS .....	4-2
4.2.2.1	General.....	4-2
4.2.2.2	Air-Cooled Chillers.....	4-2
4.2.2.3	Standby Capacity Requirement .....	4-2
4.2.2.4	Refrigerant.....	4-3
4.2.2.5	Physical Security Requirements .....	4-3
4.2.2.6	Chiller Performance .....	4-3
4.2.2.7	Miscellaneous Requirements.....	4-3
4.2.2.8	Chilled Water Piping/Pumping Configuration .....	4-4
4.2.2.9	Chilled Water Distribution System – Primary-Secondary System (PSS).....	4-4
4.2.2.10	Chilled Water Distribution System – Variable Primary System (VPS).....	4-4
4.2.2.11	Single Chiller Systems (Constant and Variable Volume).....	4-5
4.2.3	CHILLED WATER SYSTEM COMPONENTS.....	4-5
4.2.3.1	Pump Types .....	4-5
4.2.3.2	Pump Selection.....	4-5
4.2.3.3	Cooling Towers.....	4-6
4.2.3.4	Water Treatment – Chilled Water System.....	4-6
4.2.3.5	Water Treatment – Condenser Water System .....	4-6
4.2.3.6	Glycol – Chilled Water Systems.....	4-7
4.2.4	DIRECT EXPANSION (DX) SYSTEMS .....	4-7
4.2.4.1	Self-Contained Terminal Units .....	4-7
4.2.5	DIRECT EXPANSION (DX) VAV SYSTEMS – ROOFTOP UNITS.....	4-7
4.3	HEATING SYSTEMS.....	4-8
4.3.1	STEAM HEATING SYSTEMS.....	4-8
4.3.1.1	General.....	4-8
4.3.1.2	Standby Capacity.....	4-8
4.3.1.3	Steam System Specialties and Piping.....	4-8
4.3.2	HYDRONIC HEATING SYSTEMS.....	4-8
4.3.2.1	Boilers – General .....	4-8
4.3.2.2	Boiler Selection Criteria .....	4-9
4.3.2.3	Hot Water Piping and Pumping.....	4-9
4.3.2.4	Hot Water Terminal Units.....	4-9
4.3.2.5	Freeze Protection – Hot Water.....	4-9
4.3.3	ELECTRICAL HEATING SYSTEMS.....	4-10
4.3.3.1	General.....	4-10
4.3.3.2	Applications .....	4-10
4.3.3.3	Controls .....	4-10
4.3.4	GAS HEATING SYSTEMS .....	4-10
4.3.4.1	General.....	4-10
4.3.4.2	Applications .....	4-10
4.3.4.3	Heating Equipment .....	4-10
4.3.4.4	Miscellaneous Items .....	4-10
4.3.5	GEOHERMAL HEATING SYSTEMS.....	4-11
4.3.5.1	General.....	4-11
4.3.5.2	References .....	4-11
4.3.5.3	Analysis .....	4-11
4.4	PIPING .....	4-11

4.4.1	DESIGN CRITERIA – WATER PIPING.....	4-11
4.4.1.1	Minimum Pipe Size .....	4-11
4.4.1.2	Drains and Vents .....	4-11
4.4.1.3	Dielectric Fitting .....	4-11
4.4.1.4	Water Pipe Sizing .....	4-12
4.4.2	DESIGN CRITERIA – STEAM PIPING .....	4-12
4.4.2.1	General.....	4-12
4.4.2.2	Pressure Classification .....	4-12
4.4.2.3	Steam Pipe Sizing .....	4-12
4.4.2.4	Steam Pressure Requirements .....	4-13
4.4.2.5	Pressure Reducing Valve (PRV) Stations .....	4-13
4.4.2.6	Miscellaneous Design Requirements .....	4-13
APPENDIX 4A: PROPYLENE GLYCOL – WATER SOLUTION.....		4A-1
4A.1	GENERAL .....	4A-1
4A.1.1	SELECTION CRITERIA.....	4A-1
4A.1.2	COIL FREEZE PROTECTION .....	4A-1
4A.1.3	PROPYLENE GLYCOL PROPERTIES.....	4A-2
4A.2	PUMP SELECTION .....	4A-3
4A.2.1	STEP 1: EQUIPMENT FLOW RATE AND HEAD .....	4A-3
4A.2.2	STEP 2: HEAD CORRECTION DUE TO VISCOSITY.....	4A-3
4A.2.3	STEP 3: POWER CORRECTION DUE TO VISCOSITY .....	4A-3
4A.2.4	SAMPLE PUMP SELECTION – WITH PROPYLENE GLYCOL SOLUTION.....	4A-4
4A.3	NOTES TO BE ADDED TO EQUIPMENT SCHEDULES.....	4A-6

## 4.1 INTRODUCTION

This chapter describes mechanical cooling and heating systems to meet the needs of the Community Living Center, Domiciliary, and associated support functions, collectively referred to as the Facilities in this document. Information given below should be used in conjunction with VA Standard Details, Master Specifications, and associated documents, described in [Chapter 1](#) and located in the TIL.

## 4.2 COOLING SYSTEMS

In this chapter, the following systems are described:

- Central Chilled Water Plants
- Dedicated Chilled Water Systems
- Chilled Water System Components
- Direct Expansion (DX) Systems
- Direct Expansion (DX) VAV Systems – Rooftop Units (not recommended)

### 4.2.1 CENTRAL CHILLED WATER PLANTS

Where the facilities are located within the Medical Center Complex, use of the existing central chilled water plant and the distribution loop is the preferred option to meet the cooling needs. The A/E shall thoroughly investigate the existing central plant in consultation with VA Engineering Department and provide recommendations. The investigation shall include:

- Chilled Water Availability – Year Around or Seasonal
- Available Spare Capacity
- Feasibility to Extend the Distribution Loop
- Chilled Water Temperature
- System Hydraulics

New central chilled water plants are generally not covered in the scope of CLC/DOM projects.

### 4.2.2 DEDICATED CHILLED WATER SYSTEMS

#### 4.2.2.1 General

Provide a dedicated chilled water system, when chilled water is not available from an existing central plant. Use of air-cooled chillers within the capacity limitations outlined below is preferred to ensure water conservation, absence of water treatment and chemicals, and ease of installation with quick start during mild weather.

Provide two chillers of 50% capacity each to meet the cooling demand.

#### 4.2.2.2 Air-Cooled Chillers

(a) Capacity of a single air-cooled chiller shall not exceed 250 tons of refrigeration at AHRI conditions.

(b) Use water-cooled chillers when the total cooling load demand exceeds 400 tons of refrigeration.

#### 4.2.2.3 Standby Capacity Requirement

Provide N+1 chillers for the locations where ASHRAE 1% cooling dry-bulb temperature is greater than 85 F [30 C] and the peak cooling requirement is greater than 400 tons of refrigeration. Refer to ASHRAE Standard 170-2008 for additional requirements.

**4.2.2.4 Refrigerant**

Use of R-22 refrigerant is not permitted. Selection shall be based on R-134a or approved substitute of R-22. With water-cooled centrifugal chillers, use of R-123 is permitted until year 2020, per current EPA guidelines.

**4.2.2.5 Physical Security Requirements**

Maintain at least 33 ft [10 m] distance between chillers located on grade and the facility it serves.

**4.2.2.6 Chiller Performance**

Select chillers to be in compliance with the following criteria:

Table 4-1 Water Chilling Packages– Minimum Efficiency Air-Cooled, Electrically Operated Based on FEMP Requirements				
Equipment Type	Capacity (Tons of Refrigeration)	Minimum Efficiency Full Load (kW/Ton)	Minimum Efficiency IPLV (kW/Ton)	Test Procedure
Scroll	30 - 60	1.23	.86	AHRI 550/590
Screw	70 - 200	1.23	.98	AHRI 550/590

Table 4-2 Water Chilling Packages– Minimum Efficiency Water-Cooled, Electrically Operated Based on FEMP Requirements				
Equipment Type	Capacity (Tons of Refrigeration)	Minimum Efficiency Full Load (kW/Ton)	Minimum Efficiency IPLV (kW/Ton)	Test Procedure
Rotary Screw	150 - 299	.64	.49	AHRI 550/590
	300 and larger	.64	.49	
Centrifugal	150 - 299	.59	.52	AHRI 550/590
	300 - 2,000	.56	.45	

**4.2.2.7 Miscellaneous Requirements**

**(a) Acoustic Requirements**

For noise-sensitive locations, include the chiller manufacturer’s standard acoustic options in the design.

**(b) Corrosion Control**

For corrosive environments, include factory-applied anti-corrosion coating for the condenser coil fins.

**(c) Controls**

Provide microprocessor-based safety and operating controls. Provide native BACnet, open protocol devices and software, as required to ensure seamless integration with the central Engineering Control System (ECC).

#### **4.2.2.8 Chilled Water Piping/Pumping Configuration**

#### **4.2.2.9 Chilled Water Distribution System – Primary-Secondary System (PSS)**

##### **(a) General**

See Figure 4-1 for piping and pumping arrangement. Arrange piping and pumping in order to isolate a chiller and its associated auxiliary equipment (chilled water and condenser water pumps and cooling tower) while ensuring that the leaving chilled water temperature remains unchanged.

##### **(b) Primary Loop**

Design a constant-volume, primary loop with a dedicated pump for each chiller. Design the chilled water supply and return headers to enable the use of any pump with any chiller. Include a two-way modulating control-valve and a flow meter in each chiller circuit to isolate the idle chiller when not in operation and keep constant flow through each evaporator when one or more chillers are in use.

##### **(c) De-Coupler Piping**

Provide hydronic separation (de-coupler piping) between the primary and secondary loops to separate the two circuits and enable the chilled water flow to change direction.

##### **(d) Secondary Loop**

Provide secondary pumping loop with multiple pumps. Provide two-way modulating control valves in the secondary circuit for the cooling terminal devices. Provide a high-accuracy flow meter in the secondary circuit. Secondary pumps shall be equipped with variable speed drives. The secondary system is a variable flow system.

##### **(e) Control Strategy**

Provide a control sequence to vary the speed of the secondary chilled water pumps in response to part-load condition. Modulate the pump speed based on control valve position.

Accomplish loading, unloading, and sequencing of chillers and associated auxiliaries in response to prevailing load and accumulated run time. Include devices such as chilled water temperature sensors in the primary and secondary supply and return piping, and a flow meter in the primary supply or return piping to develop a control strategy.

Integrate the microprocessor-based chiller controls with the chilled water control system. All microprocessor-based control points shall be accessible from the ECC. Include hardware and software in the control sequence to prevent reduction in the secondary flow below a pre-determined limit.

#### **4.2.2.10 Chilled Water Distribution System – Variable Primary System (VPS)**

##### **(a) General**

See Figure 4-2 for the piping and pumping arrangement. The initial capital cost of a VPS is less and the energy efficiency greater, when compared to a primary/secondary system. However, the use of the VPS is not suitable for all applications. While VA encourages VPS use, inherent complexities of the system controls, start-up, and loading/unloading of the chillers must be resolved during design development. It is also important to ensure that a minimum constant cooling load is always available for the VPS to be effective.

##### **(b) System Operation**

Provide a common chilled water circulation/distribution loop to circulate water through the terminal cooling units and the chiller evaporators. Allow chilled water flow to vary throughout the loop, including in the evaporator tubes. Maintain minimum flow, above the manufacturer's recommended water velocity, through the evaporator tubes. A bypass assembly, similar to the PSS system, shall be included in the design as shown in Figure 4-2.

### **(c) Control Strategy**

Include a high-accuracy flow meter to monitor chilled water flow in the system design. The pump speed shall decrease in response to part-load conditions, using a similar concept as used for the PSS systems. Modulate the pump speed on control valve position.

Control the sequencing of the connected load to avoid sudden variations and not compromise the system stability. Start-stop of all air-handling units shall be programmed and software controlled.

Accomplish loading, unloading, and sequencing of chillers and associated auxiliaries in response to the prevailing load and accumulated run time. Include devices such as chilled water temperature sensors in the primary supply and return piping and a flow meter in the primary supply or return piping to develop a control strategy.

### **4.2.2.11 Single Chiller Systems (Constant and Variable Volume)**

#### **(a) General**

See Figure 4-3 for the piping and pumping arrangement. For small chiller plants consisting of one chiller (and one standby chiller), provide a constant volume system with constant speed pumps and three-way valves at the air-handling units.

#### **(b) Minimum System Volume**

To avoid frequent cycling of the chillers, the systems shall be designed to ensure that the manufacturer's recommended water volume is available. Provide an in-line water storage tank, if required, to meet this requirement. If used, the chilled water piping and storage tank shall be sized for the current installation, plus future installed chillers, if phased installation is planned.

#### **(c) Enhanced Controls Strategy**

For a single chiller installation with chilled water pump horsepower of 7.5 hp [5.6 kW] or less, provide a combination of three-way and two-way modulating chilled control valves to permit the pump to ride its curve without dead-heading. If cost-effective, evaluate the use of the variable primary system (VPS) to meet the energy reduction mandate.

## **4.2.3 CHILLED WATER SYSTEM COMPONENTS**

### **4.2.3.1 Pump Types**

Provide base-mounted, centrifugal or vertical turbine type pumps. In general, pumps smaller than 5.0 hp [3.7 kW] can be selected as in-line centrifugal pumps. For the condenser water system, ensure that the available net positive suction head (NPSH) is greater than the required NPSH to avoid unstable operation.

### **4.2.3.2 Pump Selection**

For pumps with 1,200 gpm [76 L/s] and higher capacities, optimize the pump selection. Make a selection based on efficiency, cost, and maintenance needs. Select pumps at or near the maximum efficiency point and to the left-hand side of the maximum efficiency point, but not more than 5% from the maximum efficiency curve. Limit the pump speed to 1,750 rpm. Pumps with lower speeds can be selected if found cost-effective.

Pump motors shall be non-overloading over the entire range of operation and shall be compatible with variable speed drives, where used.



#### **4.2.3.3 Cooling Towers**

##### **(a) Cooling Tower Types**

Cooling towers shall be induced draft-type, gravity-flow, factory-fabricated, and factory-tested. The cooling towers shall meet the VA Physical Security Manual requirements and be certified by the Cooling Tower Institute (CTI), and in compliance with the OSHA requirements for safety. Provide a variable speed drive for the cooling tower fan motor. The fan motor shall be located outside the airstream of the cooling tower by using fan shaft extensions.

##### **(b) Cooling Tower Selection Criteria**

Cooling tower selection shall address and resolve such issues as corrosion, noise, and height restriction. See [Chapter 2](#) for acoustic treatment. See Figure 4-4 for the piping and pumping arrangement.

##### **(c) Cooling Tower Selection Criteria and Accessories**

Each cooling tower selection shall address and resolve such issues as:

- Cooling Tower Location
- Cross Flow or Counter Flow Towers
- Gear-Drive or Belt-Drive
- Concrete Basin or Steel Basin (provide stainless steel basins for corrosion control)
- Tower Accessories – Fill, Walking Platform
- Stairs and Ladder Safety Cage
- Tower Loading and Supporting Structure
- Net Positive Suction Head Requirements
- Tower Controls
- Basin Heating

##### **(d) Coordination**

For roof-mounted cooling towers, coordinate the cooling tower loading and support design with the structural discipline. Raise the cooling tower by at least 4 ft [1.2 m] above the roof surface to facilitate access and re-roofing underneath the cooling tower.

#### **4.2.3.4 Water Treatment – Chilled Water System**

##### **(a) Chemical Shot Feeder**

Provide a chemical shot feeder in bypass position to treat the closed-loop chilled water system. Select the feeder size and chemicals based on the system volume and the water analysis, but not less than 3% of the chilled water flow rate.

##### **(b) Water Filter**

Provide a cartridge-type filter in bypass position to remove suspended solid particles from the chilled water system. Filter capacity shall be at least 3% of the chilled water flow rate. Include the bypass flow in the pump performance criteria.

#### **4.2.3.5 Water Treatment – Condenser Water System**

##### **(a) General**

Using a water sample from the site, design a water treatment system for treating the cooling tower water. Use non-toxic, FDA-approved chemicals. The water treatment system shall operate automatically using a chemical controller to monitor chemical levels, activate chemical pumps and/or valves, and actuate the blow down valve. Make-up water shall be controlled using float valve assembly.

**(b) System Description**

Provide a chemical feed pump for each chemical feed tank: scale/corrosion inhibitor and acid. Provide automatic valves for each biocide tank. Each pump or valve system shall be equipped with a check valve and drain connections. Provide double containment for acid tanks. Provide a chemical feed controller, conductivity probe, and pH and oxidation-reduction potential (ORP) sensors.

**(c) Water Meters**

Provide a water meter in the condenser water make-up line, capable of reading the actual instantaneous flow and totalized flow locally and at the remote ECC. Coordinate metering requirement with the ongoing metering project, if any, at the facility.

**(d) Floor Space**

Show the space allocated for the water treatment system on the floor plans. Include an eyewash, an emergency shower, and a washbasin. Provide a desk with storage cabinets to house the water treatment chemicals.

**(e) Solid Separator**

Include a solid separator in the condenser water circuit to eliminate suspended solid particles from the system.

**4.2.3.6 Glycol – Chilled Water Systems**

**(a) General**

Use of glycol shall be avoided as an anti-freeze measure, as doing so contradicts the mandated goal of increased energy conservation. Specifically, use of glycol:

- Reduces the heat transfer efficiency of the chillers and cooling coils
- Increases the pumping horsepower and energy consumption due to increased viscosity
- Increases recurring maintenance due to periodic loss of glycol concentration
- Increases initial capital costs due to purchase of glycol, pumping kit, and larger chilled water pumps

**(b) Suggested Project-Specific Measures – Alternate to Glycol**

- (1) Increase insulation thickness and density of exposed chilled water piping insulation by at least 1 in [25 mm] over the recommended thickness for indoor applications.
- (2) Provide thermostatically actuated heat tracing by selecting a cable of appropriate density (W/lin ft). Connect heat-tracing circuit to emergency power.
- (3) Provide a control sequence to start the pumps and keep chilled water in circulation below 32 F [0 C] ambient temperature.
- (4) Provide a storage tank to automatically drain and store the exposed chilled water volume. Locate tank in covered and heated space.

**4.2.4 DIRECT EXPANSION (DX) SYSTEMS**

**4.2.4.1 Self-Contained Terminal Units**

Use of self-contained terminal air-conditioners and heat pumps (through the wall or windows) is not permitted unless specifically approved by VA Authorities for remote and isolated spaces, such as a security station.

**4.2.5 DIRECT EXPANSION (DX) VAV SYSTEMS – ROOFTOP UNITS**

**(a) General**

Use of DX VAV systems is not permitted as the performance and reliability does not match those of available comparable air-cooled chillers with rotary compressors.

### **(b) Performance**

Modulating control required to maintain fixed supply air temperature is not available with scroll-type refrigerant compressors equipped with packaged units. Scroll compressors provide only step control, which results in a temperature swing of 3 F to 4 F [1.7 C to 2.2 C] in the supply air temperature during stable conditions. The immediate temperature swing is even higher.

### **(c) Reliability and Replacement Cost**

The life span of scroll compressors becomes limited (7 to 14 years) when the actual operating conditions are more taxing than the standard AHRI conditions. Loss of cooling capacity occurs with higher ambient air temperature on the condenser coil and lower wet-bulb air temperature on the DX evaporator coil. Based on the information provided by the manufacturers, the life-cycle replacement cost of scroll compressors equipped in DX systems can be double that of the air-cooled chillers equipped with rotary screw compressors.

## **4.3 HEATING SYSTEMS**

In this chapter, the following systems are described:

- Steam Heating Systems
- Hydronic Heating Systems
- Electrical Heating Systems
- Gas Heating Systems
- Geothermal Heating Systems

### **4.3.1 STEAM HEATING SYSTEMS**

#### **4.3.1.1 General**

Where steam is available from the existing central boiler plant, it shall be used to produce hot water by a steam-to-hot-water heat exchanger. Steam is not directly used for heating the space, with the exception of steam unit heaters.

#### **4.3.1.2 Standby Capacity**

- (a)** Provide at least two heat exchangers, each with 100% capacity, matching circulating pump, and interconnecting piping to make two independent heating systems. One system shall act as 100% standby.
- (b)** For large installations, where multiple heat exchangers are used, provide N+1 heating circuits with 1 circuit acting as standby, as mandated by ASHRAE Standard 170-2008, for facilities with 99% heating design dry-bulb temperature of 25 F [- 4 C] and below. The standby capacity shall include a heat exchanger, circulating pump, and interconnecting piping, to form a complete operating system.

#### **4.3.1.3 Steam System Specialties and Piping**

See Piping Section, this chapter.

### **4.3.2 HYDRONIC HEATING SYSTEMS**

#### **4.3.2.1 Boilers – General**

Provide packaged, hot water heating boilers to meet the heating needs of the facility. Selection of the boiler type, hot water temperature, fuel, and pumping/piping system configuration shall be based on the project requirements. To meet the mandated goal of 30% energy conservation above the ASHRAE Standard 90.1 – 2007, the heating system shall use high-efficiency condensing boilers. The boiler

selection shall be optimized to obtain high efficiency at low return water temperature. At 120 F [49 C] return water temperature, the condensing boiler efficiency is 91%.

### 4.3.2.2 Boiler Selection Criteria

#### (a) Heating Load (2,700,000 Btuh [790 kW] and Less)

Provide two boilers, 100% capacity each, complete with pump, piping, controls, etc., to make a complete working system.

#### (b) Heating Load (Higher than 2,700,000 Btuh [790 kW])

Provide three boilers, 50% capacity each, complete with pumps, piping, controls, etc., to make a complete working system. Selection of multiple boilers shall be limited to four plus one (N + 1) boilers.

#### (c) High-Efficiency Non-Condensing Boilers

Use of non-condensing boilers shall be investigated only when the capacity requirements cannot be met by an array of five (N + 1) condensing boilers.

#### (d) Fuel Selection

When natural gas is used as the primary fuel, the design shall include stored fuel (propane gas or Number 2 oil) as back-up fuel.

With condensing boilers, during interruption of natural gas, propane gas is a "natural" substitute for automatic or manual changeover. Back-up fuel is not required where natural gas is not available.

### 4.3.2.3 Hot Water Piping and Pumping

The piping and pumping configuration shall be similar to the chilled water piping and pumping configurations described in this manual.

### 4.3.2.4 Hot Water Terminal Units

- Hot Water Coils (VAV/CV) Terminal Units
- Unit Heaters
- Cabinet Unit Heaters
- Radiant Ceiling Panels
- Duct-Mounted Reheat Coils
- AHU-Mounted Preheat and Reheat Coils
- Fan Coil Units
- Convectors
- Base-Board Heaters
- Finned Tube Radiation
- Heating Hot Water Air Curtains

### 4.3.2.5 Freeze Protection – Hot Water

#### (a) General

For hot water preheat coils coming in contact with ambient air or mixed air below freezing temperatures, provide freeze protection by mixing propylene glycol in the heating hot water. Provide a glycol-hot water heating system with a heat exchanger, circulating pumps, and interconnecting piping.

#### (b) Glycol Properties

Select the smallest possible concentration of the glycol to produce the desired antifreeze properties. Include an inhibitor in the glycol solution to prevent corrosion. Water used in conjunction with the glycol shall be low in chloride and sulfate ions.

### **(c) HVAC Equipment Selection**

Selection of equipment utilizing glycol shall take into account the loss of efficiency, impact on the flow and pressure drop, and pump bhp.

#### **4.3.3 ELECTRICAL HEATING SYSTEMS**

##### **4.3.3.1 General**

Heating by resistance heaters is expensive and shall be considered only when fossil fuels are not available, and/or for the applications where use of any other fuels could pose a safety hazard.

##### **4.3.3.2 Applications**

Use terminal heating units (examples: unit heaters, finned-tube radiation, radiant panels) for locations such as:

- Emergency Generator Rooms
- Electrical Equipment Rooms
- Telecommunication Rooms
- Elevator Machine Rooms

##### **4.3.3.3 Controls**

The heating elements shall be controlled either in steps or by SCR (Silicon Controlled Rectifiers). Ensure safety compliance with heaters, such as high-temperature cutouts, as mandated by UL certification.

#### **4.3.4 GAS HEATING SYSTEMS**

##### **4.3.4.1 General**

Use gas heating where natural gas is readily available at the site. Alternately, Liquid Propane Gas (LPG) can be used.

##### **4.3.4.2 Applications**

Gas-fired equipment is generally used for miscellaneous heating applications. These applications are:

- Mechanical Rooms
- Storage Spaces

##### **4.3.4.3 Heating Equipment**

- Unit Heaters
- Rooftop HVAC Units
- Heating and Ventilation Units

All devices shall be thermostatically-controlled.

##### **4.3.4.4 Miscellaneous Items**

Ensure that combustion air and exhaust needs are addressed and included in the design per the manufacturer's recommendations and NFPA 54, National Fuel Gas Code. Care shall be taken to avoid any possibility of the vent exhaust short-circuiting into an outdoor air intake or operable windows of the occupied spaces. Follow the recommendations of the dispersion analysis. Wherever available and feasible, use modulating burners to provide energy-efficient and smooth temperature control.

### 4.3.5 GEOTHERMAL HEATING SYSTEMS

#### 4.3.5.1 General

Geothermal heating is the direct use of geothermal power for heating applications. Thermal efficiency is high because energy conversion is not needed, but capacity factors tend to be low (approximately 20%) since the heat is mostly needed in the winter. Geothermal energy originates from the heat retained within the Earth's core, from radioactive decay of minerals, and from solar energy absorbed at the surface. Most high temperature geothermal heat is harvested in regions close to tectonic plate boundaries where volcanic activity rises close to the surface of the Earth. In these areas, ground and groundwater can be found with temperatures higher than the target temperature of the application.

#### 4.3.5.2 References

The State of Idaho website ([http://www.energy.idaho.gov/renewableenergy/district\\_heating.shtml](http://www.energy.idaho.gov/renewableenergy/district_heating.shtml)) has useful design information for review.

#### 4.3.5.3 Analysis

The designer shall analyze the potential of using geothermal heating. If other facilities in the area are using geothermal energy, the designer shall prepare a life-cycle analysis with geothermal heat as an option.

### 4.4 PIPING

The design criteria given below apply to chilled water, hot water, steam and condensate piping, and drain and vent piping.

#### 4.4.1 DESIGN CRITERIA – WATER PIPING

##### 4.4.1.1 Minimum Pipe Size

For closed-loop piping systems, the minimum pipe size shall be 3/4 in [18 mm].

##### 4.4.1.2 Drains and Vents

Provide drain connections at all low points and manual air vents at all high points. Where automatic air vents are provided, a drain connection is required. Extend the drain pipe to the nearest floor drain.

##### 4.4.1.3 Dielectric Fitting

Provide a dielectric fitting to connect two dissimilar metals.

**4.4.1.4 Water Pipe Sizing**

The limiting parameters of velocity and pressure drop shall be simultaneously satisfied.

<b>Table 4-3 Water Pipe Sizing Criteria</b>		
<b>Pipe Type and Size</b>	<b>Maximum Fluid Velocity</b>	<b>Maximum Pressure Drop</b>
Chilled Water Hot Water Hot Glycol Water 2 in [50 mm] and below	6.0 fps [1.8 m/s]	2.0 ft WG/100 ft [0.2 kPa/m]
Chilled Water Hot Water Hot Glycol Water Above 2 in [50 mm]	10.0 fps [3.0 m/s]	2.0 ft WG/100 ft [0.2 kPa/m]
Condenser Water Any Size	10.0 fps [3.0 m/s]	2.0 ft WG/100 ft [0.2 kPa/m]

**Note:** For closed-loop hydronic systems, pipe sizing is based on "Cameron Hydraulic Data" with C = 150.  
For open-loop hydronic systems (condenser water), pipe sizing is based on "Cameron Hydraulic Data" with C=100.

**4.4.2 DESIGN CRITERIA – STEAM PIPING**

**4.4.2.1 General**

Wherever possible, use steam from the existing boiler plant to generate heating hot water for applications, such as kitchen service and humidification.

Obtain accurate steam pressure data from the VA Medical Center in peak and off seasons to size steam pressure reducing valve stations.

**4.4.2.2 Pressure Classification**

Follow the steam pressure classification given below:

- Low-Pressure Steam (LPS) – 15 psig [103 kPa] and below
- Medium-Pressure Steam (MPS) – 16 psig [110 kPa] through 59 psig [407 kPa]
- High-Pressure Steam (HPS) – 60 psig [414 kPa] and above

**4.4.2.3 Steam Pipe Sizing**

The limiting parameters of velocity and pressure drop shall be simultaneously satisfied.

<b>Table 4-4 Pipe Sizing Criteria</b>		
<b>Pipe Type and Size</b>	<b>Maximum Fluid Velocity</b>	<b>Maximum Pressure Drop</b>
High Pressure Steam Any Size	10,000 fpm [50 m/s]	2.0 psig/100 ft [.5 kPa/m]
Low Pressure Steam Any Size	5000 fpm [25 m/s]	0.5 psig/100 ft [.1 kPa/m]
Pumped Condensate Any Size	10.0 fps [3 m/s]	4.0 ft WG/100 ft [0.4 kPa/m]

4.4.2.4 Steam Pressure Requirements

Table 4-5 Steam Pressure Requirements	
Equipment	Operating Steam Pressure psig [kPa]
Radiators	5 [34]
Convectors	5 [34]
Heating Coils	30 [206]
Steam-to-Hot Water Converters	30 [206]
Unit Heaters	30 [206]
AHU Mounted Steam Humidifiers	30 [206]
Dietetic Equipment	Refer to Program Guide PG-18-6

4.4.2.5 Pressure Reducing Valve (PRV) Stations

- (a) Provide dedicated PRV station(s) for each building. The PRV station shall be configured for downstream pressure setpoint control.
- (b) Do not provide two-stage PRV stations to reduce high-pressure steam pressure.
- (c) Provide two PRVs in parallel at the locations and applications where significant (> 2/3) variation in the steam load is expected. Select two PRV stations of uneven sizes, the smaller valve (one-third maximum load) and larger valve (2/3 maximum load), with the smaller valve set at a higher exit pressure than the setpoint exit pressure and the larger valve set at a lower exit pressure. The smaller valve shall open first, maintaining higher than the setpoint pressure and delivering 1/3-steam flow rate. With the increase in load, the controlled pressure shall drop and the larger valve shall open, eventually admitting the remaining 2/3 steam flow rate. With the smaller valve already delivering 1/3 capacity, the total capacity shall be the full rated capacity.
- (d) Size the PRV bypass valve and the safety valve according to National Board Inspection Code of the National Board of Boiler and Pressure Vessel Inspectors (Columbus, Ohio). The safety relief valve shall be sized for the maximum flow of the largest PRV or the bypass, whichever is greater. Verify that the bypass valve capacity does not exceed the capacity of the safety valve.

4.4.2.6 Miscellaneous Design Requirements

- (a) **Shutoff Valve – HPS:** Include a shutoff valve and a pressure gauge for each incoming HPS service in the mechanical equipment room. For a shutoff valve, larger than 4 in [100 mm] size, include a factory-installed, integral warm-up valve of 3/4 in [18 mm] or 1 in [25 mm] size in bypass position.
- (b) **Steam Flow Meter:** For each steam PRV station, include a steam-flow measuring meter with interface to the EEC. Provide capability to read instantaneous and total steam flow. Coordinate meter installation with the ongoing metering project at VA Facilities.
- (c) **Stress Analysis:** Perform a computerized stress analysis on the steam piping layout and show anchors, guides, and expansion loops to avoid pipe deflection and contain expansion. The intended location for all devices shall be shown in the floor plans. Submit calculations for review and approval.
- (d) **Flash Tank** To avoid flashing, the piping design shall not permit any direct connections between the high-pressure gravity return and the medium-pressure gravity return to the low-pressure gravity return lines. Provide a flash tank, where all gravity returns shall reduce pressure and temperature. From the flash tank, the low-pressure gravity return shall flow into the condensate receiver tank of the condensate return pump set. Adjust the elevation of the flash tank outlet to ensure gravity flow



into the tank of the condensate return pump set. Gravity return must **not** be lifted. The flash tank shall be shown at all applicable locations in drawings and specifications.

- (e) **Steam Reheat Coils:** Do not locate steam reheat coils above suspended ceilings of occupied areas. Problems due to trap noise, condensate return requiring pitch, trap maintenance, and ceiling height restriction are viable reasons for avoiding steam traps. Trap installation requires at least 12 in [300 mm] for static lift and 6 in [150 mm] for the dirt leg.
- (f) **Vent Line(s):** Provide an atmospheric vent line to extend above the building roof. Vent lines from the condensate tank and flash tank can be combined into a single line. The vent line from the safety valve at the PRV station shall extend above the roof to a height of 6 ft [2 m], independent of other vent lines. To avoid long safety valve discharge piping, safety valves may be located close to the terminal point, provided no shut-off valve is installed between the PRV and the safety relief valve.
- (g) **Condensate Return Pump:** Provide a duplex condensate pump, complete with a receiver, to return the liquid condensate up to boiler plant. Provide emergency power for the pumps. If the duplex condensate pump is installed in a pump pit, the starter, disconnect switch, and alternator must be located outside the pump pit. Provide an alternator to facilitate switching the pump operation.
- (h) **Steam Traps – Selection Criteria and Limitations:**
  - (1) Provide Float and Thermostatic (F&T) traps for all modulating loads such as heat exchangers, domestic hot water heaters, and modulating control valves (where used) for preheat coils and equipment with modulating loads.
  - (2) Provide minimum 12 in [300 mm] static lift for the trap operation. Space permitting, provide 18 in [450 mm] lift. Static lift should not only be shown in the steam trap installation detail, but the floor plans must emphasize the need to provide maximum available static lift. Non-compliance with this requirement has caused operational problems in many installations.
  - (3) Size all F&T traps at 1/4 psig [2 kPa] pressure drop.
  - (4) Size traps for heat exchangers and AHU preheat coils at 250% of the design load to meet the start-up needs. No single trap shall be sized for more than 5,000 lbs [2,358 kg] per hour.
  - (5) Steam traps on the steam line condensate removal points shall be inverted bucket type, with bi-metallic thermal element for air removal. Select the working pressure range suitable for the maximum line pressure.
  - (6) For steam lines in continuous operation with infrequent shut downs, drip traps shall be sized for the line radiation loss, in lbs [kg] per hour, multiplied by three. The trap pressure differential shall be approximately 80% of the line operating pressure.
  - (7) Each coil shall be individually trapped.
  - (8) Provide a steam trap schedule by assigning a unique trap number and location. Indicate the type, capacity, and pressure differential at which the trap is selected. The trap schedule shall be shown on the drawings.

**(i) Steam Gun Sets**

Provide a steam gun set, comprising steam, water, and detergent, at the following places:

- Trash or Trash Compaction Rooms
- Dietetics – Manual Cart Wash

# HVAC DESIGN MANUAL

## CHAPTER 4

FIGURE 4-1

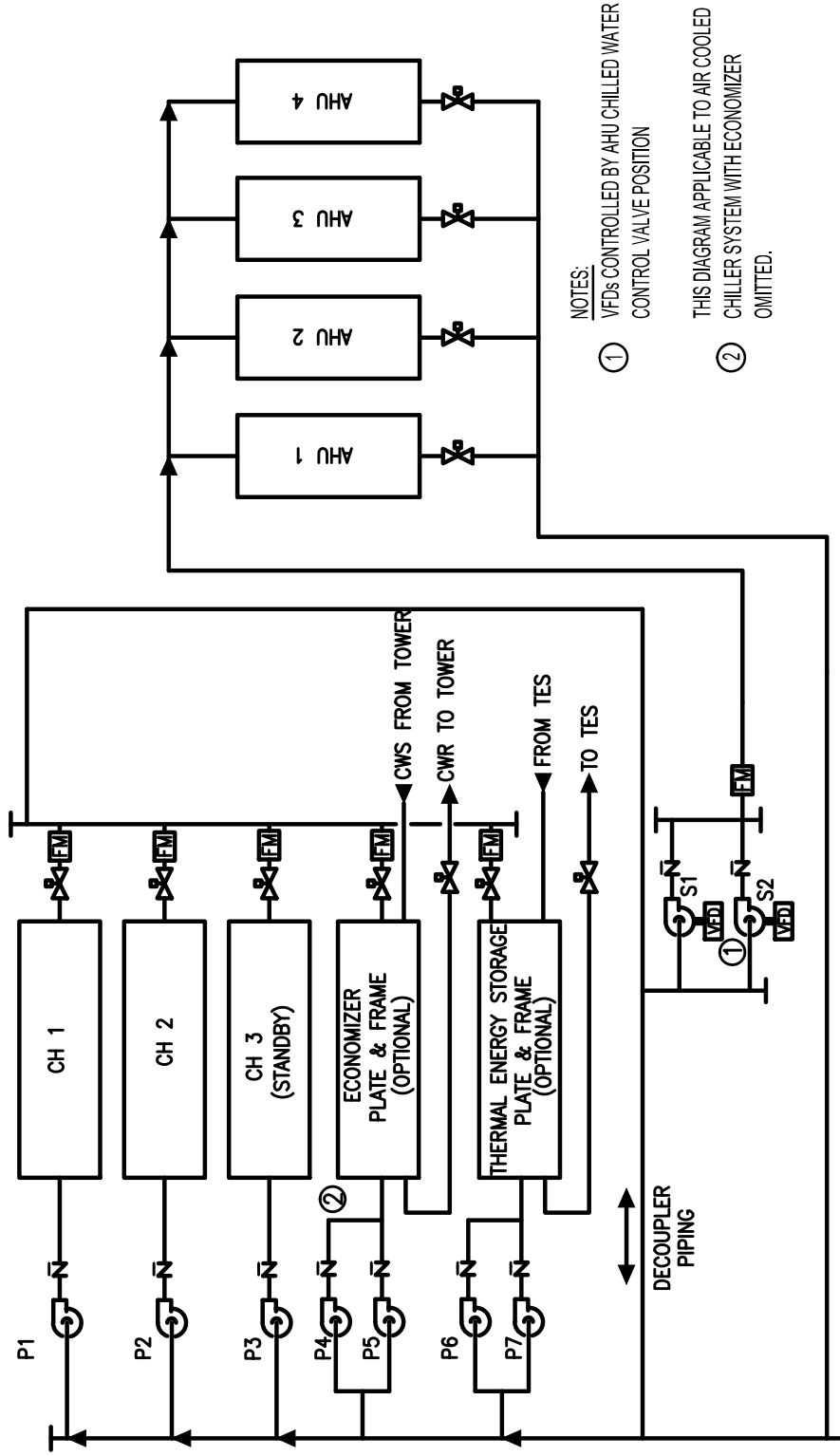

### CHILLED WATER PRODUCTION AND DISTRIBUTION - PRIMARY-SECONDARY SYSTEM (PSS)

Not to Scale

# HVAC DESIGN MANUAL

## CHAPTER 4

FIGURE 4-2

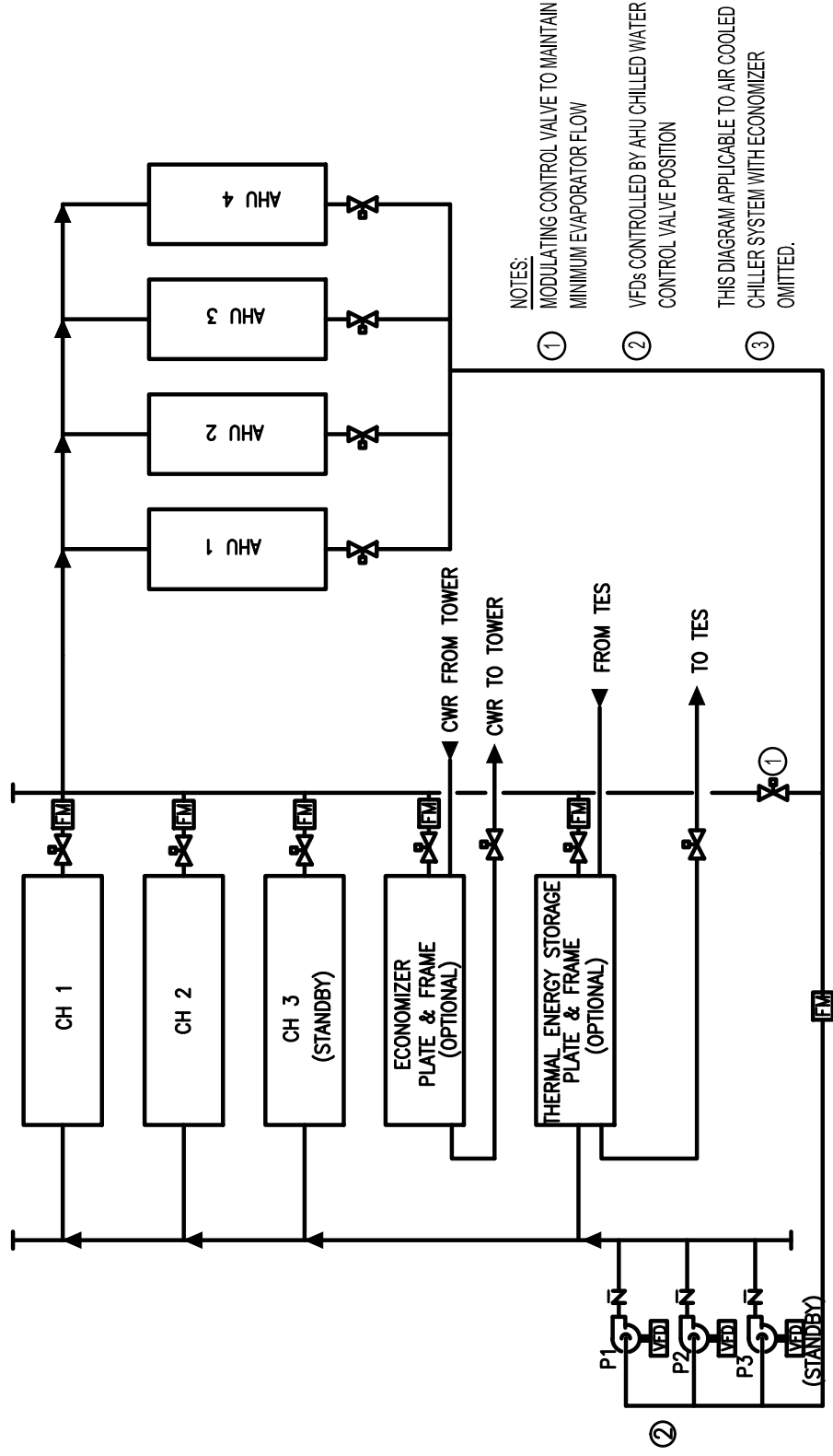

# CHILLED WATER PRODUCTION AND DISTRIBUTION - VARIABLE PRIMARY SYSTEM (VPS)

Not to Scale

# HVAC DESIGN MANUAL

## CHAPTER 4

### FIGURE 4-3

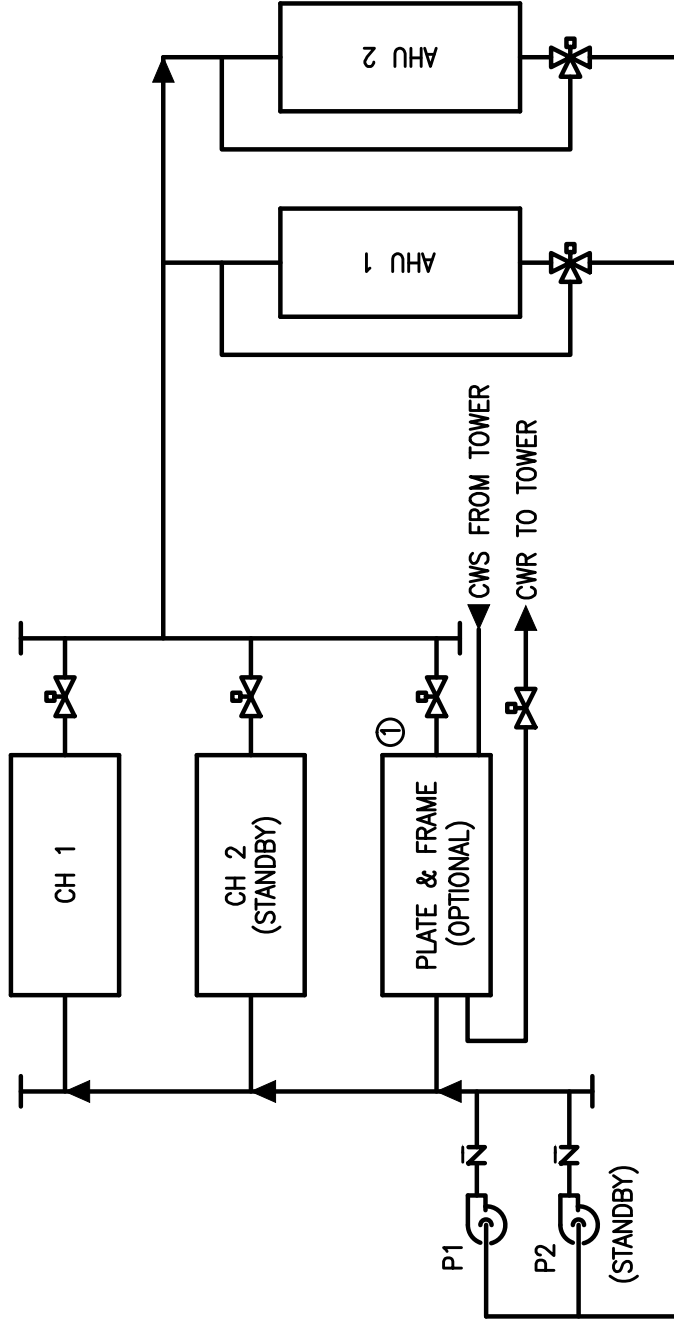

**NOTES:**

- ① THIS DIAGRAM APPLICABLE TO AIR COOLED CHILLER SYSTEM WITH ECONOMIZER OMITTED.

# CHILLED WATER PRODUCTION AND DISTRIBUTION - SINGLE CHILLER SYSTEMS, CONSTANT VOLUME

Not to Scale

# HVAC DESIGN MANUAL

CHAPTER 4

FIGURE 4-4

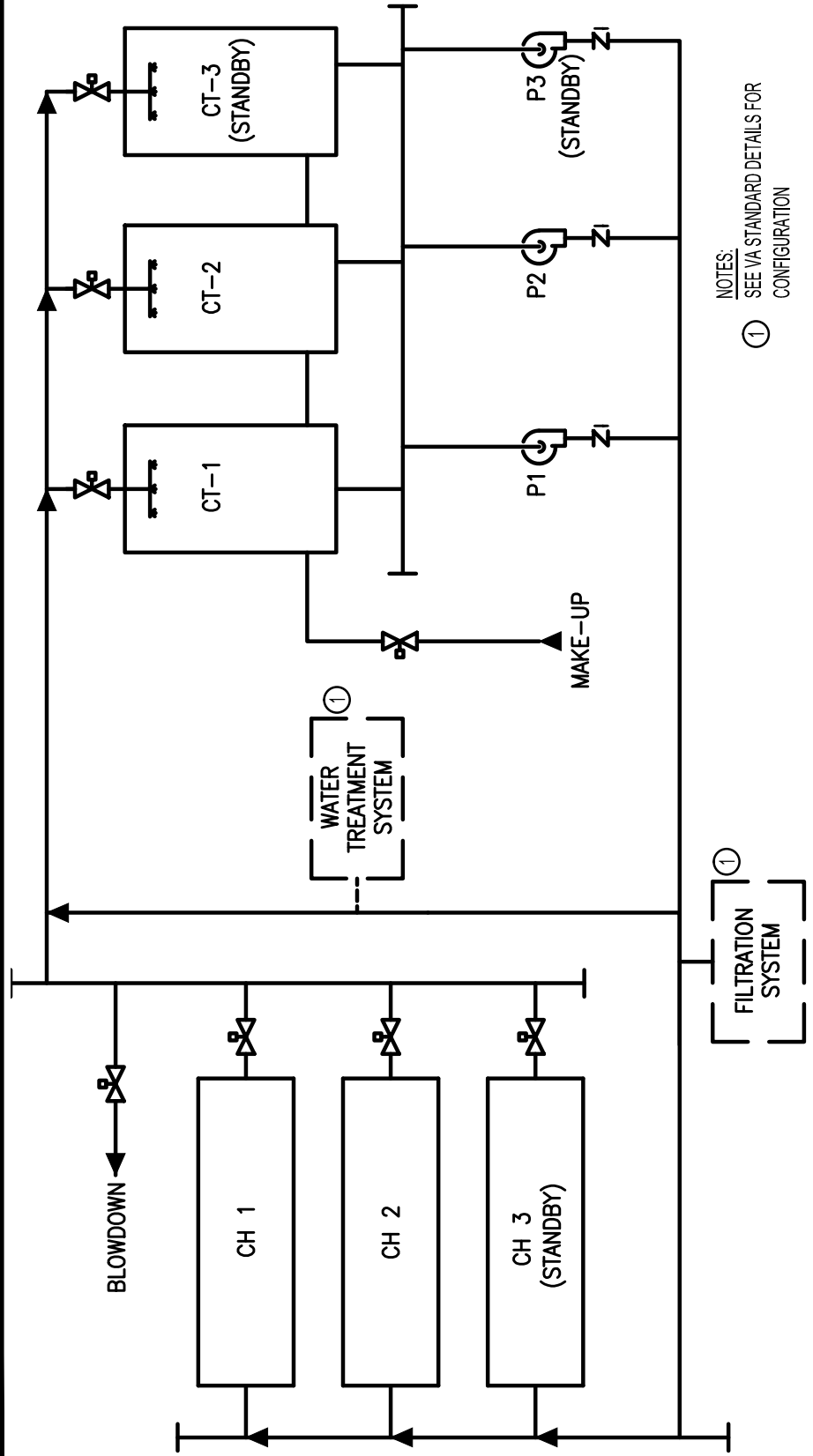

## COOLING TOWER SYSTEM

Not to Scale

## APPENDIX 4A: PROPYLENE GLYCOL – WATER SOLUTION

### 4A.1 GENERAL

All hydronic systems shall use propylene glycol solution where heat transfer applications require lower freezing temperature than water. The primary application for the addition of propylene glycol is for freeze protection.

Propylene glycol is less toxic than the commonly used ethylene glycol.

#### 4A.1.1 SELECTION CRITERIA

- (a) **Chilled Water Freeze Protection:** The freezing point of the glycol solution shall be at least 5 F [3 C] lower than the anticipated ambient temperature to prevent the formation of crystals. The anticipated ambient temperature shall be the minimum annual extreme daily temperature for the location. See [Chapter 6](#) for this temperature.
- (b) **Hot Water Freeze Protection:** The freezing point of the glycol solution shall be at least 5 F [3 C] lower than the anticipated ambient temperature to prevent the formation of crystals. The anticipated ambient temperature shall be the minimum annual extreme daily temperature for the location. See [Chapter 6](#) for this temperature.
- (c) **Thermal Energy Storage (Ice) Systems:** Consult the tank and chiller manufacturer for glycol correction sizing information and direction.
- (d) The glycol solution shall be inhibited for corrosion control.
- (e) Verify the water quality based on a site water sample to ensure compliance with the following guidelines:
- Less than 500 ppm calcium and magnesium in chemicals (chloride and sulfate)
  - Less than 25 ppm of chloride and sulfate
  - Less than 100 ppm (5 grains) of total hardness
  - Less than 100 ppm dissolved solids

Use of distilled or deionized water shall be blended with municipal water if required to meet the standards above.

#### 4A.1.2 COIL FREEZE PROTECTION

To determine the required concentration of propylene glycol, the designer shall compare the freezing temperature of the solution and the selection criteria above. The solution can be expressed by weight or volume, almost interchangeably, as the difference is negligible. The freeze point of propylene glycol is listed below:

<b>Table 4A-1 Propylene Glycol Properties (From ASHRAE Fundamentals – 2009)</b>	
<b>Percentage Concentration by Volume</b>	<b>Freezing Temperature F [C]</b>
0%	32 [0.0]
10%	26 [-3.0]
20%	19 [-7.0]
30%	9 [-13.0]
40%	-6 [-21.0]
50%	-28 [-33.0]

#### 4A.1.3 PROPYLENE GLYCOL PROPERTIES

The properties of propylene glycol are shown in the following table:

<b>Table 4A-2 Properties of Propylene Glycol Solutions (From ASHRAE Fundamentals – 2009)</b>				
<b>Percentage Concentration by Volume</b>	<b>Density* (lb/cf) [kg/m<sup>3</sup>]</b>		<b>Thermal Conductivity (Btu-ft/h-sf-F) [W/m-C]</b>	
	25-45 F	120-160 F	25-45 F	120-160 F
	[-4-7 C]	[49-71 C]	[-4-7 C]	[49-71 C]
10%	63.38 [1015]	62.28 [998]	0.293 [0.507]	0.334 [0.578]
20%	64.14 [1027]	62.85 [1007]	0.267 [0.462]	0.301 [0.521]
30%	64.79 [1038]	63.33 [1014]	0.243 [0.421]	0.270 [0.467]
40%	65.35 [1047]	63.74 [1021]	0.222 [0.384]	0.243 [0.421]
50%	65.82 [1054]	64.06 [1026]	0.201 [0.348]	0.217 [0.376]
<b>Percentage Concentration by Volume</b>	<b>Specific Heat (Btu/lb-F) [J/kg-C]</b>		<b>Viscosity (cP) [Pa-s]</b>	
	25-45 F	120-160 F	25-45 F	120-160 F
	[-4-7 C]	[49-71 C]	[-4-7 C]	[49-71 C]
10%	0.966 [4042]	0.985 [4121]	2.80 [2.80*10 <sup>-3</sup> ]	0.75 [0.75*10 <sup>-3</sup> ]
20%	0.938 [3920]	0.965 [4038]	4.23 [4.23*10 <sup>-3</sup> ]	0.97 [0.97*10 <sup>-3</sup> ]
30%	0.906 [3782]	0.939 [3929]	7.47 [7.47*10 <sup>-3</sup> ]	1.30 [1.30*10 <sup>-3</sup> ]
40%	0.868 [3623]	0.908 [3799]	13.20 [13.20*10 <sup>-3</sup> ]	1.71 [1.71*10 <sup>-3</sup> ]
50%	0.825 [3443]	0.871 [3644]	19.66 [19.66*10 <sup>-3</sup> ]	2.36 [2.36*10 <sup>-3</sup> ]

\*For pump power calculations, specific gravity is the density of propylene divided by density of water.



**4A.2 PUMP SELECTION**

**4A.2.1 STEP 1: EQUIPMENT FLOW RATE AND HEAD**

Propylene glycol, more viscous and less thermally efficient than water, requires different considerations when using standard pump selection data. Furthermore, propylene and ethylene glycol have very different properties and cannot be interchanged.

The designer shall consult the manufacturers of coils, chillers and heat exchangers to determine flow and head requirements of the equipment at the specified glycol percentage and temperature. The equipment manufacturer shall select equipment to account for specific heat, thermal conductivity and viscosity effects of the glycol solution. The designer shall coordinate with the manufacture to optimize the equipment selection to maximize the water/glycol mixture temperature differential and minimize the increase in flow rate.

**4A.2.2 STEP 2: HEAD CORRECTION DUE TO VISCOSITY**

A correction is applied to account for the increased viscosity of the propylene glycol solution. This correction factor is applied to pipe, valves and fitting pressure drop only and changes the required pump head. The manufacturer’s flow rates at the specified glycol percentage are used when determining the initial pressure drop in the piping system. The designer shall use the correction factors from Table 4A-3 when calculating the viscosity correction. The designer shall indicate the corrected values (GPM, WPD, APD, EWT, LWT) on the HVAC Equipment schedules. Provide appropriate notes.

The head correction required due to flow increases provided by the manufacturer’s equipment selection may be excessive and the designer shall evaluate increasing the pipe size to reduce the pressure drop. Maximum fluid velocity and maximum pressure drop criteria for pipe sizing shall conform to [Chapter 4](#) requirements.

Note that operating temperatures above 160 F [71 C] does not require head correction due to the effects of viscosity.

<b>Table 4A-3 Effect of Propylene Glycol Solutions (From ASHRAE HVAC Systems and Equipment – 2008)</b>		
<b>Percentage Concentration by Volume</b>	<b>Changes Due To Viscosity</b>	
	<b>Head Increase Coefficient</b>	
	<b>25-45 F [-4-7 C]</b>	<b>120-160 F [49-71 C]</b>
10%	1.08*	0.90
20%	1.14*	0.95
30%	1.27*	0.97
40%	1.45	1.00
50%	1.60	1.03

\*Used for low temperature chilled water.

**4A.2.3 STEP 3: POWER CORRECTION DUE TO VISCOSITY**

The final correction factor is applied to account for the change in pump power requirements. To find that correction, the designer shall refer to Hydraulic Institute Standard 9.6.7, *Effects of Liquid Viscosity on Rotodynamic (Centrifugal and Vertical) Pump Performance*. It is the Design Professional's responsibility to consult the standard to determine the correction factor for pump efficiency due to changes in viscosity.

#### 4A.2.4 SAMPLE PUMP SELECTION – WITH PROPYLENE GLYCOL SOLUTION

##### Application 1 – Chilled Water Freeze Protection:

A simple, all-water example follows:

A chiller and an air-handling unit chilled water coil are connected by pipe and a water-based pump operating under conditions of:

- 200 gpm [12.6 L/s]
- 70 ft [209 kPa] total head
- 40 ft [120 kPa] head due to pipe, valves and fittings
- 30 ft [90 kPa] head due to equipment
- 40 F [4 C] fluid temperature
- 5.0 bhp [3.7 kW] and 71% efficiency pump
- Specific gravity = 1.0

The equipment is a chiller and an air-handling unit chilled water coil.

Determine the operating values of the same system if the fluid is changed to a solution of 40% glycol by volume.

##### Step 1:

Manufacturers are consulted and the chilled water coil requires 300 gpm [18.9 L/s] and 22 ft [66 kPa] head and the chiller evaporator pressure drop at 300 gpm is 28 ft [84 kPa] when using 40% glycol.

##### Step 2:

Using the pump affinity laws, correct the pipe, valves, and fittings head for the new flow rate. At 300 gpm, the new head is 90 ft [269 kPa].

Total Dynamic Head Correction (due to viscosity increase) = 90 x 1.45 = 131 ft of water [390 kPa].

##### Resultant Pumping Power Required:

$$P = \frac{\text{flow (gpm)} \times \text{head (ft of water)} \times \text{specific gravity (unitless)}}{3960 \times \text{pump efficiency (unitless)}}$$

$$P = \frac{300 \times (22+28+131) \times 1.046}{3960 \times 0.71} = 20.2 \text{ bhp [15.1 kW]}$$

##### Step 3:

Pump Efficiency Correction (due to viscosity increase from Table 4-A3) = 0.93\* x 0.71 = 0.66

\* Value found from Hydraulic Institute Standard 9.6.7.

##### Resultant Pumping Power Required:

$$P = \frac{300 \times 181 \times 1.046}{3960 \times 0.66} = 21.7 \text{ bhp [16.2 kW]} \text{ for 40\% by volume glycol solution}$$

**APPENDIX 4A: PROPYLENE GLYCOL – WATER SOLUTION**

<b>Table 4-A4 – Summary Results, Typical Example</b>		
<b>Items</b>	<b>Water</b>	<b>Propylene Glycol – Water Solution 40% by Volume 40 F [4.4 C]</b>
Flow Rate	200 gpm [12.6 L/s]	300 gpm [18.9 L/s]
Head	70 ft of water [209 kPa]	181 ft of water [541 kPa]
Power	5.0 bhp [3.7 kW]	21.7 bhp [16.2 kW]

**Application 2 – Heating Hot Water Freeze Protection**

A simple, all-water example follows:

A steam to hot water heat exchanger and an air handling unit hot water coil are connected by pipe and a water-based pump operating under conditions of:

- 40 gpm [2.5 L/s]
- 30 ft [90 kPa] total head
  - 20 ft [60 kPa] head due to pipe, valves and fittings
  - 10 ft [30 kPa] head due to equipment
- 140 F [60 C] fluid temperature
- 0.75 bhp [0.56 kW] and 50% efficiency pump
- Specific gravity = 1.0

The equipment is a steam to hot water heat exchanger and an air handling unit hot water coil. Determine the operating values of the same system if the fluid is changed to a solution of 40% glycol by volume.

**Step 1:**

Manufacturers are consulted and the hot water coil requires 50 gpm [3.2 L/s] and 4 ft [12 kPa] head and the heat exchanger pressure drop at 50 gpm is 10 ft [30 kPa] when using 40% glycol.

**Step 2:**

Using the pump affinity laws, correct the pipe, valves and fittings head for the new flow rate. At 50 gpm, the new head is 31 ft [93 kPa].

Total Dynamic Head Correction (due to viscosity increase) = 31 x 1.00 = 31 ft of water [93 kPa].

**Resultant Pumping Power Required:**

$$P = \frac{\text{flow (gpm)} \times \text{head (ft of water)} \times \text{specific gravity (unitless)}}{3960 \times \text{pump efficiency (unitless)}}$$

$$P = \frac{50 \times (4+10+31) \times 1.046}{3960 \times 0.50} = 1.19 \text{ bhp [0.89 kW]}$$

**Step 3:**

Pump Efficiency Correction (due to viscosity increase from Table 4-A3) =  $1.00^* \times 0.50 = 0.50$

\* Value found from Hydraulic Institute Standard 9.6.7.

For hot water applications, pump efficiency is not generally penalized due to viscosity. It is the designer's responsibility to confirm the correction factor Hydraulic Institute Standard 9.6.7, *Effects of Liquid Viscosity on Rotodynamic (Centrifugal and Vertical) Pump Performance*.

<b>Table 4-A5 – Summary Results, Typical Example</b>		
<b>Items</b>	<b>Water</b>	<b>Propylene Glycol – Water Solution 40% by Volume 140 F [60 C]</b>
Flow Rate	40 gpm [2.5 L/s]	50 gpm [3.2 L/s]
Head	30 ft of water [90 kPa]	45 ft of water [135 kPa]
Power	0.75 bhp [0.56 kW]	1.19 bhp [0.89 kW]

**Application 3 – Thermal Storage System (Ice)**

For thermal energy storage (ice) systems, consult the tank and chiller manufacturer for glycol correction sizing information and direction.

**4A.3 NOTES TO BE ADDED TO EQUIPMENT SCHEDULES**

**(a) Pumps**

For pumps using an aqueous solution of water and glycol, the designer shall add a remark that “Pump corrections have been applied” after calculating the appropriate correction factors. This remark shall be located on the pump equipment schedule.

**(b) Coils, Chillers, Heat Exchangers**

For coils, chillers and heat exchangers using an aqueous solution of water and glycol, the manufacturer shall increase the heat transfer surfaces to account for the percentage of glycol. The GPM, EWT, LWT and WPD indicated on the schedule shall be shown for the solution indicated, and not pure water. A remark shall be added that “Coil corrections have been applied for GPM, WPD, APD, EWT and LWT for the solution shown” (substitute chiller or heat exchanger as required) on the schedule.

CHAPTER 5: AUTOMATIC TEMPERATURE CONTROLS

Table of Contents

5.1 GENERAL ..... 5-2

5.2 BASIC DESIGN ..... 5-2

5.2.1 NEW STANDALONE FACILITY ..... 5-2

5.2.2 NEW FACILITY OR RENOVATION ..... 5-2

5.3 DETAILED DESIGN ..... 5-2

5.3.1 OPTION DESCRIPTIONS ..... 5-2

5.3.1.1 Option 1 ..... 5-2

5.3.1.2 Option 2 ..... 5-3

5.3.1.3 Option 3 ..... 5-3

5.3.1.4 Option 4 ..... 5-3

5.3.1.5 Option 5 ..... 5-3

5.4 BACNET CONTROLLER IDENTIFICATION ..... 5-3

5.5 SPECIFIC REQUIREMENTS ..... 5-3

5.5.1 CONTROL ACTUATORS ..... 5-3

5.5.2 CONTROL VALVES ..... 5-3

5.5.3 CONTROL DAMPERS ..... 5-3

5.5.4 END-SWITCHES ..... 5-3

5.5.5 SAFETIES ..... 5-4

5.5.6 CONTROL WIRING ..... 5-4

5.5.7 PERSONAL COMPUTER (PC) ..... 5-4

5.5.8 LAPTOP COMPUTER ..... 5-4

5.5.9 SOFTWARE ..... 5-4

5.5.10 COLOR GRAPHICS ..... 5-4

5.5.11 SPREADSHEETS ..... 5-4

5.5.12 SECURITY ..... 5-4

5.5.13 STATUS MONITORING ..... 5-4

5.5.14 ROOM TEMPERATURE SENSORS ..... 5-4

5.5.15 HUMIDITY SENSORS ..... 5-5

5.5.16 METERING REQUIREMENTS ..... 5-5

5.6 SYSTEM APPLICATIONS ..... 5-5

5.6.1 GENERAL ..... 5-5

5.6.2 AIRSIDE CONTROLS ..... 5-5

5.6.2.1 Air-Handling Units ..... 5-5

5.6.2.2 Individual Room Temperature Control ..... 5-6

5.6.3 HEATING SYSTEM CONTROLS ..... 5-6

5.6.4 CHILLED WATER SYSTEM CONTROLS ..... 5-7

5.6.5 NON-DDC CONTROLS ..... 5-7

5.7 DOCUMENTATION REQUIREMENTS ..... 5-8

5.7.1 SCHEMATIC DIAGRAM AND CONTROL SEQUENCE ..... 5-8

5.7.2 POINT LIST ..... 5-8

## **5.1 GENERAL**

Provide a Direct Digital Control (DDC) system for the Community Living Center, Domiciliary, and associated support functions, collectively referred to as the Facilities in this document. The DDC system shall control and monitor the HVAC systems and other systems. A central Engineering Control Center (ECC) **may or may not** be required for each project. All controls, including packaged equipment equipped with factory furnished DDC controls, shall be native BACnet-certified.

## **5.2 BASIC DESIGN**

### **5.2.1 NEW STANDALONE FACILITY**

Provide a new DDC control system, complete with DDC points, software, and hardware, including PC and/or laptop computer, color printer, local data gathering panels, sensors, control valves, dampers, flow meters, control wiring, graphics, and accessories, as required for a complete and workable system. The system shall be native BACnet-certified.

### **5.2.2 NEW FACILITY OR RENOVATION**

(a) The A/E shall determine the cost-effectiveness of the following options:

- Option 1 – Upgrade the ECC and existing DDC control system to a new BACnet-compatible control system; provide new controllers as required for new scope of work.
- Option 2 – Upgrade ECC; provide new controllers as required for new scope of work, utilize BACnet gateway for communication to existing DDC system.
- Option 3 – Provide new BACnet-compatible control system for new scope of work; existing DDC system to remain.
- Option 4 – Install new BACnet software package to existing ECC; install BACnet controllers for new scope of work; existing DDC system to remain.
- Option 5 – Integrate new scope of work into existing DDC system (same manufacturer).

(b) The interface with the existing ECC shall be seamless. The system shall include a personal computer (PC), laptop computers, color printer, distributed DDC controllers, panels, sensors, switches, alarms, flow meters, relays, control valves and dampers, wiring, system graphics, control sequences, and accessories to make a complete and workable system.

(c) Use of DDC controls shall result in energy-efficient operation and help achieve the mandated goal of energy conservation, described in [Chapter 1](#).

## **5.3 DETAILED DESIGN**

### **5.3.1 OPTION DESCRIPTIONS**

#### **5.3.1.1 Option 1**

Replace existing ECC with new BACnet Engineering Control Center (B-AWS), replace all existing DDC controllers with new BACnet controllers, install new BACnet communication network, install new building (B-BC) and equipment controllers (B-AAC, B-ASC) as required for new scope of work. Provide new portable operator's terminal.

**5.3.1.2 Option 2**

Replace existing ECC with new BACnet Engineering Control Center (B-AWS), install new BACnet gateway with full communication to existing controllers, install new BACnet communication network, install new building (B-BC) and equipment controllers (B-AAC, B-ASC) as required for new scope of work. Provide new portable operator's terminal.

**5.3.1.3 Option 3**

Install new BACnet Engineering Control Center (B-AWS). Install new building (B-BC) and equipment controllers (B-AAC, B-ASC) as required for new scope of work. Provide new portable operator's terminal. Existing ECC, associated communication network, and controllers to remain.

**5.3.1.4 Option 4**

Install new BACnet software on existing ECC which shall co-exist with current ECC operation software package, existing communication network to be re-used, install new building (B-BC) and equipment controller's (B-AAC, B-ASC) as required for new scope of work. Provide new portable operator's terminal.

**5.3.1.5 Option 5**

Integrate new scope of work into existing DDC system (same manufacturer).

**5.4 BACNET CONTROLLER IDENTIFICATION**

B-AWS	BACnet Advanced Workstation
B-BC	BACnet Building Controller
B-AAC	BACnet Advanced Application Controller
B-ASC	BACnet Application Specific Controller

**5.5 SPECIFIC REQUIREMENTS**

**5.5.1 CONTROL ACTUATORS**

Automatic control valves and dampers shall be equipped with electric actuators. Use of the pneumatic actuators is not permitted unless specifically requested by the medical center for renovation of existing facilities.

**5.5.2 CONTROL VALVES**

Select control valves with equal percentage, or linear flow characteristics. Provide bubble tight shutoff against 1.5 times design pressure. Utilize two-way, modulating control valves to the greatest extent possible. Select control Cv and pressure drop per manufacturer's recommendations. The A/E shall specify maximum pressure differential to ensure proper pumping capacity is available.

**5.5.3 CONTROL DAMPERS**

Select airfoil type control dampers with blade and edge seals to minimize air leakage while in the shutoff position. Show all damper sizes on the mechanical equipment floor plans and section drawings.

**5.5.4 END-SWITCHES**

Provide end-switches for 100% outdoor air dampers and duct-mounted smoke dampers. Dampers shall be fully open before the supply air fans are energized.

### **5.5.5 SAFETIES**

Provide hard-wired interlocked connections for all safety devices, such as freeze stats, smoke detectors, smoke dampers, and refrigerant leak detection devices. All safety devices shall be provided with additional dry contacts and shall be connected to the DDC system for monitoring and sequencing.

### **5.5.6 CONTROL WIRING**

Specify all UL-listed components and wiring installation in accordance with National Electric Code. All control wiring shall be installed in electric metallic tubing or conduits, unless otherwise approved by VA Authorities.

### **5.5.7 PERSONAL COMPUTER (PC)**

Provide a PC with the maximum available memory, hard-drive capacity, and processing speed at the time of design. Minimum PC configuration: Intel Core 2 Duo E8400 processor (3.0GHz, 6M, 1333MHz FSB), 8GB SDRAM, 1333MHz, 250GB 7,200 rpm SATA Hard Drive, Integrated Intel GMA 4500 Video, Windows 7 Professional with Windows Office Professional software package. Provide two 24 in [610 mm] flat screen monitors, expanded keyboard, CD drive, and a mouse. Provide two printers: one for status and one for reports. The report printer shall be color ink jet type. Coordinate the selection and location of the computer and associated equipment with the end-users.

### **5.5.8 LAPTOP COMPUTER**

The laptop computer shall be similar to the PC above with at least a 19 in [425 mm] color monitor.

### **5.5.9 SOFTWARE**

Provide an operator-programmable, pro-active software system, based on project-specific applications. All controllers shall be connected through a dedicated communication network to share common data and reports with the workstation. Provide download, upload, and all software configuration capabilities between the PC and the local controllers.

### **5.5.10 COLOR GRAPHICS**

Provide a complete dynamic color graphics package on the PC and laptop computers. Provide a schematic diagram for each control system and sub-system with the design set points and actual conditions. Indicate the mode of operation and alarm status.

### **5.5.11 SPREADSHEETS**

Provide Excel-type spreadsheet tables for each item of equipment to trend and log the data with set points, actual sensor readings, and status.

### **5.5.12 SECURITY**

Provide three levels of password protection to restrict altering the device set points.

### **5.5.13 STATUS MONITORING**

Provide current transducers (analog) for monitoring the status and energy of all fan (including cooling towers) and pump motors. Do not use differential pressure switches for status monitoring.

### **5.5.14 ROOM TEMPERATURE SENSORS**

Use commercial grade room temperature sensors with programmable temperature adjustment limits and night setback push button override capabilities. Specific sensor tolerances should be noted in project specifications.



**5.5.15 HUMIDITY SENSORS**

Use commercial grade duct and room mounted humidity sensors, accuracy of +/- 2% (0-90%).

**5.5.16 METERING REQUIREMENTS**

Coordinate metering requirements, with similar ongoing efforts (if any) at VA facilities, to ensure seamless integration and avoid duplication. Coordinate the efforts with the specification 25 10 10 – Advanced Utility Metering System.

**5.6 SYSTEM APPLICATIONS**

**5.6.1 GENERAL**

Listed below are generic control requirements for various HVAC systems. The list does not cover all control requirements and sub-sequences. Similarly, all control requirements may not be applicable to all situations. Using information given below, and other available resources, the A/E shall develop detailed control sequences for all systems.

**5.6.2 AIRSIDE CONTROLS**

Airside controls include operation of the air-handling units, exhaust systems, room level controls, and other miscellaneous controls.

**5.6.2.1 Air-Handling Units**

**(a) System Start-Up**

**(b) Morning Warm-Up Mode**

**(c) Morning Cool-Down Mode**

**(d) Unoccupied Mode**

**(e) Supply Air Temperature Control (include all applicable modes)**

- Heating Mode
- Mechanical Cooling Mode
- Economizer Cycle Mode
- Mechanical Cooling with Economizer Cycle Mode
- Supply Air Temperature Reset Control, where applicable

**(f) Freeze Protection Control – Pre-Heat Coil**

- Mixed Air Temperature Control
- Fan Operation Control
- Outside Air Damper Control

**(g) Fan Speed Control – Supply Air Fan**

Refer to ASHRAE Standard 90.1 - 2007 for mandated static pressure reset control

**(h) Fan Tracking Control – Supply and Return Air Fans**

**(i) Minimum Ventilation Air – Outdoor Air Control**

Include demand control ventilation, where applicable

**(j) Smoke Detector/Smoke Damper Operation**

**(k) Filter Maintenance Alarm**

- Pre-Filters
- After-Filters
- Final-Filters

**(l) Volumetric Data**

- Supply Air Volume – cfm [L/s]
- Return Air Volume – cfm [L/s]
- Minimum Ventilation Air (Outdoor Air) – cfm [L/s]

**(m) Heat Recovery System Operation**

- Applicable for 100% outdoor air for ventilation systems
- Run Around Coil
- Heat Recovery Coil

**(n) Humidity Control**

- Humidification Mode with Operating and High-Limit Controls
- High-Humidity Controls – Mechanical Cooling Mode

**(o) Special Exhaust Systems**

- Wet Exhaust

**5.6.2.2 Individual Room Temperature Control**

**(a) Constant Volume Air Terminal Unit**

- See Figure 5-1

**(b) Variable Volume Air Terminal Unit**

- With Dead-Band (see Figure 5-2)
- Without Dead-Band (see Figure 5-3)

**(c) Fan Coil Unit Control**

- Four-Pipe System
- Two-Pipe System

**(d) Ground Source Heat Pump (GSHP) Control**

- Variable Speed Pump Control
- Seasonal Shutdown

**5.6.3 HEATING SYSTEM CONTROLS**

**(a) Pumping System Controls**

- Start-Up with Automatic Changeover (Emergency and Equal Runtime)
- Primary-Secondary Piping/Pumping Control
- Variable Primary Piping/Pumping Control, where applicable

**(b) Heat Exchanger Controls Leaving Water Temperature Control**

- Water Temperature Reset Control

### (c) Boiler Controls

- Safety Controls
- Outdoor Air Reset
- Integration with the Central DDC (ECC) Controls

### (d) Geothermal Heating Control

- Safety Controls
- Outdoor Air Reset

## 5.6.4 CHILLED WATER SYSTEM CONTROLS

### (a) Standalone Chilled Water Plant

- System Start-Up
- Automatic Part-Load Operation
- Chiller Safety Controls and Interlock with Central DDC System

### (b) Chilled Water Temperature Control

- Fixed Water Temperature Control (Leaving Chiller)
- Reset Water Temperature Control, where applicable

### (c) Pumping System Control

- Start-Up with Automatic Changeover (Emergency and Equal Runtime)
- Primary-Secondary Piping/Pumping Control
- Variable-Primary Piping/Pumping Control, where applicable
- Minimum Pump Speed Control

### (d) Cooling Tower Control

- Leaving Water Temperature Control
- Fan Speed Control
- Vibration Isolation Control
- Make-Up Water Control
- Basin Temperature Control
- Water Treatment Controls Including Integration with DDC Controls
- Plate Heat Exchanger Control (Economizer Mode, where applicable)

### (e) Thermal Energy Storage Control – Water or Ice

- Storage Capacity
- Special Equipment Requirements
- Utility Rate Information
- Recharge/Discharge Control
- Cooling Tower Temp Control Requirements

## 5.6.5 NON-DDC CONTROLS

For standalone closed-loop applications, DDC controls and connection to the central ECC system shall be eliminated if it is determined that remote monitoring, alarm, and start-up are not necessary. Such applications are generally non-critical and shall be evaluated on a case-by-case basis. Specific applications may require DDC temperature sensors for high or low limit alarms.

Examples of closed-loop controls are:

- Vestibule Heater
- Exterior Stairs Heater
- Attic Heating and Exhaust Ventilation Systems
- Mechanical Equipment Room Heating and Ventilation Control

## **5.7 DOCUMENTATION REQUIREMENTS**

### **5.7.1 SCHEMATIC DIAGRAM AND CONTROL SEQUENCE**

Provide a control diagram showing all controlled devices with unique designation numbers, such as valves V-1 and V-2, dampers D-3 and D-4, etc. Describe the role of each controlled device in the sequence of operation. Describe the sequence of operation in all modes, generally as outlined above.

***The control schematic diagram and the written specific sequence of operation shall be included in the contract drawings. Do NOT include the sequence of operation in the specifications.***

### **5.7.2 POINT LIST**

Provide a comprehensive DDC point schedule for each system. Provide a list of all analog and binary points, alarm requirements, and measurement needs. Sample point lists are shown in Figure 5-4, Figure 5-5, Figure 5-6, Figure 5-7, and Figure 5-8.

# HVAC DESIGN MANUAL

## CHAPTER 5

FIGURE 5-1

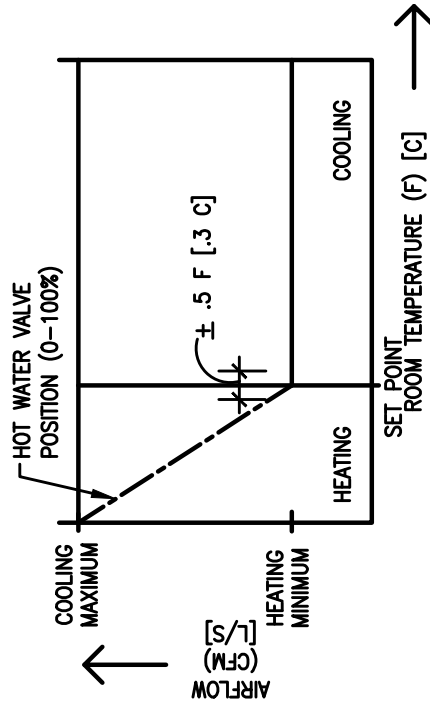
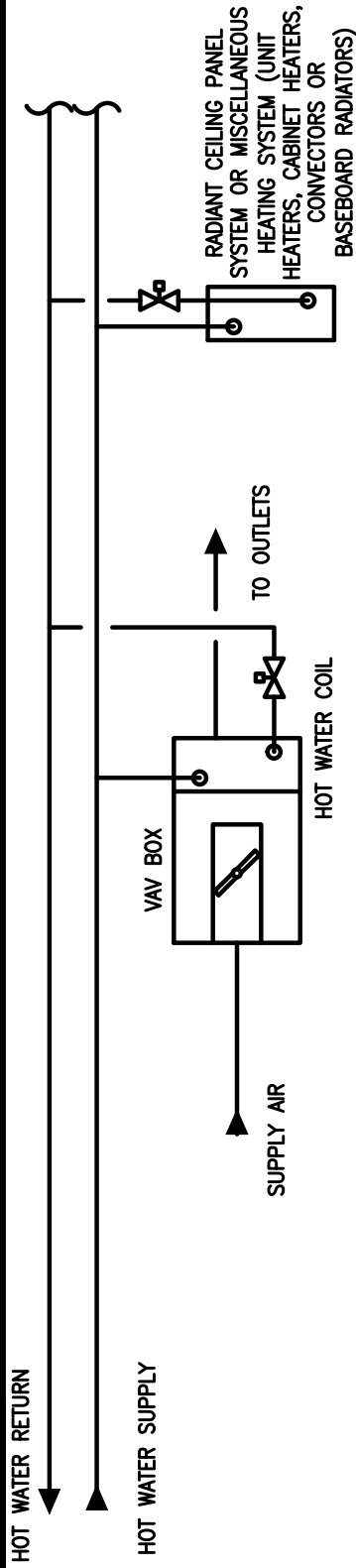

VAV BOX CONTROL SEQUENCE

### CONTROL SEQUENCES

CASE 1: NO PERIMETER HEATING

- A. HOT WATER VALVE ENABLED AT ALL TIMES.
- B. HOT WATER VALVE OPENS IF ROOM TEMPERATURE IS LESS THAN SET POINT.

CASE 2: WITH RADIANT CEILING PANEL SYSTEM

- A. RADIANT PANEL CONTROL VALVE ENABLED BELOW A SPECIFIED OUTSIDE AIR TEMPERATURE.
- B. IF CV BOX HOT WATER VALVE IS 100% OPEN AND ROOM TEMPERATURE IS LESS THAN SETPOINT, RADIANT CEILING PANEL HOT WATER VALVE MODULATES OPEN TO MAINTAIN ROOM TEMPERATURE SET POINT.

CASE 3: WITH MISCELLANEOUS HEATING

- A. CONTROL VALVE FOR MISCELLANEOUS HEATING SYSTEM ENABLED BELOW A SPECIFIED OUTSIDE AIR TEMPERATURE.
- B. IF CV BOX HOT WATER VALVE IS 100% OPEN (AND RADIANT CEILING PANEL SYSTEM VALVE, IF INSTALLED) AND ROOM TEMPERATURE IS LESS THAN SETPOINT, MISCELLANEOUS HEATING HOT WATER VALVE MODULATES TO MAINTAIN ROOM TEMPERATURE.

## CV TERMINAL UNIT WITH REHEAT AND PERIMETER HEATING

Not to Scale

# HVAC DESIGN MANUAL

CHAPTER 5

FIGURE 5-2

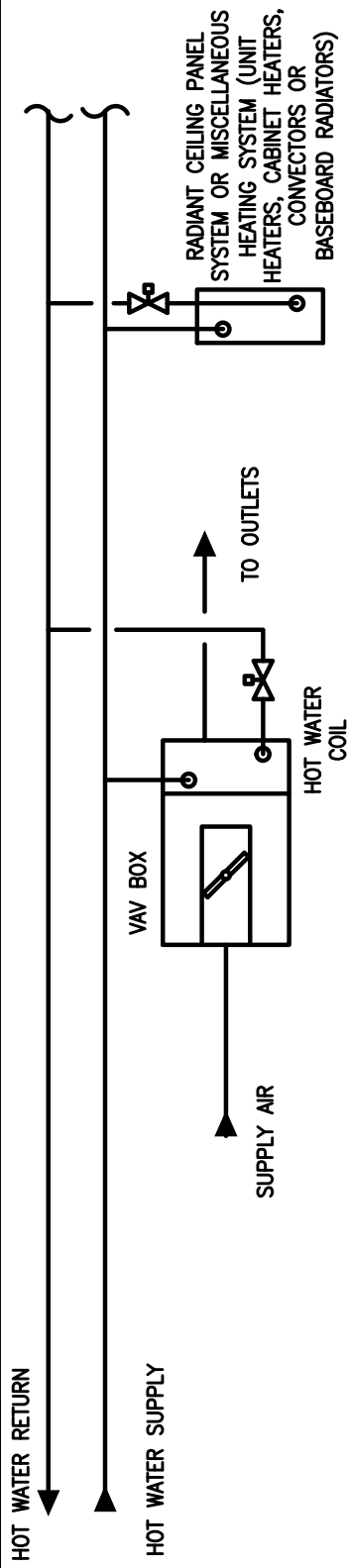

### CONTROL SEQUENCES

- CASE 1: NO PERIMETER HEATING**
- A. HOT WATER VALVE ENABLED AT ALL TIMES.
  - B. HOT WATER VALVE OPENS IF ROOM TEMPERATURE IS LESS THAN LOWER LIMIT.
- CASE 2: WITH RADIANT CEILING PANEL SYSTEM**
- A. RADIANT PANEL CONTROL VALVE ENABLED BELOW A SPECIFIED OUTDOOR AIR TEMPERATURE.
  - B. IF VAV BOX HOT WATER VALVE IS 100% OPEN AND ROOM TEMPERATURE IS LESS THAN SETPOINT, RADIANT CEILING PANEL HOT WATER VALVE MODULATES OPEN TO MAINTAIN ROOM TEMPERATURE SET POINT.
- CASE 3: WITH MISCELLANEOUS HEATING**
- A. CONTROL VALVE FOR MISCELLANEOUS HEATING SYSTEM ENABLED BELOW A SPECIFIED OUTSIDE AIR TEMPERATURE.
  - B. IF VAV BOX HOT WATER VALVE IS 100% OPEN (AND RADIANT CEILING PANEL SYSTEM VALVE, IF INSTALLED) AND ROOM TEMPERATURE IS LESS THAN SETPOINT, MISCELLANEOUS HEATING HOT WATER VALVE MODULATES TO MAINTAIN ROOM TEMPERATURE.

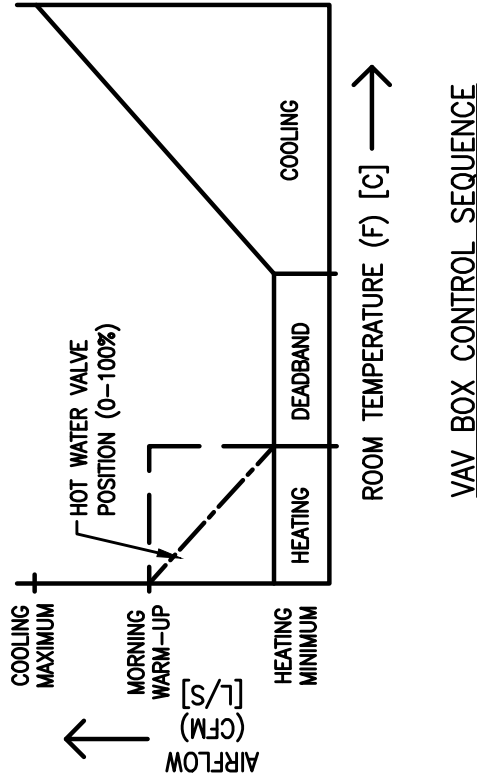

## VAV TERMINAL UNIT WITH REHEAT AND PERIMETER HEATING, WITH 5 F [3 C] DEADBAND

Not to Scale

# HVAC DESIGN MANUAL

## CHAPTER 5

FIGURE 5-3

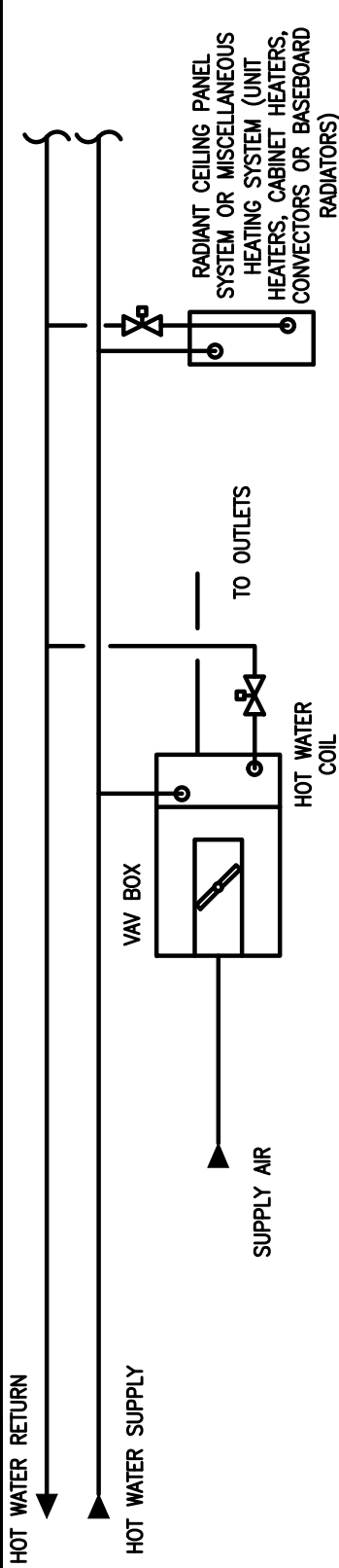

### CONTROL SEQUENCES

#### CASE 1: NO PERIMETER HEATING

- A. HOT WATER VALVE ENABLED AT ALL TIMES.
- B. HOT WATER VALVE OPENS IF ROOM TEMPERATURE IS LESS THAN LOWER DEADBAND LIMIT.

#### CASE 2: WITH RADIANT CEILING PANEL SYSTEM

- A. RADIANT PANEL CONTROL VALVE ENABLED BELOW A SPECIFIED OUTSIDE AIR TEMPERATURE.
- B. IF VAV BOX HOT WATER VALVE IS 100% OPEN AND ROOM TEMPERATURE IS LESS THAN SETPOINT, RADIANT CEILING PANEL HOT WATER VALVE MODULATES OPEN TO MAINTAIN ROOM TEMPERATURE SET POINT.

#### CASE 3: WITH MISCELLANEOUS HEATING

- A. CONTROL VALVE FOR MISCELLANEOUS HEATING SYSTEM ENABLED BELOW A SPECIFIED OUTSIDE AIR TEMPERATURE.
- B. IF VAV BOX HOT WATER VALVE IS 100% OPEN (AND RADIANT CEILING PANEL SYSTEM VALVE, IF INSTALLED) AND ROOM TEMPERATURE IS LESS THAN SETPOINT, MISCELLANEOUS HEATING HOT WATER VALVE MODULATES TO MAINTAIN ROOM TEMPERATURE.

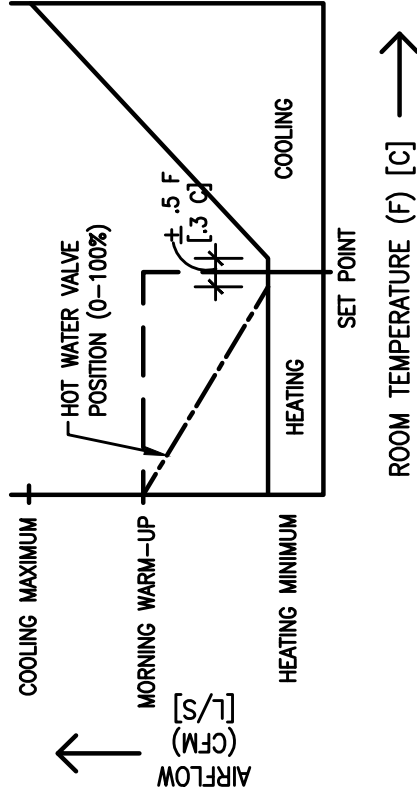

VAV BOX CONTROL SEQUENCE

## VAV TERMINAL UNIT WITH REHEAT AND PERIMETER HEATING - 0 F [-18 C] DEADBAND

Not to Scale

**HVAC DESIGN MANUAL**  
**CHAPTER 5**  
**FIGURE 5-4**

AIR HANDLING SYSTEMS															
System Component	Point ID	System Outputs		System Inputs					System Software/Control						
		Binary	Analog	Binary	Temperature	Pressure	Humidity	Flow	Current	Data (Comm Line)	Alarm Status	Low Limit	High Limit	Lead/Lag	Application/Function
Supply Fan	On/Off														
	Start/Stop	X							X						X
	Status Auto			X											
	Status Hand			X						X					
Return Fan	VFD Control Panel														
	On/Off														
	Start/Stop	X													X
	Status Auto			X											
Relief Fan	Status Hand			X											
	VFD Control Panel									X					
	On/Off														
	Start/Stop	X													X
Exhaust Fan	Status Auto			X											
	Status Hand			X											
	VFD Control Panel									X					
	On/Off														
Glycol Energy Recovery Pump	On/Off														
	Start/Stop	X													X
	Status Auto			X											
	Status Hand			X											
Glycol Energy Recovery Pump	On/Off														
	Start/Stop	X													X

**AIR HANDLING SYSTEM OVERVIEW**



# HVAC DESIGN MANUAL

## CHAPTER 5

### FIGURE 5-4 (CONTINUATION)

#### AIR HANDLING SYSTEMS

System Component	Point ID	System Outputs		System Inputs					System Software/Control							
		Binary	Analog	Binary	Temperature	Pressure	Humidity	Flow	Current	Data (Comm Line)	Alarm Status	Equipment Status	Low Limit	High Limit	Lead/Lag	Start/Stop
Status Auto				X												
Status Hand				X												
Outdoor Air Temperature					X											
Outdoor Air Humidity							X									
Mixed Air Temperature					X							X	X			
Heat Recovery Exhaust Coil Temperature					X							X	X			
Heat Recovery Supply Coil Temperature					X							X	X			
Heat Recovery Three Defrost Valve												X	X			
Heat Recovery Pump Status					X											X
Heat Recovery Exhaust Filter Status					X											
Preheat Coil Temperature								X				X	X			
Chilled Water Coil Temperature								X				X	X			
Supply Air Temperature								X				X	X			
Supply Air Humidity - High Limit									X			X	X			
Indoor Temperature												X	X			
Pre-Filter (PF-1) Status													X			
Pre-Filter (PF-2) Status													X			
Freeze/Stat Status													X			
Duct Mounted Smoke Detector Status													X			
Static Pressure Sensor													X			
Relief Air Damper Position														X		
Minimum Outdoor Air Damper Position					X											
Maximum Outdoor Air Damper Position					X											
Mixed Air Damper Position					X											
Air Flow Measuring Station															X	
VAV Box Flow															X	
VAV Box Supply Air Temperature														X		X

#### AIR HANDLING SYSTEM OVERVIEW

# HVAC DESIGN MANUAL

## CHAPTER 5

FIGURE 5-5

CHILLED WATER SYSTEM																			
System Component	Point ID	System Outputs				System Inputs							System Software/Control						
		Binary	Analog	Binary	Binary	Status	Temperature	Pressure	Level	Flow	Current	Totalization	Conductivity	ORP	pH	Data (Com Line)	Alarm Processing	Application/Function	
Chilled Water Pump																			
On/Off																			
Start/Stop																			
VFD Control Panel Data																			
Chilled Water Supply Temperature							X												
Chilled Water Return Temperature							X												
Chilled Water Supply Flow									X										
Chilled Water Differential Pressure								X											
Chiller Control Panel																			
Safeties/Failures																			
On/Off																			
Start/Stop																			
Data																			
Chilled Water Pump																			
On/Off																			
Start/Stop																			
Status Auto																			
Status Hand																			
VFD Control Panel Data																			
P&F Economizer																			
Chilled Water Supply Temperature							X												
Chilled Water Return Temperature							X												
Chiller kW																			
Chilled Water Pump kW																			

## CHILLED WATER SYSTEM OVERVIEW

# HVAC DESIGN MANUAL

## CHAPTER 5

FIGURE 5-6

CONDENSER WATER SYSTEM																					
System Component	Point ID	System Outputs				System Inputs						System Software/Control									
		Binary	Analog	Binary	Position %	Status	Current	Temperature	Ph	Siemens	Percent	Volume	Data	Equipment Status	Low Limit	High Limit	Lead/Lag	Start/Stop	Run Time	Counter	
Condenser Water Piping System																					
Condenser Water Pump																					
On/Off						X															
Start/Stop																					
Status Auto						X															
Status Hand						X															
Cooling Tower Entering Water Temperature								X													
Cooling Tower Leaving Water Temperature								X													
Condenser Water Valve at Chiller									X												
Automatic Strainer Backwash Counter																					X
Cooling Tower Fan																					
On/Off						X															
Start/Stop																					
VFD Control Panel Data																					
Cooling Tower Valve																					
Cooling Tower Fan Vibration						X															
Cooling Tower Sump Temperature								X													
Cooling Tower Sump Level						X															
Chemical Feed System																					
Chemical Feed Controller																					
Conductivity																					
ph									X												
Make Up Volume																					
Blow Down Volume																					
Chemical Feed Pumps																					
Biocide Inhibitor																					
Scale and Corrosion Inhibitor						X															
Chemical Drum Level						X															
Cooling Tower Fan kW						X															
Condenser Water Pump kW						X															

## CONDENSER WATER SYSTEM OVERVIEW

**HVAC DESIGN MANUAL**  
**CHAPTER 5**  
**FIGURE 5-7**

**HEATING SYSTEM**

	System Outputs				System Inputs							System Software/Control					
	Point ID	Binary		Command	Position %	Status	Temperature	Pressure	Differential Pressure	Level	Analog		Equipment Status	Alarm Processing		Application/Function	
		Binary	Analog								Flow	Current		Totalization	Conductivity		ORP
Hot Water Pump												X			X		
Oni/Off																	
Start/Stop			X													X	
VFD Control Panel Data												X					
Hot Water Supply Temperature						X									X		
Hot Water Return Temperature						X								X	X		
Hot Water Flow												X					
Boiler Control Panel																	
Safeties/Failures																X	
Oni/Off						X											
Start/Stop			X							X							
Control Panel Data																X	
																	X

**HEATING SYSTEM OVERVIEW**

**HVAC DESIGN MANUAL**  
**CHAPTER 5**  
**FIGURE 5-8**

MISCELLANEOUS EQUIPMENT AND SYSTEMS																				
System Component	Point ID	System Outputs			System Inputs										System Software/Control					
		Binary	Analog	Binary	Temperature	Pressure	Differential Pressure	Level	Flow	Current	Totalization	Conductivity	ORP	Data (Com Line)	Equipment Status	Alarm Processing	Low Limit	High Limit	Lead/Lag	Application/Function
Freezers and Refrigerators																				
Medical Air				X													X			
Safeties/Failures				X					X											
Oxygen				X													X			
Medical Vacuum				X																
Emergency Generators				X																
Control Panel Data																				
Domestic Hot Water Supply Temperature																				
Domestic Hot Water Return Temperature																				
Domestic Hot Water Pump																				
Sewage Pumps																				
Elevator Machine Room Temperature																				
Electrical Room Temperature																				

**MISCELLANEOUS SYSTEM OVERVIEW**



**CHAPTER 6: CLIMATIC DATA**

Table of Contents

Table 6-1 CLIMATIC CONDITIONS..... 6-2  
Table 6-2 HIGH HUMIDITY LOCATIONS ..... 6-17  
Table 6-3 LOW HUMIDITY LOCATIONS ..... 6-18

<b>Table 6-1 CLIMATIC CONDITIONS</b>																	
Location	Weather Station	North Latitude	MSL Elevation	Col. 1a 0.4%		Col. 1b 99.6%		Col. 2a 1%		Col. 2b 99%		Col. 3 Wet Bulb		Annual Extreme Daily-Mean Db			
				Temperatures										0.4%	1%	Maximum	Minimum
				Summer		Winter		Summer		Winter							
				Db	Wb	Db	Db	Wb	Db								
<b>ALABAMA</b>																	
Birmingham	Birmingham Municipal AP	33.56	630	95.0	75.1	19.6	92.6	74.9	24.0	78.5	77.6	97.5	10.7				
Montgomery	Montgomery Dannelly Fld	32.30	203	96.2	76.5	23.7	94.0	76.1	27.3	79.7	78.5	99.2	15.2				
Tuscaloosa	Tuscaloosa Municipal AP	33.21	187	95.7	76.5	20.6	93.4	76.3	25.0	79.8	78.7	98.9	12.0				
Tuskegee*	Tuskegee AP	32	195	96	79	22	95	79	22	-	-	-	-				
<b>ALASKA</b>																	
Anchorage	Anchorage Intl AP	61.18	131	71.4	58.7	-8.9	68.3	57.3	-4.4	60.3	58.8	76.4	-14.1				
<b>ARIZONA</b>																	
Phoenix	Phoenix Sky Harbor Intl AP	33.44	1106	110.2	70.0	38.6	108.1	69.8	41.3	76.1	75.2	114.5	34.4				
Prescott	Prescott Love Fld	34.65	5052	94.3	61.2	17.5	91.4	60.6	20.7	67.1	65.7	98.6	9.9				
Tucson	Tucson Intl AP	32.13	2556	105.9	66.2	31.7	103.6	66.0	34.4	72.5	71.7	109.9	26.4				
<b>ARKANSAS</b>																	
Fayetteville	Fayetteville Drake Fld	36.01	1260	95.2	75.2	8.0	92.7	74.8	14.6	78.0	77.0	98.8	1.1				
Little Rock	Little Rock AFB	34.92	338	99.3	77.3	15.3	96.3	77.5	20.4	81.1	80.0	101.7	7.9				
N. Little Rock	North Little Rock/Adams Fld	34.83	1152	95.2	76.4	16.4	92.8	76.1	21.9	78.9	77.8	98.3	10.9				



Table 6-1 CLIMATIC CONDITIONS																	
Location	Weather Station	North Latitude	MSL Elevation	Col. 1a 0.4%		Col. 1b 99.6%		Col. 2a 1%		Col. 2b 99%		Col. 3 Wet Bulb		Annual Extreme Daily-Mean Db			
				Temperatures										0.4%	1%	Maximum	Minimum
				Summer		Winter		Summer		Winter							
				Db	Wb	Db	Db	Wb	Db								
CALIFORNIA																	
Fresno	Fresno Yosemite Intl AP	36.78	328	103.6	71.2	31.5	101.1	70.0	33.7	73.7	72.2	107.9	28.6				
Livermore*	Livermore Municipal AP	37.69	397	98.8	69.2	30.3	94.7	67.2	32.9	70.8	68.7	105.9	26.9				
Loma Linda	March AFB/Riverside	33.88	1516	100.6	67.8	34.2	98.6	67.2	36.6	72.4	71	107.3	28.8				
Long Beach	Long Beach Daugherty Fld	33.83	39	91.2	67.9	41.2	87.6	67.3	43.5	72.5	71.0	101.1	36.2				
Los Angeles	Los Angeles Intl AP	33.94	325	83.7	64.3	44.4	80.4	64.7	46.5	70.2	69.0	93.8	40.0				
Martinez*	Concord	38	195	100	7	24	97	70	24	-	-	-	-				
Palo Alto	San Jose Intl AP	37.36	49	92.3	66.9	35.7	88.6	66.2	37.8	69.5	68.1	100.0	31.9				
Menlo Park	San Jose Intl AP	37.36	49	92.3	66.9	35.7	88.6	66.2	37.8	69.5	68.1	100.0	31.9				
San Diego	San Diego Lindbergh Fld	32.74	30	84.1	67.7	44.8	81.1	67.5	46.8	72.9	71.3	92.3	41.0				
San Francisco	San Francisco Intl AP	37.62	20	83.0	63.0	38.8	78.3	62.1	40.8	65.4	64.0	94.3	35.3				
Sepulveda	Burbank-Glendale-Pasadena AP	34.20	732	98.3	68.8	39.0	94.6	68.3	41.5	73.4	71.7	105.6	33.7				
COLORADO																	
Denver	Denver Stapleton Intl AP	39.77	5285	93.5	60.6	-4.0	90.8	60.1	3.3	64.6	63.5	98.9	-12.2				
Ft. Lyon*	La Junta Municipal AP	38.05	4216	99.8	64.5	0.0	97.3	64.0	7.1	68.5	67.6	104.7	-5.9				
Grand Junction	Grand Junction	39.13	4839	97.4	61.9	6.0	94.8	60.9	11.7	65.5	64.4	101.3	1.1				

<b>Table 6-1 CLIMATIC CONDITIONS</b>																	
Location	Weather Station	North Latitude	MSL Elevation	Col. 1a 0.4%		Col. 1b 99.6%	Col. 2a 1%		Col. 2b 99%	Col. 3 Wet Bulb		Annual Extreme Daily-Mean Db					
				Temperatures										0.4%	1%	Maximum	Minimum
				Summer		Winter	Summer		Winter								
				Db	Wb	Db	Db	Wb	Db								
<b>CONNECTICUT</b>																	
Newington	Hartford/ Brainard Fld	41.74	20	90.5	73.4	6.4	87.8	72.7	10.6	77.2	75.4	N/A	N/A				
West Haven*	West Haven AP	41	6	88	76	3	84	76	3	-	-	-	-				
<b>DELAWARE</b>																	
Wilmington	Wilmington New Castle Co AP	39.67	79	91.9	75.1	11.7	88.9	74.1	16.1	78.0	76.8	96.4	4.5				
<b>DISTRICT OF COLUMBIA</b>																	
Washington DC	Washington DC Reagan AP	38.87	66	94.3	76.0	16.3	91.7	75.2	20.3	78.6	77.5	98.1	9.9				
<b>FLORIDA</b>																	
Bay Pines	St. Petersburg Clearwater AP	27.92	10	93.2	78.8	42.6	91.6	78.2	45.8	82.1	81.2	95.4	33.9				
Coral Gables	Miami/Kendall-Tamia	25.65	10	92.4	77.8	45.4	91.2	77.6	49.0	80.3	79.5	96.2	39.3				
Gainesville	Gainesville Regional AP	29.69	164	93.5	76.5	29.7	92.0	76.3	33.4	79.7	78.7	97.4	22.6				
Lake City	Gainesville Regional AP	29.69	164	93.5	76.5	29.7	92.0	76.3	33.4	79.7	78.7	97.4	22.6				
Miami	Miami Intl AP	25.82	30	91.8	77.6	47.7	90.7	77.5	51.7	80.2	79.5	95.1	41.1				
Orlando	Orlando Executive AP	28.55	112	93.6	76.0	40.0	91.1	75.8	44.2	79.7	78.8	96.6	33.5				
Tampa	Tampa Intl AP	27.96	10	92.4	77.4	38.4	91.3	77.3	42.5	80.5	79.9	95.0	30.8				

Table 6-1 CLIMATIC CONDITIONS																	
Location	Weather Station	North Latitude	MSL Elevation	Col. 1a 0.4%		Col. 1b 99.6%		Col. 2a 1%		Col. 2b 99%		Col. 3 Wet Bulb		Annual Extreme Daily-Mean Db			
				Temperatures										0.4%	1%	Maximum	Minimum
				Summer		Winter		Summer		Winter							
				Db	Wb	Db	Db	Wb	Db								
<b>GEORGIA</b>																	
Atlanta	Atlanta Hartsfield Intl AP	33.64	1027	93.8	74.3	20.7	91.5	74.0	25.8	77.2	76.2	96.5	11.8				
Augusta	Augusta Bush Fld	33.37	148	97.1	76.2	22.2	94.7	76.0	25.8	79.4	78.3	100.7	14.8				
Dublin*	Dublin AP	32	215	96	79	21	93	78	21	-	-	-	-				
Decatur	Atlanta Hartsfield Intl AP	33.64	1027	93.8	74.3	20.7	91.5	74.0	25.8	77.2	76.2	96.5	11.8				
<b>HAWAII</b>																	
Honolulu	Honolulu Intl AP	21.33	16	89.9	74.0	61.2	89.1	73.6	63.3	77.2	76.3	91.6	57.5				
<b>IDAHO</b>																	
Boise	Boise Air Terminal	43.57	2867	98.1	64.2	2.7	95.0	63.1	10.5	66.3	65.0	103.7	1.0				
<b>ILLINOIS</b>																	
Chicago W. Side	Chicago Ohare Intl AP	41.99	673	91.9	74.6	-4.0	89.0	73.4	2.2	77.9	76.1	96.7	-10.7				
Chicago Lakeside	Chicago Ohare Intl AP	41.99	673	91.9	74.6	-4.0	89.0	73.4	2.2	77.9	76.1	96.7	-10.7				
Danville*	Danville	40	558	93	78	-3	90	77	-4	-	-	-	-				
Downey*	Waukegan	42	680	92	78	-6	89	76	-6	-	-	-	-				
Hines	Chicago Midway AP	41.79	617	92.1	74.9	-1.6	89.6	73.3	-6	78	76.2	97.3	-8.2				
Marion*	Mt. Vernon (AWOS)	38.32	479	93.3	76.5	4.6	91.1	76.1	10.9	80.6	78.4	97.2	-6.6				

<b>Table 6-1 CLIMATIC CONDITIONS</b>																	
Location	Weather Station	North Latitude	MSL Elevation	Col. 1a 0.4%		Col. 1b 99.6%	Col. 2a 1%		Col. 2b 99%	Col. 3 Wet Bulb		Annual Extreme Daily-Mean Db					
				Temperatures										0.4%	1%	Maximum	Minimum
				Summer		Winter	Summer		Winter								
				Db	Wb	Db	Db	Wb	Db								
<b>INDIANA</b>																	
Ft Wayne	Ft. Wayne Intl AP	41.01	827	91.1	74.4	-2.6	88.4	73.1	3.8	77.6	75.9	94.7	-8.6				
Indianapolis	Indianapolis Intl AP	39.71	807	91.1	75.3	-0.5	88.6	74.4	6.4	78.2	76.9	94.2	-7.7				
Marion*	Marion	40	791	91	77	-4	90	75	-4	-	-	-	-				
<b>IOWA</b>																	
Des Moines	Des Moines Intl AP	41.54	965	93.4	76.2	-6.9	90.2	75.0	-1.6	78.4	77.1	97.6	-12.3				
Iowa City*	Iowa City	41	645	92	80	-11	89	78	-11	-	-	-	-				
Knoxville	Des Moines Intl AP	41.54	965	93.4	76.2	-6.9	90.2	75.0	-1.6	78.4	77.1	97.6	-12.3				
<b>KANSAS</b>																	
Leavenworth	Kansas City Intl AP, MO	39.30	1024	96.2	76.3	-1	92.7	75.8	-3.4	79.5	78	100.2	-6.2				
Topeka	Topeka Municipal AP	39.07	886	97.1	75.8	0.6	94.1	75.8	6.7	78.9	77.7	101.4	-5.7				
Wichita	Wichita Mid-Continent AP	37.65	1339	100.4	73.3	4.0	97.2	73.4	10.5	77.4	76.3	104.9	-0.8				
<b>KENTUCKY</b>																	
Lexington	Lexington Bluegrass AP	38.04	988	91.7	73.9	6.0	89.3	73.7	12.7	77.3	76.0	95.2	-1.9				
Louisville	Louisville	38.18	489	93.4	75.7	8.0	91.2	75.3	14.5	78.7	77.5	96.7	0.9				
<b>LOUISIANA</b>																	
Alexandria	Alexandria Intl AP	31.33	89	96.6	77.5	26.7	93.6	77.2	29.7	80.8	79.8	99.0	20.1				

Table 6-1 CLIMATIC CONDITIONS																	
Location	Weather Station	North Latitude	MSL Elevation	Col. 1a 0.4%		Col. 1b 99.6%		Col. 2a 1%		Col. 2b 99%		Col. 3 Wet Bulb		Annual Extreme Daily-Mean Db			
				Temperatures										0.4%	1%	Maximum	Minimum
				Summer		Winter		Summer		Winter							
				Db	Wb	Db	Db	Wb	Db								
New Orleans	New Orleans Lakefront AP	30.04	10	93.4	78.7	35.6	92.0	78.3	38.8	81.4	80.5	96.8	29.6				
Shreveport	Shreveport Regional AP	32.45	259	97.8	76.3	23.8	95.4	76.4	27.7	79.4	78.7	100.8	17.7				
MAINE																	
Togus	Augusta AP	44.32	361	87.0	70.6	-3.9	83.7	107.7	0.8	73.5	71.6	93.0	-10.1				
MARYLAND																	
Baltimore	Baltimore-Washington Intl AP	39.17	154	93.9	74.9	12.9	91.2	74.2	17.3	78.1	76.8	98.0	5.1				
Perry Point	Baltimore-Washington Intl AP	39.17	154	93.9	74.9	12.9	91.2	74.2	17.3	78.1	76.8	98.0	5.1				
MASSACHUSETTS																	
Bedford	Boston Logan Intl AP	42.36	30	90.8	73.3	7.4	87.6	71.9	12.4	76.2	74.6	95.6	2.3				
Boston	Boston Logan Intl AP	42.36	30	90.8	73.3	7.4	87.6	71.9	12.4	76.2	74.6	95.6	2.3				
Brockton*	Taunton	41	20	89	75	5	86	74	5	-	-	-	-				
North Hampton*	Springfield/Westover AFB	42	247	90	75	-5	87	73	-5	-	-	-	-				
West Roxbury	Boston Logan Intl AP	42.36	30	90.8	73.3	7.4	87.6	71.9	12.4	76.2	74.6	95.6	2.3				
MICHIGAN																	
Ann Arbor*	Ypsilanti	42	777	92	75	1	89	74	1	-	-	-	-				
Allen Park	Detroit Metro AP	42.22	663	90.3	73.8	1.4	87.4	72.5	6.7	76.9	75.0	94.9	-4.5				
Battle Creek*	Battle Creek AP	42	939	92	76	1	88	74	1	-	-	-	-				

<b>Table 6-1 CLIMATIC CONDITIONS</b>																	
<b>Location</b>	<b>Weather Station</b>	<b>North Latitude</b>	<b>MSL Elevation</b>	<b>Col. 1a 0.4%</b>		<b>Col. 1b 99.6%</b>	<b>Col. 2a 1%</b>		<b>Col. 2b 99%</b>	<b>Col. 3 Wet Bulb</b>		<b>Annual Extreme Daily-Mean Db</b>					
				<b>Temperatures</b>										<b>0.4%</b>	<b>1%</b>	<b>Maximum</b>	<b>Minimum</b>
				<b>Summer</b>		<b>Winter</b>	<b>Summer</b>		<b>Winter</b>								
				<b>Db</b>	<b>Wb</b>	<b>Db</b>	<b>Db</b>	<b>Wb</b>	<b>Db</b>								
Detroit	Detroit Metro AP	42.22	663	90.3	73.8	1.4	87.4	72.5	6.7	76.9	75.0	94.9	-4.5				
Iron Mountain*	Iron Mountain/Ford	45.82	1181	88.2	72.2	-10.7	84.1	70.0	-6.2	74.7	72.3	92.8	-20.2				
Saginaw	Saginaw Tri City Intl AP	43.53	669	88.9	73.6	0.0	86.5	71.8	3.6	76.4	74.5	95.2	-6.3				
<b>MINNESOTA</b>																	
Minneapolis	Minneapolis/St. Paul Intl AP	44.88	837	91.0	73.5	-13.4	87.9	72.3	-7.6	76.9	74.9	96.3	-18.6				
St. Cloud	St. Cloud Regional AP	45.55	1024	90.0	72.9	-19.3	86.5	71.2	-12.9	76.5	74.5	95.6	-25.6				
<b>MISSISSIPPI</b>																	
Jackson	Jackson Intl AP	32.32	331	95.6	76.7	22.0	93.6	76.3	25.8	79.8	78.8	98.6	15.2				
Biloxi	Keesler AFB/Biloxi	30.42	26	93.5	80.2	30.3	91.5	79.4	34.9	83.5	82.2	97.0	21.6				
Gulfport	Keesler AFB/Biloxi	30.42	26	93.5	80.2	30.3	91.5	79.4	34.9	83.5	82.2	97.0	21.6				
<b>MISSOURI</b>																	
Columbia	Columbia Regional AP	38.82	899	94.7	76.1	1.3	91.6	75.9	7.1	79.1	77.7	99.3	-5.8				
Kansas City	Kansas City	39.30	1024	96.2	76.3	-0.1	92.7	75.8	5.4	79.5	78.0	100.2	-6.2				
Poplar Bluff	Poplar Bluff (AMOS)	36.77	479	93.8	77.1	9.5	91.5	76.4	15.5	80.2	78.8	98.3	2.9				
St. Louis (JBO)	St. Louis Lambert Intl AP	38.75	709	95.6	76.8	4.1	93.1	76.1	10.2	79.4	78.2	99.9	-1.8				
<b>MONTANA</b>																	
Ft. Harrison	Helena Regional AP	46.61	2868	92.7	61.5	-15.4	89.3	60.7	-8.2	64.5	62.9	98.3	-21.6				

Table 6-1 CLIMATIC CONDITIONS																	
Location	Weather Station	North Latitude	MSL Elevation	Col. 1a 0.4%		Col. 1b 99.6%		Col. 2a 1%		Col. 2b 99%		Col. 3 Wet Bulb		Annual Extreme Daily-Mean Db			
				Temperatures										0.4%	1%	Maximum	Minimum
				Summer		Winter		Summer		Winter							
				Db	Wb	Db	Db	Wb	Db								
Miles City	Miles City Municipal AP	46.43	2635	98.5	65.9	-18.1	94.7	64.9	-	11.5	69.7	68.0	103.6	-24.0			
NEBRASKA																	
Grand Island	Grand Island Central NE Region	40.96	1857	96.2	73.8	-6.1	93.0	73.0	-0.1	77.3	75.6	102.1	-12.4				
Lincoln	Lincoln Co	40.83	1188	97.2	75.1	-5.4	93.7	74.3	0.3	78.2	76.9	102.2	-11.4				
Omaha	Omaha Eppley Airfield	41.31	981	95.0	76.1	-6.3	91.8	75.0	-0.7	79.0	77.3	99.8	-11.8				
NEVADA																	
Las Vegas	Nellis AFB	36.23	1880	109.2	67.6	28.2	107.3	67.1	31.5	72.5	71.2	21.9	113.8				
Reno	Reno Tahoe Intl AP	39.48	4400	95.7	61.9	11.9	93.1	60.7	17.0	64.0	62.4	100.4	5.5				
NEW HAMPSHIRE																	
Manchester*	Manchester AP	42.93	233	91.2	72.1	1.0	88.6	70.8	6.7	75.8	74.1	96.9	-5.8				
NEW JERSEY																	
East Orange	Newark	40.72	30	94.0	74.9	11.0	91.0	73.5	15.5	77.7	76.3	98.9	5.6				
Lyons*	New Brunswick	40	86	92	77	6	89	76	6	-	-	-	-				
NEW MEXICO																	
Albuquerque	Albuquerque	35.04	5315	95.2	60.3	17.7	92.9	60.1	21.2	65.3	64.5	99.4	10.4				

Table 6-1 CLIMATIC CONDITIONS																	
Location	Weather Station	North Latitude	MSL Elevation	Col. 1a 0.4%		Col. 1b 99.6%		Col. 2a 1%		Col. 2b 99%		Col. 3 Wet Bulb		Annual Extreme Daily-Mean Db			
				Temperatures										0.4%	1%	Maximum	Minimum
				Summer		Winter		Summer		Winter							
				Db	Wb	Db	Db	Wb	Db								
NEW YORK																	
Albany	Albany Co AP	42.75	292	89.0	73.0	-1.9	86.1	71.4	2.9	75.8	74.2	93.8	-9.1				
Batavia*	Batavia	43	900	90	75	1	87	73	1	-	-	-	-				
Bath*	Hornell	42	1325	88	74	-4	85	73	-4	-	-	-	-				
Bronx	NYC/John F. Kennedy Intl AP	40.66	23	89.7	73.5	12.8	86.5	72.2	17.2	77.0	75.8	96.1	7.3				
Brooklyn	NYC/John F. Kennedy Intl AP	40.66	23	89.7	73.5	12.8	86.5	72.2	17.2	77.0	75.8	96.1	7.3				
Buffalo	Buffalo Niagara Intl AP	42.94	705	86.5	71.2	2.7	84.0	70.0	6.7	74.8	73.2	90.8	-3.1				
Canandaigua*	Geneva	42	590	90	75	-3	87	73	-3	-	-	-	-				
Castle Point	Poughkeepsie Dutchess Co AP	41.63	161	91.4	74.0	0.5	88.5	72.7	6.0	76.8	75.1	96.2	-8.1				
Montrose*	Newberg-Stewart AFB	41.50	581	89.8	72.5	3.5	86.3	71.7	9.0	76.0	74.3	93.9	-4.1				
New York City	NYC/John F. Kennedy Intl AP	40.66	23	89.7	73.5	12.8	86.5	72.2	17.2	77.0	75.8	96.1	7.3				
Northport*	Suffolk Co AFB	40	57	86	76	7	83	74	7	-	-	-	-				
Syracuse	Syracuse Hancock Intl AP	43.11	417	88.9	73.0	-2.7	86.0	71.2	2.9	75.4	73.7	92.8	-10.5				
St. Albans	Syracuse Hancock Intl AP	43.11	417	88.9	73.0	-2.7	86.0	71.2	2.9	75.4	73.7	92.8	-10.5				



Table 6-1 CLIMATIC CONDITIONS																	
Location	Weather Station	North Latitude	MSL Elevation	Col. 1a 0.4%		Col. 1b 99.6%		Col. 2a 1%		Col. 2b 99%		Col. 3 Wet Bulb		Annual Extreme Daily-Mean Db			
				Temperatures										0.4%	1%	Maximum	Minimum
				Summer		Winter		Summer		Winter							
				Db	Wb	Db	Db	Wb	Db								
<b>NORTH CAROLINA</b>																	
Durham	Raleigh Durham Intl AP	35.87	436	94.1	75.9	18.8	91.7	75.6	23.1	78.3	77.3	97.8	10.6				
Fayetteville	Fort Bragg Simmons AAF	35.13	305	96.6	76.2	21.7	94.0	75.7	26.0	79.2	78.1	100.3	13.3				
Asheville (Oteen)	Asheville Regional AP	35.43	2169	88.2	71.6	13.6	85.8	70.9	18.6	74.2	73.1	91.6	4.6				
Salisbury	Winston-Salem Reynolds AP	36.13	971	92.4	74.5	18.2	90.3	73.9	22.8	40.9	39.8	96.3	9.5				
<b>NORTH DAKOTA</b>																	
Fargo	Fargo Hector Intl AP	46.93	899	91.0	72.1	-20.4	87.7	70.3	-15.2	75.4	73.4	96.9	-24.7				
<b>OHIO</b>																	
Brecksville	Cleveland Hopkins Intl AP	41.41	804	89.4	73.9	2.5	86.7	72.5	8.2	76.3	74.7	93.4	-4.0				
Chillicothe*	Chillicothe	39	638	95	78	0	92	76	0	-	-	-	-				
Cincinnati	Cincinnati Municipal AP Lunki	39.10	499	92.8	74.9	6.3	90.2	74.4	12.4	77.9	76.7	96.2	-1.8				
Cleveland	Cleveland Hopkins Intl AP	41.41	804	89.4	73.9	2.5	86.7	72.5	8.5	76.3	74.7	93.4	-4.0				
Dayton	Dayton Intl AP	39.91	1004	90.3	73.6	0.6	87.9	72.8	6.9	76.5	75.1	93.7	-6.5				
<b>OKLAHOMA</b>																	
Muskogee*	Muskogee	35	610	101	79	10	98	78	10	-	-	-	-				

<b>Table 6-1 CLIMATIC CONDITIONS</b>																	
<b>Location</b>	<b>Weather Station</b>	<b>North Latitude</b>	<b>MSL Elevation</b>	<b>Col. 1a 0.4%</b>		<b>Col. 1b 99.6%</b>		<b>Col. 2a 1%</b>		<b>Col. 2b 99%</b>		<b>Col. 3 Wet Bulb</b>		<b>Annual Extreme Daily-Mean Db</b>			
				<b>Temperatures</b>										<b>0.4%</b>	<b>1%</b>	<b>Maximum</b>	<b>Minimum</b>
				<b>Summer</b>		<b>Winter</b>		<b>Summer</b>		<b>Winter</b>							
				<b>Db</b>	<b>Wb</b>	<b>Db</b>	<b>Db</b>	<b>Wb</b>	<b>Db</b>								
Oklahoma City	Oklahoma City Will Rogers World AP	35.39	1306	99.5	74.1	11.4	96.8	74.1	17.4	77.7	76.7	102.7	6.1				
<b>OREGON</b>																	
Portland	Portland Intl AP	45.59	108	91.2	67.5	23.9	87.1	66.5	28.6	69.4	67.8	99.0	20.5				
Roseburg*	Roseburg AP	43	505	93	69	18	90	67	18	-	-	-	-				
White City	Medford Rogue Valley Intl AP	42.39	1329	98.6	67.2	22.9	95.3	65.9	25.7	69.0	67.5	104.2	18.1				
<b>PENNSYLVANIA</b>																	
Altoona	Altoona Blair Co AP	40.30	1470	88.5	72.0	4.7	85.7	70.7	9.6	74.7	73.2	92.5	-2.6				
Butler*	Butler Co (AWOS)	40.78	1247	88.0	72.4	3.1	84.4	70.6	8.9	74.6	73.0	91.1	-2.3				
Coatesville*	New Castle	41	825	91	75	2	88	74	2	-	-	-	-				
Erie	Erie Intl AP	42.08	738	86.4	72.9	5.2	84.0	71.6	9.7	75.3	73.8	91.5	-0.5				
Lebanon	Harrisburg Capital City AP	40.22	348	92.4	73.8	8.7	89.6	72.5	13.3	76.5	75.2	96.3	1.6				
Philadelphia	Philadelphia Intl AP	39.87	30	93.2	75.4	12.6	90.6	74.5	16.9	78.3	77.0	97.0	6.6				
Pittsburgh	Pittsburgh Intl AP	40.50	1204	89.5	72.5	3.7	86.6	71.1	9.4	75.2	73.7	92.4	-3.0				
Wilkes-Barre	Wilkes-Barre Scranton Intl AP	41.34	961	88.9	72.1	3.5	86.0	70.6	8.3	75.0	73.3	93.0	-2.7				
<b>PUERTO RICO</b>																	
San Juan	San Juan Intl AP	18.42	62	91.4	77.4	69.1	89.6	77.8	70.2	80.6	79.9	93.9	66.8				

Table 6-1 CLIMATIC CONDITIONS																	
Location	Weather Station	North Latitude	MSL Elevation	Col. 1a 0.4%		Col. 1b 99.6%		Col. 2a 1%		Col. 2b 99%		Col. 3 Wet Bulb		Annual Extreme Daily-Mean Db			
				Temperatures										0.4%	1%	Maximum	Minimum
				Summer		Winter		Summer		Winter							
				Db	Wb	Db	Db	Wb	Db								
<b>RHODE ISLAND</b>																	
Providence	Providence/TF Green State	41.72	62	90.1	73.3	7.2	86.7	71.7	11.9	76.5	74.9	95.5	1.4				
<b>SOUTH CAROLINA</b>																	
Charleston	Charleston Intl AP	32.90	49	94.3	78.2	26.9	92.1	77.6	30.4	80.5	79.7	98.5	19.4				
Columbia	Columbia Metro AP	33.94	226	97.0	75.4	22.0	94.5	75.1	25.9	78.4	76.8	100.6	15.0				
<b>SOUTH DAKOTA</b>																	
Ft. Meade	Rapid City Regional AP	44.05	3169	96.9	65.9	-10.5	92.8	65.6	-4.6	71.0	69.3	102.9	-17.3				
Hot Springs	Rapid City Regional AP	44.05	3169	96.9	65.9	-10.5	92.8	65.6	-4.6	71.0	69.3	102.9	-17.3				
Sioux Falls	Sioux Falls Foss Fld	43.58	1427	92.8	74.0	-13.7	89.4	73.3	-8.4	77.4	75.5	98.4	-19.4				
<b>TENNESSEE</b>																	
Memphis	Memphis Intl AP	35.06	331	96.0	77.3	17.0	93.9	76.9	21.7	80.2	79.2	98.6	10.7				
Mountain Home	Bristol-Tri-City AP	36.48	1526	89.8	72.2	11.4	87.5	71.7	16.9	75.0	74.0	92.7	2.3				
Murfreesboro*	Murfreesboro AP	35	608	97	78	9	94	77	9	-	-	-	-				
Nashville	Nashville Intl AP	36.12	604	94.4	75.0	12.9	92.1	74.8	18.2	78.2	77.2	97.4	4.6				

<b>Table 6-1 CLIMATIC CONDITIONS</b>																	
Location	Weather Station	North Latitude	MSL Elevation	Col. 1a 0.4%		Col. 1b 99.6%	Col. 2a 1%		Col. 2b 99%	Col. 3 Wet Bulb		Annual Extreme Daily-Mean Db					
				Temperatures										0.4%	1%	Maximum	Minimum
				Summer		Winter	Summer		Winter								
				Db	Wb	Db	Db	Wb	Db								
<b>TEXAS</b>																	
Amarillo	Amarillo Intl AP	35.22	3606	97.3	66.2	7.2	94.8	66.2	13.7	71.1	70.0	101.2	0.9				
Big Spring*	Big Spring AP	32	2537	100	74	16	97	73	16	-	-	-	-				
Bonham*	Sherman-Perrin AFB	33	763	100	78	15	98	77	15	-	-	-	-				
Dallas	Dallas-Fort Worth Intl AP	32.90	597	100.4	74.5	20.3	98.4	74.6	25.8	78.6	77.8	103.5	15.7				
Houston	Houston Bush InterContinental AP	29.99	105	96.8	76.6	29.1	95.0	76.6	32.9	80.1	88.2	100.2	24.0				
Kerrville	San Antonio Intl AP	29.53	810	98.5	73.5	27.4	96.9	73.6	31.6	78.0	77.3	102.2	21.5				
Marlin	Waco Regional AP	31.61	509	100.8	75.1	22.9	98.9	75.3	27.5	78.7	78.1	104.3	17.6				
San Antonio	San Antonio Intl AP	29.53	810	98.5	73.5	27.4	96.9	73.6	31.6	78.0	77.3	102.2	21.5				
Temple*	Temple	31	675	100	78	22	99	77	22	-	-	-	-				
Waco	Waco Regional AP	31.61	509	100.8	75.1	22.9	98.9	75.3	27.5	78.7	78.1	104.3	17.6				
<b>UTAH</b>																	
Salt Lake City	Salt Lake City Intl AP	40.79	4226	97.4	63.5	9.3	94.8	62.6	14.1	67.0	95.7	101.2	2.6				
<b>VERMONT</b>																	
White River Junction	Montpelier AP	44.20	1122	85.1	69.9	-10.7	82.3	68.2	-6	72.6	70.7	89.8	-18.3				

Table 6-1 CLIMATIC CONDITIONS																	
Location	Weather Station	North Latitude	MSL Elevation	Col. 1a 0.4%		Col. 1b 99.6%		Col. 2a 1%		Col. 2b 99%		Col. 3 Wet Bulb		Annual Extreme Daily-Mean Db			
				Temperatures										0.4%	1%	Maximum	Minimum
				Summer		Winter		Summer		Winter							
				Db	Wb	Db	Db	Wb	Db								
<b>VIRGINIA</b>																	
Hampton	Norfolk Intl AP	36.90	30	93.7	76.7	21.7	91.3	76.0	25.6	79.0	78.0	98.0	15.6				
Richmond	Dinwiddie Co	37.18	197	97.4	77.8	15.9	94.7	76.7	19.2	80.9	79.4	100.5	6.2				
Salem	Roanoke Regional AP	37.32	1175	92.1	72.9	14.2	89.8	72.4	19.0	75.4	74.5	96.0	6.3				
<b>WASHINGTON</b>																	
American Lake	Olympia AP	46.97	200	87.3	66.0	20.1	83.3	64.8	24.1	67.8	65.9	95.2	12.5				
Seattle	Seattle-Tacoma Intl AP	47.46	433	84.9	65.0	24.5	81.3	63.6	29.1	66.5	64.8	92.4	20.7				
Spokane	Fairchild AFB	47.62	2438	91.4	62.2	4.6	88.5	61.5	10.6	64.9	63.3	96.8	-1.7				
Vancouver	Portland Intl AP	45.59	108	91.2	67.5	23.9	87.1	66.5	28.6	69.4	67.8	99	20.5				
Walla Walla	Walla Walla City Co AP	46.10	1204	98.9	66.8	8.1	94.9	65.5	16.2	68.8	67.0	105.0	6.3				
<b>WEST VIRGINIA</b>																	
Beckley*	Beckley Raleigh Co MEM AP	37.80	2513	84.6	69.8	5.5	82.4	69.1	11.4	72.5	71.3	87.8	-3.4				
Clarksburg*	Clarksburg	39	977	92	76	6	90	75	6	-	-	-	-				
Huntington	Huntington Tri-State AP	38.38	837	91.9	73.8	8.4	89.4	73.5	14.6	77.3	76.0	95.0	-0.4				
Martinsburg	Martinsburg Eastern WV Regional AP	39.40	535	93.3	73.9	9.7	90.4	73.1	14.6	77.0	75.6	97.6	-0.3				

<b>Table 6-1 CLIMATIC CONDITIONS</b>																	
Location	Weather Station	North Latitude	MSL Elevation	Col. 1a 0.4%		Col. 1b 99.6%	Col. 2a 1%		Col. 2b 99%	Col. 3 Wet Bulb		Annual Extreme Daily-Mean Db					
				Temperatures										0.4%	1%	Maximum	Minimum
				Summer		Winter	Summer		Winter								
				Db	Wb	Db	Db	Wb	Db								
<b>WISCONSIN</b>																	
Madison	Madison Dane Co Regional AP	43.14	866	89.8	74.4	-9.1	86.8	72.8	-2.9	77.1	75.0	94.2	-15.3				
Tomah	La Crosse Municipal AP	43.75	656	92.1	75.1	-12.3	89.0	73.5	-5.8	78.0	75.9	98.0	-16.8				
Wood	Milwaukee Mitchell Intl AP	42.95	692	90.3	74.6	-4.0	86.8	72.6	1.8	77.0	75.0	95.9	-10.3				
<b>WYOMING</b>																	
Cheyenne	Cheyenne Municipal AP	41.16	6142	89.2	58.6	-6.4	86.3	58.0	1.7	63.0	31.8	93.7	-14.8				
Sheridan	Sheridan Co AP	44.77	3967	95.5	63.8	-12.7	92.1	63.0	-6.1	67.5	65.7	100.8	-20.3				

**NOTES:**

- The climatic conditions table data is based on the 2009 ASHRAE Handbook of Fundamentals and the 1978 Department of Defense Engineering Weather Data (denoted by asterisk). Use column 1a and 1b for design.

<b>Table 6-2 HIGH HUMIDITY LOCATIONS</b>	
<b>Dew-Point Temperature &gt; 60 F [15.6 C]</b>	
<b>For a Minimum of 4000 hours/year</b>	
<b>Data Based on 5-Year Averages</b>	
<b>Locations</b>	<b>Annual Dew-Point Hours</b>
Bay Pines	5406
Biloxi	4114
Charleston	4368
Gainesville	4774
Honolulu	7951
Houston	5152
Lake City	4774
Miami	7020
New Orleans	5104
Orlando	5703
Panama City	5037
Pensacola	4838
San Juan	8474
Tampa	5788
Viera	6025
West Palm Beach	6606

<b>Table 6-3 LOW HUMIDITY LOCATIONS</b> <b>Dew-Point Temperature &lt; 35 F [1.7 C]</b> <b>For a Minimum of 3500 hours/year</b> <b>Data Based on 5-Year Averages</b>	
<b>Locations</b>	<b>Annual Dew-Point Hours</b>
Albuquerque	5211
Anchorage	4947
Cheyenne	5556
Denver	5115
Fargo	4099
Las Vegas	5083
Phoenix	3674
Minneapolis	3893
Tucson	4063

**Note:** Calculate and compare humidification loads in the cooling and heating modes of the system operation. Size and select the humidification equipment based on the higher value.



INDEX

A/E	1-3	cooling systems	4-2
A/E quality alerts	1-7	air-cooled chillers	4-2
A/E review checklist	1-6	central chilled water plants	4-2
acoustic analysis	2-8	dedicated chilled water systems	4-2
air balance	2-4	cooling towers	2-9, 4-6, 5-7
air intakes	2-14	cost estimating manual	1-8
air terminal units	3-17	CV air terminal unit	5-6
air-cooled chillers	4-2	CV systems	3-6
AIR-HANDLING UNIT DATA SHEETS		economizer cycle	3-7
Atrium	3-20	DDC sensors	3-9
Auditoriums and Theaters	3-21	DDC systems	5-4
Gymnasium	3-22	demolition	2-14
Home and Community Center	3-23	design alerts	1-7
Kitchen	3-24	design guides	1-7
Minimum Ventilation Air	3-26	design manuals	1-5
Standalone Smoking Facility	3-27	design review checklist	1-6
air-handling units		dew-point hours	
common	3-19	high humidity areas	6-17
components	3-6	low humidity areas	6-18
dedicated	3-19	direct expansion systems	4-7
modes	5-5	dispersion analysis	2-10
selection	3-18	DOE	1-5
airside controls	5-5	Domiciliary	1-2
all-air systems	See central air-handling units	ductwork	
ASHRAE STANDARD 90.1 – 2007	1-3	duct materials	3-16
BACnet	5-2	duct pressure classification	3-17
CAD standards	1-8	existing	2-13
calculations		exposed ductwork	3-17
cooling and heating loads	2-3, 2-6	flexible duct	3-16
central air-handling units	3-6	minimum duct size	3-16
chilled water systems	4-2	sizing criteria	3-17
controls	5-7	DX systems	See direct expansion systems
dedicated chilled water systems	4-2	electric coils	3-8
primary secondary system	4-4	electrical heating systems	4-10
climatic conditions	6-2	energy conservation	1-3, 4-5
commissioning	1-5	mandated measures	1-3
common air-handling units	3-19	ENERGY STAR®	1-4
community center		equipment schedules	1-10
miscellaneous spaces	1-2	exhaust fans	3-7, 3-15
optional spaces	1-2	exhaust systems	
community living center		components	3-15
community center	1-2	dedicated	3-15
home	1-2	general	3-15
condenser water system	4-6	special, grease exhaust	3-15
control actuators	5-3	special, wet exhaust	3-16
control dampers	5-3	existing buildings	
control valves	5-3	as-built drawings	2-12
cooling and heating loads	2-3	design considerations	2-12
cooling coils	3-7	site visits	2-13

## HVAC Design Manual

fan coil unit control	5-6	Bistro	3-29
fan coil units	2-9, 3-11	Chapel/Meditation	3-29
filters	3-9	Clean Linen Closet	3-37
air filter	3-8	Communications Closet, Satellite Telephone	3-31
water filter	4-6	Concierge Station	3-29
fire and smoke protection	2-11	Conference Room	3-29
gas heating systems	4-10	Copy Room	3-29
glycol	4A-1	Corridor	3-38
chilled water systems	4-7	Crawl Space (Pipe Basement)	3-32
coils	3-8	Den	3-38
hydronic hot water systems	4-9	Dining Room	3-38
glycol correction factor	4A-3	Electrical Equipment Rooms	3-33
ground source heat pumps	3-11, 5-6	Entry, Home	3-39
heat recovery systems	3-14, 5-6	Examination Room	3-36
heat transfer	3-14	Exterior Stairs	3-33
heating and ventilation systems	3-13	Foyer	3-38
heating systems	4-8	Garage, Community Center	3-29
controls	5-6	Garage, Home	3-38
electrical	4-10	Great Room	3-30
gas	4-10	HAC	3-30, 3-38
geothermal	4-11	Hair Care (Barber/Beauty), Community Center	3-30
hydronic	4-8	Hair Care (Barber/Beauty), Home	3-38
steam	4-8	Kitchen Housekeeping Closet	3-39
hot water coils	3-8	Kitchen, Home	3-39
humidifiers	3-9	Laundry, Home	3-39
humidity control	5-6	Living Room	3-39
HVAC systems	3-5	Lounge and Lockers, Staff	3-31
hydronic heating systems	4-8	Mechanical Equipment Rooms	3-34
indoor design conditions	2-3	Media Center	3-30
life-cycle cost analysis	1-4	Multi-Purpose Room	3-30
measurement and verification	1-4	Office, Home	3-39
outdoor air	3-13	Offices	3-30
pipng	4-11	Pharmacy	3-36
plenum fans	3-6	Physician Office	3-36
point lists	5-8	Receiving/Loading	3-36
point schedule	5-8	Refrigeration Equipment Rooms	3-35
preheat coils	3-8	Security Office	3-36
primary secondary system	4-4	Soiled Utility Room	3-40
propylene glycol	See glycol correction factor	Storage	3-31
PRV station	4-13	Storage, Home	3-39
psychrometric analysis	2-7	Toilet and Showers, Resident	3-40
RDS	See Room Data Sheets	Toilet, Public	3-40
refrigeration systems		Toilet, Special Care Resident	3-40
components	4-2	Toilet, Staff	3-31
minimum performance compliance	4-3	Toilets, Public	3-30
reheat coils	3-8	Vestibule	3-31
requirements for A/E submissions	1-6	room temperature controls	2-7
room air balance	2-4	seismic requirements	2-10
<b>ROOM DATA SHEETS</b>		selection parameters	
Attic Space	3-32	cooling tower	2-3
Bathing Suite	3-37	ground source heat pumps	3-12
Bedroom, Resident	3-37		
Bedroom, Special Care Resident	3-37		

## INDEX

preheat coil	2-3	steam traps	4-14
solid separator	4-7	terminal heating and cooling systems	3-10
sound attenuators	2-9	VA standards	1-5
special exhaust systems	5-6	variable air volume systems	3-10
specifications, master	1-6	variable speed drive	3-10, 4-6
standard details	1-8	VAV systems	3-10
steam heating coils	3-8	vibration control	2-10
steam piping	4-12	water treatment systems	4-6
steam reheat coils	4-14		

