

LUMINAIRE REQUIREMENTS:

1. HOUSING – DIE CAST ALUMINUM OR DIE CAST AND EXTRUDED ALUMINUM. HEAT SINK INCORPORATED DIRECTLY INTO HOUSING TO ENSURE MAXIMUM HEAT TRANSFER AND DISSIPATION.
2. FINISH – MULTI-STAGE PRE-TREATMENT, FINISHED WITH BAKED-ON POLYESTER POWDER COAT. FINISH SHALL PASS 2500 HOUR SALT SPRAY TEST PER ASTM B117. FINISH COLORS INCLUDE DARK BRONZE, SILVER, OR BLACK WITH CUSTOM COLORS AVAILABLE.
3. POWER SUPPLY/LED DRIVER – PROVIDE IN SEPARATE COMPARTMENT ACCESSIBLE WITHOUT THE USE OF HAND TOOLS. CLASS 1 DRIVER SHALL OPERATE AT 120/277 V, 50/60 Hz. OTHER VOLTAGES OPTIONAL. POWER FACTOR GREATER THAN 0.9 AND THD LESS THAN 20% AT FULL LOAD. MINIMUM EFFICACY SHALL BE 60 LM/W AT MAXIMUM 600 mA OPERATING CURRENT.
4. LED OPTICAL ASSEMBLY – NUMBER OF LED ARRAYS SHALL VARY TO ACCOMMODATE DESIRED LUMINAIRE OUTPUT. PROVIDE WITH EQUIVALENT NEMA TYPE II, III IV, OR V DISTRIBUTION AS INDICATED. BUG UPLIGHT RATING OF U0, WITH BACKLIGHT AND GLARE RATINGS AS DETERMINED BY LIGHTING ZONE INSTALLED. MINIMUM COLOR RENDERING INDEX (CRI) SHALL BE 70 FOR CORRELATED COLOR TEMPERATURES (CCT) OF 4000–4500 DEGREES K.
5. SURGE PROTECTION – 6 kV MINIMUM, COMPLIANT WITH ANSI C62.41.2.
6. CERTIFICATION – UL AND/OR ETL LISTED, MINIMUM IP65 RATED PER ANSI/IEC 60529, AND RoHS COMPLIANT.
7. OPTIONS – PHOTOCELL AND RECEPTACLE, SHORTING CAP, BIRD SPIKES, AND 0–10 VOLT DIMMING DRIVER.
8. OTHER – THE ABOVE SKETCH IS A NON-PROPRIETARY GRAPHIC REPRESENTATION OF A LUMINAIRE THAT MAY MEET THE SPECIFICATION REQUIREMENTS AND IS NOT INTENDED TO INDICATE A CERTAIN MANUFACTURER’S PREFERENCE. ALL DIMENSIONS ARE NOMINAL AND VARY PER MANUFACTURER.

LED ROADWAY LUMINAIRE

REVISED:

MARCH 2013

LUMINAIRE PLATE:

XL-01

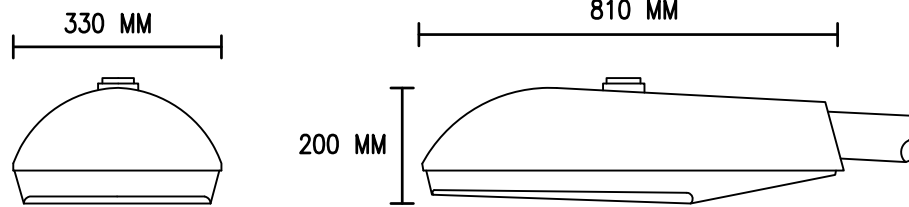

LUMINAIRE REQUIREMENTS:

1. HOUSING – DIE CAST OR EXTRUDED ALUMINUM. BAIL LATCH AND ALL HARDWARE SHALL BE STAINLESS STEEL.
2. FINISH – MULTI-STAGE PRE-TREATMENT, FINISHED WITH BAKED-ON POLYESTER POWDER COAT. FINISH SHALL PASS 2500 HOUR SALT SPRAY TEST PER ASTM B117. TYPICAL FINISHES INCLUDE GREY OR SILVER WITH ADDITIONAL CUSTOM COLORS AVAILABLE.
3. REFLECTOR/LENS – ONE-PIECE ANODIZED SPECULAR OR SEMI-SPECULAR ALUMINUM PRODUCING NEMA DISTRIBUTION TYPE II, III OR IV AS INDICATED. BUG UPLIGHT RATING SHALL BE U0, WITH BACKLIGHT AND GLARE RATINGS AS DETERMINED BY LIGHTING ZONE INSTALLED. LENS SHALL BE FLAT, CLEAR, TEMPERED GLASS WITH POLYCARBONATE VANDAL-RESISTANT OPTION.
4. BALLAST/HF GENERATOR – PREWIRED TO SEPARATE MOUNTING ASSEMBLY WITH QUICK DISCONNECT PLUGS. METAL HALIDE BALLAST SHALL BE HIGH POWER FACTOR (≥ 0.9), ENCAPSULATED, CONSTANT WATTAGE AUTOTRANSFORMER, CORE AND COIL TYPE WITH MINIMUM STARTING TEMPERATURE OF MINUS 30 DEGREE C. PROVIDE PULSE START TYPE AS INDICATED AND WHEN AVAILABLE. FOR INDUCTION SOURCE, PROVIDE GENERATOR SPECIFICALLY DESIGNED TO OPERATE EITHER "QL" OR "ICETRON" TYPE LIGHT SOURCE OF WATTAGE SPECIFIED.
5. LIGHT SOURCE – METAL HALIDE OR INDUCTION SOURCE IN WATTAGE INDICATED. METAL HALIDE SOCKET SHALL BE PORCELAIN WITH NICKEL-PLATED SCREW AND CENTER CONTACT.
6. CERTIFICATION – UL AND/OR ETL LISTED AND RoHS COMPLIANT.
7. OPTIONS – PHOTOCCELL AND/OR RECEPTACLE, SHORTING CAP, IN-LINE FUSING, AND HOUSE SIDE SHIELDING.
8. MOUNTING – ADJUSTABLE SLIPFITTER FOR 32 MM TO 50 MM MAST ARM.
9. OTHER – THE ABOVE SKETCH IS A NON-PROPRIETARY GRAPHIC REPRESENTATION OF A LUMINAIRE THAT MAY MEET THE SPECIFICATION REQUIREMENTS AND IS NOT INTENDED TO INDICATE A CERTAIN MANUFACTURER'S PREFERENCE. ALL DIMENSIONS ARE NOMINAL AND VARY PER MANUFACTURER.

HID/INDUCTION ROADWAY LUMINAIRE

REVISED:

MARCH 2013

LUMINAIRE PLATE:

XL-02

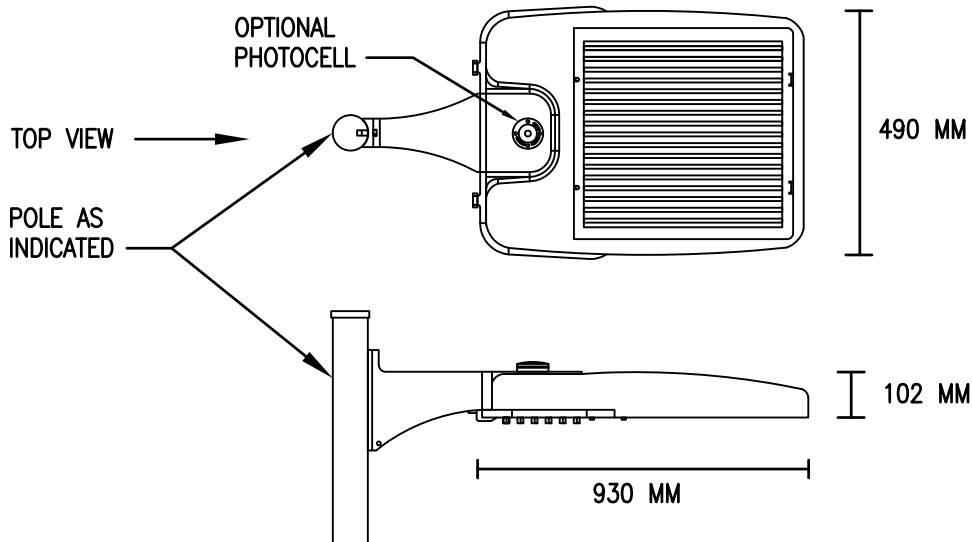

LUMINAIRE REQUIREMENTS:

1. HOUSING – DIE-CAST ALUMINUM OR DIE-CAST AND EXTRUDED ALUMINUM WITH INTEGRAL, SELF-CLEANING HEAT SINK FINS, RIBS, OR EQUIVALENT PASSIVE COOLING MECHANISM. HEAT SINK SHALL BE INCORPORATED DIRECTLY INTO HOUSING TO ENSURE MAXIMUM HEAT TRANSFER AND DISSIPATION.
2. FINISH – MULTI-STAGE PRE-TREATMENT, FINISHED WITH BAKED-ON POLYESTER POWDER COAT. FINISH SHALL PASS 2500 HOUR SALT SPRAY TEST PER ASTM B117. FINISH COLORS INCLUDE DARK BRONZE, SILVER, OR BLACK WITH CUSTOM COLORS AVAILABLE.
3. POWER SUPPLY/LED DRIVER – PROVIDE IN SEPARATE COMPARTMENT ACCESSIBLE WITHOUT THE USE OF HAND TOOLS. CLASS 1 DRIVER SHALL OPERATE AT 120/277V, 50/60 HZ; OTHER VOLTAGES OPTIONAL. POWER FACTOR GREATER THAN 0.9 AND THD LESS THAN 20% AT FULL LOAD. MINIMUM EFFICACY SHALL BE 60 LM/W AT MAXIMUM 600 mA OPERATING CURRENT.
4. LED OPTICAL ASSEMBLY – NUMBER OF LED ARRAYS SHALL VARY TO ACCOMMODATE DESIRED LUMINAIRE OUTPUT. PROVIDE WITH EQUIVALENT NEMA TYPE III, IV OR V DISTRIBUTION AS INDICATED. BUG UPLIGHT RATING OF U0, WITH BACKLIGHT AND GLARE RATINGS AS DETERMINED BY LIGHTING ZONE INSTALLED. MINIMUM COLOR RENDERING INDEX (CRI) SHALL BE 70 FOR CORRELATED COLOR TEMPERATURE (CCT) OF 4000-4500 DEGREES K.
5. SURGE PROTECTION – 6 kV MINIMUM, COMPLIANT WITH ANSI C62.41.2.
6. CERTIFICATION – UL AND/OR ETL LISTED, MINIMUM IP65 RATED PER ANSI/IEC 60529, AND RoHS COMPLIANT.
7. OPTIONS – PHOTOCELL AND RECEPTACLE, SHORTING CAP, BIRD SPIKES, AND 0-10 VOLT DIMMING DRIVER.
8. OTHER – THE ABOVE SKETCH IS A NON-PROPRIETARY GRAPHIC REPRESENTATION OF A LUMINAIRE THAT MAY MEET THE SPECIFICATION REQUIREMENTS AND IS NOT INTENDED TO INDICATE A CERTAIN MANUFACTURER'S PREFERENCE. ALL DIMENSIONS ARE NOMINAL AND VARY PER MANUFACTURER.

LED AREA LUMINAIRE

REVISED:

MARCH 2013

LUMINAIRE PLATE:

XL-03

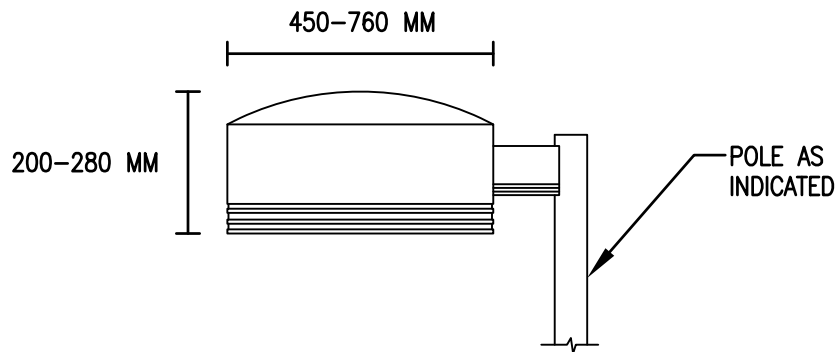

LUMINAIRE REQUIREMENTS:

1. HOUSING – ONE-PIECE EXTRUDED ALUMINUM, FABRICATED SHEET OR SPUN ALUMINUM, OR A COMBINATION OF BOTH AS INDICATED. INTERNALLY WELD AND SEAL ALL CORNERS AND SEAMS OF HOUSING TO RESIST MOISTURE AND DUST.
2. FINISH – MULTI-STAGE PRE-TREATMENT, FINISHED WITH BAKED-ON POLYESTER POWDER COAT. FINISH SHALL PASS 2500 HOUR SALT SPRAY TEST PER ASTM B117. DARK BRONZE FINISH COLOR IS STANDARD; BLACK, WHITE, GRAY AND NATURAL ALUMINUM ALSO AVAILABLE.
3. REFLECTOR – ONE-PIECE, HYDROFORMED OR SEGMENTED, ANODIZED, SPECULAR ALUMINUM; INTERCHANGEABLE AND ROTABLE IN HOUSING PRODUCING NEMA DISTRIBUTION PATTERN II, III, IV OR V AS INDICATED. BUG UPLIGHT RATING SHALL BE U0, WITH BACKLIGHT AND GLARE RATINGS AS DETERMINED BY LIGHTING ZONE INSTALLED.
4. LENS AND FRAME – EXTRUDED, ANODIZED ALUMINUM FRAME WITH ONE-PIECE MOLDED, HIGH TEMPERATURE SILICONE OR NEOPRENE GASKET. LENS SHALL BE TEMPERED GLASS WITH POLYCARBONATE, VANDAL-RESISTANT OPTION. FRAME SHALL BE HINGED AT ONE END AND BE PROVIDED WITH LATCHES FOR SECURING WITHOUT THE NEED FOR TOOLS.
5. LIGHT SOURCE – METAL HALIDE IN WATTAGE AND TYPE AS INDICATED. SEE SPECIFICATIONS OR LUMINAIRE SCHEDULE FOR LIGHT SOURCE SPECIFICS.
6. BALLAST – PREWIRED TO SEPARATE MOUNTING ASSEMBLY WITH QUICK DISCONNECT PLUGS. BALLAST SHALL BE HIGH POWER FACTOR (≥ 0.9), ENCASED AND POTTED (ENCAPSULATED), CONSTANT-WATTAGE AUTOTRANSFORMER, CORE AND COIL TYPE WITH MINIMUM STARTING TEMPERATURE OF MINUS 30 DEGREES C. PROVIDED PULSE START TYPE AS INDICATED AND WHEN AVAILABLE.
7. CERTIFICATION – UL AND/OR ETL LISTED FOR WET LOCATIONS.
8. OPTIONS – HOUSE-SIDE SHIELD, PHOTOCCELL AND RECEPTACLE, SHORTING CAP, SQUARE HOUSING, CUSTOM COLOR AND FUSING.
9. OTHER – THE ABOVE SKETCH IS A NON-PROPRIETARY GRAPHIC REPRESENTATION OF A LUMINAIRE THAT MAY MEET THE SPECIFICATION REQUIREMENTS AND IS NOT INTENDED TO INDICATE A CERTAIN MANUFACTURER'S PREFERENCE. ALL DIMENSIONS ARE NOMINAL AND VARY PER MANUFACTURER.

HID AREA LUMINAIRE

REVISED:

MARCH 2013

LUMINAIRE PLATE:

XL-04

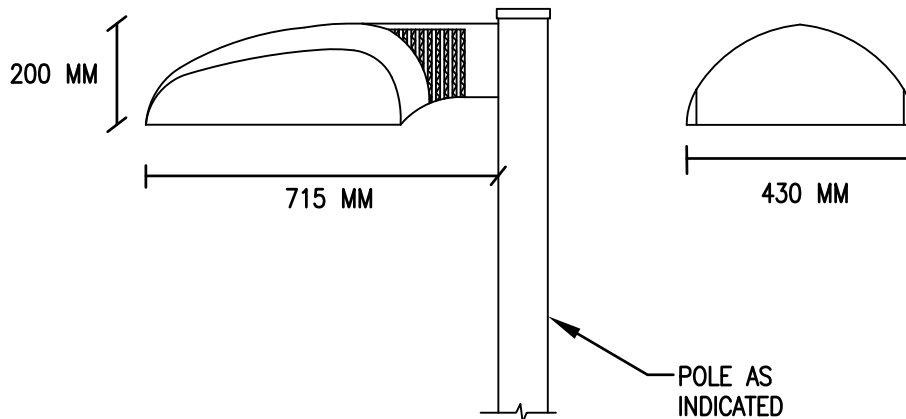

LUMINAIRE REQUIREMENTS:

1. HOUSING – EXTRUDED, DIE-CAST OR FABRICATED ALUMINUM. INTERNALLY WELD AND SEAL ALL CORNERS AND SEAMS OF HOUSING TO RESIST MOISTURE AND DUST.
2. FINISH – MULTI-STAGE PRE-TREATMENT, FINISHED WITH BAKED-ON POLYESTER POWDER COAT. FINISH SHALL PASS 2500 HOUR SALT SPRAY TEST FOR CORROSION RESISTANCE. DARK BRONZE FINISH COLOR IS STANDARD; BLACK, WHITE, GRAY AND NATURAL ALUMINUM ALSO AVAILABLE.
3. REFLECTOR – ONE PIECE, HYDROFORMED OR SEGMENTED, MULTI-FACETED, ANODIZED, SPECULAR ALUMINUM. PROVIDE WITH NEMA DISTRIBUTION PATTERN TYPE III OR V AS INDICATED. BUG UPLIGHT RATING SHALL BE U0, WITH BACKLIGHT AND GLARE RATINGS AS DETERMINED BY LIGHTING ZONE INSTALLED.
4. LENS AND FRAME– EXTRUDED OR DIE-CAST ALUMINUM FRAME WITH ONE-PIECE MOLDED, HIGH TEMPERATURE SILICONE OR NEOPRENE GASKET. LENS SHALL BE TEMPERED GLASS WITH POLYCARBONATE, VANDAL-RESISTANT OPTION. FRAME SHALL BE HINGED AT ONE END AND BE PROVIDED WITH LATCHES FOR SECURING WITHOUT THE NEED FOR TOOLS.
5. LIGHT SOURCE – PHOSPHOR-COATED GLASS VESSEL, IN OUTPUT RANGES FROM 40-70, 70-100 OR 150-165 WATTS. SEE LUMINAIRE SCHEDULE FOR LIGHT SOURCE SPECIFICS.
6. HIGH FREQUENCY GENERATOR – PROVIDE WITH QUICK DISCONNECT PLUGS. OPERATING VOLTAGE SHALL BE 120/277 VOLTS WITH 480 VOLT OPTION.
7. CERTIFICATION – UL AND/OR ETL LISTED FOR WET LOCATIONS.
8. OPTIONS – HOUSE SIDE SHIELD, PHOTOCELL AND RECEPTACLE, SHORTING CAP, CUSTOM COLOR AND FUSING.
9. OTHER – THE ABOVE SKETCH IS A NON-PROPRIETARY GRAPHIC REPRESENTATION OF A LUMINAIRE THAT MAY MEET THE SPECIFICATION REQUIREMENTS AND IS NOT INTENDED TO INDICATE A CERTAIN MANUFACTURER’S PREFERENCE. ALL DIMENSIONS ARE NOMINAL AND VARY PER MANUFACTURER.

INDUCTION AREA LUMINAIRE

REVISED:

MARCH 2013

LUMINAIRE PLATE:

XL-05

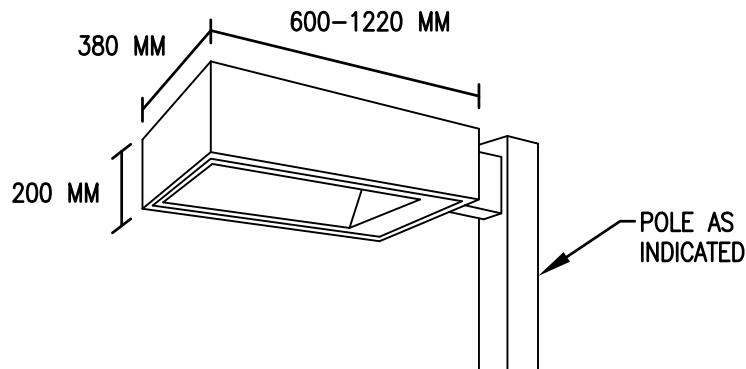

LUMINAIRE REQUIREMENTS:

1. HOUSING – EXTRUDED, DIE-CAST OR FABRICATED ALUMINUM. INTERNALLY WELD AND SEAL ALL CORNERS AND SEAMS OF HOUSING TO RESIST MOISTURE AND DUST.
2. FINISH – MULTI-STAGE PRE-TREATMENT, FINISHED WITH BAKED-ON POLYESTER POWDER COAT. FINISH SHALL PASS 2500 HOUR SALT SPRAY TEST PER ASTM B117. DARK BRONZE FINISH COLOR IS STANDARD; BLACK, WHITE, GREY AND NATURAL ALUMINUM ALSO AVAILABLE.
3. REFLECTOR – ONE PIECE, MULTI-FACETED, ANODIZED, SPECULAR OR SEMI-SPECULAR ALUMINUM; PRODUCING NEMA DISTRIBUTION PATTERN I, II, III, IV OR V AS INDICATED. BUG UPLIGHT RATING SHALL BE U0, WITH BACKLIGHT AND GLARE RATINGS AS DETERMINED BY LIGHTING ZONE INSTALLED.
4. LENS AND FRAME – EXTRUDED OR DIE-CAST, ANODIZED ALUMINUM FRAME WITH ONE-PIECE MOLDED, HIGH TEMPERATURE SILICONE OR NEOPRENE GASKET. LENS SHALL BE TEMPERED GLASS WITH POLYCARBONATE, VANDAL-RESISTANT OPTION. FRAME SHALL BE HINGED AT ONE END AND BE PROVIDED WITH LATCHES FOR SECURING WITHOUT THE NEED FOR HAND TOOLS.
5. LIGHT SOURCE – LOW PRESSURE SODIUM, DC BAYONET BASE, T17/T21 ENVELOPE WITH WATTAGE AS INDICATED. SEE SPECIFICATIONS OR LUMINAIRE SCHEDULE FOR LIGHT SOURCE SPECIFICS.
6. BALLAST – PREWIRED TO SEPARATE MOUNTING ASSEMBLY WITH QUICK DISCONNECT PLUGS. BALLAST SHALL BE HIGH REACTANCE/HIGH POWER FACTOR (≥ 0.9), ENCASED AND POTTED (ENCAPSULATED), CONSTANT WATTAGE AUTOTRANSFORMER, CORE AND COIL, TYPE. PROVIDE NON-PCB, DRY TYPE STARTING CAPACITOR.
7. CERTIFICATION – UL AND/OR ETL LISTED AND RoHS COMPLIANT.
8. OPTIONS – PHOTOCELL RECEPTACLE ONLY, TWIST LOCK PHOTOCELL, SHORTING CAP, HOUSE SIDE SHIELD, AND FUSING.
9. OTHER – THE ABOVE SKETCH IS A NON-PROPRIETARY GRAPHIC REPRESENTATION OF A LUMINAIRE THAT MAY MEET THE SPECIFICATION REQUIREMENTS AND IS NOT INTENDED TO INDICATE A CERTAIN MANUFACTURER'S PREFERENCE. ALL DIMENSIONS ARE NOMINAL AND VARY PER MANUFACTURER.

LOW PRESSURE SODIUM AREA LUMINAIRE

REVISED:

MARCH 2013

LUMINAIRE PLATE:

XL-06

DIE-CAST
BALLAST
COMPARTMENT

SEALED OPTICAL
ASSEMBLY WITH
ALUMINUM
COVER

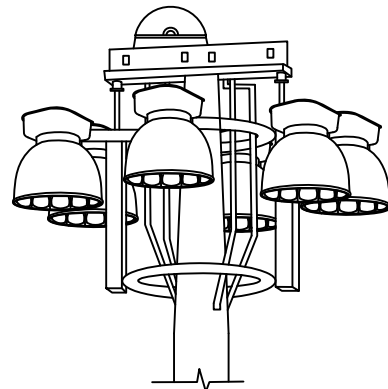
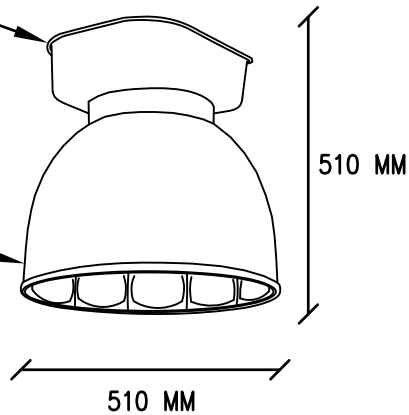

TYPICAL INSTALLATION
SHOWN

LUMINAIRE REQUIREMENTS:

1. HOUSING – ONE-PIECE DIE CAST ALUMINUM. ALL HARDWARE SHALL BE STAINLESS STEEL.
2. FINISH – MULTI-STAGE PRE-TREATMENT, FINISHED WITH BAKED-ON POLYESTER POWDER COAT. FINISH SHALL PASS 2500 HOUR SALT SPRAY TEST PER ASTM B117.
3. REFLECTOR – ONE-PIECE ANODIZED, SPECULAR ALUMINUM SEALED BETWEEN A BOROSILICATE GLASS INNER ENVELOPE AND OUTER SPUN ALUMINUM HOUSING. SHALL PRODUCE A SYMMETRICAL OR ASYMMETRICAL OUTPUT WITH NEMA DISTRIBUTION PATTERN AS INDICATED.
4. LIGHT SOURCE – METAL HALIDE IN WATTAGE AND TYPE AS INDICATED; TYPICALLY 1000-1500 WATTS.
5. BALLAST – PREWIRED IN SEPARATE HOUSING WITH QUICK DISCONNECT PLUGS. BALLAST SHALL BE HIGH POWER FACTOR (≥ 0.9), ENCASED AND POTTED (ENCAPSULATED), CONSTANT WATTAGE AUTOTRANSFORMER, CORE AND COIL TYPE WITH MINIMUM STARTING TEMPERATURE OF MINUS 30 DEGREES C.
6. CERTIFICATION – UL AND/ OR ETL LISTED FOR WET LOCATIONS.
7. OPTIONS – PHOTOCCELL AND RECEPTACLE, NEMA DISTRIBUTION TYPE, AND FUSING.
8. OTHER – THE ABOVE SKETCH IS A NON-PROPRIETARY GRAPHIC REPRESENTATION OF A LUMINAIRE THAT MAY MEET THE SPECIFICATION REQUIREMENTS AND IS NOT INTENDED TO INDICATE A CERTAIN MANUFACTURER'S PREFERENCE. ALL DIMENSIONS ARE NOMINAL AND VARY PER MANUFACTURER.

HID HIGH MAST LUMINAIRE

REVISED:

MARCH 2013

LUMINAIRE PLATE:

XL-07

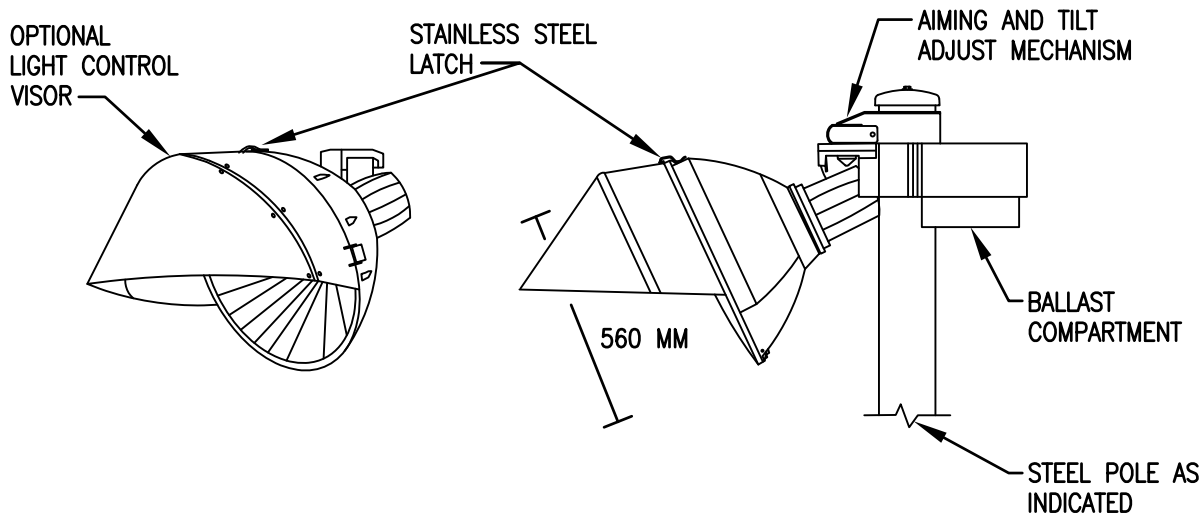

LUMINAIRE REQUIREMENTS:

1. HOUSING – DIE CAST ALUMINUM HOUSING, MOUNTING PLATE, AND AIMING KNUCKLE. ALL HARDWARE SHALL BE STAINLESS STEEL OR ALUMINUM.
2. FINISH – MULTI-STAGE PRE-TREATMENT, FINISHED WITH BAKED-ON POLYESTER POWDER COAT. FINISH SHALL PASS 2500 HOUR SALT SPRAY TEST PER ASTM B117.
3. REFLECTOR – ONE-PIECE, HYDROFORMED OR SEGMENTED, ANODIZED, SPECULAR ALUMINUM.
4. LENS AND FRAME – DIE CAST, ANODIZED ALUMINUM FRAME WITH ONE-PIECE MOLDED, HIGH TEMPERATURE SILICONE OR NEOPRENE GASKET. LENS SHALL BE TEMPERED GLASS. FRAME SHALL BE HINGED AT ONE END AND BE PROVIDED WITH LATCHES FOR SECURING WITHOUT THE NEED FOR TOOLS.
5. LIGHT SOURCE – METAL HALIDE IN WATTAGE AND TYPE AS INDICATED.
6. BALLAST – PREWIRED TO SEPARATE MOUNTING ASSEMBLY WITH QUICK DISCONNECT PLUGS. BALLAST SHALL BE HIGH POWER FACTOR (≥ 0.9), ENCASED AND POTTED (ENCAPSULATED), CONSTANT-WATTAGE AUTOTRANSFORMER, CORE AND COIL TYPE WITH MINIMUM STARTING TEMPERATURE OF MINUS 30 DEGREES C.
7. CERTIFICATION – UL AND/OR ETL LISTED FOR WET LOCATIONS.
8. OPTIONS – NEMA DISTRIBUTION TYPE, EXTERNAL VISOR, INTERNAL LOUVER, REMOTE BALLAST, AND FUSING.
9. OTHER – THE ABOVE SKETCH IS A NON-PROPRIETARY GRAPHIC REPRESENTATION OF A LUMINAIRE THAT MAY MEET THE SPECIFICATION REQUIREMENTS AND IS NOT INTENDED TO INDICATE A CERTAIN MANUFACTURER'S PREFERENCE. ALL DIMENSIONS ARE NOMINAL AND VARY PER MANUFACTURER.

HID APRON/LARGE SPORTS FIELD LUMINAIRE

REVISED:

MARCH 2013

LUMINAIRE PLATE:

XL-08

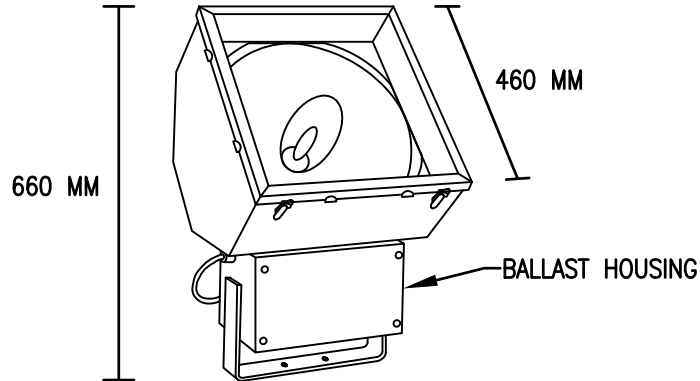

LUMINAIRE REQUIREMENTS:

1. HOUSING – DIE CAST ALUMINUM BALLAST AND REFLECTOR HOUSING. ALL HARDWARE SHALL BE STAINLESS STEEL OR ALUMINUM.
2. FINISH – MULTI-STAGE PRE-TREATMENT, FINISHED WITH BAKED-ON POLYESTER POWDER COAT. FINISH SHALL PASS 2500 HOUR SALT SPRAY TEST PER ASTM B117. DARK BRONZE FINISH COLOR IS STANDARD.
3. REFLECTOR – ONE-PIECE, HYDROFORMED OR SEGMENTED, ANODIZED, SPECULAR ALUMINUM; PROVIDE IN IES/NEMA BEAM SPREAD PATTERN AS INDICATED.
4. LENS AND FRAME – DIE CAST, ANODIZED ALUMINUM FRAME WITH ONE-PIECE MOLDED, HIGH TEMPERATURE SILICONE OR NEOPRENE GASKET. LENS SHALL BE TEMPERED, BOROSILICATE GLASS. FRAME SHALL BE HINGED AT ONE END AND BE PROVIDED WITH LATCHES FOR SECURING WITHOUT THE NEED FOR TOOLS.
5. LIGHT SOURCE – METAL HALIDE IN WATTAGE AND TYPE AS INDICATED.
6. BALLAST – PREWIRED TO SEPARATE MOUNTING ASSEMBLY WITH QUICK DISCONNECT PLUGS. BALLAST SHALL BE HIGH POWER FACTOR (≥ 0.9), ENCASED AND POTTED (ENCAPSULATED), CONSTANT-WATTAGE AUTOTRANSFORMER, CORE AND COIL TYPE WITH MINIMUM STARTING TEMPERATURE OF MINUS 30 DEGREES C. PROVIDED PULSE START TYPE AS INDICATED AND WHEN AVAILABLE.
7. CERTIFICATION – UL AND/OR ETL LISTED FOR WET LOCATIONS.
8. OPTIONS – VARIOUS EXTERNAL SHIELDS AND INTERNAL CONCENTRIC LOUVERS, PHOTOCELL AND RECEPTACLE, AND FUSING.
9. OTHER – THE ABOVE SKETCH IS A NON-PROPRIETARY GRAPHIC REPRESENTATION OF A LUMINAIRE THAT MAY MEET THE SPECIFICATION REQUIREMENTS AND IS NOT INTENDED TO INDICATE A CERTAIN MANUFACTURER'S PREFERENCE. ALL DIMENSIONS ARE NOMINAL AND VARY PER MANUFACTURER.

HID SPORTS FIELD LUMINAIRE

REVISED:

MARCH 2013

LUMINAIRE PLATE:

XL-09

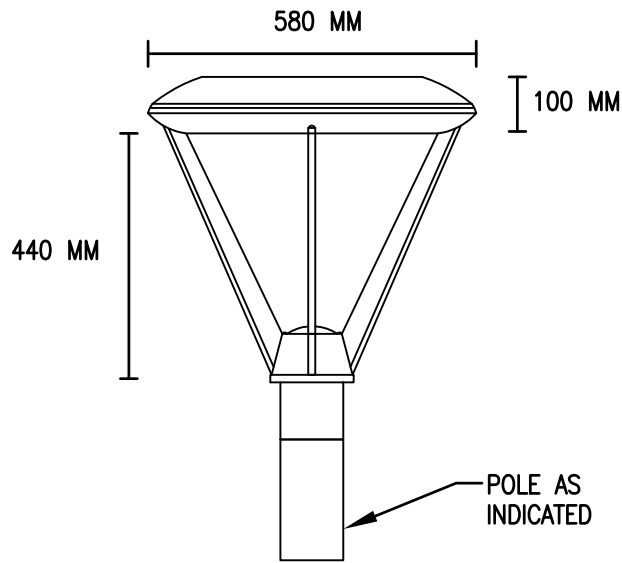

LUMINAIRE REQUIREMENTS:

1. HOUSING – DIE-CAST (MAIN HOUSING), EXTRUDED (ARMS), AND SPUN ALUMINUM (TOP). INTERNALLY WELD AND SEAL ALL CORNERS AND SEAMS OF HOUSING TO RESIST MOISTURE, AND DUST.
2. FINISH – MULTI-STAGE PRE-TREATMENT, FINISHED WITH BAKED-ON POLYESTER POWDER COAT. FINISH SHALL PASS 2500 HOUR SALT SPRAY TEST PER ASTM B117.
3. POWER SUPPLY/LED DRIVER – CLASS 1 DRIVER SHALL OPERATE AT 120/277V, 50/60 HZ WITH OTHER VOLTAGES OPTIONAL. POWER FACTOR GREATER THAN 0.9 AND THD LESS THAN 20% AT FULL LOAD. MINIMUM EFFICACY SHALL BE 65 LM/W AT MAXIMUM 600 mA OPERATING CURRENT.
4. LED OPTICAL ASSEMBLY– NUMBER OF LED ARRAYS SHALL VARY TO ACCOMMODATE DESIRED LUMINAIRE OUTPUT. PROVIDE IN NEMA TYPE TYPE I, II, III, IV OR V DISTRIBUTION AS INDICATED. MINIMUM COLOR RENDERING INDEX (CRI) SHALL BE 70 FOR CORRELATED COLOR TEMPERATURES (CCT) OF 4000-4500 DEGREES K.
5. SURGE PROTECTION – 6 kV MINIMUM, COMPLIANT WITH ANSI C62.41.2.
6. CERTIFICATION – UL AND/OR ETL LISTED, MINIMUM IP65 RATED PER ANSI/IEC 60529, AND RoHS COMPLIANT.
7. OPTIONS – FINISH COLOR, PHOTOCCELL AND RECEPTACLE, SHORTING CAP, BIRD SPIKES AND 0-10 VOLT DIMMING DRIVER.
8. OTHER – THE ABOVE SKETCH IS A NON-PROPRIETARY GRAPHIC REPRESENTATION OF A LUMINAIRE THAT MAY MEET THE SPECIFICATION REQUIREMENTS AND IS NOT INTENDED TO INDICATE A CERTAIN MANUFACTURER'S PREFERENCE. ALL DIMENSIONS ARE NOMINAL AND VARY PER MANUFACTURER.

LED PEDESTRIAN POST TOP LUMINAIRE

REVISED:

MARCH 2013

LUMINAIRE PLATE:

XL-10

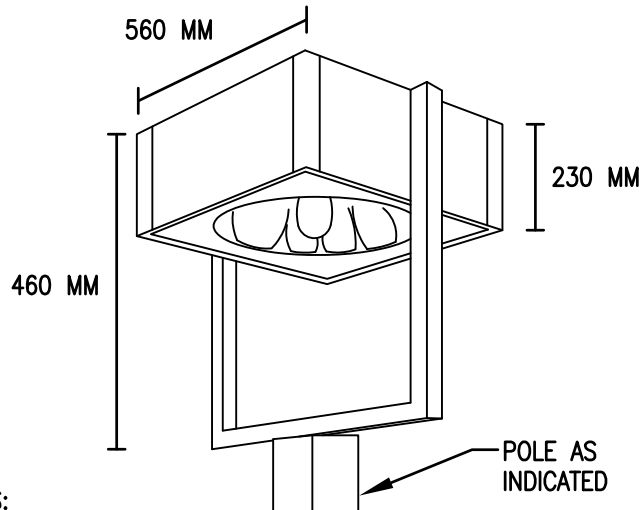

LUMINAIRE REQUIREMENTS:

1. HOUSING – DIE-CAST ALUMINUM (MAIN HOUSING) AND EXTRUDED ALUMINUM (ARMS OR YOKE). INTERNALLY SEAL ALL CORNERS AND SEAMS OF HOUSING TO RESIST MOISTURE, AND DUST.
2. FINISH – MULTI-STAGE PRE-TREATMENT, FINISHED WITH BAKED-ON POLYESTER POWDER COAT. FINISH SHALL PASS 2500 HOUR SALT SPRAY TEST PER ASTM B117.
3. REFLECTOR – ONE-PIECE, MULTI-FACETED, ANODIZED, SPECULAR ALUMINUM, PRODUCING NEMA DISTRIBUTION PATTERN III, IV OR V AS INDICATED. BUG UPLIGHT RATING SHALL BE U0, WITH BACKLIGHT AND GLARE RATINGS AS DETERMINED BY LIGHTING ZONE INSTALLED.
4. BALLAST/GENERATOR – TYPE A – CLASS P, HIGH POWER FACTOR, PROGRAMMED START, ELECTRONIC TYPE FOR COMPACT FLUORESCENT LIGHT SOURCE.
TYPE B – ENCAPSULATED, CWA, HIGH POWER FACTOR, CORE AND COIL OR ELECTRONIC FOR METAL HALIDE LIGHT SOURCE (PROVIDE PULSE START WHEN AVAILABLE).
TYPE C – SOLID STATE, HIGH POWER FACTOR (≥ 0.9) HIGH FREQUENCY GENERATOR FOR INDUCTION LIGHT SOURCE.
5. LENS AND FRAME – DIE-CAST ALUMINUM FRAME WITH SILICONE GASKET. LENS SHALL BE TEMPERED GLASS WITH POLYCARBONATE, VANDAL-RESISTANT OPTION.
6. LIGHT SOURCE – TYPE A – METAL HALIDE
TYPE B – COMPACT FLUORESCENT
TYPE C – INDUCTION VESSEL
7. CERTIFICATION – UL AND/OR ETL LISTED FOR WET LOCATIONS AND RoHS COMPLIANT.
8. OPTIONS – FINISH COLOR, PHOTOCCELL AND RECEPTACLE, HOUSE-SIDE SHIELD, AND FUSING.
9. OTHER – THE ABOVE SKETCH IS A NON-PROPRIETARY GRAPHIC REPRESENTATION OF A LUMINAIRE THAT MAY MEET THE SPECIFICATION REQUIREMENTS AND IS NOT INTENDED TO INDICATE A CERTAIN MANUFACTURER'S PREFERENCE. ALL DIMENSIONS ARE NOMINAL AND VARY PER MANUFACTURER.

HID/CFL/INDUCTION PEDESTRIAN POST TOP LUMINAIRE

REVISED:

MARCH 2013

LUMINAIRE PLATE:

XL-11

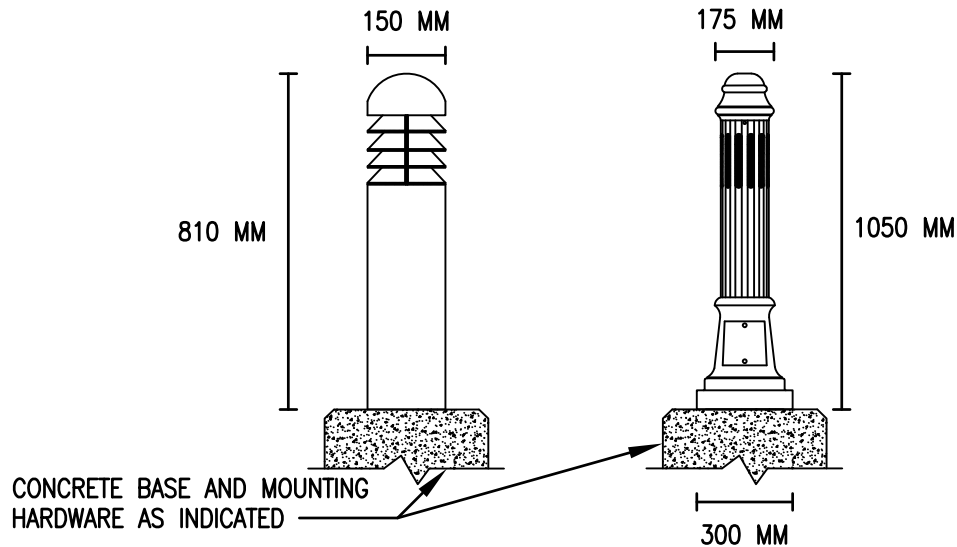

LUMINAIRE REQUIREMENTS:

1. HOUSING – EXTRUDED OR HEAVY-DUTY DIE-CAST ALUMINUM; CONCRETE OPTIONAL. ALL EXPOSED HARDWARE SHALL BE STAINLESS STEEL.
2. FINISH – MULTI-STAGE PRE-TREATMENT, FINISHED WITH BAKED-ON POLYESTER POWDER COAT. FINISH SHALL PASS 2500 HOUR SALT SPRAY TEST PER ASTM B117. CONCRETE MODEL SHALL HAVE OPTIONAL IMPREGNATED COLOR AND SMOOTH OR AGGREGATE FINISH AS INDICATED.
3. BALLAST/DRIVER –
TYPE A – CLASS P, HIGH POWER FACTOR, PROGRAMMED START, ELECTRONIC TYPE FOR COMPACT FLUORESCENT LIGHT SOURCE.
TYPE B – ENCAPSULATED, CWA, HIGH POWER FACTOR, COIL AND CORE OR ELECTRONIC FOR METAL HALIDE LIGHT SOURCE (PROVIDE PULSE START WHEN AVAILABLE).
TYPE C – CLASS 1, CONSTANT CURRENT, ELECTRONIC DRIVER FOR LED LIGHT SOURCE
4. OPTICAL ASSEMBLY –
TYPES A AND B – ANODIZED, SPECULAR ALUMINUM WITH ACRYLIC OR TEMPERED GLASS LENS FOR METAL HALIDE AND CFL.
TYPE C – DIRECTIONAL LED ASSEMBLIES FOR MAXIMUM BEAM ANGLE PROJECTION THROUGH LOUVERS OR OPENINGS IN LUMINAIRE BODY. PROVIDE NEMA TYPE I, III OR V DISTRIBUTION AS INDICATED.
5. LIGHT SOURCE – COMPACT FLUORESCENT, METAL HALIDE OR LED.
6. CERTIFICATION – UL AND/OR ETL LISTED FOR WET LOCATION AND RoHS COMPLIANT.
7. OPTIONS – CLEAR OR FROSTED LENS, HOUSE SIDE SHIELD FOR 90 OR 180 DEGREE COVERAGE.
8. OTHER – THE ABOVE SKETCH IS A NON-PROPRIETARY GRAPHIC REPRESENTATION OF A LUMINAIRE THAT MAY MEET THE SPECIFICATION REQUIREMENTS AND IS NOT INTENDED TO INDICATE A CERTAIN MANUFACTURER’S PREFERENCE. ALL DIMENSIONS ARE NOMINAL AND VARY PER MANUFACTURER.

DECORATIVE BOLLARD

REVISED:

MARCH 2013

LUMINAIRE PLATE:

XL-12

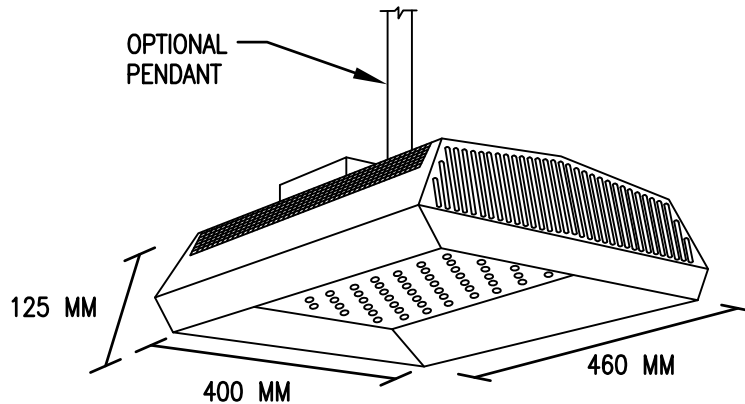

LUMINAIRE REQUIREMENTS:

1. HOUSING – DIE-CAST ALUMINUM WITH INTEGRAL, SELF-CLEANING HEAT SINK FINS, RIBS, OR EQUIVALENT PASSIVE COOLING MECHANISM. HEAT SINK SHALL BE INCORPORATED DIRECTLY INTO HOUSING TO ENSURE MAXIMUM HEAT TRANSFER AND DISSIPATION.
2. FINISH – MULTI-STAGE PRE-TREATMENT, FINISHED IN NATURAL ALUMINUM BAKED-ON POLYESTER POWDER COAT. FINISH SHALL PASS 2500 HOUR SALT SPRAY TEST PER ASTM B117. OTHER FINISH COLORS INCLUDE DARK BRONZE, SILVER, OR BLACK WITH CUSTOM COLORS AVAILABLE.
3. POWER SUPPLY/LED DRIVER – CLASS 1 DRIVER SHALL OPERATE AT 120/277V, 50/60 HZ; OTHER VOLTAGES OPTIONAL. POWER FACTOR GREATER THAN 0.9 AND THD LESS THAN 20% AT FULL LOAD. MINIMUM EFFICACY SHALL BE 70 LM/W AT MAXIMUM 600 mA OPERATING CURRENT.
4. LED OPTICAL ASSEMBLY – NUMBER OF LED ARRAYS SHALL VARY TO ACCOMMODATE DESIRED LUMINAIRE OUTPUT. PROVIDE WITH EQUIVALENT NEMA TYPE V DISTRIBUTION OR AS OTHERWISE INDICATED. BUG UPLIGHT RATING OF U0, WITH BACKLIGHT AND GLARE RATINGS AS DETERMINED BY LIGHTING ZONE INSTALLED. MINIMUM COLOR RENDERING INDEX (CRI) SHALL BE 70 FOR CORRELATED COLOR TEMPERATURE (CCT) OF 4000–4500 DEGREES K.
5. SURGE PROTECTION – 6 kV MINIMUM, COMPLIANT WITH ANSI C62.41.2.
6. CERTIFICATION – UL AND/OR ETL LISTED, MINIMUM IP65 RATED PER ANSI/IEC 60529, AND RoHS COMPLIANT.
7. OPTIONS – MOTION SENSOR, PHOTOCCELL, BIRD SPIKES, AND 0–10 VOLT DIMMING DRIVER.
8. OTHER – THE ABOVE SKETCH IS A NON-PROPRIETY GRAPHIC REPRESENTATION OF A LUMINAIRE THAT MAY MEET THE SPECIFICATION REQUIREMENTS AND IS NOT INTENDED TO INDICATE A CERTAIN MANUFACTURER’S PREFERENCE. ALL DIMENSIONS ARE NOMINAL AND VARY PER MANUFACTURER.

LED PARKING GARAGE LUMINAIRE

REVISED:

MARCH 2013

LUMINAIRE PLATE:

XL-13

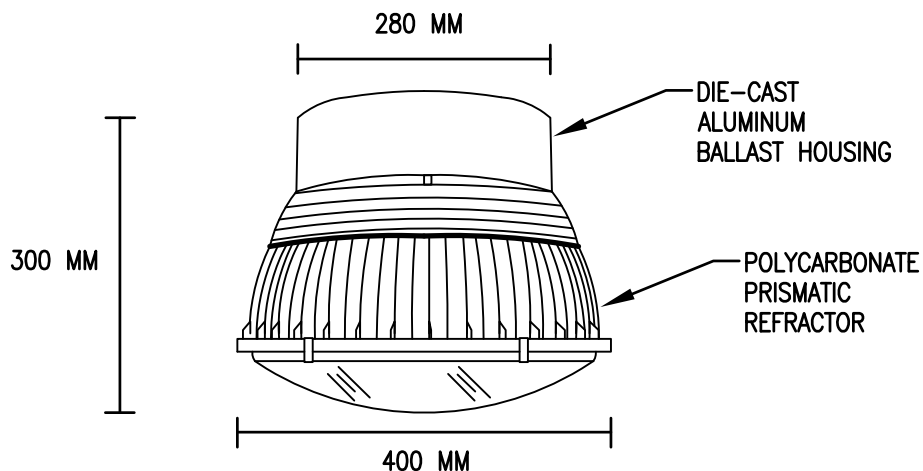

LUMINAIRE REQUIREMENTS:

1. HOUSING – DIE-CAST ALUMINUM BALLAST HOUSING WITH POLYCARBONATE, PRISMATIC REFRACTOR. ALL HARDWARE SHALL BE STAINLESS STEEL.
2. FINISH – MULTI-STAGE PRE-TREATMENT, FINISHED WITH BAKED-ON POLYESTER POWDER COAT. FINISH SHALL PASS 2500 HOUR SALT SPRAY TEST PER ASTM B117.
3. REFLECTOR – TWO-PIECE, MULTI-FACETED, ANODIZED, SPECULAR ALUMINUM, PRODUCING DISTRIBUTION PATTERN AS INDICATED.
4. BALLAST/GENERATOR – TYPE A – ENCAPSULATED, CWA, HIGH POWER FACTOR, CORE AND COIL OR ELECTRONIC FOR METAL HALIDE LIGHT SOURCE (PROVIDE PULSE START WHEN AVAILABLE).
TYPE B – SOLID STATE, HIGH POWER FACTOR (≥ 0.9) HIGH FREQUENCY GENERATOR FOR INDUCTION LIGHT SOURCE.
5. LENS AND FRAME – STAINLESS STEEL OR ALUMINUM LENS RING WITH SILICONE GASKET. LENS SHALL BE TEMPERED GLASS WITH POLYCARBONATE, VANDAL-RESISTANT OPTION.
6. LIGHT SOURCE – TYPE A – METAL HALIDE
TYPE C – INDUCTION VESSEL
7. CERTIFICATION – UL AND/OR ETL LISTED FOR WET LOCATIONS AND RoHS COMPLIANT.
8. OPTIONS – PENDENT MOUNTING, FINISH COLOR, MOTION DETECTOR, AND FUSING.
9. OTHER – THE ABOVE SKETCH IS A NON-PROPRIETARY GRAPHIC REPRESENTATION OF A LUMINAIRE THAT MAY MEET THE SPECIFICATION REQUIREMENTS AND IS NOT INTENDED TO INDICATE A CERTAIN MANUFACTURER'S PREFERENCE. ALL DIMENSIONS ARE NOMINAL AND VARY PER MANUFACTURER.

HID/INDUCTION PARKING GARAGE LUMINAIRE

REVISED:

MARCH 2013

LUMINAIRE PLATE:

XL-14

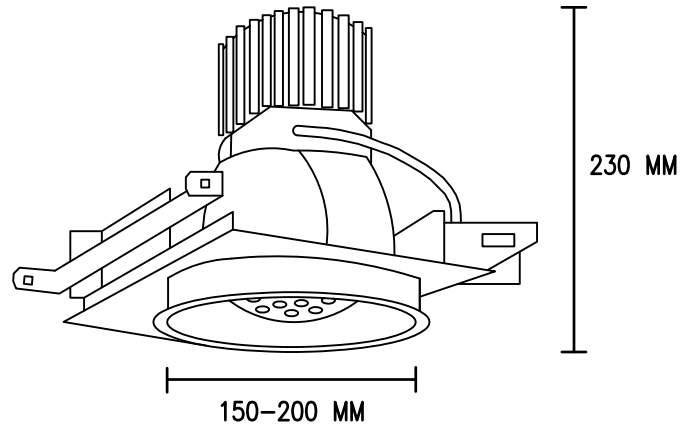

LUMINAIRE REQUIREMENTS:

1. HOUSING – ONE-PIECE, NON-CORROSIVE STEEL WITH ALUMINUM HEAT SINK. HEAT SINK SHALL BE INCORPORATED DIRECTLY INTO DRIVER COMPARTMENT TO ENSURE MAXIMUM HEAT TRANSFER AND DISSIPATION.
2. REFLECTOR – ONE-PIECE, IRIDESCENCE-SUPPRESSED ALUMINUM. PAINTED WHITE SELF-TRIM AND OTHER REFLECTOR FINISHES AS INDICATED.
3. BALLAST/LED DRIVER – TYPE A – CLASS P, HIGH POWER FACTOR, PROGRAMMED START, ELECTRONIC TYPE FOR COMPACT FLUORESCENT LIGHT SOURCE.
TYPE B – CLASS 1, CONSTANT CURRENT, ELECTRONIC DRIVER WITH 0-10 VOLT DIMMING FOR LED LIGHT SOURCE.
4. LIGHT SOURCE – TYPE A – MULTI-TUBE, PROGRAMMED START, LOW-MERCURY, 4-PIN CFL WITH WATTAGE AND CCT AS INDICATED.
TYPE B – MULTI-LED ARRAY WITH MINIMUM CRI OF 70 AT A CCT OF 4000-4500 DEGREES K. LUMEN OUTPUT AND WATTAGE AS INDICATED.
5. CERTIFICATION – UL AND/OR ETL LISTED FOR DAMP OR WET LOCATIONS AS INDICATED, AND RoHS COMPLIANT.
6. OPTIONS – EMERGENCY BATTERY INVERTER. REFLECTOR COLOR AND FINISH, AND APERTURE OPENING SIZE OF 150 MM OR 200 MM.
7. OTHER – THE ABOVE SKETCH IS A NON-PROPRIETY GRAPHIC REPRESENTATION OF A LUMINAIRE THAT MAY MEET THE SPECIFICATION REQUIREMENTS AND IS NOT INTENDED TO INDICATE A CERTAIN MANUFACTURER'S PREFERENCE. ALL DIMENSIONS ARE NOMINAL AND VARY PER MANUFACTURER.

EXTERIOR RECESSED DOWNLIGHT

REVISED:

MARCH 2013

LUMINAIRE PLATE:

XL-15

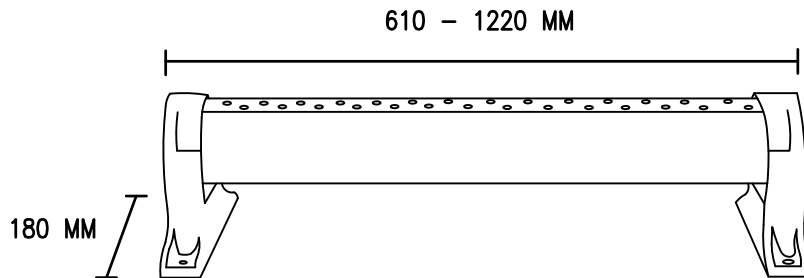

LUMINAIRE REQUIREMENTS:

1. HOUSING – EXTRUDED ALUMINUM WITH DIE-CAST END CAPS AND INTEGRAL PASSIVE COOLING MECHANISM. HEAT SINK SHALL BE INCORPORATED DIRECTLY INTO HOUSING OR DRIVER COMPARTMENT TO ENSURE MAXIMUM HEAT TRANSFER AND DISSIPATION.
2. FINISH – MULTI-STAGE PRE-TREATMENT, FINISHED WITH BAKED-ON POLYESTER POWDER COAT. FINISH SHALL PASS 2500 HOUR SALT SPRAY TEST PER ASTM B117. STANDARD FINISH IS SILVER, WITH OTHER CUSTOM COLORS AVAILABLE.
3. POWER SUPPLY/LED DRIVER – CLASS 1 DRIVER SHALL OPERATE AT 120/277 VOLTS, 50/60 HZ, WITH OTHER VOLTAGES OPTIONAL; POWER FACTOR GREATER THAN 0.9 AND THD LESS THAN 20% AT FULL LOAD. MINIMUM EFFICACY SHALL BE 60 LM/W AT MAXIMUM 600mA OPERATING CURRENT.
4. LED OPTICAL ASSEMBLY – PRECISION MOLDED ACRYLIC "LIGHT BAR" INCORPORATES MULTIPLE HIGH-POWERED LEDS. BUG UPLIGHT RATING OF U0 WHEN ROTATABLE LIGHT BAR TURNED TO DOWN POSITION. MINIMUM COLOR RENDERING INDEX (CRI) SHALL BE 70 FOR CORRELATED COLOR TEMPERATURE (CCT) OF 4000-4500 DEGREES K.
5. CERTIFICATION – UL AND/OR ETL LISTED FOR WET LOCATIONS, MINIMUM IP65 RATED PER ANSI/IEC 60529, AND RoHS COMPLIANT.
6. OPTIONS – VARIOUS LUMEN OUTPUT RATING AND LENGTH AS INDICATED, PHOTOCELL, AND 0-10 VOLT DIMMING DRIVER.
7. OTHER – THE ABOVE SKETCH IS A NON-PROPRIETY GRAPHIC REPRESENTATION OF A LUMINAIRE THAT MAY MEET THE SPECIFICATION REQUIREMENTS AND IS NOT INTENDED TO INDICATE A CERTAIN MANUFACTURER'S PREFERENCE. ALL DIMENSIONS ARE NOMINAL AND VARY PER MANUFACTURER.

LED LINEAR WALL WASH

REVISED:

MARCH 2013

LUMINAIRE PLATE:

XL-16

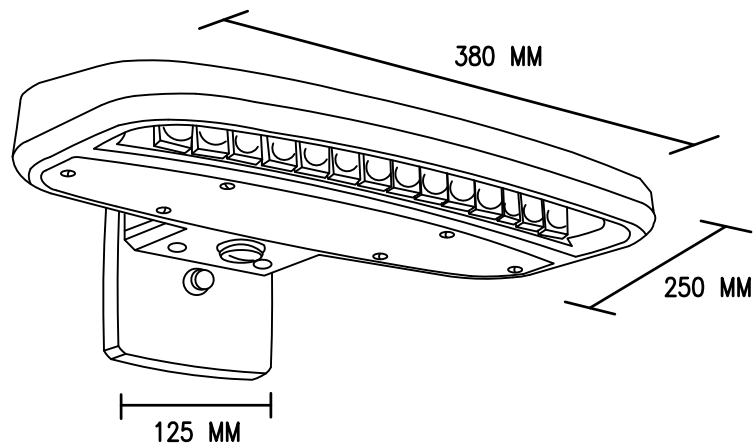

LUMINAIRE REQUIREMENTS:

1. HOUSING – DIE-CAST OR EXTRUDED ALUMINUM WITH INTEGRAL PASSIVE COOLING MECHANISM. HEAT SINK SHALL BE INCORPORATED DIRECTLY INTO HOUSING OR DRIVER COMPARTMENT TO ENSURE MAXIMUM HEAT TRANSFER AND DISSIPATION.
2. FINISH – MULTI-STAGE PRE-TREATMENT, FINISHED WITH BAKED-ON POLYESTER POWDER COAT. FINISH SHALL PASS 2500 HOUR SALT SPRAY TEST PER ASTM B117. STANDARD FINISH IS DARK BRONZE, WITH OTHER CUSTOM COLORS AVAILABLE.
3. POWER SUPPLY/LED DRIVER – CLASS 1 DRIVER SHALL OPERATE AT 120/277 VOLTS, 50/60 HZ, WITH OTHER VOLTAGES OPTIONAL; POWER FACTOR GREATER THAN 0.9 AND THD LESS THAN 20% AT FULL LOAD. MINIMUM EFFICACY SHALL BE 60 LM/W AT MAXIMUM 600mA OPERATING CURRENT.
4. LED OPTICAL ASSEMBLY – PRECISION MOLDED ACRYLIC LENS PROVIDED FOR MULTIPLE HIGH-POWERED LEDS PRODUCING NEMA TYPE III DISTRIBUTION OR AS OTHERWISE INDICATED. BUG UPLIGHT RATING OF U0, WITH GLARE RATING AS DETERMINED BY LIGHTING ZONE INSTALLED. MINIMUM COLOR RENDERING INDEX (CRI) SHALL BE 70 FOR CORRELATED COLOR TEMPERATURE (CCT) OF 4000-4500 DEGREES K.
5. CERTIFICATION – UL AND/OR ETL LISTED FOR DAMP OR WET LOCATIONS AS INDICATED, AND RoHS COMPLIANT.
6. OPTIONS – VARIOUS LUMEN OUTPUT RATING AS INDICATED, PHOTOCCELL, AND 0-10 VOLT DIMMING DRIVER.
7. OTHER – THE ABOVE SKETCH IS A NON-PROPRIETY GRAPHIC REPRESENTATION OF A LUMINAIRE THAT MAY MEET THE SPECIFICATION REQUIREMENTS AND IS NOT INTENDED TO INDICATE A CERTAIN MANUFACTURER'S PREFERENCE. ALL DIMENSIONS ARE NOMINAL AND VARY PER MANUFACTURER.

LED WALL PACK

REVISED:

MARCH 2013

LUMINAIRE PLATE:

XL-17

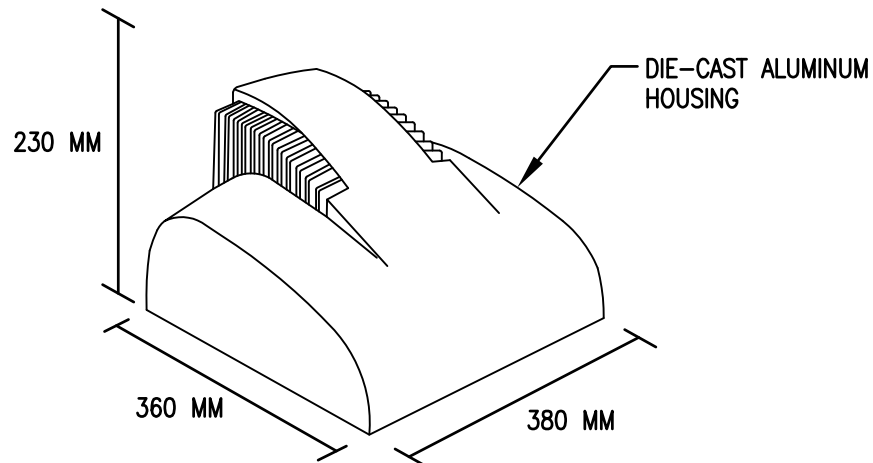

LUMINAIRE REQUIREMENTS:

1. HOUSING – ONE-PIECE, DIE-CAST ALUMINUM. ALL EXPOSED HARDWARE SHALL BE STAINLESS STEEL.
2. FINISH – MULTI-STAGE PRE-TREATMENT, FINISHED WITH BAKED-ON POLYESTER POWDER COAT. FINISH SHALL PASS 2500 HOUR SALT SPRAY TEST PER ASTM B117. FINISH COLORS INCLUDE DARK BRONZE, GREY OR BLACK WITH CUSTOM COLORS AVAILABLE.
3. REFLECTOR – ONE-PIECE, HYDROFORMED OR SEGMENTED, ANODIZED, SPECULAR OR SEMI-SPECULAR ALUMINUM. PROVIDE WITH NEMA DISTRIBUTION PATTERN AS INDICATED. BUG UPLIGHT RATING SHALL BE U0, WITH BACKLIGHT AND GLARE RATINGS AS DETERMINED BY LIGHTING ZONE INSTALLED.
4. LENS AND FRAME – DIE-CAST ALUMINUM FRAME WITH ONE-PIECE, MOLDED SILICON GASKET. LENS SHALL BE TEMPERED GLASS WITH POLYCARBONATE, VANDAL-RESISTANT OPTION.
5. BALLAST/GENERATOR – TYPE A – ENCAPSULATED, CWA, HIGH POWER FACTOR, CORE AND COIL OR ELECTRONIC FOR METAL HALIDE LIGHT SOURCE; (PROVIDE PULSE START WHEN AVAILABLE).
TYPE B – SOLID STATE, HIGH POWER FACTOR (≥ 0.9), HIGH FREQUENCY GENERATOR FOR INDUCTION LIGHT SOURCE.
6. LIGHT SOURCE – TYPE A – METAL HALIDE
TYPE B – INDUCTION VESSEL
7. CERTIFICATION – UL AND/OR ETL LISTED FOR WET LOCATIONS AND RoHS COMPLIANT.
8. OPTIONS – FINISH COLOR, PHOTOCCELL, POLYCARBONATE LENS.
9. OTHER – THE ABOVE SKETCH IS A NON-PROPRIETARY GRAPHIC REPRESENTATION OF A LUMINAIRE THAT MAY MEET THE SPECIFICATION REQUIREMENTS AND IS NOT INTENDED TO INDICATE A CERTAIN MANUFACTURER'S PREFERENCE. ALL DIMENSIONS ARE NOMINAL AND VARY PER MANUFACTURER.

HID/INDUCTION WALL PACK

REVISED:

MARCH 2013

LUMINAIRE PLATE:

XL-18

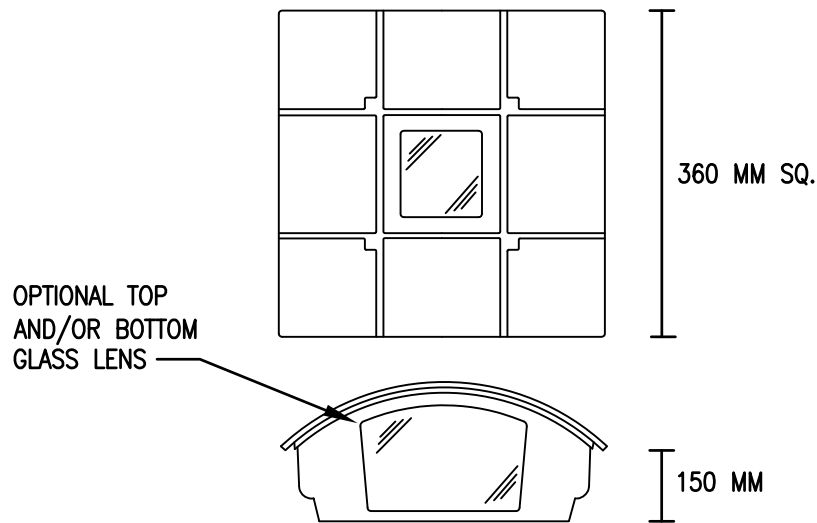

LUMINAIRE REQUIREMENTS:

1. HOUSING – ONE-PIECE, DIE-CAST ALUMINUM FACEPLATE AND HOUSING. ALL HARDWARE SHALL BE STAINLESS STEEL. HEAT SINK FOR LED TYPE SHALL BE INCORPORATED DIRECTLY INTO HOUSING OR DRIVER COMPARTMENT TO ENSURE MAXIMUM HEAT TRANSFER AND DISSIPATION.
2. FINISH – MULTI-STAGE PRE-TREATMENT, FINISHED WITH BAKED-ON POLYESTER POWDER COAT. FINISH SHALL PASS 2500 HOUR SALT SPRAY TEST PER ASTM B117.
3. BALLAST/DRIVER – TYPE A – CLASS P, HIGH POWER FACTOR, PROGRAMMED START, ELECTRONIC TYPE FOR COMPACT FLUORESCENT LIGHT SOURCE.
TYPE B – CLASS 1, CONSTANT CURRENT, ELECTRONIC DRIVER FOR LED LIGHT SOURCE.
4. LENS – TEMPERED GLASS FRONT LENS WITH OPTIONAL TOP AND/OR BOTTOM LENS AVAILABLE.
5. OPTICAL ASSEMBLY – REFLECTOR SHALL BE MULTI-FACETED, SEMI-SPECULAR ALUMINUM.
6. LIGHT SOURCE – TYPE A – MULTI-TUBE, PROGRAMMED START, LOW-MERCURY, 4-PIN CFL WITH WATTAGE AND CCT AS INDICATED.
TYPE B – MULTI-LED ARRAY WITH MINIMUM CRI OF 70 AT A CCT OF 4000-4500 DEGREES K. LUMEN OUTPUT AND WATTAGE AS INDICATED.
7. CERTIFICATION – UL AND/OR ETL LISTED FOR DAMP OR WET LOCATIONS AS INDICATED, AND RoHS COMPLIANT.
8. OPTIONS – PHOTOCELL, 0-10 VOLT DIMMING DRIVER, AND BATTERY BACK-UP.
9. OTHER – THE ABOVE SKETCH IS A NON-PROPRIETARY GRAPHIC REPRESENTATION OF A LUMINAIRE THAT MAY MEET THE SPECIFICATION REQUIREMENTS AND IS NOT INTENDED TO INDICATE A CERTAIN MANUFACTURER'S PREFERENCE. ALL DIMENSIONS ARE NOMINAL AND VARY PER MANUFACTURER.

DECORATIVE WALL SCONCE

REVISED:

MARCH 2013

LUMINAIRE PLATE:

XL-19

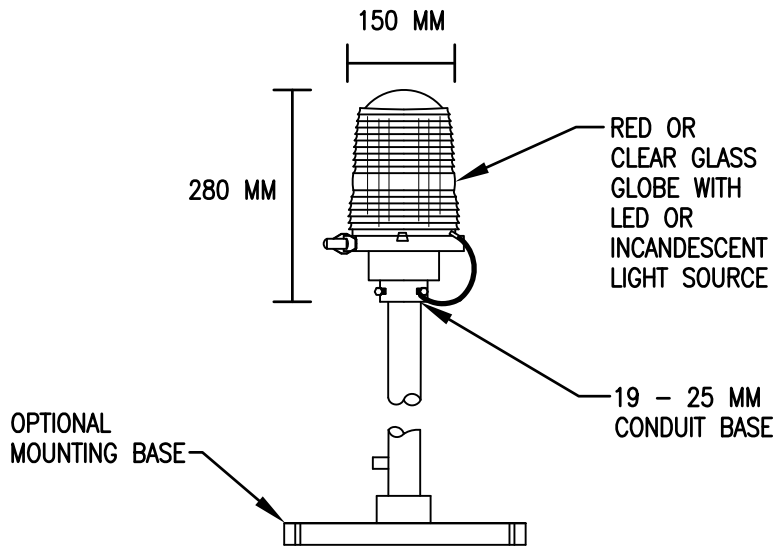

LUMINAIRE REQUIREMENTS:

1. HOUSING – DIE-CAST ALUMINUM WITH POLYESTER POWDER COAT FINISH. HARDWARE SHALL BE STAINLESS STEEL. NEMA 4X AND IP66 RATED FOR INGRESS PROTECTION.
2. MOUNTING – 19 MM OR 25 MM THREADED BOTTOM CONDUIT ENTRY.
3. GLOBE – TEMPERED RED OR CLEAR FRESNEL GLASS WITH STAINLESS STEEL LATCHING SYSTEM TO HOLD GLOBE FIRMLY ONTO BASE. PROVIDE CABLE TETHER WIRE. WAVELENGTH OF GLASS SHALL BE MATCHED TO PROVIDE MAXIMUM OUTPUT FROM LED LIGHT SOURCE (WHEN UTILIZED).
4. LIGHT SOURCE – RED, HIGH POWER, CONSTANT-CURRENT DRIVEN LEDS, OR LONG LIFE, 116 W, MEDIUM SCREW BASE INCANDESCENT. LEDS ARE NOT APPROVED FOR USE IN AIR FORCE PROJECTS.
5. CERTIFICATION – FAA L810 PER FAA ADVISORY CIRCULAR 150/5345-43F.
6. OPTIONS – PROVIDE SINGLE OR TWIN GLOBE AS INDICATED IN LUMINAIRE SCHEDULE.
7. OTHER – THE ABOVE SKETCH IS A NON-PROPRIETARY GRAPHIC REPRESENTATION OF A LUMINAIRE THAT MAY MEET THE SPECIFICATION REQUIREMENTS AND IS NOT INTENDED TO INDICATE A CERTAIN MANUFACTURER’S PREFERENCE. ALL DIMENSIONS ARE NOMINAL AND VARY PER MANUFACTURER.

AVIATION OBSTRUCTION LUMINAIRE

REVISED:

MARCH 2013

LUMINAIRE PLATE:

XL-20

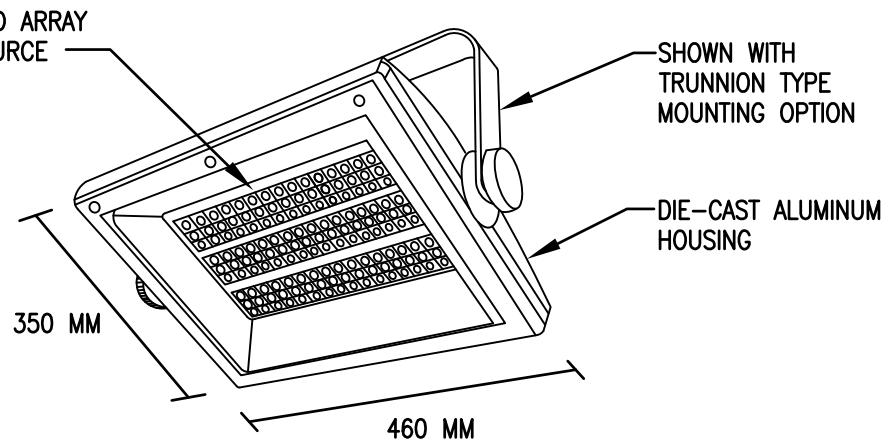

LUMINAIRE REQUIREMENTS:

1. HOUSING – DIE CAST ALUMINUM WITH INTEGRAL PASSIVE COOLING MECHANISM. HEAT SINK SHALL BE INCORPORATED DIRECTLY INTO HOUSING TO ENSURE MAXIMUM HEAT TRANSFER AND DISSIPATION.
2. FINISH – MULTI-STAGE PRE-TREATMENT, FINISHED WITH BAKED-ON POLYESTER POWDER COAT. FINISH SHALL PASS 2500 HOUR SALT SPRAY TEST PER ASTM B117. DARK BRONZE FINISH COLOR IS STANDARD.
3. POWER SUPPLY/LED DRIVER – CLASS 1 ELECTRONIC DRIVER SHALL OPERATE AT 120/277 VOLTS, 50/60 HZ, WITH OTHER VOLTAGES OPTIONAL. POWER FACTOR SHALL BE GREATER THAN 0.9 AND THD LESS THAN 20% AT FULL LOAD. MINIMUM EFFICACY SHALL BE 60 LM/W AT MAXIMUM 600mA OPERATING CURRENT.
4. LED OPTICAL ASSEMBLY – MULTI-LED ARRAY OPTIMIZED FOR SPECIFIC DISTRIBUTION PATTERN AS INDICATED. MINIMUM COLOR RENDERING INDEX (CRI) OF 70 FOR CORRELATED COLOR TEMPERATURE OF 4000-4500 DEGREES K.
5. LENS – TEMPERED GLASS IN DIE-CAST ALUMINUM FRAME WITH SILICONE GASKET.
6. SURGE PROTECTION – 6 KV MINIMUM, COMPLIANT WITH ANSI C62.41.2.
7. CERTIFICATION – UL AND/OR ETL LISTED FOR WET LOCATIONS AND 2G VIBRATION STANDARD PER ANSI C136.32. OPTICAL ASSEMBLY SHALL BE MINIMUM IP65 PER ANSI/IEC 60529.
8. OPTIONS – PHOTOCCELL, FINISH COLOR, OUTPUT DISTRIBUTION TYPE AND TRUNNION OR SLIPFITTER TYPE MOUNTING.
9. OTHER – THE ABOVE SKETCH IS A NON-PROPRIETARY GRAPHIC REPRESENTATION OF A LUMINAIRE THAT MAY MEET THE SPECIFICATION REQUIREMENTS AND IS NOT INTENDED TO INDICATE A CERTAIN MANUFACTURER'S PREFERENCE. ALL DIMENSIONS ARE NOMINAL AND VARY PER MANUFACTURER.

LED FLOOD LUMINAIRE

REVISED:

MARCH 2013

LUMINAIRE PLATE:

XL-21

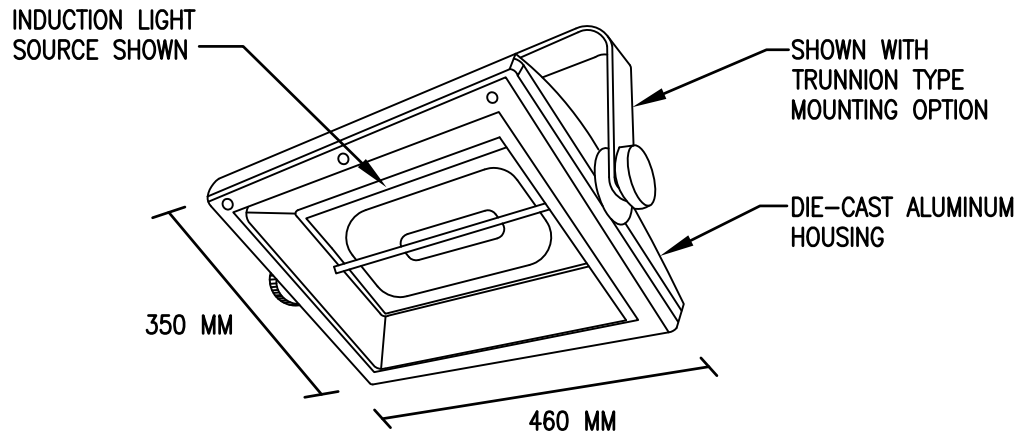

LUMINAIRE REQUIREMENTS:

1. HOUSING – ONE-PIECE, DIE-CAST ALUMINUM. ALL EXPOSED HARDWARE SHALL BE STAINLESS STEEL.
2. FINISH – MULTI-STAGE PRE-TREATMENT, FINISHED WITH BAKED-ON POLYESTER POWDER COAT. FINISH SHALL PASS 2500 HOUR SALT SPRAY TEST PER ASTM B117. FINISH COLORS INCLUDE DARK BRONZE, GREY OR BLACK WITH CUSTOM COLORS AVAILABLE.
3. REFLECTOR – ONE-PIECE, HYDROFORMED OR SEGMENTED, ANODIZED, SPECULAR OR SEMI-SPECULAR ALUMINUM. PROVIDE WITH NEMA DISTRIBUTION PATTERN AS INDICATED. BUG UPLIGHT RATING SHALL BE U0, WITH BACKLIGHT AND GLARE RATINGS AS DETERMINED BY LIGHTING ZONE INSTALLED.
4. LENS AND FRAME – DIE-CAST ALUMINUM FRAME WITH ONE-PIECE, MOLDED SILICON GASKET. LENS SHALL BE TEMPERED GLASS WITH POLYCARBONATE, VANDAL-RESISTANT OPTION.
5. BALLAST/GENERATOR – TYPE A – ENCAPSULATED, CWA, HIGH POWER FACTOR, CORE AND COIL OR ELECTRONIC FOR METAL HALIDE LIGHT SOURCE; (PROVIDE PULSE START WHEN AVAILABLE).
TYPE B – SOLID STATE, HIGH POWER FACTOR (≥ 0.9), HIGH FREQUENCY GENERATOR FOR INDUCTION LIGHT SOURCE.
6. LIGHT SOURCE – TYPE A – METAL HALIDE
TYPE B – INDUCTION VESSEL
7. CERTIFICATION – UL AND/OR ETL LISTED FOR WET LOCATIONS AND RoHS COMPLIANT.
8. OPTIONS – FINISH COLOR, PHOTOCELL, POLYCARBONATE LENS.
9. OTHER – THE ABOVE SKETCH IS A NON-PROPRIETARY GRAPHIC REPRESENTATION OF A LUMINAIRE THAT MAY MEET THE SPECIFICATION REQUIREMENTS AND IS NOT INTENDED TO INDICATE A CERTAIN MANUFACTURER'S PREFERENCE. ALL DIMENSIONS ARE NOMINAL AND VARY PER MANUFACTURER.

HID/INDUCTION FLOOD LUMINAIRE

REVISED:

MARCH 2013

LUMINAIRE PLATE:

XL-22

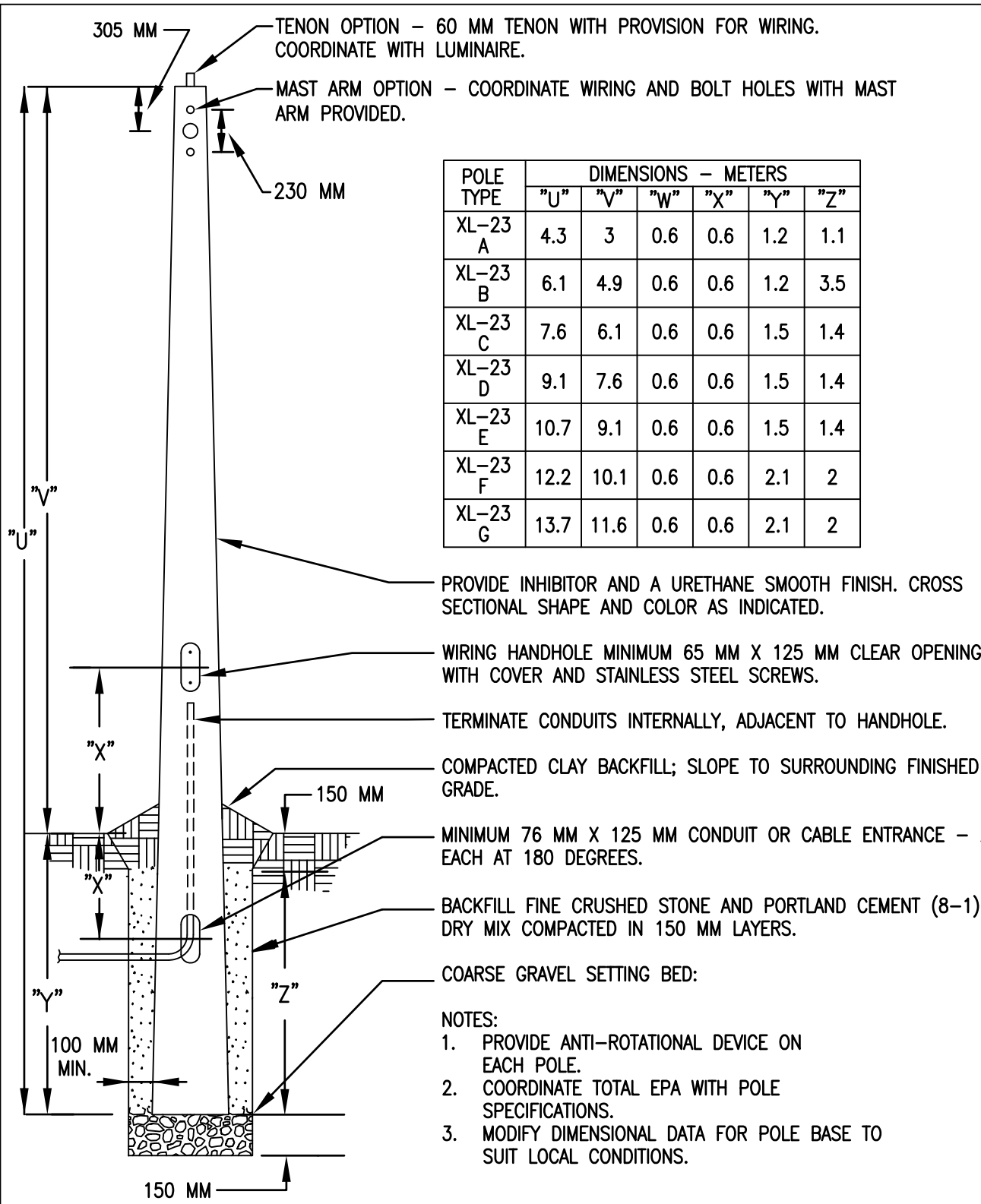

POLE TYPE	DIMENSIONS - METERS					
	"U"	"V"	"W"	"X"	"Y"	"Z"
XL-23 A	4.3	3	0.6	0.6	1.2	1.1
XL-23 B	6.1	4.9	0.6	0.6	1.2	3.5
XL-23 C	7.6	6.1	0.6	0.6	1.5	1.4
XL-23 D	9.1	7.6	0.6	0.6	1.5	1.4
XL-23 E	10.7	9.1	0.6	0.6	1.5	1.4
XL-23 F	12.2	10.1	0.6	0.6	2.1	2
XL-23 G	13.7	11.6	0.6	0.6	2.1	2

PROVIDE INHIBITOR AND A URETHANE SMOOTH FINISH. CROSS SECTIONAL SHAPE AND COLOR AS INDICATED.

WIRING HANDHOLE MINIMUM 65 MM X 125 MM CLEAR OPENING WITH COVER AND STAINLESS STEEL SCREWS.

TERMINATE CONDUITS INTERNALLY, ADJACENT TO HANDHOLE.

150 MM

COMPACTED CLAY BACKFILL; SLOPE TO SURROUNDING FINISHED GRADE.

MINIMUM 76 MM X 125 MM CONDUIT OR CABLE ENTRANCE - 2 EACH AT 180 DEGREES.

BACKFILL FINE CRUSHED STONE AND PORTLAND CEMENT (8-1) DRY MIX COMPACTED IN 150 MM LAYERS.

COARSE GRAVEL SETTING BED:

- NOTES:
1. PROVIDE ANTI-ROTATIONAL DEVICE ON EACH POLE.
 2. COORDINATE TOTAL EPA WITH POLE SPECIFICATIONS.
 3. MODIFY DIMENSIONAL DATA FOR POLE BASE TO SUIT LOCAL CONDITIONS.

DIRECT-SET FIBERGLASS POLE

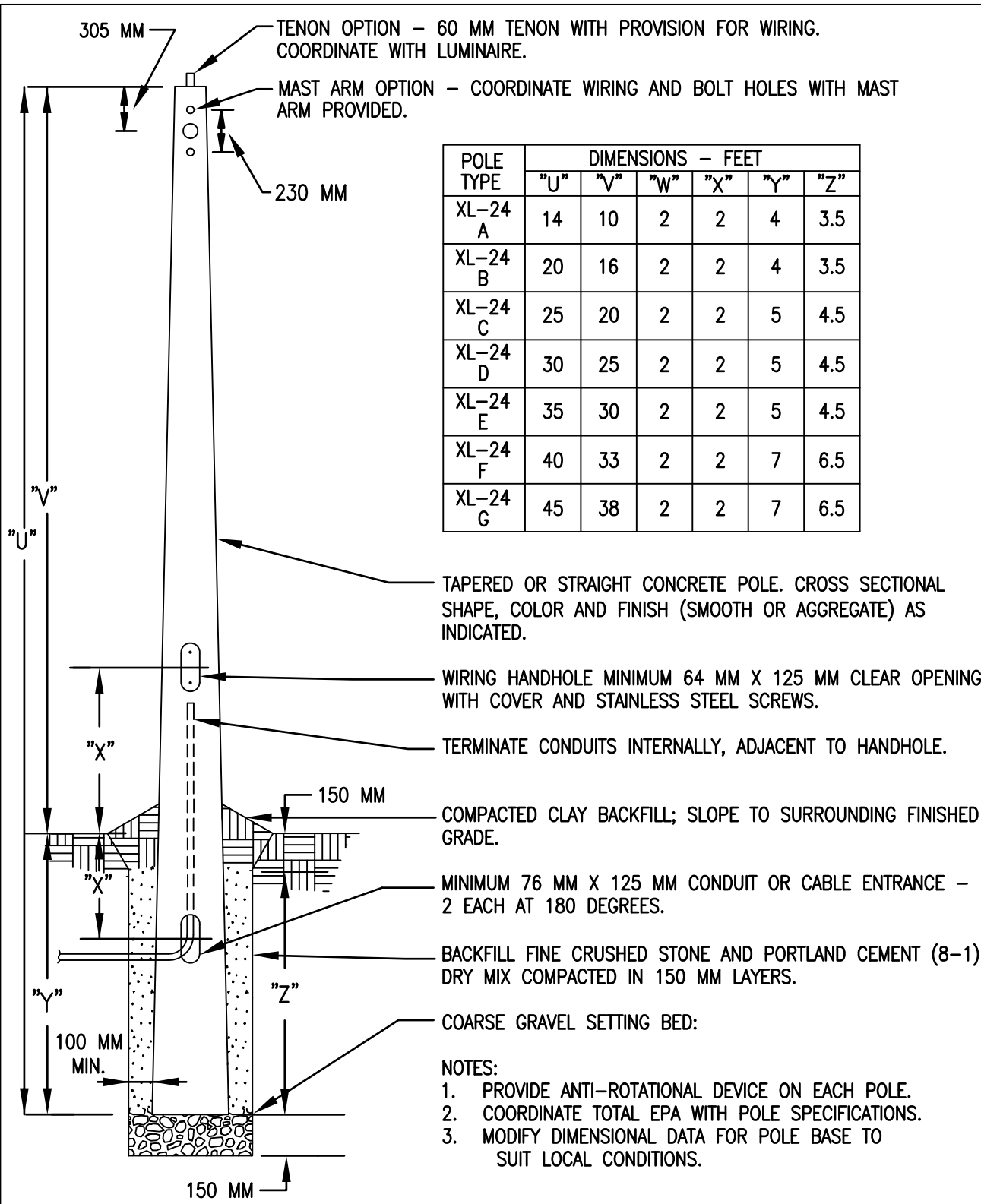

POLE TYPE	DIMENSIONS - FEET					
	"U"	"V"	"W"	"X"	"Y"	"Z"
XL-24 A	14	10	2	2	4	3.5
XL-24 B	20	16	2	2	4	3.5
XL-24 C	25	20	2	2	5	4.5
XL-24 D	30	25	2	2	5	4.5
XL-24 E	35	30	2	2	5	4.5
XL-24 F	40	33	2	2	7	6.5
XL-24 G	45	38	2	2	7	6.5

TAPERED OR STRAIGHT CONCRETE POLE. CROSS SECTIONAL SHAPE, COLOR AND FINISH (SMOOTH OR AGGREGATE) AS INDICATED.

WIRING HANDHOLE MINIMUM 64 MM X 125 MM CLEAR OPENING WITH COVER AND STAINLESS STEEL SCREWS.

TERMINATE CONDUITS INTERNALLY, ADJACENT TO HANDHOLE.

150 MM
 COMPACTED CLAY BACKFILL; SLOPE TO SURROUNDING FINISHED GRADE.

MINIMUM 76 MM X 125 MM CONDUIT OR CABLE ENTRANCE - 2 EACH AT 180 DEGREES.

BACKFILL FINE CRUSHED STONE AND PORTLAND CEMENT (8-1) DRY MIX COMPACTED IN 150 MM LAYERS.

COARSE GRAVEL SETTING BED:

- NOTES:
1. PROVIDE ANTI-ROTATIONAL DEVICE ON EACH POLE.
 2. COORDINATE TOTAL EPA WITH POLE SPECIFICATIONS.
 3. MODIFY DIMENSIONAL DATA FOR POLE BASE TO SUIT LOCAL CONDITIONS.

DIRECT-SET CONCRETE POLE

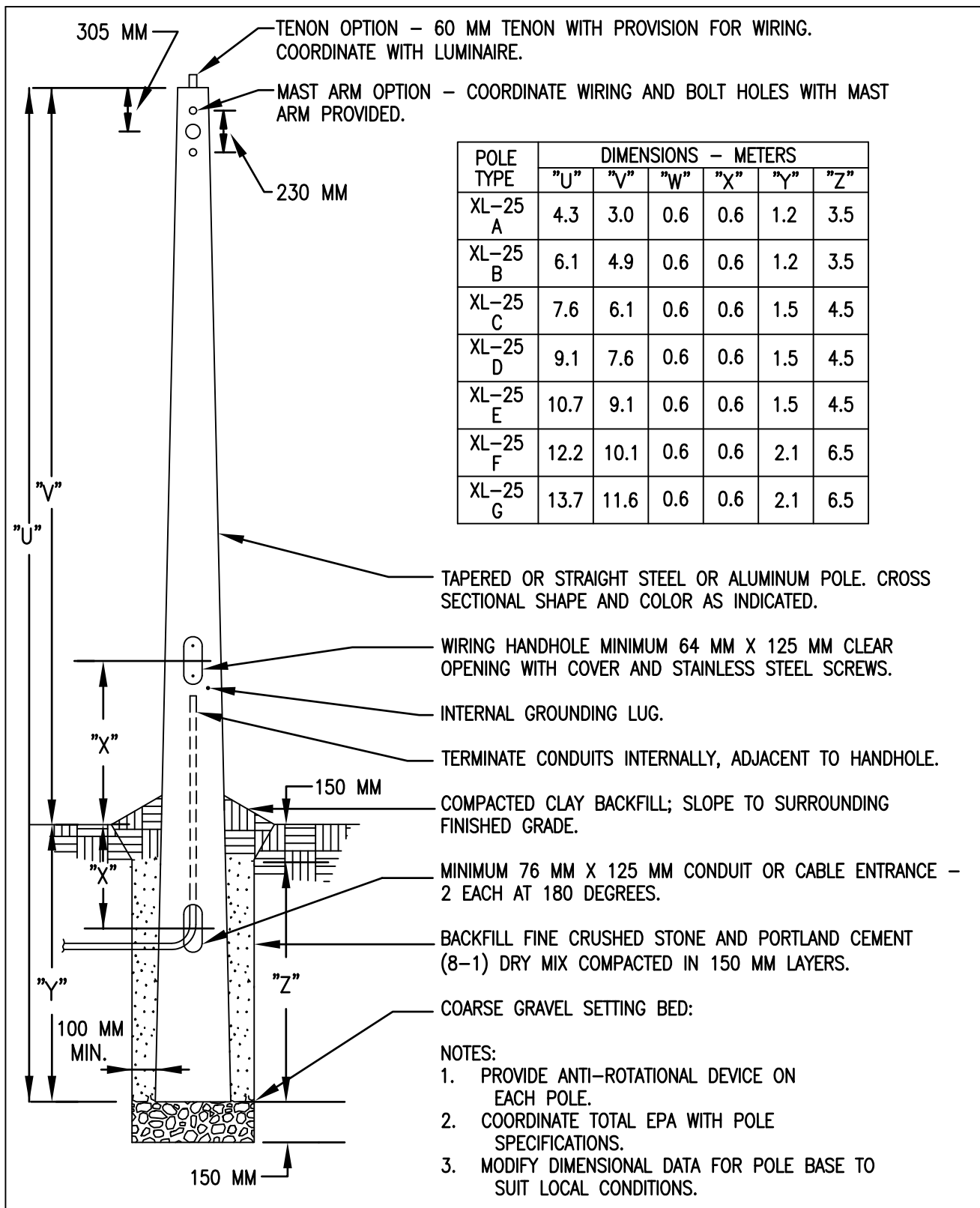

DIRECT-SET STEEL/ALUMINUM POLE

REVISED:

MARCH 2013

LUMINAIRE PLATE:

XL-25

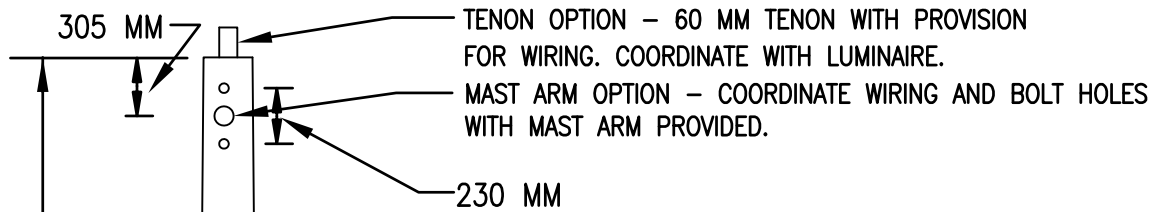

POLE TYPE	DIM "U"
XL-26 A	3.7
XL-26 B	6.1
XL-26 C	7.6
XL-26 D	9.1
XL-26 E	10.7
XL-26 F	12.2
XL-26 G	13.7

"U"

TAPERED OR STRAIGHT FIBERGLASS POLE. CROSS SECTIONAL SHAPE AND COLOR AS INDICATED.

NOTES:

COORDINATE TOTAL EPA WITH SPECIFICATIONS.

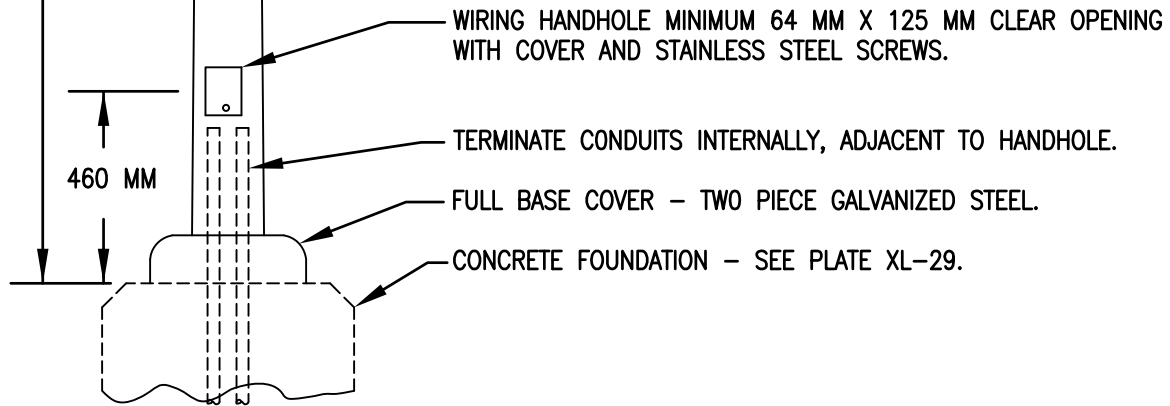

ANCHOR BASE FIBERGLASS POLE

REVISED:

MARCH 2013

LUMINAIRE PLATE:

XL-26

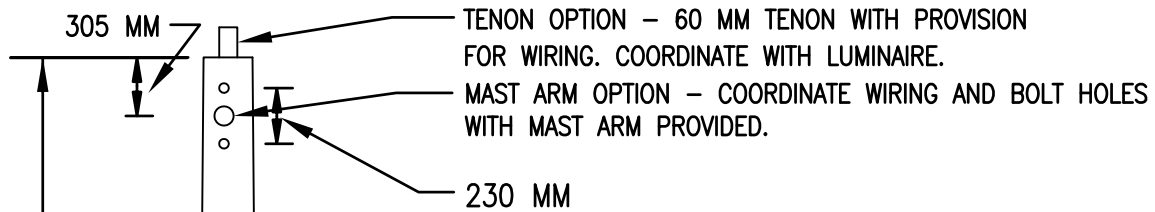

POLE TYPE	DIM "U"
XL-26 A	3.7
XL-26 B	6.1
XL-26 C	7.6
XL-26 D	9.1
XL-26 E	10.7
XL-26 F	12.2
XL-26 G	13.7

"U"

TAPERED OR STRAIGHT STEEL OR ALUMINUM POLE. CROSS SECTIONAL SHAPE AND COLOR AS INDICATED.

NOTES:

COORDINATE TOTAL EPA WITH SPECIFICATIONS.

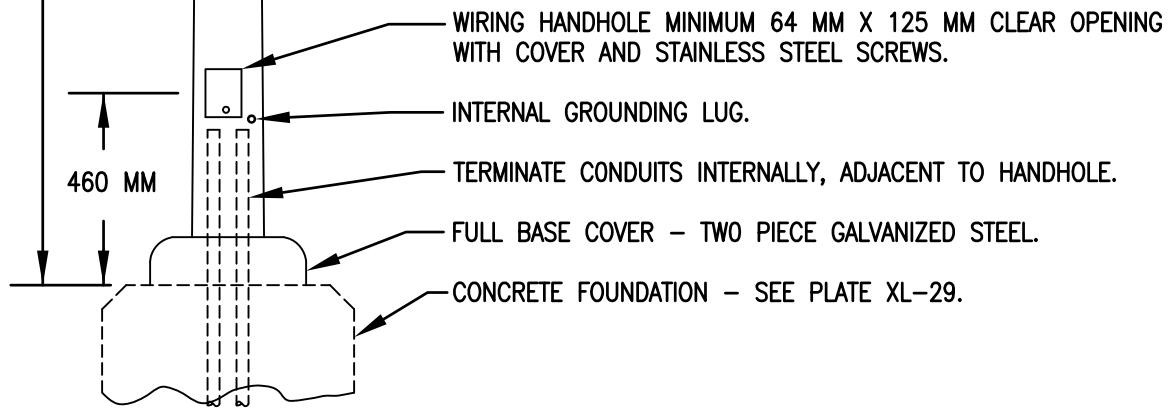

ANCHOR BASE STEEL/ALUMINUM POLE

REVISED:

MARCH 2013

LUMINAIRE PLATE:

XL-27

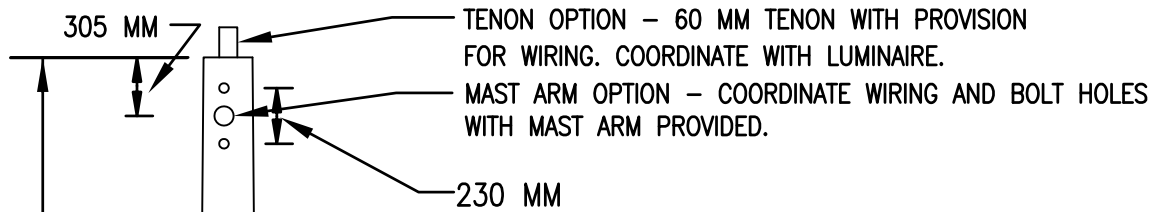

POLE TYPE	DIM "U"
XL-26 A	3.7
XL-26 B	6.1
XL-26 C	7.6
XL-26 D	9.1
XL-26 E	10.7
XL-26 F	12.2
XL-26 G	13.7

"U"

TAPERED OR STRAIGHT CONCRETE POLE. CROSS SECTIONAL SHAPE, COLOR AND FINISH (SMOOTH OR AGGREGATE) AS INDICATED.

NOTES:

COORDINATE TOTAL EPA WITH SPECIFICATIONS.

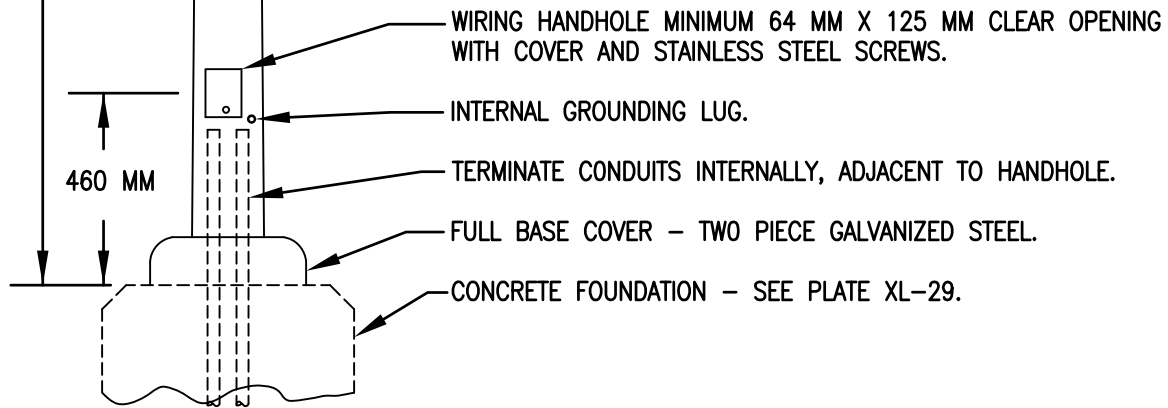

ANCHOR BASE CONCRETE POLE

REVISED:

MARCH 2013

LUMINAIRE PLATE:

XL-28

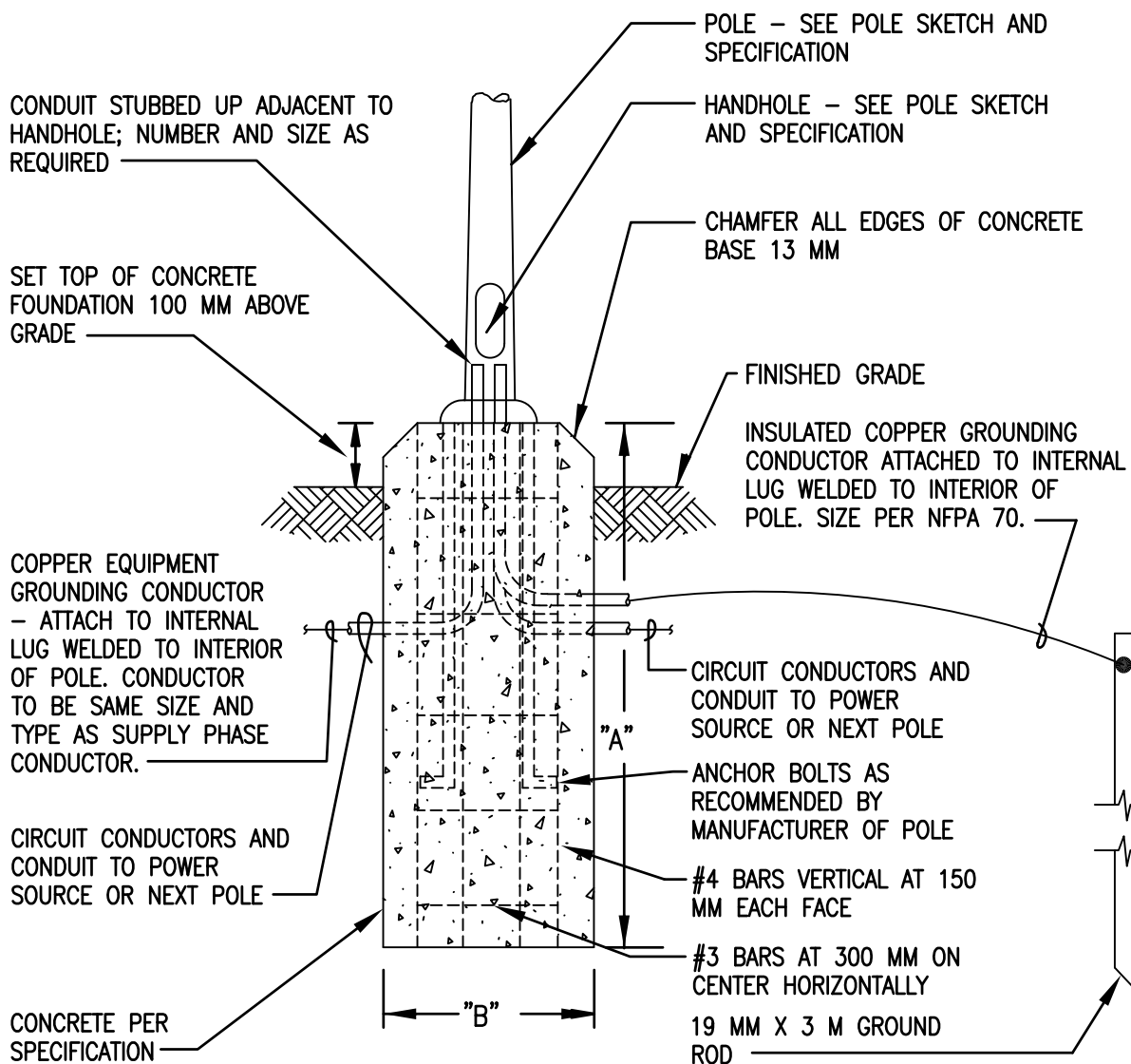

POLE HEIGHT	A	B
2.4-3.7 M	.9 M	.3 M
3.9-6.1 M	1 M	.4 M
6.4-9.1 M	1.8 M	.6 M
9.5-12.2 M	2 M	.7 M

ANCHOR BASE POLE FOUNDATION

REVISED:

MARCH 2013

LUMINAIRE PLATE:

XL-29

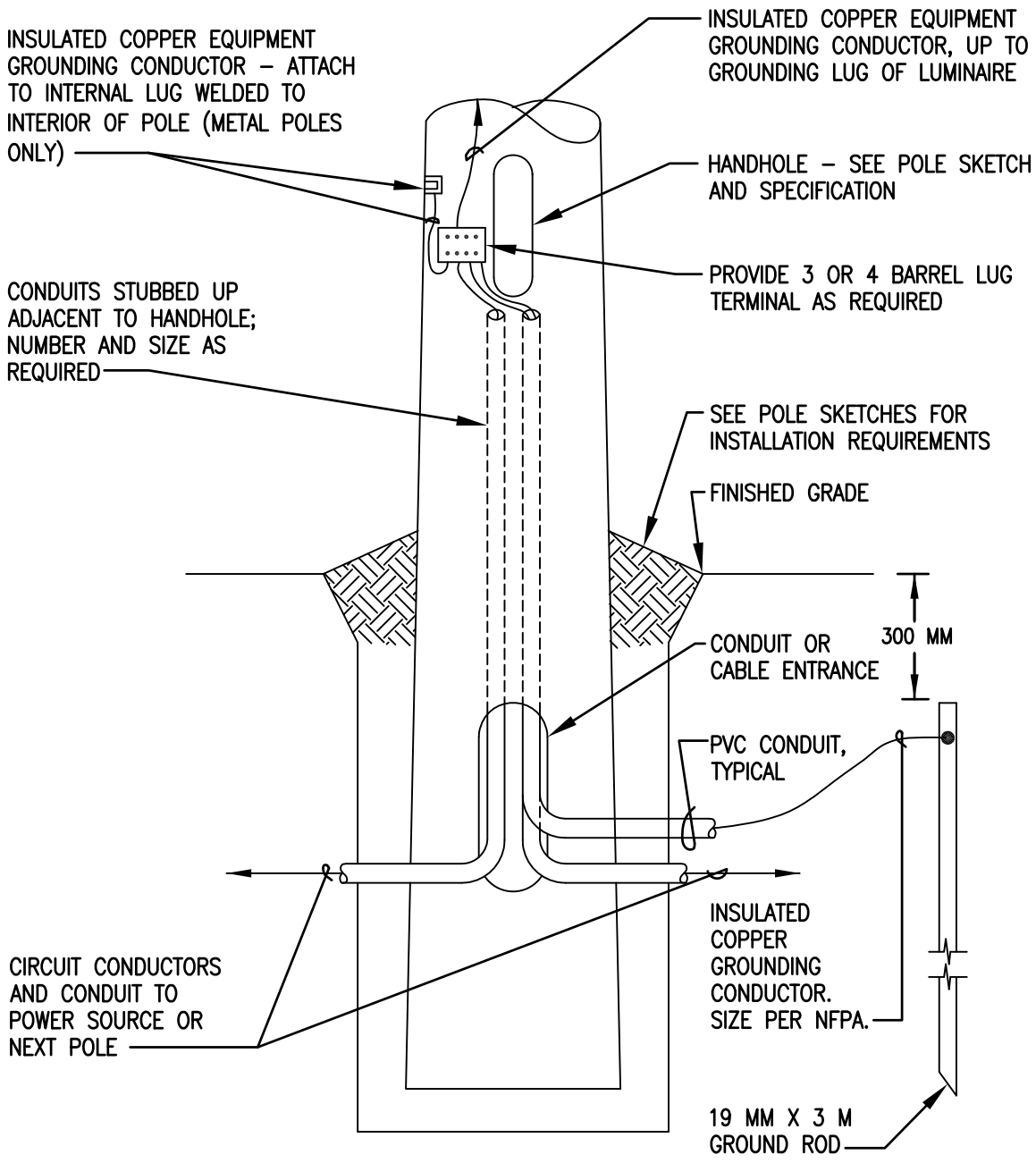

DIRECT SET POLE GROUNDING DETAIL

REVISED:

MARCH 2013

LUMINAIRE PLATE:

XL-30

RECTANGULAR ALUMINUM
EXTRUSION, APPROXIMATELY
60 MM X 125 MM

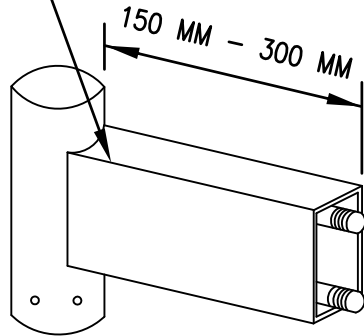

SINGLE ARM MOUNTING "A"
(TENON MOUNT SHOWN)

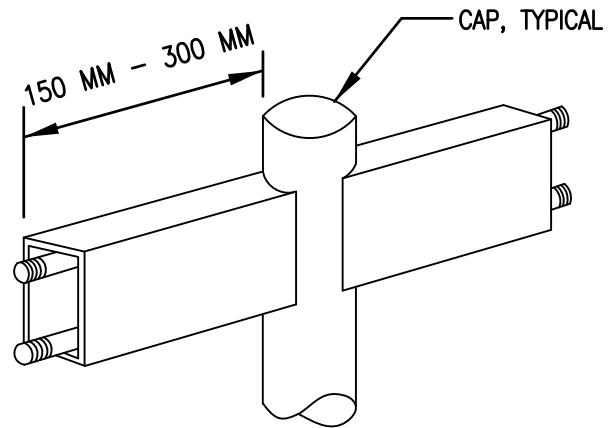

DOUBLE ARM MOUNTING "B"
(MAST ARM MOUNT SHOWN)

ROUND POLE APPLICATION

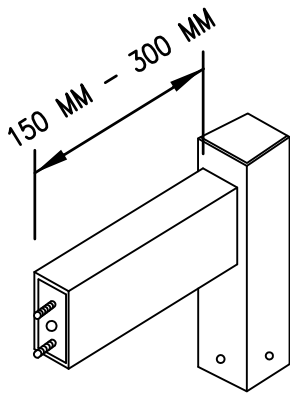

SINGLE ARM MOUNTING "C"
(TENON MOUNT SHOWN)

13 MM DIA.
THREADED RODS,
TYPICAL

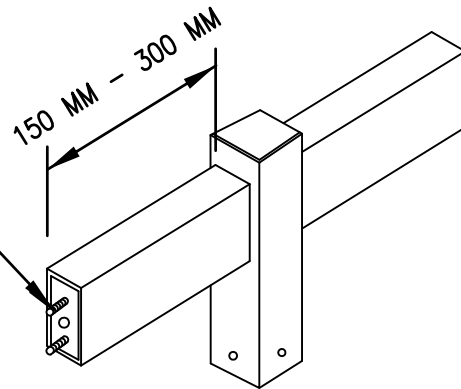

DOUBLE ARM MOUNTING "D"
(TENON MOUNT SHOWN)

SQUARE POLE APPLICATION

- NOTES:
1. ALL FASTENERS SHALL BE CONCEALED.
 2. ALL ARMS ARE AVAILABLE IN TENON OR MAST ARM MOUNTING; SPECIFY TYPE DESIRED.

LUMINAIRE MOUNTING ARM DETAILS

REVISED:

MARCH 2013

LUMINAIRE PLATE:

XL-31

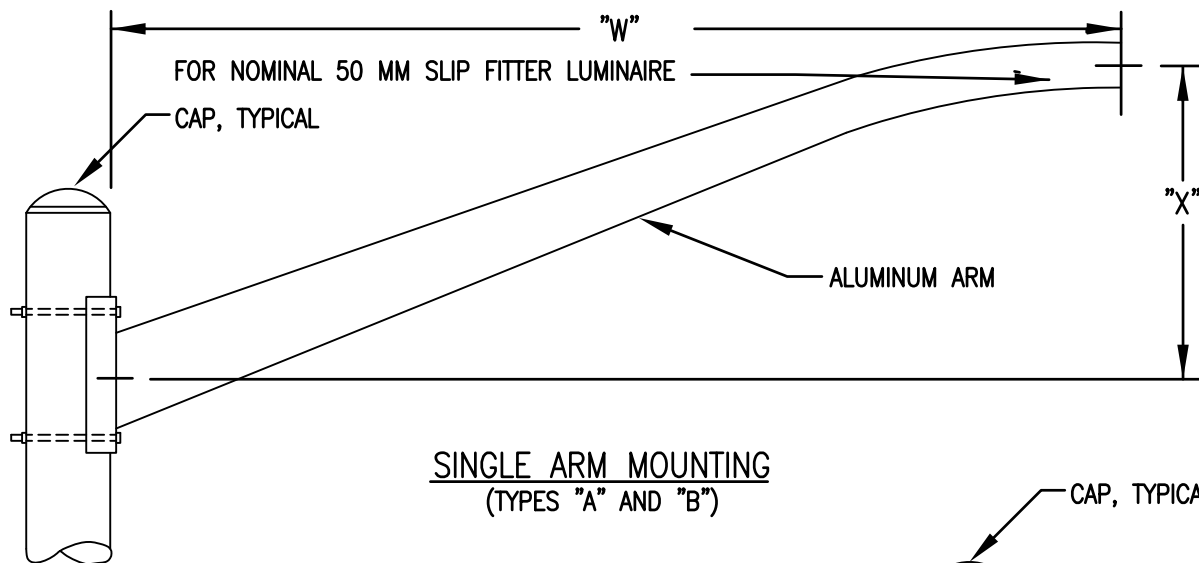

SINGLE ARM MOUNTING
(TYPES "A" AND "B")

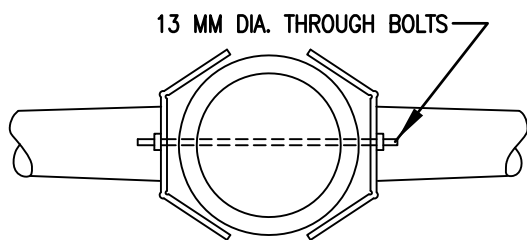

PLAN VIEW

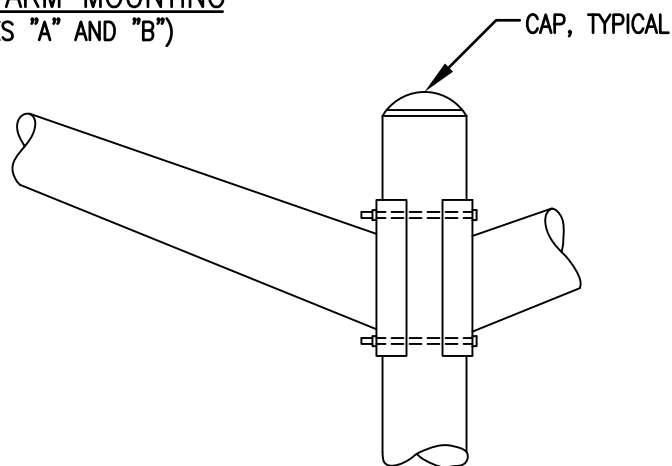

DOUBLE ARM MOUNTING
(TYPES "C" AND "D")

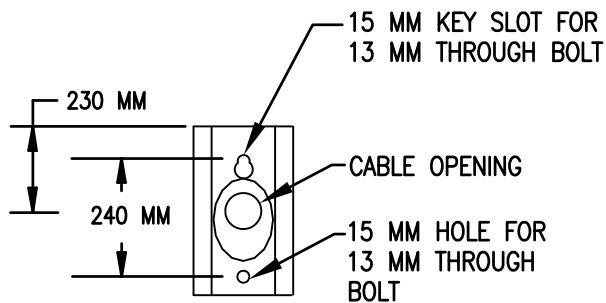

MOUNTING PLATE

MOUNTING ARM DIMENSIONS		
TYPE	"W"	"X"
XL-32, A	1.2 M	.4 M
XL-32, B	1.8 M	.6 M
XL-32, C	1.2 M	.4 M
XL-32, D	1.8 M	.6 M

NOTE: ALL MOUNTING HARDWARE FOR ARMS SHALL BE HOT-DIP GALVANIZED.

LUMINAIRE MOUNTING ARM DETAILS

REVISED:

MARCH 2013

LUMINAIRE PLATE:

XL-32

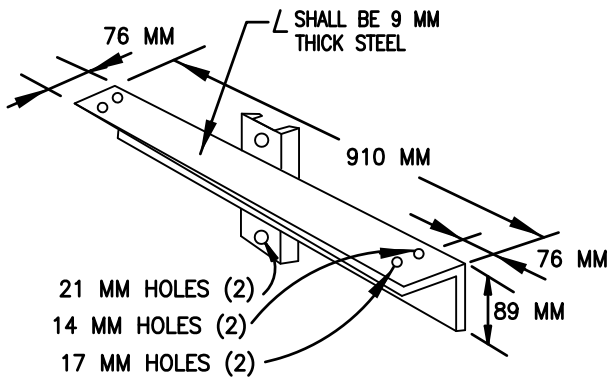

TWIN LUMINAIRE MOUNTING BRACKET - "A"

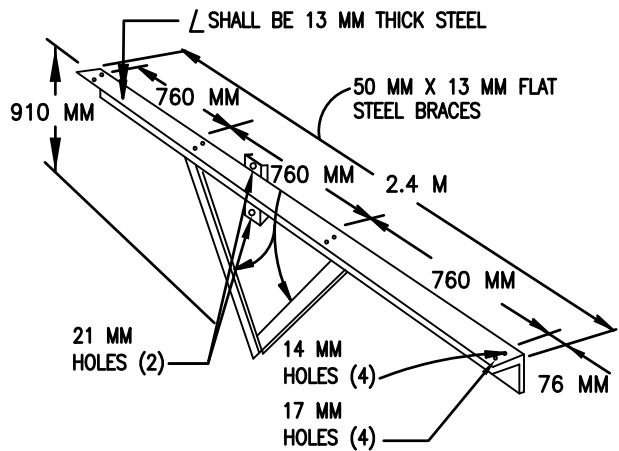

QUAD LUMINAIRE MOUNTING BRACKET - "B"

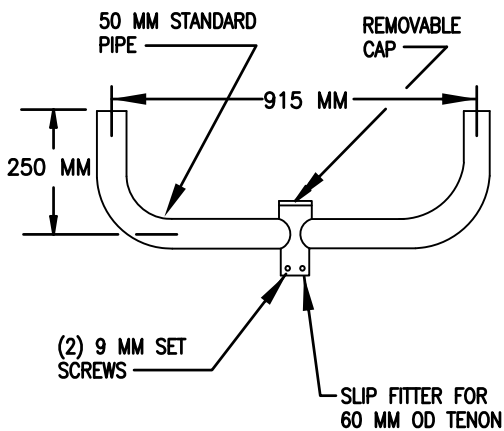

TWIN LUMINAIRE PIPE MOUNTING BRACKET - "C"

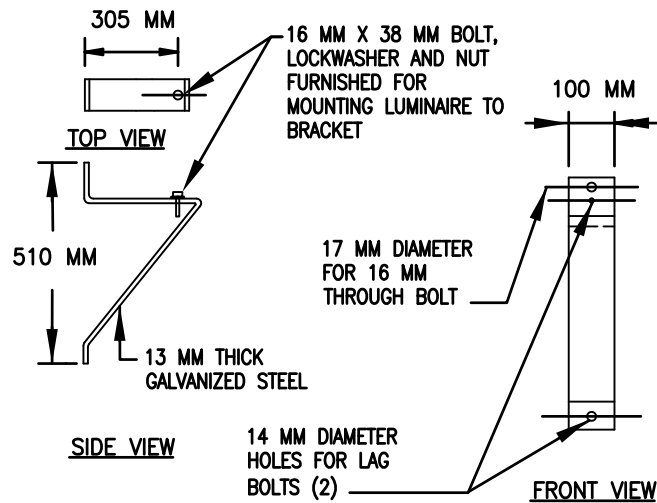

STEEL ANGLE SINGLE LUMINAIRE MOUNTING BRACKET FOR WALL OR POLE - "D"

NOTES: ALL MATERIAL SHOWN ON THIS SHEET SHALL BE HOT-DIP GALVANIZED.
PROVIDE BOLTS AND OTHER HARDWARE AS REQUIRED.

LUMINAIRE MOUNTING BRACKET DETAILS

REVISED:

MARCH 2013

LUMINAIRE PLATE:

XL-33

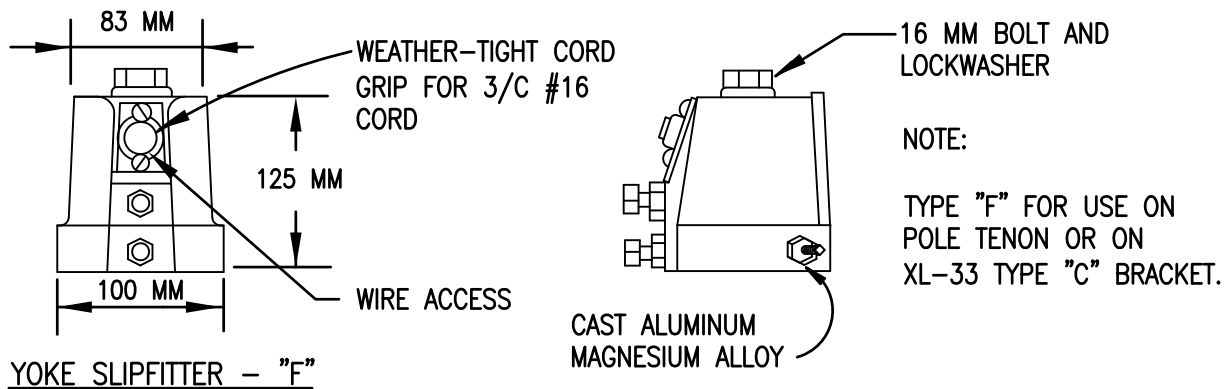
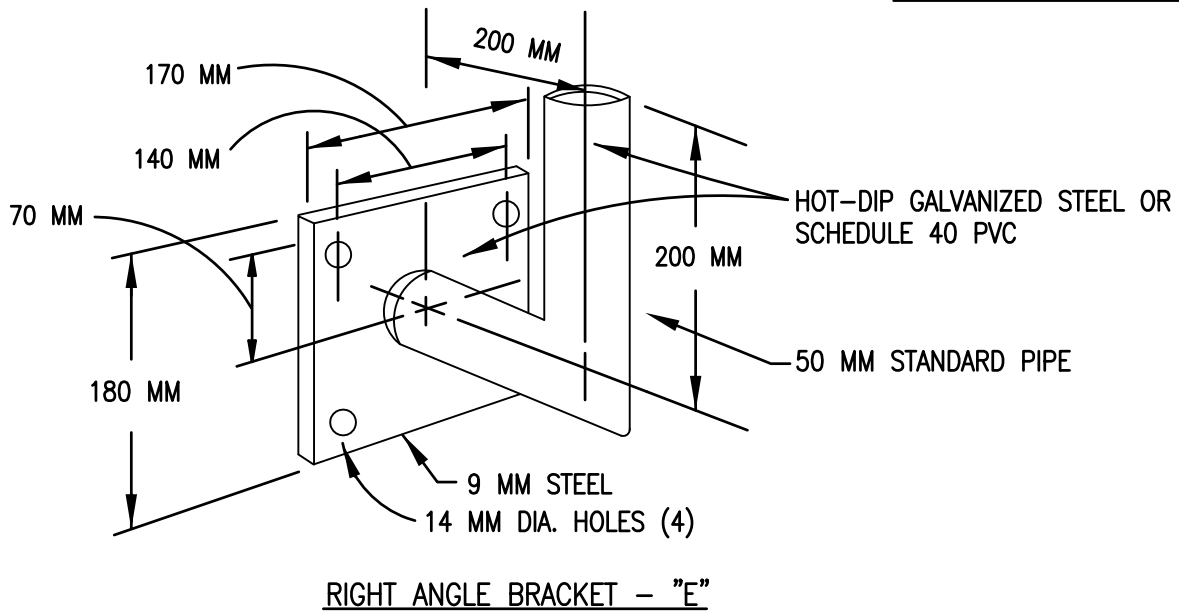
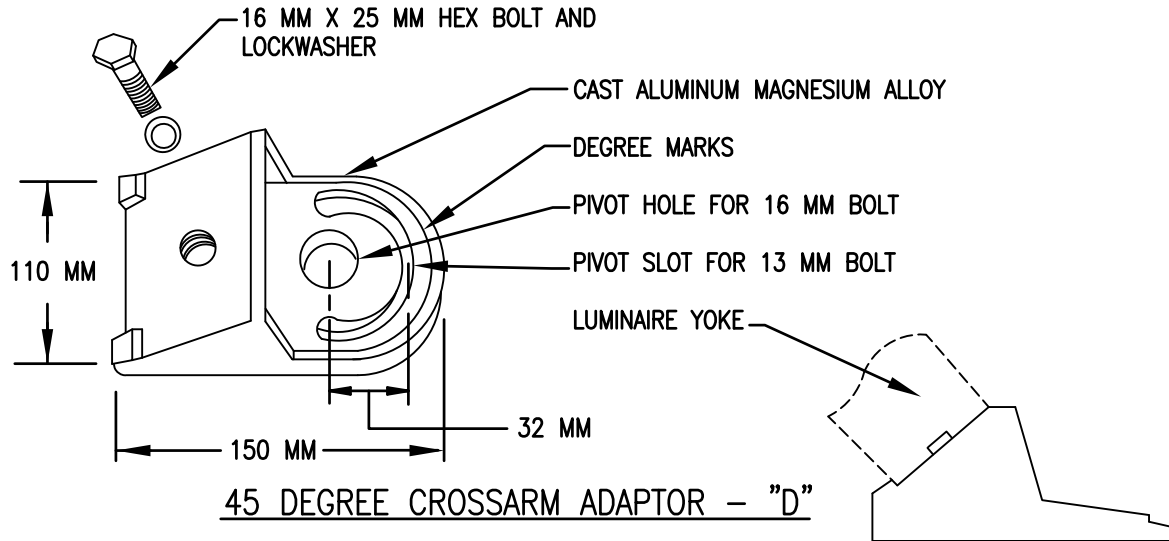

LUMINAIRE MOUNTING BRACKET DETAILS

REVISED:

MARCH 2013

LUMINAIRE PLATE:

XL-34