

PPV PROJECT IDENTIFICATION SIGNBOARD

SCALE: 3/4" = 1'-0"

PLATE 1

4'-0" [1220mm]

MITERED CORNER

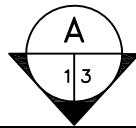

4"x4" [89mmx89mm] PRESSURE TREATED POST; COLOR OF POST AND STRIPES DETERMINED BY PRIVATE PARTNER.

PRIVATE COMPANY NAME AND LOGO BY PRIVATE PARTNER. SIZE, STYLE, COLORS DETERMINED BY PRIVATE PARTNER.

PRIVATE COMPANY NAME AND LOGO

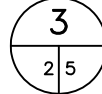

NAME OF PROJECT

PAINTED FIELD; COLOR, 'WHITE'

NAME OF PROJECT, ARCHITECT AND CONTRACTOR. PRIVATE PARTNER TO DETERMINE SIZE, STYLE AND COLOR OF LETTERING.

COLOR RENDERING OF PROJECT FRAMED UNDER GLASS (WEATHERPROOF). SIZE DETERMINED BY PRIVATE PARTNER.

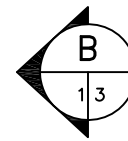

PAINTED 3.5" [89mm] STRIPE; COLOR TO MATCH POST

ARCHITECT

CONTRACTOR

9.5"x11.25"[240mmX286mm] NAVFAC LOGO AVAIL: https://portal.navfac.navy.mil/portal/page?_pageid=181,3465071&_dad=portal&_schema=PORTAL

8'-0" [2440mm]

11.25 [286mm] DIAMETER CNIC OR USMC LOGO AVAIL: https://portal.navfac.navy.mil/portal/page?_pageid=181,3465071&_dad=portal&_schema=PORTAL

2.5" [64mm] LETTERING CENTERED



CNIC (or USMC) & NAVFAC

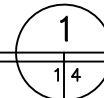

2" [50mm] LETTERING CENTERED

PAINTED 3.5" [89mm] STRIPE; COLOR TO MATCH POST

COMPONENT NAME (i.e. MIDLANT)

4x4 [89mmx89mm] PRESSURE TREATED POST BEYOND; COLOR: 'WHITE'

1'-8" [510mm]

NOTES:

1. PAINT ALL OTHER WOOD SURFACES WITH ONE COAT EXT. PRIMER AND TWO COATS GLOSS WHITE ENAMEL.
2. ALL LETTERING SHALL BE EVENLY SPACED.
3. LETTER STYLE, 'ARIAL', COLOR 'DARK BLUE'. TYPICAL FOR ALL GOV'T DIRECTED LETTERING IN LOWER SECTION.

GROUND LEVEL

1'-0" [300mm]

3'-0" [915mm]

PPV PROJECT IDENTIFICATION SIGNBOARD

SCALE: 3/4" = 1'-0"

PLATE 2 - OPTIONAL RENDERING

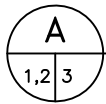
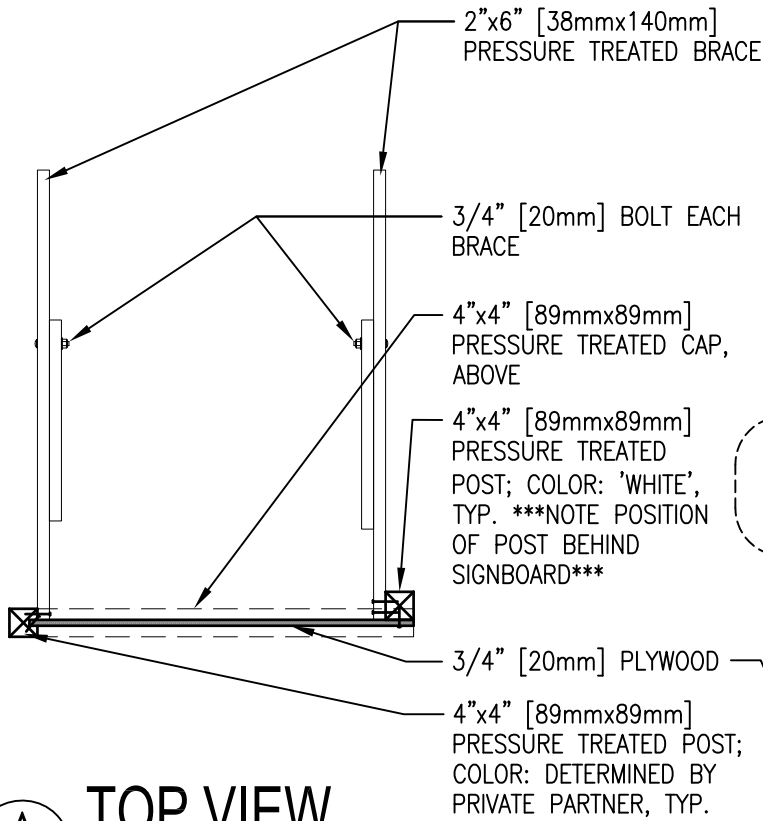

TOP VIEW

SCALE: 1/2" = 1'-0"

NOTES:

1. POSTS AND BRACES SHALL BE PRESSURE TREATED.
2. ALL FASTENERS SHALL BE ZINC COATED.
3. INCLUDE OPTIONAL BRACING IN UNSTABLE SOIL OR HIGH WIND ENVIRONMENTS.

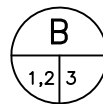
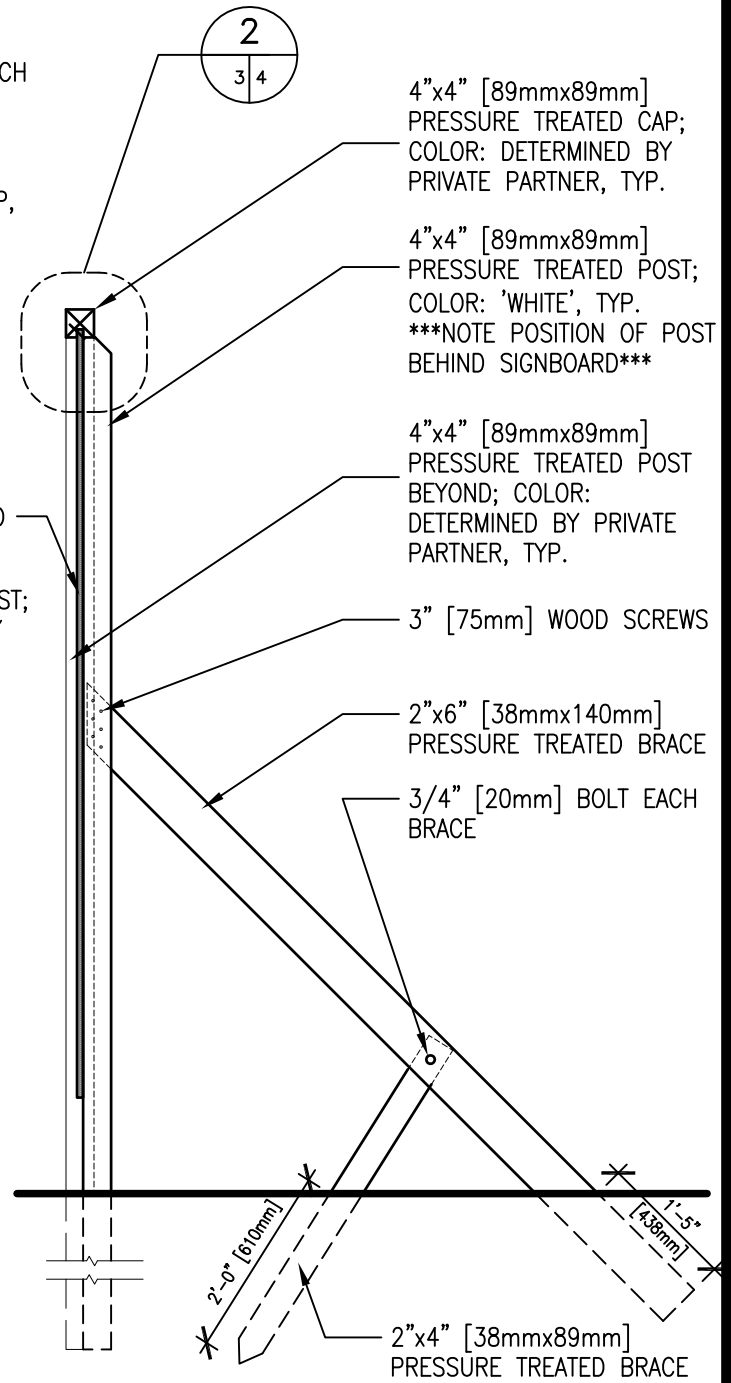

SIDE VIEW

SCALE: 1/2" = 1'-0"

PPV PROJECT IDENTIFICATION SIGNBOARD SUPPORT DETAILS

4"x4" [89mmx89mm] PRESSURE TREATED POST; COLOR: 'WHITE',
TYP. ***NOTE POSITION OF POST BEHIND SIGNBOARD***

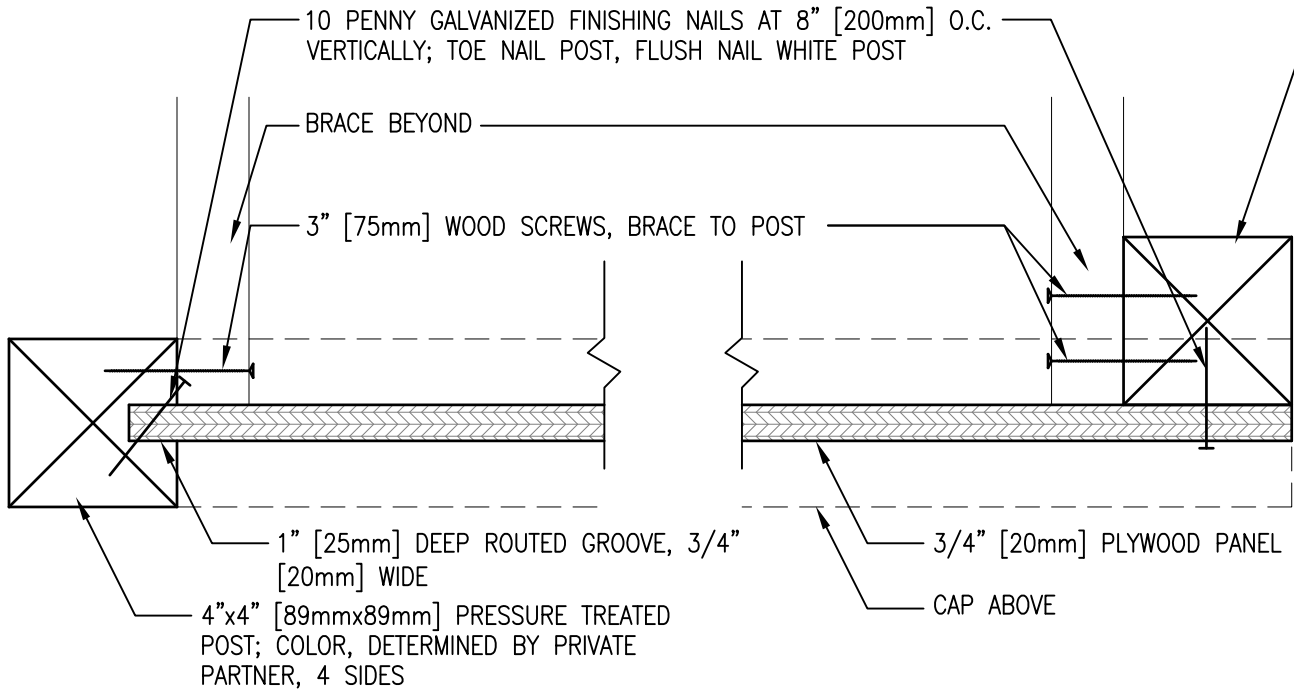

1
1,2 4

PLAN SECTION

SCALE: 3" = 1'-0"

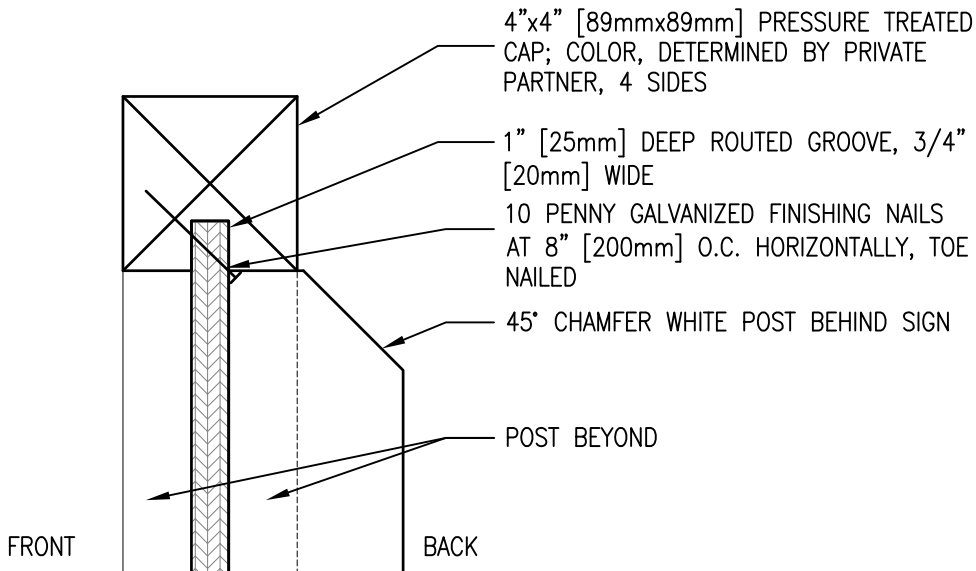

2
1,2 4

SECTION AT TOP

SCALE: 3" = 1'-0"

PPV PROJECT IDENTIFICATION SIGNBOARD SECTIONS

PLATE 4

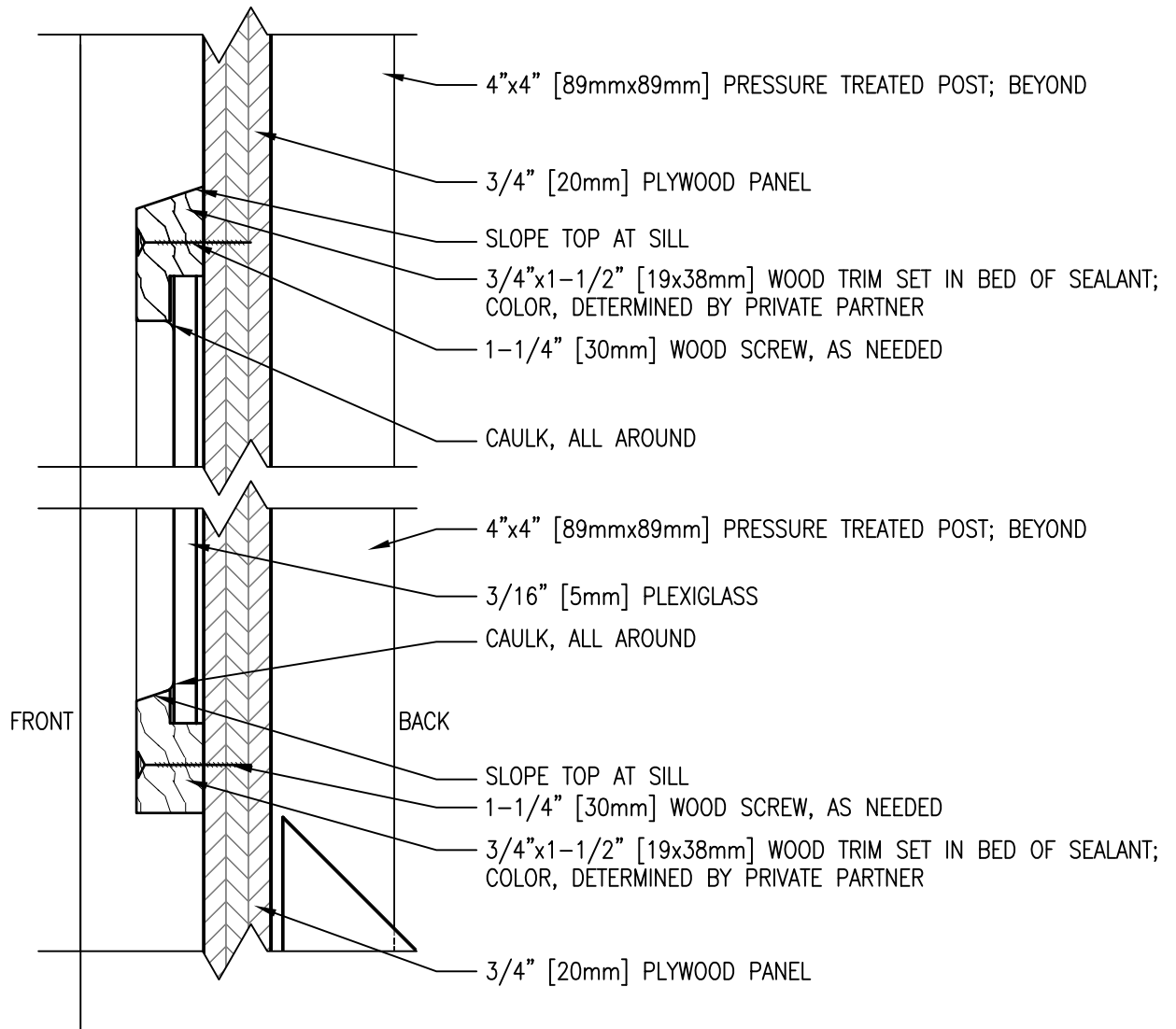

3
2/5

SECTION AT RENDERING FRAME

SCALE: 6" = 1'-0"

PPV PROJECT IDENTIFICATION SIGNBOARD SECTION

PLATE 5