

UNIFIED FACILITIES CRITERIA (UFC)

RESILIENT INSTALLATION MICROGRID DESIGN



APPROVED FOR PUBLIC RELEASE; DISTRIBUTION UNLIMITED

This Page Intentionally Left Blank

UNIFIED FACILITIES CRITERIA (UFC)

RESILIENT INSTALLATION MICROGRID DESIGN

Any copyrighted material included in this UFC is identified at its point of use. Use of the copyrighted material apart from this UFC must have the permission of the copyright holder.

Indicate the Military Department Preparing Activity responsible for the document.

U.S. ARMY CORPS OF ENGINEERS

NAVAL FACILITIES ENGINEERING SYSTEMS COMMAND (Preparing Activity)

AIR FORCE CIVIL ENGINEER CENTER

Record of Changes (changes are indicated by \1\ ... /1/)

Change No.	Date	Location
1	12/16/25	Spelling and grammar corrections throughout. Paragraph 1-9 applies to system modifications. Table 1-1 adds SMR and drops climate change. Paragraph 2-1 clarifies independent generation sources. Paragraph 3-1 allows AHJ to consider fuel deliveries. Paragraph 4-2.1.6 describes temporary metering. Paragraph 4-4 includes construction sequencing details. Paragraph 6-1.5 adds load control logic for re-sync. Paragraph 6-1.6 adds a note about full system testing.



This Page Intentionally Left Blank

FOREWORD

The Unified Facilities Criteria (UFC) system is prescribed by MIL-STD 3007 and provides planning, design, construction, sustainment, restoration, and modernization criteria, and applies to the Military Departments, the Defense Agencies, and the DoD Field Activities in accordance with [USD \(AT&L\) Memorandum](#) dated 29 May 2002. UFC will be used for all DoD projects and work for other customers where appropriate. All construction outside of the United States, its territories, and possessions is also governed by Status of Forces Agreements (SOFA), Host Nation Funded Construction Agreements (HNFA), and in some instances, Bilateral Infrastructure Agreements (BIA). Therefore, the acquisition team must ensure compliance with the most stringent of the UFC, the SOFA, the HNFA, and the BIA, as applicable.

UFC are living documents and will be periodically reviewed, updated, and made available to users as part of the Military Department's responsibility for providing technical criteria for military construction. Headquarters, U.S. Army Corps of Engineers (HQUSACE), Naval Facilities Engineering Systems Command (NAVFAC), and Air Force Civil Engineer Center (AFCEC) are responsible for administration of the UFC system. Technical content of UFC is the responsibility of the cognizant DoD working group. Defense Agencies should contact the respective DoD Working Group for document interpretation and improvements. Recommended changes with supporting rationale may be sent to the respective DoD working group by submitting a Criteria Change Request (CCR) via the Internet site listed below.

UFC are effective upon issuance and are distributed only in electronic media from the following source:

- Whole Building Design Guide web site <http://www.wbdg.org/ffc/dod>.

Refer to UFC 1-200-01, *DoD Building Code*, for implementation of new issuances on projects.

AUTHORIZED BY:



PETE G. PEREZ, P.E., SES
Chief, Engineering and Construction
U.S. Army Corps of Engineers

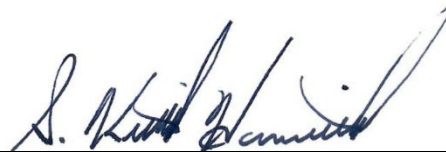

S. KEITH HAMILTON, P.E., SES
Chief Engineer and Director
Planning, Design and Construction
Naval Facilities Engineering Systems Command



DAVID H. DENTINO, SES
Deputy Director of Civil Engineers
DCS/Logistics, Engineering &
Force Protection (HAF/A4C)
HQ United States Air Force



MICHAEL McANDREW, SES
Deputy Assistant Secretary of Defense
(Construction)
Office of the Secretary of Defense

This Page Intentionally Left Blank

TABLE OF CONTENTS

CHAPTER 1 INTRODUCTION	1
1-1 GENERAL	1
1-2 BACKGROUND	1
1-3 PURPOSE AND SCOPE	2
1-4 APPLICABILITY	3
1-5 MICROGRID POINTS OF CONTACT BY SERVICE	3
1-6 GENERAL BUILDING REQUIREMENTS	3
1-7 ENERGY RESILIENCE	3
1-8 OWNERSHIP AND SUSTAINMENT	4
1-9 CYBERSECURITY	4
1-10 TOPOLOGY	4
1-10.1 Distributed Systems	5
1-10.2 Central Plant Systems	6
1-10.3 Fuel-Based, Dispatchable (Firm) Generation	7
1-10.4 Inverter-Based Generation	7
1-11 ENERGY RESOURCE CLASSIFICATION GUIDE	7
1-12 PROGRAMMING	8
1-13 GLOSSARY	8
1-14 REFERENCES	8
CHAPTER 2 TECHNICAL REQUIREMENTS	11
2-1 MINIMUM DESIGN REQUIREMENTS	11
2-2 PERFORMANCE REQUIREMENTS	12
2-2.1 Autonomous Operation	12
2-2.2 Safety and Grounding	12
2-2.3 Cybersecurity and Risk Management Framework	13
2-2.4 Utility Management Control System (UMCS) Integration	14
CHAPTER 3 PERFORMANCE METRICS	15
3-1 OFF-GRID SYSTEM ENDURANCE	15
3-2 PEAK CRITICAL LOAD SERVED	15
3-3 LOAD SHEDDING	15
3-4 RESTORATION TIME AND SOFT TRANSITION	16

3-5	OPTIMIZED DER LOAD FACTOR.....	16
3-6	ENERGY SURETY AND REDUNDANCY.....	16
3-7	DEGREE OF RENEWABLE ENERGY CONTRIBUTION.....	16
3-8	OPERATIONAL VISIBILITY AND GRAPHICAL INTERFACE.....	17
3-9	EXPANDABILITY AND RECONFIGURABILITY.....	17
3-10	GRID-CONNECTED AND ECONOMIC APPLICATIONS.....	17
3-11	POWER QUALITY.....	18
CHAPTER 4 PLANNING, DESIGN AND ACQUISITION		19
4-1	MICROGRID PERFORMANCE-BASED PLANNING AND DESIGN.....	19
4-1.1	Performance-Based Planning and Design Process.....	19
4-1.2	Checklist for Compiling a Planning DD1391.....	20
4-1.3	Methods of Procurement.....	20
4-1.4	Construction Sequencing.....	21
4-2	PLANNING AND MODELING (0-10%).....	21
4-2.1	Conceptual Design Elements.....	22
4-3	PRELIMINARY DESIGN (10-15%).....	31
4-3.1	Preliminary Design Elements.....	31
4-4	DETAILED (ENGINEERING) DESIGN.....	33
4-4.1	Aligning Microgrid Operation with Existing Infrastructure.....	34
4-4.2	Aligning Generation Sources for Islanded Operation.....	34
4-4.3	Aligning Renewable Systems for Islanded Operation.....	34
4-4.4	Aligning Controls and Switchgear for Islanded Operation.....	35
4-4.5	Aligning Switches and Transformers.....	35
CHAPTER 5 COMMISSIONING AND PERFORMANCE VALIDATION		37
5-1	COMMISSIONING PLAN.....	37
5-2	DEVICE/COMPONENT LEVEL COMMISSIONING.....	38
5-3	SYSTEM-LEVEL COMMISSIONING.....	38
5-3.1	Identify Software/Hardware Configuration Changes.....	38
5-3.2	Validate Operational State.....	39
5-3.3	Periodic Reverification Testing.....	39
CHAPTER 6 SEQUENCE OF OPERATIONS		41
6-1	STATES OF OPERATION.....	41
6-1.1	Normal Operation (Grid-Connected, Standby).....	41

6-1.2	Isolation from External Utility.	41
6-1.3	Microgrid Formation.	42
6-1.4	Islanded Operation for Resilience and Endurance.....	43
6-1.5	Re-Synchronization Back to External Utility (Soft Transition Only).	44
6-1.6	Testing and Diagnostic Mode.	44
6-2	UTILITY CONSIDERATIONS.....	45
6-2.1	Utility Interconnection and Secure Islanding.	45
6-2.2	Commercial Utility Relations.	45
CHAPTER 7 OPERATIONS AND SUSTAINMENT CONSIDERATIONS		47
7-1	SYSTEM TRAINING.....	47
7-2	PERIODIC OPERATIONAL TESTING.....	48
APPENDIX A MICROGRID BACKGROUND INFORMATION		49
A-1	MICROGRIDS AND DOD INSTALLATION ENERGY POLICY.....	49
A-1.1	Executive Orders	49
A-2	LOAD CHARACTERIZATION USING AMI DATA.....	49
APPENDIX B ANALYSIS AND DESIGN MODELING TOOLS		51
B-1	ANALYSIS TOOLS.....	51
B-2	MICROGRID DESIGN MODELING TOOLS.....	51
B-2.1	Modeling Tool Requirements.....	52
B-2.2	Tools Reviewed.....	53
APPENDIX C CYBERSECURITY FOR MICROGRIDS		57
C-1	APPLYING RISK MANAGEMENT FRAMEWORK TO MICROGRID CONTROLS SYSTEMS	57
APPENDIX D LESSONS LEARNED AND EXAMPLES.....		59
D-1	LESSONS LEARNED.....	59
D-1.1	Acquisition Lessons Learned.....	59
D-1.2	Design Lessons Learned.....	59
D-1.3	Operations Lessons Learned.....	59
D-2	PROJECT EXAMPLES.....	61
D-2.1	Sample of DD1391.....	62
APPENDIX E DEMAND RESPONSE		65
E-1	CONTROL OF DEMAND CHARGES.....	65
E-2	POWER FACTOR CORRECTION.....	65

E-3	CONTRACT REVISION.....	65
E-3.1	On-Call Demand Reduction.....	65
E-3.2	Fixed Reduction on Preset Schedule.....	66
APPENDIX F SUPPLEMENTARY ELECTRICAL FAULT PROTECTION AND GROUNDING.....		67
F-1	ELECTRICAL SYSTEM PROTECTION.....	67
F-2	SYNCHRONIZATION.....	67
APPENDIX G GLOSSARY.....		69
G-1	ACRONYMS.....	69
G-2	DEFINITION OF TERMS.....	71
APPENDIX H REFERENCES.....		73
H-1	GOVERNMENT STANDARDS.....	73
H-2	NON-GOVERNMENT STANDARDS.....	74
H-3	OTHER RESOURCES.....	75

FIGURES

Figure 1-1	Components of a Microgrid.....	1
Figure 1-2	Layered Approach to Contingency Power.....	2
Figure 1-3	Distributed Generation Architecture.....	5
Figure 1-4	Normal and Emergency Switchgear Configuration Across ATS.....	5
Figure 4-1	The Microgrid Design Progression.....	20
Figure 4-2	Microgrid Boundary.....	22
Figure 4-3	Load Class Designations and Annual Down Time.....	23
Figure 4-4	Specific Energy vs. Specific Power for Storage DER Assets.....	29
Figure F-1	Interconnection and Protection on Transformer.....	68

TABLES

Table 1-1	DER Attributes.....	9
Table 4-1	Microgrid Modeling Tools Vs Power System Analysis Tools.....	25
Table 4-2	Facility Designation in Microgrid System.....	26
Table 4-3	Energy Storage-based DER (as of January 2023).....	32
Table B-1	Microgrid Design Tools & Section 2911 Requirement Status.....	55
Table D-1	Example SAIDI/SAIFI Reliability Numbers.....	63

CHAPTER 1 INTRODUCTION

1-1 GENERAL.

The primary objective of networked standby power systems (e.g., microgrids) is to deliver resilient, ride-through power to installation operations during extended contingencies resulting from commercial service failure, natural disaster, or cyber-attack. Microgrid systems deliver contingency power to loads inside a facility, a facility cluster, several facilities on a feeder(s), across a substation(s), or an entire installation campus. Islanded operation is a fundamental characteristic of all microgrid designs governed by this document. A microgrid's primary benefit is its ability, as a bounded system, to disconnect from the commercial grid during an emergency and deliver resilient, ride-through power with optimized off-grid endurance. Figure 1-1 shows components of a microgrid.

Figure 1-1 Components of a Microgrid

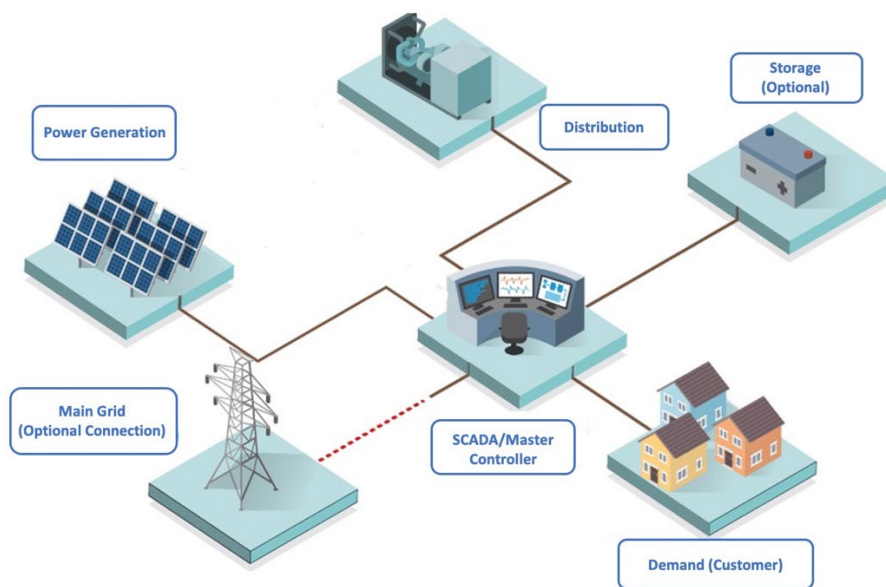

1-2 BACKGROUND.

Facility-dedicated backup power architectures represent DoD's de-facto approach to backing up mission loads during commercial power outages, in accordance with UFC 3-540-01. This approach has several noteworthy advantages: relative simplicity of operation (mission-dedicated generation supports specific mission loads), clear demarcation of real property ownership, and limited ambiguity of sustainment cost share (a tenant or mission owner generally maintains that facility's backup generator). However, such load-dedicated standby power solutions can be ill-suited to carry critical operations over extended periods of time (each load is completely dependent on its mated facility generator, and increasing redundancy at each load requires additional

infrastructure at each load). Further, such solutions offer limited ability to interconnect and leverage large renewable energy systems (or exploit their sustainability and economic benefit), as modestly sized facility generators may be subject to extremely high ramp rates, load-following conditions, and power quality variability when networked with large renewable systems. Finally, cyber-securing each of the IP-addressable assets and controllers in a facility dedicated standby environment is generally costlier and laborious than securing a single, large, centralized utility monitoring and control system.

Microgrids and networked standby power systems deliver a complementary solution supporting a layered framework for contingency power (see Figure 1-2). Using this approach, each layer of contingency power relieves the power system in the layer below. Accordingly, when the microgrid is active, mission-dedicated assets are relieved by the network, allowing the installation to maintain a more unified and resilient standby power posture.

Figure 1-2 Layered Approach to Contingency Power

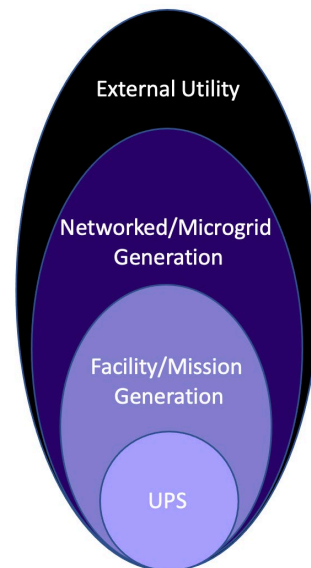

Multi-Layered Approach to Contingency Power

1-3 PURPOSE AND SCOPE.

This Unified Facilities Criteria (UFC) provides criteria on installation microgrid design requirements, performance metrics to inform design, sequence of operations, commissioning and validation, and sustainment. Design tenets and criteria contained herein are intended to ensure resilient, robust, and standardized solutions based on performance-based criteria and best design practices.

1-4 APPLICABILITY.

This UFC is applicable to all networked “islandable” standby power systems (systems capable of isolating and operating independently from the external grid). Compliance with this UFC is mandatory for the planning, design, construction, and commissioning of networked standby power systems, including microgrids for facilities and installations, regardless of funding source. This UFC also applies to overseas facilities, considering mission objectives and Host Nation standards, to the greatest extent practicable. This criteria addresses both prime and continuous power application under islanded and grid-connected conditions of operation. This guidance does not forego adherence to prevailing guidance for stationary engine-drive power systems as stated in UFC 3-540-01. Whenever unique conditions and problems are not specifically addressed by this UFC, use the applicable referenced industry standards and other documents for design guidance.

Per DoD Instruction 4270.5, the design criteria of this UFC does not apply to privatized housing or to projects acquired through a real property exchange agreement. This guidance is not applicable or intended to address mobility power system or mobile generation solutions. This UFC is not applicable to individual facility or load-dedicated standby power systems.

1-5 MICROGRID POINTS OF CONTACT BY SERVICE.

For any DoD project involving networked standby power or microgrid design, the relevant agency for each service must be contacted as soon as possible. Information, design support, system modeling, and other assistance is available from the following organizations:

- **Army:** US Army Corps of Engineers (USACE)
- **Navy and Marine Corps:** Naval Facilities Engineering Systems Command (NAVFAC), HQ NAVFAC Utilities, Washington Navy Yard
- **Air Force and Space Force:** Air Force Civil Engineer Center (AFCEC), Operations Director, Tyndall AFB

1-6 GENERAL BUILDING REQUIREMENTS.

Comply with UFC 1-200-01, *DoD Building Code*. UFC 1-200-01 provides applicability of model building codes and government unique criteria for typical design disciplines and building systems, as well as for accessibility, antiterrorism, security, high performance and sustainability requirements, and safety. Use this UFC in addition to UFC 1-200-01 and the UFCs and government criteria referenced therein.

1-7 ENERGY RESILIENCE.

All energy systems must be planned, designed, acquired, constructed, and maintained in accordance with Title 10, U.S.C., Section 2911(a), DoD Instruction 4170.11, and as required by individual Service and Defense Agency policies on energy resilience.

Resilience is the ability to anticipate, prepare for, and adapt to changing conditions and withstand, respond and recover rapidly from high-impact, low-probability disruptions \1\ /1/ impacting mission readiness per DoDD 4715.21. It is determined by the ability of a system to anticipate, resist, absorb, respond, adapt, and recover from disturbances such as natural disasters, terrorism, cyber-attack, or other significant and adverse impacts.

1-8 OWNERSHIP AND SUSTAINMENT.

To determine if a microgrid is a viable and sustainable solution, mission and public works personnel should review the installation master plan, energy plan, existing resilience posture, and commercial utility historical service performance including System Average Interruption Duration Index (SAIDI) and System Average Interruption Frequency Index (SAIFI) metrics per IEEE 1366 (an example of these metrics is given in Table D-1). Microgrids should be evaluated against alternative resilience enhancement solutions that reduce reliance on external commercial systems, improve resilience score, operational based readiness, and minimize lifecycle sustainment cost. When evaluating resilience enhancement options, refer to official policy and guidance provided by the appropriate military service.

Since microgrids primarily address resilience and mission assurance metrics, mission and public works personnel need to be consulted to determine 1) if a microgrid is an appropriate approach to advance these metrics, 2) ownership of the microgrid, 3) and capacity to operate and sustain a dedicated microgrid system. Real property and cybersecurity ownership, appropriate accreditation authority, and cyber-sustainment strategy must be identified.

1-9 CYBERSECURITY.

\1\ Design and install networked control systems (including “stand-alone” systems) in accordance with UFC 4-010-06. /1/

1-10 TOPOLOGY.

Microgrids are generally classified with respect to their sources and architecture. All installation microgrids are composed of energy sources, loads, one or more points of common coupling (PCCs), electrical distribution, switchgear, and secure controls (Figure 1-1). Specific microgrid topology is based on a distributed or central-plant architecture. Distributed microgrid architectures are composed of geographically disparate distributed energy resources (DERs) networked across the distribution system using secure controls and communications. Alternatively, central plant-based microgrids include co-located, generally large DER (for example, reciprocating internal combustion engines) to deliver power to the load, but generally with greater reliance on the distribution system. Regardless of architecture, type of DER, or configuration, all interconnected DER assets are subject to anti-islanding, mandatory minimum voltage ride-through, and under/over-voltage trip time safety requirements per IEEE 1547.8 when the microgrid is connected to the external grid. Inverter-based DER may only

interconnect to the islanded microgrid once the inverter has detected that the distribution has been energized by dispatchable (firm) DER (as listed under the Predictable Electrical Output column in Table 1-1).

1-10.1 Distributed Systems.

Distributed systems network discrete sources located throughout the microgrid boundary. Sources can be a combination of existing sources such as facility-level DERs or new microgrid-dedicated DERs. Distributed control points, switchgear, fiber network infrastructure, and the human machine interface (HMI) are the backbone of a distributed control system. While more communications intensive, distributed generation solutions offer the advantage of leveraging existing capital asset investments at many installations. See service-specific informing references in APPENDIX I.

The building block of a distributed energy microgrid's functionality is the facility generator's switchgear, which is generally sited near facilities with emergency generators (Figure 1-3). The microgrid architecture incorporates dedicated paralleling switchgear, breaker protection, and updated device protection settings to allow facility-level DERs to parallel and energize an islanded distribution feeder.

Figure 1-3 Distributed Generation Architecture

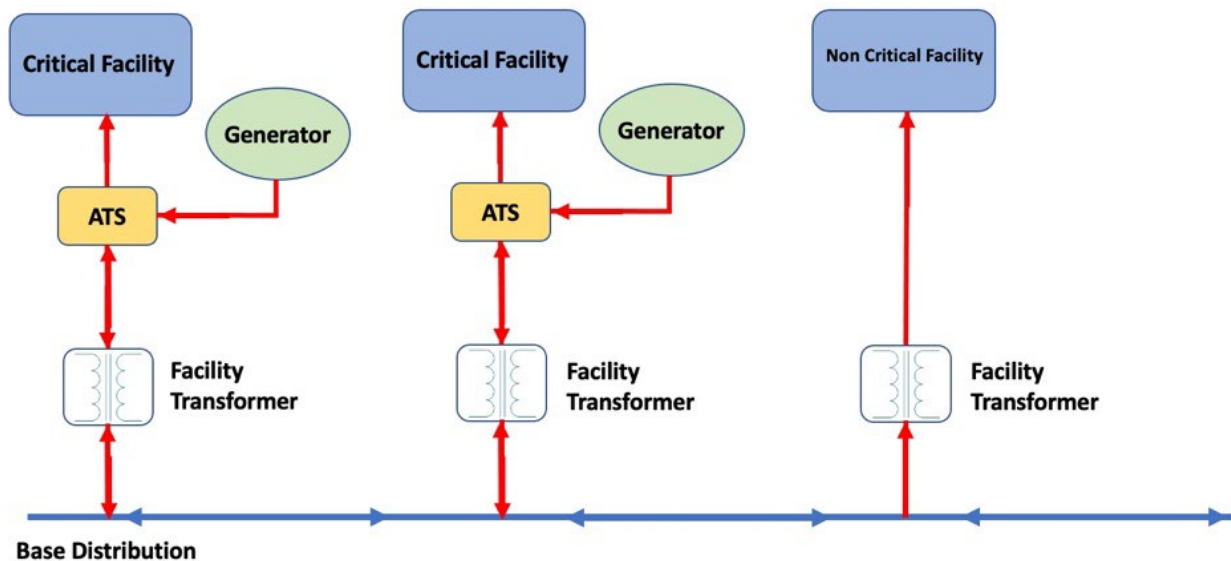
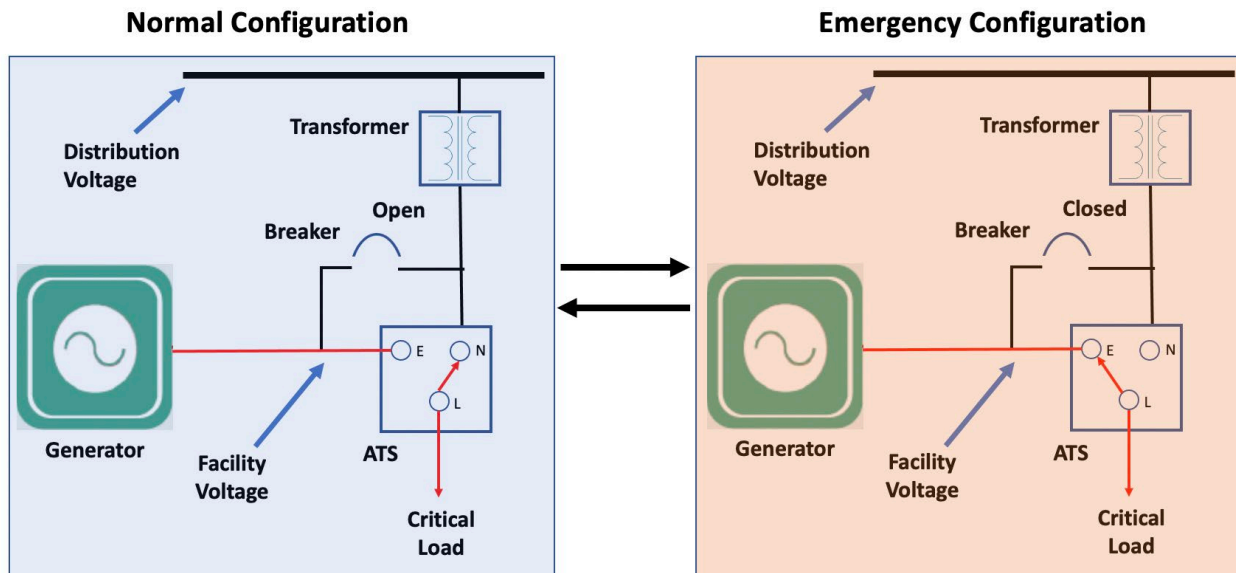

Figure 1-4 shows normal and emergency switchgear configurations across the ATS allowing increased functionality, beyond simply isolating a given facility and its generator from the distribution system. The emergency configuration is used to network each standby generator inside the microgrid boundary to a common bus using existing galvanic isolating devices. The bus is energized by the distributed generator fleet (much like discrete power plants supporting a utility's commercial transmission system, albeit at smaller scale).

Figure 1-4 Normal and Emergency Switchgear Configuration Across ATS



As soon as external grid power is lost, facility-level DERs come online. Many of these facility-level DERs are standard emergency generators associated with specific loads.

The DERs operate autonomously per UFC 3-501-01 (Electrical Engineering) and UFC 3-550-01 (Exterior Electrical Power Distribution), and tend to be out of phase with each other. When the interconnection point is opened and the installation is disconnected from the external grid, the DERs must first synchronize before forming a microgrid. DERs must operate “in phase” as they are connected (this is also true of the renewable resources that are subsequently networked to the microgrid). A reference frequency is selected from the DERs and the remaining DERs synchronize to this reference. The synchronization process repeats when the external grid is restored and the microgrid prepares to reconnect at the PCC. In this case, however, the microgrid DERs (in unison) use the external grid frequency as the reference when synchronizing to the utility.

An important benefit to this approach is that it leverages DoD’s existing fleet of fuel-based generation. Infrastructure already specified in current design guidance can be applied to support a distributed microgrid, with paralleling switchgear and modification in engine governor controls. Since many facility-level DERs require dedicated paralleling gear and updated protection settings, it is advisable and prudent to network larger DERs with significant remaining service life and appropriate generator and emissions certification (for example, larger than 250kW, prime/continuous rated Tier 4).

1-10.2 Central Plant Systems.

Central-plant based systems employ a central generating plant, often including RICE units, combined heat and power, co-generation, or other configurations, with co-located DER (e.g., turbines, reciprocating engine, gas-fired, fuel-fired, or fuel oil-fired generators). While generally more dependent on distribution system, these solutions

are typically more efficient when backing up large base loads. Additionally, central plant systems can typically tolerate greater contributions and variability of renewable energy generation without energy storage.

1-10.3 Fuel-Based, Dispatchable (Firm) Generation.

These are assets that deliver “firm” dispatchable power and include turbines, diesel, propane, or natural gas generators. Fuel and gas-based generation (including facility-dedicated standby systems) are dispatchable. These systems are typically capable of black start, grid-forming operation, and load following.

These systems are frequently sited on DoD installations with automatic transfer or automatic distribution switches (to support dedicated standby operation following loss of service) and are capable of operation without an energized distribution system or microgrid signal. These assets are generally capable of black start operation (when the distribution bus is not energized) and can be networked within an islanded distribution grid (sometimes requiring engine governor modification). These DERs can be sized for standby, prime, or continuous application (emergency operation, unlimited hours at variable load, or unlimited hours at a constant load, respectively).

1-10.4 Inverter-Based Generation.

Contributions from inverter-based and renewable DERs may defer fuel resources and extend off-grid operational endurance in an extended emergency. The electrical output of these DERs is delivered in direct current (DC), requiring one or more inverters to interface with installation distribution. Because these systems rely on differing inverters at their output, their degree of visibility, controllability, and flexibility to support the microgrid design intent can vary significantly. Inverter based generation is subject to UL 1741 per UFC 3-540-08. Additional tolerance (capacity) factors should be included when generation is intermittent or non-dispatchable.

Higher interconnection of inverter-based assets on small microgrids can often necessitate increased firm, dispatchable generation with reserve capacity to manage source intermittency, islanded load variability, non-linear loads, inductive and motor start loads, and other high-VAR load requirements.

1-11 ENERGY RESOURCE CLASSIFICATION GUIDE.

Table 1-1 provides DER attributes and common applications to inform design. For clarity, the table column categories are explained below:

- Primary power: the primary energy resource, used to reliably meet largest portion of load – can be replaced with utility
- Base load power: the ability to provide base load power is highly variable, depending on the size of loads served
- Load following: the DER follows the load and can adjust power output to amount of power needed

- Power quality correcting: also referred to as improve power quality
- Inverter based system: systems may include inverters that convert power from DC to AC
- Predictable electrical output: may also be referred to as firm or availability of power when needed
- Grid forming DER now includes all DERs listed under Predictable Electrical Output column of Table 1-1

1-12 PROGRAMMING.

Primary Category Codes for microgrid resilience and backup power projects include 81109, 81110, 81160, etc. Revisions to this UFC will include additional category codes for networked standby power projects.

1-13 GLOSSARY.

APPENDIX G contains acronyms, abbreviations, and terms.

1-14 REFERENCES.

APPENDIX H contains a list of references used in this document. The publication date of the code or standard is not included in this document. Unless otherwise specified, the most recent edition of the referenced publication applies.

Table 1-1 DER Attributes

	\1\ /1/ Predictable Electrical Output	Inverter Based System	Standby Power	Black Start (Dispatcha ble)	Primary Power	Base Load Power	Load Following	Power Quality Correcting
Turbine or Engine- Driven (Low Speed)								
Engine- Driven and RICE (High Speed)								
Facility Level, Stand- alone Engine- drive					⁵			
(Natural) Gas-Fired							⁴	
\1\ Small Modular Reactors (SMR) /1/								
PV			¹	¹	¹	¹		
Wind Turbine			²		²	²		
Fuel Cell (High Temp)				³	⁷			

Fuel Cell (Low Temp)								
BESS/UPS								
Flywheel (FESS)								
Symbol Key	✓ = Yes, ideal ▲ = Possible, with caution ⓧ = No							
Caution Notes December 28, 2022	¹ subject to availability allowed by weather conditions ² subject to wind conditions; min speed must be met & max (lockout) speed not exceeded ³ battery storage must be charged ⁴ only for microturbines ⁵ facility-level dedicated generators are typically permitted for backup only. \1\ See UFC 3-540-01. /1/ ⁶ instant backup power – rapid ride-through ⁷ energy storage must first be charged by another resource, but can still serve significant loads							

CHAPTER 2 TECHNICAL REQUIREMENTS

2-1 MINIMUM DESIGN REQUIREMENTS.

To be in compliance with the criteria prescribed herein, the design must:

- a. Be capable of islanding with ability to network (or parallel) more than one independent source of generation
- b. Be a Bounded System with autonomous generation, distribution, controls, and Human-Machine Interface (HMI)
- c. Include Black Start¹ Capability: Be capable of grid-independent black start with a minimum of one grid-forming DER²
- d. Contain sufficient generating sources, stored form of energy, and reserve capacity³ to meet the peak critical load within the system boundary with off-grid endurance not less than the duration of time required by mission and service policy
- e. Include System Balancing: Contain Grid-Independent ability to energize critical loads and optimize load factor
- f. Include fail-safe ability that resorts to load-dedicated (or pre-microgrid) operation following electrical system, communication, or other network disruption
- g. Have risk management framework process initiated. This may include a Cybersecurity Authorization to Operate (ATO) by a DoD Approving Official (AO)
- h. Use technology that is commercial, warranted, and supports permanent infrastructure improvement. This UFC is not intended to govern research, development, demonstration, emerging practice, or developmental technology.

The following considerations represent recommended best practice and should be included as scope and funding of a project allows:

- Redundant networked sources of generation
- Energy storage
- Bi-directional soft, “blinkless” transition

¹ Black start is starting a microgrid system after unplanned grid failure with no energized generation resources.

² Energy Resilience Readiness Exercise (ERRE) tests the operational capabilities of microgrids to support mission operations in the absence of normal utility power.

³ Reserve capacity is the uncommitted, immediately-available generation capacity on the network, accounting for islanded load variability, non-linear loads, motor start, and other high-VAR, inductive, and nonlinear load requirements.

- Grid connected support, with capability for demand response, and ancillary services such as frequency support, voltage management, and black start
- Redundant (min 2) grid forming assets
- Redundant (min 2) HMI Visualization HMI Front-Ends
- Redundant (min 2) Independent Black Start Sources
- Load Shedding Capability
- Be capable of re-synchronization and soft (seamless) transition back to the external grid

2-2 PERFORMANCE REQUIREMENTS.

Agency policy, mission needs, and installation requirements should inform the performance requirement, which then informs the basis of design and, subsequently, the acquisition. All installation microgrids must include the following elements: energy sources, loads, one or more PCCs, electrical distribution and switchgear, and secure controls. The following requirements listed in paragraphs 2-2.1 to 2-2.4 are also mandatory.

2-2.1 Autonomous Operation.

A microgrid must be capable of providing power independently of all external power and communication networks. In this respect, microgrids are autonomous. However, the degree to which a microgrid is configured to automatically enter into its active states of operation following an outage must be carefully considered based on mission Continuity of Operations (CONOPS) and personnel requirements. Degree of automation can vary from having a required “human in the loop” input command between each system configuration and operational state, to fully automated systems that are “Always Sensing” systems with no required user intervention between each system state.

2-2.2 Safety and Grounding.

Because the systems often integrate generation on the load side of facility transformers and operate independently from the external grid, designs may require dedicated or modified grounding during certain conditions of operation. Special design consideration must be given to islanded operational states requiring dedicated grounding and protection configurations per AFMAN 32-1065. Prior to integrating microgrids into existing installation systems, evaluate if:

- existing installation distribution equipment and switchgear are integrated;
- dedicated or modified grounding during certain conditions of operation are required;
- any islanded operational states require dedicated grounding or updated protections at any location.

2-2.2.1 Safety and Arc Flash.

Designs often include system simulation or modeling to update arc flash and safety protections and identify issues with equipment duty ratings that require upgrading or replacing existing equipment, or increases in arc flash that require mitigation and protective device coordination. Any analysis developed or updated must be performed in the prevailing modeling environment used by public works and the local utility. The model must be updated per NFPA 70E by a qualified engineer. All updated model files should remain the property of the government.

2-2.2.2 System Grounding.

Grounding needs specific attention when the microgrid is designed. Grounding configuration must be assessed during all conditions of the microgrid, including all operational modes and all temporary modes that may conceivably exist during microgrid formation and disconnect. Grounding systems are required although equipment may be disconnected from the main power but remain live at different points. Careful analysis, including modeling, is required for both the grid connected and islanded modes (and all configurations between) to protect equipment and personnel during fault conditions.

2-2.2.3 Fault Protection.

Specific attention must be given to islanded fault protection. When connected to the utility grid, the distribution system is capable of delivering the necessary short circuit system performance based on protective relay settings at substations. When the distribution is energized in islanded mode, system inrush current may cause deviation in islanded voltage and frequency triggering generator under speed protection or other DER protections. Short-circuit characteristics of the networked sources may not consistently produce sufficient current to be detected using existing protection settings; allowing faults to be undetected and potentially cause system damage. Consequently, the grid-connected protection configuration (before a microgrid is implemented) may not offer adequate fault protection. The design must include updated protection settings at system and device level to isolate or clear faults to prevent damage to equipment and loads. Analysis of the system protection architecture includes system simulation or modeling prior to final design approval. In some cases, protective device coordination studies are performed as part of design and updated during construction. Refer to APPENDIX E for additional performance metric and safety information.

2-2.3 Cybersecurity and Risk Management Framework.

Designers must refer to UFC 4-010-06 for all microgrid designs as the primary resource for planning cybersecurity protocols in advance of acquisition. Within DoD, each agency has an AO who determines the “Authority To Operate (ATO)” based on risk, and approves the final implementation (representing minimized, well-managed risk). Based on the organizational mission and details of the control system, the System Owner and AO determine impact levels (LOW, MODERATE, or HIGH) for the control system. The Designer of Record must coordinate with the relevant service-specific authorities and

ensure that the DoD approved evaluation processes and risk management framework for cyber security concerns are addressed.

When Applying Risk Management Framework to Microgrid Controls Systems, the network boundary should include all control points and IP-addressable assets constructed as part of, or controlled by, the microgrid system. Facility control systems are not information technology (IT) systems; they should not use standard IT system approaches and not be connected to public systems, especially internet systems, and not have remote access. (no access outside of defined and approved system architecture network boundary).

2-2.4 Utility Management Control System (UMCS) Integration.

System design must demonstrate minimum interoperability with existing (or planned) UMCS, specifically any data required from UMCS as part of microgrid operation or information from microgrid system to UMCS for display or other purposes. Interoperability may support aspects of microgrid design including communication with, or control of, primary assets of the Utility Control Systems (UCS) as described in UFC 3-470-01.

CHAPTER 3 PERFORMANCE METRICS

Consistent with OSD Metrics and Standards for Energy Resilience at Military Installations (2021), the microgrid performance-based design process must identify performance metrics and goals to inform the basis of design. This includes the following metrics described in this chapter.

3-1 OFF-GRID SYSTEM ENDURANCE.

Off-grid endurance is a primary performance metric that must be used to inform system design and must be identified in the basis of design. This refers to the total duration the microgrid can carry the peak critical load without the return of commercial power or refueling service (i.e. islanding duration). Regardless of what level of off-grid endurance is targeted, the final design must provide a total amount of onsite stored form of energy (fuel, gas, compressed gas, electrical energy, etc.) that meets the target. \1\ The AHJ may approve reliance on confirmed delivery sources for off-grid endurance with written consent of the Component Technical Representative. /1/

This target metric must be informed by prevailing DoD service policy and mission assurance requirements. Traditional standby generation design practices have targeted 72 hours of system endurance for all critical loads served by the network. \1\ /1/ OSD Metrics and Standards for Energy Resilience at Military Installations promotes a 14 day target for mission loads. DoDD 3020.26 includes language to ensure performance of Mission Essential Functions during any emergency for a period of up to 30 days or "until normal operation can be resumed".

3-2 PEAK CRITICAL LOAD SERVED.

The design must have the capacity to support the peak load demand of critical systems when they are engaged in normal and peak mission activity (along with any non-critical loads that are incidental or non-segregable). Analysis of mission load profile during times of normal and peak mission activity must be conducted to verify adequate generation as well as load following capacity is available.

The load analysis must give specific consideration to step loads, highly nonlinear loads, motor and high-VAR inductive loads, as well as projected and actual or tested requirements in island mode. Load analysis must be conducted for both grid-connected and island modes.

3-3 LOAD SHEDDING.

Load shedding is the capacity of the design to shed load to maximize endurance of higher priority mission operations. The engineering analysis must include options for active load management and load shedding maximize off-grid endurance of mission loads. The load shedding plan must consider mission dependency criteria and installation load restoration plan to support the level of energy resilience required for the microgrid's essential facilities (see Table 4-2). Load shedding can be implemented by sequential restoration at substation breakers or via under frequency load shedding. For

cases with nominal non-critical loads (or that are not easily segregable), designers must assess the tradeoff between incorporating additional load-shedding switchgear against the marginal cost of additional generation and system capacity required to support those loads.

3-4 RESTORATION TIME AND SOFT TRANSITION.

The microgrid system is responsible for transitioning to islanded power following a commercial power outage, as well as transition back to external power following commercial system restoration. Restoration time to supply power to all critical loads in the network is an important performance factor. This includes the time required for the system to island at all points of interconnection, parallel and synchronize generation, and deliver power to the designated critical load(s) in accordance with mission and installation circuit priority. This can range from soft transitions with instant “blinkless” power to the critical loads, to seconds or minutes (see Figure 4-3).

While not an explicit criteria requirement, designers must consider any specific operational needs or loads that may require soft transition both to and from islanded operation.

3-5 OPTIMIZED DER LOAD FACTOR.

Optimize DER load factor to the extent to which the design minimizes low load factor operation of individual DER assets including operation of assets in a reserve capacity. This includes minimized operation of fuel-based generation operating at low load factor, load banks, and other operational inefficiencies. Optimizing target DER load factor improves off-grid endurance and economizes system operation by preferring lowest-cost form of generation, renewable generation assets, and energy storage. Designers must assess the tradeoff between larger DERs (associated with more attractive capital and operational cost per unit output) against smaller DERs (as a network, can support system requirement at higher load factor).

3-6 ENERGY SURETY AND REDUNDANCY.

Redundancy is the allowance for failure or loss of at least one significant generation network DER and still serve the peak critical load requirement.¹ The aggregate generation capacity of the network must meet or exceed the maximum peak critical load based on the load analysis. The degree of required redundancy in the network must correspond with the resilience requirement of the load. See load designations in Figure 4-3.

3-7 DEGREE OF RENEWABLE ENERGY CONTRIBUTION.

¹ This degree of redundancy may not be viable for large-scale projects, peaking plants, or designs primarily targeting grid support (often comprising very large DER systems).

Systems exclusively using renewable generation sources must verify sufficient available storage and black start performance to manage islanded resilience requirements.

3-8 OPERATIONAL VISIBILITY AND GRAPHICAL INTERFACE.

Designers must include the graphical human-machine interface (HMI) that conspicuously illustrates system state, operational parameters and condition of major components, available reserve fuel and other forms of stored energy, position of major switchgear components, and flow of power within the system boundary. The HMI should be intuitive and interactive for system operators. Interface elements shall conform to accepted power system industry standards per IEEE 1826. The HMI must include dedicated uninterruptible power supply (UPS) of no less than 2 hours to accommodate operation during changes in operational state.

3-9 EXPANDABILITY AND RECONFIGURABILITY.

System design needs to accommodate load growth or mission expansion with minimal design reconfiguration, reprogramming, and recurring engineering costs. Scalable designs can accommodate mission growth by expanding the number of network sources, the size and location of the addressable load, and reconfigure/reprioritize load without significant re-design, retrofit or replacement of capital assets (distribution switchgear, motor controllers, substation equipment, etc.). All design modification and expansion must accommodate and adhere to installation configuration management protocols. Designs with looped distribution, multi-terminal switches, and bypass of DERs and switchgear (to minimize impact of equipment maintenance and testing) should also be considered. A MILCON is valid for five years; expansion after that five-year period requires a new MILCON. Should a new project require modification or expansion of the microgrid, then that activity must fund all required upgrade to the system, including any additional generation, to maintain operational functionality. Perform studies to determine if a microgrid is appropriate. For bases with existing microgrids, study to determine if new construction requires a new microgrid or if it can be integrated to an existing microgrid as an expansion.

3-10 GRID-CONNECTED AND ECONOMIC APPLICATIONS.

The degree to which the design allows for grid-connected operation or applications supporting economic incentives including demand response, load curtailment, grid-support services, or other ancillary arrangements that improve lifecycle payback. The lifecycle value of these design attributes is a function of site location, degree to which the region is energy constrained, nature of existing power purchase agreements, and commercial utility needs.

3-11 POWER QUALITY.

Power quality is a significant consideration for islanded microgrids. Because microgrids energize smaller systems than commercial grids (and generally operate with less reserve generation capacity), loads can be impacted by ramping effects from large renewable systems, power system transients, and other power quality events. Transients resulting from normal operations such as switching, renewable energy variability, and transformer inrush currents must be managed to avoid equipment damage. The design must accommodate large motor starting and other nonlinear and reactive power events during islanded operation. Grid modeling and short-circuit analysis is generally required at sites with: low short-circuit ratio, substantial dynamic power system considerations, other power quality challenges, or where required by the commercial utility operator. Microgrid systems are now capable of following the load and provide power to the systems needed.

CHAPTER 4 PLANNING, DESIGN AND ACQUISITION

4-1 MICROGRID PERFORMANCE-BASED PLANNING AND DESIGN.

Planning and design must be informed by performance criteria. Performance-based acquisition uses performance criteria, rather than prescriptive criteria, to inform planning, design, and acquisition (for example, total amount and duration of load to be supported rather than prescribing the number and size of DERs, switches.) Such a performance-informed approach allows the DoD to assure salient service policy and installation requirements are fully reflected in the project from inception, without being unnecessarily prescriptive as to the type or form of generation solutions, size, or controls in advance of acquisition.

For USAF projects, AFMAN 32-1062 specifies USAF approval process of generators for prime power, cogeneration, or microgrid applications. Air Force Civil Engineer Center/Operating Directorate (AFCEC/CO) must coordinate on all government funded microgrids, and AFCEC Energy Directorate (AFCEC/CN) must coordinate on all third party funded microgrids. Commissioning should include all items needed on hand for O&M/Repair such as spares/repair parts/supplies/special tools/special test equipment. Develop a configuration management plan and implementation of procedures for controlling changes to the design baseline over time.

4-1.1 Performance-Based Planning and Design Process.

The planning and design process includes identifying and applying salient organizational policies, including application of DoD energy resilience policy and directives (e.g., DoDI 4170.11) as defined by 10 USC 2911, climate goals, and UFGS/UFC criteria early in the concept development. Refer to Figure 4-1 for the microgrid design progression. Planning includes:

- Defining objectives
- Defining scope
- Assessment of options
- Condition assessment
- Other operational requirements

All design activities must consult the Public Works/Public Works Officer (PW/PWO) office and utility operations to ensure all equipment selection, specification, documentation requirements, HMIs, software configuration, sequence of operations, operational visibility, and other elements aligns with mission and installation operation and protocol.

Figure 4-1 The Microgrid Design Progression

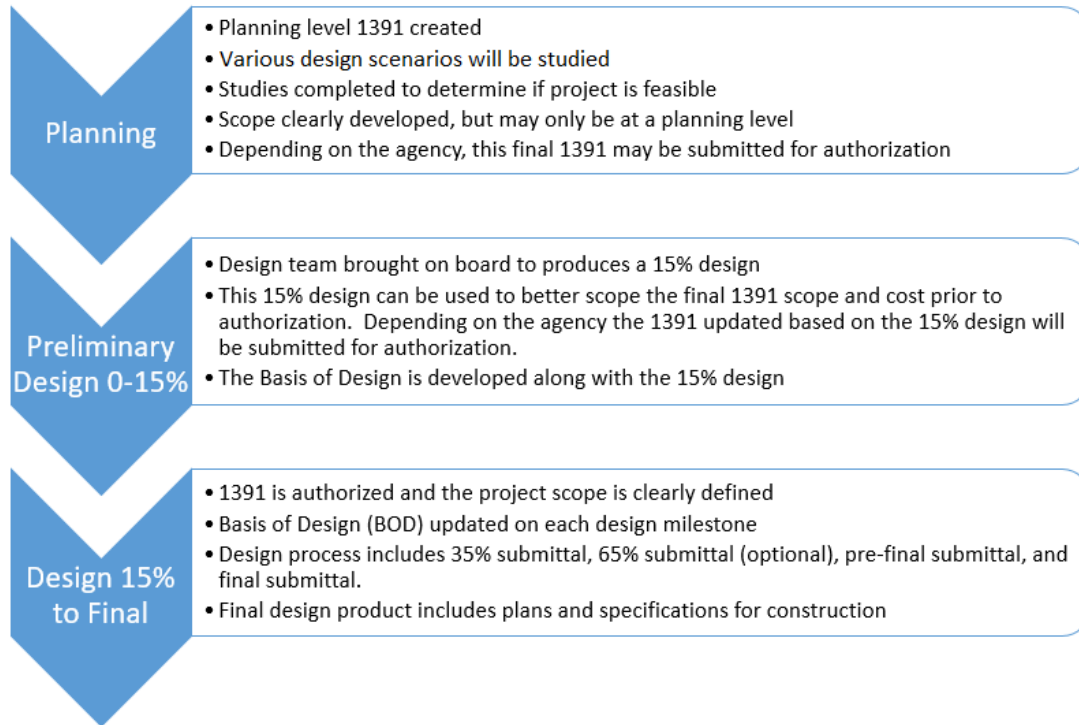

4-1.2 Checklist for Compiling a Planning DD1391.

DoD uses DD Form 1391 to support funding requests for military construction projects to Congress. The form is used to record the installation's program in relation to personnel strengths, real property improvements, mission and functions. A sample DD1391 is provided in paragraph D-2.1. Reference annual planning guidance for the Energy Resilience and Conservation Investment Program (ERCIP) issued by Office of the Secretary of Defense (OSD) for the latest DD-1391 format and required information with respect to ERCIP submissions. ERCIP submissions from all components are evaluated annually for funding and need to contain required information in prescribed format.

4-1.3 Methods of Procurement.

Microgrid systems can be acquired either directly through installation resilience resources such as DoD MILCON, ERCIP, and Intergovernmental Service Agreement (IGSA), or under alternative third-party financed arrangements such options include Energy Savings Performance Contracts (ESPC), Power Purchase Agreements (PPAs), Utility Energy Service Contract (UESC), Utility Privatization (UP), or as part of in-kind consideration with a public utility or independent power provider for leased military sites. Resources required to support system O&M and testing throughout the system lifecycle

should be identified and microgrid performance should be recorded as required by each Service.

4-1.4 Construction Sequencing.

The designer must include sequence of construction. Schedule coordination with ongoing operations is critical, particularly for cut-in/tie-in work and equipment upgrade and swap out. Construction activities can be coordinated with normal maintenance shutdowns and affected component Commands for acceptable outage times.

Additionally, the sequence of construction needs to be considered. For example, if a high-penetration level of PV renewable energy is to be installed with a battery energy storage system (BESS), it is best to install the BESS first, to manage power stability prior to installing of the PV system.

4-2 PLANNING AND MODELING (0-10%).

Planning and modeling determines feasibility and viability of a networked standby power solution. Mission needs and lifecycle costs (capital and operational) are considered. Options for a combination of energy sources, to include renewable energy and energy storage options must be investigated at the start of any microgrid project (often referred to as techno-economic analysis). Mission requirement, service policy, and prevailing DoD guidance must inform the early design.

The planning phase must also identify existing power system models (for example, Easypower, ETAP, SKM, and PSCAD) and include scope to reflect all changes and impacts from the microgrid project.

The conceptual design should include the following elements. Refer to Sections 4-2.1.1-4-2.1.11 for further details on each element.

- Defining system boundary (based on stakeholders and mission commands with elevated security requirements)
- Identification of critical loads to support with microgrid
- Identification of mission owners, system owner, and cybersecurity accreditation authority (UFC 4-010-06 is the primary resource for planning cybersecurity)
- Identification of areas requiring electrical system modeling or updating
- Feasibility and constructability of alternatives
- Utility interconnection application and studies
- Compiling draft layout and list of systems components
- Complete cost estimation and cost-benefit analysis

4-2.1 Conceptual Design Elements.

4-2.1.1 Defining System Boundary.

The system boundary must be defined based on mission need, infrastructure configuration, and operational requirement (see Figure 4-2). A system boundary is determined based on mission requirements, existing power generation and distribution infrastructure, ease of electrical isolation (based on the one-line diagram), deficiencies in resilience related to the electrical supply to loads, and optimization of new and existing and DER sources, power distribution, and supporting fuel supply.

Figure 4-2 Microgrid Boundary

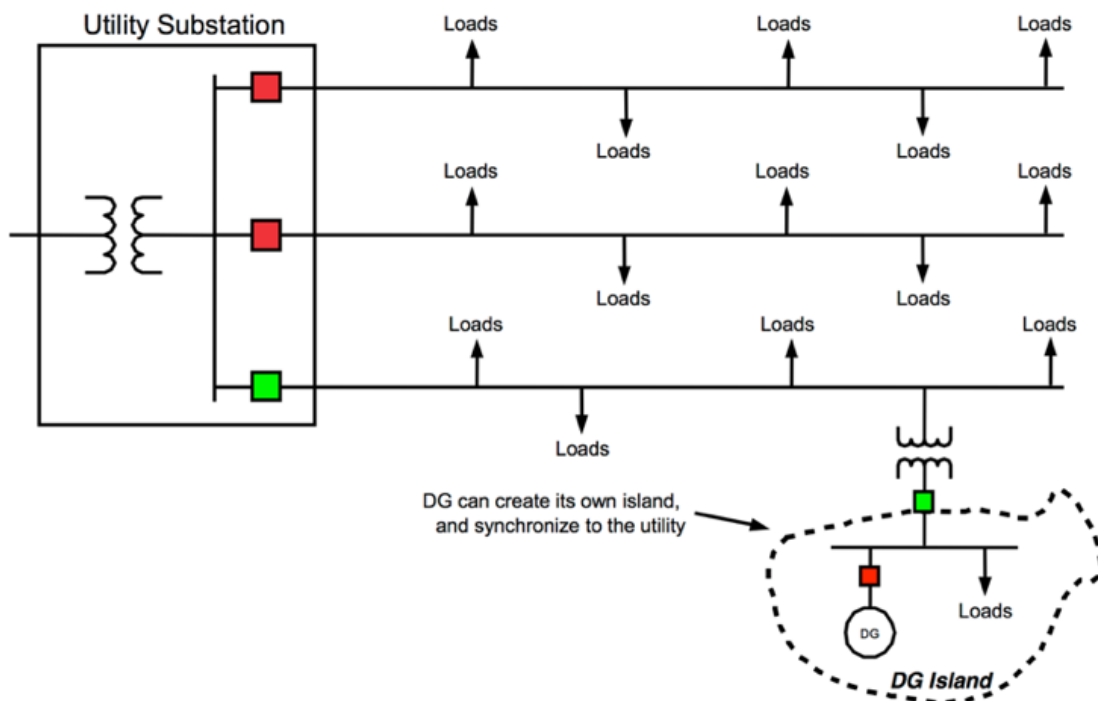

4-2.1.2 Identifying Critical Loads.

During the conceptual design phase, critical loads need to be identified. Designers must consult with the affected mission owners to define requirements, associated dependencies, and critical loads that, if lost, will ultimately lead to a failure of an identified mission-critical system. A notional example of load designations based on allowable annual outage duration is shown in Figure 4-3.

Figure 4-3 Load Class Designations and Annual Down Time

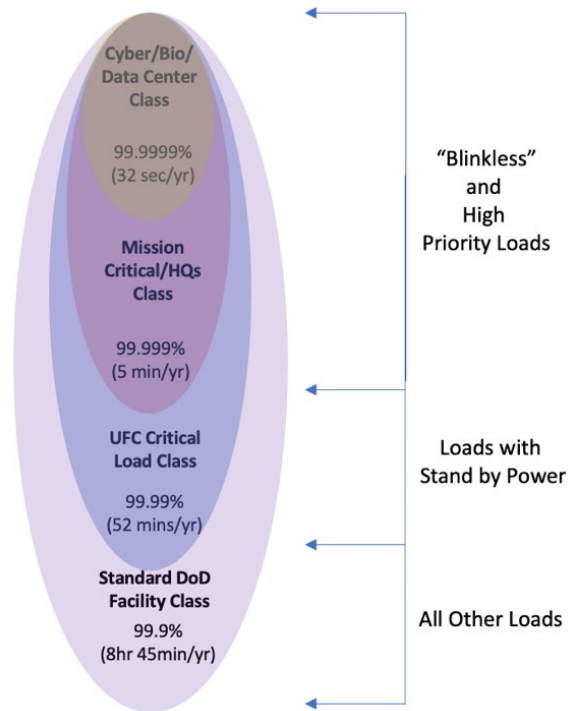

Identification and prioritizing of critical loads is informed by the mission. Buildings, systems, and other critical elements required to support the mission elements must be identified. The following are characteristics of microgrid critical assets and systems:

- Time Basis: Loads should be identified as to how long after power outage they are needed (uninterruptible, seconds, minutes, hours, days, and weeks). Also, how long must load be supplied each day?
- Load Requirements: Full load, peak load, average load, or minimum load need to be subdivided into critical and non-critical loads. Can control systems be used to drop non-critical loads?

During the iterative stakeholder process, the designers must tailor microgrid performance to meet mission requirements according to each of the performance metrics in CHAPTER 3.

Certain critical loads may already have load-specific generation that cannot be interconnected to the microgrid for technical or mission reasons. Under these conditions, designers can proceed with a system designed to relieve mission-dedicated generation without controlling or interconnecting load-dedicated generator(s). Under this scenario, the local facility's Automatic Transfer Switch (ATS) system identifies energized distribution (due to normal grid or microgrid operation) and refrains from switching to emergency position. In this way, the local facility generator serves as an

additional level of redundancy for that facility above and beyond what is delivered by the microgrid (see Figure 1-2).

4-2.1.3 Power System Modeling and Microgrid Design Modeling.

DoD is required to use analytical tools when evaluating energy resilience measures, such as microgrids, that are accurate and effective in projecting the costs and performance of such measures (10 U.S.C. 2911). Two types of models are used to inform microgrid planning: Microgrid Design Modeling and Power System Modeling. Refer to Table 4-1. APPENDIX B provides an assessment of available microgrid design tools relative to these requirements to aid designers in picking the best tool for the installation. As microgrid design tools continue to evolve, APPENDIX B will be updated.

Microgrid design modeling is instrumental to inform planning. This modeling employs microgrid design tools (see Table 4-1) to produce a techno-economic analysis of optimal DER type and size based on energy resource costs, impacts of interdependent design decisions, attractive economic or lifecycle solutions, and other performance factors necessary to interpret the design space and evaluate the tradeoff of alternatives. Microgrid design tools account for mission requirements and distributed energy resources' performance to facilitate defining conceptual designs. It allows installations to understand the design space and evaluate the cost and performance of alternatives.

Power system modeling determines grid maximum short circuit available and performance of the power system by calculating short-circuit analysis. Small, isolated grids with higher penetration of power-electronic-based DER typically operate at lower short-circuit ratio (SCR) performance. A grid's SCR performance is bounded by the theoretical conditions of 1) an infinitely stiff bus behaving as an ideal voltage source with zero impedance, such that any attempt to change the voltage produces an infinite supply of current, maintaining a constant voltage, or 2) a weak bus where it is easy to change the voltage by sourcing small amounts of current.

Table 4-1 Microgrid Modeling Tools Vs Power System Analysis Tools

	Microgrid Modeling Tools	Power System Analysis Tools
Focus Area	Technology Tradeoff and Economic Analysis of DER	Power System Stability and Operation Performance
Components Sized or Designed	Turbine-Drive DER, Engine or Gas-Driven DER, Renewable DER, Storage-Based DER, etc.	Protective Device Selection, Time-current curves, Relays, and ArcFlash Reduction Maintenance Settings, etc.
Output	Techno-economic Alternatives of Microgrid Concepts and Lifecycle Costs	Short Circuit, Arc-Flash, load-flow, or Grid stability analysis
Supports	Planning (0-10%)	Modeling and Detailed Design (10-100%)
Notable Examples	Listed in APPENDIX B	SKM, Easy Power, ETAP and PSCAD.

4-2.1.4 Constructability, Feasibility, and Site Constraints.

Microgrid implementation will consist of installing controls, adding switches, realigning supported loads to high priority feeders, and changing operational procedures. Planned modifications and infrastructure improvements to the distribution system must be integrated and leveraged during conceptual design. Designers must specify candidate load centers and design options, and provide alternative options (for example, centralized or distributed generation solutions) to support maximum critical load given current operational conditions, practices, and CONOPS.

The following site constraints or restrictions raise unique issues for microgrid design projects and careful consideration must be taken:

- Footprint and environmental permitting issues associated with one or more microgrid DERS and energy-storage locations. Often it is attractive to centralize any new generating capacity near substations and to use larger generators because cost per unit capacity is lower.
- Site space, permit, and climate factors associated with renewable energy: this includes site operational issues, such as mission conflicts with wind turbine operation. Planners must reference the prevailing design guidance for facility-scale renewable assets (UFC 3-440-01) and utility-scale renewable assets (UFC 3-540-08).
- Building code issues
- Restrictions on commercial power procurement agreement with local electric utility and options available to modify the service contract: includes options available to cost share (capital cost or maintenance cost)

- Other challenges aligning infrastructure with microgrid operation
- Fire protection offsets, especially for further addition of battery storage (UFC 3-600-01)

4-2.1.5 Facility Classification.

Prioritization of facility loads must be informed by their mission profile, installation’s emergency response plan, installation energy and water plan, and established/identified deficiencies (interrelationships and dependencies of those loads must be confirmed). See Table 4-2. Additional documents to be reviewed include the Critical Infrastructure Program, Mission Assurance Program, and Mission Dependency Index.

Table 4-2 Facility Designation in Microgrid System

Facility Designation	Microgrid Supported Conditions	Examples
Microgrid Essential Facilities	Supported under all modes of operation	Facilities meeting criteria of UFC 3-540-01, or with other significant mission-dependence
Microgrid Supported Facilities	Served by microgrid under most conditions, can be shed during extended grid events	Facilities meeting criteria of UFC 3-540-01, or with other significant mission-dependence (HQ, command and control, data or communication centers)
Microgrid Discretionary Facilities	Can be served by microgrid, located within system boundary	Discretionary facilities not consistently requiring secure power for the entirety of an outage event
Non-Microgrid Facilities	Are not located within system boundary	Facilities that do not have an elevated stand-by power requirement

4-2.1.6 Load Analysis & AMI Data.

The microgrid must support the peak-load demand of mission critical systems. A load analysis is necessary to size system components and develop an informed load shedding capability schedule. Essential loads to be served by the microgrid and optional loads, as defined by facility categories in Table 4-2, must be identified during the engineering analysis.

The highest resolution energy consumption data must be used and must include load variation due to season, mission operational tempo, and other major impacts to load profile. For many sites, high-fidelity load data is stored in digital relay devices, or is reported via Smartgrid or UMCS enterprise systems. At other locations, AMI meter data is most accessible. Realistic estimates of real-world data, with reasoning provided will inform the design and critical engineering decisions. If AMI data is available, the difference between total base load and AMI metered load can be used to estimate and

create a load curve for the remaining loads. Additional techniques that may be used to determine this include the following:

- Refine estimates by studying the available load curves based on season, time of day, day of the week, holiday, workload, outside temperature, and operating information and discuss the requirements with building and system owners (AMI, with gaps estimated.)
- For certain building types, such as office buildings, typical load information for the building design and use may be available.
- For some large, non-critical loads, it may be possible to make a rough estimate by dropping the load and seeing how much the closest upstream meter moves.
- For critical loads with existing emergency generators, the generator output during past utility outages is a good indicator of load that must be supported by the new microgrid.
- \1\ Temporary metering for a period of 30 days or more performed during peak demand periods, i.e., high operational tempo and maximum heating or cooling periods. /1/

4-2.1.6.1 Peak Loads.

The microgrid must support the peak-load demand of critical systems when they are engaged in normal mission activity. The engineering analysis must include options for managing loads, including loads in critical buildings that are not mission critical. Simpler design and operations can often be realized by backing up an entire load center should a facility or load center contain non-segregable critical and non-critical loads.

4-2.1.6.2 Thermal and Non-Electrical Loads.

During analysis, the designers must give special consideration to thermal and other non-electrical requirements, including heating, cooling, industrial loads, mechanical loads, pollution-abatement systems, or other specialty functions. Startup requirements of these loads, associated in-rush or motor start needs, and other non-linear load requirements must be specifically addressed if such systems are to be supported by the microgrid during islanded operation.

Other areas to consider for thermal and non-electrical load analysis include:

- Magnitude of real (Watts) and reactive (Vars) power for each phase and total
- Apparent power in VAs for each phase and total
- Power factor for each phase and average
- Averages of energy in kWh and reactive

- Rated capacities of infrastructure
- Seasonal effects of temperature and usage
- Derating factors for equipment
- Theoretical additional load information

4-2.1.7 Integrating Storage-Based DER.

Integrating energy storage technology can enable many additional use cases for microgrids. Figure 4-4 provides performance attributes of different energy storage technologies. Electrical energy storage can be considered if the design must support any of the following performance requirements:

- Blinkless transition to or from external grid power
- Rapid load restoration, UPS-grade support
- Rapid load-following
- Facilitate very high percentages of renewable utilization
- Firming Renewable DER Output (for example, solar "smoothing")
- Minimizing unnecessary spinning reserve and fuel-based generation
- Active power quality support
- Supporting demand response, peak-shaving or other grid services

Should energy storage be deemed prudent, designers must define the applications, operational states, and scenarios the storage will support. This allows both appropriate type of storage (Figure 4-4), sizing of the storage system (and inverter), how the system should manage State of Charge (SOC), and rate of charge/discharge (greater discharge "C-rates" generally result in less cycle efficiency for electrochemical-based storage systems).

Figure 4-4 Specific Energy vs. Specific Power for Storage DER Assets

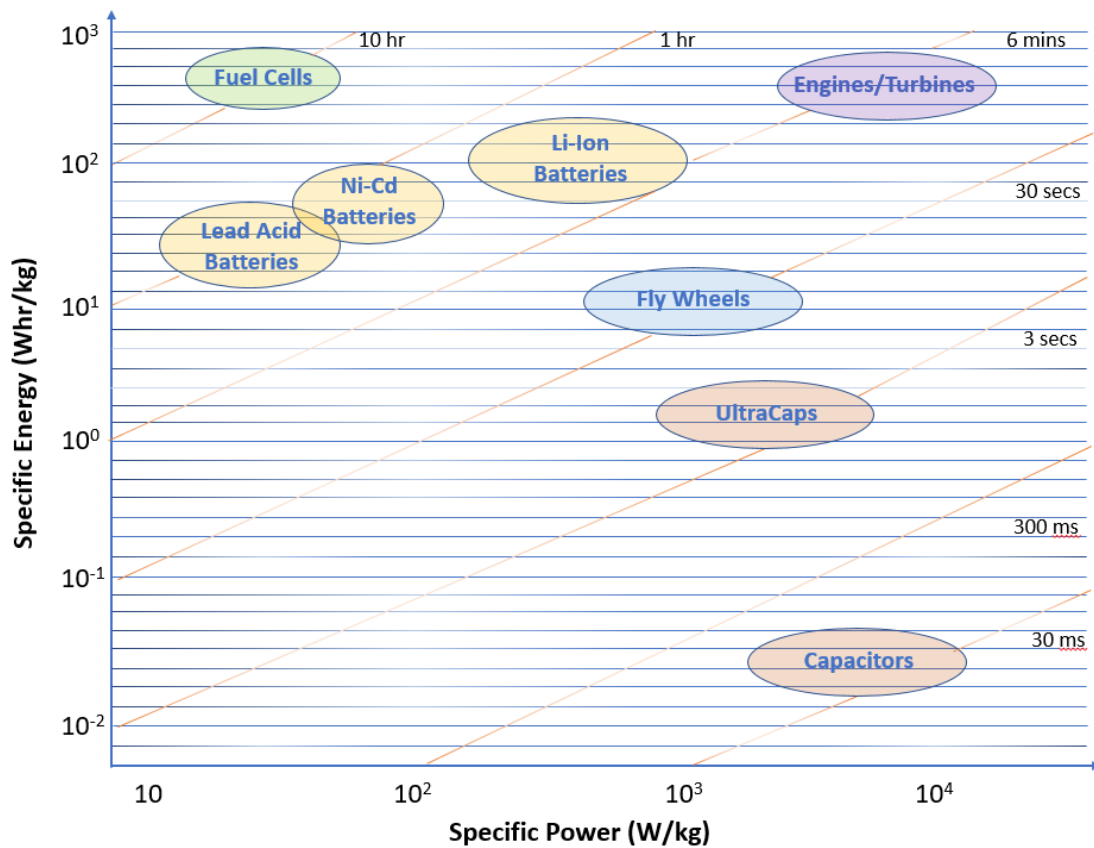

4-2.1.8 Candidate Evaluation Study.

The following considerations must be taken into account:

- Installation master plan and development plan with projected load growth
- Mission impact, allowable downtime, and required restoration time: facility or load ratings on the site depending on criticality
- Sample critical facilities list
- Available reports, energy audits, and studies
- Available historical data and studies regarding outages and potential natural disasters
- Documentation of frequency, duration, and magnitude of outages at target locations, existing CONOPS during outages, and operational capability gaps to improve or automate the CONOPS
- Existing electrical site loads and load profile

- Utility maps, one-line drawings, substation configuration, other electrical infrastructure information
- Generator lists
- Communications diagrams, network diagrams, and fiber diagrams
- Site drawings with significant buildings and features identified
- Site electrical load information (by buildings and equipment)
- Smart meter or AMI data, if available
- Load shedding, facility, and installation/utility restoration plans

4-2.1.9 Ability to Support Critical Facility Loads.

Microgrid candidate designs must be evaluated based on their ability to maximize the amount of critical load served. Design options serving greater amounts of critical load within project cost are considered more favorably. Facilities are characterized based on their level of service during microgrid operation. For each facility supported by the microgrid, NFPA 110 describes a Standard Classification of Emergency Power for Emergency and Standby Power Systems including:

- Installation, maintenance, operation, and testing requirements as they pertain to the performance of the emergency power supply system (EPSS).
- Class - minimum time, in hours, for which the EPSS is designed to operate at its rated load without being refueled or recharged.
- Type - maximum time that the EPSS will permit the load terminals of the transfer switch to be without acceptable electrical power.
- Level - two levels of equipment installation, performance, and maintenance.

4-2.1.10 Availability of Existing Infrastructure.

Candidate microgrid designs that leverage more existing capital assets are considered more favorably than candidate solutions that require significant replacement or upgrade and additional capital investment. The design must ensure existing infrastructure is adequate to support all operational conditions required by the microgrid.

4-2.1.11 Cost Estimate.

At the conceptual design phase, a cost estimate may be completed with a mix of vendor information and standard cost-estimating data. For specific high-cost elements (such as generators, energy storage systems, transformers, and renewable energy systems), designers must request preliminary vendor budget pricing information on the specific high-cost equipment being planned. The vendor is typically supplied with system performance specifications (as opposed to a detailed design specification), and will

typically provide the cost of a component(s) with allowance for installation, specification descriptions, and estimated delivery schedule. The budget information is non-binding and the budget must include an allowance for potential changes or unknowns. DD1391 has percentages assigned for these unknowns. Designers will also be responsible for identifying items such as management overhead, permits, and contingency. For cost estimating, refer to DoD Area Cost Factors by region.

Designers must update cost estimates throughout the design process. The cost estimate from the 10-15% design is more relevant to the authorization for funding than the initial planning estimate. Service-specific preferences and “buy American” clauses are key components of estimates. Refer to UFC 3-740-05 Section 8-2.2 and the Federal Acquisition Regulation (FAR) for further information on the “buy American” clause.

Local personnel or the relevant DoD agency can provide assistance with adjustment factors. See UFC 3-701-01 and UFC 3-730-01.

4-3 PRELIMINARY DESIGN (10-15%)

The preliminary design advances the conceptual design by considering feasibility of integrating existing infrastructure, equipment and control system requirements governed by installation standardization efforts, “constructability” of proposed infrastructure, developing modes of operation and performance metrics, and location/available footprint needs of new assets. The purpose of the preliminary design is for the government to produce a performance-driven scope of work and inform performance-based acquisition to produce a detailed design.

4-3.1 Preliminary Design Elements.

4-3.1.1 Detailed Load Analysis.

This includes higher fidelity load estimating, and power system analysis per UFC 3-501 and incorporates the following:

- AMI system, 15-minute metered data, feeder loading data, or some form of continuous output (if available)¹.
- Loads for non-metered facilities and equipment: the difference between total base load and AMI metered load can be used to estimate loads.
- Available load curves based on season, time of day, day of the week, holiday, workload, outside temperature, and operating information.
- Load specific information from facility engineers, onsite personnel, or system owners.
- Facility-dedicated generator loading data (this data may not represent normal facility loading if generator testing typically occurs during non-

¹ Existing generation should be taken into account when analyzing load data to ensure that the gross load is determined and not net load.

business or non-mission hours; therefore, it is important to run these generators under full emergency operations load simulating a grid outage when retrieving loading data).

4-3.1.2 Defining Storage Assets.

The below table (Table 4-3) is intended to aid planners and designers in reviewing the realities of energy storage options, prior to acquisition. Some options included for context are emerging or nascent technologies that are not currently available as commercial-off-the-shelf (COTS), or are infrequently used. Values assigned in the columns are estimated for the benefit of planners. All listed technologies are subject to individual considerations, for example, the lithium ion battery requires reliable air conditioning, due to the fire threat at high temperatures.

Table 4-3 Energy Storage-based DER (as of January 2023)

DER Type	Availability (COTS)	Hazardous Material Waste (EOL)	Energy Density	DoD History as Permanent Infrastructure	Lifecycle (Years)	Greenhouse Gas Emissions	Energy Time Provided Prior to Recharging
Fossil Fuel	Yes	State-Dependent	High	Yes	N/A	Yes	N/A
Iron Flow (BESS)	No	No	Low	No	25	No	Up to 12 Hours
Lead Acid	Yes	Yes	High	Yes	3-12	No	2 Hours
Lithium Ion	Yes	Yes	High	No	10	No	Up to 4 Hours
Compressed Air	No	No	Low	No	30	No	TBD
Fly Wheel (FESS)	Yes	No	Low	Yes	20	No	30 Minutes
Pumped Hydro	Yes	No	Low	Yes	>40	No	Up to 12 Hours
Super Capacitor	No	TBD	High	No	10-20	No	TBD
Hydrogen	No	No	TBD	No	N/A	No	N/A

4-3.1.3 Identifying Infrastructure Gaps and Deficiencies.

Infrastructure deficiencies and gaps must be identified prior to implementation of the networked system. This may include:

- Addressing areas in need of infrastructure improvement including additional generation, distribution capacity, or fiber communication capacity.
- Identifying mechanically inoperative breakers and switchgear that is not normally engaged.

- Recapitalization or other integration of legacy infrastructure to meet performance standards.

4-3.1.4 Continuity of Operation (CONOPS).

The basis of design must be informed by mission CONOPS requirements. This includes microgrid (or microgrid operator's) islanding, restoration sequence, and load shedding decisions. These design requirements must be reflected in the operating procedures and are the basis for programming the control system. During design development, designers must specify operating procedures and the exact behavior of individual equipment and control elements.

4-4 DETAILED (ENGINEERING) DESIGN.

The detailed design is the final design product of the performance-based acquisition. It specifies every aspect of construction, device type and interconnection, programming, cabling, wiring, and fiber. This is the engineering level specification that would be furnished to a bid-build contractor. The detailed design must include the following:

- Description of how all generation sources are integrated and configured into the network to best deliver firm, reliable power to the critical loads per UFC 3-410-02 and UFC 3-470-01.
- Devices: List of devices, device IDs, device attributes including type, model, location, dimension, rating, interconnection type and attribute (e.g., black start, grid-forming, droop-controlled, grid-following), software/firmware version, and communication protocols.
- Pathways and Conduits: List of utility conduits, fiber pathways, cable type/length, capacities, etc.
- Schematics and Diagrams: Device schematics, network diagrams, wiring diagrams, flow diagram, trenching plans, site designations, equipment specification, cut sheets, etc.
- States of Operation: A complete listing of each state of operation, order of events under each state. For each state of operation, the exact commands and actions taken by each asset/device/component and the expected result of all other devices in the system. This must include load restoration and load shedding sequences.
- Device Isolation: Description of generation bypass and other device isolation, loaded testing, step loading with planning for oversizing generation or ensuring loads can be added, removed, or segregated in manageable increments.
- Configuration management plan and implemental of procedures for controlling changes to the design baseline over time.
- Nonstandard hardware components needed on hand for O&M/Repair including spares, repair parts and supplies, tools, test equipment, etc.

- \1\ Construction sequencing, including testing timelines of switch-over of microgrid assets. Provide microgrid support of connected critical and non-critical loads during final commissioning to minimize impact to existing operational capabilities. /1/
- Equipment/System Documentation: In-depth operational training material for addressing step-by-step microgrid operation for each system condition and state of operation, common troubleshooting and maintenance procedures. This must include material to identify anomalous operation, and troubleshooting, vendor contact, and warranty information.

4-4.1 Aligning Microgrid Operation with Existing Infrastructure.

Microgrids leverage existing capital infrastructure with new power system assets and controls. Consequently, many design solutions may involve nontrivial levels of effort to validate proper operation of existing electrical systems, require specialized reprogramming of existing systems to support microgrid functionality intent, or involve other hardware or software costs. For new facilities to be “microgrid-ready”, construction must include paralleling switchgear at the point of electrical service as well as the following attributes for inverters.

- Programmable output capable of accepting an external control signal from the master controller (in some cases, inverter oversizing might be prudent to support both reactive power and planned real power needs)
- Adjustable inverter trip levels and clearing times
- Ability to network control signals from Microgrid master controller
- Logical output curtailment from Microgrid master controller
- Extended voltage and frequency operating ranges
- 4-quadrant operation and control (for new construction with battery-based storage)

4-4.2 Aligning Generation Sources for Islanded Operation.

Islanded operation requires black start generation to energize the islanded distribution, along with sufficient additional generation capacity to support full critical load.

4-4.3 Aligning Renewable Systems for Islanded Operation.

When interconnecting renewable sources of power to the installation power system, the inverter-based device must adhere to IEEE1547 Clause 8, including Anti-islanding and Ride-through requirements. During islanded operation, both grid-following and grid-forming sources can support islanded operation provided at least one black start, grid-forming asset is available in the islanded system. Systems solely containing renewable sources and energy storage must maintain sufficient state of charge (SOC) operating

margins to ensure mission assurance posture should commercial power be lost when renewable power is unavailable.

4-4.4 Aligning Controls and Switchgear for Islanded Operation.

All control systems and switchgear whose operation is required during black start operation must be fitted with a UPS (this is particularly applicable to switchgear that is not typically operated from a dead bus condition).

4-4.5 Aligning Switches and Transformers.

Devices that are normally configured for the flow of power in one direction must be certified by the manufacturer for bi-directional operation without negative impact to the life expectancy or warranty of the equipment.

This Page Intentionally Left Blank

CHAPTER 5 COMMISSIONING AND PERFORMANCE VALIDATION

The microgrid commissioning (or recommissioning) and testing planning must be received and approved by the government and independently supervised, verified, and certified by the government as fully functional. Microgrid commissioning ensures that:

- Each subsystem operates as designed
- The interconnected system operates in every state of operation as designed
- Design supports contingency of operations and installation emergency response plan
- The system meets each of the performance metrics used to inform design

The commissioning phase not only validates system operation using target performance metrics, but also identifies troubleshooting procedures that must inform training plan documents that facilitate efficient sustainment and operation. The commissioning phase is generally the most effective time to diagnose areas of improper operation of legacy capital assets, devices, and alignment of existing infrastructure components. Equally important, sequential operation of device assets and system-level commissioning allows designers to further optimize controls, device and relay settings, and device logic to achieve or exceed the respective performance targets. An independent, third-party validator is advisable during system commissioning. The validator must approve the system commissioning plan and validate fielded operational performance in accordance with each of the stated operational states, performance objectives, and metrics.

The commissioning phase includes the following steps:

- Commissioning plan
- Device/component level commissioning
- System-level commissioning

5-1 COMMISSIONING PLAN.

During system design, a detailed commissioning plan must be developed in parallel based on each operational state the system is designed to support (with a detailed sequence of operations for each scenario). The sequence of operations must state device configuration and expected result for each step of the test and record configuration of switchgear, device load factor, and indication of unexpected or anomalous operation. Load banks or energy storage devices can be integrated into the testing process to avoid unnecessary impact to active facilities that do not need to be disrupted for the early part of the testing procedure. An energy storage system may be used as a load rather than a load bank. Final system testing must demonstrate the system's ability to support actual targeted mission loads.

The commissioning plan must clearly identify performance metrics (see CHAPTER 3) and thresholds to be achieved for every operational state under test. Measurement and verification of all performance objectives must be explicitly stated in the commissioning plan. Commissioning must include all items needed on hand for O&M/Repair such as spares/repair parts/supplies/special tools/special test equipment. Develop a configuration management plan and implementation of procedures for controlling changes to the design baseline over time.

5-2 DEVICE/COMPONENT LEVEL COMMISSIONING.

Each device and subsystem component must be independently tested prior to system commissioning. The project construction plan generally includes equipment and software acceptance testing for each subsystem commissioning. Site staff must receive training before these stages and be involved in these processes as part of their training.

This includes start-up of each device using standard vendor (local) control to verify proper operation prior to interconnection with network (remote) control assets or other network equipment. Subsequent phases of device level commissioning must address remote operation of devices, verification that remote device operation is reflected and controlled at the master control location, as well as validation of device settings, timing, controls, paralleling, and protections. In some cases, testing of two or more microgrid elements prior to interconnection with the whole microgrid/grid is prudent (e.g., protection devices and islanded DERs). Each component of the commissioning must be designed to best simulate real world operations, under fully loaded conditions. This is especially critical during system-level commissioning.

5-3 SYSTEM-LEVEL COMMISSIONING.

Upon completion of component testing, system-level commissioning verifies the full system's capacity to react to an unplanned outage. This includes:

- Synchronize all of the local sources of power,
- Reenergizing critical loads in the appropriate sequence of restoration,
- Optimized load factor and operational endurance,
- Transition back to commercial power.

Close coordination with the commercial utility is encouraged to facilitate disconnection/reconnection to the external power system, as well as validate that the system meets all the technical requirements of the interconnection agreement. Commissioning must include all items needed on hand for O&M/Repair such as spares/repair parts/supplies/special tools/special test equipment.

5-3.1 Identify Software/Hardware Configuration Changes

System-level commissioning may identify software or hardware configurations needing further attention including switching operations, device timing, communications or fiber

functionality, inter-device coordination and protection settings, or devices requiring independent power to and other. During commissioning, breakers, switches, or other substation or facility equipment may require dedicated UPS, modification in set point, timing, or other re-programming to facilitate off-grid operation.

5-3.2 Validate Operational State

Each operational state of the system must be independently validated during commissioning including black start, microgrid formation, generator paralleling and islanded inverter-based device interconnection, supporting variable load states, ability to support load after during loss of generation or communications, fail safe operation, and safe reconnection back to commercial power. To the extent possible, metrics and targets must be assigned to each phase of the commissioning to quantify operational improvement resulting from microgrid operation, as well as to validate performance goals associated with the ERCIP Program and other DoD Installation Energy Resilience Policy.

A critical aspect of system commissioning is to operate in conditions as faithfully as normal installation conditions as possible. While device and initial system commissioning can take place during off-peak times (to minimize impact to business operations), microgrid performance cannot be fully validated until the system is exercised in a manner faithfully reproducing an unplanned utility outage under full load (with no ancillary connections or external sources of power). Utility system managers and facility engineers must work with tenants and mission stakeholders to facilitate such a “real world” microgrid system commissioning. This may include testing under normal loading, during normal business hours, etc. In some cases, mobile or other alternative contingency generation can be temporarily sited should testing and commissioning render existing stand by power systems inoperable.

5-3.3 Periodic Reverification Testing

There must be periodic reverification testing at intervals prescribed by the Operations and Maintenance Test plan, typically three to five years. System performance reverification and testing is performed by a qualified testing organization such as an AFCEC/COM (CEMIRT) type organization or by an approved commissioning contractor.

This Page Intentionally Left Blank

CHAPTER 6 SEQUENCE OF OPERATIONS

6-1 STATES OF OPERATION.

Islanding and reconnection to the commercial utility must be performed safely and seamlessly to the priority loads. The microgrid controller must support the elements of power system interoperability per IEEE 2030 and is responsible for each state transition, each associated sequence of operation, and visualization of the distribution system and generation asset output under all conditions. The following items are typical microgrid states of operation (some alternatives are possible for systems with adjustable droop-type controls, closed-loop fast-feedback controls, PMUs or other devices):

- Normal operation (grid-connected, standby)
- Isolation from external utility (islanding)
- Microgrid formation (soft transition or black start)
- Islanded operation (optimized operation for resilience and endurance)
- Re-synchronization back to external utility (soft transition only)
- Testing and diagnostic mode (supports regularly scheduled loaded testing, device testing, and troubleshooting)

There are two primary scenarios for totally disconnecting from the grid: emergency disconnect (unplanned disconnect as the result of grid failure) and planned disconnect. This is done in anticipation of an impending failure or for business reasons, such as operation as part of a Voluntary Protection Program (VPP) in support of the local utility.

An example of how the system can manage these operations is provided in UFC 3-540-08, Chapter 8. This reference covers information related to utility relations and financial incentives.

6-1.1 Normal Operation (Grid-Connected, Standby).

This is the normal state of operation. The system remains in standby and awaits a grid event to notify a human operator or take autonomous action.

6-1.2 Isolation from External Utility.

Upon unscheduled loss of utility power, all facility loads are lost¹, renewable generation systems disconnect, and the system controller begins a timer (based on a programmable time delay parameter). Should stable utility power resume within this period, no action is taken. If the utility power is not restored within the programmed time, the operator or system commits to entering islanded operation and issues a command

¹ Blinkless designs running parallel with the external grid may not lose power during islanding (paragraph 3-4).

to open the interconnecting breaker(s) or recloser(s) at the point(s) of common coupling (PCCs), and system boundaries are established (IEEE 1547 Clause 8).

6-1.3 Microgrid Formation.

All microgrid systems must be capable of black start (reenergizing the microgrid island after unplanned grid failure with no energized generation resources). Because there is no utility reference, the resources must be able to define their own reference frequency and synchronize all resources uniformly to the reference. A start-up command is sent to black-start generators under microgrid control that are not dedicated to facilities (regardless of magnitude of connected load prior to the outage). The first networked generator to reach the rated voltage and frequency connects (provides power) to the distribution bus, and operates under synchronous control mode (subsequent generators and inverter-based systems joining the network operate in droop control mode). For microgrid designs with fully distributed, agent-based control, this generator (and its local controller) can be designated as the master controller by the rest of the controllers (this avoids having a predetermined master control point which could be a single point of failure should its generator or communications be lost during start up). Under this logic, each of the subsequent generators' voltage, frequency and phase are matched to the master/bus voltage, frequency, and phase before their respective paralleling breakers close to the bus. As previously mentioned, controls and switchgear whose operation is required for black start should be fitted with UPS (this is particularly applicable to switchgear that is not typically operated from a dead bus condition).

If the system is responsible for supporting facilities with dedicated backup generators, the automatic transfer switch (ATS) at each facility generator detects loss of power on its normal side and transfers to emergency (generator) position and each facility generator starts (see Figure 1-4). Once all facility generators have restored their respective loads, the microgrid closes its breaker between the emergency side of the ATS and the secondary side the facility transformer to allow the facility generator to feed the transformer and outside distribution system. Once the ATS determines its normal side is energized with stable voltage, it switches back to its normal position to allow the facility generators to energize the distribution system, depending on the relevant topology. Once all generators are online, paralleled, and the master controller is defined, breakers at the facility loads are closed to the bus in a predefined sequence corresponding to the installation's facility load restoration plan. The system monitors system load as these breakers are closed and issues a stop command once it determines that the load has reached a level corresponding to the N+1 generator redundancy target (i.e. should any generator fail to maintain load or be e-stopped, the system still maintains the energized network at that load level). The system never commits the generator network to a higher load than this, unless specifically commanded by a human user.

6-1.3.1 High-Speed and Low-Speed Controls and Operation.

Microgrids manage every aspect of the power system including islanding, paralleling, interconnection, system protection, load following, and renewable energy management.

Microgrid control takes place at two levels: high-speed controls and low-speed controls. The two levels of microgrid control are comparable to an individual controlling a modern automobile (the driver sends comparatively slow commands to the vehicle, while the vehicle control system responds accordingly by issuing commands to internal vehicle systems at much faster response times).

6-1.3.1.1 High-Speed Control Functions.

First, the phase and frequency is set by a master source controller, and is followed by the other generators to synchronize systems using high-speed, sub-cycle generator controllers. These device-level, high-speed controllers and governors manage voltage and frequency output and other high-speed parameters relating to electrical power stability. These are used to synchronize and measure electrical magnitude and phase angle of electricity as well as to synchronize time and coordinate the distributed power sources prior to merging.

6-1.3.1.2 Low-Speed Control Functions.

While the high-speed system is programmed to verify that all the prime movers on the system are synchronized, it may not monitor operational set points, load factors and power output. These attributes are optimized by a low-speed control supervisory controller, which manages distributed control points over slower communications. Given a specific operational scenario, the system issues commands to generator controllers and energy storage for each asset to compensate for renewable energy output fluctuation, load variation, demand response programs, etc. A microgrid system's low speed control is also responsible for:

- Management of renewable energy system output
- Management of energy storage
- Optimization of fossil fuel based generation load factors
- Dynamic load following
- Optimization of network efficiency and endurance

6-1.4 Islanded Operation for Resilience and Endurance.

Once the full load is served, the microgrid can optimize operation by 1) Managing load factor of paralleled generation 2) Paralleling inverter-based generation devices, and 3) Shedding discretionary loads to increase system endurance.

The system begins to optimize load factor at each generator unit and shuts off units if the load can be supported with fewer units running (at higher load factors). Should each of the running units be operating below a threshold load factor (for example, 50 percent), one generator is commanded to shut down to increase load factor of the remaining units. Conversely, should each of the running units be operating over a threshold load factor (for example, 80 percent), an additional DER or energy storage

service is engaged in reserve to rapidly ramp up in case a load spike occurs during this time.

By this time, inverter based (renewable) assets have sensed the energized system and begin to provide renewable power (for example, PV) or stored energy (for example, 4-quadrant energy storage devices) to the network, thereby deferring the amount of power the generator fleet must deliver.

The microgrid master controller continuously iterates the full network optimization based on the changes in load, renewable energy availability, state of charge of storage devices, and status of generator/fuel availability. Finally, the system may open breakers to discretionary loads to meet system endurance targets during extended utility outages. Load shedding actions may be triggered based on pre-determined thresholds including remaining fuel levels, devices state(s) of charge, or projected remaining overall system endurance.

6-1.5 Re-Synchronization Back to External Utility (Soft Transition Only).

Once the system detects utility power has returned on the primary side of the PCC, it waits a predefined period of time to determine if the utility is stable and begins the process to soft transition back to commercial power. Because the microgrid's signal will likely be out of phase with the utility, the system phase locks the utility's phase with the microgrid by waiting for the microgrid signal's phase to align with the incoming utility signal's phase, synchronizes the systems and closes the substation breaker. \1\ Utilize load control logic to walk the load from the microgrid to the utility system progressively to ensure that the utility is not block loaded.

NOTE: Total transition time will be dependent upon system response and utility protection scheme requirements. /1/

Loads not supported by the microgrid are slowly added, sequentially; the objective is to maintain a steady escalation of power and avoid a disturbance that trips the breakers. Once all loads are online, the microgrid issues shut down commands to its networked generator fleet.

6-1.6 Testing and Diagnostic Mode.

The microgrid system must be tested periodically verify proper operational capability. Testing must be monthly or quarterly (as often as the mission allows) to verify working order of the equipment and system. Testing can incorporate emergency generator testing and can allow sources to be tested under load while mitigating unnecessary facility outages associated with moving to and from generator power. Refer to paragraph 7-2 for further information on testing.

\1\ **NOTE:** Full system testing should be performed on an annual basis as operational considerations allow. Partial testing of system components or modules may be done on a cyclical basis, i.e., generators one month, switchgear another, BESS the following month, etc. /1/

6-2 UTILITY CONSIDERATIONS.

See UFC 3-540-08, Chapter 8 for information related to utility relations and financial incentives. An example of such utility incentives can be found at California Public Utilities Commission Rule 21.

6-2.1 Utility Interconnection and Secure Islanding.

A properly designed microgrid can become a resource during normal operations to self-manage power consumption and cost, independent of the commercial utility provider. Installation personnel can also use the microgrid to negotiate alternative rate structures with the utility in exchange for cooperation in managing the grid loads. Some commercial utilities have significant limitations with respect to interconnection agreements, including limitations on: power export, operating in parallel with the external grid, device isolation/lock out requirements, etc. Early discussion with the commercial power provider must be part of the preliminary background data gathering. Bases are encouraged to use any available Utility Company Fast Track / Pre-Application processes, whenever possible.

Designers must coordinate with the local commercial power utility to identify microgrid performance and interconnection requirements relating to islanding, protection, and paralleling (if permitted by the grid operator). Depending on the nature of the site and prevailing utility contractual arrangements, technical discussions may be necessary to address system operation when grid-connected. Discussions must include options for regularly scheduled demand reduction, power export, and paralleling with the utility if possible. When this is not possible, “hard transitions” to islanded operation could be necessary, and even then, utility operators may allow “soft transitions” to utility power by having the site remain on microgrid power following phase-lock resynchronization to the grid. This approach allows load to be gradually shifted back to the commercial power system, once it is restored and stable.

When developing the microgrid project, it is prudent to perform energy audits of the loads within the microgrid boundary in order to identify opportunities to reduce load, thereby reducing microgrid size and cost. Communication with the local electric utility should include the process for adding future electrical load within the microgrid boundary as operations move from current fossil-fueled operations to carbon-free energy supply. As noted above, it is critical to involve utility representatives early in the design process to discuss tariff interactions, policy guardrails, and the interconnection process, which can be lengthy given the potential size and complexity of these projects. For example, Southern California Edison (SCE) Account Managers in SCE’s Business Customer Division helps manage interconnection process and provides information related to available incentive programs.

6-2.2 Commercial Utility Relations.

Establishing a microgrid can significantly change the business relationship between the military installation and commercial utility. If the installation uses a standard large

service rate-structure contract, the microgrid can be used to manage energy and reduce the installation's cost under its existing agreement. Additionally, the opportunity exists to coordinate the microgrid with commercial utility's operation; in such cases, the commercial utility may offer a modified rate schedule in exchange for a benefit. The commercial utility may be able to invest in the project capital or operating cost budget.

The Federal Energy Regulatory Commission establishes reserve requirements for utilities. Many utilities will offer alternative rate structures with incentives to customers if the customers can help reduce the need for utility investment in reserve resources (which are expensive and produce little or no revenue).

Curtailed Service: In exchange for rate benefits, the customer agrees to reduce power usage according to a mutually agreed upon schedule. **Distributed System Generation (DSG):** In exchange for benefits, the customer agrees to bring generators online at the request of the utility. There are limits on the amount of power that must be provided by the customer and the customer has the right to refuse under certain circumstances.

All networked devices and systems must be in compliance with IEEE 1547 Chapter 8 requirements. Inverter based devices must comply with UL 1741.

Special design attention must be given to cases requiring accommodation of the following:

- Paralleling with the commercial utility grid (if permitted by the grid operator)
- Interconnection of "blinkless" devices intended to continually parallel with the utility in order to provide soft transition in and out of islanded operation
- Special operational needs and requirements of grid operators of smaller utility systems that may allow wider grid operating ranges involving customized calibration and field validation of controls, protection, and isolation.

CHAPTER 7 OPERATIONS AND SUSTAINMENT CONSIDERATIONS

Long-term, user-friendly, and sustainable operation is the primary consideration of all aspects of design, commissioning, training, and transitioning of the microgrid system. While automation and device-integrated controls represent valuable opportunities to improve mission resilience and system efficiency, such capabilities must be integrated into the system transparently, intuitively, and easily managed by installation public works personnel. Systems must have the capacity to operate safely, securely, and logically with maximized operational visibility over the lifecycle. \1\ /1/ Note that Air Force microgrids require a 7-day fuel plan but that is not intended to state that USAF policy is to island for 7 days. A 7-day fuel plan is designed so that all USAF generators have a plan to operate beyond their local storage requirement. Other areas of consideration may include the following:

- Automated operation and restoration sequences consistent with installation and mission CONOPS
- Provisions for testing including testing under load (as well as use of load banks)
- Testing controls
- Startup and RE integration sequence
- Integration with existing or planned supervisory control and data system/ industrial control system (SCADA/ICS) based grid operation
- Real time user visibility to operational metrics
- HMI based user accessibility
- Standardized ICS configuration management for streamlined operation
- Cyber sustainment and re-configurability

7-1 SYSTEM TRAINING.

To successfully transition a complex microgrid system from design to operation, personnel training is critical. Implement training using information acquired during the detailed engineering design phase.

The training material and strategy must be customized to the specific installation and complexity of the microgrid system. Additional roles and responsibilities may be added including: CIO and cybersecurity hygiene, ICS maintenance, operation of HMI, and SCADA familiarity, etc. Separate training regiments must be considered and developed for each role/responsibility (public works officers, CIO, operators, maintenance personnel).

Specific personnel needs must be determined based on lessons learned during commissioning, as well as interviews with key personnel to account for current

operations, focus areas, and roles. Training material and strategy must be updated appropriately to reflect system improvements and modifications.

7-2 PERIODIC OPERATIONAL TESTING.

Periodic testing of the microgrid system provides higher confidence in generator readiness and familiarity by operators during times of need. Testing can be monthly or quarterly to verify working order of the equipment and system. At a minimum, the system must be tested for black start annually (this can be coordinated with DoD's Energy Resilience Readiness Exercises). If facility-level DERs are part of the microgrid, testing must be coordinated with facility generator testing per UFC 3-540-01. Generator assets must be tested in accordance with maintenance intervals and procedures as prescribed by the manufacturers. Load banks must only be used where no alternative exists to test the system under load without unacceptable mission disruption.

Testing must include operating generation under variable load factors and with reduced mission disruption or hard transition to end users (moving to and from generator power). This can be facilitated by operating the system in parallel with the external grid or redirecting power via looped distribution systems. This will also test the microgrid's ability to island and black start all supported mission loads without external grid support (per DoD Framework for Planning and Executing Black Start Exercises). Testing under real world mission and load conditions is strongly recommended.

Microgrid performance results (as required by each service) must be kept on file with annual reporting of the overall system status to the office of responsibility for system certification.

APPENDIX A MICROGRID BACKGROUND INFORMATION

A-1 MICROGRIDS AND DOD INSTALLATION ENERGY POLICY.

Microgrids and Networked standby solutions advance 3 broad areas of DoD installation policy; 1) Mission Resilience and Off-Grid Endurance, 2) Increased Utilization of Renewable Energy Systems, and 3) Consolidated Cybersecurity within Defined Network Boundaries with Defense in Depth.

A-1.1 Executive Orders

EO 14057 sets high standards for many items, including the use of renewable energy in federal buildings; 30 percent of the electrical energy consumed by federal agencies must be renewable by fiscal year 2025 and each year thereafter (note the goal is an aggregate and does not apply to each building individually). Microgrids are an effective means of using renewable energy during grid power outage situations. By effectively using microgrid resources (hardware, control systems, and software), the penetration of renewable energy may be increased during normal operation.

A-2 LOAD CHARACTERIZATION USING AMI DATA.

Load information is used to determine microgrid resources needed and for designing the microgrid system. During the initial study, the feasibility load analysis can be challenging. An AMI system, which is increasingly used, can provide detailed data. However, for specific loads, AMI data may not be available. During the feasibility study, designers must estimate load with sufficient confidence process using available information. If confidence is acceptable, designers may proceed with feasibility knowing that higher-fidelity data may inform preliminary design. Alternatively, designers may choose to pause, selectively install AMI equipment, and gather additional data before readdressing the load analysis problem.

Areas to consider for thermal and non-electrical load analysis include:

- Magnitude of Real (Watts) and Reactive (Vars) power for each phase and total
- Apparent Power in VAs for each phase and Total
- Prevalence of volatile, high-ramp rate loads, or other load following requirements
- Prevalence of Specialty or Industrial loads with motor start requirements or potential for Phase imbalance impact
- Power Factor for each phase and average
- Averages of Energy in kWh and Reactive
- Rated capacities of infrastructure
- Seasonal effects of temperature and usage

- Derating factors for equipment
- Theoretical additional load information

APPENDIX B ANALYSIS AND DESIGN MODELING TOOLS

B-1 ANALYSIS TOOLS.

Power System and Utility Modeling may include the following:

- Short Circuit Analysis: Calculates the maximum available fault current at each bus in the system
- Arc-Flash Analysis: Determines the duration, amount of energy released, and minimum distance required to protect an individual from an arc-flash
- Load Flow Analysis: Provides magnitude and phase angle of the voltage at each bus and the real and reactive power in each feeder; analysis includes generators, transformers, and renewable resources
- Voltage Profile Analysis: Load-flow analysis is used to develop voltage profiles for each scenario; this is particularly important when renewable resources are included in the system as rapid output swings may introduce instability in the system; instabilities that may not be a problem for a large utility grid may be an issue for a microgrid
- Coordination Studies: Determines the proper time versus current settings for medium-voltage relays based on feeder cables, transformer inrush current, generator size, and time-current setting of other equipment; objectives include devising relay settings to be tolerant to normal events such as inrush currents and still provide maximum protection from failure (fault) events, and having downstream circuit breakers clear first, thus compartmentalizing the outage to the smallest subsystem

Additional considerations are as listed:

- Analyzing Allowable Contribution of inverter-based power generation assets
- Grid tolerance and Grid Characterization and Modeling (if installation determines highly stressed grid or high RE penetration)

B-2 MICROGRID DESIGN MODELING TOOLS.

In accordance with Section 2911 of Title 10, DoD is required to use tools that are accurate and effective in projecting the costs and performance of potential microgrids. This appendix serves to define those requirements and provide a list of tools currently meeting these requirements, which may be used in developing microgrid projects and assessing alternatives. As microgrid design tools continue to evolve, this Appendix will be updated every three years.

Microgrid design tools are used to create conceptual designs at approximately the 10% to 20% design level and provide estimates for system performance and life cycle costs. They are used by the government to consider design alternatives, project cost

estimates, establish RFP requirements, and assess alternative designs. Private sector engineering firms use them in combination with utility design tools to develop 100% designs.

B-2.1 Modeling Tool Requirements.

Section 2911 requires DoD to use tools to design and assess microgrid options. Tools must:

- Provide an accurate projection of the costs and performance of the energy resilience measure being analyzed,
- Produce resulting data that is understandable and usable,
- Consistent with standards and analytical tools commonly applied by the Department of Energy and by commercial industry,
- Adaptable to accommodate a rapidly changing technological environment,
- Peer reviewed for quality and precision,
- Measured against the highest level of development for such tools.

The following provides an assessment of available microgrid design tools relative to these requirements. Only microgrid design tools that meet Section 2911 of Title 10 requirements should be used to develop conceptual designs for DoD installation microgrids, assess cost and performance tradeoffs, and establish the requirements for future proposals for detailed designs. From the tools that meet Section 2911 requirements, installations should select one based on the design issues relevant for their installation.

B-2.1.1 Costs Requirements.

Accurate projection of costs requires the following information on finances, DER costs, and utility tariffs:

- **Finances:** Transparent analysis period, inflation, and discount rates are required to ensure lifecycle financial calculations are accurate and meet projects' requirements and current financial conditions.
- **DER Costs:** Transparent assumptions on the capitol and O&M costs of all DERs being modeled that are consistent with industry practices and that can be modified to account for changing technologies.
- **Utility Tariffs:** Ability to accurately model utility tariff structure used by installations. Factors to consider include energy costs, demand charges, and time of use rates as needed.

B-2.1.2 Performance Requirements.

Accurate projection of performance requires the following information on installation energy loads and DER performance:

- **Energy Load:** The installations total and critical load at a resolution of one hour or less for an entire year is used to calculate the system's performance.
- **DER Performance:** Renewable and conventional DER performance is modeled using transparent techniques that are consistent with industry practices and can be updated to account for changing technologies.

B-2.1.3 Peer Review Requirement.

The model has been peer reviewed through publication in scientific or engineering journals.

B-2.2 Tools Reviewed.

Recent reviews^{1,2,3} of existing software solutions and tools developed through DoD funding led to the consideration of the following conceptual design tools:

1. **DER-CAM** (Distributed Energy Resources Customer Adoption Model) is a decision support tool that can find optimal distributed energy resource (DER) investments for multi-energy microgrids developed and supported by Lawrence Berkeley National Laboratory (<https://gridintegration.lbl.gov/der-cam>). DER-CAM is publicly available and free to use.
2. **DER-VET** (<https://www.der-vet.com/>) developed and supported by the Electric Power Research Institute, is a free, publicly accessible, open-source platform that can optimize the value of distributed energy resources (DER) based on their technical merits and constraints for microgrids. It determines optimal size, duration, and other characteristics for maximizing benefits based on site conditions and the value that can be extracted from targeted use cases.
3. **ERA** (Energy Resilience Assessment) is a tool designed and supported by MIT Lincoln Laboratory that assists installations and missions to explore alternative microgrid technology solutions for meeting critical power requirements. It performs a system analysis of alternatives based on life

¹ Microgrid Analysis Tools Summary, <https://www.nrel.gov/docs/fy18osti/70578.pdf>

² A review of microgrid development in the United States – A decade of progress on policies, demonstrations, controls, and software tools, Applied Energy, Volume 228

³ Assessment of Existing Capabilities and Future Needs for Designing Networked Microgrids, SAND2019-2436

cycle cost and ability to meet the critical load. It is a web-based tool that requires a DoD Common Access Card to access.

4. **HOMER** is a microgrid design software tool originally developed at the National Renewable Energy Laboratory and enhanced and distributed by HOMER Energy (<https://www.homerenergy.com/products/pro/index.html>). It provides simulations of grid-connected microgrid systems that combine traditionally generated and renewable power, storage, and load management. Access to the tool requires a licensing fee.
5. **MDT** (Microgrid Design Toolkit) is a free decision support software tool (<https://energy.sandia.gov/download-sandias-microgrid-design-toolkit-mdt/>) designed and supported by Sandia National Laboratory for microgrid designers in the early stages of the design process. The software employs powerful search algorithms to identify and characterize the trade space of alternative microgrid design decisions in terms of user-defined objectives.
6. **MicrogridUP** is a recently developed tool by National Rural Electric Cooperative Association (NRECA) (<https://microgridup.org>). It leverages DOE-developed solutions to lower microgrid planning costs to DoD by developing a repeatable microgrid planning framework that simplifies the process of planning for the integration of assets with legacy infrastructure. The tool is publicly available at no cost.
7. **NPS Tool** was developed by the Naval Post Graduate School (NPS) and the University of Wisconsin - Milwaukee (<https://microgrid.nsetti.nps.edu/>). A simple API is currently available and a microgrid simulation tool is under development. The tool is sponsored by Navy Shore Energy Technology Transition and Integration and Energy System Technology Evaluation and Program Office of Naval Research.
8. **REopt** was developed and supported by the National Renewable Energy Laboratory (<https://reopt.nrel.gov/>) and is a free decision support platform that evaluates how renewable energy and storage can be incorporated alongside conventional generation in grid-connected microgrids to meet critical loads at the lowest life cycle cost. REopt optimizes a microgrid system's DERs to provide ongoing economic savings and extend site survivability during outages.
9. **XENDEE** provides a microgrid design support system (<https://xendee.com/>) that implements a physically based economic tool that couples financial optimization with detailed electrical power system analysis to verify resilience and financial viability. XENDEE provides support through a subscription-based service for initial feasibility studies through balance of system engineering analysis.
10. **HelioScope** is an industry leading software platform for designing high-performance solar arrays. Folsom Labs developed HelioScope, an advanced solar PV design tool.

11. **Resilience and Cost Assessment Tool** was developed by NAVFAC EXWC, creating resilience and cost models implemented with a corresponding methodology, “Resilience Assessment of Islanded Renewable Energy Microgrids.” The methodology generates the resilience and cost trade space for a site specific location. This tool enables more informed decisions on microgrids by being able to choose the microgrid architecture that provides the most cost effective resilience. The Naval Post Graduate School adapted the models to a web-based object-oriented design API incorporating the initial methodology. The tool’s development was sponsored by Navy Shore Energy Technology Transition and Integration, and Energy System Technology Evaluation and Program Office of Naval Research.

Table B-1 provides an assessment of these microgrid design tools with respect to costs of use, evaluating system performance, and peer review.

Table B-1 Microgrid Design Tools & Section 2911 Requirement Status

	Costs	Performance	Peer Review
DER-CAM	Yes	Yes	Yes
DER-VET	Yes	Yes	Yes
ERA	No	No	No
HOMER	Yes	Yes	Yes
MDT	Yes	Yes	Yes
MicrogridUp ¹	Yes	Yes	No
NPS Tool ²	No	No	Yes
REopt	Yes	Yes	Yes
XENDEE	Yes	Yes	Yes

¹ A peer review article on MicrogridUP tool will be published in 2023.

² NPS plans to expand their tools capabilities to meet Section 2911 performance and cost requirements over the next few years.

The DER-CAM, DER-VET, HOMER, MDT, MicrogridUP, Reopt, and Xendee all meet Section 2911 requirements and may be used by DoD for the component of conceptual design shown under Table 4-1 to establish performance and costs options, and compare alternative opportunities. Neither ERA nor the NPS Tool meet the statutory requirements and should not be used for microgrid design work. Other tools that can demonstrate they meet these performance requirements may also be used.

This Page Intentionally Left Blank

APPENDIX C CYBERSECURITY FOR MICROGRIDS

Appendix C discusses cybersecurity as it pertains to microgrids.

The design must include strategies to assure that a cyber-attack on the grid does not also compromise the microgrid. Microgrid control design must follow the published UFC 4-010-06 for Cybersecurity of Facility-Related Control Systems. The current approach relies on a more holistic strategy of building security in, not bolting it on.

Based on the organizational mission and details of the control system, the System Owner and Authorizing Official (AO) determines impact levels (LOW, MODERATE, or HIGH) for the control system per UFC 4-010-06.

C-1 APPLYING RISK MANAGEMENT FRAMEWORK TO MICROGRID CONTROLS SYSTEMS

All microgrid control system designs must follow the Risk Management Framework (RMF) which details how risk management is applied to DoD information systems. As defined by the National Institute of Standard and Technology (NIST), the RMF is “the process of managing risks to organizational operations (including mission, functions, image, reputation), organizational assets, individuals, other organizations, and the Nation, resulting from the operation of an information system, and includes: (i) the conduct of a risk assessment; (ii) the implementation of a risk mitigation strategy; and (iii) employment techniques and procedures for the continuous monitoring of the security state of the information system.”

Within DoD, each agency has an AO who determines the “Authority To Operate (ATO)” based on risk, and approves the final implementation (representing minimized, well-managed risk). When applying RMF to microgrid controls systems, the network boundary should include all control points and IP-addressable assets constructed as part of, or controlled by, the microgrid system.

Facility control systems are not information technology (IT) systems; they should not use standard IT system approaches and should not be connected to public systems, especially internet systems, and should not have remote access. The public internet system is one path for cyber-attack.

This Page Intentionally Left Blank

APPENDIX D LESSONS LEARNED AND EXAMPLES

D-1 LESSONS LEARNED.

D-1.1 Acquisition Lessons Learned.

Since microgrids cannot be procured as a single system, efficacy and competence of the final product is a function of systems integration. To the extent possible, acquisition should be "full and open" and based on "best value" with appropriate weight on performance metrics, technical approach, and past experience.

D-1.2 Design Lessons Learned.

At the preliminary design phase, performance metrics should be used to inform best-value design acquisition for both Design-Build and Design-Bid-Build. The government should seek detail regarding expected performance metrics and the level of detail of controls design needed prior to issuance of construction contract. Typically, government contracts don't include specific language requiring exact sequence of operation and expected outcome of each action and reaction of all equipment. As such, ensure that it is done in the request for proposal stage.

D-1.3 Operations Lessons Learned.

D-1.3.1 Power Critical Communications Nodes and Servers.

A number of critical communications nodes and servers lacked sufficient or functional UPS and generation backup power systems resulting in widespread NIPR (Non-Classified Internet Protocol Router) and SIPR (Secure Internet Protocol Router) outages. Power and SIPR outages at Command Centers would have significantly degraded operations in the event of an urgent task. Connect these nodes to the microgrid, add local backup power systems with enough capacity to bridge transition times as needed, and re-test.

D-1.3.2 Identify UPS Maintenance Contract.

No standardized maintenance contract exists to support UPS units on the installation, and the party responsible for funding and overseeing maintenance is often unclear. Identify a plan to obtain a site-wide UPS maintenance contract outlining clear roles and responsibilities.

D-1.3.3 Preserve Copper Landlines.

Copper landlines are still the primary voice backbone for some bases and is a reliable system. Ensure personnel are aware that these services will function during a power outage.

D-1.3.4 Update Critical Facility Lists.

A prioritized critical facility list was unavailable during the exercise, delaying responses to important facilities. Create a list and review it with all mission owners, support services, and installation leadership.

D-1.3.5 Resolve Nuisance Fire Alarms.

Address nuisance fire alarm issues to prevent significant disruptions to missions and to ensure that critical resources are available to respond to real emergencies.

D-1.3.6 Conduct a Long-duration Test for the Entire Installation.

Conduct a long-duration (ideally multi-day) installation-wide outage to demonstrate refueling, and to fully evaluate communications interdependencies and backup power systems for facilities not connected to the microgrid. A commercial cellular communications outage inject would also be useful to ensure bases are prepared for an unplanned, long-duration, regional power outage.

D-1.3.7 Integrate Findings into the Installation Energy Plan.

Integrate lessons learned from the microgrid test into drafting the base Installation Energy Plan.

D-1.3.8 Create Preemptive Warning Prior to Non-critical Generation Shutdown.

Ensure microgrid operators have preemptive flags alerting them of an impending problem with generation units that is not critical (e.g., Tier 4 emissions) and develop a procedure to override during outage conditions.

D-1.3.9 Train Sufficient Microgrid Operators.

Ensure there are enough trained microgrid operators for continuity of operations in the event of a long-duration outage scenario.

D-1.3.10 Improve Microgrid Power Control System.

Consider the development of an automated procedure to bring the entire installation online in the event that sufficient generation capacity exists. Continue to mature the PCS software and document lessons-learned.

D-1.3.11 Evaluate the Advanced Metering Infrastructure (AMI) and SCADA system.

This will determine if additional benefit can be gained by connecting legacy infrastructure into the new microgrid system. Leveraging all utility equipment into the microgrid system could greatly strengthen capability.

D-1.3.12 Improve Microgrid Power Quality.

Address power quality concerns with the microgrid, both through distribution system devices (e.g., battery energy storage systems and capacitors) and at the local level, and continue to engage with mission owners that have expressed concerns to increase their confidence to operate this equipment in a future exercise.

D-1.3.13 Document Microgrid Lessons Learned.

Consider the development of a living microgrid lessons-learned document that can be shared broadly across DoD.

D-2 PROJECT EXAMPLES.

D-2.1 Sample of DD1391.

1. COMPONENT ARMY/NAVY/USAF	FACILITY ENERGY IMPROVEMENTS			2. DATE 11 Jan 2022
3. INSTALLATION AND LOCATION		4. PROJECT TITLE: Energy Security Microgrid for Critical Facilities		
5. PROGRAM ELEMENT ECIP	6. CATEGORY CODE Multiple	7. PROJECT NUMBER P-123	8. PROJECT COST (\$000)	
9. COST ESTIMATES				
ITEM	U/M	QUANTITY	UNIT COST	COST (\$000)
Energy Security/Microgrid				
Natural Gas Generation (Capacity)	EA			
Diesel Generation (Capacity)	EA			
Energy Storage (Capacity)	EA			
Building for Generation plus Interconnection Equipment	EA			
Loads & Control	LS			
System Integrator & Controller	LS			
Cyber security equipment, testing, and upgrades	LS			
<u>MATERIAL AND LABOR SUB-TOTAL</u>				
General Provisions (25%)				
Contingency (5%)				
<u>SUB-TOTAL</u>				
SIOH (5.7%)				
<u>TOTAL PROJECT COST</u>				
Engineering Design (4%)				
<u>TOTAL FUNDING COST</u>				
<u>10. DESCRIPTION OF PROPOSED CONSTRUCTION:</u>				
<u>Executive Summary of Project Benefits:</u>				
<ul style="list-style-type: none"> ✓ Financial – The project has a payback of 25 years depending on the use and application of the microgrid. Energy cost savings were identified through demand response programs with the local utility and the value of energy security was analyzed and savings were determined by NREL ✓ Energy Savings – The benefits to the project go beyond energy savings as the project will demonstrate a never before achieved capability for installation wide renewable integration in a microgrid. ✓ Goals – This project will achieve Campaign Plan goal for energy independence by as well as meet many challenges from the DoD to achieve energy security. ✓ Energy Security – This project will provide energy security to all critical facilities with the use of renewable energy, energy storage, and convention fuel. This microgrid will power hundreds of buildings on the mission critical side. ✓ Synergistic Effect – This project will integrate many technologies such as renewable energy, direct digital controls, industrial control systems, energy storage, advanced metering, and SCADA. This microgrid project is designed to be scalable to accommodate future mission critical facilities added to the installation. 				

Table D-1 below shows San Diego Gas and Electric (SDG&E) Reliability Numbers. This calculation assumes a higher probability of large duration outages for the bases than has been historically observed. The future probability of outages is expected to increase but the magnitude of any reliability change is unknown. Between 2001 and 2010 for SDG&E, the average annual outage interruption per customer was approximately 1h and 45 minutes, and the average annual number of interruptions per customer was 0.7.

Table D-1 Example SAIDI/SAIFI Reliability Numbers

CRITERIA	SAIDI	SAIFI
Including CPUC Major Events (2010)	89.77	0.863
Excluding CPUC Major Events (2010)	67.74	0.543
10-Year Average (2001-2010) Including CPUC Major Events	105.59	0.691
10-Year Average (2001-2010) Excluding CPUC Major Events	64.09	0.596

This Page Intentionally Left Blank

APPENDIX E DEMAND RESPONSE

Once changes are incorporated in the commercial utility agreements, the installation can autonomously take the following actions described in E-1 through E-3.

E-1 CONTROL OF DEMAND CHARGES.

There are multiple technologies that may be used for demand response, demand reduction, including load management, energy storage, and the use of renewable and non-renewable energy sources. Microgrid designers need to consider how the design of a microgrid could be used to reduce demand or load shifting.

E-2 POWER FACTOR CORRECTION.

Electrical systems include loads that are not purely resistive. More complex energy uses, such as motors, may cause phase misalignment of voltage and current. Apparent power does not equal true power. The misalignment, called Reactive Power, is measured in units of Volt- amp reactive. Utilities may charge the installation for a power factor that is less than their established rate structure (typically 0.90 leading or lagging). Microgrid designs may typically include control systems to correct power factor. The interconnecting utility will require the project to meet certain reactive power.

The interconnecting utility will require the project to meet certain reactive power requirements at the point of interconnection. Per FERC Order No. 827, a DG project must achieve a gross dynamic reactive power requirement of at least 0.95 leading through 0.95 lagging utilizing only the dynamic reactive power capability of the planned inverters and dynamic reactive power compensation equipment installed at the substation (e.g., STATCOM). This requirement should be assumed to be applicable over a voltage range of 0.95 pu through 1.05 pu at the high side of the substation. Check with utility for rate considerations for a 0.95 +/- 0.05 power factor.

E-3 CONTRACT REVISION.

In cooperation with the local utility and by negotiating a new contract, the installation can take additional actions. Within the United States, utilities are highly regulated and do not have unlimited freedom to negotiate rates. However, they frequently have published alternative rate schedules that provide discounts to customers willing to modify consumption, or can work with installations to develop site-specific tariffs. Other options for active demand management include on-call demand reduction, fixed reduction on preset schedule.

E-3.1 On-Call Demand Reduction.

On-call demand reduction is an agreement in which the utility customer agrees to reduce its load upon request and receives a reduced rate structure in return. The number of times per month for a reduction request is usually limited and the duration and amount of the reduction is limited. The microgrid generator resources (if permitted

for non-emergency use) may be used to offset the load, and control systems can be used to shed or manage the load.

E-3.2 Fixed Reduction on Preset Schedule.

This is an agreement in which the utility customer agrees to reduce its load by a fixed amount for a set time every day. The microgrid generator resources (if permitted for non-emergency use) may be used to offset the load, and control systems can be used to shed or manage the load.

Early in the microgrid design process, designers should coordinate with the local commercial power utility. Discussions and contract negotiations may extend for more than a year. The following issues and significant opportunities could arise, depending on discussions with the commercial utility provider(s).

APPENDIX F SUPPLEMENTARY ELECTRICAL FAULT PROTECTION AND GROUNDING

Early consideration should be given to the condition index of the existing electrical system. The Facility Condition Index and Condition Index/Condition Rating should be reviewed as part of the initial assessment. Validate compliance with UFC 3-550-01, NFPA 70, and IEEE C2 for requirements related to general system grounding. Specific engineering analysis is often necessary for short to ensure adequate provision of circuit protection and grounding of islanded networks predominantly energized by facility-scale distributed generation systems.

F-1 ELECTRICAL SYSTEM PROTECTION.

A challenge related to the microgrid design is electrical system protection. A pre-microgrid design includes protective devices that can identify faults and nearly instantaneously isolate the faulty circuit feeder to prevent damage to the remainder of the circuit and to the system as a whole. These devices often function by detecting high current levels associated with a fault. When connected to the grid, the utility system is capable of delivering the energy necessary to produce the high current. In microgrid mode, the distributed generators may not have capacity to provide enough energy to produce a sufficiently large current spike that could be detected by the protective equipment; the fault could go undetected and cause system damage. The onsite grid designs and protection equipment that were adequate before a microgrid was implemented may not offer adequate fault protection and may need to be revised. Analysis of the system protection design will include system simulation modeling prior to final design and construction. Protective device coordination studies will be performed as part of design and updated during construction.

F-2 SYNCHRONIZATION.

An additional challenge is synchronization. As soon as the primary grid fails, DERs begin to come online. Many of an installation's DERs will be standard emergency generators that are associated with specific loads. The DERs will operate autonomously, as they normally do, and will tend to be out of phase with each other. When the PCC is opened and the installation's connection to the grid is open, the DERs must synchronize before forming a microgrid. DERs must be "in phase" as they are connected (this is also true of the renewable resources that are added to the microgrid). A reference frequency is selected from among the DERs and all other DERs synchronize to the reference. The synchronization process repeats when the grid comes back online and the microgrid prepares to reconnect at the PCC. In this case, however, the microgrid DERs (in unison) use the utility frequency as their reference and synchronize to the utility.

Figure F-1 Interconnection and Protection on Transformer¹

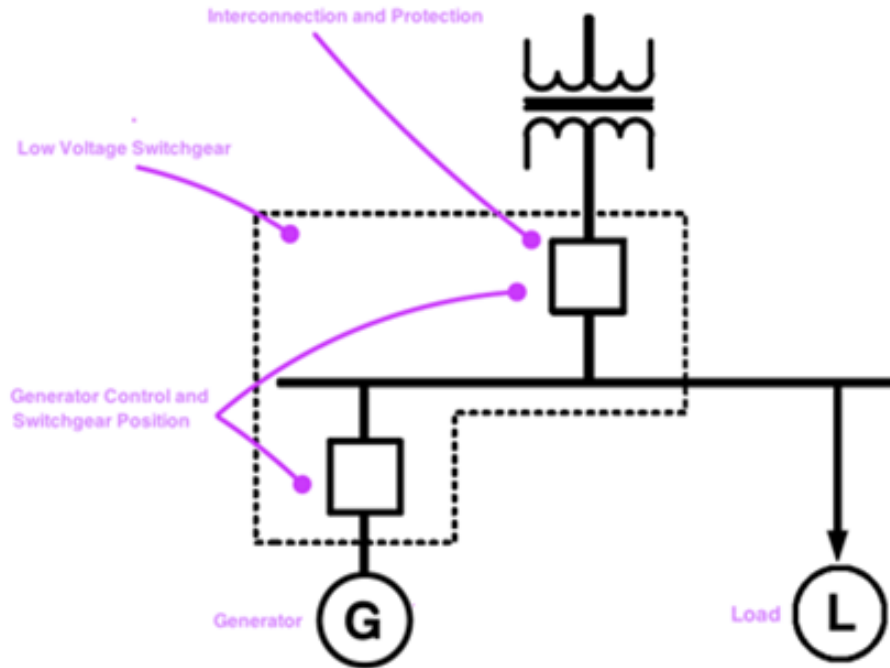

¹ US Army Corps of Engineers, Energy Research and Development Center, Energy Branch, 2022

APPENDIX G GLOSSARY

G-1 ACRONYMS.

AFCEC	Air Force Civil Engineer Center
AFCEC/CO	AFCEC/Operations Directorate
AFCEC/CN	AFCEC/Energy Directorate
AMI	Advanced meter infrastructure
AO	Approving Official
ATO	Cybersecurity Authorization to Operate
ATS	Automatic transfer switch
BESS	Battery energy storage system
BIA	Bilateral Infrastructure Agreement
CCR	Critical Change Request
CIO	Command Information Office
CONOPS	Continuity of operations
COTS	Commercial-off-the-shelf
DA	Department of the Army
DER	Distributed energy resource
DoD	Department of Defense
DOE	Department of Energy
DSG	Distributed System Generation
EPSS	Emergency power supply systems
ERCIP	Energy Resilience and Conservation Investment Program
ESPC	Energy Savings Performance Contract
FAA	Federal Aviation Administration
FAR	Federal Acquisition Regulation

FESS	Flywheel Energy Storage System
High-VAR	High-Voltage Volt Ampere Reactive
HMI	Human machine interface
HNFA	Host Nation Funded Construction Agreements
HQUSACE	Headquarters, US Army Corps of Engineers
ICS	Industrial control system
IGSA	Intergovernmental Service Agreement
IP	Internet protocol address
IT	Information Technology
MILCON	Military construction
MTR	Military Training Route
NAVFAC	Naval Facilities Engineering Systems Command
NEPA	National Environmental Policy Act
NIPR	Non-classified Internet Protocol Router Network
NIST	National Institute of Standard and Technology
NPS	Naval Post Graduate School
NRECA	National Rural Electric Cooperative Association
OSD	Office of the Secretary of Defense
PCC	Point of common coupling
PPA	Power Purchase Agreement
PV	Photo Voltaic
PW/PWO	Public Works/Public Works Officer
RE	Renewable Energy
\1\ RICE	Reciprocating Internal Combustion Engine /1/
RMF	Risk Management Framework

SCR	Short Circuit Ratio
SOC	State of Charge
SOFA	Status of Forces Agreement
SAIDI	System Average Interruption Duration Index
SAIFI	System Average Interruption Frequency Index
SIPR	Secret Internet Protocol Router Network
UCS	Utility control systems
UPS	Uninterruptible power supply
UESC	Utility Energy Service Contract
UFC	Unified Facilities Criteria
UMCS	Utility Monitoring Control System
UP	Utility privatization
VA	Volt / Amp
VPP	Voluntary Protection Program

G-2 DEFINITION OF TERMS.

Defense-in-depth: Information security strategy integrating people, technology, and operations capabilities to establish variable barriers across multiple layers and missions of the organization. (https://csrc.nist.gov/glossary/term/defense_in_depth).

This Page Intentionally Left Blank

APPENDIX H REFERENCES

H-1 GOVERNMENT STANDARDS

FEDERAL

10 U.S.C. 2911, *Energy Performance Goals and Master Plan for the Department of Defense*

EO 14057, *Catalyzing Clean Energy Industries and Jobs through Federal Sustainability*

DEPARTMENT OF DEFENSE

<https://www.wbdg.org/ffc/dod/unified-facilities-criteria-ufc>

UFC 1-200-01, *DoD Building Code*

UFC 3-410-02, *Direct Digital Control for HVAC and Other Building Control Systems*

UFC 3-440-01, *Facility-Scale Renewable Energy Systems*

UFC 3-470-01, *Utility Monitoring and Control System (UMCS) Front End and Integration*

UFC 3-501-01, *Electrical Engineering*

UFC 3-540-01, *Engine-Driven Generator Systems for Prime and Standby Power Applications*

UFC 3-540-08, *Utility-Scale Renewable Energy Systems*

UFC 3-550-01, *Exterior Electrical Power Distribution*

UFC 3-600-01, *Fire Protection Engineering for Facilities*

UFC 3-701-01, *DoD Facility Pricing Guide*

UFC 3-730-01, *Programming Cost Estimates for Military Construction*

UFC 3-740-05, *Construction Cost Estimating*

UFC 4-010-06, *Cybersecurity of Facility-Related Control Systems*

DoDD 3020.26, *Department of Defense Continuity Program*

DoDD 4270.5, *Military Construction*
(<http://www.dtic.mil/whs/directives/corres/html/42705.htm>)

DoDD 4715.21, *Climate Change Adaptation and Resilience*

DoDI 4170.11, *Installation Energy Instruction*

ERRE Program, *DoD Energy Resilience Readiness Exercise*

Federal Energy Regulatory Commission, FERC Order No. 827, *Reactive Power Requirements for Non-Synchronous Generation*

Mission Resilience and Off-Grid Endurance

DEPARTMENT OF THE AIR FORCE

AFMAN 32-1065, *Grounding Systems*, www.e-publishing.af.mil

STATE

Office of Under Secretary of Defense, *Metrics and Standards for Energy Resilience at Military Installations*, May 20, 2021

California Public Utilities Commission, *Rule 21 Interconnection*
<https://www.cpuc.ca.gov/industries-and-topics/electrical-energy/infrastructure/rule-21-interconnection>

Southern California Edison (SCE) [Microgrids for Developers \(sce.com\)](http://www.sce.com)

H-2 NON-GOVERNMENT STANDARDS

INSTITUTE OF ELECTRICAL AND ELECTRONICS ENGINEERS (IEEE)

IEEE C2, *National Electrical Safety Code*

IEEE 1366, *Guide for Electric Power Distribution Reliability Indices*

IEEE 1547, *Interconnection and Interoperability of Distributed Energy Resources with Associated Electric Power Systems Interfaces*

IEEE 1826, *Power Electronics Open System Interfaces in Zonal Electrical Distribution Systems Rated Above 100 kW*

IEEE 2030.8, *Standard for Testing Microgrid Controllers*

NATIONAL FIRE PROTECTION ASSOCIATION (NFPA)

NFPA 70E, *Electrical Workplace Safety*

NFPA 110, *Standard for Emergency and Standby Power Systems*

UNDERWRITERS LABORATORIES (UL)

UL 1741, *Safety Inverters, Converters, Controllers and Interconnection System Equipment for Use with Distributed Energy Resources*

UL, *Energy Storage System (ESS) Requirements*

H-3 OTHER RESOURCES

A review of microgrid development in the United States – A decade of progress on policies, demonstrations, controls, and software tools, Wei Feng, Ming Jin, Xu Liu, Yi Bao, Chris Marnay, Cheng Yao, Jiancheng Yu, Applied Energy, Volume 228, 2018, Pages 1656-1668

Assessment of Existing Capabilities and Future Needs for Designing Networked Microgrids, Shamina Hossain-McKenzie, Matthew J. Reno, John Eddy, Kevin P. Schneider, SAND2019- 2436, February 2019

Microgrid Analysis Tools Summary, National Renewable Energy Laboratory, <https://www.nrel.gov/docs/fy18osti/70578.pdf>