

UNIFIED FACILITIES CRITERIA (UFC)

DIRECT DIGITAL CONTROL FOR HVAC AND OTHER BUILDING CONTROL SYSTEMS



APPROVED FOR PUBLIC RELEASE; DISTRIBUTION UNLIMITED

UNIFIED FACILITIES CRITERIA (UFC)

DIRECT DIGITAL CONTROL FOR HVAC AND OTHER BUILDING CONTROL SYSTEMS

Any copyrighted material included in this UFC is identified at its point of use. Use of the copyrighted material apart from this UFC must have the permission of the copyright holder.

Indicate the preparing activity beside the Service responsible for preparing the document.

U.S. ARMY CORPS OF ENGINEERS \1\ (Preparing Activity) /1/

NAVAL FACILITIES ENGINEERING COMMAND \1\ /1/

AIR FORCE CIVIL ENGINEER CENTER

Record of Changes (changes are indicated by \1\ ... /1/)

Change No.	Date	Location
1	2 March 2020	<u>Changed Preparing Activity from Navy to Army. Added paragraph 2-4 USE OF PROPRIETARY NETWORKS, to accommodate new requirements for an exception to the use of open protocols within specific system types when certain criteria are met.</u>
2	1 April 2021	<u>Changed "UFC 3-401-01" to UFC 3-470-01" in paragraphs 1-2.1.3 and 1-3.2.3. Changed "APPENDIX A" to "APPENDIX D" in paragraph 5-4.2. Deleted first sentence of paragraph 6-6.1.</u>

This UFC supersedes UFC 3-410-02, dated 5 2012.

FOREWORD

The Unified Facilities Criteria (UFC) system is prescribed by MIL-STD 3007 and provides planning, design, construction, sustainment, restoration, and modernization criteria, and applies to the Military Departments, the Defense Agencies, and the DoD Field Activities in accordance with [USD \(AT&L\) Memorandum](#) dated 29 May 2002. UFC will be used for all DoD projects and work for other customers where appropriate. All construction outside of the United States is also governed by Status of Forces Agreements (SOFA), Host Nation Funded Construction Agreements (HNFA), and in some instances, Bilateral Infrastructure Agreements (BIA.) Therefore, the acquisition team must ensure compliance with the most stringent of the UFC, the SOFA, the HNFA, and the BIA, as applicable.

UFC are living documents and will be periodically reviewed, updated, and made available to users as part of the Services' responsibility for providing technical criteria for military construction. Headquarters, U.S. Army Corps of Engineers (HQUSACE), Naval Facilities Engineering Command (NAVFAC), and Air Force Civil Engineer Center (AFCEC) are responsible for administration of the UFC system. Defense agencies should contact the preparing service for document interpretation and improvements. Technical content of UFC is the responsibility of the cognizant DoD working group. Recommended changes with supporting rationale should be sent to the respective service proponent office by the following electronic form: [Criteria Change Request](#). The form is also accessible from the Internet sites listed below.

UFC are effective upon issuance and are distributed only in electronic media from the following source:

- Whole Building Design Guide web site <http://dod.wbdg.org/>.

Refer to UFC 1-200-01, *DoD Building Code (General Building Requirements)*, for implementation of new issuances on projects.

AUTHORIZED BY:



LARRY D. McCALLISTER, P.E., PhD, PMP, SES
Chief, Engineering and Construction
Directorate of Civil Works
U.S. Army Corps of Engineers



JOSEPH E. GOTT, P.E.
Chief Engineer
Naval Facilities Engineering Command



EDWIN H. OSHIBA, SES, DAF
Deputy Director of Civil Engineers
DCS/Logistics, Engineering & Force Protection



MICHAEL McANDREW
Deputy Assistant Secretary of Defense
(Facility Investment & Management)
Office of the Assistant Secretary of Defense
(Energy, Installations, and Environment)

**UNIFIED FACILITIES CRITERIA (UFC)
REVISION SUMMARY SHEET**

Document: UFC 3-410-02 *Direct Digital Control for HVAC and Building Control Systems, formerly LonWorks® Direct Digital Control for HVAC and Other Local Building Systems*

Superseding: None

Description: Design guidance and requirements for Open Direct Digital Control Systems. The guidance is particularly detailed due to the complex and definitive requirements required for the design of a digital control system and for the procurement of an Open system that supports integration into a multi-vendor system.

Reasons for Document: Initial version of this UFC covered LNS-Based LonWorks only. Extensive revisions were required to accommodate BACnet and the Niagara Framework.

Impact: There are negligible cost impacts; however, these benefits should be realized:

- The ability to procure systems competitively that can be integrated into a single supervisory system rather than requiring the procurement of several supervisory systems.
- Competitive procurement of control systems will result in cost savings. . Describe the impact. This should describe impact on design cost, initial cost, energy savings, or life cycle costs.

Unification Issues: None

TABLE OF CONTENTS

CHAPTER 1 INTRODUCTION	1
1-1 BACKGROUND	1
1-1.1 Open system benefits and capabilities.	1
1-1.2 References to UFGS 23 09 23.XX.	2
1-2 OPEN SYSTEM TECHNOLOGIES	2
1-2.2 Control system types	3
1-2.3 Open system design complexity	3
1-3 PURPOSE AND SCOPE	4
1-3.1 Purpose	4
1-3.2 Scope.....	4
1-4 APPLICABILITY	5
1-5 GENERAL BUILDING REQUIREMENTS	5
1-6 REFERENCES	5
1-7 GLOSSARY	5
CHAPTER 2 TECHNICAL REQUIREMENTS	7
2-1 USE OF UFGS 23 09 XX SERIES OF SPECIFICATIONS	7
2-2 USE OF UFGS 23 09 23.XX	7
2-3 TAILORING AND DESIGNER OPTIONS IN UFGS 23 09 23.XX	7
2-4 \1\ USE OF PROPRIETARY NETWORKS. /1/	7
2-4.1 \1\ Proprietary Networks for Simple Split Systems. /1/	7
2-4.2 \1\ Proprietary Networks for Multi-Split Systems (Including Variable Refrigerant Flow (VRF) Systems). /1/	8
2-4.3 \1\ Proprietary Networks for Chiller and Boiler Plants. /1/	8
2-4.4 \1\ All Other Systems. /1/	9
CHAPTER 3 DESIGN	11
3-1 INTRODUCTION	11
3-2 BASEWIDE UMCS ARCHITECTURE	11
3-3 LONWORKS BCN ARCHITECTURE	12
3-3.1 General.....	12
3-3.2 CEA 709 Media selection.	14
3-4 BACNET BCN ARCHITECTURE	14

3-4.1	Device and network addressing.	15
3-4.2	Media selection.	16
3-5	NIAGARA FRAMEWORK NETWORK.	17
3-5.1	Niagara Framework and LonWorks.	17
3-5.2	Niagara Framework and BACnet.	18
3-6	CONNECTION TO A UMCS.	18
3-7	NETWORK HARDWARE.	18
3-8	NETWORK DESIGN AND LAYOUT.	19
3-8.1	Data transmission methods.	19
3-8.2	Data integrity.	19
3-8.3	Number of controllers per system or sequence.	20
3-9	CYBERSECURITY.	20
CHAPTER 4 DIRECT DIGITAL CONTROL HARDWARE AND CONTROL DEVICES 21		
4-1	INTRODUCTION.	21
4-2	LONWORKS REQUIREMENTS.	21
4-2.1	General.	21
4-2.2	Application specific controller.	22
4-2.3	Application generic controller.	22
4-2.4	General purpose programmable controller.	22
4-3	BACNET REQUIREMENTS.	22
4-3.1	General.	22
4-3.2	Scheduling.	23
4-3.3	Alarm generation.	23
4-3.4	Trending.	24
4-3.5	Engineering units.	24
4-4	NIAGARA FRAMEWORK REQUIREMENTS.	24
4-4.1	General.	24
4-4.2	Niagara Framework and LonWorks (UFGS 23 09.01).	24
4-4.3	Niagara Framework and BACnet (UFGS 23 09.02).	24
4-5	OTHER ISSUES.	25
4-5.1	Expansion modules and tethered hardware.	25
4-5.2	Building management interface.	25

4-5.3	Local Display Panel.	25
4-5.4	Networked sensors and actuators.	26
4-5.5	Hand-Off-Auto (H-O-A) Switches.	26
CHAPTER 5 CONTROL SYSTEM DRAWINGS.....		27
5-1	CONTROL SYSTEM DRAWINGS OVERVIEW.	27
5-2	SAMPLE DRAWINGS.....	27
5-2.1	Brackets in sample drawings.....	27
5-3	UNIQUE IDENTIFIERS.....	28
5-4	POINTS SCHEDULE.....	28
5-4.1	Overview.....	28
5-4.2	Responsibilities.	28
5-4.3	UMCS content shown on UFGS 25 10 10 points schedules.	28
5-4.4	Points Schedule Description and Instructions.	29
5-5	CONTROL SYSTEM SCHEMATIC.....	29
5-5.1	Loops and devices.	29
5-5.2	Sequencing diagrams.	30
5-5.3	Designer notes.	30
5-6	LADDER DIAGRAM.....	30
5-7	CONTROL LOGIC DIAGRAM.....	31
5-8	SEQUENCE OF OPERATION.....	31
5-9	THERMOSTAT AND OCCUPANCY SENSOR SCHEDULE.....	32
5-9.1	Thermostats.	32
5-9.2	Occupancy sensors.	32
5-9.3	Schedule entries.	33
5-10	OCCUPANCY SCHEDULE.....	34
5-10.1	System default schedule.	34
5-10.2	Supervisory monitoring and control schedule.	34
5-10.3	Number of occupancy sensors to put AHU in occupied mode.	34
CHAPTER 6 BUILDING CONTROL SYSTEM DESIGN AND IMPLEMENTATION		35
6-1	INTRODUCTION.....	35
6-2	PLANNING.....	35
6-3	CHOICE OF SPECIFICATION AND PROTOCOL.....	35

6-4	INTEGRATION TO UMCS.....	35
6-5	PROCUREMENT CONSIDERATIONS.....	36
6-6	DDC DESIGN.....	36
6-6.1	General.....	36
6-7	DRAWING PACKAGE.....	36
APPENDIX A REFERENCES.....		37
APPENDIX B BEST PRACTICES.....		39
APPENDIX C GLOSSARY.....		41
C-1	ACRONYMS.....	41
C-2	DEFINITION OF TERMS.....	42
C-2.1	Field Control System (FCS) and Field Control Network (FCN).....	42
C-2.2	Field Point of Connection (FPOC).....	42
C-2.3	Industrial Control System (ICS).....	43
C-2.4	Utility Monitoring and Control System (UMCS).....	43
C-2.5	Utility Monitoring and Control System (UMCS) Front End.....	43
C-2.6	Utility Monitoring and Control System (UMCS) IP Network.....	43
C-3	TERMS SPECIFICALLY NOT USED BY THIS UFC.....	43
C-4	OTHER TERMINOLOGY.....	43
APPENDIX D POINTS SCHEDULE I INSTRUCTIONS.....		45
D-1	USE OF BRACKETS IN THE POINTS SCHEDULE.....	45
D-2	POINTS SCHEDULE DESCRIPTION AND INSTRUCTIONS.....	45
D-2.1	General Columns.....	46
D-2.2	Protocol-Specific Columns.....	53
D-2.3	Configuration Information.....	58
D-2.4	Point Schedule Application Notes.....	59
APPENDIX E POINT NAMING CONVENTION.....		61
E-1	POINT SCHEDULE APPLICATION NOTES.....	61
E-2	DEVICE DESCRIPTORS.....	61
E-3	TYPICAL VARIABLES OR CONTROLLED DEVICES.....	64
E-4	TYPICAL MODIFIERS.....	65
E-5	EXAMPLE POINT NAMES.....	66
E-6	OTHER ABBREVIATIONS.....	68

APPENDIX F Control Logic Diagram (CLD) Overview	72
F-1 INTRODUCTION.....	72
F-2 FUNCTIONAL BLOCKS USED IN CONTROL LOGIC DIAGRAMS.....	72
F-2.1 Signal.	72
F-2.2 Actuator Output.	72
F-2.3 Sensor Input.	73
F-2.4 Hand-Off-Auto (H-O-A) Switch.....	73
F-2.5 Constant Value.....	73
F-2.6 Signal I/O.	73
F-2.7 Logical AND.	74
F-2.8 Logical NOT.	74
F-2.9 Logical OR.....	74
F-2.10 On Delay Timer.	74
F-2.11 Switch.	75
F-2.12 Comparator with Deadband.	75
F-2.13 Reset Schedule.....	76
F-2.14 Math Function.....	76
F-2.15 PID Loop with Enable.	77
F-2.16 IF Block.....	77
F-2.17 Set/Reset Latch.....	77

FIGURES

Figure 3-1 UMCS Architecture	12
Figure 3-2 LonWorks Building Network Architecture	13
Figure 3-3 BACnet Building Network Architecture	15
Figure 5-1 Sample Ladder Diagram	31
Figure 5-2 Thermostat and Occupancy Sensor Schedule.	32

TABLES

This Page Intentionally Left Blank

CHAPTER 1 INTRODUCTION

1-1 BACKGROUND.

Designers, installers, and operations and maintenance (O&M) staff have struggled with the complexities and incompatibilities of multi-vendor building automation direct digital control (DDC) systems almost since they were introduced in the 1980's. DDC systems are routinely designed and procured on a building-by-building or sub-system by sub-system basis, most notably for heating, ventilating, and air-conditioning (HVAC) systems. In the absence of specifications and criteria for Open systems, Government procurement rules which require competitive bidding make it extremely difficult if not impossible to procure new DDC systems that are compatible with existing ones and that are also compatible with a basewide or campus-wide supervisory system.

In the absence of sole-source procurement, new but incompatible DDC systems result at best in inefficiencies and at worst in complex and non-functioning systems. This is a problem with system-to-system data sharing and is a problem where multiple individual systems need to communicate with a supervisory monitoring and control (front-end) system such as a Utility Monitoring and Control System (UMCS) specified by UFGS 25 10 10. This inability to interoperate is a result of Closed systems due to vendor-specific proprietary elements. In contrast, Open DDC systems are now available. An Open DDC system is characterized by the ability for any qualified entity to readily modify, operate, upgrade, and perform retrofits on the DDC system. An Open system:

- Permits multiple devices from multiple vendors to readily exchange information.
- Provides the capability to easily replace any device with another device procured from multiple sources.
- May have proprietary components within devices, but these proprietary components must be a small percentage of the overall device.
- May have fees associated with use of certain components.

In short, an Open system is one (integrated, multi-vendor) system where there is no future dependence on any one Contractor or controls vendor.

1-1.1 Open system benefits and capabilities.

Open communications and data sharing between multi-vendor systems and with a third party supervisory system is necessary to achieve effective system operation. Some of the benefits and capabilities of Open multi-vendor DDC systems include:

- Competitive procurement, most notably at the building and sub-system level.
- An operator workstation/user interface that provides for the same look and feel for monitoring and control regardless of which vendor's DDC system or sub-

system an operator is viewing. As a result, system operators need only become proficient with one user interface.

- An operator workstation/user interface (software) that provides for management of base-wide system operations such as: remote alarm reporting, remote scheduling (on/off control), remote set point override, data logging and reports, energy management including load shedding, utilities monitoring/measurement for the purpose of monitoring energy performance contracts, and initial diagnosis of service calls. The ability to monitor multiple vendor's systems from a single Operator Workstation/User Interface (OWS/UI) with the same look and feel across all vendor's systems. As a result, through a single user interface, system operators and managers are afforded the means to efficiently and effectively manage base-wide operations.
- A whole-building approach to systems integration. This includes the efficient inter-connection of HVAC control sub-systems. For example, terminal unit equipment, such as VAV boxes can be readily interfaced to the servicing air handler to provide a call for cooling. In addition, the whole-building approach provides the capability for integrating non-HVAC sub-systems such as fire and security
- (For a LonWorks system) groundwork for establishment of a non-proprietary and openly accessible 'point-database' in support of communications-network management requirements.

1-1.2 References to UFGS 23 09 23.XX.

This UFC is intended to be used with UFGS 23 09 00 (Instrumentation and Control for HVAC), UFGS 23 09 23.01 (LonWorks® Direct Digital Control for HVAC and Other Building Systems), and UFGS 23 09 23.02 (BACnet Direct Digital Control for HVAC and Other Building Systems). This document will often use "UFGS 23 09 23.XX" when the intent is to refer to both the LonWorks and BACnet UFGS.

1-2 OPEN SYSTEM TECHNOLOGIES.

The Open systems approach described in this UFC is based on several possible technologies: BACnet, LONWORKS, or Niagara Framework.

1-2.1.1 BACnet.

The term "BACnet" is used in this UFC as the shorthand reference to the ANSI/ASHRAE Standard 135, specifically referring to the communications protocol specified there-in. The term "BACnet" is also used in this UFC to loosely describe a collection of technologies, including hardware, and software, vendors and installers relating to or based on the ASHRAE Standard 135 communications protocol. While every attempt has been made to distinguish which meaning is intended, in some cases the reader must make the determination from context

1-2.1.2 LONWORKS®

ANSI/CEA standard 709.1-C communications protocol (sometimes referred to as LonTalk®) and on LONWORKS® Network Services (LNS®) network operating system. The standard protocol supports Open communications while LNS supports Open network management. 'CEA 709.1' is used in this UFC as the shorthand reference to the ANSI/CEA standard 709.1-C communications protocol. In this UFC the term LONWORKS® is used to loosely describe a collection of technologies (including hardware, and software), vendors and installers relating to or based on the CEA 709.1 communications protocol

1-2.1.3 Niagara Framework.

The Niagara Framework is a protocol and set of technologies developed and owned by Tridium Inc. which is licensed to multiple vendors. Different vendors provide this system under different product names, but the overall term used by Tridium is “Niagara”. The Niagara Framework may be used in conjunction with either the BACnet or LonWorks option to design a system using BACnet or LonWorks that also can interoperate with a Niagara Framework front end installed in accordance with UFGS 25 10 10 and/or ~~12~~ UFC 3-470-01, Utility Monitoring And Control System (UMCS) Front End and Integration ~~12~~. Note that use of Niagara Framework will override/trump some design options that would normally be used in a BACnet or LonWorks system.

1-2.2 Control system types

The combination of technologies result in 4 possible building control system types:

- A BACnet building using the BACnet standard
- A BACnet building using both the BACnet standard and the Niagara Framework
- A LonWorks building using CEA 709.1 and LNS
- A LonWorks building using both CEA 709.1 and the Niagara Framework

1-2.3 Open system design complexity

The design of an Open system is not simple. It requires attention to a great deal of detail. This UFC, the specifications, and accompanying drawings were developed to minimize the time and effort required on the part of the designer.

The level of detail contained in the guide specification and this UFC is necessary because of the variety of approaches that can be used to implement BACnet, or CEA 709.1-C, or Niagara Framework where, in the absence of this detail, would very likely result in incompatible systems.

1-3 PURPOSE AND SCOPE.

1-3.1 Purpose

The design concept described in this UFC provides definitive guidance intended to streamline DDC system design and installation leading to maintainable, interoperable, extensible, and non-proprietary control systems. This UFC also contains minimal project requirements. The purpose of this UFC is two-fold, to provide for commonality and compatibility of control systems:

- **Commonality.** Describes a definitive methodology for the design of building-level control systems and strategies (primarily for HVAC) where the intent is to achieve at least a degree of commonality in systems designed and procured through different channels. Common sequences of operation are specified in UFGS 23 09 93.
- **Compatibility.** Describes a definitive methodology to obtain multi-vendor systems that can communicate and interoperate with each other and with a supervisory monitoring and control system such as a basewide UMCS through the use of an Open communications protocol.

1-3.2 Scope.

This UFC describes the design of HVAC control systems and the associated building control network that can interface to a UMCS in an Open and non-proprietary manner.

1-3.2.1 HVAC control sequences and instrumentation.

These topics are covered in UFGS 23 09 13, UFGS 23 09 93.

1-3.2.2 Building controllers and control network.

This UFC describes designer selections for DDC hardware and software as well as the Building Control Network (BCN) communications including data exchange, architecture, and cabling.

1-3.2.3 UMCS interface.

The DDC system can function as a stand-alone system with reduced functionality (limited user interface, no trending etc.) but is intended to be integrated into a UMCS in accordance with the UMCS guidance (UFC 3-401-01 and UFGS 25 10 10) to provide for remote supervisory monitoring and control of the DDC system. This UFC (3-410-02) and UFGS 23 09 23.XX helps to ensure that the building-level control system is capable of being interconnected with a UMCS installed in accordance with UFGS 25 10 10 and/or ~~12~~ UFC 3-470-01, Utility Monitoring And Control System (UMCS) Front End and Integration ~~12~~. Even in the absence of a UMCS, this UFC describes the methodology for designer selection and specification of data exchange parameters including requirements that will facilitate subsequent non-proprietary UMCS interface.

1-3.2.4 Other systems.

Although not directly addressed or specified in the UFC or UFGS the methodology, approach, and many of the requirements defined in this UFC and UFGS 23 09 23.XX can be used in the design of other (non-HVAC) Open DDC systems such as water and sanitary sewer systems, electrical systems, lighting, and other utility systems and equipment.

1-4 APPLICABILITY.

This UFC is applicable to all HVAC control system design, both for new construction and renovation. This UFC and the guide specifications may also be applied to other non-HVAC building control when those systems use LonWorks or BACnet.

1-5 GENERAL BUILDING REQUIREMENTS.

Comply with UFC 1-200-01, DoD Building Code (General Building Requirements). UFC 1-200-01 provides applicability of model building codes and government unique criteria for typical design disciplines and building systems, as well as for accessibility, antiterrorism, security, high performance and sustainability requirements, and safety. Use this UFC in addition to UFC 1-200-01 and the UFCs and government criteria referenced therein.

1-6 REFERENCES.

Appendix A contains a list of references used in this document. The publication date of the code or standard is not included in this document. Unless otherwise specified, the most recent edition of the referenced publication applies.

1-7 GLOSSARY.

Appendix C contains acronyms, abbreviations, and terms. In addition, UFGS 23 09 00 contains an extensive list of definitions.

This Page Intentionally Left Blank

CHAPTER 2 TECHNICAL REQUIREMENTS

2-1 USE OF UFGS 23 09 XX SERIES OF SPECIFICATIONS.

Unless specifically indicated in this UFC or with specific written permission from the authority having jurisdiction, the design of a building control system must use UFGS 23 09 00 and either UFGS 23 09 23.01 or UFGS 23 09 23.02 (as appropriate) without edits beyond the use of tailoring options and designer option.

2-2 USE OF UFGS 23 09 23.XX.

The implementation of a building control system requires highly specific and prescriptive specifications. UFGS 23 09 23.01 (for LonWorks based BCS) and UFGS 23 09 23.02 (for BACnet based BCS) incorporates these requirements, and makes use of SpecsIntact Tailoring Options and designer options (bracketed text with notes) to allow for project-specific editing.

Unless specifically indicated in this UFC or with specific written permission from the authority having jurisdiction, the design of a building control system must use either UFGS 23 09 23.01 or UFGS 23 09 23.02 (as appropriate) without edits beyond the use of tailoring options and designer options.

2-3 TAILORING AND DESIGNER OPTIONS IN UFGS 23 09 23.XX.

The use of tailoring options and designer options in either UFGS 23 09 23.01 or UFGS 23 09 23.02 must be in accordance with this UFC.

2-4 \1\ USE OF PROPRIETARY NETWORKS. /1/

\1\ The use of multiple devices communicating on a proprietary networks is allowed as an exception to the open protocol requirements of UFGS 23 09 23.01 or UFGS 23 09 23.02 only when the specific requirements in the following paragraphs are met. Note that internal communications within a single piece of packaged equipment (package unit) need not meet the open protocol requirements, but the packaged equipment must be provided with an interface meeting the open protocol requirements.

When including proprietary networks in a design as permitted in this UFC, the systems specifically permitted to use proprietary networks must be indicated in UFGS 23 09 00. /1/

2-4.1 \1\ Proprietary Networks for Simple Split Systems. /1/

\1\ A simple split (DX) system consisting of a single indoor unit and a single outdoor unit from the same manufacturer is always permitted to use a proprietary network between the two units provided that one unit has an open protocol interface meeting the requirements of the UFGS. Include a Points Schedule in the design package for the split system at the system interface. /1/

2-4.2 \1\ Proprietary Networks for Multi-Split Systems (Including Variable Refrigerant Flow (VRF) Systems). /1/

\1\ Multi-split (including variable refrigerant flow (VRF)) systems using proprietary networks connecting multiple units which operate together must meet the following requirements:

- A gateway must be provided between the proprietary network and the open protocol control system required by UFGS 23 09 23.01 or UFGS 23 09 23.02 to provide a functional interface between the two networks. The open protocol side of the gateway must meet the requirements of UFGS 23 09 23.01 or UFGS 23 09 23.02.
- A Point Schedule for the system must be included in the design package to define the functional interface of the system to the open protocol control system.
- All units must be products of a single manufacturer.
- The units must operate using a common sequence of operation which operates the units in a manner that requires operational parameters be shared between them. The units must use a factory provided program for the sequence of operation; this program may be field configurable but units must not be field programmed.
- The solution using the proprietary network must have a lower life-cycle cost than at least two (2) alternate solutions not using proprietary networks.
- The System Owner receiving the control system must approve of and accept the use of the system. When a System Owner does not accept a system using a proprietary network it must not be used regardless of other factors.
- For USACE projects, the Utility Monitoring and Control System Mandatory Center of Expertise (UMCS MCX) must review the design, life cycle cost analysis, and System Owner approval and concur prior to specifying a system using a proprietary network.

When allowing proprietary networks for multi-split systems, the life cycle cost analysis, System Owner approval, and UMCS-MCX concurrence (for USACE projects) must be included in the design documents. The systems specifically permitted to use proprietary networks must be indicated in the table provided in UFGS 23 09 00. /1/

2-4.3 \1\ Proprietary Networks for Chiller and Boiler Plants. /1/

\1\ Boilers or chillers using proprietary networks connecting multiple units which operate together must meet the following requirements:

- A gateway must be provided between the proprietary network and the open protocol control system required by UFGS 23 09 23.01 or UFGS 23 09 23.02 to provide a functional interface between the two networks. The open protocol side of the gateway must meet the requirements of UFGS 23 09 23.01 or UFGS 23 09 23.02.
- A Point Schedule for the system must be included in the design package to define the functional interface of the system to the open protocol control system.
- All units must be from the same manufacturer.
- All units must be co-located in the same room, and the network connecting them must be fully contained in that room.
- The units must operate using a common "plant" sequence of operation which stages the units in a manner that requires operational parameters be shared between them and which cannot be accomplished with a single lead-lag command from a third-party controller.
- The design must include specific model chiller and boilers. If the design is not specifying the exact equipment, do not include the exception as part of the design; UFGS 23 09 00 includes a mechanism by which the installing contractor can request the exception if needed. (In most cases, this means that this exception will apply primarily to design-build projects and not design-bid-build.)

When allowing proprietary networks for chiller or boiler plants, the design documents must include a statement that the system meets the necessary requirements for use of a proprietary networks and the systems specifically permitted to use proprietary networks must be included in the table provided in UFGS 23 09 00. /1/

2-4.4 \1\ All Other Systems. /1/

\1\ The specific exceptions defined in this UFC were determined as warranted based on implementation and maintenance considerations, and on industry capabilities to provide solutions meeting open systems requirements and apply only to the indicated systems. For all other systems, the use of multiple devices communicating on a proprietary networks requires a waiver from UFC requirements.

To suggest additional systems for consideration for establishing exception procedures, submit a Criteria Change Request (CCR) to this UFC. /1/

This Page Intentionally Left Blank

CHAPTER 3 DESIGN

3-1 INTRODUCTION.

This chapter describes building-level Open-communications control system architecture, device functionality, and control devices for HVAC and other building-level monitoring and control applications. The communications network and devices are based on one of:

- LonWorks® technology and CEA 709.1 communications protocol with LNS
- LonWorks and the Niagara Framework
- BACnet, ASHRAE-135
- BACnet and the Niagara Framework

This UFC will primarily focus on either the LonWorks or BACnet option, with supplemental material provided to cover the Niagara Framework variant. Design of an Open-communications building-level control system does not require an extensive familiarity with CEA 709.1 protocol, BACnet, or the Niagara Framework, but it is critical that the designer understand that these protocols can be implemented in a manner that is not Open and thus can lead to incompatible systems. Therefore, this chapter contains supplemental information to be used in conjunction with UFGS 23 09 23.XX.

3-2 BASEWIDE UMCS ARCHITECTURE.

As illustrated Figure 3-1, a basewide system consists of a UMCS (specified by UFGS 25 10 10) containing to one or more building-level DDC systems (specified by UFGS 23 09 00 and UFGS 23 09 23.XX). The network architecture consists of a basewide IP network and one or more building-level networks. DDC UFGS 23 09 23.XX refers to the building-level network as the Building Control Network (BCN). A field point of connection (FPOC) provides an interface between the basewide IP and BCN networks. Since the FPOC is the location where the contractor-installed Building Control Network (BCN) meets the basewide IP network, the location of the FPOC must be coordinated with the base IT/networking staff.

Figure 3-1 UMCS Architecture

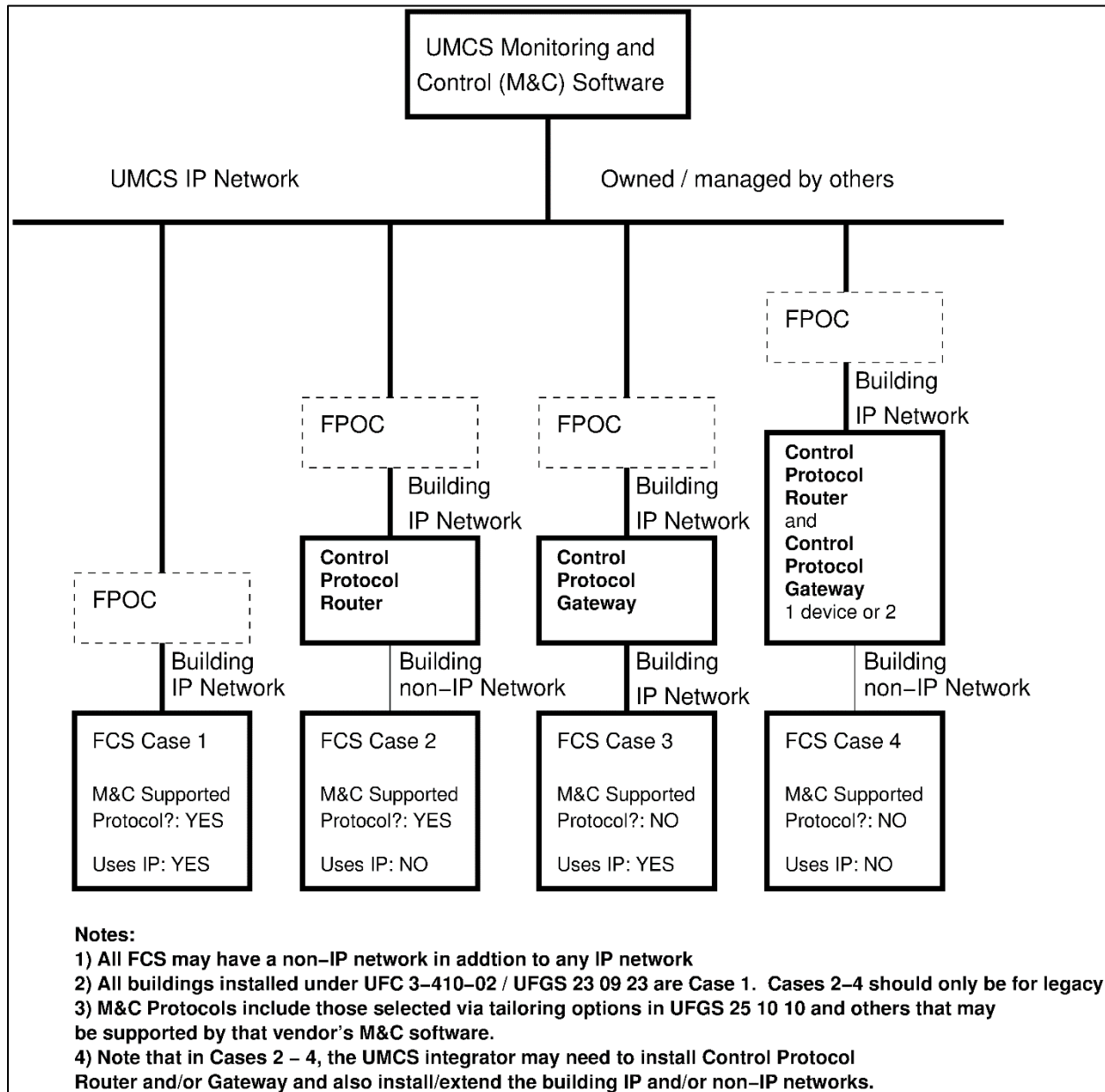

3-3 LONWORKS BCN ARCHITECTURE.

3-3.1 General.

As illustrated in Figure 3-2, a LonWorks (with or without Niagara Framework) BCN consists of an IP network with one or more (in the case of LonWorks with LNS) CEA 852 routers or (in the case of LonWorks with Niagara) Niagara Framework Supervisory Gateways. Beneath each CEA 852 router or Niagara Framework Supervisory Gateway is either TP/XF-1250 media or TP/FT-10 media (not all Niagara Framework Supervisory Gateways will necessarily have a network beneath them). TP/XF-1250 media functions

as a non-IP network backbone and will only have Lon-to-Lon routers connected to it. Each Lon-to-Lon router will, in turn, have TP/FT-10 media connected, with individual DDC Hardware connected to the individual TP/FT-10 networks.

TP/FT-10 media directly connected to a CEA 852 router or Niagara Framework Supervisory Gateway may have DDC Hardware connected to it, or it may be used as a non-IP network backbone (identical to the use of TP/XF-1250 media). When used as a non-IP network backbone it will only have Lon-to-Lon routers connected to it (with TP/FT-10 networks and DDC Hardware connected to the individual Lon-to-Lon routers). The LNS-based LonWorks architecture produces a logically flat network in the building where each node can communicate directly with any other node without the intervention of another controller.

Figure 3-2 LonWorks Building Network Architecture

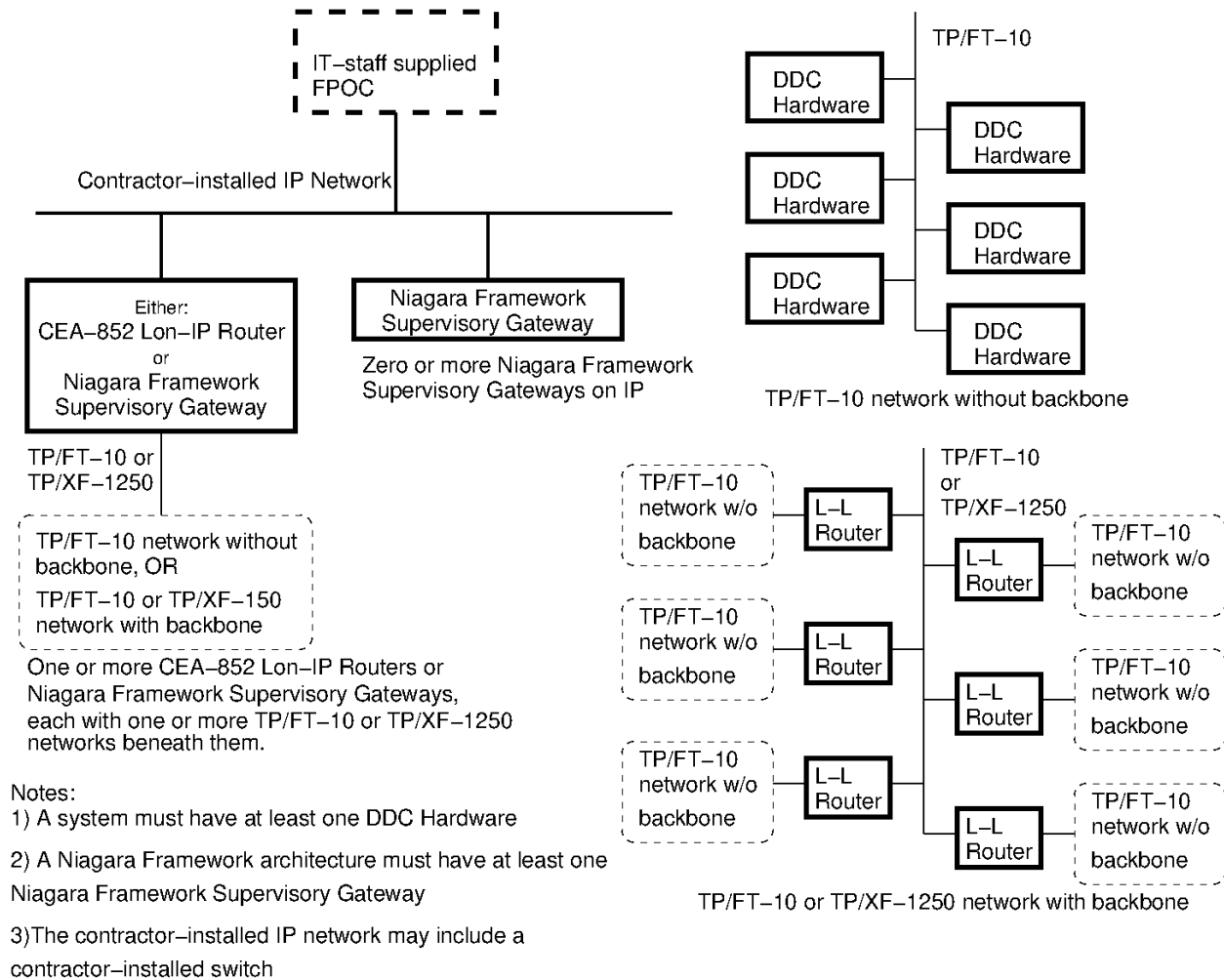

3-3.2 CEA 709 Media selection.

UFGS 23 09 23.01 specifies the use of one of: IP, TP/XF-1250, or TP/FT-10 media; each has advantages and disadvantages:

- IP is necessary because the UMCS uses IP, so at some point the network needs to connect to IP. For a smaller building, this may as simple as a single IP port on a CEA 852 router or Niagara Framework Supervisory Gateway. Larger buildings will likely have multiple devices on IP and a contractor-installed IP network. IP also has by far the greatest bandwidth of the media types. IP does have the downside of having the most IA (Information Assurance) issues. Future management of the IP network will vary from service to service and possibly even from site to site, but all IP networks will be required to meet some level of Information Assurance (IA) requirements.
- TP/XF-1250 communicates at 1250 kbps, which is considerably faster than TP/FT-10, but not as fast as IP. TP/XF-1250 is not part of the CEA 709 standard, but it is a de-facto standard for a high-speed Lon media. There are very few DDC Hardware devices using TP/XF-1250, so its use is limited to that of a backbone media. TP/XF-1250 must be installed in a doubly-terminated bus configuration.
- TP/FT-10 communicates at 78 kbps, which is the slowest of the 3 but still sufficiently fast to allow its use as the main media type in fairly large installations. It is covered by CEA 709 and is universally supported; almost all devices support TP/FT-10 and in these specifications it is the only media that can be connected to DDC Hardware (other than Niagara Framework Supervisory Gateways). TP/FT-10 must be installed in a doubly-terminated bus configuration

Use of other media types may limit future competition by giving an advantage to the limited number of vendors whose products support the non-standard media. Therefore use of alternative media is prohibited by the guide specifications. There may be some situations where a different CEA 709 media is needed – such the use of Power Line for retrofits where it is impossible to run new media or fiber optic for inter-building runs where electrical isolation is required. Do not specify or permit alternate media without written authorization from the AHJ.

3-4 BACNET BCN ARCHITECTURE.

BACnet uses the term internetwork to refer to the entire connected BACnet system, consisting of one or more interconnected individual BACnet networks. A particular site may have multiple disconnected internetworks; each would be a separate BACnet system.

As illustrated in Figure 3-3, a BACnet (with or without Niagara Framework) BCN consists of an IP network with a mixture of DDC Hardware (including, in the case of the Niagara Framework, Niagara Framework Supervisory Gateways) and BACnet MS/TP –

to- BACnet IP routers (which may be furnished as part of DDC Hardware). Each MS/TP –to- IP router or Niagara Framework Supervisory Gateway may have MS/TP networks beneath it, with DDC Hardware on the individual MS/TP networks. Each project will have a single Field Point of Connection (FPOC) which provides an interface between the basewide IP network and the BCN network installed by that project.

Figure 3-3 BACnet Building Network Architecture

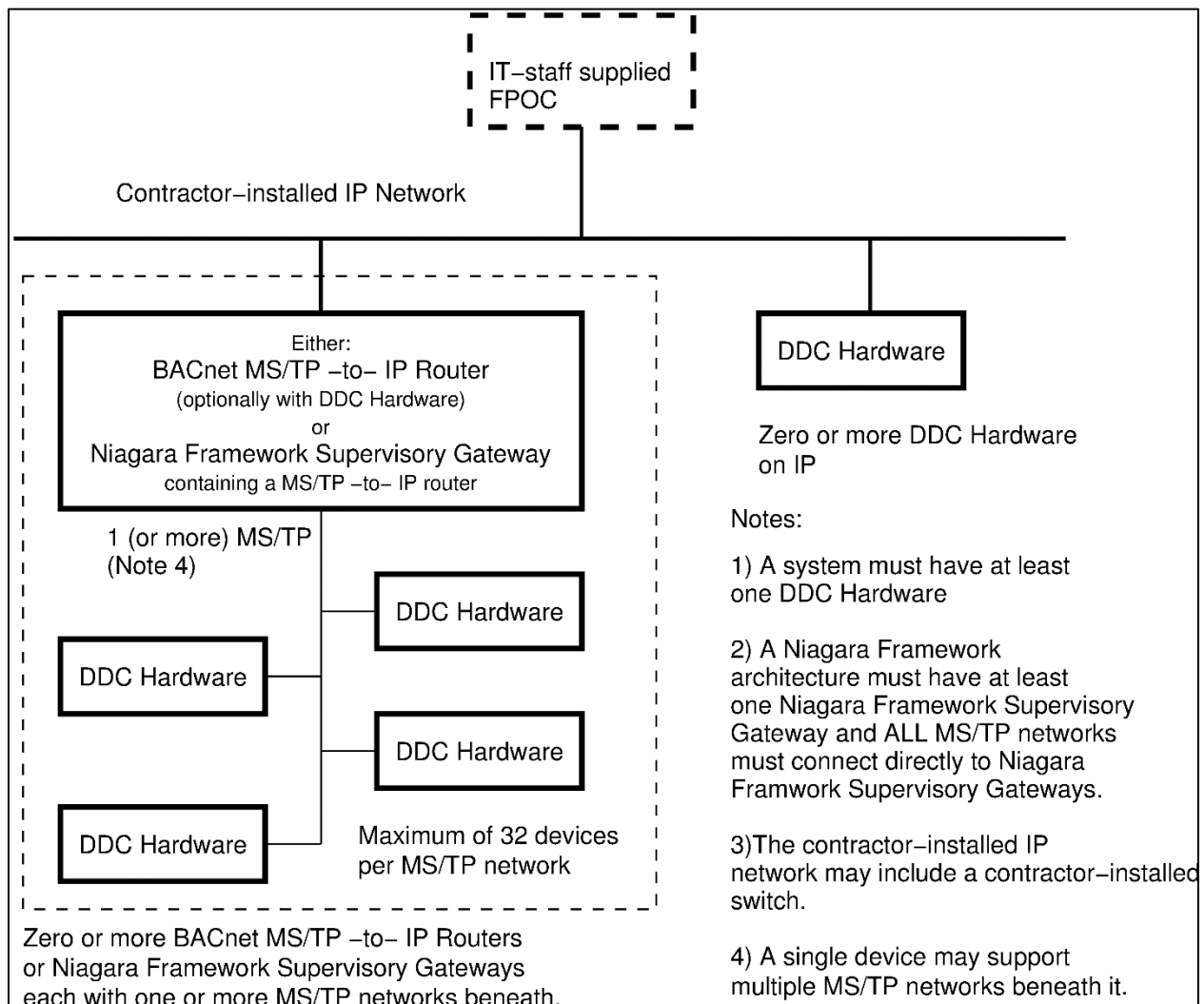

3-4.1 Device and network addressing.

BACnet addressing uses two pieces of data which must be unique throughout the Internetwork - Device IDs and Network Numbers. Unlike Lon-based systems installed under UFGS 23 09 23.01, BACnet does not provide a mechanism to globally manage this data across multiple vendors **and the installation must manually manage these numbers:**

- Network Number. The network number is assigned to every BACnet network and must be unique across the entire BACnet internetwork. The network number is between 1 and 65,535.
 - The basewide BACnet internetwork should have a single BACnet/IP network; all BACnet devices residing on the IP network should have the same BACnet network number. While this network may well span multiple IP subnets, from the perspective of BACnet, it will logically consist of a single BACnet/IP network and only use a single Network Number. This network must be assigned Network Number=1.
 - Each MS/TP network (of which large projects will have several) also needs a site-wide number. Since network numbers can range from 1 – 65,535, and most sites have at most a few thousand buildings, one option is to assign a range of network numbers to each building by building number. So, for example, building 2705 might have network numbers in the range 27,050 – 27,059. Another option is to assign each vendor a range of network numbers and force the vendors to keep track (site-wide) which numbers they have used. Finally, network numbers could simply be assigned site-wide in increasing consecutive order. This requires some care when multiple independent BACnet projects are underway at the same time.
- Device Object Identifier. Every device on the internetwork must have a unique Object identifier for the Device Object, this is often referred to as the Device ID. This number can be any value between 1 and 4,194,302. Similar to Network Numbers, Device IDs must be globally unique within a site (the BACnet internetwork). The same methods suggested for managing MS/TP network numbers can be used for managing Device IDs, with the additional complication that a single project may include devices from multiple vendors and projects using devices from multiple vendors will need multiple tools to manage Device IDs on a single project

Within a specific project, installers will have some method to maintain unique Device Object Identifiers within the device manufacturer's product lines. This however does not guarantee unique Device Object Identifiers across manufacturers. ***It also does not ensure unique Device IDs and Network Numbers when a specific project is later integrated into a basewide BACnet internetwork.*** Coordination with the project site concerning their management procedure for these values is critical. If the project site does not have an existing procedure for managing these values coordinate with them to develop one. For the Army, assistance with the resolution of this issue can be obtained from the UMCS MCX at Huntsville Center.

3-4.2 Media selection.

UFGS 23 09 23.02 specifies the use of either MS/TP or IP.

- Master-Slave/ Token Passing (MS/TP) is a data link protocol as defined by the BACnet standard and the majority of DDC controllers used will communicate BACnet MS/TP over a doubly terminated field bus network compliant with EIA/TIA-485. In order to avoid interoperability issues, MS/TP media shall operate at 38.4 kbps, use 3 wire (twisted pair with reference) with shield media and shall be installed with 2 sets of network bias resistors and no more than 32 nodes per segment. MS/TP is by far the slowest of any media types in either UFGS 23 09 23.01 or UFGS 23 09 23.02.
- Some BACnet controllers will likely use BACnet/IP in accordance with ASHRAE-135 (2012) Annex J. While installation of this media is the responsibility of the controls contractor, this network will, when integrated into a basewide UMCS, connect to the basewide IP network. Future management of the IP network will vary from service to service and possibly even from site to site, but all IP networks will be required to meet some level of Information Assurance (IA) requirements.

Use of other media types may limit future competition by giving an advantage to the limited number of vendors whose products support the non-standard media. Therefore use of alternative media should generally be avoided, though there may be cases (retrofits where it is impossible to run new media) where Zigbee (wireless – but carefully coordinate wireless with the site IT and RF management groups) is desired, or inter-building runs where fiber optic should be considered for its electrical isolation characteristics.

3-5 NIAGARA FRAMEWORK NETWORK.

The Niagara Framework provides an overlay system. At the bottom level of the architecture, there are non-Niagara Framework controllers based on either LonWorks or BACnet. Above those controllers are Niagara Framework Supervisory Gateways which connect the individual building to a Niagara Framework UMCS Front End. These devices function as gateways because the protocol for devices under them is either LonWorks or BACnet, while the protocol above these devices (connecting to the UMCS Front End) is the Fox protocol. In most aspects, the architecture when the Niagara Framework is selected is similar to the base (non-Niagara) architectures discussed above. Differences are discussed below.

3-5.1 Niagara Framework and LonWorks.

The Niagara Framework Supervisory Gateway will take the place of the CEA 852 router to provide a connection to the IP network. The Niagara Framework Supervisory Gateway is a gateway and does not route CEA 709.1 to the IP network. The Niagara Framework Supervisory Gateway is DDC hardware and may be connected directly to the IP network.

The Niagara Framework engineering tool will be used for network management instead of an LNS-based tool. For many requirements, an LNS-based requirement is replaced

with a similar requirement based on the Niagara Framework engineering tool. The communication between the building control system and the front end will be via Fox, not CEA 709.1

3-5.2 Niagara Framework and BACnet.

The Niagara Framework Supervisory Gateway will function as the BACnet MS/TP-to-IP Router. The Niagara Framework Supervisory Gateway does route BACnet, and all MS/TP networks must be connected to a Niagara Framework Supervisory Gateway.

The communication between the building control system and the front end will be via Fox, not BACnet. Non-Niagara devices on the IP network must use the Niagara Framework Supervisory Gateway to communicate with the Niagara Framework front end.

3-6 CONNECTION TO A UMCS.

The building control system will perform all necessary control functionality in a stand-alone mode but does not provide an operator interface (other than local display panels) for monitoring and control of the network. If the building is to be operated in a stand-alone mode for an extended period and monitoring and control functionality are required, use the applicable portions of UFGS 25 10 10 to obtain a local monitoring and control system. Integration of the building control system to the UMCS is specified in UFC 3-470-01 and UFGS 25 10 10.

3-7 NETWORK HARDWARE.

In addition to media, the control network may contain the following types of hardware.

- Repeater: A repeater is a device that connects two (or more) pieces of media, and passes all traffic between the two pieces of media. Repeaters may allow for longer cable runs in some cases, but not others. The BACnet specification does not allow the use of repeaters. The LonWorks specification allows the use of routers which are configured as repeaters (but prohibits “physical layer” repeaters).
- Media Converter: A media converter is a repeater that changes media types. The network architecture defined in UFGS 23 09 23.XX does not use media converters, but they may be needed if non-standard media was authorized.
- Router: A router is similar to a repeater, but performs the additional function of packet filtering based on destination address. A router will only pass traffic that needs to be sent to another output port. Routers may also convert between media types. Both UFGS 23 09 23.01 and UFGS 23 09 23.02 specify the use of routers.

- Gateway: A gateway translates from one protocol to another. The use of gateways, other than Niagara Framework Supervisory Gateway in a Niagara Framework project, is severely restricted in UFGS 23 09 23.XX.

3-8 NETWORK DESIGN AND LAYOUT.

Network layout is left largely to the building-level controls Contractor as specified in UFGS 23 09 23.XX.

While the Contractor is responsible for selecting the details of the architecture and ensuring that the proposed system does not saturate the network, UFGS 23 09 23.XX provide specific additional requirements to help ensure those limits are not exceeded:

- Use of higher speed media and use of a backbone architecture
- Group devices that need to communicate often on a common local control bus
- Limit the amount of information sent to the UMCS. A modern UMCS can easily demand data from the local controls faster than the building network can deliver the data. Coordinate with the UMCS installer to limit “always-active” data requests from the UMCS such as trending to those really required by the installation.
- Ensure the Contractor is careful in selecting data transfer rates and integrity methods. Use “Send on Change” with reasonable change values to avoid sending data more often than required. Except for critical data, do not require an acknowledgement or confirmation that data was received.

3-8.1 Data transmission methods.

There are two primary mechanisms through which data transfer data occurs; polling and send on change. These data transfer aspects of the protocol along with the quantity of data transferred govern how much bandwidth is used. Polling occurs when a receiver of data requests data from a transmitter. This is generally a periodic event with a defined period. Polling can occur at any time and a device can always poll another device for data. Send on change, often referred to as Change Of Value (COV), is another form of data transfer where a data source sends (on its own initiative) data to a recipient. In most cases, the specifications require the use of COV.

3-8.2 Data integrity.

DDC networks are not 100% reliable. While proper network design, media selection and installation can improve network reliability, some dropped data packets are inevitable. Both LonWorks and BACnet have mechanisms to ensure reliable data transmission even when the underlying network is unreliable and the specification requires these methods where appropriate.

3-8.3 Number of controllers per system or sequence.

Although sequences are generally implemented in a single controller with sufficient inputs and outputs, the specifications allow a single sequence or system to be split across multiple controllers. There are designer options in the UFGS to select a preference for one approach over the other. Discuss this with the installation to determine if they have a preference. UFGS 23 09 23.XX places the burden on the Contractor to decide when distributed control should be used.

3-9 CYBERSECURITY.

Cybersecurity is an ever-changing area, and it's vital to coordinate IA requirements both with the site networking personnel and with the respective service or agency for each project. UFC 4-010-06, *Cybersecurity of Facility-Related Control Systems* provides guidance on incorporating cybersecurity into the design of control systems, and includes points of contact for each Service. For the Army, control system design, including cybersecurity, should be coordinated with the UMCS Mandatory Center of Expertise (MCX) at Huntsville.

CHAPTER 4 DIRECT DIGITAL CONTROL HARDWARE AND CONTROL DEVICES

4-1 INTRODUCTION.

This chapter describes control devices and the DDC Hardware specified in UFGS 23 09 23.XX including the extended requirements needed to implement an Open system. It also describes the related terms and concepts pertaining to LONWORKS, BACnet, and the Niagara Framework.

4-2 LONWORKS REQUIREMENTS.

4-2.1 General.

Any device, other than network hardware, that communicates over the CEA 709.1 network is considered DDC Hardware. In general, the term DDC Hardware is used interchangeably with the term controller, but there are devices such as smart sensors and actuators that communicate on the network and are considered DDC Hardware but are not traditionally called controllers even though they may in fact have control functionality (like a feedback control loop). All DDC Hardware must:

- Communicate only using CEA 709.1C using a TP/FT-10 transceiver for use on a TP/FT-10 network at 78.1 kbps.
- Use Standard Network Variable Types (SNVTs). SNVTs provide a common set of standards defining how data is sent over the network, including engineering units
- Meet the LonMark Interoperability guidelines. These guidelines provide a foundation for interoperability and devices meeting these guidelines are readily available.
- Be provided with an external interface file (XIF file). This is a text file that tells a Network Management Tool what the interface (inputs, outputs, configuration settings) of the controller is.

Some of these requirements may be difficult to confirm for some devices, specifically programmable controllers. Product data sheets can provide a good indication of whether a device, particularly an application specific controller, meets LonMark Guidelines. In addition, LonMark International has a self-certification checklist that vendors can use to certify that a device meets the LonMark Guidelines.

Where Lonworks falls short is in defining a standard interface between the BCS and the UMCS front end. In particular, there is no well-supported standard for either alarming or trending; therefore these functions are not specified in UFGS 23 09 23.01 (they are specified in UFGS 25 10 10 if the LonWorks tailoring option is selected). DDC Hardware is further broken down into three categories, Application Specific Controllers,

Application Generic Controllers, and General Purpose Programmable Controllers, each of which has additional requirements it must meet.

4-2.2 Application specific controller.

An application specific controller (ASC) is supplied with a factory-installed (and fixed) application program. Example ASCs include VAV box controllers, fan coil unit controllers, 'smart' actuators and 'smart' sensors. An ASC is configured for the specific application in which it is used. UFGS 23 09 23.01 requires, with rare exceptions, that ASCs be LonMark Certified to meet a specific Functional Profile. Functional Profiles describe standard node communications and consists of mandatory and optional input and output SNVTs, mandatory and optional configuration properties, and finally a manufacturer specific section. UFGS 23 09 23.01 also requires, with rare exceptions that ASCs be provided with an LNS® Plug-in to provide a semi-standard GUI for device configuration

4-2.3 Application generic controller.

An application generic controller (AGC) is similar to an ASC, but has a limited programming capability. Programming these controllers does not change the controller ProgramID, so these controllers can be (and often are) programmed through an LNS plug-in. UFGS 23 09 23.01 has specific requirements for AGCs which includes a mix of ASC and GPPC requirements. These controllers are capable of executing most of the sequences specified in UFGS 23 09 93. Further, since they can be re-programmed remotely and without changing the ProgramID, they are often preferred to GPPCs.

4-2.4 General purpose programmable controller.

A general purpose programmable controller (GPPC) comes from the factory without a fixed application program and must be programmed for the application in which it is used. This makes the GPPC more flexible and powerful than an ASC, but more complicated and costly as well. UFGS 23 09 23.01 requires the GPPC to conform to the LonMark Interoperability Guide. It also requires that the programming software be provided and that a source-code version of the actual program installed in the GPPC be provided as well.

4-3 BACNET REQUIREMENTS.

4-3.1 General.

Any device, other than network hardware, that communicates over the BACnet network is considered DDC Hardware. In general, the term DDC Hardware is used interchangeably with the term controller – this includes smart sensors and actuators that use the network. Another term commonly used is “device”, where a BACnet device is any device that resides on the BACnet network and communicates via the BACnet ASHRAE Standard 135 protocol. All DDC Hardware must:

- Communicate only using BACnet ASHRAE Standard 135.
- Use standard Objects, Properties, and Services. UFGS 23 09 23.02 requires the use of specific Object types to support specific point types.
- Do not use Proprietary Objects or Proprietary Properties. In addition, UFGS 23 09 23.02 places severe restrictions on the use of Proprietary Services.
- Provide Commandable Objects to support overrides.
- Be Listed by BACnet Testing Labs (BTL) (<http://www.bacnetinternational.net/btl/>). For some applications, devices must be listed as either B-BC (BACnet Building Controllers) or B-OD (BACnet Operator Displays).
- Be installed in a manner consistent with both their BTL listing and with the BTL Implementation Guidelines.

Some of these requirements may be difficult to confirm; the PICS is a good place to start for devices. Note, however, that the PICS only describes capabilities, a particular usage of the device may not implement or support every capability described in the PICS. BACnet provides a fairly extensive range of standards defining the interaction between a UMCS front end (specifically a B-AWS) and a BCS, because of this, UFGS 23 09 23.02 has requirements for scheduling, alarming, and trending in the BCS. When BACnet is selected via tailoring option in UFGS 25 10 10, that specification requires that the front end be BTL listed as a BACnet Advanced Workstation (B-AWS).

4-3.2 Scheduling.

UFGS 23 09 23.02 has specific requirements for scheduling, including that scheduling must be performing using Schedule Objects in B-BC devices with support for Schedule creation/modification/deletion from a B-AWS. This last requirement can be partially offset by the provision of extra blank Schedule Objects.

4-3.3 Alarm generation.

The BACnet standard supports 2 primary forms of alarm generation: Intrinsic, where the Object itself incorporates logic to determine if an alarm condition exists, and Algorithmic, where an Event Enrollment Object contains the alarm generation logic. Algorithmic is in turn broken down into Local -- where the Event Enrollment Object is in the same device as the alarm point and Remote -- where the Event Enrollment Object is in a different device. In all cases, a Notification Class Object is also required to send the Event Notification associated with the alarm generation to the B-AWS front end. In order to allow the use of all three types of alarm generation and also ensure that Alarm Generation functionality may be created/modified/deleted from a B-AWS, UFGS 23 09 23.02 has extensive and complex requirements for alarm generation.

4-3.4 Trending.

The BACnet standard provides a Trend Log Object and a Trend Log Multiple Object to support trending. A Trend Log Object supports a single trend; the Trend Log Multiple Object can contain multiple trends. UFGS 23 09 23.02 requires the use of Trend Log and/or Trend Log Multiple Objects and also has additional requirement to support trend creation/modification/deletion from a B-AWS.

4-3.5 Engineering units.

BACnet data does not have pre-determined engineering units and UFGS 23 09 23.02 requires the use of specific engineering units. The choice of either SI or inch-pounds should be coordinated with the site and used on all BACnet projects at that site.

4-4 NIAGARA FRAMEWORK REQUIREMENTS.

4-4.1 General.

Selection of the Niagara Framework is via a tailoring option to either UFGS 23 09 23.01 or UFGS 23 09 23.02. In either case, the requirements normally found in these specification remain largely intact; the tailoring options make specific modifications to support the Niagara Framework. Use of Niagara Framework in the building must be accompanied by selection of the Niagara Framework tailoring option in UFGS 25 10 10.

4-4.2 Niagara Framework and LonWorks (UFGS 23 09.01).

The most significant changes that will result from use of the Niagara Framework tailoring option in UFGS 23 09 23.01 are:

- Network configuration and network management will be via the Niagara Framework Engineering tool rather than an LNS-based tool. Similarly, Niagara Framework Wizards may be required rather than LNS-plugins
- Connections to the IP network will be via Niagara Framework Supervisory Gateways rather than CEA 852 Lon-to-IP routers.
- Scheduling, Alarming, and Trending will be via Niagara Framework Supervisory Gateways located in the building.
- Some DDC Hardware requirements, as they apply to Niagara Framework Supervisory Gateways, are depreciated in favor of Niagara-specific requirements.

4-4.3 Niagara Framework and BACnet (UFGS 23 09.02).

The most significant changes that will result from use of the Niagara Framework tailoring option in UFGS 23 09 23.02 are:

- Niagara Framework Engineering tool will be used for some aspects of device configuration. Note that vendor specific tools will likely still be required for many aspects
- Connections to the IP network will be BACnet MS/TP-to-IP routers in Niagara Framework Supervisory Gateways
- Scheduling, Alarming, and Trending will be via Niagara Framework Supervisory Gateways rather than the normal BACnet implementation methods.
- Some DDC Hardware requirements, as they apply to Niagara Framework Supervisory Gateways, are depreciated in favor of Niagara-specific requirements.

4-5 OTHER ISSUES.

4-5.1 Expansion modules and tethered hardware.

UFGS 23 09 23.XX considers hardware expansion modules and tethered hardware to be part of a single piece of DDC Hardware. Expansion modules typically provide additional I/O and are designed to connect directly to the base (main) DDC Hardware. Tethered hardware is functionally similar to expansion modules, but is connected to the base unit by a cable. The intent of the requirements is to allow a single device to be split among multiple physical pieces of hardware, not to allow multiple devices to be connected together using a proprietary protocol.

4-5.2 Building management interface.

A building-level project might call for a local building management interface. This should only be used in the absence of a UMCS, and is not specified in either UFGS 23 09 23.XX or UFGS 25 10 10. This interface provides web services and can also perform scheduling, logging (trending), alarming, and other supervisory interface functions. Note that if it is later decided to connect the building to a UMCS, the interface will need to be replaced and any functionality in it will need to be accomplished in an Open manner in accordance with UFGS 23 09 23.XX or UFGS 25 10 10. On the other hand, a Niagara Framework Supervisory Gateway can provide this interface and can later be integrated into a Niagara Framework front end. UFGS 23 09 23.XX has a designer option to require serving web pages from the Niagara Framework Supervisory Gateway. Any web server within the building should be carefully coordinated with the site IT staff.

4-5.3 Local Display Panel.

The local display panel (LDP) is a device with a small display screen and some navigational buttons used to view and/or change the value of network variables. Although the functionality of an LDP is limited as compared to an operator workstation computer, it can be a useful diagnostic tool for maintenance staff and can often be used

as a limited building interface until the building can be integrated into a UMCS.
Coordinate with the site O&M staff regarding number and location of LDPs desired.

Note that there may be drawbacks to allowing overrides from both the M&C software and from an LDP. The value of specifying LDP override capability may be sufficiently beneficial to compensate for the potential confusion, but this should be coordinated with the project site.

4-5.4 Networked sensors and actuators.

Sensors and actuators may be networked devices. A common example would be a variable frequency drive unit containing a network interface. The choice of whether to provide a so-called “smart” sensor or actuator is left to the contractor. These “smart” devices are considered DDC Hardware and must meet both the DDC Hardware requirements as specified in UFGS 23 09 23.XX and any sensor or actuator requirements as specified in UFGS 23 09 13.

4-5.5 Hand-Off-Auto (H-O-A) Switches.

UFGS 23.09.23.XX has a number of general designer options for requiring Hand-Off-Auto switches. These are in addition to those already required by specific sequences of operation. In general, it is preferable to use overrides rather than H-O-A switches and the design should reflect this preference.

CHAPTER 5 CONTROL SYSTEM DRAWINGS

5-1 CONTROL SYSTEM DRAWINGS OVERVIEW.

A complete design must include the following project drawings:

- Index (title sheet)
- Symbols and Legend drawing
- Points Schedule Instructions for the Installing Contractor

as well as the following HVAC system-specific drawings as applicable to the HVAC system:

- Control Schematic
- Ladder Diagram
- Control Logic Diagram (OPTIONAL)
- Sequence of Operation
- Points Schedule
- Thermostat and Occupancy Sensor Schedule
- Occupancy Schedule
- Control Damper Schedule
- Control Valve Schedule

5-2 SAMPLE DRAWINGS.

Sample drawings are available online at the “UFGS Forms, Graphics and Tables” page at the Whole Building Design Guide at <https://www.wbdg.org/ffc/dod/unified-facilities-guide-specifications-ufgs/forms-graphics-tables>. The use of the sample drawings is recommended. Points Schedule drawings must contain all fields in the sample drawing which are relevant to the project, and the use of the sample Points Schedule drawings as a template is strongly recommended.

5-2.1 Brackets in sample drawings.

As part of the editing process to make the sample drawings project-specific, the sample drawings use the following conventions:

- Entries required of the designer are shown bracketed as: [____]

- Entries required of the Contractor are shown bracketed as: < ___ >
- Spaces where no entry is ordinarily required contains a tilde: “ ~ “ (equivalent to an “n/a” or null value)

The bracketed [___] designer entries in the sample drawings are shown/provided as a guide to the designer. These entries must be verified or changed by the designer. When editing the drawings, delete the brackets after verifying/providing the entry. Contract drawings should contain no designer brackets [___]. Do not leave cells blank. Instead show the tilde (“~”) to indicate a null value or that no further entry is required.

5-3 UNIQUE IDENTIFIERS.

Use unique identifiers to identify components across control systems drawings. APPENDIX E describes the point naming convention used in the sample drawings. Unless otherwise required, use the point naming convention in the sample drawings for the project drawings.

5-4 POINTS SCHEDULE.

5-4.1 Overview.

The Points Schedule drawing conveys a great deal of information critical to the design, installation, and subsequent performance of the control system. It includes hardware input/output information, device ranges and settings, and protocol specific information. It also includes information about data that is to be accessible at the operator workstation by the UMCS UFGS 25 10 10 Monitoring and Control software.

5-4.2 Responsibilities.

The designer is responsible for the initial set of Points Schedule entries and for creating the Points Schedule Instructions drawing (using the Instructions in ~~V2~~ APPENDIX D ~~/2/~~ of this UFC) . The Building Controls Contractor is responsible for the bulk of the entries and submits the Points schedule as a Design Drawing for government approval and then finalizes it as an As-Built submittal. The As-Built is then used as a Contract Drawing by the UMCS Contractor. Finally, the completed Point Schedule is submitted by the UMCS Integration Contractor as an As-Built submittal.

Detailed responsibilities for each column in the Point Schedule are shown under the description for each column.

5-4.3 UMCS content shown on UFGS 25 10 10 points schedules.

Some columns in the Points Schedule (labeled “M&C”) pertain to functionality provided by the Monitoring and Control (M&C) Software specified in UFGS 25 10 10. These columns include information that the building controls system must provide for present or future use by the UMCS. Then, as stated in the Points Schedule Instructions

drawing, when the building control system is integrated into a UMCS, these columns tell the UMCS Contractor what functionality to configure in the M&C Software.

If the building will be 'stand-alone' and M&C functionality is required at the building level (to be provided by the DDC building control system contractor), certain requirements from UMCS UFGS 25 10 10 must be added to the building controls specification or an edited version of UMCS UFGS 25 10 10 must be used in conjunction with the building controls specification. Note that in the absence of adequate documentation on the Points Schedule by the DDC Contractor, the UMCS Contractor will be unable to integrate the building into the UMCS.

5-4.4 Points Schedule Description and Instructions.

APPENDIX D contains a detailed description of the Points Schedule and instructions for its use.

5-5 CONTROL SYSTEM SCHEMATIC.

The control system schematic provides a functional representation of the control system. It shows control loops, control system devices, their symbols, unique identifiers, and associated input and output signals. It also contains space for designer notes. Depending upon the particular system, the control system schematic might also show Sequencing Diagrams. It is used to complement the sequence of operation, along with the other control system drawings, and must be coordinated with the sequence of operation and the devices and signals shown in the other drawings.

5-5.1 Loops and devices.

Each control system schematic consists of one or more loops with associated control hardware and devices including DDC hardware, input devices (sensors and other instrumentation), output devices (valves/dampers/fans/pumps), and multi-function devices. With few exceptions, such as valves, dampers, fans, and pumps, all control devices and signals shown in the Control Schematic should also be shown in the Points Schedule. Valve and damper details are shown in their respective schedules.

The control system schematic must be edited to be project specific and consistent with the other Contract drawings:

- Edit the border as required.
- Provide/show an identifier for the 'system'.
- Add or delete loops and devices as required.
- Show other points (sensors) that will be used for monitoring purposes only and show these Other Points in the Points Schedule.
- Show pneumatic actuation if desired, including positive positioners. By default, valve and damper actuators will use electric actuation.

- Where applicable, show the locations of permanent instrumentation in coordination with other drawings (M-plates).

5-5.2 Sequencing diagrams.

A Sequencing Diagram shows the heating, deadband, and cooling temperature ranges for controlled devices and equipment. Default Sequencing Diagrams are shown on the sample control drawings and must be edited to be project specific. Show device sequencing for primary equipment such as single-zone air handlers, multizone zone temperature controls and terminal unit equipment, such as VAV boxes and fan coil units on the Control Schematic. In most cases, the sequencing is dependent upon the mode of operation such as occupied, unoccupied, and warm-up/cool-down. Sequencing is further described in the respective written Sequence of Operation and, when used, the Control Logic Diagram.

5-5.3 Designer notes.

The Control System Schematic has space provided for designer notes including pre-defined/default notes.

5-6 LADDER DIAGRAM.

The ladder diagram, sometimes referred to as a fan or pump starter circuit or wiring diagram, shows control system equipment interlocks and interfaces. In most cases, these interlocks will be with fan and pump motor starters or variable frequency drive units. In the case of HVAC system equipment, the interlocks will usually include hand-off-auto switches, freeze stats, smoke detectors, fire alarm panel interface, and the emergency shutdown switch. Default Ladder Diagrams are shown on the sample control drawings and should be edited to be project specific.

Figure 5-1 Sample Ladder Diagram

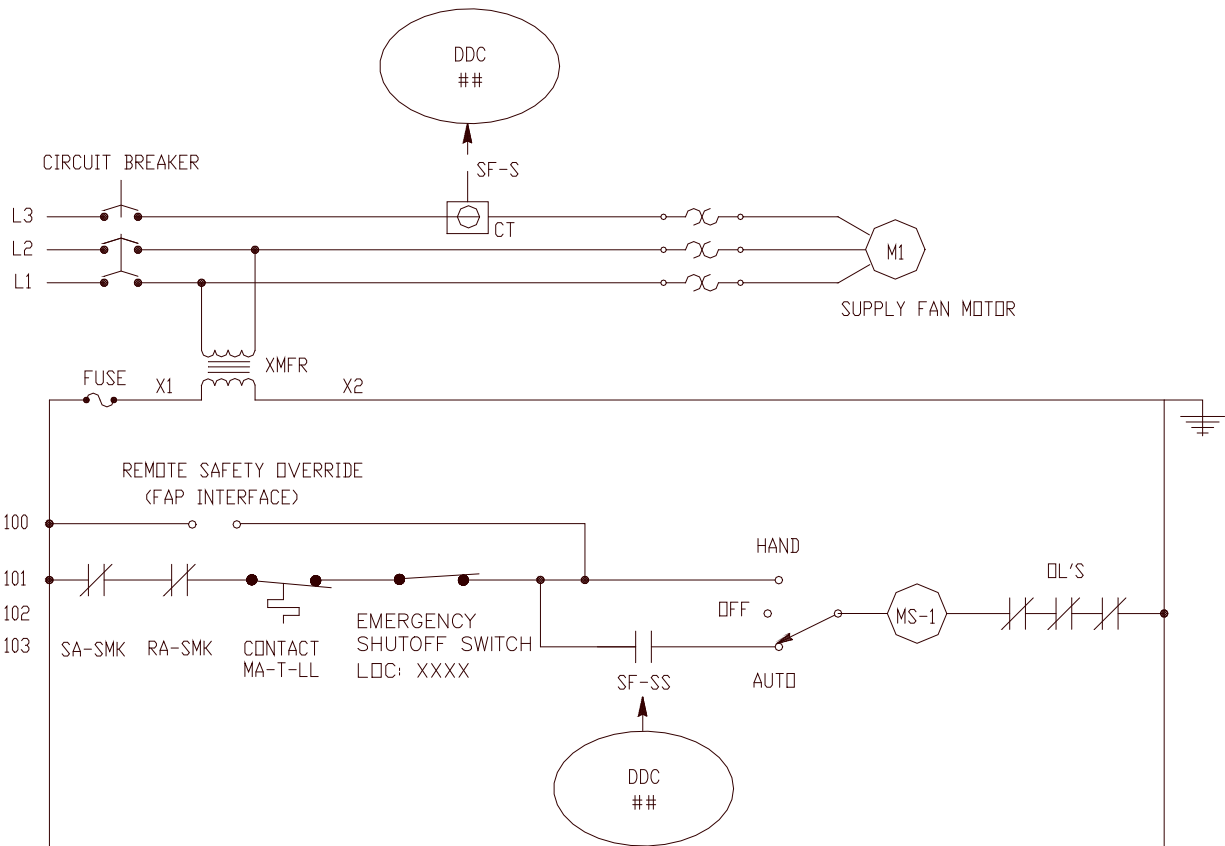

5-7 CONTROL LOGIC DIAGRAM.

The control logic diagram (CLD) drawing is intended to be an unambiguous graphical description of the control system sequence of operation. It provides detail that may not be evident in the written sequence. The focus of the CLD is on control logic, not on a particular hardware implementation. Inclusion of a CLD in the Contract drawing package is optional depending on the desired degree of specificity in the design. Use of a CLD is recommended where precise implementation of a particular control sequence is needed. It is also beneficial as part of project quality verification as it can be used as a tool to verify proper implementation of the control sequence.

The CLD must be edited to be project specific and consistent with the other Contract drawings. A control logic diagram overview is contained in APPENDIX F

5-8 SEQUENCE OF OPERATION.

The sequence of operation drawing shows a written description of the control logic. Example written sequences are in UFGS 23 09 93. To avoid confusion, these sequences were not repeated on the sample control drawings. The sequence must be

edited to be project specific and consistent with the other Contract drawings and be copied onto the Sequence of Operation drawing.

5-9 THERMOSTAT AND OCCUPANCY SENSOR SCHEDULE.

The Thermostat and Occupancy Sensor Schedule (Figure 5-2) shows requirements for space mounted devices.

Figure 5-2 Thermostat and Occupancy Sensor Schedule.

SYSTEM SERVICE (AHU)	TERMINAL UNIT IDENTIFIER	SPACES SERVED	STAT LOCATION	ZN-T	ZN-T-SP ADJUST	UNOCC OVERRIDE PUSHBUTTON	UNOCC OVERRIDE TIME	OCC SENSOR
[_____]		RM-[_____] RM-[_____]	RM-[_____]	[_]	[_]	[_]	[_____]	[_]
[_____]		RM-[_____] RM-[_____] RM-[_____]	RM-[_____]	[_]	[_]	[_]	[_____]	[_]
[_____]		RM-[_____]	RM-[_____]	[_]	[_]	[_]	[_____]	[_]

5-9.1 Thermostats.

Note that the definition of a thermostat (STAT) is used somewhat loosely here in that (contrary to the historical definition, but in line with current usage) the thermostat does not necessarily provide a control output (to modulate or position an end device). Instead, the thermostat will contain a temperature sensor and one or more of an occupant adjustable setpoint input, an occupancy sensor, or an unoccupied mode override (manual pushbutton). The intent and application of a thermostat, along with the technical requirements, are clear in the drawings and specifications (including 'User Input Devices' and 'Multifunction Devices').

5-9.2 Occupancy sensors.

Space occupancy input(s) may consist of an occupancy sensor and/or a local push-button. Occupancy sensor location, within the room/space, is left up to the Contractor. If ceiling mount sensors are preferred, edit the sequences and/or indicate in the Thermostat and Occupancy Sensor Schedule.

5-9.3 Schedule entries.

Show project specific entries in the Thermostat and Occupancy Sensor Schedule columns:

- System Service: Show an identifier for the system, such as the air handler, that services/supplies the space. Ensure coordination/consistency with other mechanical system drawings.
- Terminal Unit Identifier: Show an identifier when applicable, such as in a VAV system. Ensure coordination/consistency with other mechanical system drawings.
- Spaces Served: Show the room or rooms serviced by the thermostat and/or occupancy sensor. In general, all stats and occupancy sensors for a given terminal unit should be shown on the same line. However, there may be cases where additional rows may be required. For example, if a VAV zone consists of multiple spaces, a single thermostat but multiple occupancy sensors (one in each space/room) may be desired. The designer might choose to show a separate row for each occupancy sensor. Alternatively, a comment could be added to the column entitled 'Other' to clarify the requirement for a single thermostat with multiple space occupancy sensors.
- STAT Location: Show the physical location of the thermostat.
- ZN-T: Thermostats should always include a temperature sensor, so there should always be an 'X' in this column.
- ZN-T-SP Adjust: Show an 'X' if the thermostat is to include an occupant adjustable setpoint (thumb wheel or sliding bar). Where a non-(occupant)-adjustable setpoint is specified, show the (configured) setpoint in the Points Schedule. When using non-adjustable setpoints, be sure to indicate on the Points Schedule that the setpoint must be capable of being overridden from the M&C Software or an LDP.
- OCC Pushbutton: Show an 'X' if the thermostat is to include an occupant accessible pushbutton to override the unoccupied mode and start the servicing system for a duration shown under the UNOCC Override Time.
- OCC Pushbutton Time: If an 'X' is shown in the UNOCC Override Pushbutton column, show the time duration that the system will remain in Occupied mode after pressing the UNOCC Override Pushbutton.
- OCC Sensor: Show an 'X' if the space is to include an occupancy sensor. The occupancy sensor specification requires a 15 minute off-mode delay prior to leaving the occupied mode. If a different time is desired, show it in the thermostat schedule and ensure that it is consistent with the specifications.

5-10 OCCUPANCY SCHEDULE.

The Occupancy Schedule shows the system modes (Occupied, Unoccupied, and Warm-Up/Cool-Down) and when the system should be in each mode. Two sets of times are shown. One for the normal operating schedule set at the UMCS and one for the default schedule in the building which is active if connection to the UMCS is lost. In addition, the number of occupancy sensors that are required to be reporting as 'occupied' before the system air handler is put into occupied mode is shown on this schedule

5-10.1 System default schedule.

The System Default Schedule is configured in the System Scheduler by the controls Contractor. This schedule is a '7-day' schedule. In other words, the schedule can differ by day of the week but not day of the year. This schedule should be as simple as possible with one set of times for weekdays and one for weekends. An extended Occupied mode is recommended and should encompass warm-up/cool-down times. For example, if the building is normally in Warm-Up from 0700-0800 and Occupied mode from 0800-1800, a reasonable default schedule might be for the building to be in Occupied mode from 0530-1930. When choosing times for the default schedules for systems with occupancy sensors, the Occupied mode times can be shorter since the occupancy sensors (or override buttons) can still put the system into an Occupied mode.

5-10.2 Supervisory monitoring and control schedule.

The Supervisory Monitoring and Control (M&C) Schedule is configured at the M&C software by the UFGS 25 10 10 Contractor. Once a building is connected to the UMCS, this is the schedule that systems in the building will use. Although this schedule can include exceptions for holidays, it is recommended that the designer coordinate with the project site before requiring the implementation of these exceptions. Since the date of most holidays needs to be adjusted year-by-year, the project site O&M staff will need to reconfigure them yearly. As with the default schedule, the presence of Occupancy Sensors should be considered when choosing Occupied mode times.

5-10.3 Number of occupancy sensors to put AHU in occupied mode.

Systems with occupancy sensors (or override buttons) can be placed into the Occupied mode by the occupancy sensors when a minimum number of occupancy sensors detect that the space they serve is occupied. Indicate the required number of occupancy sensors in this column.

CHAPTER 6 BUILDING CONTROL SYSTEM DESIGN AND IMPLEMENTATION

6-1 INTRODUCTION.

This chapter describes the planning and design of a DDC project.

6-2 PLANNING.

In addition to the guidance contained in this UFC, the design should be based on site-specific planning documents. Designs must be accomplished in accordance with the customer's site specific requirements such as, in the case of a Corps of Engineers project, the Installation Design Guide (IDG), Master Planning documents, and the UMCS/DDC Implementation Plan. To help obtain maximum benefit of Open DDC systems, designers should encourage their customers to develop a UMCS/DDC Implementation Plan. Development of an Implementation Plan is recommended in Engineering Construction Bulletin (ECB) 2007-8 and is described in ERDC/CERL Technical report TR-08-12 'IMCOM LONWORKS® Building Automation Systems Implementation Strategy'. This Technical Report is available at: <http://dtic.mil/dtic/tr/fulltext/u2/a492015.pdf>

6-3 CHOICE OF SPECIFICATION AND PROTOCOL.

The first decision that must be reached for the building is the choice of protocol, one of:

- LonWorks with LNS (use UFGS 23 09 23.01 with the LNS tailoring option),
- LonWorks with Niagara Framework (use UFGS 23 09 23.01 with the Niagara Framework tailoring option),
- BACnet (use UFGS 23 09 23.02 with the non-Niagara tailoring option), or
- BACnet with Niagara Framework (use UFGS 23 09 23.02 with the Niagara Framework tailoring option).

In most cases, selection of protocol will be dictated by the need to integrate to a specific UMCS. Selection of protocol is extensively described in UFC 3-470-01.

6-4 INTEGRATION TO UMCS.

Most buildings will eventually be integrated to a UMCS. Even if, at the time, it seems like the project is for a stand-alone building, the realities of O&M staffing at most installations make it advantageous to integrate buildings into a single UMCS and the decision to procure a building with no planning for future integration is generally very short-sighted. There are legitimate exceptions for buildings that will not (and likely will never) be maintained by the installation staff – e.g. hospitals and other tenants who have their own O&M staff. In many cases, it is desirable to perform this integration as part of the building project. In this case, use DDC UFGS 23 09 23.XX for the present building-level project and use an edited version of UMCS UFGS 25 10 10 to specify the

integration of the building system to the UMCS (UMCS UFGS 25 10 10 is designed to make this editing task straightforward). If integration is not performed as part of the building project, an integration project will be necessary later using an edited version of UFGS 25 10 10. If there will be a significant time lapse between building construction and integration, the building controls project may wish to include additional LDP functionality.

One possible issue is that the site may not have a UMCS that the project can integrate to, in which case the site should consider adding requirements for a UMCS to the building control project. This can often be an effective approach, particularly if the building project spans multiple buildings. See UFC 3-470-01 and UFGS 25 10 10 for guidance and requirements on procuring a UMCS.

6-5 PROCUREMENT CONSIDERATIONS.

6-5.1.1 Non-proprietary procurement.

Unless there is specific written authorization from the Project Manager or Authority Having Jurisdiction, the project shall use non-proprietary procurement using requirements in UFGS 23 09 23.XX.

6-6 DDC DESIGN.

6-6.1 General.

2\ 2/

Much of the needed detail was attended to during the development of the UFGS and UFC criteria. Still, project specific requirements must be defined by the designer and the specifications and drawings edited accordingly. This notably includes, but is not limited to, editing the Points Schedule drawing to show critical Open system requirements.

The resultant project-specific specification will require the control system Contractor to produce shop drawings, schedules, instructions, test plans, test procedures, testing procedures, and other documents showing the application of products to implement the control system design. The specification will require the Contractor to implement the building-level network in a manner that is consistent with performance requirements defined in the specification. The specification will further require that the Contractor perform calibration, adjustments, and testing of the control system and document the testing to show that the control system functions as designed.

6-7 DRAWING PACKAGE.

Assemble and edit the drawing package as described in CHAPTER 5 CONTROL SYSTEM DRAWINGS.

APPENDIX A REFERENCES

UNIFIED FACILITIES CRITERIA

http://www.wbdg.org/ccb/browse_cat.php?o=29&c=4

UFC 1-200-01, *DoD Building Code (General Building Requirements)*

UFC 3-470-01, *Utility Monitoring and Control System (UMCS) Front End and Integration*

UFC 4-010-06, *Cybersecurity of Facility-Related Control Systems*

UNIFIED FACILITIES GUIDE SPECIFICATIONS

<http://www.wbdg.org/ffc/dod/unified-facilities-guide-specifications-ufgs>

UFGS 23 09 00, *Instrumentation and Control for HVAC*

UFGS 23 09 13, *Instrumentation and Control Devices for HVAC*

UFGS 23 09 23.01, *LonWorks Direct Digital Control for HVAC and Other Building Control Systems*

UFGS 23 09 23.02, *BACnet Direct Digital Control for HVAC and Other Building Control Systems*

UFGS 23 09 93, *Sequences of Operation for HVAC Control*

UFGS 25 05 11, *Cybersecurity for Facility-Related Control Systems*

UFGS 25 10 10, *Utility Monitoring and Control System (UMCS) Front End and Integration*

This Page Intentionally Left Blank

APPENDIX B BEST PRACTICES

(not used)

This Page Intentionally Left Blank

APPENDIX C GLOSSARY

C-1 ACRONYMS

BCN	Building Control Network
BCS	Building Control System
CCR	Criteria Change Request
DDC	Direct Digital Control
FPOC	Field Point of Connection
HVAC	Heating Ventilating and Air Conditioning
IDG	Installation Design Guide
IP	Internet Protocol
IT	Information Technology
LNS	LonWorks Network Services
M&C	Monitoring and Control
MCX	Mandatory Center of Expertise
NCT	Network Configuration Tool
NDAA	National Defense Authorization Act
O&M	Operations and Maintenance
PDF	Portable Document Format
PID	Proportional, Intergal, Derivative
UFC	Unified Facilities Criteria
UFGS	Unified Facilities Guide Specification
UMCS	Utility Monitoring and Control System
USACE	U.S. Army Corps of Engineers
VAV	Variable Air Volume

C-2 DEFINITION OF TERMS

Several terms are defined in this appendix for ease of reference, but UFC 4-010-06 contains a more extensive, and definitive, list of terms. Should the definitions provide here and in UFC 4-010-06 conflict, the definitions in UFC 4-0101-06 should be used, and a Criteria Change Request (CCR) should be submitted to update the definitions in this UFC.

C-2.1 Field Control System (FCS) and Field Control Network (FCN).

A Building Control System or Utility Control System. The network used by the field control system is called the field control network (FCN).

C-2.1.1 Building Automation System (BAS).

The system consisting of the UMCS Front-End and connected building control systems which provides for control of the building electrical and mechanical systems as well as a user interface and supervisory capability (i.e. the portion of the UMCS for building control and excluding any connected UCS).

C-2.1.2 Building Control System (BCS) and Building Control Network (BCN).

One type of Field Control System. A control system primarily for building electrical and mechanical systems, typically HVAC (including central plants) and lighting. Building Control Systems are generally composed of direct digital controls (DDC) and do not have a full-featured user interface. They may have some local user interface such as “local display panels” but rely on the UMCS for the full user interface functionality. The network used by the building control system is called the building control network (BCN).

C-2.1.3 Utility Control System (UCS) and Utility Control Network(UCN).

One type of Field Control System. Used for control of utility systems such as an electrical substation, sanitary sewer lift station, water pump station, etc. Building controls are excluded from a UCS, however it is possible to have a Utility Control System and a Building Control System in the same facility, and for those systems to share components such as the Field Point of Connection (FPOC). A UCS may include its own local front-end.

C-2.2 Field Point of Connection (FPOC)

The connection point between the field control network (installed by the controls contractor) and the UMCS network (generally owned and installed by the installation IT staff). The FPOC device is typically on the IP network – usually a managed switch, owned and managed by the installation IT staff, and a focal point for Cybersecurity. Note that this definition has evolved over time and may be at variance with older usage of the term.

C-2.3 Industrial Control System (ICS)

One type of control system. Most specifically a control system which controls an industrial (manufacturing) process. Sometimes also used to refer to other types of control systems, particularly utility control systems such as electrical, gas, or water distribution systems.

Note that ICS is at times used to mean “all control systems”, so care must be taken to interpret the term in the appropriate context.

C-2.4 Utility Monitoring and Control System (UMCS)

The system consisting of one or more field control systems connected to a UMCS Front-End which provides for control of the electrical and mechanical systems as well as a user interface and supervisory capability. (i.e. the complete system consisting of the UMCS Front-End with all connected BCS and UCS systems). Note that in the past the term “UMCS” has sometimes been used to mean just “the UMCS front end”, but is no longer used in this manner.

C-2.5 Utility Monitoring and Control System (UMCS) Front End

The portion of the UMCS consisting primarily of computers running software to provide a full-featured user interface. In addition to providing a full user interface, this system performs functions such as alarming, scheduling, data logging, electrical demand limiting and report generation. The front end does not directly control physical systems; it interacts with them only through field control systems.

C-2.6 Utility Monitoring and Control System (UMCS) IP Network

The IP network used by the UMCS Front End for communication between Field Control Systems. This includes the IP infrastructure components only. The UMCS IP network is often also referred to as the “platform enclave” for cybersecurity purposes.

C-3 TERMS SPECIFICALLY NOT USED BY THIS UFC

The term SCADA (Supervisory Control and Data Acquisition) is not used as the definition can vary depending on context. In general usage, however, “SCADA” can be taken to mean “UCS”.

NDAA 2010 uses the term Energy Monitoring and Utility Control System to refer to a Utility Monitoring and Control System (UMCS). This term is not a standard term used by the controls industry, so this UFC and UFGS 25 10 10 do not use this term.

C-4 OTHER TERMINOLOGY

Other terminology related to control systems is defined in UFGS 25 10 10 and in the field control system specifications (e.g. UFGS 23 09 00, UFGS 23 09.01, and UFGS 23 09.02).

This Page Intentionally Left Blank

APPENDIX D POINTS SCHEDULE IINSTRUCTIONS

D-1 USE OF BRACKETS IN THE POINTS SCHEDULE

As with guide specifications, the Points Schedule uses brackets to indicate where entries or selections are required. Unlike with the guide specifications, however, two types of brackets are used in the Points Schedule. “Square brackets” (“[]”) are used to indicate selections or entries made by the designer, while “angle brackets” (“< >”) are used to indicate selections or entries that must be made by the building control system contractor.

The building control system contractor is responsible for completing the entire Points Schedule regardless of the presence or absence of “angle brackets”. “Angle brackets” are used in sample drawings to indicate to the designer information they would not typically provide. They may also be used by the designer to highlight specific information they have decided not to provide or have determined must be provided by the Contractor.

D-2 POINTS SCHEDULE DESCRIPTION AND INSTRUCTIONS

Points Schedule columns and entries are described below along with the Designer and Contractor responsibilities related to that column. For each column in the point schedule, the instructions below provide the following data:

APPLICABILITY: Not all columns are used for all protocols. This entry defines which protocol(s) (SpecsIntact tailoring options) the column is used with. “Any” means “use this column regardless of the protocol tailoring option chosen”.

PURPOSE: The intent of the column; why it is necessary

VALID ENTRIES: What are the allowed entries for this column? Note that these are given for a “complete” table, while a designer might, for example, enter “< >” to indicate that this information will be provided later by the Building Contractor, this is not regarded as a “Valid Entry”. If the information is not needed, then the valid entries are “~” or “N/A” (Note that, to avoid confusion, a blank entry is not a valid entry – do not leave cells blank.):

- An “N/A” (or a greyed out cell, or a combination of N/A and a greyed out cell) is used when there is no possibility of a valid entry for that particular cell.
- A tilde (“~”) is used in a cell where there could be a valid entry, but no entry is required (i.e. it’s specifically used to mean “I could have put a value here but I chose not to enter one”).

DESIGNER: Describes designer responsibilities associated with the entry.

BUILDING CONTRACTOR: Describes building contractor responsibilities associated with the entry.

UMCS CONTRACTOR: Describes UMCS contractor responsibilities associated with the entry.

In some cases, the contractor instructions are further divided by protocol. "Other" means "a protocol other than the ones specifically enumerated", while "All" means "any and all protocols, including those specifically enumerated".

Note that while these instructions are complete and authoritative, they may omit some details which are covered either elsewhere in this UFC or the relevant UFGS. In all cases, the designer and contractor are responsible for implementing the requirements of the UFC and UFGS.

D-2.1 General Columns

D-2.1.1 Function

APPLICABILITY: Any protocol

PURPOSE: Describe the functionality of this group of points

VALID ENTRIES: Functional blocks from sequence of operation

DESIGNER: Provide this information

BUILDING CONTRACTOR: None, informational only

UMCS CONTRACTOR: None, informational only

D-2.1.2 Point Name

APPLICABILITY: Any protocol

PURPOSE: The point name

VALID ENTRIES: As shown on sample Points Schedules, or using the point naming convention in APPENDIX E

DESIGNER: Provide this information

BUILDING CONTRACTOR: Provide this information for any additional points needed or where designer did not provide an entry.

UMCS CONTRACTOR: Show these point names on graphic displays

D-2.1.3 Description

APPLICABILITY: Any protocol

PURPOSE: The point description

VALID ENTRIES: Functional description of the point.

DESIGNER: Provide this information

BUILDING CONTRACTOR: Provide this information for any additional points needed or where designer did not provide an entry.

UMCS CONTRACTOR: These values should be displayed on a graphic when an operator requests additional details (“Properties”) for a point

D-2.1.4 DDC Hardware ID

APPLICABILITY: Any protocol

PURPOSE: The unique identifier used in the documentation for the DDC Hardware containing the point. This is the identifier for the device used across all drawings.

VALID ENTRIES: Unique Identifier from the Equipment Schedule

DESIGNER: None

BUILDING CONTRACTOR: Provide this information

UMCS CONTRACTOR: None, informational only

D-2.1.5 Setting

APPLICABILITY: Any protocol

PURPOSE: This shows all settings related to the point, such as setpoints and configuration parameters. These are values established in the controller by the building control system contractor, either by dip switches, hardware settings, or engineering software such as controller programming or configuration software.

VALID ENTRIES: Typical values are shown in the sample drawings

DESIGNER: Show setpoints and settings, including appropriate engineering units, as required.

BUILDING CONTRACTOR: Use these settings when configuring devices and provide the setting used where the design did not show or specify one.

UMCS CONTRACTOR: None, informational only

D-2.1.6 Range

APPLICABILITY: Any protocol

PURPOSE: Shows the range of values associated with the point. For example, it could be a zone temperature setpoint adjustment range, a sensor measurement range, occupancy values for an occupancy input, or the status of a safety.

VALID ENTRIES: In general, provide values for the following types of points:

- Zone setpoints
- Switch settings
- Occupancy modes

Note that ranges must meet UFGS 23 09 13 (e.g. permissible range of a temperature sensor). For sensors, show the actual sensor range, which must at least encompass the range specified in section 23 09 13. For actuators show the actual range over which the valve or damper is actuated and indicate whether the maximum value corresponds to a more open or more closed damper or valve.

DESIGNER: Provide this information, including engineering units, or use “< >” to indicate that the building control system contractor is to provide this information

BUILDING CONTRACTOR: Use these ranges when configuring devices, and document the ranges used when designer did not provide an entry.

UMCS CONTRACTOR: None

D-2.1.7 I/O Type

APPLICABILITY: Any protocol

PURPOSE: Shows the input/output signal type (if any) associated with the point.

VALID ENTRIES: One or more of:

- AI: The value comes from a hardware (physical) Analog Input
- AO: The value is output as a hardware (physical) Analog Output
- BI: The value comes from a hardware (physical) Binary Input
- BO: The value is output as a hardware (physical) Binary Output
- PULSE: The value comes from a hardware (physical) Pulse Accumulator Input
- NET-IN: The value is provided from the network (generally from another device)
- NET-OUT: The value is provided to another controller over the network

Note that NET-IN and NET-OUT entries are not used for all values that exist on the network, but rather only when the value is specifically input from or output to another device which uses the value as part of its sequence. Network values used only for trending, alarming, overrides or display at a workstation should not use NET-IN or NET-OUT entries. In other words, absence of a “NET-IN” or “NET-OUT” tag does

not mean that the point does not need to be exposed on the network, merely that the point is not shared as part of a sequence.

Note that a point might require two entries, for example an AI that is also used by another device (“AI / NET-OUT”).

DESIGNER: In some cases, provide this information to meet specific requirements.

BUILDING CONTRACTOR: Provide this information

UMCS CONTRACTOR: None

D-2.1.8 HOA Required

APPLICABILITY: Any protocol

PURPOSE: Indicates which hardware outputs require HOA switches.

VALID ENTRIES: “Y” to require HOA

DESIGNER: Provide this information

BUILDING CONTRACTOR: Provide HOAs as required

UMCS CONTRACTOR: None – unless monitoring of HOA status is required by specification.

D-2.1.9 Config Type (Configuration Type)

APPLICABILITY: Any protocol

PURPOSE: For points requiring configuration, indicate the type of configuration required for the point

VALID ENTRIES:

- H = Hardware (via switches or adjustments directly on the device).
- C = Configurable
- O or OC = Operator Configurable

(where Configurable and Operator Configurable are defined in the specification)

DESIGNER: Provide this information

BUILDING CONTRACTOR: Provide the appropriate configuration capability in accordance with the specification.

UMCS CONTRACTOR: Provide a means for configuration (such as a configuration page on the system graphic) for each point that is “Operator Configurable” in accordance with the integration requirements.

D-2.1.10 M&C View and Ovrld

APPLICABILITY: Any protocol

PURPOSE: This column indicates whether a point is to be displayed on a workstation via Monitoring and Control (M&C) software, and whether the point must be overridable from the M&C display.

VALID ENTRIES:

- V: View. The point must be displayed on the system graphics
- O: Override. The point must be displayed and overridable via the system graphics
- VO: View and Override. The point must be displayed and overridable via the system graphics (functionally equivalent to “O”)

DESIGNER: Provide an entry for each row

BUILDING CONTRACTOR: For V, expose the point to the network so it will be visible to the UMCS. For O, or VO, provide both the value on the network and an override for the value in accordance with the specification points and override capability. Note that additional columns providing protocol specific point details will need to be filled out as well.

UMCS CONTRACTOR: For V, display the point on the system graphic. For O, or VO, display the value on the system graphic and provide the capability to override the point using the override capability provided by the Building Contractor.

D-2.1.11 LDP View and Ovrld

APPLICABILITY: Any protocol

PURPOSE: This column indicates whether a point is to be displayed on an LDP, and whether the point must be overridable from the LDP.

VALID ENTRIES:

- V: View. The point must be displayed on the LDP
- O: Override. The point must be displayed and overridable via the LDP
- VO: View and Override. The point must be displayed and overridable via the LDP (functionally equivalent to “O”)

DESIGNER: Provide an entry for each row. Note that there may be conflicts if points are overridden from both the M&C software and from an LDP. For Army

projects, do not require overrides from both without specific guidance from the UMCS MCX.

BUILDING CONTRACTOR: For V, display the value on the LDP. For O, or VO, both display the value on the LDP and provide the capability to override the point from the LDP. Note that, depending on how the overrides are implemented, a requirement for Overrides from both the M&C Server and an LDP may require additional configuration in the device as well as additional points in the device and multiple entries in the Points Schedule.

UMCS CONTRACTOR: None

D-2.1.12 Trend Required

APPLICABILITY: Any protocol

PURPOSE: Indicate whether the point should be trended

VALID ENTRIES: “Y”

DESIGNER: Provide this information. Note that all trended points should also have a “V” in the M&C View and Override column.

BUILDING CONTRACTOR: For each point with a “Y” set up a trend in accordance with the specification. Note there is no building contractor action required for in an LNS-based LonWorks system.

UMCS CONTRACTOR: For each point with a “Y”, perform the following in accordance with the specification:

LNS-based LonWorks: Set up a trend

Other: Provide trend data upload capability

All: Provide a M&C Software interface to access the trend information.

D-2.1.13 Alarming: Alarm condition

APPLICABILITY: Any protocol

PURPOSE: Show the conditions under which an alarm occurs, including any time delays.

VALID ENTRIES: The conditions which, when TRUE, will cause an alarm to be generated. See sample drawings for examples.

DESIGNER: Provide this information

BUILDING CONTRACTOR: Perform alarm generation in DDC Hardware in accordance with the specification. Note there is no building contractor action required for in an LNS-based LonWorks system.

UMCS CONTRACTOR:

LNS-based LonWorks: Perform alarm generation in M&C software in accordance with the specification.

Other: None (but note requirements for ALARM PRIORITY and M&C ROUTING columns).

D-2.1.14 Alarming: Alarm priority

APPLICABILITY: Any protocol

PURPOSE: Indicates which alarms are Informational (in alarm until acknowledged or the condition clears itself) and which are Critical (in alarm until acknowledged and the condition clears itself).

VALID ENTRIES: INFO or CRIT

DESIGNER: Provide this information

BUILDING CONTRACTOR: Configure hardware to assign this priority as part of alarm generation. Note there is no building contractor action required for in an LNS-based LonWorks system.

UMCS CONTRACTOR:

LNS-based LonWorks: Configure M&C Software to assign this priority as part of alarm generation.

All: Take appropriate action at M&C Software based on incoming alarm priority.

D-2.1.15 Alarming: M&C routing

APPLICABILITY: Any protocol

PURPOSE: Show the name of the alarm routing group that is to be used for each alarm to be handled by the UMCS. The routing group defines the destinations for each alarm message and, as specified in UMCS UFGS 25 10 10, each group requires some combination of a pop-up message for a user session, an email to one or more individuals, email to SMS for one or more individuals, or printing to one or more printers.

VALID ENTRIES: Name of a valid alarm routing group as defined on UMCS Contract Drawing.

DESIGNER: Provide this information where integration to a UMCS is planned and the alarm routing groups are known. Otherwise, enter “[]” indicating that this information will be provided as part of integration.

BUILDING CONTRACTOR: None

UMCS CONTRACTOR: Provide alarm routing in accordance with the routing definition for that alarm routing group.

D-2.2 Protocol-Specific Columns

D-2.2.1 Primary Point Information: Object Type & Instance Number

APPLICABILITY: BACnet, Niagara BACnet

PURPOSE: Document the BACnet Object used for the point, if any. Any point (except for points only used within Niagara Framework) that is displayed at the front end, displayed on an LDP, is trended, is used by another device on the network, or has an alarm condition must have a BACnet Object associated with it and be documented here.

If the Property of interest is not Present_Value, also document the Property that contains the value (for example, a LOOP Object may use the Setpoint Property). In that case, add the Property Identifier after the Object Type / Instance Number.

VALID ENTRIES: BACnet Object Type and Object Instance Number (e.g. AO-8). Typical Object Types are:

- Analog Input (AI)
- Analog Value (AV)
- Analog Output (AO)
- Binary Input (BI)
- Binary Value (BV)
- Binary Output (BO)
- Multi-state Value (MSV)
- Loop (LOOP)

This is not a complete list of Object Types which may be used. In many cases, the specification and sample drawings require specific points use specific Object Types.

DESIGNER: None

BUILDING CONTRACTOR: Provide this entry.

UMCS CONTRACTOR: Use this information when accessing the point over the network.

D-2.2.2 Primary Point Information: SNVT Name

APPLICABILITY: LNS, Niagara LonWorks

PURPOSE: Document the name of the SNVT used for the point. Any point (except for points only used within Niagara Framework) that is displayed at the front end, displayed on an LDP, is trended, is used by another device on the network, or has an alarm condition must be documented here.

VALID ENTRIES: SNVT Name used by the point.

DESIGNER: None

BUILDING CONTRACTOR: Provide this entry.

UMCS CONTRACTOR: Use this SNVT Name when accessing the point over the network.

D-2.2.3 Primary Point Information: SNVT Type

APPLICABILITY: LNS, Niagara LonWorks

PURPOSE: For any point with an entry in the SNVT Name column, document the SNVT Type used for the point.

VALID ENTRIES: Allowed SNVT Types are generally defined in the specification or on the sample drawings.

DESIGNER: If requiring a specific SNVT Type indicate the Type here.

BUILDING CONTRACTOR: When a SNVT Type is shown, provide a SNVT of the indicated type for the point. Otherwise provide this entry.

UMCS CONTRACTOR: Use this SNVT Type when accessing the point over the network

D-2.2.4 Primary Point Information: Niagara ID

APPLICABILITY: Niagara BACnet, Niagara LonWorks

PURPOSE: List the Niagara station ID of the Niagara Framework Supervisory Gateway that the point is mapped into.

VALID ENTRIES: Valid Niagara Station IDs

DESIGNER: None

BUILDING CONTRACTOR: Provide this information

UMCS CONTRACTOR: Use this information when obtaining data from the control system.

D-2.2.5 Network Data Exchange: Gets Data From and Sends Data To

APPLICABILITY: BACnet, Niagara BACnet

PURPOSE: Document other BACnet devices that this point is shared with. This specifically is for <NET-IN> and <NET-OUT> points, but may include other points as well. Do not include the front end as a possible device, but do include all other DDC Hardware such as LDPs that view or override the point.

BACnet provides multiple methods for data to be exchanged between devices.

Any point with a value that is obtained from other DDC Hardware, regardless of method used, must have an entry in the Gets Data From column. Likewise, any point with data that is provided to other DDC Hardware, regardless of method used, must have an entry in the Sends Data To column.

VALID ENTRIES: DDC Hardware IDs of devices obtaining or providing information with the point. Examples are given below in Points Schedule Application Notes.

DESIGNER: None

BUILDING CONTRACTOR: Provide this entry.

UMCS CONTRACTOR: None.

D-2.2.6 Overrides: Object Type and Instance Number

APPLICABILITY: BACnet, Niagara BACnet

PURPOSE: For any point (except for points within a Niagara Framework Supervisory Gateway) requiring an override, document the Object used for overriding the point

VALID ENTRIES:

- “Commandable”: Indicates that the point’s Object is Commandable (Overridable via use of the Priority Array)
- Object Type and Instance Number: If the point is not Commandable, specify the (other) Object, that when written to, will override the point.

DESIGNER: None

BUILDING CONTRACTOR: Provide this entry.

UMCS CONTRACTOR: Use this information / Object ID when overriding the point over the network.

D-2.2.7 Overrides: SNVT Name

APPLICABILITY: LNS, Niagara LonWorks

PURPOSE: For any point (except for points within a Niagara Framework Supervisory Gateway) requiring an override, document the SNVT used for overriding the point

VALID ENTRIES: SNVT Name of point, that when written to, will override the point

DESIGNER: None

BUILDING CONTRACTOR: Provide this entry.

UMCS CONTRACTOR: Use this SNVT Name when overriding the point over the network.

D-2.2.8 Overrides: SNVT Type

APPLICABILITY: LNS, Niagara LonWorks

PURPOSE: For any point with an entry in the Overrides: SNVT Name column, document the SNVT Type used for overriding the point

VALID ENTRIES: SNVT Type used for overriding the point. Note that UFGS 23 09 23.01 has requirements regarding this SNVT type.

DESIGNER: None

BUILDING CONTRACTOR: Provide this entry.

UMCS CONTRACTOR: Use this SNVT Type when overriding the point over the network.

D-2.2.9 Trend Object Location, Type and Instance Number

APPLICABILITY: BACnet

PURPOSE: Indicates the Object ID of the Trend Log Object and whether the Object is local or remote to the device containing the point.

VALID ENTRIES: “~” when no trend was required, otherwise an “L” or “R” and the Object Type and Instance number for the Trend Log (or Trend Log Multiple) Object. Use “L” (Local) when the Object is in the same device as the point and an “R” (Remote) when it’s in a different device.

DESIGNER: None.

BUILDING CONTRACTOR: Provide this information. If the Trend is Remote, include the DDC Hardware ID for the remote device in the Notes. Configure TrendLog Object and configure BUFFER_FULL event to request trend upload.

UMCS CONTRACTOR: Provide on-request (via BUFFER_FULL Event) uploading of trend data from this Object.

D-2.2.10 Alarm Information: Alarm Type

APPLICABILITY: BACnet, Niagara BACnet

PURPOSE: Indicates how alarm generation is performed.

VALID ENTRIES:

- “Intrinsic”: Alarm is generated using Intrinsic Reporting
- “Local Algorithmic”: Alarm is generated using Algorithmic Reporting with an Event Enrollment Object in that device
- “Remote Algorithmic”: Alarm is generated using Algorithmic Reporting with an Event Enrollment Object in a different device
- “Niagara Framework”: Alarm is generated using the Niagara Framework

Note that “Niagara Framework” is only allowed if the Niagara Framework is used by the project. Note that “Local Algorithmic” and “Remote Algorithmic” are prohibited if the Niagara Framework is selected.

DESIGNER: None

BUILDING CONTRACTOR: Provide this information. When “Local Algorithmic” or “Remote Algorithmic” fill out the Event Enrollment Object Instance Number column as well. If “Remote Algorithmic” is used, indicate the DDC Hardware ID of the device containing the Event Enrollment Object in the Notes.

UMCS CONTRACTOR: None

D-2.2.11 Alarm Information: Notification Class Object Instance Number

APPLICABILITY: BACnet, Niagara BACnet

PURPOSE: For Intrinsic and Algorithmic alarms, indicates the Notification Class Object used for alarm generation.

VALID ENTRIES: Notification Class Object Instance Number

DESIGNER: None

BUILDING CONTRACTOR: Provide as required.

UMCS CONTRACTOR: Use the Notification Class Object when configuring alarm notifications at the Front End.

D-2.2.12 Alarm Information: Event Enrollment Object Instance Number

APPLICABILITY: BACnet

PURPOSE: Indicates the Event Enrollment Object used for algorithmic alarm generation

VALID ENTRIES: Event Enrollment Object Instance Number.

DESIGNER: None

BUILDING CONTRACTOR: Provide as required.

UMCS CONTRACTOR: None

D-2.3 Configuration Information

APPLICABILITY: Any protocol

PURPOSE: Indicate the means of configuration associated with the point

VALID ENTRIES: The valid entries depend on the configuration requirements for the point:

BACnet:

- Operator Configurable Points: BACnet Object and Property information (Name, Type, Identifiers) containing the configurable value. Indicate whether the property is writable always, or only when Out_Of_Service is TRUE.
- Configurable Points: Indicate one of:
 - BACnet Object and Property information as for Operator Configurable points.
 - The configurable settings from within the engineering software for the device
 - The hardware settings on the device

LonWorks:

Indicate one of:

- “Plug-In” if the point is configurable via an LNS plug-in or Niagara Wizard.

- The network variable or configuration property used to configure the value.
- The hardware settings on the device.

Niagara Framework Supervisory Gateways:

Indicate the point within the Niagara Framework Supervisory Gateway used to configure the value.

DESIGNER: None.

BUILDING CONTRACTOR: Provide this information.

UMCS CONTRACTOR: Use this information when providing configuration screens for Operator Configurable points.

D-2.4 Point Schedule Application Notes

D-2.4.1 Use of BACnet “Gets Data From” and “Sends Data To” Columns

Example 1:

- DDC #1 is the controller for a VAV Air Handler.
- DDC #2 is a Smart Sensor reading the supply air pressure (SA-P)
- There is both an AI Object in DDC #2 for Supply Air Pressure, and an AV Object in the AHU controller (DDC #1) for this value. Note that UFGS 23 09 23.02 requires the use of either the AI Object in the sensor or the AV object in the AHU, it does not require the presence of both Objects.
- The relevant entries are highlighted (cells are filled, text is bolded) in the following Points Schedule excerpt:

POINT NAME	DDC HARDWARE ID	IO Type	OBJECT TYPE AND INSTANCE NUMBER (AND PROPERTY ID)	DATA FROM	DATA TO
SF-C	DDC #1	AO	AO 2		
SA-P-SP	DDC #1	~	AV 8		
SA-P	DDC #2	AI, NET-OUT	AI 3		DDC #1
SA-P	DDC #1	NET-IN	AV 9	DDC #2	

Example 2:

- DDC #1 is the controller for a VAV Air Handler.
- DDC #2 is a Smart Sensor reading the supply air pressure (SA-P)
- There is an AI Object in DDC #2 but there is no BACnet Object in DDC #1 for

supply air pressure.

- The appropriate entries are highlighted (cells are filled, text is bolded) in the following Points Schedule excerpt:

POINT NAME	DDC HARDWARE ID	IO Type	OBJECT TYPE AND INSTANCE NUMBER (AND PROPERTY ID)	DATA FROM	DATA TO
SF-C	DDC #1	AO	AO 2		
SA-P-SP	DDC #1	~	AV 8		
SA-P	DDC #2	AI, NET-OUT	AI 3		DDC #1

Example 3:

- DDC #1 is the controller for a VAV Air Handler.
- DDC #2 is a Smart Sensor reading the supply air pressure (SA-P)
- There is NOT an AI Object in DDC #2 for Supply Air Pressure, but there is an AV Object in the AHU controller (DDC #1) for this value.
- The appropriate entries are highlighted (cells are filled, text is bolded) in the following Points Schedule excerpt:

POINT NAME	DDC HARDWARE ID	IO Type	OBJECT TYPE AND INSTANCE NUMBER (AND PROPERTY ID)	DATA FROM	DATA TO
SF-C	DDC #1	AO	AO 2		
SA-P-SP	DDC #1	~	AV 8		
SA-P	DDC #1	NET-IN	AV 9	DDC #2	

APPENDIX E POINT NAMING CONVENTION

E-1 POINT SCHEDULE APPLICATION NOTES.

This appendix defines a point naming convention consisting of abbreviations and acronyms (W-X-Y-Z and ##) that describe the device or signal. Note that a signal can be a hardwired input or output to or from a device as shown in a control schematic or can be a logical constant or variable as shown in a control logic diagram:

- W - Device descriptor; Describes the device, physical location of the device, source of the signal, destination of the signal, or the apparatus/function being controlled. In some cases, a two-part device descriptor is used. For example, MA-FLT is used to describe the mixed air filter.
- X - Measured variable or controlled device; In the case of a sensor or measurement instrument, it is temperature (T), relative humidity (RH), pressure (P), etc. In the case of an output, it can describe the actuated device such as a valve (V) or damper (D).
- Y - Modifier; In some cases, a modifier is required, such as indicating that a signal is a low-limit (LL) or high-limit (HL) input. Alternatively, the modifier may be used to describe the type of control signal such as a modulating command (C), start/stop (SS), enable (ENA), or disable (DIS) signal.
- Z - In some cases, an additional modifier is required, such as indicating that a signal is a setpoint (SP).

- Device or signal number; When there are multiple identical control devices or signals, sequential numbering is used to avoid duplicate unique identifiers. All DDC controllers are numbered (by the Contractor), even if there is only one. The intent is to be able to show a single (common) DDC controller multiple times on a drawing. This can help simplify the control drawings by showing fewer signal lines connected to several DDC controllers instead of showing numerous signal lines connect to a single DDC controller. It also provides leeway to the Contractor to use multiple controllers where project application requirements dictate the need.

E-2 DEVICE DESCRIPTORS.

The following are typical device descriptors (W):

Table E-1 Typical Device Descriptors

Name	Description	Comment
BA	BYPASS AIR	
BLR	BOILER	

Name	Description	Comment
CD	COLD DECK	
CF	CONDENSER FAN	
CHLR	CHILLER	
CLG	COOLING	
CDWR	CONDENSER WATER RETURN	
CDWR	CONDENSATE WATER RETURN	
CDWS	CONDENSER WATER SUPPLY	
CT	COOLING TOWER	
CTF	COOLING TOWER FAN	
CHWR	CHILLED WATER RETURN	
CHWS	CHILLED WATER SUPPLY	
CHW	CHILLED WATER	
DA	DISCHARGE AIR	
DT	DUAL TEMP	
DTWR	DUAL TEMP WATER RETURN	
DTWS	DUAL TEMP WATER SUPPLY	
DX	DIRECT EXPANSION (UNIT)	
EA	EXHAUST AIR	
EF	EXHAUST FAN	

Name	Description	Comment
FAP	FIRE ALARM PANEL	
HD	HOT DECK	
HTG	HEATING	
HTHW	HIGH TEMPERATURE HOT WATER	
HUM	HUMIDIFIER	
HW	HOT WATER	
HWR	HOT WATER RETURN	
HWS	HOT WATER SUPPLY	
HX	HEAT EXCHANGER	
MA	MIXED AIR	
MINOA	MINIMUM OUTSIDE AIR	
OA	OUTSIDE AIR	
PC	PRE-COOLING	
PCHW	PRIMARY CHILLED WATER	
PCHWR	PRIMARY CHILLED WATER RETURN	
PCHWS	PRIMARY CHILLED WATER SUPPLY	
PH	PREHEAT	
PRI	PRIMARY	To distinguish from Secondary
RA	RETURN AIR	
RF	RETURN FAN	
RLA	RELIEF AIR	

Name	Description	Comment
RM	ROOM	Generally, use Zone instead
SA	SUPPLY AIR	
SEC	SECONDARY	To distinguish from Primary
SF	SUPPLY FAN	
STM	STEAM	
SCHD	SCHEDULER	
ZN	ZONE	May use Room instead

E-3 TYPICAL VARIABLES OR CONTROLLED DEVICES.

The following are typical measured variables or controlled devices (X):

Table E-2 Typical Measured Variables or Controller Devices

Name	Description
CO2	CARBON DIOXIDE
D	DAMPER
ECO	ECONOMIZER
F	FLOW
FLT	FILTER
P	PRESSURE
PMP	PUMP
RH	RELATIVE HUMIDITY
SMK	SMOKE
T	TEMPERATURE
V	VALVE

WB	WET BULB (TEMPERATURE)
----	---------------------------

E-4 TYPICAL MODIFIERS.

The following are typical modifiers (Y and Z):

Table E-3 Typical Modifiers

Name	Description	Comment
2P	TWO-POSITION	Indicates a 2-position output
ADJ	ADJUSTABLE	Indicates a value is to be adjustable
ALM	ALARM	Indicates an alarm annunciation point
C	COMMAND	Indicates an analog output
DB	DEADBAND	
DIFF	DIFFERENCE	
DIS	DISABLE	
ENA	ENABLE	
HL	HIGH LIMIT	
LL	LOW LIMIT	
OCC	OCCUPIED	
RQST	REQUEST	
RTN	RETURN	
S	STATUS	
SPLY	SUPPLY	
SP	SETPOINT	

Name	Description	Comment
SS	START/STOP COMMAND	
SYS	SYSTEM	
UNOCC	UNOCCUPIED	

E-5 EXAMPLE POINT NAMES.

For example, here are the standard point names used in the Points Schedule for VAV AHU with Return Fan:

Table E-4 Example Point Names

Name	Description
MINOA-F	MINIMUM OUTSIDE AIR FLOW
MINOA-D-C	MINIMUM OUTSIDE AIR DAMPER COMMAND
MINOA-F-SP	MINIMUM OUTSIDE AIR FLOW SETPOINT (SETTING)
OA-T	OUTSIDE AIR TEMPERATURE
MA-T	MIXED AIR TEMPERATURE
MA-D-C	MIXED AIR DAMPER COMMAND
ECO-HL-SP	ECONOMIZER HIGH LIMIT SETPOINT
ECO-LL-SP	ECONOMIZER LOW LIMIT SETPOINT
MA-T-SP	MIXED AIR TEMPERATURE SETPOINT
SA-T	SUPPLY AIR TEMPERATURE
CLG-V-C	COOLING VALVE COMMAND
SA-T-SP	SUPPLY AIR TEMPERATURE SETPOINT
RA-T	RETURN AIR TEMPERATURE

Name	Description
MA-FLT-P-HL	MIXED AIR FILTER PRESSURE HIGH LIMIT SWITCH
OA-FLT-P	OUTSIDE AIR FILTER PRESSURE
OA-FLT-P-LL	OUTSIDE AIR FILTER PRESSURE LOW LIMIT
SF-S	SUPPLY FAN STATUS
RF-S	RETURN FAN STATUS
SA-SMK	SUPPLY AIR SMOKE
RA-SMK	RETURN AIR SMOKE
CLG-DA-T-LL	COOLING COIL DISCHARGE AIR TEMP LOW LIMIT
SA-P-HL	SUPPLY AIR PRESSURE HIGH LIMIT
RST-BUT	SYSTEM RESET BUTTON (FOR SAFETIES)
SYS-OCC-SCHED	SYSTEM OCCUPANCY SCHEDULE
UNIT STATUS	UNIT STATUS (HTG AND/OR CLG REQUEST) (SEE NOTES)
SYS-OCC-C	OCCUPANCY COMMAND
SYS-OCC	SYSTEM OCCUPANCY (ACTUAL)
SF-SS	SUPPLY FAN START/STOP
RF-SS	RETURN FAN START/STOP
BLDG-T	BUILDING TEMPERATURE (NIGHT STAT)
BLDG-T-LL	BUILDING TEMPERATURE LOW LIMIT
SF-C	SUPPLY FAN COMMAND
SA-P	SUPPLY AIR PRESSURE
SA-P-SP	SUPPLY AIR PRESSURE SETPOINT

Name	Description
SA-F	SUPPLY AIR FLOW
RA-F	RETURN AIR FLOW
RF-C	RETURN FAN COMMAND
F-DIFF-SP	FLOW DIFFERENCE SETPOINT

E-6 OTHER ABBREVIATIONS.

Other Abbreviations that are often encountered in HVAC controls, but would not normally appear in a Point Name in a Point Schedule are:

Table E-5 Other Abbreviations

Name	Description	Comment
AFMA	AIRFLOW MEASUREMENT ARRAY	
BLDG	BUILDING	
BUT	BUTTON	
COM	COMMON	
COMP	COMPARATOR	
COMP	COMPRESSOR	
CP	CONFIGURATION PROPERTY	
CSR	CURRENT SENSING RELAY	
DDC	DIRECT DIGITAL CONTROL(LER)	
DIR	DIRECT (CONTROL ACTION)	
DISP	DISPLAY	
EP	ELECTRIC TO PNEUMATIC TRANSDUCER	
EPS	ELECTRIC TO PNEUMATIC SWITCH	
I/O	INPUT/OUTPUT	

Name	Description	Comment
IR	INFRARED	
LDP	LOCAL DISPLAY PANEL	
M	MOTOR or MAIN	
M&C	MONITORING & CONTROL (SOFTWARE)	
MS	MOTOR STARTER	
N/A	NOT APPLICABLE	
NC	NORMALLY CLOSED	
nci	NETWORK CONFIGURATION INPUT	
NO	NORMALLY OPEN	
ODT	ON DELAY TIMER	
OL	OVERLOAD	
OWS	OPERATOR WORKSTATION	
PID	PROPORTIONAL INTEGRAL DERIVATIVE	
PP	POSITIVE POSITIONER	For pneumatic actuators
R	RELAY	
REV	REVERSE (CONTROL ACTION)	
RST	RESET	
RT	RATE	
SNVT	STANDARD NETWORK VARIABLE TYPE	
STAT	THERMOSTAT	
TAP	TAP, PRESSURE	
VAV	VARIABLE AIR VOLUME	
VFD	VARIABLE FREQUENCY DRIVE	

Name	Description	Comment
XFMR	TRANSFORMER	

This Page Intentionally Left Blank

APPENDIX F CONTROL LOGIC DIAGRAM (CLD) OVERVIEW

F-1 INTRODUCTION

The control logic diagram (CLD) is an unambiguous graphical description of the control system sequence of operation. The focus of the CLD is on control logic, not on a particular hardware implementation. In particular, the CLD does not distinguish between normally open or normally closed contacts, valves, or dampers; these details should instead be indicated on the appropriate wiring diagram, valve/damper schedule, or control schematic drawing. The CLD is concerned with whether a given signal is TRUE or FALSE.

For example, a typical sequence calls for a 'fan status' input (to be used in a fan-proof logic block). The actual hardware could be implemented in a variety of ways, -- a current-sensing-relay on the fan motor, a DP switch across the fan, or an air flow proof switch. The actual hardware used is irrelevant to the CLD. Any one of these possible hardware devices would be shown as a simple binary input to the sequence. Another example would be the freeze stat (CoolinG-Discharge-Air-Temp-LowLimit; CLG-DA-T-LL) which is TRUE when the freeze stat trips; whether that's from a set of NO or NC contacts is a detail for the wiring diagram. Finally, the Controller hardware implementation is not shown; while a given functional block is probably implemented in one controller, a build-up system (such as a RF VAV system with MA Economizer and Ventilation Demand control) may be in one or more controllers – the CLD does not make that distinction.

F-2 FUNCTIONAL BLOCKS USED IN CONTROL LOGIC DIAGRAMS.

In the following descriptions, logical values are always referred to as TRUE or FALSE. Synonyms for these names include ON and OFF, as well as 1 and 0.

F-2.1 Signal.

A line represents a signal path within the logic, either analog or binary. This line shows signal inputs and/or outputs to and from functional blocks.

F-2.2 Actuator Output.

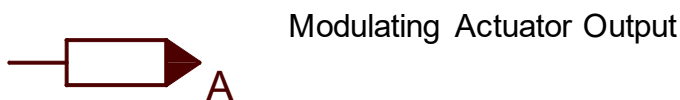
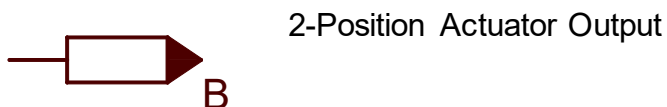

This block represent a physical output from the system, an actuator or valve. It accepts a binary (B) or analog (A) signal and drives a piece of hardware. Since the CLD shows the control logic without reference to the hardware implementation, the actual hardware is unspecified.

F-2.3 Sensor Input.

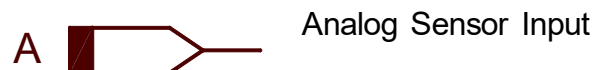

This block represents a hardware sensor input to the system. It may provide either an analog (A) or binary (B) signal. Again, the exact hardware type is unspecified.

F-2.4 Hand-Off-Auto (H-O-A) Switch.

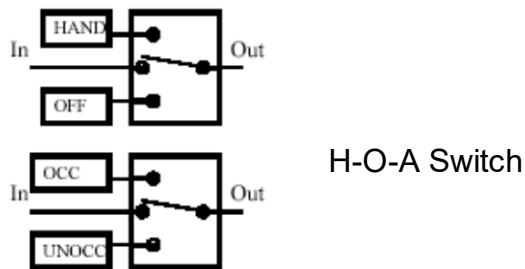

This represents a HAND-OFF-AUTO switch. Sometimes, a H-O-A switch will be shown differently; for example where the position of the H-O-A switch would select some input to control logic. This block is generally used when the output of a control block is selected. The top block shows a normal H-O-A switch, the bottom shows a variant where the manually selected values are OCCUPIED or UNOCCUPIED.

F-2.5 Constant Value.

This logic block represents a constant value, either analog or binary and is usually provided as an input to another logic block.

F-2.6 Signal I/O.



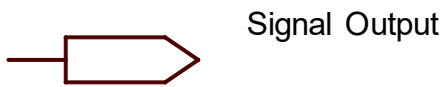

These blocks represent a named signal path within the logic. These are functionally identical to the symbols described earlier, except that this signal is given a name, which allows it to be defined or used elsewhere in the logic.

F-2.7 Logical AND.

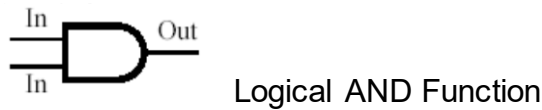

This logic block represents the logical AND function. It takes two or more binary inputs and produces a binary output. Its output is TRUE if and only if all of its inputs are TRUE. If any of its inputs are FALSE, then its output is FALSE.

F-2.8 Logical NOT.



This logic block represents the logical NOT function. It has one binary input and one binary output. Its output is TRUE if and only if its input is FALSE. If its input is TRUE, its output is FALSE.

F-2.9 Logical OR.

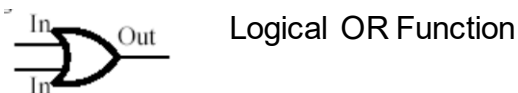

This logic block represents the logical OR function. It has two or more binary inputs and one binary output. Its output is TRUE if any of the inputs are true. If all the inputs are FALSE, the output is FALSE.

F-2.10 On Delay Timer.

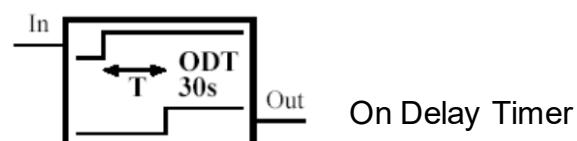

This logic block represents an On Delay Timer. It has one binary input and one binary output. In addition it has one parameter, a time (T) value. The output is always equal to the input, except when the input changes value from FALSE to TRUE. In this case, the transition of the output from FALSE to TRUE is delayed by the value of the time parameter. This time value has no effect on the transition from TRUE to FALSE, it only affects the output when the input becomes TRUE.

F-2.11 Switch.

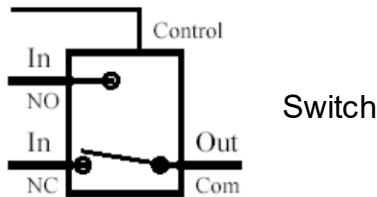

This block represents an analog switch with 2 analog inputs, one analog output, and a binary control input. When the control input is false, the output is the value of the analog signal at the Normally Closed (NC) input. When the control input is true, the output is the value of the analog signal at the NO (Normally Open) input. Note that this convention for NC and NO follows the electrical switch convention; it is opposite from that used for pneumatic switches.

F-2.12 Comparator with Deadband.

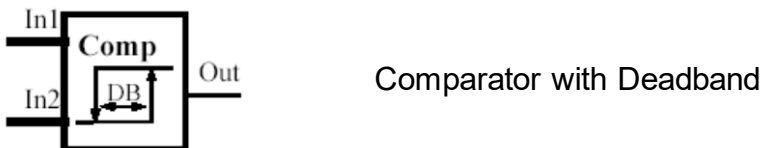

This logic block represents a comparator function with hysteresis. It takes two analog inputs and produces a binary output. It also has one parameter, deadband (DB). As shown in Comparator Table below the output value only changes if the difference between the inputs exceeds half the deadband, if the difference in inputs is less than half the deadband, the output remains at its present value.

Comparator Input and Corresponding Output

Input Conditions	Output Value
$(In1 - In2) < -deadband/2$	FALSE
$-deadband/2 \leq (In1 - In2) \leq deadband/2$	Output does not change; remains fixed
$(In1 - In2) > +deadband/2$	TRUE

For example, if $In1=75$, $In2=68$ and the $deadband=4$, the output would be TRUE. As $In1$ fell, the output would remain TRUE until $In1$ went below 66 ($68 - 66 = 4/2$). Essentially, the output of this block is TRUE if the top value is greater than the bottom value and FALSE if the bottom value is greater than the top value (neglecting the deadband).

F-2.13 Reset Schedule.

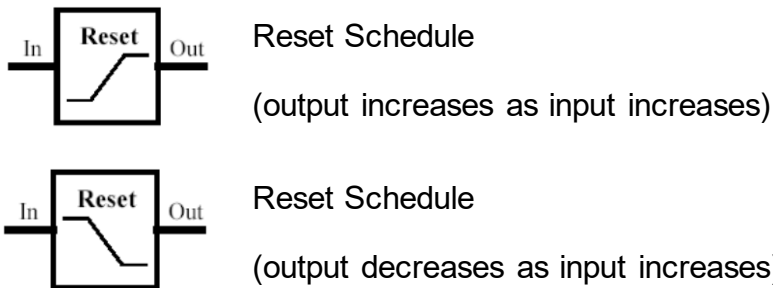

This block represents a reset schedule. It has one analog input, one analog output, and 4 parameters: InputMin, InputMax, OutputMin, and OutputMax. For the first reset schedule shown, the output increases as the input increases; as the input ranges from InputMin to InputMax, the output varies linearly from OutputMin to OutputMax. Inputs below InputMin or above InputMax result in the output going to OutputMin or OutputMax, respectively. For the second reset schedule shown, the output decreases as the input increases. The reset schedule block can be thought of as a graph, with the input variable on the X-axis and the output variable on the Y-axis.

F-2.14 Math Function.

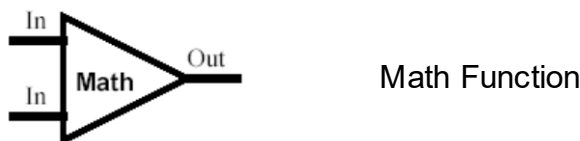

This logic block represents a variety of mathematical functions. It takes two or more analog inputs and produces an analog output. Some common functions for this block are shown in the table below.

Common Math Block Functions

Name	Function
Minus	Subtraction
Minimum	Select the minimum value from the input values
Maximum	Select the maximum value from the input values
Plus	Addition

F-2.15 PID Loop with Enable.

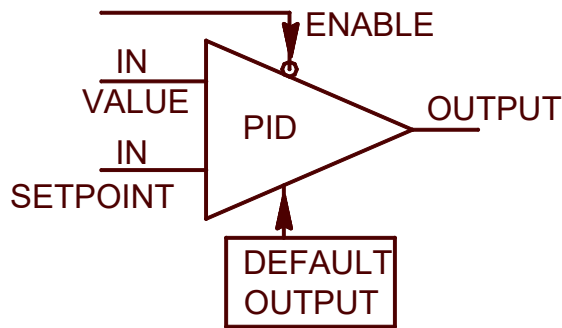

This function block represents a proportional-integral-derivative (PID) loop with an Enable input. It has 2 analog inputs (a value and a setpoint), an analog output, a binary enable input, and default output. The DEFAULT OUTPUT is the OUTPUT when the ENABLE is false.

F-2.16 IF Block.



The IF Block is TRUE if the input meets the condition inside the block, otherwise the IF Block's output is FALSE.

F-2.17 Set/Reset Latch.



This function block represents a latch. The latch has 2 binary inputs, a set input and a reset input, as well as a single binary output. Once set (by a TRUE value at the Set input), the latch's output remains TRUE until reset (by a TRUE value at the reset input). Likewise, once reset, the output remains FALSE until set by a TRUE value at the set input. Essentially, the latch remembers whether it was last Set or Reset.