

FACILITIES CRITERIA (FC)

NAVY AND MARINE CORPS DESIGN PROCEDURES



APPROVED FOR PUBLIC RELEASE; DISTRIBUTION UNLIMITED

FC 1-300-09N
17 May 2024
Change 1, 17 April 2025

This Page Intentionally Left Blank

FACILITIES CRITERIA (FC)

**NAVY AND MARINE CORPS
DESIGN PROCEDURES**

Any copyrighted material included in this FC is identified at its point of use.

Use of the copyrighted material apart from this FC must have the permission of the copyright holder.

Indicate the preparing activity beside the Service responsible for preparing the document.

U.S. ARMY CORPS OF ENGINEERS

NAVAL FACILITIES ENGINEERING SYSTEMS COMMAND (Preparing Activity)

AIR FORCE CIVIL ENGINEER CENTER

Record of Changes (changes are indicated by \1\ ... /1/)

Change No.	Date	Location
1	17 April 2025	Reorganization of Chapter 1 paragraphs; removed AFFF from Chapters 6 and 7; cost changes in Chapter 9; updated para 12-4 and 13-5; mods to B-3.3.1 b,c,d; addressed CCRs; added FRCS consideration for existing buildings; broken weblinks fixed; minor word changes throughout, in accordance with para 7-5.

This FC supersedes FC 1-300-09N, dated May 2014, with Change 6 dated July 2021.

FC 1-300-09N
17 May 2024
Change 1, 17 April 2025

This Page Intentionally Left Blank

FOREWORD

Facilities Criteria (FC) provide functional requirements (i.e., defined by users and operational needs of a particular facility type) for specific DoD Component(s), and are intended for use with unified technical requirements published in DoD Unified Facilities Criteria (UFC). FC are applicable only to the DoD Component(s) indicated in the title, and do not represent unified DoD requirements. Differences in functional requirements between DoD Components may exist due to differences in policies and operational needs.

All construction outside of the United States is also governed by Status of Forces Agreements (SOFA), Host Nation Funded Construction Agreements (HNFA), and in some instances, Bilateral Infrastructure Agreements (BIA). Therefore, the contracting team must ensure compliance with the most stringent of the FC, the SOFA, the HNFA, and the BIA, as applicable.

Because FC are coordinated with unified DoD technical requirements, they form an element of the DoD UFC system applicable to specific facility types. The UFC system is prescribed by MIL-STD 3007 and provides planning, design, construction, sustainment, restoration, and modernization criteria, and applicable to the Military Departments, Defense Agencies, and the DoD Field Activities in accordance with [USD \(AT&L\) memorandum](#) dated 29 May 2002. The UFC System also includes technical requirements and functional requirements for specific facility types, both published as UFC documents and FC documents.

FC are living documents and will be periodically reviewed, updated, and made available to users as part of the Services' responsibility for providing criteria for military construction. Headquarters, U.S. Army Corps of Engineers (HQUSACE), Naval Facilities Engineering Systems Command (NAVFAC), and the Air Force Civil Engineer Center (AFCEC) are responsible for administration of the UFC system. Defense agencies should contact the preparing service for document interpretation and improvements. Technical content is the responsibility of the cognizant DoD working group. Recommended changes with supporting rationale should be sent to the respective service proponent office by the following electronic form: [Criteria Change Request](#). The form is also accessible from the Internet site listed below.

FC are effective upon issuance and are distributed only in electronic media from the following source:

- Whole Building Design Guide website <https://www.wbdg.org/dod>.

Refer to UFC 1-200-01, *DoD Building Code*, for implementation of new issuances on projects.

AUTHORIZED BY:

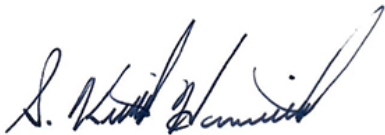

S. Keith Hamilton, P.E.

Chief Engineer and Assistant Commander for Planning, Design and Construction n
Naval Facilities Engineering Systems Command (NAVFAC)

FC 1-300-09N
17 May 2024
Change 1, 17 April 2025

This Page Intentionally Left Blank

TABLE OF CONTENTS

CHAPTER 1 INTRODUCTION	1
1-1 REISSUES AND CANCELS.....	1
1-2 PURPOSE AND SCOPE.....	1
1-2.1 Organization of Document.....	1
1-3 APPLICABILITY.....	1
1-4 GENERAL BUILDING REQUIREMENTS.....	2
1-5 CYBERSECURITY.....	2
1-6 EXCEPTIONS.....	2
1-7 GLOSSARY.....	2
1-8 REFERENCES.....	2
CHAPTER 2 POLICY.....	3
2-1 CRITERIA.....	3
2-2 METRIC POLICY.....	3
2-2.1 SI Definitions.....	3
2-2.2 General Policy.....	3
2-3 OWNERSHIP OF PROJECT DOCUMENTS AND DATA.....	4
2-4 OPERATION SECURITY (OPSEC).....	4
2-4.1 OPSEC Review.....	4
2-4.2 Mission Information.....	4
2-4.3 Information Compilation.....	4
2-4.4 Sensitive or Critical Information.....	4
2-5 REGISTRATION.....	5
2-5.1 Certification.....	6
2-6 PROHIBITION OF POSTING CONTROLLED UNCLASSIFIED INFORMATION DESIGN DELIVERABLES ON UNSECURED SERVERS. 	6
2-7 DESIGN DELIVERABLES FOR NAVAL CONSTRUCTION FORCES - MARINE LOGISTICS GROUPS AND NAVY CONSTRUCTION BATTALIONS (SEABEES).....	6
2-8 OVERSEAS LOCATIONS TRANSLATIONS.....	6
CHAPTER 3 ROLES AND RESPONSIBILITIES.....	7
3-1 DESIGNER OF RECORD (DOR).....	7

3-1.1	Coordination with Command, Major Claimant, Region, and Activity.	7
3-1.2	Coordination with Other Government Organizations.	7
3-1.3	Document Review and Checking System.	7
3-1.4	Response to Review Comments.	7
3-1.5	Final Approval.	8
3-2	OTHER GOVERNMENT ORGANIZATIONS.	8
3-2.1	Commander, 1st Naval Construction Division.	8
3-2.2	Reviews for Health Hazards During Facilities Design Process.	8
3-2.3	Naval Information Warfare Center (NIWC).	8
3-2.4	Civil Works.	8
3-2.5	Historic Preservation Compliance.	9
3-2.6	Overseas Cultural Resources.	9
3-2.7	NAVFAC Medical Facilities Design Office (MFDO).	9
3-2.8	Sensitive Compartmented Information Facilities (SCIF) and Special Access Program Facilities (SAPF).	9
3-3	COMMANDER, NAVFAC.	9
CHAPTER 4 DELIVERABLE: FIELD INVESTIGATION		11
4-1	PURPOSE AND SCOPE.	11
4-2	RESPONSIBILITIES.	11
4-3	COORDINATION.	11
4-4	TOPOGRAPHIC SURVEY.	12
4-5	GEOTECHNICAL INVESTIGATIONS AND REPORT.	13
4-5.1	Existing Information.	13
4-5.2	Foundation and Soils Investigation.	14
4-5.3	Geotechnical Report.	15
4-5.4	Boring Logs.	16
4-5.5	Foundation and Site Preparation.	16
4-5.6	Airfield Pavement Evaluations.	16
4-6	FIRE PROTECTION INVESTIGATIONS AND SURVEY.	16
4-6.1	Utilities and Infrastructure.	16
4-6.2	Site and Building Surveys.	18
4-7	ENVIRONMENTAL REQUIREMENTS.	19
CHAPTER 5 DELIVERABLE: BASIS OF DESIGN.		21

5-1	GENERAL REQUIREMENTS.	21
5-2	FORMAT.	21
5-3	KEY PROJECT CONTACTS.	22
5-4	BIM PROJECT EXECUTION PLAN (PXP).	22
5-5	SUSTAINABILITY.	22
5-5.1	Guiding Principles Validation.	23
5-5.2	Pre-award Commissioning Services.	23
5-6	ANTITERRORISM (AT).	23
5-7	GEOTECHNICAL.	23
5-8	CIVIL.	24
5-8.1	Existing Conditions.	24
5-8.2	Demolition.	24
5-8.3	Site Work.	24
5-8.4	Water Supply.	25
5-8.5	Sanitary Sewer.	25
5-8.6	Wastewater Treatment.	25
5-8.7	Storm Drainage System.....	26
5-8.8	Stormwater Management.....	26
5-8.9	Erosion & Sediment Control.....	26
5-8.10	Permits.....	26
5-9	STRUCTURAL.	26
5-10	FIRE PROTECTION.	27
5-10.1	Project Summary.	27
5-10.2	Building Code Analysis.	28
5-10.3	Life Safety Code Analysis.	28
5-10.4	Water Supply Analysis.	28
5-10.5	Hydraulic Demand Analysis.	29
5-10.6	Active Fire Protection Features.....	29
5-10.7	Host Nation Requirements.....	30
5-11	CYBERSECURITY.	30
CHAPTER 6 DELIVERABLE: CALCULATIONS		33
6-1	GENERAL REQUIREMENTS.	33

6-2	COMPUTER GENERATED CALCULATIONS.....	33
6-3	FORMAT.	33
6-4	SUSTAINABILITY AND ENERGY.	33
6-5	GEOTECHNICAL REQUIREMENTS.	33
6-6	CIVIL.....	33
6-6.1	Low Impact Development (LID).	34
6-7	STRUCTURAL REQUIREMENTS.	34
6-7.1	Calculations and Test Reports for Antiterrorism.	35
6-7.2	Design for Lateral Forces.....	36
6-7.3	Computer Generated Calculations.....	36
6-8	FIRE PROTECTION CALCULATIONS.....	36
6-8.1	Hydraulic Demand Analysis.	36
6-8.2	Fire Pumps.	37
6-8.3	Special Systems.	37
6-8.4	Fire Alarm/Detection and Reporting Systems.....	38
CHAPTER 7 DELIVERABLE: DRAWINGS.....		39
7-1	GENERAL REQUIREMENTS.	39
7-2	BUILDING INFORMATION MANAGEMENT AND MODELING (BIM). ..	39
7-3	PRESENTATION.....	39
7-4	DRAWING NUMBERS.	40
7-5	PROPER USE OF NOTES ON DRAWINGS.....	40
7-6	CODE COMPLIANCE SUMMARY SHEET(S).	42
7-6.1	Building Code Site Plan.	42
7-6.2	Building Code Summary.	42
7-6.3	Life Safety Code® Summary.	43
7-6.4	Life Safety Plans.....	43
7-7	CIVIL DRAWINGS.....	44
7-7.1	Cover Sheet, Drawing Index, Vicinity Map, Location Plan, Abbreviations, Legend, and Notes, or First Civil Sheet.....	44
7-7.2	Demolition Plan.....	45
7-7.3	Site Plan.	46
7-7.4	Water and Sanitary Sewer Plan.....	46
7-7.5	Water, Storm, and Sanitary Sewer Profiles.....	47

7-7.6	Grading and Drainage Plan.	48
7-7.7	Site / Utility Details.	48
7-8	LANDSCAPE ARCHITECTURAL DRAWINGS.	49
7-8.1	Landscape Demolition Plan.	49
7-8.2	Landscape Site Plan.	49
7-8.3	Landscape Construction Details.	49
7-8.4	Landscape Planting Plan.	49
7-8.5	Plant Material Schedule and Details.	50
7-8.6	Landscape Irrigation Plan.	50
7-8.7	Irrigation Equipment Schedule and Details.	50
7-9	GEOTECHNICAL DRAWINGS.	50
7-10	STRUCTURAL DRAWINGS AND NOTES.	51
7-11	FIRE PROTECTION.	51
7-11.1	Fire Sprinkler Systems.	52
7-11.2	Gaseous Fire Extinguishing Systems.	52
7-11.3	Fire Suppression Detail Sheets.	52
7-11.4	Fire Alarm/Mass Notification System Plans.	53
7-11.5	Fire Alarm/Mass Notification System Detail Sheets.	54
7-12	DRAWINGS PREPARED FOR OTHER GOVERNMENT ORGANIZATIONS.	54
CHAPTER 8	DELIVERABLE: SPECIFICATIONS.	57
8-1	GENERAL REQUIREMENTS.	57
8-2	GUIDE SPECIFICATIONS.	57
8-2.1	Unified Facilities Guide Specifications (UFGS).	57
8-2.2	Regional Guide Specifications.	58
8-2.3	Other Guide Specifications.	58
8-2.4	UFGS Selection Order of Precedence.	58
8-2.5	DB Performance Technical Specifications.	59
8-3	PROJECT PREPARATION POLICIES AND GUIDANCE.	59
8-3.1	UFGS Version Date.	59
8-3.2	Editing of Specifications for Project.	59
8-3.3	Standard Plates, Sketches, and Details.	59
8-3.4	Unrestricted Bidding.	59

8-3.5	Contract Parties.	60
8-3.6	Facilities Electronic Operation and Maintenance Systems Information (eOMSI).	60
8-4	COORDINATION OF SPECIFICATIONS AND DRAWINGS.	60
8-4.1	DBB Contract Order of Precedence.....	60
8-4.2	DB Contract Order of Precedence.....	60
8-4.3	Coordination.	60
8-5	USE OF UFGS AND SPECSINTACT.....	61
8-6	SPECIFICATIONS PACKAGE ORGANIZING STRUCTURE.	61
8-6.1	Coversheet.	61
8-6.2	Contract Documents.	61
8-6.3	Format.	61
8-6.4	General Requirements (Division 00 and 01) Specifications.....	61
8-6.5	DB RFP.....	63
8-6.6	Project Reports.	64
8-6.7	Combining Multiple Projects into One Bid Package.....	64
CHAPTER 9	DELIVERABLE: COST ESTIMATES	69
9-1	GENERAL REQUIREMENTS.	69
9-2	COST ESTIMATE CLASS STANDARDS.	69
9-3	COST ESTIMATE DEVELOPMENT REQUIREMENTS.....	70
9-3.1	Level of Detail.	70
9-3.2	Labor Costs	70
9-3.3	Local Pricing for Projects OCONUS	70
9-3.4	Escalation.	71
9-3.5	Job Office Overhead (JOOH).....	72
9-3.6	Markup Requirements.	72
9-3.7	Development of Specific Task.	73
9-4	SENSITIVITY ANALYSIS.....	73
9-5	COST AND SCHEDULE RISK ANALYSIS (CSRA).	73
9-5.1	Budgeting CSRA.....	74
9-5.2	Design CSRA.....	74
9-5.3	Construction CSRA.....	74
9-5.4	Schedule Risk.....	74

9-6	VALUE ENGINEERING STUDIES (VES)	74
9-7	INDEPENDENT COST ESTIMATE (ICE)	74
9-7.1	Reconciliation.	75
9-7.2	Documentation.....	75
9-8	CONSTRUCTION SCHEDULE	76
9-8.1	Construction Schedule Class Standards.....	76
9-8.2	Construction Schedule Development Requirements.	76
9-8.3	Cost-Loaded Construction Schedule.	77
9-9	SUBMITTAL REQUIREMENTS	77
CHAPTER 10	DELIVERABLE: CONTRACTING REQUIREMENTS	81
10-1	GENERAL REQUIREMENTS	81
10-2	PROJECT INFORMATION FORM (PIF)	81
10-3	SELECTION OF LINE ITEMS	81
10-4	OPTIONS AND ADDITIVES	82
10-5	OPTION ITEMS	82
10-6	ADDITIVE ITEMS	82
10-7	DEDUCTIVE ITEMS	82
CHAPTER 11	DELIVERABLE: DB REQUEST FOR PROPOSAL (RFP)	83
11-1	GENERAL REQUIREMENTS	83
11-2	DB REQUEST FOR PROPOSAL INTRODUCTION	83
11-3	DB REQUEST FOR PROPOSAL WEBSITE, FORMAT, AND DOCUMENTS	84
11-3.1	RFP Format.	85
11-3.2	Recommend Change to DB Documents.....	86
11-4	DB REQUEST FOR PROPOSAL DOCUMENT PREPARATION	86
11-4.1	Combining Multiple RFPs into One Bid Package.....	86
11-4.2	Project Information Form (PIF).	86
11-5	RFP ELECTRONIC DELIVERABLES	86
11-6	DB DESIGN SUBMITTALS	87
11-7	DESIGN AND CONSTRUCTION SUBMITTAL REQUIREMENTS	87
11-7.1	Locations of DB Submittal Requirements.	87
11-7.2	Government Approval and Surveillance of DB Submittals.....	88
CHAPTER 12	ELECTRONIC DESIGN DELIVERABLES (EDD) FORMAT	91

12-1	SUMMARY.....	91
12-2	EDD.....	91
12-3	EDD FORMAT REQUIREMENTS.....	92
12-3.1	Specifications.....	92
12-3.2	Electronic Operation and Maintenance Support Information (eOMSI) Facility Data Workbook (FDW).....	92
12-3.3	Drawings.....	92
12-3.4	Preliminary Design Documents.....	99
12-3.5	Final Design Documents.....	99
12-3.6	Record Documents.....	101
12-3.7	NAVFAC Supported EDD Standard Components.....	103
12-4	NAVFAC ELECTRONIC SIGNATURE REQUIREMENTS.....	104
12-4.1	General Requirements.....	104
12-4.2	Specific Software Requirements.....	105
12-4.3	Wet-Signed Documents.....	105
12-5	BUILDING INFORMATION MANAGEMENT/MODELING (BIM) REQUIREMENTS.....	106
12-5.1	BIM Definitions.....	106
12-5.2	Minimum Modeling and Data Requirements.....	107
12-5.3	Design Model.....	108
12-5.4	Record Model.....	108
12-5.5	Drawing and Model Progression.....	109
12-5.6	BIM Submittal Requirements.....	110
12-6	EDD MEDIA AND ORGANIZATION.....	110
12-6.1	General.....	110
12-6.2	Minimum Final Submittal Requirements.....	111
12-6.3	Minimum Record Drawing Submittal Requirements.....	112
CHAPTER 13 PHASE: PRELIMINARY DESIGN: DON MILCON.....		113
13-1	GENERAL REQUIREMENTS.....	113
13-2	PRELIMINARY DESIGN.....	113
13-3	PROJECT PLANNING DD FORM 1391 ASSESSMENT.....	113
13-4	ROLES AND RESPONSIBILITIES.....	113
13-5	PRELIMINARY DESIGN DOCUMENTATION.....	114

13-5.1	Preliminary Design Element.....	114
13-5.2	Preliminary Design File Naming Convention.....	115
13-6	PRELIMINARY DESIGN CHARETTE.....	117
13-6.1	Format.	117
13-6.2	Participation.....	117
13-7	IDENTIFICATION OF UNIQUE PROJECT REQUIREMENTS.....	117
13-8	DD FORM 1391.....	118
13-9	PRELIMINARY PROJECT NARRATIVE.	118
13-9.1	Description of Proposed Construction.	119
13-9.2	Project Objectives.....	119
13-9.3	Site Analysis.	119
13-9.4	Building Requirements.....	119
13-9.5	Host Nation Requirements.....	119
13-10	DISCIPLINE-SPECIFIC BASIS OF DESIGN.	119
13-10.1	Building Systems.	120
13-10.2	Site.	120
13-10.3	Cybersecurity Impact Level.....	120
13-10.4	Ratio of Renovation Cost to Replacement Cost.....	120
13-10.5	Narratives.	120
13-11	PRELIMINARY DRAWINGS.	121
13-12	COST ESTIMATE.....	122
13-13	SITE ENGINEERING INVESTIGATION.....	122
13-13.1	Utility Investigation.....	123
13-13.2	Subsurface/Geotechnical Investigations.....	123
13-13.3	Topographic Survey.....	123
13-13.4	Existing Building Surveys.....	124
13-13.5	Hazardous Materials Investigation.....	124
13-13.6	Building Code Assessment of Adjacent Structures.....	125
13-14	CALCULATIONS.	125
13-14.1	Plumbing.....	125
13-14.2	Mechanical.....	125
13-14.3	Fire Protection.	126

CHAPTER 14 PHASE: SCHEMATIC DESIGN SUBMITTALS (10-15%).....	127
14-1 GENERAL REQUIREMENTS.	127
14-2 DB SCHEMATIC DESIGN SUBMITTAL.	127
14-3 BASIS OF DESIGN.	127
14-3.1 Geotechnical.....	127
14-3.2 Sustainability.....	127
14-3.3 Cybersecurity.....	127
14-4 DRAWINGS.	128
14-4.1 Architectural.....	128
14-4.2 Civil.	128
14-4.3 Landscape Architecture.	128
14-4.4 Electrical.	128
14-4.5 Fire Protection.	129
14-4.6 Geotechnical.....	129
14-5 BIM PXP.	129
14-6 CALCULATIONS.	129
14-7 SUSTAINABILITY.	129
14-7.1 TPC Registration.	129
14-8 CHARETTES AND FUNCTIONAL ANALYSIS CONCEPT DEVELOPMENT (FACD) STUDIES.....	130
14-8.1 Description.....	130
CHAPTER 15 PHASE: DESIGN DEVELOPMENT SUBMITTALS (35% - 50%).....	131
15-1 GENERAL REQUIREMENTS.	131
15-2 BASIS OF DESIGN.	131
15-2.1 Sustainability.....	131
15-3 DRAWINGS.	131
15-3.1 Architectural.....	131
15-3.2 Interior Design.	132
15-3.3 Landscape Architecture.	132
15-3.4 Geotechnical.....	132
15-3.5 Civil.	132
15-3.6 Structural.	133
15-3.7 Mechanical.....	133

15-3.8	Electrical.....	134
15-3.9	Fire Protection.....	134
15-4	BIM DESIGN MODEL.....	134
15-5	OUTLINE SPECIFICATIONS.....	134
15-5.1	eOMSI Facility Data Workbook (FDW).....	135
15-6	CALCULATIONS.....	135
15-6.1	Structural and Geotechnical.....	135
15-6.2	Civil.....	135
15-6.3	Architectural.....	135
15-6.4	Mechanical.....	135
15-6.5	Electrical.....	136
15-6.6	Fire Protection.....	136
15-6.7	Environmental Report.....	136
15-7	QUALITY CONTROL (QC) REVIEW AND DOCUMENTATION.....	136
15-7.1	Review.....	136
15-7.2	Documentation.....	137
CHAPTER 16	PHASE: PRE-FINAL DESIGN SUBMITTALS (100%).....	139
16-1	GENERAL.....	139
16-2	BASIS OF DESIGN.....	139
16-2.1	Geotechnical.....	139
16-2.2	Sustainability.....	139
16-3	DRAWINGS.....	139
16-3.1	Civil.....	139
16-3.2	Landscape Architecture.....	140
16-3.3	Electrical.....	140
16-4	BIM DESIGN MODEL.....	141
16-5	SPECIFICATIONS.....	141
16-5.1	Sustainability.....	141
16-5.2	Environmental.....	141
16-5.3	eOMSI Facility Data Workbook.....	141
16-6	CONTRACT SOLICITATION.....	141
16-7	INTERIOR DESIGN.....	142

16-7.1	Structural Interior Design (SID).....	142
16-7.2	FF&E.....	142
16-8	CALCULATIONS.	142
16-8.1	Mechanical.....	142
16-8.2	Electrical.	143
16-9	STATEMENT OF SPECIAL INSPECTIONS.	143
16-10	DRAFT DD FORM 1354.	143
16-11	FACILITY RECOGNITION PLAQUE.....	143
16-12	DB RFP DEVELOPMENT.	144
16-13	OVERSEAS TRANSLATIONS.....	144
16-14	QUALITY CONTROL (QC) REVIEW AND DOCUMENTATION.	144
16-14.1	Review.....	144
16-14.2	Documentation.....	144
CHAPTER 17 PHASE: FINAL DESIGN SUBMITTALS		145
17-1	GENERAL REQUIREMENTS.	145
17-2	BASIS OF DESIGN.	145
17-2.1	Geotechnical.....	145
17-3	SUSTAINABILITY.	145
17-3.1	TPC Design Review.....	145
17-4	DRAWINGS.....	145
17-4.1	Plotstamp Record.	146
17-4.2	DB Shop Drawings.	146
17-5	BIM DESIGN MODEL.....	146
17-6	SPECIFICATIONS.....	146
17-6.1	eOMSI Facility Data Workbook.....	147
17-6.2	Sustainability.....	147
17-6.3	Environmental.....	147
17-6.4	DB Design Submittal Specifications.....	147
17-6.5	Report Source File.....	147
17-7	CONTRACTING DOCUMENTS.	147
17-8	INTERIOR DESIGN.....	147
17-8.1	Structural Interior Design (SID).....	147

17-8.2	FF&E.....	148
17-9	CALCULATIONS.	148
17-10	DRAFT FORM DD 1354.	148
17-11	STATEMENT OF SPECIAL INSPECTIONS.	148
17-12	RFP.....	148
17-12.1	Report Source File.....	149
17-13	FIRE PROTECTION DESIGN COMPLIANCE DOCUMENT.....	149
17-14	QUALITY CONTROL (QC) REVIEW AND DOCUMENTATION.	149
17-14.1	Review.....	149
17-14.2	Documentation.....	149
17-14.3	DB Quality Control.....	150
17-14.4	Code Compliance Certification.....	150
17-14.5	Host Nation Life Safety/Building Code Compliance Documentation..	150
17-14.6	Geotechnical Report Translation.....	151
CHAPTER 18 PHASE: POST-DESIGN OR POST-RFP DEVELOPMENT SUBMITTAL REQUIREMENTS		153
18-1	GENERAL REQUIREMENTS.	153
18-2	PRE-PROPOSAL AND REQUESTS FOR INFORMATION.....	153
18-3	CHANGE NUMBERS OR LETTERS.....	153
18-4	COST ESTIMATE CHANGES.....	153
18-5	CHANGE FORMAT.....	153
18-5.1	Continuation Sheet, Modification, and Language Format.....	154
CHAPTER 19 PHASE: POST-CONSTRUCTION DOCUMENTS.....		157
19-1	PROJECT CLOSE-OUT.....	157
19-1.1	Interim Form DD 1354.....	157
19-1.2	Record Drawings.....	157
19-1.3	BIM Final Record Model.....	157
19-1.4	Sustainability.....	157
APPENDIX A SAMPLE DELIVERABLES.....		159
A-1	PRICE SCHEDULE FORM FOR DBB PROJECT	159
A-2	SAMPLE SYNOPSIS.....	163
APPENDIX B COST ESTIMATE CLASSIFICATION AND VALUE ENGINEERING STUDY REQUIREMENTS		165

B-1	INDUSTRY COST ESTIMATE CLASSIFICATION.	165
B-2	PRELIMINARY DESIGN COST ESTIMATE.	169
B-3	VALUE ENGINEERING STUDY (VES) REQUIREMENTS.	173
B-3.1	VE/VA Team Requirements.	173
B-3.2	VES Kick Off Meeting.	173
B-3.3	Value Engineering Workshop (VEW).	173
B-4	VES DECISION/IMPLEMENTATION MEETING.	175
B-5	VES REPORT.	176
APPENDIX C BIM (MODELING)		177
C-1	BIM - BASIS OF DESIGN SAMPLE TABLES.	177
C-2	QUALITY CONTROL CHECKS.	180
C-2.1	Overall Strategy for Quality Control.	180
C-2.2	Quality Control Checks.	180
APPENDIX D GLOSSARY		181
D-1	ACRONYMS.	181
APPENDIX E REFERENCES		185
E-1	GOVERNMENT	185
E-2	NON-GOVERNMENT	188

FIGURES

Figure 8-1	Sample Table of Contents for Combined DBB Projects.....	65
Figure 8-2	Sample Combined DB and DBB Project	67
Figure 12-1	Drawing Progression Chart DBB.....	94
Figure 12-2	Drawing Progression Chart DB	94
Figure 12-3	Model Files	97
Figure 12-4	Sheet Files.....	97
Figure 12-5	File Naming Convention for Final Design PDF Files.....	101
Figure 12-6	Record Drawing Stamp Example.....	102
Figure 12-7	Record CAD Files	103
Figure 12-8	NAVFAC Signatures	105
Figure 12-9	BIM Design Model Naming Convention	108
Figure 12-10	Record Model Naming Convention.	109
Figure 12-11	Drawing and Model Progression DBB	109
Figure 13-1	Preliminary Design File Naming Convention	115
Figure 17-1	Quality Review Block.....	149
Figure 17-2	Code Compliance Certification.....	150
Figure 18-1	Sample Amendment/Modification	155

TABLES

Table 7-1	BIM and FDW Requirements.....	39
Table 8-1	Commonly Used DBB UFGS Division 00 and 01 Sections.....	62
Table 8-2	Commonly Used DB RFP PART Two UFGS Division 01 Sections.....	63
Table 9-1	Cost Estimate Classification by Project Phase.....	69
Table 9-2	MII Template Project Items Crosswalk.....	71
Table 9-3	\1V1/Activity Detail by Schedule Class.....	77
Table 11-1	Design and Construction Submittal Summary.....	88
Table 12-1	Facility Types and I.D. Designators	98
Table 13-1	Element Extensions and Examples.....	116
Table 13-2	MILCON Checklist File Naming Conventions.....	116
Table B-1	Cost Estimate Class Comparison from AACE RP 56-08.....	165
Table B-2	Minimum Project Data and Deliverables.	169

Table C-1 Key Project Contacts	177
Table C-2 Major BIM Goals and Objectives.....	178
Table C-3 BIM Uses	179
Table C-4 Organizational Roles and Staffing	179
Table C-5 Quality Control Checks.....	180

CHAPTER 1 INTRODUCTION

1-1 REISSUES AND CANCELS.

This FC reissues FC 1-300-09N, \1\ dated 1 May, 2014, with Change 6 dated 9 July 2021. /1/

1-2 PURPOSE AND SCOPE.

This FC provides policy and standards for planning, design, development, and revision of project documents, including drawings, specifications, and Requests for Proposal, for facilities under the cognizance of NAVFAC. This FC has been developed to ensure consistency and clarity of project documents that form the basis of contracts for planning, design, and construction of facilities. \1\ Use this FC for projects where NAVFAC is the construction agent, as defined in DoDD 4270.5, for preparation of construction contract drawings, specifications, and Request for Proposals for shore facilities, for both Design-Bid-Build (DBB) and Design-Build (DB) projects. The Design and Submittal procedures contained herein are pertinent to standards, software, and templates used, required, and unified within NAVFAC, and centered around the NAVFAC organization and operation. Procedures for NAVFAC may not work for USACE and Air Force operations due to organizational and operational differences. /1/

1-2.1 Organization of Document.

This document is organized into design policy, roles and responsibilities, design deliverables, and design phases. The design deliverables chapters contain general requirements that apply throughout the design process. For the disciplines, additional information is provided only if it is not already in another UFC; thus, a discipline paragraph may not be provided if the Core UFC already provides the requirements for that deliverable, or the level of completion of that deliverable. Core UFCs are defined and listed in UFC 1-200-01.

Detailed level of completion for each type of submittal, and for each discipline, only beyond what is specified in other UFCs, are included in each design phase.

This FC provides specific guidance on how and when to provide a project design deliverable for NAVFAC. This document is organized into design deliverables and design phases. Requirements for design deliverables, beyond or in more detail of what is already required by a Core UFC, are provided for NAVFAC-only. The requirements for when or to what extent these deliverables are provided are in the Phase chapters.

1-3 APPLICABILITY.

\1\ This FC follows the same applicability as UFC 1-200-01, paragraph 1-3, with no exceptions. /1/.

1-4 GENERAL BUILDING REQUIREMENTS.

Comply with UFC 1-200-01, *DoD Building Code* and UFC 1-200-02 *High Performance and Sustainable Building Requirements*. Use 1-200-02 in conjunction with UFC 1-200-01 and the UFC and government criteria referenced therein. UFC 1-200-01 provides applicability of model building codes and government unique criteria for typical design disciplines and building systems, as well as for accessibility, antiterrorism, physical security, cybersecurity, high performance and sustainability requirements, and safety. UFC 1-200-02 provides minimum unified requirements and coordinating guidance for planning, designing, constructing, renovating, and maintaining high performance and sustainable facilities that will enhance DOD mission capability by reducing total ownership costs. Use this FC in addition to UFC 1-200-01, UFC 1-200-02, and the UFC and government criteria referenced therein.

1-5 CYBERSECURITY.

Plan, design, acquire, execute, and maintain facility-related control systems (FRCS) (including systems separate from a utility monitoring and control system) in accordance with UFC 4-010-06, and when required by individual Service Implementation Policy.

1-6 EXCEPTIONS.

Austere Requirements may be invoked on a per-project basis, and only by formal letter from Commander, Naval Installations Command (CNIC). Austere requirement options are included in FC 4-721-10N, UFC 4-610-01, UFC 4-722-01, and UFC 4-740-02.

1-7 GLOSSARY.

APPENDIX D contains acronyms, abbreviations, and terms.

1-8 REFERENCES.

APPENDIX E contains a list of references used in this document. The publication date of the code or standard is not included in this document. Unless otherwise specified, the most recent edition of the referenced publication applies.

CHAPTER 2 POLICY

2-1 CRITERIA.

Design Naval shore facilities in accordance with Navy and Department of Defense (DoD) Criteria. DoD Design Criteria are available from the Whole Building Design Guide (WBDG) (<https://www.wbdg.org/dod>). Design criteria include general criteria, as well as specific criteria on particular elements of the work (such as Geotechnical Engineering) and facility types (such as Bachelor Quarters). Design requirements are typically in the form of Unified Facilities Criteria (UFC). The contract will reference the specific requirements applicable to a particular project. Deviations from criteria must be approved by the NAVFAC Chief Engineer and in accordance with MIL-STD-3007.

2-2 METRIC POLICY.

Comply with MIL-STD-3007 for the use of SI in projects and criteria documents. NAVFAC policy is to use the metric system of measurement (International System of Units, SI) in planning and design criteria, Unified Facilities Guide Specifications (UFGS), and construction contract documents for MCON/MILCON, BRACON, and family housing, regardless of contracting method. See exception under paragraph 2-2.2 General Policy.

2-2.1 SI Definitions.

Hard Metric measurement: The actual size, capacity, or other measurement characteristic of a product is changed to a rational metric value. This measurement is used in the manufacturing process.

Soft Metric measurement: A simple arithmetical change from inch/pound to SI units, using a conversion factor, so that actual measurable characteristics remain virtually unchanged, or at least within the former tolerance limits.

Example: 4 foot by 8 foot panel is hard converted to 1200 mm by 2400 mm, or soft converted to 1219.2 by 2438.4 mm.¹

2-2.2 General Policy.

In accordance with Public Law 94-168, design and construction of new or renovated facilities must use the metric system of measurement, unless its use is impractical or is likely to cause significant inefficiencies or loss of markets to United States firms.

Specify hard metric products unless such products are unavailable or uneconomical. Do not use dual units on drawings on any type of project. The design agent project manager is responsible for making the determination on whether or not to use the metric system of measurement on a project-by-project basis. Decisions to not use the metric system must be justifiable and documented in permanent project files. Comply

¹ Definitions and example extracted from Fishman, Bernard L./Loshak, Lionel/Strelka, Charles S. Metric Architectural Drawing. Canada: John Wiley and Sons, Inc., 1981, p. 11.

with Facilities Engineering Systems Command (FEC) process for determination of exception for the metric system.

2-3 OWNERSHIP OF PROJECT DOCUMENTS AND DATA.

The clauses set forth in DFARS 252.227-7023, DFARS 227.71, and DFARS 227.72 apply to project documents and data.

2-4 OPERATION SECURITY (OPSEC).

The OPSEC process provides a means of screening information prior to public release in order to prevent aggregation with other information, ultimately revealing DoD intentions or capabilities. Publicly released documents such as field investigations, reports, studies, Basis of Design, calculations, drawings, specifications, or DB Request for Proposals (RFP) must not reveal sensitive or critical information.

2-4.1 OPSEC Review.

Include an OPSEC review by the requesting activity as part of the normal review process; prior to public release to identify information that may require protection. Where applicable, modify details and identifying information in order to eliminate information the requiring activity has identified as sensitive or critical. When CUI cannot be redacted from documents, mark and handle documented in accordance with DoDI 5200.48.

2-4.2 Mission Information.

DoD installations support units and missions that may be considered sensitive, critical or even classified. In addition, every DoD command performs a core, unclassified mission. Although unclassified, individual tasks required for a command to accomplish its mission may contain information that when pieced together with other information, reveal sensitive, critical, or even classified information.

2-4.3 Information Compilation.

The compilation of information that is individually unclassified may be classified as a result of the compilation. Classification requires a classification decision by an Original Classification Authority (OCA). NAVFAC is not an OCA.

2-4.4 Sensitive or Critical Information.

Sensitive or critical information is unclassified or controlled unclassified information (CUI) concerning the DoD activities, intentions, capabilities, limitations, or vulnerabilities. 11 SECNAVINST 3070.2A /1/ contains a critical information list. In addition, the following is provided to help avoid the disclosure of sensitive or critical information that must not be included in publicly releasable materials.

- Do not identify a command if their mission or portion of their mission is considered critical or classified.
- Do not identify a command's mission or the mission supported by a facility if the mission is considered critical or classified.
- Do not identify the capabilities or vulnerabilities of physical security or antiterrorism protective measures.
- Do not identify the location of a Sensitive Compartmented Information Facility (SCIF).
- Do not identify location of a Special Access Program Facility (SAPF).
- Do not identify Defense Critical Infrastructure.
- Do not identify the location of Communications Security (COMSEC) Equipment.
- Do not identify Take Charge and Move Out (TACAMO) systems or mission.
- Do not identify Nuclear Command, Control and Communications (NC3) systems or mission.
- Do not identify Military Strategic and Tactical Relay (MILSTAR) systems or mission.
- Do not identify Advanced Extremely High Frequency (AEHF) systems or mission.
- Do not identify purpose or frequency range of antennas or communication systems.
- Do not identify Low Frequency (LF) or Very Low Frequency (VLF) transmission systems, missions, or specific location or site of the LF or VLF system.

Sensitive area locations such as SCIF and SAPF, may be labeled as "Controlled Area" and may be shown on public releasable documents with the approval from the requesting activity's Site Security Manager or Officer.

2-5 REGISTRATION.

Develop stateside project documents under the direction of a Registered Architect or a Professional Engineer currently licensed in accordance with FAR 52.236-25. Develop foreign project documents under the direction of a Registered Architect or a Professional Engineer currently licensed by a United States state, commonwealth, or territory, the District of Columbia, or as permitted otherwise by the contract.

Each drawing must only be signed, sealed, and dated by the Registered Architect or the Professional Engineer who is registered to practice in the particular field involved for work depicted on that drawing, serves as the Designer of Record (DOR) for that work,

and complies with requirements of FAR 52.236-25. Sign Record Documents in accordance with Chapter 12.

2-5.1 Certification.

Where special certifications are required for the design, certify in accordance with the contract and local requirements.

2-6 PROHIBITION OF POSTING CONTROLLED UNCLASSIFIED INFORMATION DESIGN DELIVERABLES ON UNSECURED SERVERS.

Design deliverables may contain Controlled Unclassified Information (CUI) or Department of Defense Unclassified Controlled Nuclear Information (DoD UCNI). The release of this information into the public domain may compromise an installation or facility's Antiterrorism (AT) or physical security protective measures. Examples include the design analysis where the design basis threat (DBT) is an explosive weight and the location of a SCIF or SAPF. Protect deliverables, such as drawings, specifications, calculations, cost estimates, and other design related information, that contain CUI, in accordance with DODI 5200.48.

2-7 DESIGN DELIVERABLES FOR NAVAL CONSTRUCTION FORCES - MARINE LOGISTICS GROUPS AND NAVY CONSTRUCTION BATTALIONS (SEABEES).

Due to the nature of the work performed by the Marine Logistics Groups and the Seabees, the design deliverables for their use must be tailored for expedient construction. Deployed battalions may be in remote locations under austere conditions. Researching materials and transmitting submittals can be difficult, if not impossible. Specify materials and performance requirements on the drawings to the most practical extent. Specify materials available on the Federal schedule supply lists, the battalion's supply schedules, or by product name (Contracting to include brand name or equal FAR clause in the solicitation). Avoid referencing codes or standards where possible, as reference materials may be difficult for the Battalion to obtain in the field.

2-8 OVERSEAS LOCATIONS TRANSLATIONS.

Prepare construction drawings in dual language at a majority of the overseas locations. Unless the contract scope indicates otherwise, translation of specifications is not required. Where dual language is required, the Host Nation A&E must accurately translate required documents such that they are clear and comprehensible to the local construction community. The Host Nation A&E may also be contracted to translate Government furnished studies, surveys, geotechnical reports, product specifications, host country requirements or other technical documents prepared in a foreign language and serve as an interpreter when meeting with local officials and contractors. Include translations with the Pre-Final (100%) submittal, and through project completion.

CHAPTER 3 ROLES AND RESPONSIBILITIES

3-1 DESIGNER OF RECORD (DOR).

3-1.1 Coordination with Command, Major Claimant, Region, and Activity.

Engage in and provide liaison with the Activity, and appropriate Activity personnel, in accordance with the contract, and during early design-development or RFP development.

The DOR is responsible for architectural and engineering aspects of the project to ensure reasonable facility cost appropriate for the functions performed through design and RFP development.

3-1.2 Coordination with Other Government Organizations.

Coordinate design input and reviews with other Government organizations described in this chapter in paragraph 3-2 Other Government Organizations and in accordance with the contract.

3-1.3 Document Review and Checking System.

The Document Review and Checking System (DrChecks) facilitates the formal review of complex project documents. DrChecks automatically tracks, collates, and measures technical discussions. Project documents can be uploaded into the project folders for download and review. Provide design reviews in DrChecks in accordance with the Contract. Contact the Government Design Manager to obtain registration information. DrChecks can be accessed at ProjNet.org (<https://www.projnet.org>).

3-1.4 Response to Review Comments.

Respond to comments in DrChecks or in accordance with Contract requirements. The DOR or Contractor is responsible for the resolution and incorporation of government comments into the project design. At each submittal, return and address previous review comments. Provide responses to review comments that clearly indicate what action is being taken to resolve the comment. If the comment was incorporated into the design, a response must so indicate; otherwise, provide acceptable technical justification for comments not being incorporated. Prior to the next submittal, contact the Government reviewer to discuss and resolve each comment that will not be incorporated.

The DOR is responsible for using professional judgment and technically evaluating user comments that suggest technical changes to design.

3-1.5 Final Approval.

The DOR reviews and gives final approval for contract project documents prepared under their direction. The DOR must be registered in the discipline for the documents they approve as described in Chapter 2, paragraph 2-5 Registration.

3-2 OTHER GOVERNMENT ORGANIZATIONS.

3-2.1 Commander, 1st Naval Construction Division.

Projects scheduled for accomplishment by Naval Construction Forces are reviewed at an early Design Development stage by Commander, 1st Naval Construction Division, for construction methods and procedures.

3-2.2 Reviews for Health Hazards During Facilities Design Process.

For facilities projects that require industrial hygiene technical assistance and that involve potential health hazards such as toxic materials, non-ionizing radiation, noise, or other health hazards, consult the appropriate Naval Environmental Health Center (NEHC) for the activity. The NEHC activity is required to participate in design and RFP development reviews and reviews of plans, specifications, or RFP for these projects. The NEHC activity will ensure that engineering designs properly consider and provide for adequate environmental controls for the elimination of health hazards. Also use this review process for medical facility designs in excess of \$1 million.

3-2.3 Naval Information Warfare Center (NIWC).

NIWC provides reviews and design input for projects where NIWC is providing and installing equipment as identified in the DD Form 1391. The drawings of cable and equipment layout are often provided by NIWC to the DOR, for incorporation into the design. Coordinate closely with Government Project Manager and their NIWC representative to receive timely input and to reduce impact to design and construction schedules and project costs.

Projects, even if prepared by NIWC, must bear the standard NAVFAC title blocks and drawing numbers. On drawings that require NIWC approval, NIWC signature can be applied in the NAVFAC Signature Block in the supplemental location and the NIWC drawing cross reference number can be provided on the border sheet. NIWC may also need to review where project impacts an adjacent facility, such as electro-magnetic radiation from police stations or hospitals affecting antennae, transmitters, and receivers.

3-2.4 Civil Works.

NAVFAC approves drawings and specifications prepared for civil works subcontracts. Assign NAVFAC drawing numbers to civil works contract drawings and approve and sign the drawings as "Satisfactory to" the prime contractor of the particular Navy industrial plant for whose use the facility is provided.

3-2.5 Historic Preservation Compliance.

Section 106 of the National Historic Preservation Act requires Federal agencies to take into account the effects of their undertakings on historic properties that are eligible for listing in the National Register of Historic Places (NRHP). Historic properties may include archaeological sites, individual buildings, historic districts, landscapes, structures, objects, and traditional cultural properties. In accordance with established procedures at each installation, an action proponent files a National Environmental Policy Act (NEPA) Compliance Checklist plus a copy of the Work Request or Project Description with the Installation Cultural Resource Manager (CRM). The CRM then reviews the Project Description and determines whether the project has the potential to affect historic properties or whether it is exempt from Section 106 compliance. The CRM will then either record that the undertaking is exempt or engage in consultation for Section 106 Compliance in accordance with 36 CFR 800.

3-2.6 Overseas Cultural Resources.

At Installations outside of the United States, coordinate with the applicable host nation regarding possible adverse effects to cultural resources.

3-2.7 NAVFAC Medical Facilities Design Office (MFDO).

Special coordination is required for coordination of medical facilities. Coordinate in accordance with UFC 4-510-01.

3-2.8 Sensitive Compartmented Information Facilities (SCIF) and Special Access Program Facilities (SAPF).

Special coordination is required for projects associated with a SCIF or SAPF. A designated Government Site Security Manager (SSM) is assigned to the project. The SSM is responsible for the project's security requirements and will prepare a Construction Security Plan (CSP), Fixed Facility Checklist (FFC) and the TEMPEST addendum to the FFC (referred to as the TEMPEST Form A) for the project. The SSM will submit these documents to the Accrediting Official (AO) for approval. The DOR assigned to the project must assist the SSM in documenting the facility and site requirements necessary for the preparation of these documents. The AO-approved CSP, FFC and TEMPEST Countermeasure Review contains project requirements that must be incorporated into the project, in order for the facility to be accredited. Refer to UFC 4-010-05 for additional information.

3-3 COMMANDER, NAVFAC.

Authority and responsibility for formal approval of drawings and specifications and RFPs by, or for, the Commander, NAVFAC, is vested in the Facility Engineering Systems Command, Chief Engineer, Design Director (PDC4), and PMEB Design Director.

The level of approval and responsibility for DB drawings and documents, submitted by the Contractor and signed by the Government, are defined in the RFP contract.

This Page Intentionally Left Blank

CHAPTER 4 DELIVERABLE: FIELD INVESTIGATION

4-1 PURPOSE AND SCOPE.

The site approval process includes field investigation and verification. This early effort provides more defined project scope and cost and can rule out a site. Many of the functions identified under this heading are also essential during the DD Form 1391 validation process to assure the project has the appropriate funding based on the scope of work. This section is not applicable for post-award design services of DB contracts unless specifically addressed in the RFP.

4-2 RESPONSIBILITIES.

The Government installation planners are responsible for obtaining information required for project site approval prior to design. The DOR must obtain site and building data and investigate existing site conditions, utilities, and facilities to properly integrate the design of the project with existing conditions. Except as otherwise contracted, field investigations must include complete and accurate site investigation, topographic survey, and verification of location, ownership, and availability of utility and drainage systems. When available, research existing record drawings for information. Field verify record drawings information and other site features that may influence project design.

In a DB contract, the DOR is responsible to verify site information furnished in the Government issued RFP. In addition, the DOR must provide additional field investigations and verification of existing site conditions as may be required to support the development of the design and construction of the project.

4-3 COORDINATION.

Coordinate site work, including topographic and soil surveys, with representatives of the Public Works, Utilities and Energy team, Utility System Owners on privatized Installations, and other NAVFAC design personnel. Obtain technical review by Installation utilities engineers to ensure alignment and compatibility with existing and proposed utilities systems as part of the QA/QC review process. For utilities projects, ensure requirements are obtained from the Installation utilities engineers and that they are included in charrettes and reviews. During execution of field investigation work, the DOR is responsible for obtaining necessary permits, and complying with applicable laws, codes, and regulations, including OSHA regulations. The exact location of the geotechnical excavation, whether by drilling or digging, must be approved by the appropriate authorities, be it the local utility service or by a company hired by the geotechnical engineering firm to "scope" utilities. The DOR is responsible for damages to persons and property that occur as a result of their fault or negligence. The DOR must take proper safety precautions to protect the public, the property of the public and the Government from physical hazards and unsafe conditions. Upon completion of field investigation, return the property to its original condition except as released in writing by the client activity.

4-4 TOPOGRAPHIC SURVEY.

Provide a topographic survey of the project site in accordance with the National Society of Professional Surveyors (NSPS) *Model Standards for Topographic Surveys* with the following modifications:

- Project drawings by the Government must be in English or Metric as directed for each specific project.
- Ensure that adequate adjacent areas are included within the survey limits to clearly indicate and accommodate standoffs required by antiterrorism criteria, offsite drainage and offsite utility connections impacting the project.
- Provide a boundary survey and location of easements, standoffs, and security clear zones within the limits of the scope of work.
- Show horizontal control used during field survey. Indicate the reference coordinate plane and provide two permanent control points for reference. Include description of points (such as PK nail in cap). Provide a minimum of three reference distances to existing permanent structures (reference points) so that control can be re-established.
- Show elevations on paved or impervious surfaces (including rims of utility structures) to the nearest 0.01 feet (0.005 meters for metric designs). Show elevations on unpaved or pervious surfaces to the nearest 0.1 feet (0.05 meters for metric designs).
- Indicate the name of the surveying firm and date of survey.
- If match lines are used involving more than three sheets, provide a key map with current sheet highlighted. Remove extraneous lines and text from key map.
- Orient North toward the top (or left edge) of the plotted sheet. Coordinate north direction with other disciplines so that plans are oriented the same.
- Accurately locate (by means of structures visible from the surface and through research of Activity utility maps, record drawings, data from local utility companies) the following list of utilities (both above and below ground), structures and features. Provide notes indicating the sources, limitations, or assumptions of the data, and that the Contractor must field verify the location of utilities prior to construction. Include in the survey the following specific items and their related appurtenant above-ground features, but is not limited to:
 - Buildings: Describe building material and number of stories.
 - Pavements: Include type of material. In areas where pavement demolition is to occur, note each pavement thickness, including layer thicknesses and joint patterns for replacement. Pavement layer thicknesses may be obtained by reviewing record drawing information,

digging at the edge of the pavement, core drilling, and consulting with Activity personnel. Where proposed pavements are expected to abut existing pavements, provide pavement markings, joint pattern, and indicate joint types of the existing pavements.

- Surface Drainage Features: Indicate normal water level for permanent standing water.
- Utilities: Include rim elevations for utility structures; location and identification of lines as underground or aboveground; pipe sizes and materials. Identify water system as potable, non-potable, high pressure or saltwater as applicable. \1\ Ensure communication lines are identified. /1/
- Fences: Note height, type of fabric, barbed wire, direction of outrigger, top or bottom rails, tension wires, gate locations and types.
- Foundations: Indicate visible foundations of demolished buildings.
- Fuel Pipes and Storage Tanks: Include information such as fill ports, vent lines, and tank drains.
- Pump Stations: Include invert of influent pipe and elevation of force main. Locate above ground elements including controls.
- Railroads and Crane Rails: Include turnouts, rail sizes, compromise joint locations, and curve information, such as P.C., P.T., and P.I. as they may be applicable to the design requirements of the proposed project.
- Tidal Shoreline: Note water elevation, time of day, date, and tidal condition at time of survey. Indicate normal high/low water elevations referenced to the datum used.
- Trees/Woods: In wooded areas, locate outside drip line of wooded area, include general density and type of trees. Where selective clearing will be accomplished, locate individual trees and tree size over a 6-inch (152.4 mm) diameter.
- Wetland Areas: Wetland and marsh areas must be flagged and numbered by the Government prior to the survey. Locate flags and label in the same manner as marked in the field. If unanticipated wetlands are found during the survey, advise the Government's Civil Reviewer to establish additional survey requirements.

4-5 GEOTECHNICAL INVESTIGATIONS AND REPORT.

4-5.1 Existing Information.

Each Facility Engineering Command maintains record files pertaining to the geotechnical aspects of previously constructed projects. Architecture and engineering firms preparing, planning, or designing documents are encouraged to use this resource

to research existing conditions or past design approaches for facilities, structures, or pavements. Viewing or discussion of the files' contents is possible by contacting the Government. For DB contracts, relevant geotechnical or pavement information that is available will be furnished in the DB RFP for solicitation.

4-5.2 Foundation and Soils Investigation.

Perform foundation and soils investigations, including sampling, testing, and evaluation, with requirements and guidance set forth in the IBC, UFC 3-220-01, UFC 3-250-01, and UFC 3-260-02. In using the IBC, the terms "owner," "applicant," and "building official" are synonymous with the "Government." In addition, the following requirements apply:

4-5.2.1 General.

Investigations and evaluations (including soil borings, test pits, ground penetrating radar surveys, seismic refraction surveys, and electrical resistivity testing, laboratory testing) must be in accordance with ASTM standards to the fullest practical extent. The classification and investigation of the soil must be supervised by a registered professional engineer. Where ASTM methods are not applicable, procedures and apparatus used must be in accordance with generally accepted engineering practice.

4-5.2.2 Qualifications of the Testing Firm.

The qualifications of the geotechnical testing laboratory and personnel must meet ASTM D3740.

4-5.2.3 Use of Global Positioning System with Soil Investigation.

Global Positioning System (GPS) coordinates, with an accuracy of at least 3 feet (1 meter), must be taken at each soil boring, coring, or test pit location and stated on the boring/coring/test pit logs. The coordinates must reference WGS84 and be stated in degrees of latitude and longitude. Data Interchange for Geotechnical and Geoenvironmental Specialists (DIGGS) data files must be geo-located to the same standard.

4-5.2.4 Field Testing.

Field testing for geotechnical investigation typically consists of soil borings and standard penetration tests (SPT) or cone penetration tests (CPT). Conduct and provide the soil borings, SPT, and CPT in accordance with ASTM D1452, ASTM D1586, and ASTM D5778, respectively. For standard penetration testing, modify the ASTM D1586 procedure to make continuous standard penetration and sampling tests for the initial 12 feet (3.74 meters) of the boring. If the proposed building will have a basement level, the ASTM D1586 procedure must be modified to make continuous standard penetration and sampling tests for the initial 12 feet (3.74 meters) of the boring below the proposed basement floor elevation. During drilling, visually classify each soil type in accordance with ASTM D2488. If soft cohesive materials are discovered within 20 feet (6 meters) below the ground surface, or within the anticipated depth of loading influence, take

undisturbed samples for laboratory testing. Undisturbed sampling and testing must be performed at the discretion of the Geotechnical Engineer responsible for performing the investigation. Perform other testing, such as percolation testing, seismic refraction surveys, and soil resistivity testing, in accordance with the contract, or by the Contractor's Geotechnical Engineer or DOR in a DB contract.

4-5.2.5 Use of Piezometers.

If drilling techniques are used that prevent the measurement of the water table levels, provide at least two piezometers per drilling site to measure the depth more accurately to the water table. Piezometers are required for storm water pond investigations. Piezometers are not required if the ground water levels can be accurately measured during drilling operations or there is good evidence that the water table is not within the depth of the borings or zone of influence for the foundation or structure.

4-5.2.6 Seismic Site Class Determination.

Base seismic site class on field testing for projects.

For DB projects, state in the RFP the seismic site class to be used for design. This can be determined by the cognizant NAVFAC Geotechnical engineer. NAVFAC is the ultimate authority on site class determination for design.

4-5.2.7 Laboratory.

The minimum laboratory testing must include grouping like samples, conducting a sieve analysis and Atterberg Limits tests, and performing natural moisture content determinations to effectively depict in-situ conditions. Update the field logs in accordance with ASTM D2487. Perform other testing, such as California Bearing Ratio, unconfined compressive strength, consolidation testing, triaxial testing, and potential volume change in suspected expansive clay areas, in accordance with the contract, or by the Contractor's Geotechnical Engineer or DOR in a DB contract.

4-5.3 Geotechnical Report.

Provide a geotechnical report on contracts unless waived by the Government's Contract Technical Representative or as stated otherwise in the contract. Describe in the report the regional geology, topography, and other physiographic information that may influence the geotechnical design. Describe and discuss the investigation program, exploration and testing techniques/procedures used to characterize the site. Depict in the report the soil stratigraphy, materials, and groundwater conditions at the site. Specifically address in the report the groundwater levels expected to be encountered in construction under normal conditions, and site-specific factors (such as tidal action, climate, seasonal flooding, or droughts) that may influence the groundwater levels. Include copies of pertinent U.S. Geological Survey Maps used. Geotechnical Reports must be signed by a registered Professional Engineer. Provide a digital copy of the report in Adobe Acrobat (PDF) format to the Design Manager and the government civil or geotechnical project engineer via DoD SAFE (<https://safe.apps.mil/>). Produce the

PDF copy of the report directly from the report's authoring software. Each heading, subheading and appendix in the PDF version of the report must be bookmarked. Format the document so that the bookmark panel opens when the report file is opened. Reports not meeting these requirements will not be accepted. Upload geotechnical data in a DIGGS compatible format.

4-5.4 Boring Logs.

Provide a scaled location plan, boring logs, ground water observations, laboratory data, and boring log legend and description notes on NAVFAC drawings as indicated in Chapter 12. Summarize the laboratory data in tables. No scanned boring logs will be accepted.

4-5.5 Foundation and Site Preparation.

Discuss the facility under design and make recommendations for the foundation type. Describe and specify the improvements that are required for shallow foundations, such as compaction, removal and replacement, surcharging, and wick drains. Describe the soil bearing capacity, anticipated settlements, seismic aspects, pile capacity, pile length, pile type and special instructions such as jetting, pre-drilling, and testing required. Discuss earthwork associated with foundation design and construction or site improvements, including settlement, liquefiable soils, expansive soils, slope instabilities or near surface groundwater. The discussion must address existing conditions, studies, or analysis performed, and recommendations for mitigation of the effects of these conditions. Address dewatering, and sheeting/shoring considerations, in design and construction, as applicable. If required by the DOR, state the pavement design parameters and the pavement design. If the pavement design is to be completed by others, provide design parameters determined from the subsurface investigation. If multiple structures are being designed, address structures on an individual basis. Discuss the site preparation and susceptibility to rain and construction equipment. Discuss soil conditions relating to potential concrete or piping corrosion and recommendations to mitigate effects thereof.

4-5.6 Airfield Pavement Evaluations.

Provide Airfield Pavement Evaluations in accordance with UFC 3-260-03.

4-6 FIRE PROTECTION INVESTIGATIONS AND SURVEY.

4-6.1 Utilities and Infrastructure.

4-6.1.1 Water Flow Testing.

4-6.1.1.1 Existing Water Supply.

Water flow testing of the existing water supply system(s) is required to determine the capability of the available water supply to support the expected fire flows and fire suppression system demands. Perform testing in accordance with NFPA 291. Provide

a fire protection water flow test report in the Basis of Design. Comply with UFC 3-600-01. While historical flow data may be a valuable resource when performing an analysis of the existing water supply system, historical data must not be the sole source of data. A water flow testing must be performed by the Qualified Fire Protection Engineer (QFPE) during the field investigation.

4-6.1.1.2 Combined Sprinkler and Hose Stream Demand.

During water supply testing, flow sufficient water to meet or exceed the combined sprinkler and hose stream demand. If the Installation's existing water distribution system or dedicated fire main includes existing fire booster pumps, conduct testing with pump controller(s) configuration configured based on activity policy for normal operating conditions. If there is a requirement for a redundant pump, disable one pump for the duration of the test. If, at the time of design, the booster pumps cannot be run and accurate flow testing cannot be conducted, include the following information in the contract documents:

- Show water distribution piping back to the booster pumps. Show the location of water supplies such as elevated water storage tanks.
- Identify make, model, rated characteristics of each booster pump and the number of booster pumps expected to be operating, based on the anticipated hydraulic demand. For stations with multiple pumps, confirm that one pump was designated "redundant" when there is a requirement for redundancy.
- Identify available water supply (flow test data) at the suction side of the booster pump(s).

4-6.1.2 Hydraulic Supply Analysis.

Evaluating the available water supply is critical for buildings with and without sprinkler protection. Documents cannot be released for advertisement with expectations of the contractor determining the available water supply. The capability of the water supply to support the required fire flow demand must be confirmed prior to advertisement. The QFPE, as defined in UFC 3-600-01, is responsible for obtaining water distribution maps, establishing flow testing procedures and coordinating flow testing with the base fire department and public works. If the station does not allow contractors to conduct the flow tests, the station personnel can perform the flow test under the direct supervision of the QFPE. The QFPE must not, under any circumstance, rely on data from flow tests which they did not personally supervise. The QFPE is responsible for conducting the actual flow testing for facilities that are not on federal property. The QFPE must graph the results for comparison with the anticipated hydraulic demand. This analysis is required for both sprinklered and non-sprinklered facilities.

4-6.1.3 Base-wide Fire Reporting and Mass Notification Systems.

Obtain information regarding the exterior fire alarm reporting system and the base mass notification systems.

4-6.2 Site and Building Surveys.

Design services must include surveys to obtain information about adjacent structures and property lines, existing building construction, and existing building systems and features.

4-6.2.1 Site Planning and Adjacent Structures.

When the proposed construction is within 60 feet (18.3-m) of existing adjacent structures, conduct a site survey to obtain information regarding the adjacent structures. Information about adjacent structures must include construction type, fire resistive rating of exterior walls, number of floors, area per floor, total building area, occupancy classification, and if the building is fully protected with an automatic fire sprinkler system.

4-6.2.2 Work in Existing Facilities.

Projects involving repairs, renovations, or modifications to existing facilities must include a survey, to establish the existing conditions regarding compliance with current life safety code and building code requirements, based on the intended use of the building facility. Survey must also include a description of the active fire protection systems (fire alarm and fire control/suppression). Determine the make, model, type, and year of the building fire alarm system. Projects modifying existing fire protection systems must include a thorough investigation of existing systems and site conditions to determine capabilities of the existing utilities to support the modifications/expansions of the effected fire protection systems. The existing systems being modified must also be thoroughly investigated to determine that compatible products, devices, and components are available.

4-6.2.3 Building Additions.

Building additions must include a building code and a life safety code survey to establish the existing conditions and, based on the intended use of the building, the level of compliance with the current editions of the IBC and Life Safety Code. Conduct an existing building survey to obtain construction type, fire resistive rating of exterior walls, number of floors, wall openings, area per floor, total building area, occupancy classification, types of fire protection systems and extent of protection. Building code assessment must establish the maximum allowable size (height and area) based on the existing building features and the proposed building expansion. Determine the make, model, type, and year of the building fire alarm system. Determine expansion capabilities of the existing fire alarm system, power supply and circuits to support the additional devices, appliances, and functions. Validate that new devices are available and compatible with the existing fire alarm system. Provide a Life Safety Code

assessment of the existing building. Perform Building Code and Life Safety Code surveys must be in accordance with UFC 3-600-01.

4-7 ENVIRONMENTAL REQUIREMENTS.

Conduct surveys, information gathering, and analytical testing required by the contract. Provide in accordance with UFC 3-810-01N, which is a requirement, as invoked by this FC.

This Page Intentionally Left Blank

CHAPTER 5 DELIVERABLE: BASIS OF DESIGN

5-1 GENERAL REQUIREMENTS.

The Basis of Design is a narrative presentation of facts, sufficiently complete, to demonstrate that the project concept is fully understood, and that subsequent design details, and their ultimate presentation in the final drawings and specifications, will be based on sound architectural and engineering decisions. For DB RFP Development, the Basis of Design requirements are provided in PART 3 - Project Program and throughout the document.

Submit the Basis of Design required at each design stage in accordance with the contract, the Core UFC's, and the additional Discipline requirements herein. If another UFC adequately describes the requirement for a Discipline's deliverable, a paragraph for that Discipline is not provided below. For each Discipline in the Core UFC and contract, provide a discussion and description of the design and describe the functional requirements of the project and the expectations of how it will be used and operated, including, but not limited to: system goals, measurable performance criteria, cost considerations, applicable benchmarks, additional success criteria required by the project, and supporting UFCs, Codes, and Standards referenced.

5-2 FORMAT.

Format the Basis of Design as an 8 1/2 x 11-inch (216 x 279 mm) document, organized by Discipline. \1\ Bookmark Basis of Design as a PDF for the electronic submittals. Bookmark each discipline and chapter along with each appendix. /1/ Provide a cover sheet identifying the document as the Basis of Design, and include the following:

- Submittal stage
- The project title
- The location
- A-E Contract or Construction Contract number (Post-Award DB Contracts only)
- Contract Task Order Number (if Indefinite Quantity contract)
- Contract Type (DB or DBB)
- The eProjects Work Order Number
- The Firm's name
- The Command, or the Contractor name; and
- The date

Only use the Maximo number, in lieu of the eProjects Work Order Number, if eProjects is not required for the project.

5-3 KEY PROJECT CONTACTS.

Identify the Key Project Contacts including Role, Organization, Name, Email, and Phone. Sample tables for inclusion in the Basis of Design are located in Appendix C.

5-4 BIM PROJECT EXECUTION PLAN (PXP).

For projects that require, or opt to utilize, BIM, provide a comprehensive Chapter in the Basis of Design that summarizes:

- Project Goals, BIM Objectives, and Unique BIM Requirements (3D Parametric Design Model, Record Model, DOR Edited Model, and Facility Data Matrix tab from eOMSI Facility Data Workbook)
- Organizational Roles and Staffing for each BIM use (Design Facility Data, Design Modeling, and Clash Detection are required by NAVFAC)
- Strategy for Quality Control of the model including Review Frequency and Software Utilized (Visual Review and Clash Detection are required)
- Technological Infrastructure Needs for each BIM use (Include Software and Version)
- Model Organization (Model Structure and Measurement System)
- BIM Project Deliverables by Design Phase (Include the format in which the information will be delivered)

Sample tables for use in the BIM Chapter are located in Appendix C.

5-5 SUSTAINABILITY.

Provide a comprehensive Sustainability Chapter in the Basis of Design that summarizes how the design will achieve the requirements of UFC 1-200-02 and Third-Party Certification (TPC) (where applicable). Address each discipline in the summary, elaborate on the various requirements, and where full compliance is not possible, include proper justification. Provide the following:

- Sustainability chapter
- The NAVFAC High Performance Sustainable Building (HPSB) Checklist for each applicable building in the project
- TPC Checklist (where applicable) for each applicable building in the project, and
- Justification for each missed or partially met requirement (where applicable)

No variations or substitutions to the Checklist(s) are allowed without Government approval.

5-5.1 Guiding Principles Validation.

The DOR is responsible to verify Guiding Principles Validation, in accordance with UFC 1-200-02 requirements, by including design requirements in the contract documents and verifying construction submittals when required by the contract.

5-5.2 Pre-award Commissioning Services.

When the project requires pre-award Commissioning services, incorporate comments, reports, (Owner Project Requirements (OPR) where required by third-party certification program), and other documentation related to commissioning effort, in accordance with UFC 1-200-02.

5-6 ANTITERRORISM (AT).

Provide an Antiterrorism (AT) section in the Basis of Design that summarizes how the design complies with the DoD minimum AT standards in UFC 4-010-01 and the applicable Geographic Combatant Commander's AT Construction Standards. As a minimum, include the following in the summary:

- Facility description including occupancy (low occupancy or inhabited)
- Narratives of how each applicable standard is met
- Site plan dimensioning standoff distances
- Protective measures above the minimum
- Identify applicable Geographic Combatant Commander's AT Construction Standards
- Level of Protection

Note: Do not identify explosive weights to avoid disclosure of CUI information.

5-7 GEOTECHNICAL.

Include in the Basis of Design (BOD) a paragraph briefly describing the geotechnical investigation program, the recommendations for the site preparation, and the recommendations for the building foundation and pavement design.

It is preferred that the geotechnical report be included in the BOD as an appendix. However, the schedule may preclude the completion of the field investigation prior to the submittal of the BOD. If this is the case, describe the assumed basis of design for the foundations and pavement, and submit the geotechnical report as soon as possible, and as acceptable to the Government.

5-8 CIVIL.

Identify the governing codes and criteria including federal and military handbooks being used for the design. References may be noted in the related sections listed below. Include reference titles and date of publications. Provide BOD with adequate narrative to describe design logic and assumptions. Show adherence to scope of work.

5-8.1 Existing Conditions.

Include the following:

- a. Describe general site topography and vegetation type (grass, lightly wooded, brush). Describe existing site features.
- b. Identify whether existing underground features, such as footings, foundations, or steam pits, exist, and describe.
- c. Describe existing soil conditions.
- d. Describe existing utilities, including size, type, and general location. Discuss impact that this, and future projects, will have on utility systems.
- e. Identify predominant drainage features, including required downstream improvements. State whether field survey has been coordinated with delineation. Indicate the parties that have been notified of the presence of wetlands and are actively involved in this issue.
- f. Identify and describe if endangered species inhabit area.
- g. Identify and describe existing traffic patterns on and around site.
- h. Provide horizontal and vertical datum and other pertinent survey information.

5-8.2 Demolition.

Discuss demolition relating to Civil issues only, typically 5 feet (1.5 m) outside of building line. Identify buildings slated to be demolished by building number. Generally, describe structure types (examples: 1-story frame, 2-story block); include building specifics under the Architectural BOD. Describe pavement to be demolished, including existing pavement section. Describe underground and overhead utility demolition, relocation, and abandonment. Describe other features to be removed (examples: play equipment or fencing).

5-8.3 Site Work.

Describe building and its function with respect to civil issues, such as vehicle ingress/egress and pedestrian movement. Address internal functions under Architectural BOD. Describe pedestrian access. Identify number of parking spaces; include stall and aisle widths. Describe handicap access in and around site, number,

and size of handicap parking spaces. Identify physical security requirements, such as intrusion detection provisions, fencing type and height, and lighting requirements. Also identify antiterrorism standoff distance requirements for the specific site conditions. Identify vehicle type expected on project site; note non-standard vehicle sizes and weights. Identify design wheel loading. Define projected traffic volume. Define pavement types and sections. For airfield pavement, discuss design parameters, including pavement use, loadings, design life adopted in design, design methodology to be used, and availability of materials anticipated for construction, and possible impacts construction may have on airfield operations, such as haul routes and closures. For railroads and crane rail, state type of service for which rail track will be provided; anticipated volume and type of traffic; and the ruling grade and the maximum curvature. Describe proposed type, source and thickness of ballast, weight of rail and source, treatment, and dimensions of ties. For small arms ranges, list expected weapons and ammunition including the most powerful weapons/ammunition combination that the design is based on. Discuss critical features such as impact berms (including height and slope), side berms, firing lines, firing directions, target locations, bravo flag poles, road gates, fencing, access roads, supporting facilities, and other prominent feature. Do not include the Surface Danger Zone since this has nothing to do with the construction project.

5-8.4 Water Supply.

State design parameters such as domestic flow, fire flow, residual pressure, and recent flow test data. State anticipated demand. Coordinate with the QFPE to establish fire flow requirements. Describe water main and supply line sizes, capacities, and water velocities. Identify connection points. Identify connection methods. Identify whether existing infrastructure has capacity to support project. Identify requirements for backflow protection and freeze protection. Identify needs for metering. Identify need for booster pumps or pressure reducing valves. State the number of new fire hydrants. Provide number of wells and proposed pump rates.

5-8.5 Sanitary Sewer.

Describe waste stream and whether it is from domestic or industrial source. Include sources of hazardous substances. Identify design population, peak and average flows. State whether sewer will be gravity or force main. Identify pre-treatment requirements and solutions. State minimum pipe slopes and velocities. Identify special installation requirements. State new pipe sizes and capacities. Identify pump station type, wet/dry well, types of pumps, pump capacity and total dynamic head, horsepower, telemetry requirements and compatibility with existing on-base systems, backup power requirements, and assumed response time by Activity personnel. Consult Activity as to whether existing system is operating at or near capacity. Discuss adequacy of existing system to handle current and future flows.

5-8.6 Wastewater Treatment.

Identify completed treatability studies. Briefly describe recommended process noting deviations from the treatability study. Define impact of stream condensation and cooling water discharges on sewer piping and treatment plants and the estimated cost of distribution and treatment of this additional loading.

5-8.7 Storm Drainage System.

Identify factors such as receiving waters, classification (if applicable), storm frequency, and C factors. Discuss adequacy of existing storm system and its effects on downstream facilities and systems. Discuss whether existing system will require upgrades. Identify use of collection system versus sheet flow. Describe materials and pipe sizes. Describe how upstream flows that impact site will be handled.

5-8.8 Stormwater Management.

Identify Integrated Management Practices (IMP's) and approach to stormwater management. Discuss compliance with UFC 3-210-10, Navy LID Policy, Activity, State, and local requirements.

5-8.9 Erosion & Sediment Control.

Identify total disturbed area acreage. Discuss erodibility of soil, devices, or methods to be used to control erosion and sediment losses, and protection devices at outfalls. Discuss compliance with Activity, State, and local requirements.

5-8.10 Permits.

Identify the permits necessary for both construction and operation of facilities. Identify fees associated with each permit. Submit Permit Record of Design (PROD) form with BOD.

5-9 STRUCTURAL.

Provide a narrative report on how the design concept satisfies the customer's requirements, meets criteria, and is cost effective. Include statements on the following:

- List a summary of the criteria upon which the structural design is based. Including a statement of each load: dead, live, wind, snow, earthquake, and other significant load.
- List assumptions required for the structural design where the design criteria is undefined, unclear, conflicting, or unknown. State the basis of the assumption made.
- Describe the structural floor and roof systems. Include a discussion of both the gravity and lateral force resisting systems. Clearly describe the gravity and lateral load paths providing pertinent information such as, capacity, size, dimensions, materials, and design strengths. Define how

foundations and slabs on grade are used to distribute lateral forces between the structure and the ground.

- Provide a narrative summary of the foundation system, including method for determination of the bearing capacity, maximum allowable bearing capacity, and lateral force capacity of the foundation, as well as other soil parameters used in the design. Provide pertinent information, such as capacity, size, dimensions, and a list of materials with design strengths.
- When appropriate, provide a statement of special considerations that affect the design (such as “superflat floors” for high stack warehouses, special corrosion resistance requirements, fire-resistive requirements, or crane or monorails). Describe applicable special inspections, testing, and observations required in accordance with IBC Chapter 17, as modified by UFC 3-301-01, and IEBC, as modified by UFC 3-301-01. The generic schedule of special inspections is maintained on the WBDG as referenced in paragraph 17-11 Statement of Special Inspections.
- When using U.S. Geological Survey seismic information, provide a map showing the Latitude and Longitude of the project site.
- Provide a narrative summary of the Serviceability limits for the structure. Include the lateral drift limit for the primary lateral load resisting system for wind or seismic, roof framing deflection limit for DL + LL and LL only, floor framing deflection limit for DL + LL and LL only, and composite floor framing deflection limit for DL + LL and LL only.

5-10 FIRE PROTECTION.

Projects requiring the services of a QFPE must include a Fire Protection Basis of Design that includes the following information. Identify both the requirement and the actual design provided.

5-10.1 Project Summary.

Provide a brief summary of the project and scope of work. General information can be obtained from the DD Form 1391. Identify the purpose and use of the facility, including the following:

5-10.1.1 Specific Hazards.

Identify hazardous areas (such as chemicals, fuels, ordnance), processes, and special hazards or features requiring special fire protection considerations, such as Radio Frequency (R-F) Shielded Rooms, Secured Rooms, Computer Rooms, commercial kitchen appliances. Provide relevant information pertaining to the hazards and how they are protected.

5-10.1.2 Summary of Fire Protection Features.

Provide a brief summary of the active and passive features of fire protection. Provide a description and identify the location of new and existing fire extinguishing systems, detection systems, fire alarm systems, or fire pumps to be provided or existing systems to remain or be modified.

5-10.1.3 Summary of Existing Conditions.

Provide a brief summary of existing conditions impacting the project, such as existing detection/suppression systems or existing building construction features.

5-10.1.4 Summary of Design Enhancements.

Specifically identify items in excess of the contract, criteria, or code requirements.

5-10.1.5 Summary of Other Design Features.

Provide a brief summary of the other features of the design relevant to the fire protection of the project. Examples of “other features” include structural engineering evaluation of existing floor systems supporting gaseous agent concentrate storage tanks.

5-10.2 Building Code Analysis.

Include the following information: occupancy classification; height and area calculations (area per floor & total); type of construction; required building separation or exposure protection; rating of structural components; classification of interior finishes; location of fire-rated walls and partitions; description of construction; whether rated floor and roof assemblies are restrained or unrestrained; interior fire or smoke rated wall/partition requirements, fire rating of each floor, ceiling system, roofing system when applicable. Discuss if and how the proximity to, and classification of, adjacent structures factors into the analysis.

5-10.3 Life Safety Code Analysis.

Base the life safety code analysis on NFPA 101, Life Safety Code. Identify occupancy classification, number of exits, type of exits, exit travel distance, total exit width, total occupant load, common path of travel, and other applicable provisions of NFPA 101.

5-10.4 Water Supply Analysis.

Provide a summary of the data obtained from the water flow test (refer to Chapter 4) and provide a determination of the adequacy of the water supply (even for facilities without sprinkler protection), along with sketches of the water distribution system. If fire flow demands cannot be met, cite the deficiencies and recommend design alternatives/solutions to correct the problem of an insufficient water supply (such as fire pump(s), or water storage tank(s)).

5-10.5 Hydraulic Demand Analysis.

5-10.5.1 Analysis.

Using computer program generated hydraulic calculations, calculate the “anticipated” demand of a facility to validate the adequacy of the available water supply, or to establish the minimum water supply required. Refer to UFC 3-600-01 for hazard classifications and design criteria determination. Proposed piping layout must accompany the hydraulic sprinkler calculations included with the Fire Protection Calculations submittals.

5-10.5.2 Plot.

Plot the available water supply versus the hydraulic demand on the Q1.85 Hydraulic Graph Paper. Present hydraulic information in graphical format as discussed in the FM Global Property Loss Prevention Data Sheet 3-0.

5-10.5.3 Adequacy of Water Supply for Fire Protection.

5-10.5.3.1 Pre-award Design Services.

If the water supply analysis determines that the water supply cannot support the anticipated hydraulic fire flow or fire sprinkler demand, contact the DFPE, as defined in UFC 3-600-01 as soon as possible. Provide appropriate supporting calculations and propose design options or alternatives for consideration.

5-10.5.3.2 Post Award Design/Construction Services.

- Design assumptions must be based on the water supply data cited in the solicitation. This data must be used as the basis for fire flow and sprinkler design even if flow testing performed by the QFPE or Sprinkler Subcontractor reveals more favorable results.
- If flow testing performed by the QFPE or Sprinkler Contractor reveals flow/pressure less than that specified, immediately submit a “Request for Information (RFI) citing the concern. Provide supporting information and calculations to substantiate the claim and request clarification or direction.

5-10.6 Active Fire Protection Features.

Provide the following information as applicable:

5-10.6.1 Description of Fire Suppression System(s).

- The area(s) that will be protected, the hazard classification of these area(s) and the type of system protecting these area(s).
- For sprinkler systems, the design density, demand area and hose stream allowance to be specified for each different area.

- The method for connecting the suppression system to the fire alarm system, as well as the method of annunciating the systems, and a description of power disconnects or pre-alarms, that are required.

5-10.6.2 Sketches.

Where appropriate, provide sketches representing the water distribution system, sprinkler demand areas, and show hydraulic reference points for the hydraulic sprinkler calculations.

5-10.6.3 Description of Fire Alarm/Mass Notification System(s).

5-10.6.3.1 Description.

- Provide information for areas of the facility and what type of initiation devices and notification appliances will be provided.
- Identify areas that may have challenging features that will make it difficult to achieve intelligibility requirements.
- Provide information for connecting to the base-wide fire reporting system and the base-wide mass notification system.
- Provide drawings or sketches.

5-10.6.3.2 Existing Conditions.

Provide detailed information on existing fire detection and suppression systems for existing buildings (examples: type of systems; area of coverage; make and model of equipment; why system is or is not being replaced). For fire alarm systems, provide the following information (at a minimum): number of spare zones and spare spaces for modules, capacity of control panel(s), list of existing fire alarm zones, list of outputs, number of audio/visual circuits, and standby battery capacity. Indicate the working order of each system (condition or status).

5-10.7 Host Nation Requirements.

Refer to UFC 3-600-01.

5-11 CYBERSECURITY.

Provide cybersecurity design in accordance with the contract and UFC 4-010-06. As a minimum, include the following:

- Facility description generally describing facility's mission.
- Confidentiality-Integrity-Availability (C-I-A) ratings for each FRCS.

- V1\ For work in existing buildings, identify and document existing FRCS infrastructure, to support project scoping and design of FRCS in project scope. /1/
- List of cybersecurity controls for each FRCS that can be satisfied within the design.
- Narrative of how each applicable cybersecurity control is met for each FRCS.

This Page Intentionally Left Blank

CHAPTER 6 DELIVERABLE: CALCULATIONS

6-1 GENERAL REQUIREMENTS.

Submit design calculations required at each design stage in accordance with the contract, the Core UFC's, and the additional Discipline requirements listed herein. If another UFC adequately describes the requirement for a Discipline's deliverable, a paragraph for that Discipline is not provided below.

Prepare calculations in metric units when metric design is required. Provide reference to the source (Navy and non-Navy criteria used) to produce the calculations.

6-2 COMPUTER GENERATED CALCULATIONS.

Provide the software program name, version and source used to produce each computer output or report.

6-3 FORMAT.

Format calculations as an 8 1/2 by 11 inch (216 by 279 mm) document. Provide a cover sheet with the title "Calculations;" the stage of the submittal; the project title and location; the A-E Contract or Construction Contract number; the eProjects Work Order Number; the Firm's name, Command, or Contractor's name; and the date. Organize calculations by Discipline, in the same order as the drawings, and in a manner appropriate for the number of sheets provided. Number each sheet. Provide an index, following the title sheet, with sub-indexes for disciplines having a very large number of sheets, and include Discipline name and page numbers. Only use the Maximo number, in lieu of the eProjects Work Order Number, if eProjects is not required for the project.

6-4 SUSTAINABILITY AND ENERGY.

Provide calculations in accordance with UFC 1-200-02 for life cycle cost analysis.

6-5 GEOTECHNICAL REQUIREMENTS.

The geotechnical calculations normally appear in the geotechnical report; however, they may be in a separate package if another consultant other than the geotechnical consultant prepares the calculations for foundations or pavement. The calculations must indicate the loadings, ultimate and allowable capacities, the safety factors, and the text or reference from which the calculations were based for the foundation and pavements. Graphs and formulae must be clearly indicated along with the derivation of curve slopes and data derived from the laboratory testing.

6-6 CIVIL.

Provide design calculations for erosion and sediment control, earthwork, stormwater drainage system, stormwater management, pavement, and utility systems.

Calculations must be legible, orderly, and easily understood and checked by a registered practicing civil engineer.

6-6.1 Low Impact Development (LID).

Comply with UFC 3-210-10. The DOR is responsible for completing and submitting the Low Impact Development (LID) Verification Report (https://www.wbdg.org/FFC/NAVGRAPH/Navy_LID_Verification_Report.pdf) and the LID Data Card (https://www.wbdg.org/FFC/NAVFAC/NAVFAC_LID_Data_Card_v3.0.pdf). The DOR must complete the design portion of the LID Verification Report and attach it to UFGS 33 40 00. Annotate the LID Verification Report as a “G” submittal, requiring Government approval.

6-6.1.1 Submittals.

The DOR is responsible for submitting the LID Data Card to the Government during pre-final and final submittals, annotating changes involving LID, and coordinating changes with the LID Verification Report. The Government’s Civil Engineer reviews the LID data submitted by the DOR and Contractor LID Verification Report, and documents this information on the eProjects LID tab. When the Government’s Civil Engineer is the DOR, design projects must be reviewed and approved by either the Civil Engineer’s supervisor or the Civil Technical Discipline Coordinator (TDC).

6-6.1.2 Navy LID Policy.

For Navy and Marine Corps projects, comply with Navy LID Policy (commonly referred to as the Penn Memo). The Navy LID policy sets a goal of no net increase in stormwater and sediment or nutrient loading from major renovation and construction projects. Major renovation projects are defined as having a stormwater component and exceeding \$5 million. Major construction projects are defined as exceeding \$750,000. Projects exceeding these dollar values must be documented on the LID Data Card and LID Verification Report as indicated in the paragraph 6-6.1 Low Impact Development. If LID is not implemented to the METF as defined in UFC 3-210-10, a waiver must be obtained from the Regional Engineer. The DOR is responsible for submitting the LID waiver request. The NAVFAC LID Waiver Form is located at: https://www.wbdg.org/FFC/NAVFAC/NAVFAC_LID_Waiver_Form_v4.doc. Coordinate the waiver and approval with the Government’s Civil TDC.

6-7 STRUCTURAL REQUIREMENTS.

Provide calculations to support items and details outlined on the drawings and specifications. Include calculations for the main framing systems and beams, columns, walls, foundations, bracing, diaphragms, equipment supports, and component inter-connections to provide a safe, stable efficient and cost-effective structural system, considering design loads and criteria. They must be legible, orderly, and easily understood and checked by a registered practicing structural engineer.

Also include the following:

- A cover sheet indicating the project title, location, construction contract number and names of the persons originating and checking the calculations.
- Table of contents.
- A brief statement describing the structural system, significant design parameters and restrictions that may affect the design.
- Applicable design criteria.
- Loads: Include loadings, forces, temperature changes, induced settlements, and other internal and external actions that may affect the design of the structure. The list must include the orientation and location, magnitude, and units of measure for each load.
- Restrictions: Include limiting factors such as horizontal and vertical deflections limits, height restrictions, installation or operating tolerances for equipment or building components and other limits to the structural system.
- Materials: Include materials used and their allowable stress limits, yield strengths, type, grade, class, or other applicable material properties.
- References: Include criteria, accepted standards, manuals, codes, texts, papers, or other references used in the analysis and design that are accepted in a public domain. Appropriately identify references; abbreviations such as AISC, ASTM, and ACI are acceptable. Document the origin of customer-specific criteria in the calculations.
- Sketches with sufficient detail and clarity to communicate design intent. Note assumptions and references to codes, standards, criteria drawings, and computer output.

6-7.1 Calculations and Test Reports for Antiterrorism.

When in project, provide calculations or test reports for the following systems demonstrating compliance with applicable Antiterrorism (AT) requirements:

- Blast resistant window systems
- Structural analysis of building elements where stand-off distances are less than the conventional stand-off distance
- Progressive collapse calculations

Note – Do not identify explosive weights as explosive weights to avoid disclosure of CUI information.

6-7.2 Design for Lateral Forces.

Design for lateral forces must include design calculations for wind, seismic, and other potential loadings. The construction drawings must depict the governing design elements base on both seismic and wind design requirements.

6-7.3 Computer Generated Calculations.

Provide input data, including loads, loading diagrams, node diagrams, and adequate documentation to illustrate the design. The schematic models used for input must show, as a minimum, nodes/joints, elements/members, materials/properties, and each loading, induced settlements/deflections, and a list of load combinations. Results must include an output listing for maximum/minimum stresses/forces and deflections for each element, and the restrictions for each loading case and combination. If required, submit narratives. In addition, provide the following:

- Submit graphical plots of structural models which must include, but not be limited to, main structural elements, boundary conditions, loading diagrams, and deflected shapes. Submit graphical plots with each deliverable at each submittal stage. Provide in both native, editable format and in PDF.
- If a modal analysis is performed, submit plots of mode shapes and a listing of the dominant natural frequencies.
- If blast or progressive collapse analysis is performed, submit comparison tables of computed rotations/residual strength ratios and response limits listed in UFC 3-340-01 and UFC 4-023-03.

If software not commonly commercially available, or widely accepted in the structural community, is used, submit validation documentation of the software (such as hand verification of the software solution of a significant, representative portion of the structure).

6-8 FIRE PROTECTION CALCULATIONS.

Provide calculations at the earliest possible stage in design, but no later than the Design Development Submittal and as further required by Chapter 15 of this FC.

6-8.1 Hydraulic Demand Analysis.

Calculate the fire flow demand for the facility. Provide calculations showing that the anticipated suppression systems and hose stream demands can be designed to the available water supply. For hydraulic calculations, deduct the hose stream requirement at the point of connection to the existing distribution systems or the closest fire hydrant; whichever is closer to the sprinkler riser and building.

6-8.1.1 New Sprinkler Systems.

Buildings requiring sprinkler systems must be hydraulically designed. Include a floor plan with the calculated piping layout.

6-8.1.2 Existing Sprinkler Systems.

Provide hydraulic calculations for additions to, or modifications of existing sprinkler systems to ensure the system demand can meet the hazard it is protecting. Establish if the existing system is hydraulically designed or a pipe schedule system. Contact the Installation Public Works Office or Installation Fire Department for information on an existing system.

6-8.1.2.1 Hydraulically Designed Systems.

Indicate the size and location of cross and feed main piping from the point of connection to the existing system back to the sprinkler riser. Indicate grid branch line piping for grid systems. Do not assume the available water supply will be that identified with the existing design. Obtain current information.

6-8.1.2.2 Pipe Schedule Systems.

When the project modifies an existing pipe schedule system, determine the hazard classification and whether the existing cross and feed mains, and the riser pipe sizes can support the new piping and sprinklers. Identify the size of the pipe at the point of connection. Identify existing piping requiring replacement. Small renovations to existing pipe schedule systems may be designed by the pipe schedule method as permitted by NFPA 13 and up approval of the DFPE.

6-8.2 Fire Pumps.

Provide the following calculations verifying pump selection:

- Calculations supporting selected rated capacity and pressure.
- Power calculations for motor driven pumps.
- Fuel supply calculations for engine driven pumps.
- Calculations for suction supply tanks when applicable.

6-8.3 Special Systems.

\\ / /

6-8.3.1 Gaseous Fire Extinguishing Systems.

- Provide calculations verifying agent quantity, number of required tanks and intended tank location.
- When systems are installed in existing facilities, ensure a structural analysis is provided for the intended tank location as required.

6-8.4 Fire Alarm/Detection and Reporting Systems.

6-8.4.1 Modifications to Existing Systems.

- Provide a power supply analysis. Submit calculations for power supply and standby battery capacity requirements of existing system and new devices. Ensure the power supply is capable of supporting the electrical load of the new devices.
- Provide a circuit analysis. Ensure the panel has the initiating and signaling expansion capabilities.

CHAPTER 7 DELIVERABLE: DRAWINGS

7-1 GENERAL REQUIREMENTS.

Provide drawings in accordance with the Core UFCs, the contract, Chapter 12, and the additional Discipline requirements herein, for every stage of design. If another UFC adequately describes the requirement for a Discipline’s deliverable, a paragraph for that Discipline is not provided below.

7-2 BUILDING INFORMATION MANAGEMENT AND MODELING (BIM).

BIM is required on DB and AE-Designed DBB New Construction projects greater than \$1M and Major Renovation Projects greater than or equal to 50% of the Plant Replacement Value (PRV) at Navy Installations, Joint Bases, Department of Defense (DoD) Agencies, or Field Activities where NAVFAC is the Maintenance Provider, or when required by the contract. BIM is not required on Navy in-house-designed DBB projects.

The deliverables of BIM are outlined in Chapter 12. Use the Facilities Data Workbook (FDW), that prescribes the BIM Level of Detail (LOD) required by system or subsystem, with UFGS 01 78 24.00 20.

Table 7-1 BIM and FDW Requirements.

BIM/EOMSI By Service				
DELIVERABLE	NAVY	MARINE CORPS	AIR FORCE	USACE/ ARMY
BIM – 3D Parametric Model	REQUIRED	NOT APPLICABLE	NOT APPLICABLE	NOT APPLICABLE
eOMSI Facility Data Workbook	REQUIRED	NOT APPLICABLE	NOT APPLICABLE	NOT APPLICABLE
UFGS 01 78 23 eOMSI Manuals	REQUIRED	OPTIONAL*	OPTIONAL*	OPTIONAL*

*When required by contract.

7-3 PRESENTATION.

Drawings must be consistent in presentation and format. If one discipline shows material selections directly on the details, other disciplines must conform to that format, and not use numbers to refer to a numerical legend elsewhere on the drawings.

7-4 DRAWING NUMBERS.

Request NAVFAC drawing numbers from the Government Design Manager. Provide them with the following information:

1. The amount of numbers required;
2. The eProjects Work Order Number, and
3. The project title. Request enough numbers that additional sheets can be added if necessary (usually 10% more).

Only use the Maximo number, in lieu of eProjects Work Order Number, if eProjects is not required for the project.

7-5 PROPER USE OF NOTES ON DRAWINGS.

- Be consistent with grammar used in notes on drawings. Wherever possible use imperative statements to describe work to be accomplished by Contractor.
- Do not use "Contractor must provide," use "provide." It is understood that the notes are directed to the construction Contractor. The Contractor is responsible for performing the work as shown and specified; therefore, there is no reason to use the phrase.
- Do not use "to be" for describing work that will be accomplished by the Contractor. "To be" implies that someone will accomplish the work other than the Contractor, such as the Government or another Contractor. Similarly, do not use "proposed," as it can be interpreted to mean future work by others or work not in this contract. If work is to be accomplished by Government, for example, say "Government will remove storage building prior to start of construction."
- Do not use the term "furnish" unless only delivery of material to the site is required. Similarly, do not use the term "install" unless the Government or others will furnish equipment or materials and Contractor will install. Use "provide" to mean "furnish and install."
- Do not use "new" for work in the contract. Work shown on the drawings is considered new, unless indicated otherwise. Inconsistent use of "new" throughout the drawings could mean that only some of the work is required.
- Do not use vague words and phrases or escape clauses such as "in this specification," "as may be required," "as necessary," "an approved type," "as approved/directed/determined by the Contracting Officer," "first class workmanship," "securely," "thoroughly," "suitable," "properly," "good working order," "neatly," "carefully," and "installed in a neat and workmanlike manner."

- Be careful with statements like “remove and replace,” which means to remove old item or material and replace that item or material when work is completed. This statement would be appropriate for work in a pump station where pumps were removed prior to the work and those same pumps replaced after the work is completed. On the contrary, if a portion of a concrete walk is cracked and requires replacement, say “remove and provide concrete walk.”
- Use the term "Contracting Officer" when referring to requirement for coordination between Contractor and Government agency; do not use terms such as "Officer in Charge of Construction," "Contracting Officer Representative," "Government Representative," "Navy," "ROICC," or "PWD".
- Do not use the word "per", use "in accordance with" instead.
- Avoid the use of colloquial terms or jargon. For example, do not use "bulkhead" for wall, "deck" for floor, or "head" for toilet.
- Eliminate redundant wording such as "conforming to," "all," and "type." For example, when stating “paint doors”, **all** doors are implied.
- Do not use indefinite items such as "etc.," "any," and "and/or."
- Do not use long, compound, or hyphenated words such as "hereinbefore" and "hereinafter."
- Do not use words that have multiple meanings, requiring opinions, or judgmental decisions, such as “timely,” “nearly,” “good-condition,” “suitable,” “well-balanced,” “suitable for intended use,” “reasonable,” “approximately,” “reliable,” “proper,” “usable,” “appropriate,” “adequate,” or “qualified.”
- Do not use terms that are not biddable by the Contractor nor enforceable by the Government, such as “recondition,” “as directed,” “equal to,” “as required,” “similar to,” “as necessary,” “as close as possible,” “repair,” “match existing,” or “refurbish.”
- Some terms are only enforceable if quantities are shown on the drawings or included in the specifications, such as “as indicated,” “as shown,” “specified herein,” and “as noted.”
- Be careful when using the word, “typical,” especially if there are exceptions to the detail.
- Use “must” instead of “shall” to prescribe mandatory requirements, actions and procedures. “Shall” imposes an obligation to act, but may be confused with prediction of future action. “Must” imposes obligation and indicates a necessity to act.

- Do not use the word "should" in the specification text for mandatory requirements as "should" implies a recommendation. "Should" may be in the Notes to indicate desirable procedures that are advisory in nature.

7-6 CODE COMPLIANCE SUMMARY SHEET(S).

The Code Compliance Summary Sheet(s) must be prepared by the QFPE and must be included as "General Sheets" immediately following the title sheets. At a minimum, include the following information:

7-6.1 Building Code Site Plan.

Identify the following elements on the Building Code Site Plan:

- Line of encroachment identifying minimum separation distances from adjacent buildings and assumed property lines of the new construction and of the adjacent structures.
- Building perimeter used for frontage increases.
- Exit discharge paths.
- Fire Department vehicle access to building.
- Fire lane width, marking and locations, approach roads and turn radius and location.
- Intended fire department main entrance to building.
- Location of fire department connections.
- Fire hydrants, post indicator valve or valves and their connected water distribution mains serving building.
- Fire pump room.
- Water storage tanks.
- Hazardous material spill containment tanks.
- Backflow prevention assembly or assemblies serving water-based fire protection systems (if located outside of building).

7-6.2 Building Code Summary.

Identify each of the following elements in the Building Code Summary:

- Classification of occupancy.
- Allowed vs. provided type of construction.
- Basic allowable heights & areas vs. actual heights & areas.
- Allowable vs. provided height or area increases per floor and total.

- Calculations supporting height and area modifications/increases.
- Required vs. provided exterior exposure protection.
- Required vs. provided interior fire rated occupancy separations.
- Required vs. provided internal fire area separations.
- US Required vs Host Nation Required vs Provided (for OCONUS projects only).

7-6.3 Life Safety Code® Summary.

Identify the following elements in the Life Safety Code® Summary:

- Classification of occupancy of each room, area or compartment (on the drawings or in tabular form);
- Occupant load factor(s) and total calculated load;
- Required vs. provided number of exits;
- Required vs. provided capacity of means of egress;
- Required vs. provided arrangement of means of egress including remoteness of exits, horizontal exits, travel distance, common path of travel, dead-end corridor lengths. When suites are used, indicate type, location, area and arrangement;
- Required vs. provided accessible means of egress;
- Required vs. provided discharge from exits;
- Required vs. provided fire rated separation of exits and exit access;
- Required vs. provided fire rated separation of hazardous areas;
- Flame spread/smoke development ratings of interior finishes;
- Requirements (if any) for smoke control systems based on the specific occupancy chapter and building design considerations;
- Requirements for special locking arrangements such as delayed-egress locks or access-controlled egress doors. Specify the rooms/area.
- US Required vs Host Nation Required vs Provided (for OCONUS projects only).

7-6.4 Life Safety Plans.

The Life Safety Plans must be prepared by the QFPE and must be included as “General Sheets” immediately following the title sheets and code compliance summary sheets. Scale the floor plans so the entire footprint fits on a single sheet provided that information is clearly legible, and the scale is no smaller than 1/16-inch (1:200). At a minimum, include the following information:

- Location and rating of fire walls, fire barriers, fire partitions, smoke barriers and smoke partitions (both horizontal and vertical). Barriers requiring fire resistance rated supporting construction must be specifically identified for coordination with the structural design partition locations with fire rated partitions and horizontal exits identified.
- Building areas having different occupancy and hazard classifications.
- Room numbers, corresponding occupancy classification and calculated occupant load. Include occupant load of each room, area, or compartment (on the drawings or in tabular form). Similar occupancies can be grouped together for occupant load calculations.
- Capacity and number of occupants using each major means of egress component (such as stairs, stair doors, exterior doors, assembly exit doors.)
- Rooms or areas requiring special life safety or fire protection features.
- Location of hazardous materials storage, handling and use that exceed the maximum allowable quantities.
- Egress travel requirements (such as travel distances, common paths of travel, dead-end corridors).
- Structural fireproofing locations and associated ratings.
- When required, fire extinguisher cabinet and surface-mounted fire extinguisher locations.
- When required, fire extinguisher type/quantity table identifying the total number and type of extinguishers required.
- Location of primary fire alarm/mass notification control panel.

7-7 CIVIL DRAWINGS.

7-7.1 Cover Sheet, Drawing Index, Vicinity Map, Location Plan, Abbreviations, Legend, and Notes, or First Civil Sheet.

If project is not a Civil Engineering lead, assure that the following items are coordinated with the lead discipline responsible for creating cover sheet:

- a. If General Development Maps (GDM) are used for the Vicinity and Location Maps, edit for the specific project being designed. Ensure street names, main gates, and the Public Works office of the base are identified. Ensure that text is legible at the plotted scale and remove extraneous lines.
- b. The Vicinity Map must identify the Activity and have enough main highway names and street names to allow an out-of-town contractor to locate the work.

- c. The Location Plan must allow the contractor to find the project on the base. This is generally a good place to show laydown areas, haul routes, construction traffic routing restrictions, and off-site benchmark locations. Provide street names to allow coordination between the Vicinity Map and the construction plans.
- d. In general, it is desirable to show the Vicinity Map and the location Plan on the Cover Sheet along with the project title.
- e. Coordinate with Contracting Officer and Activity for laydown area.
- f. Edit standard details, abbreviations, legends, and general notes for the specific project being designed.
- g. Provide a single Civil legend on one sheet (preferably sheet C-001).
- h. Datum must be securely tied between project datum and local datum.
- i. For projects near tidal waters, show datum sketch indicating project vertical datum and relationship to range of tide and other important datum.

7-7.2 Demolition Plan.

Include the following:

- a. Clearly show what is to be demolished at an appropriate scale. Coordinate/edit the legend to match the demolition plans.
- b. Indicate the beginning and ending points of utility removals and methods of plugging pipes (such as cap, brick & mortar). Show locations of valves to be used for isolating work.
- c. Show limit of pavement removal and pavement thickness.
- d. Describe the existing items in detail with supplemental descriptions if necessary. Indicate depth of pavements/bases to allow uniform contractor bids.
- e. Provide a sequence of demolition if necessary. Include known requirement for continuous operation and limited shutdown requirements. These must be identified in the special scheduling paragraphs of the specification.
- f. Do not show items that are being demolished with the current project on subsequent Civil plan sheets.
- g. Show locations of erosion and sediment (E&S) control items and add E&S notes. Show erosion control details on drawings or refer to applicable details in the State Erosion and Sediment Control Handbook or manual. Verify that the erosion control legend is edited, clear and coordinated with the drawings.

- h. Provide a Tree Protection Detail for existing trees, which are to be preserved during construction. Trees are not amenable to the same barrier fence application. Consult a Registered Landscape Architect or State Certified Arborist. As a minimum, show a 4 foot (1.2 m)- high safety-orange, plastic barrier fence with metal or 4 x 4 inch (101 x 101 mm) wood stakes at 8 foot (2.5 m) on center spacing, continuously located around the tree's drip-line, unless otherwise directed by a certified arborist. If trees are in a group or cluster, use only one fence to surround the entire cluster.

7-7.3 Site Plan.

Include the following:

- a. Show aboveground features including features required by the BOD (examples: airfields, railroads, crane rail, small arms ranges) with adequate layout data and existing aboveground features, after demolition has occurred.
- b. Label baselines to be used for project layout as 'construction baseline' as opposed to survey baseline.
- c. Provide layout dimensions from the construction baseline, or another readily identified (and easily established) alignment in the field. Include horizontal control point locations and descriptions. Use of coordinates for layout purposes is discouraged, however their use may be considered on a case-by-case basis. Contact Government's Civil Reviewer for approval of coordinate layout prior to project submittal.
- d. Show areas requiring pavement patching, repairs, and pavement. Provide pavement jointing plans for rigid pavements. Include separate pavement marking plans for airfield projects.
- e. Eliminate extraneous items that may congest the drawing (such as contours, elevations) and detract from the layout information.
- f. Show locations of additional E&S control items not already included on the Demolition Plan. Coordinate with E&S notes, details, and legend.
- g. Indicate trees and plant material to remain.
- h. Provide statement concerning location of soil borings and soil information.

7-7.4 Water and Sanitary Sewer Plan.

Include the following:

- a. Indicate whether connections will be made by wet tap (tapping sleeve/valve) or by dry connection. Show nearest valve(s) for system

isolation if the latter is the case. Indicate known scheduling issues in the special scheduling paragraphs of the specification.

- b. Indicate surface materials (such as grass, bituminous, or concrete).
- c. Provide numbers (or letters) for each sanitary structure and water fitting so that plans and profiles are easily coordinated. This labeling system must be clearly distinct from that used for the storm drainage system and preferably distinct from labels used by other utility systems (such as electrical).
- d. Provide manhole rim and invert elevations, pipe slopes, pipe diameters and pipe materials. If profiles are provided, indicate slopes on the profile sheets and do not provide on the plan sheets.
- e. For water treatment plants, provide details process and instrumentation diagram (P&ID).
- f. Provide reference to drawings and specifications for cathodic protection of fire protection water storage tanks, piping, or water lines, including metallic components of non-metallic lines (for example, PIVs, fire hydrants, change of direction devices, and valves).

7-7.5 Water, Storm, and Sanitary Sewer Profiles.

- a. Show profiles where needed for clarity and to avoid potential conflicts. Discuss profile requirements with Government's Civil Reviewer.
- b. Indicate structure tops, pipe invert elevations, slopes, lengths, and diameters of gravity lines.
- c. Coordinate structure numbers with plan sheets.
- d. Reference the plan sheets where pipes/structures are shown.
- e. Show and label existing and surface materials, such as concrete pads, curbs, and roads, traversed by the lines. Accurately show depth of existing pavements.
- f. Show and label crossing utility lines, both existing and new.
- g. If depths of existing utilities are unknown, indicate the horizontal location of the utility and indicate the vertical location with a line representing the anticipated range of elevations where the utility will be found in the field. Indicate the method of utility installation routing above or below conflicts (such as concrete encasement or pressure pipe).

7-7.6 Grading and Drainage Plan.

Include the following information:

- a. Provide existing spot elevations and existing contours at intervals to clearly indicate existing drainage patterns.
- b. Provide spot elevations and contours when appropriate to clearly indicate grading and drainage patterns. Spot elevations/contours must be easily distinguished (bolder font) from existing.
- c. Indicate where grading ties to existing grading (limits) and verify that work will not block existing adjacent drainage.
- d. Show benchmarks, temporary benchmarks (tbm's), other vertical control, and datum notes on this plan.
- e. Show finish floor elevations on grading plans. Do not show finish floor elevations on the architectural or structural plans in order to avoid conflicts. Coordinate adjacent exterior grading with the architectural/structural plans to ensure positive drainage patterns away from the building.
- f. Verify that the slopes indicated on the plans are suitable for the surface material involved (such as earth slopes, bituminous pavements, and concrete pavements. Consider if these slopes are maintainable for the service life of the facility.
- g. Coordinate with the Landscaping Plans (L sheets) to prevent plantings from blocking site drainage.
- h. Provide numbers (or letters) for each drainage structure so that plans and profiles are easily coordinated.
- i. Provide erosion and sediment control details.

7-7.7 Site / Utility Details.

Incorporate details as follows:

- a. If applicable, edit and update standard details provided by the Government's Civil Reviewer to apply to the particular conditions and requirements of the project.
- b. Details of items shown in the construction standards of the Department of Transportation, or other agencies of the state in which the project will be constructed, or other appropriate local/commercial standards are required on the plans.
- c. Pavement Sections.

7-8 LANDSCAPE ARCHITECTURAL DRAWINGS.

7-8.1 Landscape Demolition Plan.

Coordinate existing site improvements and existing trees or other plant materials to be demolished with Civil Engineer. If a Civil Engineer is not involved with the project, conform to the requirements listed in Civil Drawings section under Demolition Plan.

7-8.2 Landscape Site Plan.

Coordinate site improvements with Civil Engineer. For projects with detailed Landscape Architectural features provide a Landscape Site Plan. Include the following:

- a. Show new aboveground features including features required by the BOD (examples: buildings, existing site features to remain, utilities and other infrastructure improvements, vehicular and pedestrian circulation, parking, hardscape, fire lanes, Indicate hardscape, plazas, courtyards, child play equipment, monuments, memorials, site furniture, fences, walls, trash enclosure, signage, landscape drainage, and other site structures, streetscapes, LID and other bio-retention features, and AT standoff distances) and unobstructed space with adequate layout data and existing aboveground features, after demolition has occurred. Provide enlargement plans to delineate appropriate detail in plan view.
- b. Label baselines to be used for detailed Landscape Architectural features layout as 'construction baseline' as opposed to survey baseline.
- c. Provide layout dimensions from the construction baseline, or another readily identified (and easily established) alignment in the field. Include horizontal control point locations and descriptions. Use of coordinates for layout purposes is discouraged, however their use may be considered on a case-by-case basis. Contact Government's Landscape Architectural Reviewer for approval of coordinate layout prior to project submittal.
- d. Eliminate extraneous items that may congest the drawing (such as contours, elevations) and detract from the layout information.

7-8.3 Landscape Construction Details.

Provide details, sections, and elevations for site improvements required for construction.

7-8.4 Landscape Planting Plan.

Show locations of facilities (such as buildings, parking areas, roads, sidewalks, plazas or patios, existing vegetation to remain, and other surface improvements) and new

plantings (such as trees, shrubs, ground cover), LID features, and bio-retention treatments.

7-8.5 Plant Material Schedule and Details.

Include the following:

- Provide a schedule for plant material showing as a minimum: botanical name, common name, quantity of plants, tree trunk caliper, minimum height and spread at time of planting, root condition (for example, balled and burlapped, containerized, and boxed), and a keyed reference to a planting detail.
- Provide separate details for plant types (such as trees, shrubs, ground covers) and other elements (such as root barrier, headers or edging, mulching).

7-8.6 Landscape Irrigation Plan.

When a Landscape Irrigation Plan is required by the Statement of Work, show locations of facilities (such as buildings, parking areas, roads, sidewalks, plazas and patios, existing vegetation to remain, and other surface improvements). Show pressure pipe and lateral lines, sprinkler heads, drip tubing and emitters, valves, backflow preventers, water source connections, wells, rain sensors, automatic controllers, rainwater harvesting (and other sustainable design features), and similar items.

7-8.7 Irrigation Equipment Schedule and Details.

When a Landscape Irrigation Plan is required by the Statement of Work, include the following:

- Provide an Irrigation Equipment Schedule showing at a minimum: graphic symbol, description of the item, manufacturer, model number, irrigation nozzle type (for example, full, half, quarter, or bubbler), optimum nozzle pressure (PSI), nozzle radius, and nozzle flow (GPM).
- Provide separate details for irrigation equipment (such as sprinkler heads, automatic controller, backflow preventer, valves, and other accessories).
- Provide pressure loss calculations.
- Provide water budget watering schedule, and equipment manufacturer's specifications, operations, and other information.

7-9 GEOTECHNICAL DRAWINGS.

Include subsurface investigation results on the drawings for record-keeping purposes. As a minimum, the drawings must include each of the logs/records as they appear in the Geotechnical Report; a summary table of the laboratory testing results; legend and descriptive notes concerning the drilling, logs and testing; groundwater level

observations/conclusions; and site preparation notes and details, such as undercutting and surcharging. Include accurate figures showing the testing locations in the geotechnical drawings, or preferably, show the testing locations in the existing conditions or civil drawings.

7-10 STRUCTURAL DRAWINGS AND NOTES.

Provide structural drawings that sufficiently detail the structural work. The drawings must contain a set of “Structural Notes” in accordance with UFC 1-200-01, and which provide critical reference information for future building modifications or evaluations. As a minimum, note Design Criteria, Design Standard References, General Construction requirements, and the following:

- **Loads:** Provide loading information and identify sources for listed loads.
- **Foundation Conditions:** Fully describe the foundation conditions and list the type of foundation system and method employed to determine allowable soil bearing values. Indicate the minimum allowable bearing capacity for shallow foundations, or the pile or pier capacity in both tension and compression for deep foundations. Indicate passive, active and at rest design pressures, the coefficient of friction and the sub-grade modulus. Indicate if a site-specific design spectrum is to be used in the design and give the site class in accordance with the seismic design criteria used.
- **Materials:** Clearly define the types, grades, and properties of materials for each structural element and system.
- **Quality Assurance:** Provide a summary of the quality assurance requirements.
- **Ammunition and Explosive Facilities:** Drawings that include a standard approved for Ammunition and Explosive storage facilities must include a note clearly identifying the source, name, and date of the standard design.
- **Marine Structures:** List mooring berthing and deck loads for marine structures, including ship classes (such as DDG 51, CG 47, CVN) with associated displacements.

7-11 FIRE PROTECTION.

Provide floor plans showing the following information. Scale the floor plan so the entire footprint fits on a single sheet provided that information is clearly legible, and the scale is no smaller than 1:200 or 1/16-inch. Where a building has multiple hazard classifications or areas protected with special fire suppression systems, differentiate each area by border or hatching.

Information pertaining to electronic control/release systems may be shown on the Fire Alarm/Mass Notification Systems drawings specified below.

7-11.1 Fire Sprinkler Systems.

Provide the following information:

- Locations of sprinkler riser room.
- Fire department connections.
- Post indicator valves.
- Isolation control valves.
- Sprinkler branch lines or feed main piping if a specific routing is required, such as single feed to computer room or elevator equipment room and hoistway.
- Location of control panels used for release of pre-action or deluge systems.
- Fire pump and associated equipment.

7-11.2 Gaseous Fire Extinguishing Systems.

Provide the following information:

- Outline of area/hazard to be protected.
- Location of storage cylinders and releasing panel.
- System initiating devices (such as manual releases, automatic detection devices).
- Notification appliances.
- Main/reserve transfer switches.
- Control devices such as dampers, shunt trip breakers for computer equipment shutdown, and air conditioning units to be shut down, and electromagnetic door hold-open devices.

11/11

7-11.3 Fire Suppression Detail Sheets.

Provide fire suppression detail sheets showing the following information:

7-11.3.1 Fire Sprinkler Systems.

- Enlarged plan view of sprinkler riser room showing sprinkler risers, control valves, backflow prevention device and service entrance (supply) manifold drawn to scale.
- Cross-sectional elevations of sprinkler and standpipe risers.
- Enlarged plan view of fire pumps and piping arrangement, jockey pump, and associated controllers and equipment drawn to scale.
- Cross-sectional elevations of fire pump supply and discharge piping arrangement.
- Releasing system riser diagram for pre-action or deluge sprinkler systems. Identify zones, circuit inputs and circuit outputs necessary for controls, including interconnection with building fire alarm control panel.

7-11.3.2 Gaseous Fire Extinguishing Systems.

- Releasing system riser diagram identifying zones, circuit inputs and circuit outputs necessary for controls, including interconnection with building fire alarm control panel.
- Elevation view of storage cylinders and manifold.
- Isometric detail drawing of agent distribution piping including storage cylinder manifold and discharge nozzles.
- Sequence of Operation Matrix. See NFPA 72 for sample.

V1\1/

7-11.4 Fire Alarm/Mass Notification System Plans.

Provide floor plans identifying location of field installed components and interconnected devices. Plans may identify fire suppression control/release system information identified above. At a minimum, identify the location of the following information:

- Control panel(s).
- Notification appliance circuit extender panels.
- Radio transmitter or master box.
- Line and low voltage surge arrestors.
- Initiating devices (including duct smoke detectors). In lieu of locating devices on the plans, and as authorized by the DFPE, provide the following information on the plans:
 - Ambient sound pressure levels and audible design sound pressure levels

- Area boarders or other means to identify differing distinguishable spaces (ADS)
- Area borders to indicate the type of detection system, initiating devices, notification appliances and releasing service
- Area borders for detection and notification zones
- Rooms and spaces that will have visible notification and those where visible notification will not be provided
- Rooms and spaces that will have initiating devices and the design performance requirements for those devices
- Supplemental equipment interfaced with the fire alarm system such as voice evacuation panels, electromagnetic door holders, delayed-egress or access-controlled doors, elevator system components.
- Supplemental fire suppression equipment control panels such as fire\1\ /1/ pump controllers, Fire suppression control/release panels.

7-11.5 Fire Alarm/Mass Notification System Detail Sheets.

Detail sheets may identify fire suppression control/release system information identified above.

7-11.5.1 Riser Diagram.

Provide a riser diagram showing hierarchy, arrangement, and zoning of the system. Identify typical circuits, interconnections, and interlocks necessary for associated controls. Do not identify every field device individually, such as smoke and heat detectors. Identify required line and low voltage surge arrestors. Interface with security systems for required delayed-egress or access-controlled doors. Identify interface with fire suppression control/release panels.

7-11.5.2 Sequence of Operation Matrix.

See NFPA 72 for sample.

7-12 DRAWINGS PREPARED FOR OTHER GOVERNMENT ORGANIZATIONS.

Approval of drawings for projects of other Government organizations or approval of modifications or revisions of drawings prepared by such organizations is required as follows:

- Indicate approval by other Government departments or agencies by appropriate signature in the supplemental locations provided on the NAVFAC Title Block (in accordance with Chapter 12).

- When NAVFAC drawings are prepared for construction projects for other Government departments or agencies, submit fully developed concept designs to the appropriate departments or agencies for formal approval.
- For drawings prepared under the direction of NAVFAC, the other Government organization provides approval solely for functional and operational sufficiency.
- When definitive, standard, or project drawings of other Government departments or agencies are used by NAVFAC for design of projects for those departments or agencies, make modifications or revisions to such drawings only with the approval of the department or agency concerned, unless NAVFAC has been authorized otherwise.

This Page Intentionally Left Blank

CHAPTER 8 DELIVERABLE: SPECIFICATIONS

8-1 GENERAL REQUIREMENTS.

Provide specifications in accordance with UFC 1-200-01, the Core UFCs, UFC 1-300-02, and Chapter 12. Provide specifications that are as brief as possible, definitive, and free of ambiguities and omissions that may result in controversy and contractor claims for additional compensation.

8-2 GUIDE SPECIFICATIONS.

Specifications offer criteria for materials, equipment, and test methods. Guide specifications are documents that describe products and materials and the work necessary to incorporate them into a construction project. A guide specification facilitates the preparation of project specifications by standardizing products and processes, and their order of presentation. DoD uses the Unified Facilities Guide Specifications (UFGS) database, provided on the WBDG (<https://www.wbdg.org>), which is updated quarterly. Edit guide specifications to specific project requirements for incorporation into the contract documents. Guide specification and project specification sections describe the following in detail:

- Product or system to be provided,
- Salient design features or performance requirements of the product or system,
- Quality of that product or system and methods used to ensure the quality, including on-site and off-site testing,
- Method to be used to incorporate the product or system into the project, and
- Other features and functions necessary.

Guide specification section numbers, up to 10 digits, in CSI MasterFormat®, are grouped in pairs. Each of these groupings is referred to as a “level,” from one to five. Refer to CSI MasterFormat® (<https://www.csiresources.org/standards/masterformat/masterformat-number>) for further explanation.

8-2.1 Unified Facilities Guide Specifications (UFGS).

Use Unified Facilities Guide Specifications (UFGS) for projects, including DB. UFGS are available at the WBDG (<https://www.wbdg.org/>). Tailor and modify the UFGS to suit the work required by the specific project, including editing for metric or inch-pound. In addition, modify and edit to reflect the latest proven technology, materials, and methods, for the project.

There is only one current version of a guide specification at any time. The guide specification with the latest revision date and change number automatically cancels specifications of the same number with a previous date and change number.

8-2.2 Regional Guide Specifications.

Some Supported Commands have modified some of the UFGS for their region; these are referred to as Regional Guide Specifications. Use Regional Guide Specifications when sections are available by the Region and Activity for the project location, and in accordance with the contract. Regional specifications are located on the WBDG (<https://www.wbdg.org/navy/nfqs>) and where indicated in the contract.

Regional specifications are limited in number and scope to selected subjects particular to a location and contain a majority of local requirements. Regional specifications are used in the same way as the UFGS except that they are used only in the area of the specific facility engineering command jurisdiction. Regional specifications are numbered the same as the UFGS that has been used as a basis for the regional specification, with the exception of a regional designation at the fifth level for specifications in CSI MasterFormat®; for example, in UFGS Section number, 01 13 30.00 22, “22” indicates the region. Assigned regional designations can be found with the Regional specifications on the WBDG (<https://www.wbdg.org/navy/nfqs>).

8-2.3 Other Guide Specifications.

Other guide specifications are only allowed as a basis for information when not available in the UFGS. These developed specifications must be provided in UFGS format and modified to meet requirements of UFC 1-300-02.

8-2.4 UFGS Selection Order of Precedence.

Unless specified otherwise in the contract, the order of precedence for selecting which UFGS to start from, for CONUS jobs that require the use of the UFGS, is as follows:

1. Regional Guide Specifications (for the project location and where sections are published on WBDG).
2. UFGS, Navy only (UFGS with a “20” at the fifth level in CSI MasterFormat®).
3. UFGS (unified, no designator at the fifth level).
4. Other DoD UFGS (Army UFGS with .00 10 designation and modified for Navy job).

8-2.5 DB Performance Technical Specifications.

Develop Performance Technical Specification (PTS) sections in accordance with requirements of Chapter 11.

8-3 PROJECT PREPARATION POLICIES AND GUIDANCE.

Prepare specifications in Format and Styles required by UFC 1-300-02.

8-3.1 UFGS Version Date.

Download, use, and edit the most current UFGS database available from the WBDG (<https://www.wbdg.org/dod/ufigs>). Unless otherwise specified by the contract, the version that is current at the official start of the Pre-Final design phase for DBB must be used; or the version current at the last phase of RFP issuance for DB; and continue to be used, through Final design. Coordinate the version of the UFGS database used with the Government Design Manager and report this date to them.

8-3.2 Editing of Specifications for Project.

Modify and edit the guide specification to fit the project and to meet UFC requirements. Follow the Notes to the Designer to make selections in the UFGS. Use language and format in accordance with UFC 1-300-02. Delete portions of the guide specification not included in the project design and scope.

Use guide specifications only as source documents, and do not reference them in project specifications. Do not combine work covered by various UFGSs into one section unless the project is small and work is of a minor nature, and the Government Design Manager concurs.

8-3.2.1 Geotechnical and Civil Specifications.

Do not edit outside of the guide specification's bracketed selections for Geotechnical and Civil UFGS sections in Divisions 11 31, 32, and 34 /1/ without prior approval of the Government Design Manager.

8-3.3 Standard Plates, Sketches, and Details.

Provide plates, sketches, boring logs, and details on the drawings, and not in the specifications.

8-3.4 Unrestricted Bidding.

Provide only the actual minimum needs of the Government in the specifications and describe the salient characteristics of materials and installation so as to encourage maximum competition in bidding. Eliminate, insofar as possible, restrictive features that might limit acceptable offers to one supplier's product, or to the products of a relatively few suppliers, and in accordance with UFC 1-300-02. Do not list manufacturers unless

Contracting Officer approval is received in accordance with NFAS 6.304. Master UFGSs that list manufacturers must have a class justification on file.

8-3.5 Contract Parties.

Do not designate part of the work to be performed by a particular subcontractor (such as the plumbing contractor) in constructing the project, except for some specific instances. The Government recognizes only one Contractor (the prime or general contractor) and it is the Contractor's responsibility to divide up the work.

8-3.6 Facilities Electronic Operation and Maintenance Systems Information (eOMSI).

eOMSI (UFGS 01 78 24.00 20) is required on New Construction projects greater than or equal to \$1 Million and Major Renovation Projects greater than or equal to 50 percent of the Plant Replacement Value (PRV), at Navy and Marine Corps Installations Joint Bases, Department of Defense (DoD) Agencies, or Field Activities, where NAVFAC is the maintenance provider of the facility. Also, use UFGS 01 78 24.00 20 for projects using BIM or when required by the contract. Use both UFGS 01 78 23 and UFGS 01 78 24.00 20.

The eOMSI Facility Data Workbook (FDW) is required for facilities operated and maintained by NAVFAC and Marine Corps. For BIM projects, use the FDW to prescribe the Level of Detail.

8-4 COORDINATION OF SPECIFICATIONS AND DRAWINGS.

FAR 52.236-21 states: "Where 'as shown', 'as indicated', 'as detailed', or words of similar import are used, the reference is made to the drawings accompanying this contract unless stated otherwise."

8-4.1 DBB Contract Order of Precedence.

For DBB contracts, the Contract Order of Precedence is defined in FAR 52.236-21. In general, treat anything mentioned in the specifications but not shown on the drawings or shown on the drawings but not included in the specifications, as if shown or mentioned in both. In the case of discrepancies between the drawings and specifications, the specifications take precedence.

8-4.2 DB Contract Order of Precedence.

Refer to the RFP and the contract for Order of Precedence on DB contracts.

8-4.3 Coordination.

Coordinate the drawings and the specifications to ensure that items depicted in the drawings are covered by an appropriate specification section and that specification sections relate to items in the drawings.

8-5 USE OF UFGS AND SPECSINTACT.

Edit and provide UFGS sections in accordance with UFC 1-300-02, using SpecsIntact software and UFGS format. SpecsIntact is the word processing software used to edit the UFGS database. SpecsIntact software is available for download, free of charge, at the SpecsIntact website (<https://specsintact.wbdg.org/>).

8-6 SPECIFICATIONS PACKAGE ORGANIZING STRUCTURE.

8-6.1 Coversheet.

Include an overall cover sheet, for signature, with project specification package. Type in the name and title of the principal DOR, who must sign in the “Submitted By” location. The coversheet for electronic signature is available on the WBDG (<https://www.wbdg.org/navy/project-information-form-specifications-cover-sheet/spec-coversheet>).

Use the eProjects Work Order Number; only use the Maximo number on coversheet and other project documents if eProjects is not required for the project.

8-6.2 Contract Documents.

The DOR prepares and provides the following documents to the Government’s Project Manager for the Contract Specialist. The Contract Specialist consolidates bidding and contract requirements, along with the drawings and specifications, into a single solicitation package.

8-6.2.1 Project Synopsis.

The scope in the project synopsis is taken from the Description of Work located in UFGS Section 01 11 00. This description of work must be concise, and summarize the location, facilities, and type of work involved. A sample synopsis is provided in Appendix A. Provide the scope of work for the Synopsis at Pre-Final and Final in accordance with contract requirements.

8-6.3 Format.

Provide specifications in UFGS format in accordance with UFC 1-300-02. Print job headers with the job title, exactly as it appears on the drawings, justified to the left, and with the eProjects Work Order Number justified to the right. For Prefinal submittals, follow the job title with “(Prefinal).”

8-6.4 General Requirements (Division 00 and 01) Specifications.

Edit the UFGS Division 00 and 01, General Requirements Divisions, to describe the general project requirements of the project. Provide additional requirements of a general nature, rather than of a technical nature, in General Requirements.

The UFGS sections in Table 8-1 are typically used in a DBB project. Use other Division 01 sections as required, depending on the scope of the project, or in accordance with the Contract. Provide UFGS Document 00 01 15 as part of the specifications package, or separately, in accordance with Contract requirements.

Table 8-1 Commonly Used DBB UFGS Division 00 and 01 Sections

UFGS Number	TITLE
00 01 15	LIST OF DRAWINGS (sometimes not provided in TOC)
01 11 00	SUMMARY OF WORK
01 14 00	WORK RESTRICTIONS
01 20 00	PRICE AND PAYMENT PROCEDURES
01 30 00	ADMINISTRATIVE REQUIREMENTS
01 32 17.00 20	COST-LOADED NETWORK ANALYSIS SCHEDULES (NAS)
01 33 00	SUBMITTAL PROCEDURES (attach Submittal Register)
01 33 29	SUSTAINABILITY REQUIREMENTS AND REPORTING
01 35 26	GOVERNMENTAL SAFETY REQUIREMENTS
01 42 00	SOURCES FOR REFERENCE PUBLICATIONS
01 45 00	QUALITY CONTROL
01 50 00	TEMPORARY CONSTRUCTION FACILITIES AND CONTROLS
01 57 19	TEMPORARY ENVIRONMENTAL CONTROLS
01 58 00	PROJECT IDENTIFICATION (attach Project Signboards)
01 78 00	CLOSEOUT SUBMITTALS
01 78 23	OPERATION AND MAINTENANCE DATA
01 78 24.00 20	FACILITY DATA WORKBOOK (FDW) (attach Facility Data Workbook)

8-6.5 DB RFP.

For Part 2, “General Requirements,” of the six part DB RFP, use the UFGS sections provided in Part Two of the NAVFAC DB Master on the WBDG (<https://www.wbdg.org/navy/ndbm>) as appropriate. Table 8-2 shows commonly used DB RFP Part Two UFGS sections.

Table 8-2 Commonly Used DB RFP PART Two UFGS Division 01 Sections

UFGS Number	TITLE
01 14 00	WORK RESTRICTIONS
01 20 00	PRICE AND PAYMENT PROCEDURES
01 30 00	ADMINISTRATIVE REQUIREMENTS
01 31 19.05 20	CONCEPT DESIGN WORKSHOP (CDW)
01 32 17.00 20	COST-LOADED NETWORK ANALYSIS SCHEDULES (NAS)
01 33 00.05 20	CONSTRUCTION SUBMITTAL PROCEDURES
01 33 10.05 20	DESIGN SUBMITTAL PROCEDURES
01 33 29	SUSTAINABILITY REQUIREMENTS AND REPORTING
01 35 13	SPECIAL PROJECT PROCEDURES
01 35 26	GOVERNMENTAL SAFETY REQUIREMENTS
01 45 00	QUALITY CONTROL
01 50 00	TEMPORARY CONSTRUCTION FACILITIES AND CONTROLS
01 57 19	TEMPORARY ENVIRONMENTAL CONTROLS
01 74 19	CONSTRUCTION WASTE MANAGEMENT AND DISPOSAL
01 78 23	OPERATION AND MAINTENANCE DATA
01 78 24.00 20	FACILITY DATA WORKBOOK (FDW)

8-6.6 Project Reports.

Many projects include special requirements due to the presence of environmentally sensitive materials, such as asbestos, lead containing paint, PCBs, or other hazardous materials. Typically, as part of the Design or RFP Development contract, investigations are conducted to determine the presence, levels, and limits of sensitive materials. The investigative firm then provides reports, from which the information is used to design the project or provided in the DB RFP. The Government provides this information to the Contractor as part of the contract documents.

8-6.6.1 DBB.

Provide and attach reports to the end of the appropriate UFGS specification section (example: provide the asbestos report at the end of UFGS 02 82 00 *Asbestos Remediation*).

8-6.6.2 DB.

For DB, provide project reports in Part 6 of the RFP.

8-6.7 Combining Multiple Projects into One Bid Package.

Occasionally, several projects that have been independently prepared, or need to be easily separated, will be combined into one solicitation package. One solution is to combine the packages into at least three Parts.

8-6.7.1 DBB Parts.

In Part A, provide one General Requirements (Division 01) specification for the entire package. This Division 01 must be edited and accurate for the combined projects. The header in Part A must list the titles of each project, justified to the left, and the corresponding eProjects Work Order Number for each project, justified to the right. Example is provided in Figure 8-1.

Part B consists of the technical specifications (Divisions 02-49) for the first project and Part C consists of the technical specifications for the second project. Add additional parts depending on the number of projects being combined. Provide a Divider, a Table of Contents, and the technical specification sections. The header in each part must contain only the title of that Project and the corresponding eProjects Work Order Number for that project. An example is provided in Figure 8-1.

Figure 8-1 Sample Table of Contents for Combined DBB Projects

GATE 5 SECURITY IMPROVEMENTS, NSA NORFOLK	222088
SECURITY IMPROVEMENTS, GATE 10, NAS OCEANA	235341
PROJECT TABLE OF CONTENTS	
PART A: GENERAL REQUIREMENTS	
DIVISION 00	
00 01 15	LIST OF DRAWINGS
	PART B LIST OF DRAWINGS
	PART C LIST OF DRAWINGS
DIVISION 01 - GENERAL REQUIREMENTS	
01 11 00	SUMMARY OF WORK
01 14 00	WORK RESTRICTIONS
01 20 00	PRICE AND PAYMENT PROCEDURES
01 30 00	ADMINISTRATIVE REQUIREMENTS
01 32 17.00 20	COST-LOADED NETWORK ANALYSIS SCHEDULES (NAS)
01 33 00	SUBMITTAL PROCEDURES
	SUBMITTAL REGISTER PART A
	SUBMITTAL REGISTER PART B
	SUBMITTAL REGISTER PART C
01 33 29	SUSTAINABILITY REQUIREMENTS AND REPORTING
01 35 26	GOVERNMENTAL SAFETY REQUIREMENTS
01 45 00	QUALITY CONTROL
01 50 00	TEMPORARY CONSTRUCTION FACILITIES AND CONTROLS
01 57 19	TEMPORARY ENVIRONMENTAL CONTROLS
01 57 19.01 20	SUPPLEMENTAL TEMPORARY ENVIRONMENTAL CONTROLS FOR GATE 5
01 57 19.02 20	SUPPLEMENTAL TEMPORARY ENVIRONMENTAL CONTROLS FOR GATE 10
01 58 00	PROJECT IDENTIFICATION
01 78 00	CLOSEOUT SUBMITTALS
01 78 23	OPERATION AND MAINTENANCE DATA
01 78 24.00 20	FACILITY DATA WORKBOOK (FDW)
-- End of Part A --	
PART B: GATE 5 SECURITY IMPROVEMENTS, NSA, NORFOLK, VA (WON 222088)	
02 41 00	[DEMOLITION] [AND] [DECONSTRUCTION]
DIVISION 26 - ELECTRICAL	
26 08 00	APPARATUS INSPECTION AND TESTING
26 32 15.00	ENGINE-GENERATOR SET STATIONARY 15-2500 KW, WITH AUXILIARIES
DIVISION 31 - EARTHWORK	
31 00 00	EARTHWORK

DIVISION 34 - TRANSPORTATION

34 71 13.19 CRASH RATED ACTIVE VEHICLE BARRIERS AND CONTROLS

-- End of Part B --

PART C: SECURITY IMPROVEMENTS GATE 10, NAS OCEANA, VIRGINIA BEACH, VA (WON 235341)

DIVISION 02 - SITE WORK

02 41 00 [DEMOLITION][AND][DECONSTRUCTION]

DIVISION 31 - EARTHWORK

31 23 00.00 20 EXCAVATION AND FILL

DIVISION 08 - OPENINGS

08 11 13 STEEL DOORS AND FRAMES

08 71 00 DOOR HARDWARE

-- End of Part C -

8-6.7.2 DB Parts.

Part A consists of the General Requirements Division (Division 01), Part B consists of the RFP (Parts 3-6) for the first project, and Part C consists of the RFP for the second project. Add additional parts depending on the number of projects being combined. Provide a Divider, a Table of Contents, and the RFP sections (Parts 3-6). The header in each part must contain only the title of that Project and the corresponding eProjects Work Order Number for that project.

For RFPs in which Parts are shared, such as Part 2, Part 4, and Part 5, projects may be combined by simply using a Part 3 for each project, distinguished by the cover page and title, and inserted in Part 3; and a Part 6 for each project, distinguished by the title, and inserted in Part 6. In this case, parts A, B, and C dividers may not be required. Reflect the layout in the overall Table of Contents.

8-6.7.3 DB and DBB Hybrid.

For contracts where a DB RFP is combined with a DBB project, provide one project, complete, in Part A, and the other project, complete, in Part B; do not combine the General Requirements (Division 01) of these two different types of projects. An example is provided in Figure 8-2.

Figure 8-2 Sample Combined DB and DBB Project

PART A: GATE 5 SECURITY IMPROVEMENTS, NSA, NORFOLK, VA (WON 222088)	
DIVISION 01 - GENERAL REQUIREMENTS	
01 11 00	SUMMARY OF WORK
01 14 00	WORK RESTRICTIONS
01 20 00	PRICE AND PAYMENT PROCEDURES
01 30 00	ADMINISTRATIVE REQUIREMENTS
01 32 17.00 20	COST-LOADED NETWORK ANALYSIS SCHEDULES (NAS)
01 33 00	SUBMITTAL PROCEDURES
01 33 29	SUSTAINABILITY REQUIREMENTS AND REPORTING
01 35 26	GOVERNMENTAL SAFETY REQUIREMENTS
01 45 00	QUALITY CONTROL
01 50 00	TEMPORARY CONSTRUCTION FACILITIES AND CONTROLS
01 57 19	TEMPORARY ENVIRONMENTAL CONTROLS
01 57 19.01 20	SUPPLEMENTAL TEMPORARY ENVIRONMENTAL CONTROLS FOR GATE 5
01 57 19.02 20	SUPPLEMENTAL TEMPORARY ENVIRONMENTAL CONTROLS FOR GATE 10
01 58 00	PROJECT IDENTIFICATION
01 78 00	CLOSEOUT SUBMITTALS
01 78 23	OPERATION AND MAINTENANCE DATA
DIVISION 02 - SITE WORK	
02 41 00	[DEMOLITION][AND][DECONSTRUCTION]
DIVISION 26 - ELECTRICAL	
26 08 00	APPARATUS INSPECTION AND TESTING
26 32 15.00	ENGINE-GENERATOR SET STATIONARY 15-2500 KW, WITH AUXILIARIES
DIVISION 31 - EARTHWORK	
31 00 00	EARTHWORK
DIVISION 34 - TRANSPORTATION	
34 71 13.19	CRASH RATED ACTIVE VEHICLE BARRIERS AND CONTROLS
--End of Part A --	
PART B: GATE 2 SECURITY IMPROVEMENTS, NSA NORFOLK, VA (WON 352025)	
PART 1 - CONTRACT DOCUMENTS (Included under separate attachment)	
PART 2 - CONTRACT REQUIREMENTS	
PART 3 - PROJECT PROGRAM	
PART 4 - PERFORMANCE TECHNICAL SPECIFICATIONS (PTS)	
PART 5 - PRESCRIPTIVE TECHNICAL SPECIFICATIONS	
PART 6 - ATTACHMENTS	
-- End of Part B --	

8-6.7.4 Coversheet.

Provide one overall coversheet for signature. The coversheet must contain each of the eProjects Work Order Numbers. Contact the Government for which Work Order Number to use first as the primary. Also include project titles and if different Designers of Record prepared the RFP or specification, the information of each DOR firm or agency to be included. Be careful not to change the location of the electronic signature portlets when adding information to the coversheet.

8-6.7.5 List of Drawings.

Provide UFGS 00 01 15 listing drawings in the entire package. Group drawing lists by Project.

8-6.7.6 Table of Contents.

Provide a single, overall Table of Contents, listing each Part and the sections or documents in each Part. Note that SpecsIntact uses Courier New (10 pt) as the default font. Use this font to generate the Table of Contents and other documents in Word. A sample Table of Contents is provided in Figure 8-1 and Figure 8-2.

8-6.7.7 Submittal Registers.

Provide submittal registers for each Part at the end of UFGS 01 33 00 (for DBB) or UFGS 01 33 00.05 20 (for DB). Separate the submittal register for each part with a Divider; for example, bookmark "Part A: Submittal Register" (for Division 01 only), "Part B: Submittal Register," and "Part C Submittal Register," within the PDF package.

CHAPTER 9 DELIVERABLE: COST ESTIMATES

9-1 GENERAL REQUIREMENTS.

Provide cost estimates at each submittal in accordance with the applicable provisions of UFC 3-701-01, UFC 3-730-01, and UFC 3-740-05 unless specifically indicated otherwise in this chapter or in the contract documents. Cost estimates include budgetary estimates, current working estimates (CWE), independent government estimates (IGE), and independent cost estimates (ICE).

Provide cost and schedule risk analysis (CSRA), value engineering study (VES) and independent cost estimate (ICE) when required by the scope of services. Provide construction schedules in support of the cost estimate.

9-2 COST ESTIMATE CLASS STANDARDS.

Cost estimate classifications based on the maturity of the project definition deliverables is provided in Appendix B, Table B-1.

Table 9-1 indicates the appropriate AACE RP 56R-08 cost estimate class with the commensurate project phase.

Table 9-1 Cost Estimate Classification by Project Phase

Project Phase	Estimate Class
Final Design; Pre-Final Design	2,1
Design Development (35% - 50%)	3,2
DB RFP - Final	3
DB RFP - Draft	4,3
Budgetary; Preliminary Design (MILCON Checklist– see Paragraph 13-5 /1/); Schematic Design; Studies	4,3
Planning; Installation Level DD1391; Rough order of magnitude (ROM), comparison or screening; square foot (square meter)	5

9-3 COST ESTIMATE DEVELOPMENT REQUIREMENTS.

Base the cost estimate on the defined process as described in UFC 3-740-05. Unless otherwise directed, prepare cost estimates using latest MII software (Micro Computer Aided Cost Estimating System). Update cost estimate to the latest Cost Book and regional equipment library.

When the level of design does not support a quantity takeoff, the PACES software (Parametric Cost Estimating System) may be used and is to be exported to MII. The export is to be transferred into the appropriate NAVFAC MII template and updated to requirements in this chapter.

NAVFAC MII templates are provided on the WBDG website: <https://www.wbdg.org/navy/ceq>. Unless otherwise directed, use the latest version of these templates at the initiation of the cost estimate.

9-3.1 Level of Detail.

The level of detail for each cost estimate must be commensurate with the project phase. The detailed cost items are to appear at the appropriate locations and levels in the work breakdown structure (WBS). See Table 9-2. Each of the folders in the NAVFAC template includes notes indicating the unit of measure (UOM) to be used for that folder in accordance with UNIFORMAT II. Update the quantity at the folder level and use the indicated UOM. Segregate MILCON costs from Non-MILCON costs. Develop the price schedule line items in the cost estimate by maintaining the WBS for each line item.

\\1\

9-3.2 Labor Costs

Obtain current local pricing for labor rates at the time the cost estimate is developed.

9-3.3 Local Pricing for Projects OCONUS

Host nation consultant to provide current local pricing for major cost items and labor rates. This information is to be included as part of the backup documentation.

/1/

Table 9-2 MII Template Project Items Crosswalk

Source	MII Folder Levels	MII Folder Level Title	Sample Level Description	UNIFORMAT II		Use
				Levels	Values	
Template	0	Project	<i>Project Name</i>	N/A	N/A	Mandatory
Template	1	Project Phase ¹	<i>Base Bid</i>	N/A	N/A	Mandatory
Template	2	Facility Type ²	<i>Primary Facilities</i>	N/A	N/A	Mandatory
Template	3	Project Element ³	<i>Primary Facility</i> ^{1,4,5}	N/A	N/A	Mandatory
Template	4	Major Group Element	<i>Shell</i>	1	B ⁶	Mandatory
Template	5	Group Element (System)	<i>Superstructure</i>	2	B10 ⁶	Mandatory
Template	6	Individual Element (Subsystem)	<i>Floor Construction</i>	3	B1010 ⁶	Mandatory
Template	7	Sub-Element (Assembly)	<i>Floor Decks and Slabs</i>	4	B101003 ⁶	Mandatory
User	8	Sub-Assembly or Unit Price	<i>Floor Slabs</i>	N/A	N/A	Optional
User	9	Unit Price Line Items	<i>Detail Items</i>	N/A	N/A	Optional

Notes:

1. Project Phase is associated with large projects, such as Phase 1 of 4.
2. Facility Type values are either Primary, Supporting, or Other.
3. For Primary Facilities, include Cat Code as Source Tag.
4. For Primary Facilities Title use Cat Code Description
5. Include number of stories above and below grade in the Primary Facilities Title.
6. These UNIFORMAT II values are used as MII Source Tags at the corresponding MII Folder Levels.

9-3.4 Escalation.

Use the NAVFAC Building Cost Index (BCI) for escalation, unless supporting market analysis dictates otherwise. Update the cost estimate at each submittal to reflect the current escalation. The NAVFAC BCI can be found on the WBDG website (<https://www.wbdg.org/navy/ceg>).

Include the escalation variance as a consideration in the sensitivity analysis and CSRA.

9-3.5 Job Office Overhead (JOOH).

Inform the duration of JOOH costs from the construction schedule. It is permitted to define the rate of JOOH as a percentage in earlier phases of design up to a Class 4 cost estimate. Itemized JOOH is required on Class 1, 2 and 3 cost estimates.

9-3.6 Markup Requirements.

The markups defined below are to be addressed in the cost estimate.

9-3.6.1 Direct Cost Markups.

- Productivity.
- Overtime.
- Sales Tax.
- Cost Data Escalation – Used to escalate direct material, labor and equipment costs from the cost data source date(s) to the date of the cost estimate.
- Design Contingency – Global application of this markup is allowed for an early design level, by pre-final submittal it is expected the markup be applied at a system level. The cost engineer owns this markup. Design contingency may also be addressed by including allowances.

9-3.6.2 Contractor Markups.

The following contractor markups are to be addressed for prime and subcontractors.

- JOOH
- Home Office Overhead (HOOH)
- Profit
- Bond and Insurances
- Excise Tax
- DB Fee
- Competition Premium - Used to account for markets with low competition. Do not use if a CSRA is included in the project as it is expected that the level of competition will be considered as a risk factor in the model.

9-3.6.3 Owner Markups.

These markups must be applied in the following order within MII.

- Market Escalation: used to escalate the project from the date of the cost estimate to the mid-point of construction.

- Risk Contingency: If a CSRA was developed as part of the scope of the project then the resulting contingency is to be applied as an owner markup.

9-3.6.4 Construction Contingency.

Construction contingency is not included as a part of the cost estimate. This cost is accounted for outside of the cost estimate.

9-3.6.5 Supervision Inspection and Overhead (SIOH).

SIOH is not included as a part of the cost estimate. This cost is accounted for outside of the cost estimate.

9-3.7 Development of Specific Task.

Clearly identify specific tasks with unique source tags.

9-3.5.1 Cost Overrides and Modified Cost Task.

Clearly document in the cost estimate overrides or modifications to component of the cost item that originates from published data.

9-3.5.2 User Items.

Clearly document user items in the cost estimate.

9-3.5.3 Assemblies.

Clearly document assemblies used in the cost estimate.

9-4 SENSITIVITY ANALYSIS.

11 Perform a sensitivity analysis in accordance with UFC 3-740-05 for NAVFAC cost estimates. The results of the sensitivity analysis are used to inform the cost estimate, 11/ CSRA and the ICE. For PEO II projects, utilize the value from the upper end of the uncertainty range in the base cost estimate and do not model the variation of the uncertainty item in the CSRA. Update the sensitivity analysis at each cost estimate submittal.

9-5 COST AND SCHEDULE RISK ANALYSIS (CSRA).

Perform the Cost and Schedule Risk Analysis (CSRA) in accordance with UFC 3-740-05 on projects greater than \$20 million unless otherwise directed by NAVFAC Cost TDC. The Tri-Service CSRA template is located under Related Materials on the WBDG website for UFC 3-740-05. Develop CSRA models using the Crystal Ball add-in to MS Excel unless otherwise approved by the NAVFAC Cost TDC. Base the default risk contingency on an 85% Confidence Level unless otherwise directed or specifically

required by governing policy or directive. Update the CSRA at each cost estimate submittal.

9-5.1 Budgeting CSRA.

The budgetary estimate is to consider each risk to inform the final Program Amount. Consider pre-award and post-award risk as well as uncertainty items in the CSRA.

9-5.2 Design CSRA.

During the design phase, consider risk to predict the price of the project in market. Each modeled risk must have identified risk reduction measures that are updated at each submittal. Consider each risk that the contractor will take into account during bidding. Keep track of post-award risks in the risk register but do not model them.

9-5.3 Construction CSRA.

If required during the construction phase of the project, the CSRA is leveraged to develop both the total contingency value and when those contingency dollars will be needed (FY). The model is to be updated on a continual basis as directed by the NAVFAC PM to better inform the contingency position. Include post-award risks focused on items that could occur during construction. Utilize to the greatest extent possible, the schedule of prices, cost loaded schedule, and the contract unit prices for informing and quantifying the risks.

9-5.4 Schedule Risk.

If a schedule risk is modeled, always model the associated cost from schedule impact regardless of magnitude. The quantified value accounts the JOOH monthly rate as well as the cost of escalation incurred by the additional duration. Calculate the monthly cost of escalation by determining the total dollar value of escalation in the base estimate divided by the construction duration.

9-6 VALUE ENGINEERING STUDIES (VES).

When required, provide a VES in accordance with Appendix B3.

9-7 INDEPENDENT COST ESTIMATE (ICE).

When required, an ICE is developed in addition to the DOR's cost estimate. The ICE is prepared by a qualified, third-party cost estimator independent of the project stakeholders. It is prepared in accordance with cost criteria and includes sensitivity analysis as well as a construction schedule to support comparative evaluations. The ICE must be developed with the same design documents and use the same WBS used to generate the DOR's cost estimate. To restrict potential bias, information from the DOR's cost estimate must be withheld from the ICE estimator to the maximum extent practical. The Government may provide supplemental information to the ICE estimator

such as Charrette report, studies, and CSRA risk register. The ICE will be reviewed by the Government in the same manner as the DOR's estimate.

At the initiation of the ICE process (awarding an ICE contract), the Government cost engineer will schedule and hold a kickoff meeting for the ICE process to be attended by the DOR and the ICE estimator teams. During the development period, there will be bi-weekly meeting with the DOR and ICE estimator as scheduled by the Government cost engineer.

9-7.1 Reconciliation.

Reconciliation occurs at defined milestones and is a collaborative process between the Government, DOR, and ICE estimator. The Government cost engineer is responsible for leading the reconciliation process. This process will be repeated for each design submittal, except Final. The Government cost engineer will compare the ICE and DOR cost estimates in two steps. The first step of the analysis will focus on quantities and the cost estimates' sensitivity analyses. In this first step the Government cost engineer will summarize the results of the comparison in a report and forward it to the DOR and the ICE estimators for their review. The Government cost engineer will then schedule and facilitate a Quantity Reconciliation meeting to reconcile quantities and sensitivity analysis differences. The DOR and ICE cost estimates will be updated based on this meeting.

Using the DOR and ICE cost estimates updated from the first step, the Government cost engineer will compare the two estimates focusing on remaining differences in cost and schedule. In the second step of the analysis, the Government cost engineer will summarize the results in a comparison report. This report will be forwarded the DOR and the ICE estimators for their review. The Government estimator will then schedule and facilitate a Reconciliation Workshop to reconcile remaining cost and schedule differences.

9-7.2 Documentation.

The DOR retains the responsibility for the CWE developed for each design submittal. During the reconciliation workshop, the DOR will document discussions and inform their cost estimate at their discretion. The DOR's basis of estimate will be updated to document the key recommendations from the workshop as well as which recommendations were considered in the reconciled CWE. Recommendations that were not considered need to be documented with appropriate rationale for exclusion.

9-8 CONSTRUCTION SCHEDULE.

Provide a construction network analysis schedule (NAS) in support of the cost estimate and CSRA. \1\ Prepare construction schedules using Primavera P6 or Microsoft Project, unless otherwise approved by the NAVFAC Cost TDC. /1/ Use the duration, crew hours, and labor hours from the cost estimate to inform the construction schedule. In turn, the cost estimate must include itemized job overhead costs informed by the construction schedule. This construction schedule is part of the cost estimate supporting documentation and will not be shared with the Contractor. Update the construction schedule at each cost estimate submittal.

9-8.1 Construction Schedule Class Standards.

Construction schedule classifications based on the maturity of the project definition. Unless otherwise directed by the NAVFAC cost engineer, the construction schedule is to be roughly equivalent to a Class 3 schedule as defined in AACE Recommended Practice 27R-03.

9-8.2 Construction Schedule Development Requirements.

The schedule must incorporate the following best practices from GAO-16-89G.

1. Capture activities defined in the schedule WBS at a sufficient level of detail to accomplish the project's objectives.
2. Sequence activities in logic-driven predecessor-successor relationships, minimizing the use of lags and date constraints.
3. Establish durations for activities. These durations are to be informed by the cost estimate.
4. Verify that the schedule can be traced horizontally and vertically.
5. Identify and validate the critical path.
6. Identify a reasonable total float.
7. Incorporate the schedule information in the CSRA.

The schedule must also incorporate the following.

1. Environmental requirements (i.e., permits, fish windows, or SHPO.)
2. Impact of known installation activities upon the construction contractor's operations.
3. Seasonal weather considerations including impact on the site soils.
4. Durations for submission and approval of administrative submittals.
5. Durations for material lead time and installation.
6. Interface of work trades within the project.
7. Productivity losses triggered by lack of lay-down/storage space.

The level of activity detail within the construction schedule is to be in accordance with Table 9-3.

Table 9-3 \1\ /1/Activity Detail by Schedule Class

Class	Activity with Duration Greater than
5	12 Weeks
4	10 Weeks
3	4 Weeks
2	2 Weeks
1	1 Week

9-8.3 Cost-Loaded Construction Schedule.

When directed, develop a cost-loaded construction schedule based on the values from the cost estimate. Assign cost respective to the construction activities. Activities assigned Government responsibility are to have zero cost. No contractor cost is to be assigned to an activity designated as a Government responsibility.

9-9 SUBMITTAL REQUIREMENTS.

Provide a cost estimate package in a separate submittal to the PM/DM only. In a single PDF combine the basis of estimate (BOE), MII cost estimate report, CSRA report, sensitivity analysis, VES, basis of schedule (BOS), \1\ construction schedule, and backup data for a complete report. /1/

9-9.1 BOE.

For each submittal, provide a narrative BOE. In addition to the requirements defined in the UFC 3-740-05, the BOE must include the following information:

- Provide a complete schedule of cost estimate submittals.
- Establish and maintain a table summarizing the cost development at each submittal in accordance with the WBS and using ASTM E1804 as guidance. The initial table entry is to be the budget or DD1391 estimated costs. Subsequent entries are to be added during the design development. Evaluate and describe the causes of variances exceeding 10% of UNIFORMAT II Level 1 and Level 2 cost elements, sub-totals, or

totals between the current cost estimate submittal and the previously submitted cost estimate.

- State the estimating methodology used to develop the cost estimate.
- Provide a narrative of the current construction market and expectation for changes through the planned construction period at the project location. This is to include availability of labor and materials and market drivers. Describe how the cost estimate accounts for the current construction market, including markups applied.
- Include the assumed minimum number of bidders.
- Include a summary of work self-performed by the prime contractor and work to be performed by subcontractors.
- Describe the development of the applied direct markups and include details backed up by industry data and/or calculations justifying percentages used for direct markups. Do not make broad statements such as “based on historical data.”
- Describe the development of the contractor markups and include details backed up by industry data and/or calculations justifying percentages used for contractor markups. Do not make broad statements such as “based on historical data.”
- Describe the development of the risk contingency markup.
- Describe the development of the market escalation markup.
- Describe the development design contingencies incorporated into the cost estimate and provide a defensible position.
- Describe the software tools and associated databases used in the development of the cost estimate.
- Describe the sources of cost data for material, labor and equipment.
- Describe the reasonableness of the proposed construction schedule to meet the contract award within the budget year or meeting the defined Initial Operational Capability (IOC) date.
- Describe the results from the sensitivity analysis identifying key cost drivers impacting the total construction cost by 5% or greater. The results of this analysis are to be captured in a table identifying the parameters or assumptions and the range of variation assumed for each key cost driver.

9-9.2 MII Cost Estimate Report and Native File.

Prepare and submit cost estimate reports using NAVFAC MII Standard Report Templates (<https://www.wbdg.org/navy/ceg>). Provide the native MII (.mlp) file.

9-9.3 Sensitivity Analysis.

Provide a report describing the process and documenting the results. The report is to include a graphical summary of the results to illustrate the relative impact of each factor identified in the analysis.

9-9.4 CSRA Report and Model.

\\ Provide /1/ the native Excel macro-enabled CSRA model file and CSRA Report. The CSRA Report Template is available under Related Materials on the WBDG website for UFC 3-740-05.

9-9.5 VES Report.

If a VES is required, provide a copy of the latest version of the VES report.

9-9.6 Basis of Schedule.

Provide a schedule narrative to accompany the schedule. The scope of the schedule narrative will vary with project and contract complexity, but include at a minimum:

- Status of key milestone dates, including the project finish date.
- Explanations for key dates.
- Changes in network logic, including lags, date constraints.
- Relationship logic, and their effect on the schedule.
- Description of the critical paths, near-critical paths, and longest paths along with a comparison to the previous period's paths.
- Description of significant scheduling software options that have changed between update periods, such as the criticality threshold for total float and progress override versus retained logic and whether or not resource assignments progress with duration.

9-9.7 Construction Schedule Native \\ File and /1/ Report.

Provide the native construction schedule file (Primavera P6 or Microsoft Project, \\ unless otherwise approved by the NAVFAC cost TDC) and a PDF schedule report. The report is to include fields for activity ID, activity name, the WBS of the activity parent folder, activity original duration, activity start, activity finish, predecessors, and successors. /1/

This Page Intentionally Left Blank

CHAPTER 10 DELIVERABLE: CONTRACTING REQUIREMENTS

10-1 GENERAL REQUIREMENTS.

The Contract Specialist incorporates line items from the information provided in the Project Information Form (PIF) and Price Schedule. Provide the PIF and Price Schedule in Microsoft Word or Adobe PDF format to the Government Project Manager who will provide it to the Contracting Specialist.

10-2 PROJECT INFORMATION FORM (PIF).

Prepare and provide a Project Information Form (PIF). The PIF communicates to the Contract Specialist which contract clauses to include in the solicitation. The Government Project Manager provides the PIF to the Contracting Specialist to prepare the contract clauses for the solicitation. A downloadable version of the PIF is available on the WBDG (<https://www.wbdg.org/navy/project-information-form-specifications-cover-sheet/project-info-form>).

10-3 SELECTION OF LINE ITEMS.

The Base Price line item must provide a complete and usable facility (primary facility, supporting facilities, and design for DB projects). Option items and additive items must be able to be logically separated from the project without rendering the facility unusable. Intention is for the Base Price, together with the line items, to provide the maximum, usable facility within the funds available. Do not use Additive and Option items in the same contract; use one or the other. Additive items are only allowed for sealed bids; do not use unless authorized by Contracting Officer.

Use multiple line items for cost breakdown of facilities and site, and unit prices as established in the price schedule template. Use multiple line items for multiple funding sources (such as when combining one or more projects into one contract package), and option or additive line items. Provide separate SUB-CLINs for (1) Each facility (as indicated by the Category Code), (2) The total project supporting facility (utility) cost (outside the 5 foot (1.5 m) line), and (3) Design Fee (if a DB project). The number of items and the estimated cost per item depends upon the nature of the project. Provide no more than four contract line items (base item, plus three), unless specifically approved by the Contracting Officer. Each estimated option or additive item should tend to approximate 2% to 10% of the estimated base item.

A downloadable version of the Price Schedule is available on the WBDG (<https://www.wbdg.org/navy/project-information-form-specifications-cover-sheet/price-schedule>).

10-4 OPTIONS AND ADDITIVES.

Options and Additives can change up to award of the contract. Do not indicate line items on the drawings, or reference anywhere in the specifications, unless approved by the Government, who may allow only if a description of the line item in the price schedule does not adequately describe the work.

Do not use the term “alternate” to represent line items. Do not use terms, such as “base item” to indicate items in the primary contract line item.

10-5 OPTION ITEMS.

Option items provide a means to separate the funding sources or to obtain and hold competitive prices for future award of items of work. Use option items when different funding sources are used (examples: Furniture, Fixture, and Equipment (FF&E), Electronic Security System (ESS) equipment, Audio Visual System (A/V) Equipment), or when funding is not available to cover certain portions of the work at the time of proposal opening, but there exists a high probability of attaining the funding in the near future. Typically, the price for the option item(s) is added to the base item price to determine the low offer. Options need not be listed in a particular order. They are executed individually at the Government’s discretion. A time limit is given in the contract documents for the Government’s right to execute each option. Use of options in construction contracts must be approved by the Contracting Officer prior to advertisement.

10-6 ADDITIVE ITEMS.

Since additive line items are only allowed in sealed bid, do not use these unless authorized by the Contracting Officer. If used, arrange additive items such that the most essential portion of the work is added first. Arrange succeeding items in decreasing importance. During evaluation of the offers, additive items are added to the base item in the order listed. As each additive item is added, a new bid price is computed and compared to the available funds. As additive items are determined to be within the funds available, they are added to the Offeror’s bid price. If they are not within the funds available, they are skipped. Each additive item must be independent of the others.

10-7 DEDUCTIVE ITEMS.

Do not use deductive items. The Base Price line item must contain the minimum requirements of the contract. Using deductive items implies that the project is designed above the minimum requirements. Use Options instead.

CHAPTER 11 DELIVERABLE: DB REQUEST FOR PROPOSAL (RFP)

11-1 GENERAL REQUIREMENTS.

Requirements for preparation of RFP are also provided in Chapter 12.

11-2 DB REQUEST FOR PROPOSAL INTRODUCTION.

NAVFAC Design-Build (DB) RFPs are developed by organizing project requirements into the NAVFAC DB Six Part Format to procure facilities for our Navy Customers and Users. Requirements included in the RFP are driven by the need to control the design and the construction of the facility. Because the Contractor is designing and constructing the facility, design issues are just as important as construction issues and must be given equal consideration. The RFP information may be gathered from many sources such as:

- DD Form 1391 Documentation
- Funding Documents
- Site conditions and Restraints
- User Requirements
- Local and Regional Requirements
- Applicable Standards and Codes
- Applicable NAVFAC and DoD Criteria and Clauses
- Performance and Prescriptive Product, Material, and System Requirements

RFPs are a combination of performance and prescriptive requirements, but give preference to performance requirements for DB. However, many times prescriptive requirements are necessary to define a minimum acceptable solution or expected level of quality. Therefore, mold the type of information included in the RFP to meet the anticipated level of quality and needs of the User. Create performance and prescriptive requirements that comply with the following characteristics of each.

- Performance requirements state the function, desired results, and durability to control the Contractor's design and selection of products, materials, and systems.
- Prescriptive requirements define the products, materials, and system or their characteristics to control the facility function, performance, and quality.

11-3 DB REQUEST FOR PROPOSAL WEBSITE, FORMAT, AND DOCUMENTS.

Guidance on preparing the RFP for DB projects and DB Template documents are available on the NAVFAC DB Master website (<https://www.wbdg.org/navy/ndbm>). This site is intended to (1) familiarize those new to the NAVFAC DB process with the RFP format and typical RFP specification sections and (2) allow those preparing a DB RFP to download the current and archived electronic documents. The DB RFP website is organized using links to major components of the DB RFP, including:

- Overview and Training - NAVFAC RFP Format, UniFormat® Information Structures, and NAVFAC Technical Contacts responsible for document maintenance.
- Design Guidance.
- Standard Template – This is the foundation template that can be used on projects. The Standard Template is designed to cover most of the building types routinely designed and built by NAVFAC. Industrial and specialized facilities are examples of building types that require additional information to be added to the Standard Template to cover the design, materials, and equipment that are unique to these building types.
- Model RFP Templates - The Model RFP Templates use the Standard Template as its foundation. Each Model Template modifies the Standard Template to suit a particular building type. These Models are an advanced starting point toward creating an RFP, however they do require coordination with User and facility requirements to properly define the final RFP. The building type templates in the DB Master website are:
 - o Armory
 - o Child Development Centers
 - o Dining Facility
 - o Entry Control Facility
 - o Fire Station
 - o Fitness Center
 - o Hangar
 - o Magazine
 - o Marine Corp BEQ
 - o Market Style BEQ

- Small Project Template (SPT): The SPT is a scaled down version of the Standard Template to be used on projects of low-complexity and a limited number of construction trades. SPT projects utilize routine designs with limited plans and specifications and fit within monetary thresholds.
 - o The table “Small Project Design-Guidance” is located with the SPT on the WBDG (<https://www.wbdg.org/navy/ndbm/small-project-template>) to provide guidance in the application of the SPT.

11-3.1 RFP Format.

The RFP must include the six RFP Parts indicated below unless they are not applicable to the project. The typical facility project will have information in every RFP Part, with the possible exception of RFP Part Five, “Prescriptive Specifications.” Typically, Part One is not prepared by the RFP developer, but is provided by the NAVFAC Contracting office after RFP Parts Two through Six have been completed by the RFP developer. The RFP developer is required to provide certain information such as the Project Information Form (PIF) for the NAVFAC Contracting office to properly prepare the RFP Part One. Verify with the NAVFAC Facility Engineering Command, what provisions are necessary to allow for the RFP Part One to be integrated into the RFP.

The DB Templates utilize different types of information in different Parts of the RFP. Therefore, there are different information structures employed to organize the information in the different RFP Parts. The following list indicates the type of information and information structures are used in the RFP Parts:

- **Part One** includes the Proposal Form and Documents and specifies the contractual requirements.
 - o This Part uses the Standard Procurement System documents that are organized using the CSI MasterFormat®.
- **Part Two** contains the General Requirements Specification Sections – some only available at the DB website.
 - o This Part uses specification sections organized using CSI MasterFormat®.
- **Part Three** contains the Project Program for the project.
 - o This Part predominately uses a paragraph format; Chapter Six of Part 3, the Engineering Systems Requirements uses UniFormat®.
- **Part Four** contains the Performance Technical Specifications.
 - o This Part uses UniFormat®.

- **Part Five** contains Prescriptive Specifications required for the DB RFP.
 - o This Part uses CSI MasterFormat®.
- **Part Six** includes attachments to define existing conditions and design requirements (such as Boring Logs, reference drawings).
 - o This Part is a combination of various attachments that have no predominate format.

11-3.2 Recommend Change to DB Documents.

Submit a Contract Change Request (CCR) on the DB website to recommend a change to the DB documents.

11-4 DB REQUEST FOR PROPOSAL DOCUMENT PREPARATION.

The DB documents are updated and changed regularly. Because the DB documents change regularly, it is necessary to use the updated documents when creating an RFP. Download the most current versions available on the DB website. Each DB Template and Model RFP Templates has a DOWNLOAD feature. Download individual documents or documents organized into RFP Parts.

11-4.1 Combining Multiple RFPs into One Bid Package.

Refer to Chapter 8 for guidance, when multiple RFPs are combined into one solicitation package.

11-4.2 Project Information Form (PIF).

Provide and complete the PIF for Prefinal and Final submittals. Refer to Chapter 8 for further PIF requirements.

11-5 RFP ELECTRONIC DELIVERABLES.

Provide RFP electronically in accordance with Chapter 12. Organize the RFP into one or two PDF files, with order shown in the following Table of Contents. Bookmark each item below, and the additional items indicated.

1. RFP Coversheet
 2. RFP PART 1 Divider (when directed by the Command)
 3. Overall, RFP Table of Contents (Parts 2-6)
 4. RFP PART 2 Divider
- \\ / /
- a. RFP Part 2 Specification Sections (bookmark first page of each section)

5. RFP PART 3 Divider
 - a. RFP Part 3 Project Program Coversheet
\\ / /
 - b. RFP Part 3 Project Program
 - c. Each Chapter of RFP Part 3 (bookmark first page)
 - d. Each ESR in Chapter 6 (bookmark first page)
6. RFP PART 4 Divider
\\ / /
 - a. RFP Part 4 Performance Technical Specifications (bookmark first page of each PTS)
7. RFP PART 5 Divider (if prescriptive specifications are included in the RFP)
\\ / /
 - a. RFP Part 5 Specification Sections (bookmark first page of each section)
8. RFP PART 6 Divider
\\ / /
 - (1) Attachments (bookmark first page of each attachment)

11-6 DB DESIGN SUBMITTALS.

Provide design submittals electronically in accordance with Chapter 12. Include information and organize DB design submittals in accordance with this FC and UFGS 01 33 10.05 20.

11-7 DESIGN AND CONSTRUCTION SUBMITTAL REQUIREMENTS.

Because the DB projects require design and construction submittals, the submittals are more complex than DBB. The DB process utilizes the RFP and the UFCs to define design submittals and the RFP and the UFGS to define construction submittals.

11-7.1 Locations of DB Submittal Requirements.

Because the DB submittals are spread into different documents, the preparers of DB submittals are required to refer to multiple locations to obtain the complete submittal requirement. The design and construction requirements are found in the six major locations designated in the following table:

Table 11-1 Design and Construction Submittal Summary

DB DESIGN and CONSTRUCTION SUBMITTAL SUMMARY			
NO	DOCUMENT	LOCATION	SUBMITTAL REQUIREMENT
1	RFP Part Two UFGS Specs	NAVFAC DB RFP Website	
	A, Most RFP Part Two	RFP Part Two	Lists <i>Project Specific</i> Administrative Submittals for Government Approval
	B. UFGS 01 33 00.05 20 <i>Construction Submittal Procedures</i>	RFP Part Two	Lists <i>Project Specific</i> Government Reserved Construction Submittals for Approval or Surveillance
	C. UFGS 01 33 10.05 20 <i>Design Submittal Procedures</i>	RFP Part Two	Lists <i>Project Specific</i> Design Submittals
2.	Engineering System Requirements (ESR)	RFP Part Three	Lists <i>Project Specific</i> Design Requirements
3.	Performance Technical Specification (PTS)	RFP Part Four	Lists <i>PTS Specific</i> Critical Construction Submittals for DOR approval and Construction Submittal requirements
4.	Unified Facility Guide Specifications (UFGS)	Whole Building Design Guide Website	Edited UFGS specification required by RFP Part Two for Contractor's Design Submittal and Compliance to UFGS technical requirements
5.	FC 01-300-09N Navy and Marine Corps <i>Design Procedures</i>	Whole Building Design Guide Website	Lists <i>Discipline Specific</i> Design Submittals for NAVFAC to supplement Core UFCs
6.	Discipline Specific UFCs (Arch, Struct, Civil, Geotech, Mech, Elect, Fire Protection, Force Protection Anti-Terrorism)	Whole Building Design Guide Website, some temporarily on DB Website in Design Guidance web page	Lists <i>Discipline Specific</i> Design Requirements and Explanation of FC 01-300-09N listed design submittals

11-7.2 Government Approval and Surveillance of DB Submittals.

The RFP DB submittals are organized to allow the RFP editor the flexibility to evaluate the project needs, determine the availability of Government resources to review submittals, and modify the submittal approval requirements to suite the project. The following Government approvals are built into the RFP Part Two DB Templates but may need input from the RFP editor to tailor the submittal to the project:

- a. RFP Part Two, UFGS 01 33 00.05 20, Submittals Reserved for Government Approval - RFP Part Two UFGS section submittals denoted with a "G" submittal action code.
- b. RFP Part Two, UFGS 01 33 10.05 20, Government Approving Authority – Government approves each design submittal.
- c. RFP Part Two, UFGS 01 33 10.05 20, Exception to Contractor Construction Actions – Identifies certain Government design submittals approvals that have to be accomplished before construction related to that design submittal can begin.

- d. RFP Part Two, UFGS 01 33 10.05 20, Design Documents, and UFGS 01 33 00.05 20, Contractor Reviewing, Certifying, Approving Authority - Government identified construction submittals required to be incorporated in the design submittals. DOR approval of identified construction submittals precedes Government approval of associated design submittals.
- e. RFP Part Two, UFGS 01 33 00.05 20, Submittals Reserved for Government Approval - Construction submittals reserved for Government approval. The approval of these identified construction submittals prevents the contractor from beginning construction on that portion of the work until Government approval is obtained.

11-7.2.1 Surveillance Submittals.

The Government requires the contractor's DOR to approve most of the construction submittals; however, the RFP identifies certain construction submittals for Government surveillance. Government surveillance does not prevent the contractor from proceeding with construction but allows the Government a chance to confirm the submittal approvals of the DOR. Surveillance of construction submittals are built into the DB Template at the following location:

RFP Part Two, UFGS 01 33 00.05 20, Submittals Reserved for Government Surveillance - Construction Submittals Reserved for Government surveillance.

11-7.2.2 Critical Path Submittals.

Contractor submittals in DB may be designated as Critical Path Submittals, as further described in UFGS 01 33 10.05 20 of the RFP. In this situation, the submittal may only contain the design of one or a few disciplines, for example, civil and structural. Follow the submittal requirements as applicable for the disciplines pertaining to that critical path submittal. Ensure that work is included and coordinated with the other disciplines that are affected by that critical path work; for example, electrical and mechanical site work is included and shown on the civil site work critical path submittal, and provisions are made for the utility service entrances through foundation and for major pieces of equipment for the foundation work critical path submittal.

This Page Intentionally Left Blank

CHAPTER 12 ELECTRONIC DESIGN DELIVERABLES (EDD) FORMAT

12-1 SUMMARY.

This Chapter sets the policy for NAVFAC compliance with DoD and Navy policy for paperless contracting systems. The DoD requires implementation of electronic bid solicitation at NAVFAC components for construction projects. These EDD requirements provide NAVFAC specific format guidance. Regardless of contracting method, projects must follow these EDD requirements. DB RFP submittals follow the requirements for the phase of design in the following paragraphs.

12-2 EDD.

The following electronic deliverables are required for projects:

- Contract Drawing source files
- Contract Drawings
- Input and output source files for structural calculations
- Specifications or RFP
- RFP source files
- Specification source files
- Calculations
- Cost Estimate
- Reports, Surveys and Studies
- Basis of Design
- eOMSI Facility Data Workbook (FDW)
- Project Execution Plan (PxP)*
- Design Model*
- Record Model*
- Record Drawings source files
- Record Drawings
- Shop Drawings/transmittals
- Architectural Color Boards (photos) (where applicable)
- Submittal Register
- Other (such as Photos or Project background/support files)
- Price Schedule (when required)
- High Performance and Sustainable Building Checklist (where applicable)
- TPC Checklist (where applicable)

* - Applies to BIM Projects Only

12-3 EDD FORMAT REQUIREMENTS.

12-3.1 Specifications.

Develop Project Specifications in accordance with the requirements of this FC and UFC 1-300-02, using SpecsIntact software. Organization of PDF for Specifications is described in Chapter 8. Organization of PDF for RFP is described in Chapter 11.

12-3.1.1 Specification Source Files.

From the SpecsIntact Job File, provide the following source files: “Pulldata” and “Submittal Register.” “Printdata” does not have to be provided.

12-3.1.2 DB RFP Part 2 Source Files.

Develop RFP and Part 2 specifications in accordance with Chapter 11 of this FC.

If a program other than SpecsIntact is allowed to be used, original source data must be provided as follows:

- The native authoring application file format.
- A PDF format print of the original authoring data. No scans, copied images, or third party reproductions of paper prints will be accepted.

12-3.2 Electronic Operation and Maintenance Support Information (eOMSI) Facility Data Workbook (FDW).

When required by the contract, provide the Excel workbook, which contains the Model & Facility Data Matrix tab (used to select Mastersystems, Systems, and Subsystems included in the design). Use the original eOMSI FDW source file, as referenced in Appendix E, for each project.

Complete the eOMSI FDW in accordance with the Instructions tab of the eOMSI FDW.

12-3.3 Drawings.

12-3.3.1 Drawing Definitions.

12-3.3.2 Drawing Source Files.

Produce source drawings using vector-based Computer Aided Design (CAD) software. Provide source drawing files in native format meeting the following requirements.

12-3.3.2.1 Contract Drawing Source Files.

Contract drawing source files are the native CAD files (such as plans, elevations, sections, details) created by the DOR for the project. The Contract Drawing Source Files are not the legal record of the project Design.

12-3.3.2.2 Contract Drawings.

The PDF files created from the Contract Drawing Source Files represent the scope of the projects. The Contract Drawings are the legal record of project Design which are awarded to the construction contractor (KTR) which includes amendments.

12-3.3.2.3 As-Built Drawings.

The hard copy prints of the Contract Drawings marked up by the KTR (in accordance with the project specifications) to represent approved changes to the Contract Drawings.

12-3.3.2.4 Record Drawing Source Files.

The Contract Drawing Source Files edited by the KTR or DOR (depending on contract requirements) to reflect the changes shown on the approved As-Built Drawings. Prepare Record Drawing Source Files as described in this Chapter, Record Drawing Preparation. Record Drawing Source Files are not a legal record of the Project.

12-3.3.2.5 Record Drawings.

The PDF files created from the Record Drawing Source Files that represent the final installed condition of the project. Prepare the project Record Drawings as described in this Chapter, Record Drawing Preparation. The Record Drawings are the legal record of the completed project.

12-3.3.3 Drawing Progression.

Naming conventions and procedures as drawing progresses through design, construction, and post-construction are indicated in Figures 12-1 and 12-2.

Figure 12-1 Drawing Progression Chart DBB

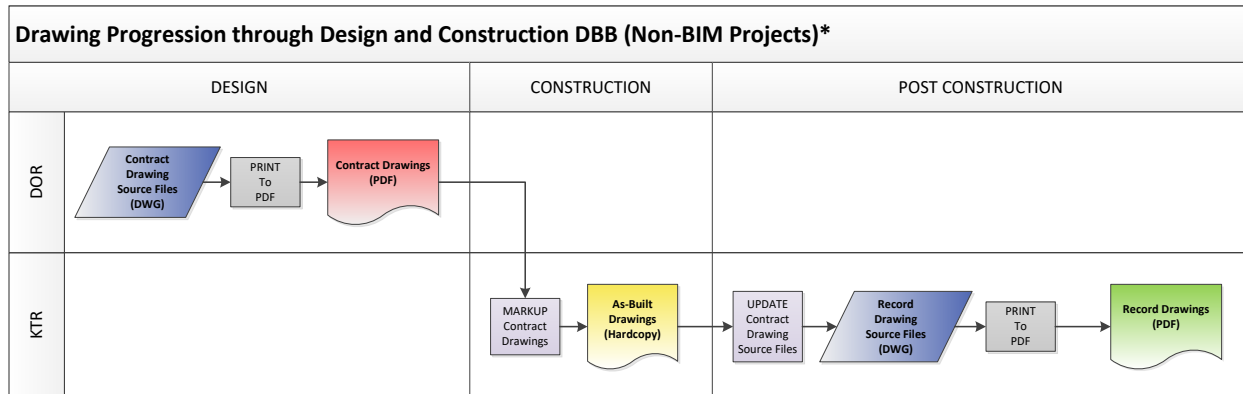

*This example reflects the KTR producing the record drawings.



Print the source drawings to PDF files. The PDF becomes the legal record.



KTR marks up the PDF Contract Drawings to reflect approved changes to the Contract.



KTR updates the Contract Drawing Source Files to reflect the changes shown on the As-Built Drawings.

Figure 12-2 Drawing Progression Chart DB

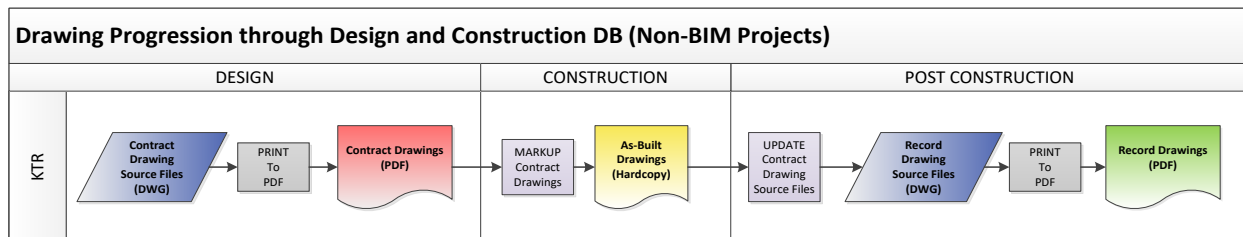

Print the source drawings to PDF files. The PDF becomes the legal record.



KTR marks up the PDF Contract Drawings to reflect approved changes to the Contract.



KTR updates the Contract Drawing Source Files to reflect the changes shown on the As-Built Drawings.

12-3.3.4 CAD Standards.

CAD standards order of precedence are the requirements of this Chapter, then the latest versions of the DoD A/E/C CAD Standard and A/E/C Graphics Standard (A/E/C) then the National CAD Standard (NCS). In cases where the DoD A/E/C standards version changes after a project has commenced, the project PM must be consulted prior to adoption and integration of the newer standard into the drawing source files.

12-3.3.4.1 NAVFAC Standard Drawing Format.

Sheet drawings must use the NAVFAC standard title block (border sheet). Provide sheet drawings in ANSI D (22 x 34 inches) size format for projects using imperial units. Provide sheet drawings in ISO A1 (594 x 841 mm) for projects using metric units (ANSI D is assumed in other parts of this FC but modify and scale as appropriate if ISO A1 is used). See 12-3.7 NAVFAC Supported EDD Standard Components for border sheet templates and pen configuration table.

AutoCAD Source drawings must contain only one plotted sheet. Drawing source files which contain more than one sheet will be rejected with the following exceptions:

- Civil Sheet Files and other site plans (such as site utilities - electrical and telecommunications) in which the entirety of the project site cannot be legibly shown on a single sheet.
- Plan Sheet Files which the entirety of the project plan cannot be legibly shown on a single sheet at 1/8" = 1'- 0" (1 = 100) scale.

In both cases consult with the project PM prior to developing sheet files to ensure concurrence.

12-3.3.4.2 Plotting Guidelines.

AutoCAD pen weights and colors must be in accordance with the NAVFAC pen table. NAVFAC has developed a comprehensive pen table that utilizes the NCS 255-pen table as a basis but has added thinner lines and grayscale pens. Color numbers are assigned to "black" or "halftone" except where the pen table provides for color in other plotting applications. In the NAVFAC Revit templates, lineweights of model elements are scaled annotatively by default. Annotation lineweights have been adjusted to match the NAVFAC pen table for consistent plot results across disciplines. For BIM applications not using the Revit template or other BIM software, the plotted lineweights must match the NAVFAC pen table.

The NAVFAC Revit templates, the NAVFAC AutoCAD standard border, and the NAVFAC pen table references are provided on the WBDG (See paragraph 12-3.7 NAVFAC Supported EDD Standard Components). This pen table and corresponding line weights were established to be legible when printed at half-size (11 x 17 inches (279 x 431 mm)). Plotted files (hardcopy or PDF) must be monochrome unless color

plots are specifically requested, for example, 3D representation (isometrics, perspectives, photographs).

12-3.3.4.3 Text Font and Size.

Use standard and consistent text heights for a plotted full-size drawing throughout the project of 3/32 inch (2.4 mm) minimum, 1/8 inch (3 mm) preferred, for dimensions, notes, callouts, tables, schedules, and general typical text. Use 3/16 inch (5 mm) minimum for view title text, and 1 inch (25 mm) maximum for project titles on cover sheets. For existing features on plotted full-size civil drawings, a maximum oblique angle of 12 degrees is allowed. The text width factor must not be less than 0.8 for fonts in the body of the construction document. All fonts in the border, gutter, and cover sheets are 1.0 width factor, regardless of height. */1/*

- Use the ARIAL.TTF font file for text less than or equal to 1/4 inch (6 mm).
- Use SWISS.TTF (Swis721 BT) font file for text larger than 1/4 inch (6 mm).

12-3.3.4.4 Translations.

Construction drawings are required to be prepared in dual language at a majority of overseas locations. For drawings developed in dual language, provide adequate space for the foreign language translation for objects such as notes, titles, and symbols. The final drawing must not appear cluttered or congested. Use italic font to distinguish the foreign language translation.

Location of translated text must be consistent across the drawing package, regardless of discipline. English on top, and the Host Nation language beneath, or on a following sheet when separate translation sheets are used. Refer below for acceptable locations:

- Translated text for Drawing Notes, Titles within the Drawing Area, and Symbols must be located directly beneath the English text.
- The following are acceptable locations for translated text pertaining to General Notes, Sheet Keynotes, or Schedules:
 - Beneath English text of each individual note or line item.
 - Grouped beneath the entire English General Notes, Sheet Keynotes, or Schedule table.
 - Where entire sheet consists of notes or schedules only, a separate translation sheet immediately following the English language sheet may be used. Use the preceding sheet number and NAVFAC number for the separate translation sheet.

Consult with the project PM and DM prior to developing sheet files to ensure concurrence.

12-3.3.4.5 File Naming Conventions.

Use File Naming Convention for CAD Files as specified in the DoD A/E/C standard except as noted in Figures 12-3 and 12-4 below:

Figure 12-3 Model Files

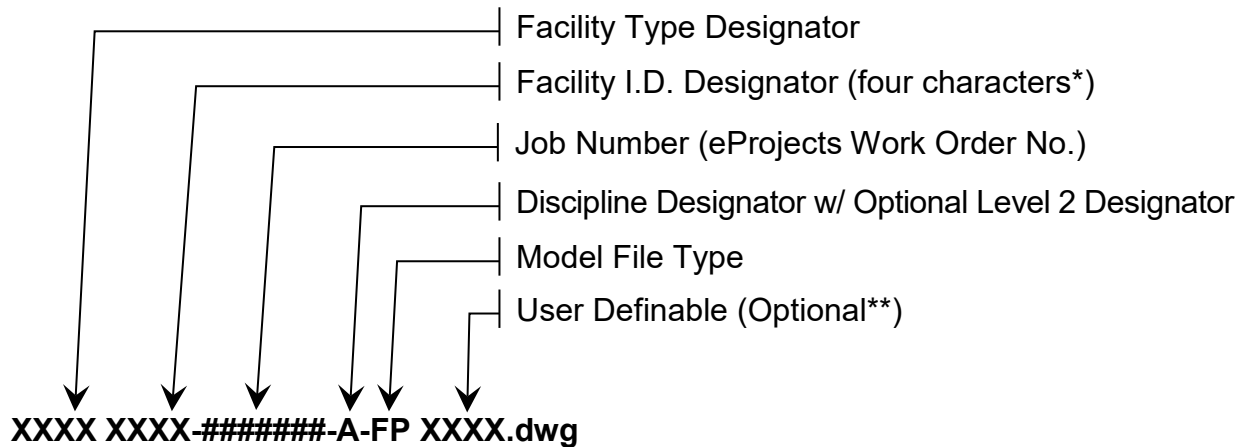
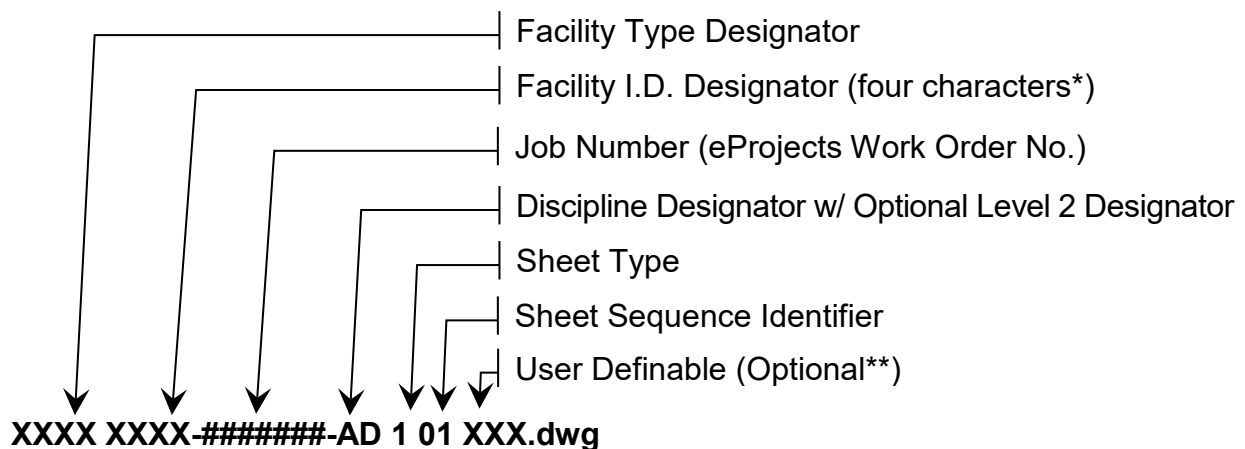

Figure 12-4 Sheet Files



* If no building designation has been assigned, such as for new construction prior to completion, then utilize the project number (P-number) for the Facility Type and I.D. designators. If installation has an alternate building identification system, that designator may be utilized in lieu of the Facility Type and Facility I.D. Designator.

** When used, typically the first two characters of the User Definable suffix address the floor number. Use the last two characters to further specify quadrants, phases, or

wings. For example: BLDG0001-eProjectWON-C-101-12.dwg; The User Definable suffix “-12” is used here on a Civil plan sheet where multiple tabs/layouts contain (12) adjacent sheets that are connected by match lines.

Model file types, sheet file types, and discipline designators are found in the DoD A/E/C CAD Standards. Obtain the Facility I.D. Designator and Job Number from the Contracting Officer.

12-3.3.4.6 Facility Type and I.D. Designators.

Use Facility Type and I.D. designators in Table 12-1.

Table 12-1 Facility Types and I.D. Designators

<u>Facility Type</u>		For Utility projects the Facility I.D. Designator must be as follows:	
AFLD	=	AIRFIELD	
BLDG	=	BUILDING	
DRDG	=	DREDGE	SWTR = SALT WATER
DRYD	=	DRYDOCK	FWTR = FRESH WATER
BRTH	=	BERTH	PWTR = POTABLE WATER
PIER	=	PIER	NGAS = NATURAL GAS
SLIP	=	WET SLIP	STEM = STEAM
PRKG	=	PARKING LOT	SSWR = SANITARY SEWER
ROAD	=	ROAD	STRM = STORM DRAIN
RAIL	=	RAIL	CAIR = COMPRESSED AIR
FENC	=	FENCE	POWR = POWER
GATE	=	GATE	COMM = COMMUNICATIONS
UTIL	=	UTILITY	CATV = CABLE TV
CRAN	=	CRANE	
		For Rail projects the Facility I.D. Designator must be as follows:	
		CRAN	= CRANE RAIL TRACK
		TRAK	= RAILROAD TRACK

12-3.3.5 Drawing Support Files.

Support files necessary for initializing, editing, and plotting drawing files must be a standard DWG or Microsoft Windows® component (or they must be an integral and standard component within the drawing file that require no third party custom utility or program to use). Support files include, but are not limited to, line types, hatch patterns, font styles, layer filters, display configurations and object styles. DWG files containing objects, styles, or definitions that require external files (such as SHX, LIN or LAY) to initialize, operate and display properly will be rejected.

12-3.3.6 Cost Estimates.

Submit the cost estimate as indicated in Chapter 9 with each submittal.11\ /1/

Use the following file naming convention for MII files incorporating the Award Fiscal Year (AFY) and WON:

AFY_WON_P#_Short Description_Location_Submittal_Date

Use the following file naming convention for the cost estimate package:

AFY_WON_P#_Short Description_Location_Submittal_Date_CEP

12-3.4 Preliminary Design Documents.

Preliminary design includes previous phases of design except for the Final Design phase. Source drawings and their associated PDFs must maintain a “PRELIMINARY NOT FOR CONSTRUCTION” stamp across the signature areas of the title block, until the actual final design submittal. The NAVFAC AutoCAD border has this block on the default layer “G-ANNO-TTLB-PRLM”. That layer must be frozen at the time of creating the final deliverables. Except for the final submittal, indicate the submittal phase designation, such as “PREFINAL”, after the project title on the coversheet of the drawings, and in the header and on the coversheet of the specifications or the RFP. Combine drawings into a single PDF file to facilitate ease of use unless file size requires a multi-file submission.

12-3.5 Final Design Documents.

12-3.5.1 General.

Convert source drawings to PDF format directly from their authoring software. Drawing PDF file sizes must be a maximum of 50Mb with digital signatures or a maximum of 50 sheets. There is no limit on file size for specifications or RFPs.

12-3.5.2 Format of Final Design Drawings.

Combine drawings into a single PDF file to facilitate ease of use unless file size requires a multi-file submission.

Bookmark PDF files and create visual “thumbnails.” Create a bookmark for the beginning of each drawing discipline. Create a sub-bookmark for individual drawing sheets. Bookmark wording must be as descriptive as practical (such as S-101 Foundation Plan). When complete, the files must open to the “bookmarks” view as the default view with the drawing sheets visible in “fit to page” magnification. Before submission to NAVFAC, the professional must electronically sign and seal sheets and appropriate locations on the NAVFAC Title Block(s). (See paragraph 12-4 NAVFAC Signature Electronic Requirements.)

12-3.5.2.1 Multi-File Drawings.

If the PDF drawing set must be broken into several PDF sets due to the file size restrictions given in paragraph 12-3.5.1 General, every attempt should be made to package complete discipline sets (do not break-up discipline specific sheets).

12-3.5.3 Format of Final Design Specifications.

Convert specifications to PDF format directly from their authoring software.

12-3.5.3.1 Preparation of PDF for Final Design Specification.

1. Merge PDF files for each section into one PDF file.
2. Combine the PDF files of the Coversheet, Table of Contents, and other project specific files including the Submittal Register. Insert blank pages where needed so that sections, graphics, and reports begin on an odd number page. Blank pages must include the following statement: "This Page Intentionally Left Blank." Create "thumbnail" images of each page. Refer to Chapter 8-6 for NAVFAC Coversheet location.
3. Bookmark the Coversheet, Table of Contents, each Division, Section, and inserted graphics, including the Submittal Register and Environmental Forms, following the respective UFGS section. Each Division bookmark must read "DIVISION XX - DIVISION TITLE", each Section bookmark must read "XX XX.XX XX - SECTION TITLE" and is a sub-bookmark of its corresponding division. SpecsIntact allows printing of the PDF in this format automatically; however, the coversheet and graphics must be inserted at the appropriate location and Bookmark.
4. Set the Document Properties of the PDF such that it opens to the first page and to the "bookmarks" view as the default view with the specification or RFP pages visible in "fit page" magnification.
5. Before submission to NAVFAC at Final, the principal design professional(s) must electronically sign the documents in accordance with paragraph 12-4 NAVFAC Electronic Signature Requirements.

12-3.5.4 Format of PDF for Final DB RFP.

Provide PDF of RFP following the requirements for Specifications in paragraph 12-3.6.2 Source Documents, except add a bookmark for each Part. Insert attachments following the same convention.

If the RFP contains drawings, provide a separate PDF for the RFP and the drawings. Typically, reference drawings are provided in Part 6. This should be a separate file because of the sheet size (11 x 17 inches (279 mm x 432 mm) or 22 x 34 inches (558.6 mm x 863.6 mm)) and will facilitate printing of this file separately by the Contractor.

12-3.5.5 File Naming Convention for Final Design PDF Files.

File naming convention for the final design drawings and specifications is shown in Figure 12-5 below:

Figure 12-5 File Naming Convention for Final Design PDF Files

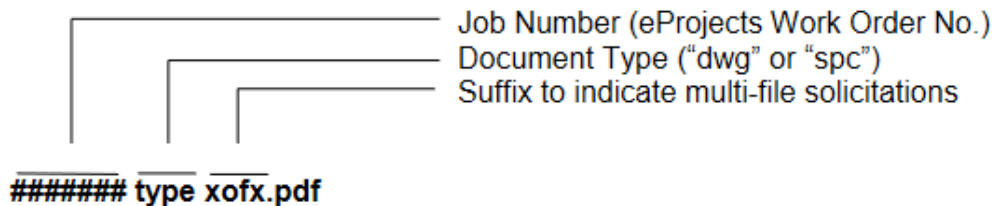

12-3.5.6 File Naming Convention for Amendments.

File naming convention for the Continuation Sheet is as follows:

Job Number (eProjects Work Order No.) Amend XXXX .pdf

For example, **5555Amend0001.pdf**.

File naming for attachments to the amendment follows guidance for naming specifications and drawings, with the exception that the amendment number must be included.

For example, **5555Amend0001dwg.pdf** or **5555Amend0001spc.pdf**

Combine attached drawing files into a single PDF file and attached specification files into a single PDF.

12-3.5.7 Password Protection of PDF Files.

Password protection to prevent changes to the PDF files is not allowed.

12-3.6 Record Documents.

12-3.6.1 Record Drawing Preparation.

Prepare Record Drawings in accordance with the drawing format guidelines of this Chapter and the following additional requirements. Make sheet changes \1\ directly in the authoring software format incorporating modifications and as-built conditions. In a BIM project, the authoring software DWG exports are from the BIM Record Model. /1/ Use the CAD standards used for the Contract Drawings Source Files for as-built modifications and the following guidelines:

- AutoCAD: Make revisions on the original layer of the object being changed. Draw a “cloud” around the changed portion and place it on layer Z-ANNO-REVC. Place revision symbols, notes, and “Record Drawing Stamp”, including those placed in each drawing’s revision block, on the Z-ANNO-REVS layer.
- Revit: Make revisions to the Record Model elements. Using per sheet revision numbering, add the required Sequence Number(s) / Letter(s), Description(s), and Date(s) for the Amendment(s) / Mod(s). Draw revision cloud(s) around the changed portion(s) at the sheet level and assign the proper Revision sequence. Tag the cloud(s). The Revision Schedule on that sheet will populate MARK, DESCRIPTION, and DATE for Amendment(s) / Mod(s) clouded on that sheet. Make date entry in format MMM YYYY (ex. SEP 2023).
- Place a “Record Drawing Stamp” on each drawing sheet, as illustrated in Figure 12-6 below, for maximum visibility without conflicting with other pertinent data:

Figure 12-6 Record Drawing Stamp Example



Provide the following information on the revision block of Record Drawings:

- Sheets with No Changes → **“As-Built”**
 - Sheets with revisions to match final field conditions → **“As-Built Conditions Shown”**
 - Cover Sheet → **“RECORD DRAWINGS INCLUDE AS-BUILT CONDITIONS AND MAY NOT MATCH THE ORIGINAL CONTRACT DRAWING SHEETS.”**
- Type in the signatures, initials, dates, and SAT-TO information, in the title block area on the contract drawings, as text on the record drawings. The record drawings are not signed again by the DOR. The record drawings do not have to be sealed, and the seal from the DOR is not transferred.
- Provide extra sheets as required to accommodate sketches, amendments, and field changes. Obtain NAVFAC drawing numbers from the Design Activity for added sheets; these numbers will be out of sequence for inserted sheets. Typically, use the previous sheet designation followed by “A,” “B,” and so on for inserted sheets. Update the sheet index to reflect the final record drawing titles, sheet numbers, and NAVFAC numbers.

- Upon completion of the drawing modifications, save drawing files named as specified in this chapter.
- Produce a PDF file of each individual record drawing using a PDF page size that corresponds to the original document sheet size. Provide a PDF print resolution that results in clear detail of drawing features. Electronic signatures are not required.
- For DB Contractor provided drawings, the RFP reference or definitive drawings are not required for inclusion in the Record set of drawings.

12-3.6.2 Source Documents.

In addition to the drawings, provide the specifications, design analysis, reports, surveys, calculations, and other contract documents utilized in creating the design package (drawings, specifications, and cost estimate) \1\ electronically on DODSAFE (<https://safe.apps.mil/>) or other approved secure site (coordinate with the Government Project Manager), \1\ as specified in paragraph 12-6.3 Minimum Record Drawing Submittal Requirements. Provide the cost estimate and cost estimate backup (such as, quantity take-off or material or equipment quotes) on separate media.

12-3.6.3 Record Drawing Source File Naming.

The file naming convention for record drawing sources is shown in Figure 12-7:

Figure 12-7 Record CAD Files

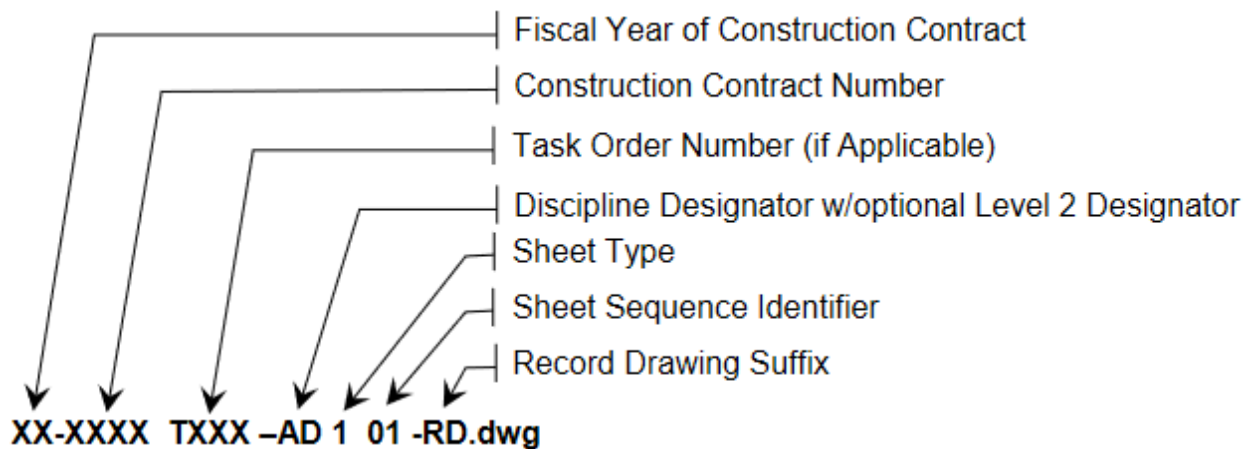

12-3.7 NAVFAC Supported EDD Standard Components.

The WBDG contains the following NAVFAC standards for use on developing project deliverables: NAVFAC Standard CAD title blocks (border sheet templates) and pen configuration table at <https://www.wbdg.org/navy/cad>.

The standard CAD templates have incorporated the NAVFAC standards along with the DoD A/E/C CAD and National CAD Standards (NCS). The templates are available in

AutoCAD and Revit. These templates are available for use, but NAVFAC does not guarantee that they are without error and are not responsible for inaccuracies. NAVFAC is continually updating and improving the templates.

12-4 NAVFAC ELECTRONIC SIGNATURE REQUIREMENTS.

Federal legislation has established the legality and acceptability of electronic signatures (in accordance with Public Law 106-229). NAVFAC requires the use of electronic signatures for the certification of drawings and specifications. The following sections outline the requirements for electronic signatures on NAVFAC deliverables.

12-4.1 General Requirements.

Prior to final NAVFAC signature, the following steps must be completed:

- Government Project Manager receives SATISFACTORY TO (SAT-TO) from the Client.
- Type “Approved By [Name of Client Representative] via [media (such as email or fax)]” in the ACTIVITY field, and the date the SAT TO was received, in the DATE field. SAT TO must appear on every drawing sheet in the CAD file.
- \1\ /1/
- Type in the initials of the “DES, DRW, and CHK” areas on the border to indicate the individual(s) who designed, drafted, and checked the sheet, respectively. These areas must display the responsible individual’s initials in the CAD file. The CHK initials CANNOT be the same as the DES and DRW initials.
- The “PM/DM, BRANCH MANAGER, CHIEF ENG/ARCH, and FIRE PROTECTION” fields are for use by NAVFAC \1\ and may be signed with Sign-it®, Bluebeam, /1/ or initialed with CAD text. \1\ Signatures in these fields must be /1/ a supervisor or has delegated signature authority under NAVFACINST \1\ 5216.10. The CHIEF ENG/ARCH CAD text can be changed to reflect the signatory’s title; if this field is not used, the CHIEF ENG/ARCH CAD text in this field must be removed. /1/ A signature block is shown in Figure 12-8.
- Provide an electronic seal in the title block labeled “SEAL” for each CAD sheet per the discipline responsible for the work contained on the sheet.
- \1\ The DOR must /1/ electronically sign the PDF of the specification coversheet (RFP coversheet for DB RFP Preparer) and \1\ /1/ the seal on each drawing PDF sheet, using Sign-it® \1\ or Bluebeam /1/. If the professional is required to submit “wet-signed” documents to be in compliance with their state regulations, then a separate “wet-signed” drawing and specification set may be submitted, meeting the requirements

of paragraph “Wet-Signed Documents”. A fully electronic solicitation, including electronic signatures is still required.

When the above steps are completed, NAVFAC will \1\ electronically /1/ sign the “For Commander NAVFAC” in the title block on each Drawing sheet and on the coversheet of the Specifications. This is required on final designs including designs prepared under DB contracts.

Figure 12-8 NAVFAC Signatures

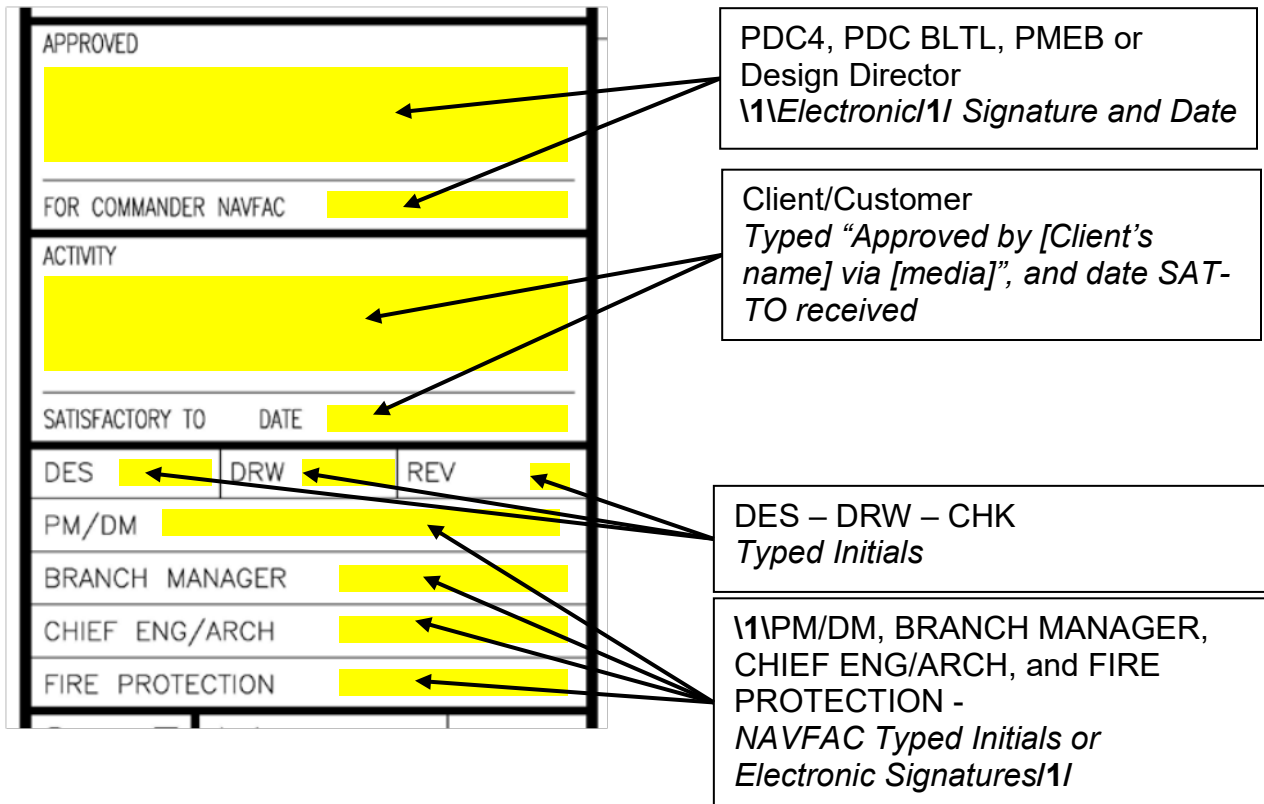

12-4.2 Specific Software Requirements.

Sign design documents using the Sign-it® \1\ or Bluebeam /1/ software. Current version information, points of contact, and order forms for Sign-it® are located on the WBDG (<https://www.wbdg.org/navy/cad>).

12-4.3 Wet-Signed Documents.

If required, produce wet-signed documents from the final electronic PDF documents (prior to electronic signature application) submitted to NAVFAC.

12-5 BUILDING INFORMATION MANAGEMENT/MODELING (BIM) REQUIREMENTS.

For projects that require BIM, comply with requirements for Drawings and as follows.

12-5.1 BIM Definitions.

12-5.1.1 BIM Project Execution Plan (PxP).

The DOR is responsible for the PxP, which is a mandatory document that identifies in detail: key contacts, quality control, software used, model organization, and project deliverables when designing with a BIM application.

Download the PxP file found on the NAVFAC BIM Page of the WBDG (<https://www.wbdg.org/navy/bim-eomsi>).

12-5.1.2 3D Parametric Modeling Application.

A software application which uses select criteria, parameters, and variables to determine the characteristics (including length, width, height) of a Model Element and defines relationships between other model elements.

12-5.1.3 Model.

A digital representation of the physical and functional characteristics of a facility or a part thereof, comprised of Model Elements with Element Data.

12-5.1.4 Model Element.

A self-contained object within a Model with a unique identification, whose behavior and properties are defined by data fields (Element Data). Model Elements can represent a physical entity, such as a pump or a concrete wall, and range from the simple (a standalone pump) to the complex (a multi-component wall system).

12-5.1.5 Element Data.

The non-graphical information of a Model Element that defines the various characteristics of the object. Element Data can include properties such as parametric values that drive physical sizes (length, width, height), material definitions and characteristics (wood, metal), manufacturer data, industry standards (AISC steel properties), and project identification numbers. The required Element Data fields can be found in the Required Facility Asset Fields of the Model & Facility Data Matrix tab in the eOMSI FDW.

12-5.1.6 Design Model.

The Model created and delivered by the DOR which is developed to a specific Level of Detail (LOD) as defined in the Model & Facility Data Matrix tab of the eOMSI FDW.

12-5.1.7 Record Model.

The Design Model modified by the KTR or DOR (depending on contract requirements/delivery method) which incorporates the real-world conditions of the facility as constructed.

12-5.1.8 Facility Data Workbook.

The Facility Data Workbook (FDW) defines the BIM Levels of Detail (LOD) required for each system, during design. The FDW is initially populated during design and completed during construction with the actual components and systems provided. The FDW is provided as part of UFGS 01 78 24.00 20 and required in accordance with paragraph 7-2 Building Information Management and Modeling (BIM).

12-5.2 Minimum Modeling and Data Requirements.

12-5.2.1 General.

Use 3D Parametric Modeling Application(s) to develop the Design Model(s) based on the project scope.

12-5.2.2 Model & Facility Data Matrix.

DOR completes the Model & Facility Data Matrix tab of the eOMSI FDW (XLS) utilizing the Instructions tab found in the eOMSI FDW. Download the eOMSI FDW from the NAVFAC BIM Page of the WBDG (<https://www.wbdg.org/navy/bim-eomsi>).

12-5.2.3 Model Files.

Produce an independent Design Model for each discipline that can be linked to each other. Document the Model names and Model links in the PXP.

12-5.2.4 Element Data.

Use the Required Facility Asset Fields (Element Data) specified in the Model & Facility Data Matrix tab of the eOMSI FDW for modeled elements.

12-5.2.5 Room Space Data.

Include room space data defining net square footage and net volume to develop the room finish schedule including room names and numbers.

12-5.2.6 Schedules.

Produce Schedules (Finish, Room, Lighting, Plumbing, Equipment, Openings) from the Model Elements and Element Data within the Model.

12-5.3 Design Model.

DOR develops the Design Model using a 3D Parametric Modeling Application to produce a complete set of Contract Drawings. Submittals must be compatible and editable using their native software as defined in the PxP.

12-5.3.1 Design Model Naming Convention.

Refer to Table 12-1 for the Facility Type and Facility I.D. Designators.

Use the naming convention found in Figure 12-9 for BIM Design Models files:

Figure 12-9 BIM Design Model Naming Convention

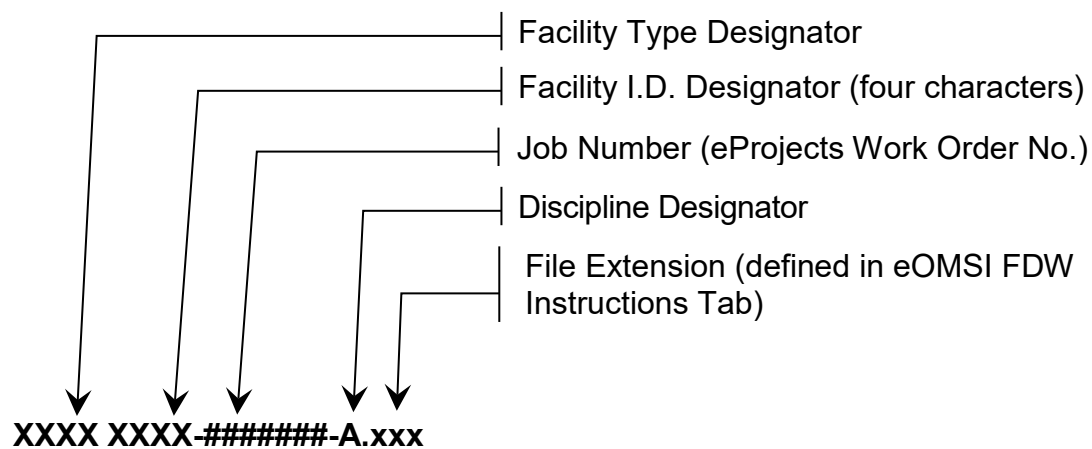

12-5.4 Record Model.

KTR develops the Record Model by modifying the DOR's Design Model as the facility is being constructed. Utilize the Record Model Grade specified in the Model & Facility Data Matrix tab in the eOMSI FDW.

12-5.4.1 Record Model Naming Convention.

The file naming convention for record models is shown in Figure 12-10 below:

Figure 12-10 Record Model Naming Convention.

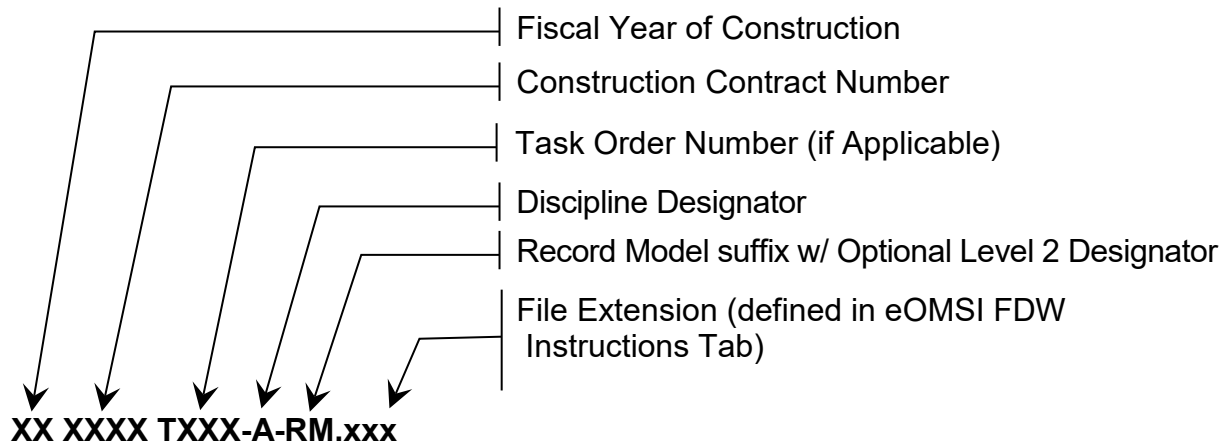

12-5.5 Drawing and Model Progression.

Model and Drawing naming conventions and procedures are indicated in Figure 12-11.

Figure 12-11 Drawing and Model Progression DBB

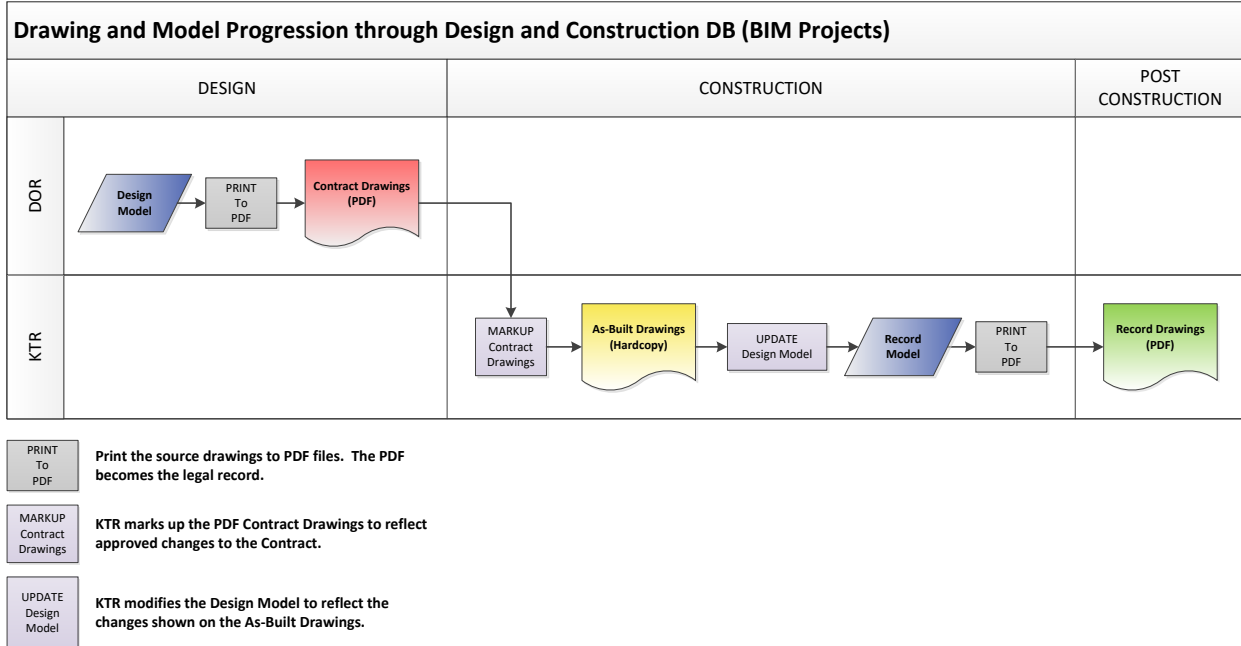

12-5.6 BIM Submittal Requirements.

12-5.6.1 Visual Review Report.

The DOR must produce a report (PDF) which compares the Mastersystems, Systems, and Subsystems list in the Design Model with the Mastersystems, Systems, and Subsystems list identified in the Model & Facility Data Matrix tab in the eOMSI FDW at each Design Phase. Identify discrepancies (omitted and unintended Model Elements) between the two lists, including an explanation for each. Address omitted and unintended Mastersystems, Systems, and Subsystems in the Design Model by Final Design. Provide a written explanation for omitted and unintended Model Elements that remain in the Design Model.

12-5.6.2 Clash Detection Report.

The DOR must conduct a clash detection of the Design Model at each design phase. Provide a report (PDF) at each phase showing existing clashes in the Model. The final Clash Detection report must reflect zero clashes.

12-5.6.3 Format of PxP in Preliminary Design.

Provide PDF file of PxP.

12-5.6.4 Format of Final Design Model.

Provide the final Design Model in native format and exported CAD files in DWG format.

12-5.6.5 Format of Final Record Model.

Provide the final Record Model in native format and exported CAD files in DWG format.

12-5.6.6 Facility Data Workbook (FDW).

Provide the Facility Data Workbook in Excel format.

12-6 EDD MEDIA AND ORGANIZATION.

12-6.1 General.

Provide Official submittals \1\ electronically on DODSAFE (<https://safe.apps.mil/>) or other approved secure site (coordinate with the Government Project Manager). *1/* Submit CAD files in native Drawing (*.DWG) format in the NAVFAC supported version. Drawing files must be uncompressed and unzipped. Purge files of unused items (blocks, layers, line types, and nested items). Do not submit single drawing files with multiple layouts except as described in paragraph 12-3.3.4.1 NAVFAC Standard Drawing Format. Do not bind cross referenced parent and child drawings. If the submitted native DWG files are not the native file format for the authoring software,

provide native design data in the original authored format in addition to the native DWG compliant format.

12-6.2 Minimum Final Submittal Requirements.

Provide the following as a minimum at final design submittal. NAVFAC Components may require additional submittals\1\ /1/.

\1\ /1/ #1 - Final Design or RFP for Government Signature\1\ /1/

Drawing PDF file(s) electronically signed by the Professional(s) in Responsible Charge

RFP or Specification PDF file electronically signed by the Professional in responsible charge in the "Submitted By:" Section

\1\ /1/ #2 - Source Files\1\ /1/

/CAD Native CAD Files for disciplines; include X-refs, images, or other external reference files.

/BIM (for BIM projects only) Native BIM models, PxP, Visual Review Report, and Clash Detection Report.

/eOMSI FDW

/Specifications folder - Specification source files

/PullData folder (*.sec files)

/RFP folder - Source files of RFP package, further divided by subfolders into Parts, except for specification section files or CAD files.

/Calculations folder (pdf and input/source files)

/Support folder

/Reports-Surveys - Studies folder

/Basis of Design folder

/Architectural Color Boards folder (photos)

/Other folder (such as Photos, Project background/support files)

\1\ /1/ #3 - Cost Data\1\ /1/

12-6.3 Minimum Record Drawing Submittal Requirements.

Submit 1\ record drawings /1/. Each must have the following folders and content.

/Record Drawings/

/CAD - Record CAD files and X-refs for disciplines must be stored in the same folder (directory).

/PDF

/Specs

/Calcs

/Cost

/Basis of Design

/Other

CHAPTER 13 PHASE: PRELIMINARY DESIGN: DON MILCON

13-1 GENERAL REQUIREMENTS.

Preliminary Design for the Department of the Navy, Military Construction (MCON) requires development of Preliminary Design Deliverables to ensure that projects submitted for Congressional and Presidential approval contain sufficient planning, accurate construction scope, adequate documentation, and a valid cost estimate for successful execution. For “Blue Navy” MCON projects, Preliminary Design begins upon substantial completion of advanced planning after the issuance of Budget Project Readiness Index (PRI) Authority (BPA). For “Green Navy” MCON, MCNR and Family Housing projects, Preliminary Design begins with issuance of Preliminary Design Authorization (PDA).

13-2 PRELIMINARY DESIGN.

Preliminary Design is authorized for development of Preliminary Design Deliverables including a budget-ready DD Form 1391 for submission into the Department of Navy’s (DoN) Military Construction budget, through the facility programming process. The purpose of Preliminary Design is to validate planning requirements and develop Preliminary Design Deliverables and cost estimate for MCON projects. Upon issuance of authority to start Preliminary Design, Preliminary Design Deliverables and a cost estimate are prepared to ensure MCON projects submitted for Congressional and Presidential approval contain sufficient planning, accurate scope, a minimum set of design deliverables, and a construction cost estimate for successful contract award and execution.

Preliminary Design Deliverables as described in this chapter do not have the same level of detail as the Schematic Design Submittal described in Chapter 14. Although many of the same requirements are contained in both submittals, they are developed for different purposes.

13-3 PROJECT PLANNING DD FORM 1391 ASSESSMENT.

Conduct an assessment of the existing project planning documentation, including the DD Form 1391, developed during the advance planning phase. \1\ Refer to the Consistency Review Board (CRB) Guidelines and DD Form 1391. /1/

13-4 ROLES AND RESPONSIBILITIES.

DD Form 1391 documentation is the combined result of a team project development effort from planning through the end of preliminary design. DD Form 1391 content is divided into blocks. Some blocks cover Designer or Project Manager prepared information, while other blocks are dedicated to Planning data. Responsible entities for DD Form 1391 content are as follows:

- Block 9, Cost Estimates: Project Team

- Block 10, Description of Proposed Construction: Project Team
- Block 11, Requirement: Public Works (PW) Directorate Real Property Manager and Activity/Region
- Block 12, Supplemental Data: PW Directorate Real Property Manager
- Block 12, Budget Estimate Summary Sheet: Project Team
- Block 12, Estimated Design Data: Project Manager
- Block 12, Equipment from Other Appropriations: Project Manager, PW Directorate Real Property Manager and Government Activity/Region

13-5 PRELIMINARY DESIGN DOCUMENTATION.

The project documentation establishes the basic requirements needed to meet the mission of the Support Command.

13-5.1 Preliminary Design Element.

Elements of the project documentation for most facility projects include: a DD Form 1391 in \1\ Programming Administration and Execution (PAX) /1/ format with detailed construction scope, collateral equipment list with cost, and preliminary budgetary cost information for primary facility and supporting facilities (for example, utilities, connections, and site work). Authority for Preliminary Design will only be issued once the advanced planning is substantially complete and the Project Planning DD Form 1391 sufficiently addresses the following elements:

- Site Identification & Approval
- Economic Analysis with updated costs
- Facility Planning Data
 - o Basic Facility Requirement (BFR)
 - o Facility Planning Document (FPD)
 - o Planning Study (for example, utility, traffic, asbestos, lead, radon)
- Equipment List and Cost
- Project Cost
- Environmental, Historic, Cultural Resources Impacts
- Project Requirements Schedule, and Engineering Studies (Utilities, Anti-Terrorism (AT), Physical Security, Geotechnical, Site, and Structural)

13-5.2 Preliminary Design File Naming Convention.

Use the file naming convention shown in Figure 13-1 for Preliminary Design files and Element Extensions provided in Table 13-1. \1\ This is required for uploading documents into PAX. /1/

\1\ /1/

Figure 13-1 Preliminary Design File Naming Convention

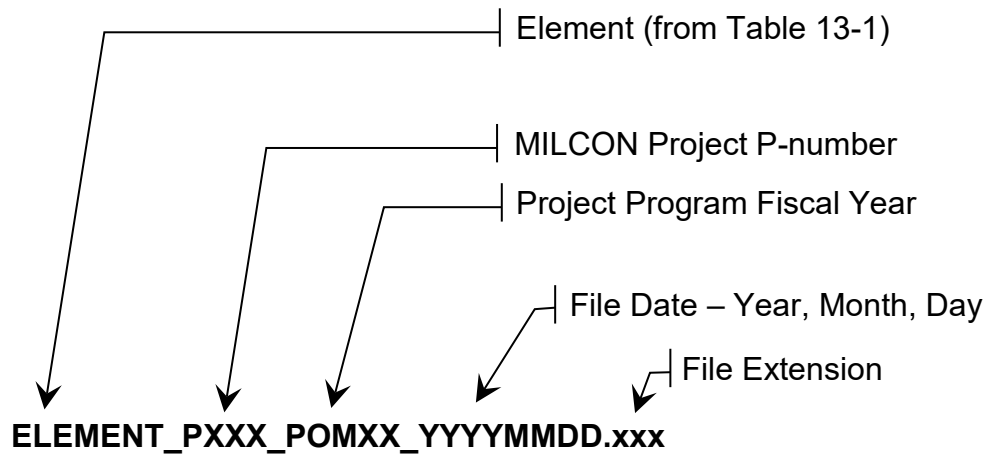

Table 13-1 Element Extensions and Examples

Element Description	Element	Example
Site Identification and Approval	SITE PLAN	SITE PLAN_P001_POM19_20150501
Economic Analysis	ECON ANALYSIS	ECON ANALYSIS_P001_POM19_20150501
Facility Planning Data	BFR	BFR_P001_POM19_20150501
	FPD	FPD_P001_POM19_20150501
Planning Study (Utility, Traffic, Asbestos, Lead, Radon)	PLAN STUDY	PLAN STUDY_P001_POM19_20150501
Equipment List	EQUIP LIST	EQUIP LIST_P001_POM19_20150501
Cost Estimate Package	CEPBKUP	CEPBKUP_P001_POM19_20150501
Design Deliverables	DDBKUP	445BDDBKUP_P001_POM19_20150501
Environmental & Cultural/ Historical Resources Impacts	ENV	ENV_P001_POM19_20150501
Engineering Studies (Utility, Independent Facility Structural, Seismic Assessments, Geotechnical, Energy, AT, Physical Security)	ENGR STUDY XXX (XXX = Type of Study)	ENGR STUDY UTILITY_P001_POM19_20150501

11 The exception to the naming conventions shown in Table 13-1 is for the MILCON Checklist, where FYXX is the fiscal year of the Project and PXXX is the Project's P-number. The submittal name is either RegFEC_Team_Final, Program_Final, or Certified_Final. See below Table 13-2. 11/

Table 13-2 MILCON Checklist File Naming Conventions

File Name
FYXX PXXX_MILCONChecklist_Submittal_Name

13-6 PRELIMINARY DESIGN CHARETTE.

Conduct a charrette with project stakeholders and multi-disciplines as applicable to develop Preliminary Design Deliverables. The multi-disciplinary design effort examines project functions, validates requirements, and analyzes alternate concepts.

13-6.1 Format.

The preliminary design charrette format consists of multiple work-sessions (usually 2-3 work-sessions), over a week-or-greater timeframe. Both the number of work-sessions and the time between work-sessions is dependent on project size and complexity, as well as the completeness of prior project planning efforts. Complete the site engineering investigation, described in paragraph 13-12 Cost Estimate, prior to or coincident with the preliminary design charrette.

Initial charrette work-sessions focus on validating project planning documents, analyzing project functions, and presenting notional concepts and alternatives for the site and facilities. The preliminary design charrette format is iterative; follow-on work-sessions feature presentation of revised project concepts and discussion leading to refinement of the product.

13-6.2 Participation.

Engage project stakeholders in the preliminary design charrette. As a minimum, include the following team members:

- Project Manager, Cost Engineer/Estimator and Project Technical Team, including the Design Manager, Architects and Engineers from disciplines needed to support the preliminary design.
- Customer Representatives, including but not limited to: End User, Project Sponsor, Subject Matter Experts.
- Base Facilities Representatives, including Planners, Utility Managers and Technical Staff, Installation Security Officer, Environmental Technical Staff, Construction Management Staff, Base Communications Officer (BCO), Cybersecurity Stakeholders (for example, NAVFAC Echelon IV CIO4 and CIO2).
- Privatized utility system owners.

13-7 IDENTIFICATION OF UNIQUE PROJECT REQUIREMENTS.

Identify and coordinate unique project requirements during the preliminary design charrette. Coordinate costing and development of unique requirements identified by the Project Technical Team, or other appropriate personnel, of issues not related to design. Unique requirements that are prone to be overlooked include:

- Construction restrictions due to airfield/waterfront operations

- Explosive Safety Site Approval
- Temporary facility requirements
- Laydown areas which may include offsite areas that increase project cost, such as batch plants for large pavement projects and stockpiling area for contaminated material
- Construction phasing requirements
- Locating property lines and other land restrictions, such as easements
- Security and Anti-terrorism requirements (Controlled Areas)
- Environmental issues, including hazardous material abatement, radon mitigation, permitting, and NEPA
- Cost of disposing hazardous materials
- Seismic, fire protection and sustainability triggers for renovation projects
- Host Nation Requirements (for overseas projects; for example, verify if energy or renewable requirements)
- On Installations with privatized utilities (such as gas, water, electric), coordination with the Privatized utility system owners for utility system connections and upgrades to the utility system. Utilities cannot be disturbed without the written consent of the privatized utility owner. Ensure utility system costs are included in the DD Form 1391.

13-8 DD FORM 1391.

Prepare updates to the project's DD Form 1391 documentation for submission in **V1\ PAX /1/**. Conform to the following, latest guidance provided by the Government MILCON Manager:

- Consistency Review Board (CRB) Guidelines & DD Form 1391 Development
- Budget Quality DD Form 1391 Editing and Style Guidelines
- POM Preliminary Design Guidance for applicable MILCON Program Budget Year

13-9 PRELIMINARY PROJECT NARRATIVE.

The project narrative, along with the drawings, documents the preliminary project design that facilitates the budget-ready project cost development. Preliminary design is driven by the requirements identified by Project Stakeholders, Government Project Planners, and applicable design criteria. The preliminary design is not constrained by a pre-determined budget.

Identify the following in the project narrative document:

13-9.1 Description of Proposed Construction.

Revise and enhance Block 10 statements in the prior DD Form 1391 that was prepared during planning. Prepare description of proposed construction in compliance with Block 10 requirements in “CRB Guidelines & DD Form 1391 Development” and “Budget Quality DD Form 1391 Editing and Style Guidelines.” Use verbiage prepared for this portion of the Project Program for Block 10 of the budget-ready DD Form 1391.

13-9.2 Project Objectives.

Identify the Mission Statement and Facility Function. Describe issues that need to be considered in future project development, including, but not limited to: Project Specific Priorities, Workflow Processes, Appropriate Design, Special Design Challenges, Adaptability and Flexibility, and target dates for Initial and Full Operating Capability (IOC/FOC).

13-9.3 Site Analysis.

Define existing site conditions and site development requirements. Identify constraints that restrict development. Project cost can increase for sites that are developable but constrained – and require special considerations to build on the site. Describe situations where the site location is associated with other-agency or Command approval processes (for example, NOSSA, SHPO, NEPA, NAVAIR). Refer to Paragraph 13-13 Site Engineering Investigation.

13-9.4 Building Requirements.

Develop the facility preliminary design concept. Describe primary blocks, such as, interior spatial areas, workflow/processes, functional relationships, circulation patterns, equipment/storage requirements, and security issues. Schematically tabulate facility floor area requirements on a room-by-room basis. Verify that floor plan area requirements identified by the functional analysis match Facility Planning Documents (FPD), prepared by Government project planners.

13-9.5 Host Nation Requirements.

For OCONUS projects, identify host-nation requirements, such as energy or renewable requirements or others.

13-10 DISCIPLINE-SPECIFIC BASIS OF DESIGN.

Develop separate and condensed summaries for core disciplines (in reference to the Core UFCs defined in UFC 1-200-01) including: Geotechnical, Civil, Landscape Architecture, Architectural, Structural, Fire Protection, Mechanical, and Electrical.

Provide sufficient definition in the discipline-specific Basis of Design to support the development of a cost estimate for that discipline.

13-10.1 Building Systems.

For the building systems (such as architecture, structural, mechanical, electrical, fire protection), identify the discipline-specific design assumptions, as required to support a parametric estimate on the Primary Facility. Consult with interior design personnel for select projects, where unique interior design requirements cannot be captured by standard parametric estimating techniques for the facility-type. Ensure that risks associated with facility systems identified, typically on the Preliminary Hazard List (PHL) or Preliminary Hazard Analysis (PHA) if developed prior to the Preliminary Design, are mitigated, or have engineering controls to eliminate the risk.

13-10.2 Site.

For the site, including utility systems (for example, civil, electrical, telecommunication) identify the design assumptions for Supporting Facilities, as required to support quantities and unit costs. Consult with landscape architecture personnel for select projects, where a portion of total costs may be associated with landscape architectural requirements.

13-10.3 Cybersecurity Impact Level.

Indicate the Cybersecurity Impact Level for the control systems. Provide project-specific requirements.

13-10.4 Ratio of Renovation Cost to Replacement Cost.

For renovation projects, provide an analysis of the ratio of renovation cost to replacement cost (see UFC 3-701-01 for the definition of replacement cost). Clearly identify ratios that trigger additional facility upgrades (such as AT, Physical Security, seismic evaluation and retrofit, and sustainability). Re-address the costs in the Economic Analysis provided from the Project Planning development phase.

13-10.5 Narratives.

In addition to basis of design narratives for core disciplines, provide separate narratives for the following cross-disciplinary elements. Devote special attention to issues that may have significant impact such as:

- AT – Discuss AT with the customer and identify AT requirements that have significant cost impact including full compliance with UFC 4-010-01 and progressive collapse avoidance.
- Sustainability – Indicate the feasibility of meeting Guiding Principle requirements and other sustainability goals for the project in accordance with UFC 1-200-02. Include a draft NAVFAC High Performance Sustainable Building (HPSB) Checklist. Where TPC is an anticipated requirement, develop a draft TPC checklist. Discuss the scope for

commissioning, to include systems to be commissioned, development of required documents, and Commissioning Provider contracting method.

13-11 PRELIMINARY DRAWINGS.

Prepare preliminary design drawings or sketches, for the purpose of:

1. Clearly illustrating the basic project scope to stakeholders, and
2. Supporting development of the parametric cost estimate.

Preliminary design drawings or sketches need not feature the level-of-detail or format specified in Chapter 7; especially where highly complex drawings could detract from the primary intent. Include the following:

- Vicinity Map and Location Plan
- Demolition Plan: Show facilities to be demolished (if required)
- Site Plan(s):
 - o Show the layout (size and possible shape) of the new facility in relation to major landmarks.
 - o Show the possible location of access roads, parking, landscaping, pedestrian walkways, plazas and patios, landscape structures, roads, and sidewalks, as applicable.
 - o Indicate approximate dimensions and orientation.
 - o Clearly indicate site constraints such as explosive safety arcs, flood zones, wetlands, or other environmentally sensitive areas.
 - o Where AT and Physical Security is applicable, clearly depict setback distances to vulnerabilities, including parking, roadways, and obstructions.
 - o Provide a Building Code site plan showing the assumed property lines of adjacent structures.
- Utilities Plans:
 - o Show utility lines and their points of connection in relation to existing adjacent structures, roads, and utilities.
 - o Show off-site utility upgrade requirements needed to support the project.
 - o Show civil, mechanical, electrical and telecommunication utilities to clearly convey the scope and quantities associated with various utility improvements.

- o On large utility distribution projects, provide one-line diagrams of electrical and telecommunication utilities.
- o Show mechanical building utilities coming into the building (for example, water, sanitary sewer, gas piping, and steam).
- Building Floor Plans:
 - o Provide floor plans depicting functional utilization of spaces. Incorporate Collateral Equipment (CEQ) and Furniture, Fixtures and Equipment (FF&E) into the design development and indicate on building floor plan(s).
 - o For renovation projects, provide separate drawings to identify existing conditions, demolition, and new construction elements.
 - o Provide mechanical and plumbing floor plans to include utilities coming into the building (for example, water, sanitary sewer, gas piping, and steam), and major pieces of equipment with clearances (for example, water, heater/storage tank, HVAC equipment, and pumps).
- Building Elevations: Provide elevations that depict the building character and indicate materials.

13-12 COST ESTIMATE.

Cost estimate class requirements are a minimum Class 3 in accordance with AACE RP 56R-08. NAVFAC Headquarters may issue project specific guidance at Preliminary Design start. Cost estimate methodology and cost tools are addressed in Chapter 9.

Project definition deliverables are required to be commensurate with the required estimate class. Refer to Appendix B, Table B-1 for class-specific project definition deliverables requirements. Appendix B, Table B-2 is the minimum requirement for Preliminary Design.

13-13 SITE ENGINEERING INVESTIGATION.

Supplement known site information/studies and examine high risk cost elements by conducting on-site utility investigation and site engineering studies to include soil borings and analysis, topographic analysis, fire flow tests, and flood projections and mitigation studies.

Evaluate if site information obtained as part of the preliminary design effort is sufficient to proceed with the full-design of the proposed facility. If sufficient data is not available, provide a list of additional site investigation needed to proceed with design.

13-13.1 Utility Investigation.

Locate and identify the nearest points of connection for utilities. If the points of connection are outside the project boundaries, provide additional information that shows the locations.

- Verify Project Planning DD Form 1391 identified point of connection.
- Retrieve and review the Installation's utility plans and consult with Government utilities personnel; where utility systems are privatized, consult with privatized utility system owner.
- Validate adequate utility capacities at points of connection.
- For Government-owned utility systems, conduct waterflow testing in accordance with UFC 3-600-01; for privatized utility systems, request waterflow testing data from privatized utility system owner.
- For utilities projects: Retrieve and review the utility study that supports the scope and type of work to be performed.

13-13.2 Subsurface/Geotechnical Investigations.

Consult with a Geotechnical Engineer to determine if the site can be characterized and foundation systems conceptualized based on known geologic conditions. If known geologic data can be used, the Geotechnical Engineer must document in the Basis of Design that the conceptual design for pavement and foundation design is based upon available soils information.

If existing geological data is not sufficient, and for large projects with anticipated Special Foundation costs (for example, pile foundations, mat foundations, significant grading and over-excavation, ground improvement), conduct a full soils investigation at the preliminary design stage. Perform foundation and soils investigations, including sampling, testing, and evaluation, with requirements set forth in Chapter 4. If ground source heat pumps are being considered, determine the soil characteristics for the geothermal well field.

13-13.3 Topographic Survey.

Utilize existing topographic data to the maximum extent possible.

For projects where costs associated with grading and dredging are significant, conduct topographic surveys at the preliminary design stage. Conduct topographic surveys in accordance with Chapter 4. Topographic Surveys must indicate significant site elements, including, but not limited to, utility points of connection, natural resource boundaries, fish and wildlife habitats (including buffer zones), rookeries, wetlands, and other environmentally sensitive areas.

13-13.4 Existing Building Surveys.

For repair, renovation, or rehabilitation projects, perform engineering studies to assess extent of the work, and to provide budget-level costs. These studies include, but are not limited to, structural, electrical, mechanical, fire protection, AT, Physical Security, building envelope, accessibility, and roof systems and components.

When triggered, conduct Tier I or Tier II seismic evaluations in accordance with UFC 3-301-01 and identify mitigation costs. Defer Tier III investigations until subsequent design phases (Final Design Authority, FDA). For renovations of historic properties: Coordinate with the NAVFAC Environmental Cultural Resources Office to determine special construction elements and other project constraints. For fire protection requirements, refer to the paragraphs titled "Planning" and "Existing Facilities" in UFC 3-600-01.

13-13.5 Hazardous Materials Investigation.

Validate and address findings from Field Investigation Report conducted during planning prior to Preliminary Design and conducted in accordance with UFC 3-810-01N. Hazardous Materials, along with their associated costs, must be identified and addressed in the DD1391. MCON Design Appropriations may only be used for comprehensive investigations hazardous materials investigations that are directly in support of a project design solution. For example, investigations that directly support development of design drawings and specifications.

13-13.5.1 Survey and Research.

As a minimum, for budget-ready costs, conduct a visual survey of existing field conditions. Consult with Government Environmental personnel, and research records for existing hazardous materials documentation and known site contamination issues. Determine if the site is part of an installation restoration program/project. Base the preliminary design on conservative assumptions from the visual survey and records search.

13-13.5.2 Demolition, Renovation, Repair, or Contaminated Sites.

For projects that include significant demolition, renovation, or repair, or sites with significant known environmental contamination issues, verify the presence of hazardous materials such as, but not limited to, asbestos, RCRA 8 metals (arsenic, barium, cadmium, chromium, lead, mercury, selenium, and silver), PCB, and mercury. For specific requirements, comply with UFC 3-810-01N.

13-13.6 Building Code Assessment of Adjacent Structures.

When the proposed construction is within 60 feet (18.3-m) of existing adjacent structures, conduct a building code assessment of the adjacent structures. Information about adjacent structures must include construction type, fire resistive rating of exterior walls, wall openings, number of floors, area per floor, total building area, occupancy classification, and if the building is fully protected with an automatic fire sprinkler system. The purpose of obtaining this information is to assure the new building (or addition) does not encroach on minimum separation requirements or assumed property line based on the design assumptions and building code analysis of the existing building(s).

13-14 CALCULATIONS.

13-14.1 Plumbing.

Provide the following plumbing calculations:

- Domestic water size coming into the building (looking for a preliminary calculation on the water size. Needed to determine if the existing water main has the size/capacity for demand).
- Available Water pressure (If the water pressure is suspect, a water pressure calculation is needed to determine if domestic water pump is required).
- Water Heater Size/Storage (preliminary calculation on the water heater/storage tank size).
- Sanitary sewer size coming into the building (preliminary calculation on the sanitary sewer size to determine if the existing main has the size/capacity for demand).
- Sanitary Sewer piping elevation/slope (preliminary calculation to determine if a grinder pump is required).
- Building Utilities (such as Steam and Gas) (preliminary calculation on the utility size to determine if the existing main has the size/capacity for demand).
- Sustainability (such as solar hot water or rainwater harvesting).
- Preliminary calculations and LCCE as needed to support position.

13-14.2 Mechanical.

- Building Cooling Load (Block Cooling Load Calculation)
- Building Heating Load (Block Heating Load Calculation)
- ASHRAE 62 Calculation (preliminary Calculation needed for DOAS systems).

- Preliminary Equipment Sizes (with clearances to size mechanical rooms if required).
- Life Cycle Cost Analysis (LCCA) (Performed on the mechanical systems such that a single system is selected during Preliminary Design.)
- Commissioning/Acceptance (determine if required for cost estimate).

13-14.3 Fire Protection.

Provide water supply and fire flow calculations. Refer to UFC 3-600-01.

CHAPTER 14 PHASE: SCHEMATIC DESIGN SUBMITTALS (10-15%)

14-1 GENERAL REQUIREMENTS.

The Schematic Design Submittal is intended to convey the extent of the work in a preliminary conceptual manner. Deliverables are approximately 10% to 15% complete at this stage. Appendix B Preliminary Design requirements may not apply for non-Preliminary Design projects. In addition to the requirements of the Core UFCs and the contract, include the deliverables described herein, as a minimum.

14-2 DB SCHEMATIC DESIGN SUBMITTAL.

For DB, if defined by the RFP, the Schematic design may be the Contractor's technical response to the RFP, including layout, functional drawings, and design. When this is used, exceptions to the UFC requirements must be outlined in the RFP solicitation.

14-3 BASIS OF DESIGN.

The discipline-specific Basis of Design needs to provide sufficient definition to support the development of a Class 4 cost estimate for that discipline. Submit a preliminary version of the Basis of Design addressing items defined in the contract, the Core UFCs, Chapter 5, and as follows.

14-3.1 Geotechnical.

Include the Geotechnical Report, if available, as an appendix. It is encouraged to have this report at this submittal to obtain review comments at the earliest possible date.

14-3.2 Sustainability.

Provide completed HPSB Checklist(s) and TPC Checklist(s) (where applicable) for each applicable building in the project. Provide copy(ies) of TPC registration information (where applicable), and comprehensive Sustainability Chapter.

14-3.3 Cybersecurity.

Provide a single submittal indicating criteria and describing requirements for integrating cybersecurity into the design and construction of the FRCS. The basis of design must describe specific guidance for control systems with the assigned Confidentiality, Integrity and Availability (C-I-A) impact ratings and must list the security controls with recommendations and justifications for future tailoring of the security control set. /1/ For existing building work, include documentation of existing FRCS infrastructure and how new work is integrated. /1/

14-4 DRAWINGS.

Provide drawings required by the contract, the Core UFCs, and herein as applicable to the project:

14-4.1 Architectural.

- Floor Plans – Provide floor plans, new and demolition, indicating room names and basic dimensions.
- Building Elevations – Provide building elevations indicating exterior materials.
- Building Section – Indicate heights of critical building elements.

14-4.2 Civil.

- Schematic Site Plan - Indicate above and below grade utility lines, vehicular and pedestrian circulation paths, buildings, parking, paved areas, and existing site features to remain.
- AT Standoff Distances.

14-4.3 Landscape Architecture.

- Site Inventory and Analysis Plan.
- Schematic Landscape Site Plan - Indicate buildings, existing site features to remain, utility lines and improvements, vehicular and pedestrian circulation, hardscape, plazas and patios, walls, structures and other above ground features, streetscapes, planting concept, Low Impact Development (LID) and other bio-retention areas.
- AT standoff distances.
- Provide types and purpose of plant materials used on the plan (for example, tall broadleaf evergreen shade tree or medium-sized flowering accent tree).
- Provide type of irrigation, water source, and how it is controlled.
- Provide additional information unique to the project.

14-4.4 Electrical.

Provide the following in accordance with UFC 3-501-01. The drawings need not provide extensive details but must be complete enough to thoroughly express the Designer's intentions:

- Existing Site and Demolition Plan.
- Site Plan.

- Single Line Diagram.
- Preliminary floor plans with dedicated space clearly identified for electrical and telecommunications rooms.

14-4.5 Fire Protection.

Provide the following. The drawings need not provide extensive details but must be complete enough to thoroughly express the Designer's intentions:

- Code Compliance Summary Sheets.
- Life Safety Floor Plan. At a minimum, identify building areas having different occupancy and hazard classifications and identify egress travel requirements.
- Fire Suppression Plans. At a minimum, provide floor plans identify hazard classifications. Where a facility has multiple hazard classifications, differentiate each classification area by border or hatching. Identify areas to be protected with special fire suppression systems.

14-4.6 Geotechnical.

Boring log drawings are encouraged but not required.

14-5 BIM PXP.

Provide a completed PXP within 30 days after the Charrette, Functional Analysis Concept Developments (FACDs) or Design Kick-Off Meeting for government review and approval. Format in accordance with Chapter 12.

14-6 CALCULATIONS.

Provide calculations complete and in sufficient detail to support the items outlined in the preliminary Basis of Design, as indicated on the drawings, in accordance with the Core UFCs, Chapter 6, and as follow:

14-7 SUSTAINABILITY.

14-7.1 TPC Registration.

When TPC is required in accordance with UFC 1-200-02, register each applicable building in the project with TPC organization within 30 days of the design kickoff meetings.

14-7.1.1 Format.

Use the following format to register with TPC:

- Project Title First Line: U.S. Navy or U.S. Marine Corps, Building Name (if applicable)
- Project Title Second Line: P-(#); (DD Form 1391 Project Name)
- Project Address First Line: UIC (Installation Code)
- Category Code: RPUID (Real Property Unique Identifier) Number
- Project Owner Organization: U.S. Navy or U.S. Marine Corps
- Primary Contact, Owner: NAVFAC Project Manager
- Additional Contact, Bldg. Owner: Choose Either: Public Works Officer/Deputy Public Works Officer or a Designee

14-7.1.2 Management and Documentation.

Provide TPC management and documentation online (or offline, with secure facilities) throughout the design of the project. Maintain TPC Checklist and obtain TPC Design Review.

14-8 CHARETTES AND FUNCTIONAL ANALYSIS CONCEPT DEVELOPMENT (FACD) STUDIES.

Charrettes and FACDs may be used in DBB to develop the design of the project or in DB to develop the Project Program in the RFP. Both use value-engineering techniques to develop concept designs. The formal Value Engineering process is required for DBB MCON projects over \$30 Million and is suggested for other high value multidisciplinary DBB projects. Provide charrette or FACD when required by the contract, and the formal Value Engineering process defined in the contract.

14-8.1 Description.

FACD studies and design charrettes are cooperative efforts by the design team, user and client representatives, installation planning staff, DD Form 1391 project team members, other appropriate Regional staff, facility engineering command personnel, and other interested parties. A charrette may last one to three days, while a FACD may last one to two weeks. They include on-site development of a Schematic design in response to functional, aesthetic, environmental, base planning, site, budgetary, and other requirements. Submittals include meeting minutes, schematic design, and documentation of the decision and information that led up to that decision, including a partnering agreement signed by the principal participants.

CHAPTER 15 PHASE: DESIGN DEVELOPMENT SUBMITTALS (35% - 50%)

15-1 GENERAL REQUIREMENTS.

The Design Development Submittal is intended to convey the complete extent of the work in a preliminary manner. The deliverables are typically about 35% to 50% complete at this stage. Update and include submittals from the previous submittal stage and provide additional detail to bring them to the required completion percentage. In addition to the requirements of the Core UFC's and the contract, include the following as a minimum:

15-2 BASIS OF DESIGN.

Update and submit a complete Basis of Design addressing items defined in Chapter 5 and the Core UFCs.

15-2.1 Sustainability.

Provide updated HPSB Checklist(s) and TPC Checklist(s) (where applicable) for each applicable building in the project. Provide updated Sustainability Chapter.

15-3 DRAWINGS.

Provide updated drawings from the previous submittal and additional drawings required by the contract, the Core UFCs, and herein as applicable to the project. Plan views, including enlargements, and excluding Site Plans, must include vertical and horizontal column lines within the range of the view.

15-3.1 Architectural.

- Legend and Abbreviations
- Floor Plans – Provide floor plans, new and demolition, indicating room names and dimensions
- Building Elevations – Provide building elevations indicating exterior materials
- Roof Plan – Provide a plan of roof areas, indicating direction of slope and method of drainage
- Building Section – Indicate heights
- Typical Wall Sections – Provide sufficient wall section(s) to indicate materials and different conditions
- Finish Schedule – Indicate proposed finishes

15-3.2 Interior Design.

Provide Structural Interior Design (SID) to include the following:

- Interior and Exterior Material and Finish samples in loose format
- FF&E Plan indicating built-in and movable items
- FF&E Summary List corresponding to the FF&E Plan with estimated item costs

15-3.3 Landscape Architecture.

- Overall Landscape Site Plan. Provide an overall landscape site plan with matchlines (if site plan is divided into multiple sheets) and specific sheet references, general notes, and options (if applicable).
- Landscape Site Plan. Provide enlargement plans as required to delineate appropriate detail.
- Landscape Construction Details.
- Landscape Planting Plan.
- Plant Material Schedule and Details.
- Landscape Irrigation Plan. When a Landscape Irrigation Plan is required by the Statement of Work, provide a sprinkler head layout, remote control valves, automatic controller, pressure pipe and lateral lines, backflow prevention device, and point of connection.
- Landscape Irrigation Equipment Schedule and Details. When a site irrigation plan is required by the Statement of Work, provide an irrigation equipment schedule.

Drawings indicated above can be combined. Contact Government's Landscape Architectural Reviewer for approval of combined drawings prior to project submittal. For example, on small projects a Landscape Site Plan and Landscape Planting Plan can be shown on the same sheet.

15-3.4 Geotechnical.

- Results of subsurface investigation, such as boring logs, test pit logs and laboratory test results, and special site preparation requirements.

15-3.5 Civil.

- Cover sheet, Drawing Index, Vicinity Map, Location Plan, Abbreviations, Legend and Notes.
- Existing Conditions / Demolition Plan.
- Site Plan.

- Water and Sanitary Sewer Plan.
- Grading and Drainage Plan.

Drawings indicated above can be combined. Contact Government's Civil Reviewer for approval of combined drawings prior to project submittal. For example, on small projects, a Site and Water and Sewer Plan can show the Site Plan and Water and Sanitary Sewer Plan on the same sheet or, the Site and Grading and Drainage Plan can show the Site Plan and Grading and Drainage Plan on the same sheet.

15-3.6 Structural.

- Foundation Plans. Include for structures, showing dimensions, arrangements, elevations, locations referred to a column line grid system, type of foundation and foundation obstructions. Include the layout of parts, including but not limited to, slabs, footings, piers, grade beams, and piles, showing foundation features of the design.
- Framing Plans. Include a framing plan for each structural level of the facility, showing dimensions, elevations, and column locations and numbering referenced to a column line grid system, and overall sizes of major members and components. Show the layout of system, including, but not limited to, beams, joists, and stringers.
- Structural Details. Show typical details of construction, indicating the connection and relationship between major components of the structural system.
- Structural Elevations. Show general sizes, location, and arrangement of significant features of the vertical framing system, such as columns, walls, and beams.
- Structural General Notes.

15-3.7 Mechanical.

- Plumbing Floor Plan. Show plumbing fixtures, floor drains and equipment locations.
- Site Plan. Show connections, such as to base steam distribution, location of propane and oil tanks, and layout of ground coupled heat pump well fields.
- HVAC Floor Plan. Show equipment locations, one or two-line duct layout and preliminary piping runs.
- Mechanical Room Plan. Show major equipment and maintenance access space. Provide section view(s) to clarify layout and supports.

15-3.8 Electrical.

- Existing Site and Demolition Plan.
- Site Plan.
- Single Line Diagram.
- Preliminary floor plans with dedicated space clearly identified for electrical and telecommunications rooms.
- Legend and Abbreviations.
- Lighting Plan(s).
- Power Plan(s).
- Lightning Protection Plan.
- Cathodic Protection Plan.
- Communications Plans.
- Special Systems Plans.
- Additional Plans/Risers.

15-3.9 Fire Protection.

- Code Compliance Summary Sheets (Updated from Schematic Design Submittal).
- Life Safety plan (Updated from Schematic Design Submittal). Identify locations of fire rated partitions and horizontal exits).
- Fire Suppression plans. (Updated from Schematic Design Submittal. Refer to Chapter 7-11, except that cross-sectional elevations/details of suppression system risers are not required at this submittal phase.)
- Fire Alarm and Mass Notification System Plans. (Updated from Schematic Design Submittal. Refer to Chapter 7-11.)
- Detail Sheets. (Updated from Schematic Design Submittal. Refer to Chapter 7-11.)

15-4 BIM DESIGN MODEL.

Provide Visual Review Report and Clash Detection Report.

15-5 OUTLINE SPECIFICATIONS.

Provide outline specifications, in the form of a list of specification sections the DOR intends to use in the job.

Use Unified Facilities Guide Specifications, as required in Chapter 8. Provide a listing of the UFGS used in the job by Section Number, Title, and Section Date. Follow the Order of Precedence for choosing UFGS master guide specifications in Chapter 8, unless required otherwise by the contract.

15-5.1 eOMSI Facility Data Workbook (FDW).

Provide Model & Facility Data Matrix tab of the Facility Data Workbook in sufficient detail to document the level of design completed in this phase. The FDW is an attachment to UFGS 01 78 24.00 20 in subsequent phases. The Facility Data Workbook is available for download at <https://www.wbdg.org/navy/bim-eomsi>.

15-6 CALCULATIONS.

Provide calculations complete, and in sufficient detail to substantiate the design level in this preliminary Basis of Design, as indicated on the drawings, in accordance with the Core UFCs, Chapter 6, and herein, and updated from the previous design phase.

15-6.1 Structural and Geotechnical.

Provide Structural and Geotechnical calculations in sufficient detail to support the items outlined in the Basis of Design and indicated on the drawings.

15-6.2 Civil.

Provide calculations in sufficient detail to indicate compliance with LID criteria, Navy LID Policy, and state or local stormwater regulations. Provide calculations for utility systems and pavements in sufficient detail to support items outlined in the Basis of Design and indicated in the drawings and specifications.

15-6.3 Architectural.

Provide acoustical calculations in accordance with UFC 3-101-01.

15-6.4 Mechanical.

Provide a bookmarked Adobe PDF \1\1/ of input and output data, and summary sheets for Energy Analysis, Life Cycle Cost Analysis, Building Heating and Cooling Loads, and ASHRAE 90.1 Compliance Calculations in accordance with UFC 3-410-01.

15-6.4.1 Energy Analysis.

Provide an Adobe PDF copy of the computerized energy analysis that includes input and output data in their entirety.

15-6.4.2 Life Cycle Cost Analysis.

Submit the computerized LCC analysis utilizing the latest edition of the NIST Building Life-Cycle Cost Program.

15-6.4.3 Building Heating and Cooling Load.

Provide an Adobe PDF copy of the computerized load calculations with input and output data in their entirety.

15-6.4.4 ASHRAE 90.1 Compliance Calculations.

Submit calculations and compliance forms indicated in the Basis of Design.

15-6.4.5 Plumbing Calculations.

Provide Design Basis in accordance with UFC 3-420-01.

15-6.5 Electrical.

Provided calculations required by Core UFCs and also include:

- Load Analysis.
- Service size.
- Feeder size.
- Larger special circuit sizes.
- Lightning Risk Assessment.

15-6.6 Fire Protection.

Submit calculations supporting fire suppression and fire alarm/detection systems for the project. Calculations for systems, features, or elements other than fire suppression or detection will be required as applicable. Fire suppression system calculations must be prepared using commercially available computer software.

15-6.7 Environmental Report.

Provide reports in accordance with UFC 3-810-01N.

15-7 QUALITY CONTROL (QC) REVIEW AND DOCUMENTATION.

15-7.1 Review.

Provide a quality control review by a third party not involved in the design of the project. Evaluate both technical accuracy and discipline coordination. The QC review must include, but is not limited to, the following:

- Eliminate errors, omissions, interferences, and inconsistencies among design disciplines and among drawings, specifications, and cost estimates.
- Verify current criteria, lessons learned, and responses to approved review comments are incorporated.
- Ensure the constructability of the facility as detailed in the drawings, specifications, and technical documents.
- Ensure documents are biddable.

15-7.2 Documentation.

With the submittal, provide Design Quality Control (DQC) documentation that demonstrates that cross-checking of documents has taken place. Provide a single set of documents highlighted to validate that the review was performed, and that the corrections were made.

This Page Intentionally Left Blank

CHAPTER 16 PHASE: PRE-FINAL DESIGN SUBMITTALS (100%)

16-1 GENERAL.

The intent of the Pre-Final submittal is to provide a complete set of design deliverables. The following are the minimum requirements of a Pre-Final submittal:

16-2 BASIS OF DESIGN.

Submit Basis of Design for each of the core disciplines, including updated information and incorporating responses to previous government review comments.

16-2.1 Geotechnical.

The Geotechnical DOR must validate that findings and design recommendations from the latest edition of the Geotechnical Report are valid, and construction and site preparation recommendations have been correctly incorporated into the pertinent drawings and specifications. Provide a draft verification letter from the Geotechnical DOR, certifying that a review of the Pre-Final drawings and specifications, as they relate to the Geotechnical Report, has been conducted and that these drawings and specifications comply with the Geotechnical Report findings and recommendations.

The Geotechnical Report, if modified during the previous review, must be re-submitted as an appendix to the Basis of Design; otherwise, do not submit.

16-2.2 Sustainability.

Provide updated HPSB Checklist(s) and TPC Checklist(s) (where applicable) for each applicable building in the project. Provide updated Sustainability Chapter.

16-3 DRAWINGS.

Drawings must be 100% complete, minus final signatures, and incorporate responses to the previous review comments. The drawings must be complete to the extent that they may be released for bid or constructed as submitted. Provide a complete set of construction drawings organized by discipline as described in this document and the Core UFCs. Upon submittal of the Pre-Final package, request NAVFAC Drawing Numbers from the Government. For DB projects, follow the requirements of the RFP when shop drawings are used as design drawings.

Provide drawings updated from the previous submittal level, drawings specified in the Core UFCs, Chapter 7, and the following, as a minimum:

16-3.1 Civil.

Provide updated drawings from the previous submittal and the following:

- Water, Storm and Sanitary Sewer Profiles

- Site / Utility Details.

16-3.2 Landscape Architecture.

Provide updated drawings from the previous submittal to substantiate design level, and the following, in accordance with UFC 3-201-02:

- Landscape Irrigation Plan. When a site irrigation plan is required by the Statement of Work, update irrigation system with pipe sizing and remaining associated requirements for a complete and operational system.
- Landscape Irrigation Equipment Schedule and Details. When a site irrigation plan is required by the Statement of Work, update irrigation equipment schedule. Provide irrigation details.

16-3.3 Electrical.

Provide updated drawings from the previous submittal to substantiate design level, and the following in accordance with UFC 3-501-01:

- Existing Site and Demolition Plan.
- Site Plan.
- Single Line Diagram.
- Legend and Abbreviations.
- Lighting Plan(s).
- Power Plan(s).
- Lightning Protection Plan.
- Cathodic Protection Plan.
- Special Systems Plans.
- Additional Plans/Risers.
- Lighting: Interior and Exterior Foot-candles.
- Load Analysis.
- Service size.
- Feeder size.
- Larger special circuit sizes.
- Lightning Risk Assessment.
- Communications Riser Diagram.
- Intercommunication Riser Diagram.

- Other Riser Diagrams for Television, Security, and similar systems.
- Panel Schedules.
- Switchboards and Motor Control Center Schedules.
- Lighting Fixture Details.

16-4 BIM DESIGN MODEL.

Provide Visual Review Report and Clash Detection Report.

16-5 SPECIFICATIONS.

Provide edited, marked-up specification sections, using the SpecsIntact “Show Revisions” function when editing and printing, to show deletions from and additions to the UFGS master sections. Use the default settings in SpecsIntact that displays deletions lined out and additions underlined. Run verification reports when printing. Print project specification sections, using the SpecsIntact “Show Section Dates” function, to display the official date of release of the master guide specification and version of the specification used. This date appears immediately below the specification section title.

Design submittal must be complete at this stage and require only minor corrections if any. Organize specifications in accordance with Chapter 8. Provide a submittal register with the specifications.

16-5.1 Sustainability.

Attach completed HPSB Checklist(s) and TPC checklist(s) (where applicable) for each applicable building in the project to UFGS 01 33 29.

16-5.2 Environmental.

Provide environmental specifications in accordance with UFC 3-810-01N.

16-5.3 eOMSI Facility Data Workbook.

Provide the source file (Excel format) of the eOMSI FDW in a separate file folder. Provide the PDF of the completed Model & Facility Data Matrix tab of the eOMSI FDW attached to UFGS 01 78 24.00 20.

16-6 CONTRACT SOLICITATION.

Provide a PIF, which includes the Bid Schedule as specified in Chapter 10, and a complete scope for use in the project Synopsis.

16-7 INTERIOR DESIGN.

16-7.1 Structural Interior Design (SID).

Include the following:

- Interior and Exterior Material and Finish samples submitted in presentation board or binder format.
- Signage plans, details, and schedules.
- FF&E Plan indicating built-in and movable items.
- FF&E Summary List corresponding to the FF&E Plan with estimated item costs.

16-7.2 FF&E.

Provide Preliminary FF&E to include the following, and present to the Activity and NAVFAC personnel:

- Cover Title Page (project name, project #, submittal date, submittal title).
- FF&E list (Cost Summary).
- Furniture placement plans coded to the FF&E list and furnishings specifications.
- Specifications and procurement data sheets (such as furniture, furnishings), indicating final finish and fabric selections.
- Catalog cuts and finish samples for each specified item.
- 16 x 20 inch (406 x 508 mm) color boards of furniture/furnishings and finishes specified for Activity presentation to indicate overall design intent.
- Best Value Determination (BVD) Analysis including copy of the BVD Analysis cover letter, performance specifications, project specific typical, pricing spreadsheet and questionnaire.

16-8 CALCULATIONS.

Provide calculations, updated from previous submittal, to substantiate design level and to reflect resolution of previous government review comments, and in accordance with the Core UFCs and Chapter 6. Provide design analysis that is 100% complete. In addition, provide the following:

16-8.1 Mechanical.

Submit calculations to support the plumbing and mechanical systems and the major equipment comprising those systems. Submittals must include, but not be limited to, cooling loads, heating loads, air balance, and outside air calculations. Update the

energy analysis, provided at the Design Development phase, with the equipment efficiencies scheduled on the drawings.

16-8.2 Electrical.

Provide updated and complete calculations required by Core UFCs and include photometric calculations for interior and exterior lighting.

16-9 STATEMENT OF SPECIAL INSPECTIONS.

Prepare special inspections specification UFGS 01 45 35 (DBB and DB). This specification contains the DOD process for implementing the special inspections, testing, and observations required in accordance with IBC Chapter 17 as modified by UFC 3-301-01 and the International Existing Building Code as modified by UFC 3-301-01. The generic Schedule of Special Inspections is maintained on the WBDG (<https://www.wbdg.org/dod/ufgs/ufgs-forms-graphics-tables>).

16-10 DRAFT DD FORM 1354.

Provide a Draft DD Form 1354 in accordance with UFC 1-300-08. A blank, editable form is available for download at <https://www.esd.whs.mil/portals/54/documents/dd/forms/dd/dd1354.pdf>.

Break out assets by construction categories, provided on the form, and by the Navy-specific “Category Codes for Military Real Property” found in FC 2-000-05N. Coordinate the identification of appropriate asset construction categories with the Government’s Real Property Accounting Officer. Include quantities and units of measure; however, cost breakdown is not required.

16-11 FACILITY RECOGNITION PLAQUE.

Design for and specify a professionally designed and manufactured recognition plaque commemorating the opening of the facility and recognizing the leadership participants of the project. Coordinate the building recognition plaque location(s) with the TPC plaque location(s) (where applicable). Provide design details for wall blocking to support the weight of hanging the plaque(s). If multiple facilities are in the project, design a plaque for each major facility. Indicate requirements of plaque on drawings and specify in UFGS 10 14 00.20. Include the following information:

- Facility Name
- Identify recognition applied to the facility or person for which the facility has been dedicated
- Date of occupancy (month/year)
- Sustainability TPC achieved (if applicable)
- Using Activity Commander/ Commanding Officer

- Base Commander/ Commanding Officer
- NAVFAC Component Commander/ Facility Engineering Component Commanding Officer
- Prime Contractor
- Architect/ Engineer (DOR)

16-12 DB RFP DEVELOPMENT.

Provide edited, red-lined RFP, showing deletions from and additions to the DB template and UFGSS. Follow Specifications requirements in Chapter 8 for prescriptive specifications provided in Part 5 of the RFP.

RFP submittal must be complete at this stage and require only minor corrections if any. Organize Part 2 specifications in accordance with Chapter 11.

16-13 OVERSEAS TRANSLATIONS.

Provide translated documents in accordance with the contract.

16-14 QUALITY CONTROL (QC) REVIEW AND DOCUMENTATION.

16-14.1 Review.

Provide a quality control review by a third party not involved in the design of the project. Evaluate both technical accuracy and discipline coordination. The QC review must include, but is not limited to, the following:

- Eliminate errors, omissions, interferences, and inconsistencies among design disciplines and among drawings, specifications, and cost estimates.
- Verify current criteria, lessons learned, and responses to approved review comments are incorporated.
- Ensure the constructability of the facility as detailed in the drawings, specifications, and technical documents.
- Ensure documents are biddable.

16-14.2 Documentation.

With the submittal, provide Design Quality Control (DQC) documentation that demonstrates that cross-checking of documents has taken place. Provide a single set of documents highlighted to validate that the review was performed, and that the corrections were made.

CHAPTER 17 PHASE: FINAL DESIGN SUBMITTALS

17-1 GENERAL REQUIREMENTS.

The Final Submittal provides a complete and final set of contract documents ready for bid solicitation by the Government, or in the case of DB, ready for construction by the Contractor. Previous government review comments must have been addressed.

Unless specified otherwise by the Contract, provide final submittals in electronic format in accordance with Chapter 12. Update deliverables from the previous submittal stages, and in addition to requirements from the Core UFCs, provide the following, as a minimum, for the Final Submittal:

17-2 BASIS OF DESIGN.

Submit final Basis of Design for each of the core disciplines, including updated information and incorporating responses to previous government review comments.

17-2.1 Geotechnical.

The Geotechnical DOR must validate that findings and design recommendations from the latest edition of the Geotechnical Report are valid, and construction and site preparation recommendations have been correctly incorporated into the pertinent drawings and specifications. Provide a verification letter from the Geotechnical DOR, signed and sealed, certifying that a review of the Final drawings and specifications, as they relate to the Geotechnical Report, has been conducted and that these drawings and specifications comply with the Geotechnical Report findings and recommendations.

17-3 SUSTAINABILITY.

Provide updated HPSB Checklist(s) for each applicable building in the project. Provide updated Sustainability Chapter. Provide updated TPC Checklist(s) (where applicable) for each applicable building in the project as a separate PDF.

17-3.1 TPC Design Review.

For projects that require TPC certification, submit TPC requirements for Design Review to TPC organization, no later than 60 days after Final Design Submittal.

17-4 DRAWINGS.

Provide complete construction drawings updated from the previous submittal level and organized by discipline in accordance with the Core UFCs and herein. Ensure NAVFAC drawing numbers are entered into the appropriate location on the NAVFAC standard drawing border within the native software format.

17-4.1 Plotstamp Record.

Provide a Plotstamp Record for each contract drawing. This history begins with the final design submittal and continues with subsequent submissions and modifications of that drawing. Maintain this record and make it available at the jobsite for review. Locate the Plotstamp Record on the lower left corner of the sheet, outside the border, and at the staple edge with the text rotated 90 degrees. Include the following:

- File Name: (Include the file location)
- Layout Name (if applicable)
- Plotted: Date and Time
- User: First name and last name of the person who printed the drawing

17-4.1.1 DB Plotstamp Records.

In addition, provide an updated Plotstamp Record at the following developmental stages of the contract drawings:

- a. DOR signed Final Critical Path Submittal or the Final Design Submittal.
- b. Government approved Final Critical Path Submittal or the Final Design Submittal. This development stage may be combined with "c." below, if issued at the same time.
- c. Incorporation of the Final Critical Path or Final Design drawings in the contract by modification.
- d. Submissions to Government and modifications of the Final Critical Path or Final Design drawings incorporating variations in the contract.

17-4.2 DB Shop Drawings.

For DB projects, follow the requirements of the RFP when shop drawings are used as design drawings.

17-5 BIM DESIGN MODEL.

Provide Clash Detection Report, Visual Review Report, and Final Design BIM Model in accordance with Chapter 12 and PxP. There must be zero clashes.

17-6 SPECIFICATIONS.

Provide complete, final specifications with redlines executed. Organize and compile the package as detailed in Chapter 8.

17-6.1 eOMSI Facility Data Workbook.

Provide complete Model & Facility Data Matrix tab of the eOMSI FDW and attach to UFGS 01 78 24.00 20. In addition, provide the native Excel file of the FDW with the electronic files.

17-6.2 Sustainability.

Attach final HPSB Checklist(s) and TPC Checklist(s) (where applicable) for each applicable building in the project to UFGS 01 33 29.

17-6.3 Environmental.

Comply with UFC 3-810-01N for environmental specifications.

17-6.4 DB Design Submittal Specifications.

For DB projects, follow the requirements of the RFP when manufacturer's catalog data are used with the UFGS during design.

17-6.4.1 Fire Protection Specifications.

For Fire Protection systems, combine design and construction submittal information on the design documents. In addition to the UFGS specification, provide proprietary information, such as catalog cuts and manufacturers data that demonstrates compliance with the RFP. Fire protection systems include fire suppression systems, fire pumps, fire alarm and detection systems, fire-stopping, and spray-applied fireproofing.

17-6.5 Report Source File.

As part of the Final submittal of the specifications, provide the source files of Reports included in the specifications.

17-7 CONTRACTING DOCUMENTS.

Provide a final, completed PIF, including Bid Schedule. Provide final scope for Project Synopsis.

17-8 INTERIOR DESIGN.

17-8.1 Structural Interior Design (SID).

Update deliverables for Interior Design from Pre-Final. Include Interior and Exterior Material and Finish samples submitted in presentation board or binder format.

17-8.2 FF&E.

Provide the final FF&E submittal with final submittal package. Present to NAVFAC and to the Activity. Update FF&E deliverables from Pre-Final.

- Cover Title Page (project name, project #, submittal date, submittal title)
- Table of Contents and Manufacturer Contact List
- FF&E list (Cost Summary)
- Furniture placement plans coded to the FF&E list and furnishings specifications
- Specifications and procurement data sheets, such as for furniture and furnishings, indicating final finish and fabric selections.
- Catalog cuts and finish samples for each specified item.
- 16x20 inch (406 x 508 mm) color boards of furniture/furnishings and finishes specified for Activity presentation to indicate overall design intent
- BVD Sheets signed by the Offeror's Interior Designer with required supporting information.

17-9 CALCULATIONS.

Revise design analysis and calculations as required to reflect resolution of previous government review comments and in accordance with this document and the core UFCs.

17-10 DRAFT FORM DD 1354.

Provide completed Draft Form DD 1354.

17-11 STATEMENT OF SPECIAL INSPECTIONS.

Prepare special inspections specification Section 01 45 35 (DBB and DB). This specification contains the DOD process for implementing the special inspections, testing, and observations required in accordance with IBC Chapter 17 as modified by UFC 3-301-01 and the International Existing Building Code as modified by UFC 3-301-01. The generic Schedule of Special Inspections is maintained on the WBDG (<https://www.wbdg.org/dod/ufgs/ufgs-forms-graphics-tables>).

17-12 RFP.

Provide complete, final RFP with redlines executed. Organize and compile the package as detailed in Chapter 11.

17-12.1 Report Source File.

As part of the Final submittal, provide source file of Reports included in the RFP, in either Word or SpecsIntact.

17-13 FIRE PROTECTION DESIGN COMPLIANCE DOCUMENT.

This design compliance document must be submitted with the final design submission as part of the design analysis and must bear the signature and professional seal of the QFPE. Refer to UFC 3-600-01.

17-14 QUALITY CONTROL (QC) REVIEW AND DOCUMENTATION.

17-14.1 Review.

Provide a quality control review by a third party not involved in the design of the project. Evaluate both technical accuracy and discipline coordination. The QC review must include, but is not limited to, the following:

- Eliminate errors, omissions, interferences, and inconsistencies among design disciplines and among drawings, specifications, and cost estimates.
- Verify current criteria, lessons learned, and responses to approved review comments are incorporated.
- Ensure the constructability of the facility as detailed in the drawings, specifications, and technical documents.
- Ensure documents are biddable.

17-14.2 Documentation.

With the submittal, provide Design Quality Control (DQC) documentation that demonstrates that cross-checking of documents has taken place. Provide a single set of documents highlighted to validate that the review was performed, and that the corrections were made. Provide a stamp on the cover page of the drawing set and specifications as shown in Figure 17-1.

Figure 17-1 Quality Review Block.

QUALITY CONTROL REVIEW	
Signature	Date

17-14.3 DB Quality Control.

For DB projects, this review must be a coordinated effort between the Contractor and their DOR. Additional Overseas Submittals Requirements.

17-14.4 Code Compliance Certification.

Design must comply with the applicable U.S. & Host Nation norms, regulations, and applicable U.S. Military criteria. Plans and Specifications must be certified by a Host Nation architect or engineer, registered on the country's professional rolls, for compliance with applicable codes and laws.

Provide this certification on the cover sheet of project drawings and specifications, in dual languages. If the specifications coversheet does not have sufficient space for this certification, provide directly behind the coversheet on a separate page, including the project information from the coversheet. The code compliance certification must be provided as indicated in Figure 17-2 below, and dated, signed, and stamped in accordance with the requirements set forth in Chapter 7 of this document.

Figure 17-2 Code Compliance Certification

HAVING PARTICIPATED IN THE DESIGN OF PROJECT No. (Identify project number, project title, location), AND HAVING THOROUGHLY REVIEWED THE COMPLETED PROJECT DOCUMENTS, I DECLARE THAT THE FACILITY DESIGN INCLUDED HEREIN COMPLIES WITH ALL APPLICABLE (Identify Host Country) CODES AND LAWS.		
Date	Signature	(Professional Seal)
<hr/>		

17-14.5 Host Nation Life Safety/Building Code Compliance Documentation.

Provide the following in accordance with UFC 3-600-01:

- Host Nation Life Safety and Building Code analysis.
- Comparisons of Host Nation requirements with NFPA Codes, UFC 1-200-01, and UFC 1-200-02
- Items of conflict and approved resolutions
- Additional costs, both engineering effort to prepare the design modification and estimated construction costs

17-14.6 Geotechnical Report Translation.

Translate the Geotechnical Report into English. Unless stated otherwise in the contract, the boring logs must be shown in two languages, English and the local language of country of bidding and construction.

This Page Intentionally Left Blank

CHAPTER 18 PHASE: POST-DESIGN OR POST-RFP DEVELOPMENT SUBMITTAL REQUIREMENTS

18-1 GENERAL REQUIREMENTS.

Submissions after final design or RFP development must integrate changes resulting from Contractor Pre-Proposal Inquiries (PPI) and Requests for Information (RFI) into Amendment and Contract Modification documents. Submissions may include additions or corrections to drawings, specifications, or RFP, and an explanation of changes. Changes to the Contract Documents before contract award are Amendments; changes after contract award are Contract Modifications.

18-2 PRE-PROPOSAL AND REQUESTS FOR INFORMATION.

Responses to PPIs and RFIs must be responded to as quickly as possible to prevent delay to construction contract award. It is expected that the DOR will provide response to a PPI or RFI no later than three working days after notification. Where the response to a PPI or RFI requires additional time, the DOR must notify the Government Project Manager/Design Manager or Contracting Officer of the expected date of response. The DOR must indicate if an Amendment or a Contract Modification is required in response to the PPI or RFI.

18-3 CHANGE NUMBERS OR LETTERS.

Prior to submission, the Contracting Officer for the procurement/contract assigns the Amendment number or Contract Modification letter and provides to the PM and DM. Numbers or letters are assigned in numerical order as required. Amendment numbers are prefixed by three ciphers, for example, the first Amendment is numbered "0001".

18-4 COST ESTIMATE CHANGES.

Accompany Amendment or Contract Modification with detailed cost estimates to indicate changes in construction cost of the project, or to substantiate a statement of no change in cost. Accompany Contract Modification with a detailed cost estimate that can be used in the negotiation of Contract Modification.

18-5 CHANGE FORMAT.

The Contracting Officer prepares the Standard Form SF 30, *Amendment of Solicitation/Modification of Contract*, coversheet for an Amendment. Block 14 of this form is the "Description of Amendment" with enough space for a brief description, thus, the first page of the changes text starts on page two called the Continuation Sheet with an explanation of the changes. Submit the Continuation Sheet to the Contracting Officer for processing.

Provide a Proposed Change Sheet for a Contract Modification with an explanation of the changes. Include the Modification letter, contract number, and task order number (if

available), eProjects work order number, project title, and project location. Submit the Proposed Change Sheet to the Contracting Officer for processing.

Where drawings, RFP sections, or specifications are replaced or added, attach the document PDF file separately, and reference in the Continuation Sheet or Proposed Change Sheet in accordance with guidance below. When multiple drawing, RFP section, or specification files are replaced or added, combine the documents by type into a single file, and bookmark each document. Follow file size limitations in accordance with Chapter 12.

18-5.1 Continuation Sheet, Modification, and Language Format.

Use Figure 18-1 Sample Amendment/Modification for guidance on how to format the language for revisions and changes. List specification changes, additions, deletions, or replacement of complete specification sections only under the specifications PROJECT TABLE OF CONTENTS. For drawing changes, additions, deletions, or replacements of a complete drawing must be listed in specification 00 01 15 LIST OF DRAWINGS and on the DRAWING INDEX sheet.

When drawings are revised and replaced, use a cloud to highlight the change. For Amendments, place a triangle with a sequential number in it and place it next to the cloud or the item(s) changing for each sheet. For Modifications, use a triangle with a sequential letter. Provide the number or the letter on the sheet revision block and provide the same brief over-arching description on the revised sheets. Insert the date that the change was made; this distinguishes the revised drawing from the original drawing. Also, note that a sheet has been added or replaced in the DRAWING INDEX sheet. Do not change sheet numbers or sheet designations for revised drawings. Listing the Amendment or Contract Modification number is not appropriate.

Best Practices:

Minimize narrative only description of changes on Continuation Sheets. Recommend reissuing the sheet(s) or specification section(s).

Maximize practice of indicating changes by issuing replacement Drawings and Specification Sections. NOTE: Previous narrative only changes must be incorporated.

Apply above guidance as much as practicable, without significant slow-down in communications with bidders or impacts to pre-award execution.

Figure 18-1 Sample Amendment/Modification

[CONTINUATION SHEET] [MODIFICATION “modification letter”]

DRAWINGS:

On NAVFAC Drawing No. [NAVFAC DWG No.] (G-101)

ADD the following drawings to the DRAWING INDEX under the corresponding discipline and drawing number. These drawings accompany this [Amendment] [Modification]:

S-213 [NAVFAC DWG No.] BRACED BAY FRAMING ELEVATIONS - ADDED SHEET
M-504 [NAVFAC DWG No.] DETAILS – ADDED SHEET

REPLACE the following drawings to the DRAWING INDEX under the corresponding discipline and drawing number. These drawings accompany this [Amendment] [Modification]:

A-301 [NAVFAC DWG No.] ELEVATIONS – REPLACED SHEET
P-503 [NAVFAC DWG No.] DETAILS – REPLACED SHEET

On NAVFAC Drawing No. [NAVFAC DWG No.] (CS510)

A5/CS510 Detail: **DELETE** “9’-10”” vertical dimension and **REPLACE** with “10’-0””.

On NAVFAC Drawing No. [NAVFAC DWG No.] (S-101)

Foundation Plan Notes: Note 3, **DELETE** “THE BOTTOM OF THE FOOTING” and **REPLACE** with “THE TOP OF THE FOOTING”.

On NAVFAC Drawing No. [NAVFAC DWG No.] (A-505)

B5/A-505 Breakroom Elevation, **DELETE** note “PNT4” and **REPLACE** with “PNT5”.

SPECIFICATIONS:

PROJECT TABLE OF CONTENTS

ADD the following section(s) that accompany this [Amendment] [Modification]. Add date in the footer to distinguish the added section.*

01 45 35 Special Inspections, dated May 17, 2023
09 29 00 Gypsum Board, dated May 17, 2023

REPLACE the following section(s) with the attached section(s) that accompany this [Amendment] [Modification]. Add date in the footer to distinguish the replaced section.*

07 11 13 Bituminous Dampproofing, dated May 17, 2023
09 68 00 CARPETING, dated May 17, 2023

(*NOTE to specification editor: To change the date, for subsequent additions/replacements of the section, a date must be manually typed into the footer on the ‘Print Processing > Header/Footer’ tab in SpecsIntact. See the eLearning Module in Chapter 4: Process and Print/Publish, Header/Footer Tab.)

DOCUMENT 00 01 15 LIST OF DRAWINGS

1.2 Contract Drawings

ADD the following drawings. These drawings accompany this [Amendment] [Modification].

<u>DRAWING</u> <u>NO.</u>	<u>REVISION</u> <u>NO.</u>	<u>NAVFAC</u> <u>DWG NO.</u>	<u>TITLE</u>
S-213	1	[*****]	BRACED BAY FRAMING ELEVATIONS
M-504	1	[*****]	DETAILS

DELETE and **REPLACE** the following drawings as of [date]. These drawings accompany this [Amendment] [Modification].

<u>DRAWING</u> <u>NO.</u>	<u>REVISION</u> <u>NO.</u>	<u>NAVFAC</u> <u>DWG NO.</u>	<u>TITLE</u>
CU102	1	[*****]	SITE UTILITY PLAN
LP102	1	[*****]	LANDSCAPE PLANTING PLAN

SECTION 01 50 00 TEMPORARY CONSTRUCTION FACILITIES AND CONTROLS

1.4 Construction Site Plan

DELETE this paragraph and **REPLACE** with: “Prior to the start of work, submit a site plan showing the locations and dimensions of temporary facilities (including layouts and details, equipment and material storage area (onsite and offsite), and access and haul routes, avenues of ingress/egress to the fenced area and details of the fence installation.”

SECTION 03 30 00 CAST-IN-PLACE CONCRETE

1.3 Submittals, SD-02 Shop Drawings

ADD “Survey Plan; G”.

ADD subpart “1.6.3.5 Survey Meeting

Coordinate a meeting with surveyor, QC Manager, field superintendent, concrete subcontractor, and Contracting Officer to discuss a plan to survey the formwork and the embedded components prior to concrete placement. Discuss the schedule, coordination issues, timing, and efficiency issues.”

--End of [Amendment] [Modification]—

CHAPTER 19 PHASE: POST-CONSTRUCTION DOCUMENTS

19-1 PROJECT CLOSE-OUT.

The DOR may be required to execute specific project tasks during project close-out. These tasks may include preparing DD Form 1354, "Real Property Record," for Government signature, attending project close-out meetings, or performing other tasks. Refer to the design contract (if a DBB project) or the DB RFP for project close-out related tasks.

19-1.1 Interim Form DD 1354.

Update the Draft DD Form 1354 to include additional assets, improvements or alterations that occurred during construction. Identify costs. Submit completed form for approval to the Government. Attach to each DD Form 1354, updated HPSB Checklist(s) and TPC Checklist(s) for each applicable building in the project. For these DD Form 1354, ensure Block 14, "Sustainability Code" is marked with "1" for compliant.

19-1.2 Record Drawings.

Prepare record drawings in accordance with Chapter 12.

19-1.3 BIM Final Record Model.

Provide the final Record Model in accordance with Chapter 12.

19-1.4 Sustainability.

No later than 60 days after Beneficial Occupancy Date, provide updated HPSB Checklist(s) for each applicable building in the project to the Government Project Manager. Obtain TPC for each applicable building in the project when TPC organization requirements are complete. For projects with post-occupancy sustainability or energy requirements (such as commissioning), provide updated HPSB Checklist to the Government Project Manager. Ensure copies of the following are archived to the project's electronic sustainability folder:

- Copy of the Final Commissioning Report, and copy of the Updated Final Commissioning Report, when applicable, for projects that use Government-hired Commissioning Provider.
- Copy of the Final report, validation, or certification for projects that apply Sustainable TPC.
- Contractor's completed submittal of the Sustainability eNotebook, and the Updated Sustainability eNotebook when applicable.

This Page Intentionally Left Blank

APPENDIX A SAMPLE DELIVERABLES

A-1 PRICE SCHEDULE FORM FOR DBB PROJECT

Price Schedule Form is located at: <https://www.wbdg.org/navy/project-information-form-specifications-cover-sheet/spec-coversheet>

Line Item	Description	Quantity	Unit	Unit Price	Sub-Total	Total Price
1	BASE PRICE: Total Price for the entire work for [Project P### – Insert description of the project scope here] in accordance with the [drawings and specifications][RFP], complete, but excluding work provided in another Priced line Item.	1	EA			\$_____
1A	Subtotal of Base Price for the entire work for [Insert Primary Facilities Description] complete to the [1.5-meter] [5-foot] line outside of the building in accordance with the [drawings and specifications][RFP], but excluding work provided in another line item	1	EA		\$_____	
1B	Subtotal of Base Price for the entire project sitework, outside the facility [1.5-meter][5-foot] line, for [Insert Site Work Description here], complete in accordance with the [drawings and specifications][RFP], but excluding work described in another line Item.	1	EA		\$_____	
1C	Subtotal of Base Price for entire Design of the Project, complete, but excluding work provided in another line item.	1	EA		\$_____	
1D	Unit Price for providing Foundation Piling complete in accordance with the [drawings and specifications][RFP], but excluding work provided in another line item.	[_____]	[LM] [LF]	\$_____	\$_____	

1E	Unit Price for providing Pile Load Test, complete in accordance with the [drawings and specifications][RFP], but excluding work provided in another line item.	[_____]	EA	\$_____	\$_____	
1F	Unit Price for mass rock excavation and disposal complete in accordance with the [drawings and specifications][RFP], but excluding work provided in another line item.	[_____]	[CM] [CY]	\$_____	\$_____	
1G	Unit Price for trench rock excavation and disposal complete in accordance with the [drawings and specifications][RFP], but excluding work provided in another line item.	[_____]	[CM] [CY]	\$_____	\$_____	
1H	Unit Price for removal and disposal of asbestos containing pipe insulation (by pipe diameter ranges [_____]) complete in accordance with the [drawings and specifications][RFP], but excluding work provided in another line item.	[_____]	[LM] [LF]	\$_____	\$_____	
1J	Unit Price for removal and disposal of asbestos containing floor tile complete in accordance with the [drawings and specifications][RFP], but excluding work provided in another line item.	[_____]	[SM] [SF]	\$_____	\$_____	
1K	Unit Price for removal and disposal of asbestos containing siding complete in accordance with the [drawings and specifications][RFP], but excluding work provided in another line item.	[_____]	[SM] [SF]	\$_____	\$_____	
1L	Unit Price for providing removal and disposal of oily water and sludge inside tanks [_____], complete in accordance with the [drawings and specifications][RFP], but excluding work provided in another line item.	[_____]	[L] [Gal]	\$_____	\$_____	

1M	Unit Price for removal and disposal of contaminate stockpiled soils complete in accordance with the [drawings and specifications][RFP], but excluding work provided in another line item.	[_____]	[CM] [CY]	\$_____	\$_____	
1N	Unit Price for provision and compaction of fill in place of removed contaminate soil, complete in accordance with the [drawings and specifications][RFP], but excluding work provided in another line item.	[_____]	[CM] [CY]	\$_____	\$_____	
2	Option Item No. 1: Price for providing all work in connection with [_____], complete in accordance with the [drawings and specifications][RFP], but excluding work provided in another Priced line item.	1	EA			\$_____
3	Option Item No. 2: Price for providing Electronic Security System (ESS) equipment, testing, and associated training, but excluding work provided in another Priced line item. The ESS includes, but is not limited to, Intrusion Detection System (IDS), Access Control System (ACS), and Video Systems complete in accordance with the [drawings and specifications] [RFP]. Equipment includes items such as Premise Control Units (PCU), central processing units, field panels, sensors, card readers, keypads, cameras, switches, video recorders, workstations, and the communication cabling connecting these devices together. Include the price for supporting, permanent infrastructure under the Base Price. Interior supporting infrastructure includes items such	1	EA			\$_____

	as conduit, junction boxes, electronic door strikes, door-hardware, mounting hardware, and power connections. Exterior supporting infrastructure includes items such as exterior duct banks, manholes, utility poles, utility connections, and power connections.					
4	<p>Option Item No. 3: Price for providing Audio Visual System (A/V) Equipment, testing, and associated training in accordance with the [drawings and specifications] [RFP], but excluding work provided in another Priced line item.. Equipment includes, but is not limited to, items such as flat panel monitors, projectors, wall input boxes, touch screens, push button control panels, video teleconferencing codecs, microphones, speakers and the communication cabling connecting these devices together.</p> <p>Include the price for supporting, permanent infrastructure under the Base Price. Interior supporting infrastructure includes items such as conduit, junction boxes, mounting hardware, and power connections.</p>	1	EA			\$_____
5	Option Item No. 4: Price for providing work in connection with labor, material, equipment, transportation and supervision required for the Furniture, Fixtures, and Equipment (FF&E), complete in accordance with the [drawings and specifications][RFP], but excluding work provided in another Priced line item.	<p>GOV Estimated Price:</p> <p>[\$_____]</p>	<p>HAR Percent (NTE 5%)</p> <p>____%</p>		<p>HAR Subtotal</p> <p>\$_____</p>	<p>Total FF&E Estimated Price</p> <p>\$_____</p>

A-2 SAMPLE SYNOPSIS

Synopsis for P236 FITNESS CENTER, CLDJ

THIS NOTICE IS PROVIDED FOR INFORMATION PURPOSES ONLY. THIS PROCUREMENT WILL BE SOLICITED ON AN UNRESTRICTED BASIS. SOLICITATION DOCUMENTS WILL NOT BE AVAILABLE FOR DOWNLOADING UNTIL APPROXIMATELY 17 DECEMBER 2012.

This is a one step design/bid/build construction project that will construct a two-story fitness center at Camp Lemonnier, Djibouti (CLDJ), Africa. The building is a pre-engineered metal building on reinforced concrete slab and foundations with insulated metal wall and roof panels, translucent wall panels, hydraulic elevator, interior concrete partitions, metal stud and gypsum board partitions, interior finishes, fire alarm and sprinkler system, plumbing, mechanical, electrical and incidental related work. Scope requirements include site preparation necessary for the construction of the fitness center also requiring installation of 75 new Containerized Living Units (CLUs), relocation of 75 existing CLUs encumbering the site, and replacing the artificial turf on the existing athletic field. Once the 75 new CLUs are constructed then the occupants of G-Block CLUs can relocate thus allowing those CLUs to be moved, triple stacked, and retrofitted with fire alarm and sprinkler systems.

Other scope requirements include the demolition of the existing fitness center after the new facility is constructed.

The period of performance is approximately 18 months after notice to proceed.

This project will be awarded as a firm-fixed price contract. The Government reserves the right to enter into negotiations or limit the competitive range. The construction range is between \$10,000,000 and \$25,000,000.

This contract will require a Performance Bond pursuant to FAR 52.228-15, through an approved surety under the United States Treasury Department Circular 570. Based on the feasibility of a contractor to furnish a Performance Bond, offerors may provide a 10% Performance Guarantee, in accordance with NFAS 5252.228-9306, in lieu of a Performance Bond.

The Request for Proposals (RFP) will be available for viewing and downloading on or about 17 December 2012. The proposal due date will be on or about January 31, 2013, 2:00 p.m. Eastern Standard Time North America.

The solicitation will be formatted as an RFP in accordance with the requirements designated by Federal Acquisition Regulation (FAR) 15.203 for a negotiated procurement utilizing procedures of FAR 36.2. This method permits evaluation of proposals based on price competition, technical merit and other factors; permits impartial and comprehensive evaluation of offerors' proposals; permits discussions if necessary; and ensures selection of the source whose performance provides the best value to the Government.

This Page Intentionally Left Blank

APPENDIX B COST ESTIMATE CLASSIFICATION AND VALUE ENGINEERING STUDY REQUIREMENTS

B-1 INDUSTRY COST ESTIMATE CLASSIFICATION.

AACE International publishes Recommended Practice 56R-08, *Cost Estimate System – As Applied for the Building and General Construction Industries*. This recommended practice (RP) defines the relationship between the maturity of the construction project definition deliverables and the accuracy of the cost estimate based on those deliverables. The RP defines five classes of estimates based on the level of project definition maturity. These five levels overlap to account for factors of the project such as project complexity and quality of cost data.

AACE International RP 56R-08 applies to the majority of projects undertaken by NAVFAC. In the cases where a project is similar to projects from the process industry, AACE International RP 17R-97 would be acceptable as a guidance to estimate accuracy classification. It is similar in its definition of estimate maturity but does not include a table that is analogous to Table 3 from AACE RP 56R-08.

Table B-1 Cost Estimate Class Comparison from AACE RP 56-08.²

Table 3 Estimate Input Checklist and Maturity Matrix from AACE International RP 56R-08 Copyright © 2020 by AACE International; all rights reserved	ESTIMATE CLASSIFICATION				
	Class 5	Class 4	Class 3	Class 2	Class 1
MATURITY LEVEL OF PROJECT DEFINITION DELIVERABLES	0% to 2%	1% to 15%	10% to 40%	30% to 75%	65% to 100%
GENERAL PROJECT DATA:					
A. SCOPE:					
Project Scope of Work Description	P	P	D	D	D
Site Infrastructure (such as Access, Construction Power, Camp)	NR	P	D	D	D
B. CAPACITY:					
Functional Space – SF or m2	P	P	D	D	D
Electrical Power Requirements (when not the primary capacity driver)	NR	P	D	D	D
Mechanical Systems	NR	P	D	D	D
C. PROJECT LOCATION:					
Building and Other Project Elements	P	P	D	D	D
D. REQUIREMENTS:					

² Reprinted with the permission of AACE International, 1265 Suncrest Towne Center Dr., Morgantown, WV 26505 USA. Phone 304-296-8444. Internet: <https://web.aacei.org/> Email: info@aacei.org Copyright © 2020 by AACE International; all rights reserved

Table 3 Estimate Input Checklist and Maturity Matrix from AACE International RP 56R-08 Copyright © 2020 by AACE International; all rights reserved	ESTIMATE CLASSIFICATION				
	Class 5	Class 4	Class 3	Class 2	Class 1
MATURITY LEVEL OF PROJECT DEFINITION DELIVERABLES	0% to 2%	1% to 15%	10% to 40%	30% to 75%	65% to 100%
Anti-Terrorism Force Protection	P	D	D	D	D
No. of Building Floors	P	P/D	D	D	D
Security System	NR/P	P	D	D	D
Sustainability Requirements (and TPC Level where applicable)	NR/P	P/D	D	D	D
Codes and Standards	NR	P	D	D	D
Communication Systems	NR	P	D	D	D
Exterior Closure Description	NR	P	D	D	D
Finishes Descriptions	NR	P	D	D	D
Fire Protection and Life Safety	NR	P	D	D	D
Environmental Monitoring	NR	NR	P	P	D
E. TECHNOLOGY SELECTION:					
N/A					
F. STRATEGY:					
Contracting/Sourcing	NR	P	D	D	D
Escalation	NR	P	D	D	D
G. PLANNING:					
Logistics Plan	P	P	P	D	D
Integrated Project Plan	NR	P	D	D	D
Project Code of Accounts	NR	P	D	D	D
Project Master Schedule	NR	P	D	D	D
Regulatory Approval & Permitting	NR	P	D	D	D
Risk Register	NR	P	D	D	D
Stakeholder Consultation /Engagement / Management Plan	NR	P	D	D	D
Work Breakdown Structure	NR	P	D	D	D
Startup and Commissioning Plan	NR	P	P/D	D	D
Storm Water Management Plan	NR	P	P/D	D	D
H. STUDIES:					
Environmental Impact / Sustainability Assessment	NR	P	D	D	D
Environmental Existing Conditions	NR	P	D	D	D
Soils and Hydrology	NR	P	D	D	D
TECHNICAL DELIVERABLES					
Site Plan	S	P	C	C	C
Design Specifications	NR	S/P	C	C	C
Electrical One-line Drawings	NR	S/P	C	C	C

Table 3 Estimate Input Checklist and Maturity Matrix from AACE International RP 56R-08

Copyright © 2020 by AACE International; all rights reserved

	ESTIMATE CLASSIFICATION				
	Class 5	Class 4	Class 3	Class 2	Class 1
MATURITY LEVEL OF PROJECT DEFINITION DELIVERABLES	0% to 2%	1% to 15%	10% to 40%	30% to 75%	65% to 100%
General Equipment Arrangement Drawings	NR	S/P	C	C	C
Plot Plans / Facility Layouts	NR	S/P	C	C	C
Room Classification Data Sheet	NR	S/P	C	C	C
Room Layout Drawings	NR	S/P	C	C	C
Construction Permits	NR	S/P	P/C	C	C
Building Plan Views, Sections and Elevations	NR	S/P	P	C	C
Civil / Site / Structural / Architectural Discipline Drawings	NR	S/P	P	C	C
Codes and Standards Drawings	NR	S/P	P	C	C
Demolition Plan and Drawings	NR	S/P	P	C	C
Erosion Control Plan and Drawings	NR	S/P	P	C	C
Exterior Elevations	NR	S/P	P	C	C
Finish Schedule	NR	S/P	P	C	C
Fire Protection and Life Safety Drawings and Details	NR	S/P	P	C	C
Furniture Plans, Schedules and Drawings	NR	S/P	P	C	C
Interior Section Views	NR	S/P	P	C	C
Landscape Drawings	NR	S/P	P	C	C
Plumbing Drawings	NR	S/P	P	C	C
Roof Plan, Drawings and Details	NR	S/P	P	C	C
Storm Water Drawings	NR	S/P	P	C	C
Window Schedules	NR	S/P	P	P/C	C
Door Schedules	NR	S/P	P	C	C
Restroom Schedules	NR	S/P	P	C	C
Signage Drawings and Schedules	NR	S/P	P	C	C
Partition or Wall Types	NR	S/P	S/P	C	C
Electrical Schedules	NR	NR/S	P	P/C	C
Equipment Datasheets	NR	NR/S	P	P/C	C
Equipment Lists: Electrical	NR	NR/S	P	P/C	C
Equipment Lists: Process / Utility / Mechanical	NR	NR/S	P	P/C	C
Instrument and Control Schedules	NR	NR/S	P	P/C	C
Instrument Datasheets	NR	NR/S	P	P/C	C
Piping Schedules	NR	NR/S	P	P/C	C

Table 3 Estimate Input Checklist and Maturity Matrix from AACE International RP 56R-08
Copyright © 2020 by AACE International; all rights reserved

	ESTIMATE CLASSIFICATION				
	Class 5	Class 4	Class 3	Class 2	Class 1
MATURITY LEVEL OF PROJECT DEFINITION DELIVERABLES	0% to 2%	1% to 15%	10% to 40%	30% to 75%	65% to 100%
Piping Discipline Drawings	NR	NR/S	S/P	C	C
Spare Parts Listings	NR	NR	P	P/C	C
Electrical Discipline Drawings	NR	NR	S/P	P/C	C
Facility Emergency Communications Plan and Drawings	NR	NR	S/P	P/C	C
HVAC Drawings	NR	NR	S/P	P/C	C
Information Systems / Telecommunications Drawings	NR	NR	S/P	P/C	C
Mechanical Discipline Drawings	NR	NR	S/P	P/C	C
Room Discipline Drawings	NR	NR	S/P	P/C	C
Interior Lighting Plan and Drawings	NR	NR	S/P	P	C
Lighting Control Diagram	NR	NR	S/P	P	C
Lighting Schedules	NR	NR	S/P	P	C
Lightning Protection Drawings	NR	NR	S/P	P	C
Mechanical / HVAC Schedules	NR	NR	S/P	P	C
Motor Control Diagram	NR	NR	S/P	P	C
Plumbing Details	NR	NR	S/P	P	C
Security Plan and Drawings	NR	NR	S/P	P	C
Instrument List	NR	NR	S	P/C	C
Building Envelope / Moisture Protection / Flashing Details	NR	NR	S	P	C
Interior Elevations	NR	NR	S	P	C

Degree of Completion Descriptors

General Project Data:

- **Not Required (NR):** May not be required for all estimates of the specified class, but specific project estimates may require at least preliminary development.
- **Preliminary (P):** Project definition has begun and progressed to at least an intermediate level of completion.
- **Defined (D):** Project definition is advanced, and reviews have been conducted. Development may be near completion with the exception of final approvals.

Technical Deliverables:

- **Not Required (NR):** Deliverable may not be required for all estimates of the specified class, but specific project estimates may require at least preliminary development.
- **Started (S):** Work on the deliverable has begun. Development is typically limited to sketches, rough outlines, or similar levels of early completion
- **Preliminary (P):** Work on the deliverable is advanced. Interim, cross-functional reviews have usually been conducted. Development may be near completion except for final reviews and approvals.
- **Complete (C):** The deliverable has been reviewed and approved as appropriate.

B-2 PRELIMINARY DESIGN COST ESTIMATE.

For Preliminary Design scope development, the project definition is based on the minimum project data and deliverables indicated in Table B-2.

Table B-2 Minimum Project Data and Deliverables.

Crosswalk between AACE International RP56R-08 and Preliminary Design	<u>Preliminary Design</u>	<u>Remarks</u>
Maturity level of project definition deliverables	Preliminary Design Deliverables	
General Project Data		
Construction Scope Description	Defined	DD1391 requirements govern this.
Project Location	Defined	DD1391 requirements govern this.
Total Building Area - SF or m2	Defined	DD1391 requirements govern this.
Functional Space Requirements -SF or m2	Defined	DD1391 requirements govern this.
No. of Building Stories	Defined	DD1391 requirements govern this.
Exterior Closure Description	Preliminary	Addressed in the Basis of Design.
Finishes Descriptions and Requirements	Preliminary	
Building Code or Standards Requirement	Defined	
Mechanical Systems and Total Capacity	Preliminary	
Electrical Capacity	Defined	
Communication Systems	Preliminary	
Fire Protection and Life Safety Requirements	Preliminary	
Security System	Started	
Antiterrorism	Defined	

Crosswalk between AACE International RP56R-08 and Preliminary Design	<u>Preliminary Design</u>	<u>Remarks</u>
Sustainability	Started	Sustainability – Indicate the feasibility of meeting Guiding Principle requirements and other sustainability goals for the project in accordance with UFC 1-200-02. Include a draft High Performance Sustainable Building (HPSB) Checklist. Where TPC is an anticipated requirement, develop a draft TPC checklist.
Soils and Hydrology Report	Started	Utilize existing topographic/hydrographic data to the maximum extent possible.
Integrated Project Plan	Preliminary	Other preliminary design deliverables that may not always be supported by the Project Technical Team.
Project Master Schedule	Preliminary	
Work Breakdown Structure	Preliminary	
Project Code of Accounts	None	
Contracting Strategy	Preliminary	Identify DBB or DB costs for considering the application of SIOH to the design effort relative to representing the information on the DD1391.
Escalation Strategy and Basis	Discussed	Include escalation calculations in the Basis of Estimate.
Design Deliverables [3]	RP 56R-08 uses: None [blank]; Started [S]; Preliminary [P]; Complete [C].	
Building Codes and Standards Drawing	None	Separate document not required
Fire Protection and Life Safety Requirements	P	Address requirements in the basis of design.
Site Plan	P	Preliminary design drawing or sketch - Site Plan(s): Show the layout (size and possible shape) of the new facility in relation to major landmarks. Show the possible location of access roads, parking, landscaping, pedestrian walkways, roads, and sidewalks, as applicable. Indicate approximate dimensions and orientation. Site Plans must clearly indicate site constraints such as explosive safety arcs, flood zones, wetlands or other environmentally sensitive areas. Where AT is applicable, clearly depict setback distances to vulnerabilities, including parking, roadways, and obstructions.

Crosswalk between AACE International RP56R-08 and Preliminary Design	<u>Preliminary Design</u>	<u>Remarks</u>
Existing Site Plan	P	Preliminary design drawing or sketch - Vicinity Map and Location Plan
Demolition Plan and Drawings	P	Preliminary design drawing or sketch - Demolition Plan: Show facilities to be demolished (if required)
Utility Plan and Drawings	P	Preliminary design drawing or sketch - Utilities Plans: Show utility lines and their points of connection in relation to existing adjacent structures, roads, and utilities. Show off-site utility upgrade requirements needed to support the project. Show civil, electrical and telecommunication utilities to clearly convey the scope and quantities associated with various utility improvements. On large utility distribution projects, provide one-line diagrams of electrical and telecommunication utilities.
Site Electrical Plan and Drawings	P	
Site Lighting Plan and Drawings	P	
Site Communication Plan and Drawings	P	
Erosion Control Plan and Drawings	S/P	Address requirements in the basis of design - Basis of design for site and utility related disciplines (for example, civil, electrical, telecommunication) must identify the design assumptions for Supporting Facilities, as required to support quantities and unit costs for Supporting Facilities. Consult with landscape architecture personnel for select projects, where a large proportion of total cost is likely to be associated with landscaping requirements.
Stormwater Plan and Drawings	S/P	
Landscaping Plan and Drawings	S/P	
Exterior Elevations	P	Preliminary design drawing or sketch - Building Elevations: Provide schematic elevations indicating the building exterior character.
Interior Elevations	No drawing, plan, diagram or schedule	Address requirements in the Basis of Design - Basis of design for building systems (for example, architecture, structural, mechanical, electrical, fire protection) must identify the discipline-specific design assumptions, as required to support a parametric estimate on the Primary Facility. Consult with interior design personnel for select projects, where unique interior design requirements cannot be captured by standard parametric estimating techniques for the facility-type.
Interior Section Views		
Partition or Wall Types		
Finish Schedule		
Door Schedules		
Window Schedules		
Restroom Schedules		
Furniture Plans, Schedules and Drawings		
Signage Drawings and Schedules		
Fire Protection Plan, Drawings and Details		

Crosswalk between AACE International RP56R-08 and Preliminary Design	<u>Preliminary Design</u>	<u>Remarks</u>
Room Layout Plan and Drawings	P	Preliminary design drawing or sketch - Building Floor Plans: Provide schematic floor plans depicting functional utilization of spaces. For renovation projects, provide separate drawings where required to identify existing conditions, demolition, and new construction elements.
Foundation Plan and Drawings	No drawing, plan, diagram or schedule	<p>Address requirements in the Basis of Design - Basis of design for building systems (for example, architecture, structural, mechanical, electrical, fire protection) must identify the discipline-specific design assumptions, as required to support a parametric estimate on the Primary Facility.</p> <p>Basis of design for FRCS must indicate the Cybersecurity Impact Level for the control system. \1\ For work in existing buildings, include identification and documentation of existing FRCS infrastructure and how the new work is integrated. /1/ Provide discussion, where the cybersecurity accreditation process or requirements are expected to significantly impact project cost or schedule.</p>
Foundation Sections and Details		
Structural Plans and Drawings		
Structural Sections and Drawings		
Roof Plan, Drawings and Details		
Material, Equipment and System Specifications		
Building Envelope/moisture protection/flashing details		
Mechanical/HVAC Plan and Drawings		
Mechanical HVAC/Details		
Mechanical HVAC/Schedules		
Flow Control Diagrams		
Plumbing Plan and Drawings		
Plumbing Details		
Plumbing Riser Diagram		
One-Line Electrical Diagram		
Electrical Power Plan		
Interior Lighting Plan and Drawings		
Security Plan and Drawings		
Emergency Communication Plan and Drawings		
Life Safety Plan and Drawings		
Lightning Protection Plan and Drawings		
Motor Control Diagram		
Lighting Control Diagram		
Lighting Schedules		
Electrical Control/Panel Schedule		
Equipment Schedule		
Information Systems/Telecommunication Plan		
Information Systems/Telecommunication Details		

B-3 VALUE ENGINEERING STUDY (VES) REQUIREMENTS.

Provide the service of a Value Engineering (VE)/Value Analysis (VA) team led by a Value Study Team Leader (VSTL) to conduct a Value Engineering Study (VES) to include a Value Engineering Workshop (VEW). The VEW may be combined with other meetings or workshops associated with the project. The VES must follow the methodology advocated by SAVE International and will be documented in a report. Each of the alternatives evaluated as part of the VES must be achievable with the project's construction award amount.

The following industry standards apply to the extent feasible in accordance with the level of design development:

- SAVE Value Methodology Guide, 2020
- ASTM E1699 *Standard Practice for Value Engineering (VE)/Value Analysis (VA) of Projects, Products, and Processes* (Latest Revision)
- ASTM E2013 *Standard Practice for Constructing FAST Diagrams and Performing Function Analysis During Value Analysis Study* (Latest Revision)

B-3.1 VE/VA Team Requirements.

Value Study Team Leader (VSTL): Provide a VSTL certified by SAVE International as a Certified Value Specialist, with experience in preparing Value Studies and conducting VES workshops for projects related to the construction of buildings and other engineered systems. The VSTL will be responsible for leading the VE/VA team, resolving issues to the maximum extent possible, documenting meetings, organizing the study materials for on-site use/approval, and providing the VES Report.

DOR PDT will provide the VE/VA Technical Team.

B-3.2 VES Kick Off Meeting.

Conduct the VES meeting via teleconference and review workshop preparations, scope, expectations, roles and responsibilities, schedules, and documentation requirements. This meeting will generally last one hour and must be attended by the VSTL and the Project Manager (PM) and Design Manager (DM) from the DOR.

B-3.3 Value Engineering Workshop (VEW).

The VEW must be attended by the VSTL as well as the key members of the DOR's PDT. This is to include the DOR's PM, DM, Architect, Structural Engineer, Mechanical Engineer, Electrical Engineer, Civil Engineer, Landscape Architect, Cost Engineer, Fire Protection Engineer, Interior Designer, CTS-D, Geotechnical Engineer, and Sustainability Coordinator. Other technical disciplines may be included if approved by the NAVFAC PM, DM, or Cost TDC. The VSTL will lead the VEW following the six-step job plan consistent with the SAVE International Value Standard, ASTM E1699 and

ASTM E2013. A comprehensive VEW will establish the six steps during the on-site workshop. An abbreviated VEW will accomplish the first three steps during the workshop and the remaining three steps after the workshop. The six phases of the Value Methodology Job Plan are:

1. Information Phase
2. Function Analysis Phase (including FAST Diagrams in accordance with ASTM E2013)
3. Creative Phase
4. Evaluation Phase
5. Development Phase
6. Presentation Phase

B-3.3.1 VEW Preparations.

Provide a meeting facility to accommodate the anticipated number of participants. The facility is to provide access to photocopying for handout material and access to the Internet for Email and research by participants.

Complete the following items prior to the start of the VEW:

- a. As a minimum, review the available documentation gathered by the NAVFAC PDT. This includes but is not limited to:
 - Information included or cited in the project's scope of services (SAES or SIHS as appropriate)
 - Design Instructions from other agencies
 - Design authorization and programming documents
 - Studies, cost estimates, and other information
- b. \1\ Plan and coordinate for a site visit prior to the workshop to allow the VSTL and the VE/VA Technical Team to become familiar with the project site. Coordinate this effort with the NAVFAC PM/DM. /1/
- c. \1\ The VSTL is to prepare a sample presentation format for the use of the DOR's VE/VA Technical Team. Submit a copy of this for NAVFAC review and approval. /1/
- d. Prepare a presentation handout \1\ for VEW participants. Submit this handout for NAVFAC review and approval. This handout is to include: /1/
 - A discussion of the overall VES methodology

- A discussion of the scope of work as currently developed
- A discussion of the current program amount allocated for the project
- A discussion of the current estimated construction cost estimate
- A capital cost model as indicated in ASTM E1699, 7.2.8 \1\ /1/.
- A discussion of the project documentation provided for this study, noting that copies are available during the workshop
- A discussion of the performance and acceptance requirements for evaluating alternatives in accordance with ASTM E1699, 7.2.5 \1\ /1/.

B-3.3.2 VEW Process.

- a. The DOR's PDT members will explain how the current scope/design accomplishes the stakeholder objectives.
- b. The workshop participants will generate a list of ideas for project improvement followed by an evaluation of those ideas. The evaluation will include input from key stakeholder decision makers before proceeding with development recommendations.
- c. The VE/VA Technical Team will develop selected ideas into alternatives with enough documentation to allow decision makers to determine if the alternative should be implemented.
- d. The VSTL, with input from NAVFAC, will evaluate each alternative in accordance with the pre-determined performance and acceptance requirements.
- e. The VSTL will present the alternatives to the key stakeholder decision makers on the final day of the workshop.

B-4 VES DECISION/IMPLEMENTATION MEETING.

The VSTL must conduct a four hour Decision/Implementation Meeting via teleconference. This meeting is to assist key project stakeholders in the selection of which of the developed alternatives to implement. The VES Decision/Implementation Meeting must be attended by the DOR's PDT who will be working on this project. This is to include the DOR's PM, DM, Architect, Structural Engineer, Mechanical Engineer, Electrical Engineer, Civil Engineer, Landscape Architect, Cost Engineer, Fire Protection Engineer, Interior Designer, CTS-D, and Geotechnical Engineer. Other technical disciplines may be included if approved by the NAVFAC PM, DM, or Cost TDC.

B-5 VES REPORT.

Provide a report documenting the VES process and its application to this project by capturing the process and the alternatives considered or recommended. Provide a report reflecting the type of VEW performed, comprehensive or abbreviated.

Include the following in the report:

- Project Objectives
- Project Description
- Scope Analysis
- VES Procedure
- VES Alternatives and associated savings/improvements considered
- VES Alternatives and associated savings/improvements recommended
- Copy of the original Study Team Presentation Handout

B-5.1.1 Comprehensive Workshop VES Report.

- a. Preliminary VES Report: Include a collection of the findings of six phases of the Value Methodology Job Plan at the conclusion of the workshop.
- b. Draft Final VES Report: Incorporate revisions from previous submittal comments and include a list of final recommendations.
- c. Final VES Report: Incorporate revisions from previous submittal comments and the implementation decisions captured during the Decision/Implementation Meeting.

B-5.1.2 Abbreviated Workshop VES Report.

- a. Preliminary VES Report: Include a collection of draft/summaries of the findings at the conclusion of the workshop. As a minimum address the first (3) phases of the Value Methodology Job Plan covered during the workshop.
- b. Interim VES Report: Include revisions of the Preliminary VES Report and include draft/summaries of the last (3) phases of the Value Methodology Job Plan.
- c. Draft Final VES Report: Incorporate revisions from previous submittal comments and include a list of final recommendations
- d. Final VES Report: Incorporate revisions from previous submittal comments and the implementation decisions captured during the Decision/Implementation Meeting.

APPENDIX C BIM (MODELING)

C-1 BIM - BASIS OF DESIGN SAMPLE TABLES.

Examples to assist with completion of the Basis of Design are provided in the following Tables. Modify the text to suit the needs of the organization filling out the template.

Table C-1 Key Project Contacts

ROLE	ORGANIZATION	NAME	EMAIL	PHONE
DOR Project Manager	[NAVFAC / AGENT]	[John/Jane Doe]		
NAVFAC Project Manager	[NAVFAC]			
DOR BIM Manager	[Company]			
DOR Architectural Lead	[Company]			
NAVFAC Architectural Lead	[NAVFAC]			
DOR Structural Lead	[Company]			
NAVFAC Structural Lead	[NAVFAC]			
DOR Interiors Lead	[Company]			
NAVFAC Interiors Lead	[NAVFAC]			
DOR Landscape Architecture Lead	[Company]			
NAVFAC Landscape Architecture Lead	[NAVFAC]			
DOR Civil Lead	[Company]			
NAVFAC Civil Lead	[NAVFAC]			
DOR Fire Protection Lead	[Company]			
NAVFAC Fire Protection Lead	[NAVFAC]			
DOR Mechanical Lead	[Company]			

ROLE	ORGANIZATION	NAME	EMAIL	PHONE
NAVFAC Mechanical Lead	[NAVFAC]			
DOR Electrical/Telecom Lead	[Company]			
NAVFAC Electrical/Telecom Lead	[NAVFAC]			
DOR Plumbing Lead	[Company]			
NAVFAC Plumbing Lead	[NAVFAC]			
NAVFAC Design Manager	[NAVFAC]			
NAVFAC Construction Manager	[NAVFAC]			
DOR Sustainability Coordinator	[Company]			
NAVFAC Sustainability Coordinator	[NAVFAC]			
Other Project Roles	[Company]			

Table C-2 Major BIM Goals and Objectives

BIM GOAL	DESCRIPTION
Models	3D Parametric Design Model and Record Model
Design Facility Data	DOR Edited Model & Facility Data Matrix tab from eOMSI Facility Data Workbook (FDW)

Table C-3 BIM Uses

The BIM Uses currently checked with an (X) are mandatory and required by NAVFAC.

DESIGN	
X	DESIGN FACILITY DATA
X	DESIGN MODELING
X	CLASH DETECTION (3D COORDINATION)

Table C-4 Organizational Roles and Staffing

ROLES / STAFFING			
PROCESS	ORGANIZATION	LOCATION(S)	LEAD CONTACT
DESIGN FACILITY DATA	[DOR]		
DESIGN MODELING	[DOR]		
PROGRESS REVIEWS	NAVFAC		
CLASH DETECTION (3D COORDINATION)	[DOR]		

C-2 QUALITY CONTROL CHECKS.

C-2.1 Overall Strategy for Quality Control.

Describe the strategy to control the quality of the model.

C-2.2 Quality Control Checks.

The following checks are required to assure quality. Provide Responsible Party name and title.

Table C-5 Quality Control Checks

REVIEW	DEFINITION	RESPONSIBLE PARTY	SOFTWARE PROGRAM(S)	FREQUENCY
VISUAL REVIEW	Check the DOR Edited Model & Facility Data Matrix tab from the eOMSI Facility Data Workbook against the design intent, so that there are no unintended elements or omissions in the Design Model	John Doe Architect		AT EVERY SUBMITTAL
CLASH DETECTION (3D COORDINATION)	Detect problems in the model where two building components intersect (for example, a structural beam intersects HVAC duct work)			AT EVERY SUBMITTAL

APPENDIX D GLOSSARY

D-1

ACRONYMS.

A-E	Architect and Engineer
A/E/C	A/E/C CAD Standard
V\ /1/	
BOD	Basis of Design
BPA	Budget Project Readiness Index (PRI) Authority
BRACON	Base Realignment and Closure Office
CAD	Computer Aided Design and Drafting
CATEX	Categorical Exclusion
V\ /1/	
CFA	Commission of Fine Arts
CMC	Commandant, Marine Corps
CRB	Consistency Review Board
CSI	Construction Specifications Institute TM
CONUS	Continental United States
CLIN	Contract Line Item Number
CSRA	Cost and Schedule Risk Analysis
DB	Design-Build
DBB	Design-Bid-Build
DFPE	Designated Fire Protection Engineer
DIGGS	Data Interchange for Geotechnical and Geoenvironmental Specialists
DoD	Department of Defense
DOR	Designer of Record
DQC	Design Quality Control

V\ /1/

EA	Environmental Assessment
EBS	Electronic Bid Solicitation
EDD	Electronic Design Deliverables
EIS	Environmental Impact Statement
eOMSI FDW	Electronic Operation and Maintenance Support Information (eOMSI) Facility Data Workbook
FACD	Facility Analysis Concept Design
FACP	Fire Alarm Control Panel
FC	Facility Criteria
FF&E	Furniture, Fixtures, and Equipment
FOSSAC	Fitting Out and Supply Support Assistance Center
HAR	Handling and Administration Rate
HPSB	High Performance and Sustainable Buildings
IFP	Installation Focus Plan
IP	Inch-Pound (English)
KTR	Contractor
LCC	Life-Cycle Cost
LID	Low Impact Development
MCON	Military Construction Navy
MILCON	Military Construction
MOU	Memorandum of Understanding
NAC	Notification Appliance Circuit
NAVFAC	Naval Facilities Engineering Systems Command
NCPC	National Capitol Planning Commission
NEHC	Naval Environmental Health Center

NEPA	National Environmental Policy Act
NFPA	National Fire Protection Agency
NIST	National Institute of Science and Technology
NIWC	Naval Information Warfare Center
NLIDDC	NAVFAC Low Impact Development Data Card
NOSSA	Naval Ordnance Safety and Security Activity (NOSSA)
OSHA	Occupational Safety and Health Administration
OCONUS	Outside the Continental United States
PBI	Pre-Bid Inquiry
PCAS	Post-Construction Award Services
PDA	Preliminary Design Authority
PDF	Portable Document File
PIF	Project Information Form
PM	Project Manager
PPI	Pre-Proposal Inquiry
PRI	Project Readiness Index
PROD	Permit Record of Design
PWD	Public Works Department
PTS	Performance Technical Specification
PxP	Project Execution Plan
QFPE	Qualified Fire Protection Engineer
RAC	Risk Assessment Code
RAMP	Requirements and Management Plan
RFI	Request For Information
RFP	Request For Proposal

RONA	Record of Non-Applicability
SAES	Statement of A-E Services
SAPF	Special Access Program Facility
SCIF	Sensitive Compartmented Information Facilities
SHPO	State Historic Preservation Officer
SI	System International (Metric)
TDC	Technical Discipline Coordinator
TPC	Third-Party Certification
UFC	Unified Facilities Criteria
UFGS	Unified Facilities Guide Specifications
VES	Value Engineering Study

APPENDIX E REFERENCES

E-1 GOVERNMENT

FEDERAL GOVERNMENT

36 CFR 800, *Protection of Historic Properties*, <https://www.ecfr.gov/current/title-36/chapter-VIII/part-800>

DEPARTMENT OF DEFENSE

DFARS 227.71, *Technical Data and Associated Rights*,
<https://www.acq.osd.mil/dpap/dars/dfarspgi/current/index.html>

DFARS 227.72, *Computer Software, Computer Software Documentation, and Associated Rights* <https://www.acq.osd.mil/dpap/dars/dfarspgi/current/index.html>

DFARS 252.227-7023, *Drawings and Other Data to Become Property of Government*,
<https://www.acq.osd.mil/dpap/dars/dfarspgi/current/index.html>

DoD Directive 4270.5, *Military Construction*, 12 February 2005,
<https://www.esd.whs.mil/Portals/54/Documents/DD/issuances/dodd/427005p.pdf?ver=2018-11-08-080607-280>

DoD Instruction 5200.48, *Controlled Unclassified Information (CUI)*, 6 March 2020,
<https://www.esd.whs.mil/Portals/54/Documents/DD/issuances/dodi/520048p.PDF>

MIL-STD-3007, *Standard Practice for Unified Facilities Criteria, Facilities Criteria and Unified Guide Specifications*, <https://www.wbdg.org/dod/fedmil/mil-std-3007>

Public Law 94-168, *Metric Conversion Act*,
<https://www.govinfo.gov/content/pkg/STATUTE-89/pdf/STATUTE-89-Pg1007.pdf>

Public Law 106-229, *Electronic Signatures in Global and National Commerce Act*,
<https://www.govinfo.gov/content/pkg/PLAW-106publ229/pdf/PLAW-106publ229.pdf>

UNIFIED FACILITIES CRITERIA (UFC / FC)

<https://www.wbdg.org/dod/ufc>

FC 4-721-10N, *Navy and Marine Corps Unaccompanied Housing*

UFC 1-200-01, *DoD Building Code*

UFC 1-200-02 *High Performance and Sustainable Building Requirements*

UFC 1-300-02, *Unified Facilities Guide Specifications (UFGS) Format Standard*

UFC 1-300-08, *Criteria for Transfer and Acceptance of DoD Real Property*

UFC 3-101-01, *Architecture*

UFC 3-201-02, *Landscape Architecture*

UFC 3-210-10, *Low Impact Development*

UFC 3-220-01, *Geotechnical Engineering*

UFC 3-250-01, *Pavement Design for Roads and Parking Areas*

UFC 3-260-02, *Pavement Design for Airfields*

UFC 3-260-03, *O&M Manual: Standard Practice for Airfield Pavement Evaluation*

UFC 3-301-01, *Structural Engineering*

UFC 3-340-01, *Design and Analysis of Hardened Structures to Conventional Weapons Effects (FOUO)*

UFC 3-410-01, *Heating, Ventilating, and Air Conditioning Systems*

UFC 3-420-01, *Plumbing Systems*

UFC 3-501-01, *Electrical Engineering*

UFC 3-600-01, *Fire Protection Engineering for Facilities*

UFC 3-701-01, *DoD Facilities Pricing Guide*

UFC 3-730-01, *Programming Cost Estimates for Military Construction*

UFC 3-740-05, *Construction Cost Estimating*

UFC 3-810-01N, *Navy and Marine Corps Environmental Engineering for Facility Construction*

UFC 4-010-01, *DoD Minimum Antiterrorism Standards for Buildings*

UFC 4-010-05, *SCIF/ SAPF Planning, Design, and Construction*

UFC 4-010-06, *Cybersecurity of Facility-Related Control Systems*

UFC 4-023-03, *Design of Buildings to Resist Progressive Collapse*

UFC 4-510-01, *Design: Medical Military Facilities*

UFC 4-610-01, *Administrative Facilities*

UFC 4-722-01, *Design: Dining Facilities*

UFC 4-740-02, *Fitness Centers*

UNIFIED FACILITIES GUIDE SPECIFICATIONS (UFGS)

<https://www.wbdg.org/dod/ufgs> (unless otherwise noted)

UFGS 00 01 15, *List of Drawing*

UFGS 01 11 00, *Summary of Work*

UFGS 01 33 00, *Submittal Procedures*

UFGS 01 33 00.05 20, *Construction Submittal Procedures*,
https://www.wbdg.org/FFC/NAVFAC/NDBM/UFGS/01_33_00.05_20.pdf

UFGS 01 33 10.05 20, *Design Submittal Procedures*,
https://www.wbdg.org/FFC/NAVFAC/NDBM/UFGS/01_33_10.05_20.pdf

UFGS 01 33 29, *Sustainability Requirements and Reporting*

UFGS 01 45 00, *Quality Control*

UFGS 01 45 35, *Special Inspections*

UFGS 01 78 23, *Operation and Maintenance Data*

UFGS 01 78 24.00 20, *Facility Data Workbook (FDW)*

UFGS 02 82 00, *Asbestos Remediation*

UFGS 10 14 00.20, *Interior Signage*

UFGS 33 40 00, *Stormwater Utilities*

UNITED STATES ARMY

DoD A/E/C CAD Standard, <https://cadbimcenter.erdcdren.mil/aeccadstandard>

UNITED STATES NAVY

V1\1/

Naval Facilities Acquisition Standards, (NFAS), Part 6.304, *Competition Requirements, Other Than Full and Open Competition, Approval of the justification*,
https://www.navfac.navy.mil/Portals/68/Documents/Business-Lines/Office-of-Small-Business/Opportunities/Contracting%20Guidelines/Contracting%20with%20NAVFA/C/sb_navfac_naval_facilities_acq_standard_oct_2018_change1_aug2019.pdf?ver=tqB6mpXivX_Q1pTxGnPcg%3D%3D

FC 2-000-05N, *Facility Planning for Navy and Marine Corps Shore Installations*

NAVFAC Design-Build Master RFP website, <https://www.wbdg.org/navy/ndbm>

1\Programming Administration and Execution (PAX), Naval Facilities Engineering Systems Command. Contact government administrator for intranet address and access./1/

1\SECNAV Instruction (SECNAVINST) 3070.2A, *Operations Security*, 09 May 2019, <https://www.secnav.navy.mil/doni/Directives/03000%20Naval%20Operations%20and%20Readiness/03-00%20General%20Operations%20and%20Readiness%20Support/3070.2A.pdf/1/>

GENERAL SERVICES ADMINISTRATION (GSA)

<https://www.acquisition.gov/browse/index/far>

FAR 52.217-5, *Evaluation of Options*

FAR 52.236-21, *Specifications and Drawings for Construction*

FAR 52.236-25, Requirements for Registration of Designers

Standard Form (SF) 30, *Amendment of Solicitation/ Modification of Contract*, <https://www.gsa.gov/reference/forms/amendment-of-solicitationmodification-of-contract>

GOVERNMENT ACCOUNTABILITY OFFICE (GAO)

<https://www.gao.gov/>

GAO-16-89G, *Schedule Assessment Guide*

E-2 NON-GOVERNMENT

AACE INTERNATIONAL (AACE)

<https://web.aacei.org/>

Recommended Practice 27R-03, *Schedule Classification System*

Recommended Practice 56R-08, *Cost Estimate Classification System – As Applied in Engineering, Procurement, and Construction for the Building and General Construction Industries*

AMERICAN SOCIETY OF HEATING, REFRIGERATION AND AIR CONDITIONING ENGINEERS (ASHRAE)

<https://www.ashrae.org/>

ANSI/ASHRAE Standard 62.1, *Ventilation and Acceptable Indoor Air Quality*

ANSI/ASHRAE Standard 62.2, *Ventilation and Acceptable Indoor Air Quality in Residential Buildings*

ASHRAE 90.1, *Energy Standard for Buildings Except Low-Rise Residential Buildings*

ASTM

<https://www.astm.org/>

ASTM D1452, *Standard Practice for Soil Exploration and Sampling by Auger Borings*

ASTM D1586, *Standard Test Method for Standard Penetration Test (SPT) and Split-Barrel Sampling of Soils*

ASTM D2487, *Standard Practice for Classification of Soils for Engineering Purposes (Unified Soil Classification System)*

ASTM D2488, *Standard Practice for Description and Identification of Soils (Visual-Manual Procedures)*

ASTM D3740, *Standard Practice for Minimum Requirements for Agencies Engaged in Testing and/or Inspection of Soil and Rock as Used in Engineering Design and Construction*

ASTM D5778, *Standard Test Method for Electronic Friction Cone and Piezocone Penetration Testing of Soils*

ASTM E1699, *Standard Practice for Performing Value Engineering (VE)/Value Analysis (VA) of Projects, Products and Processes*

ASTM E1804, *Standard Practice for Performing and Reporting Cost Analysis During the Design Phase of a Project*

ASTM E 2013, *Standard Practice for Developing Functions, Constructing FAST Diagrams, and Performing Function Analysis During Value Engineering (VE)/Value Analysis (VA) Study*

CONSTRUCTION SPECIFICATIONS INSTITUTE (CSI)

MasterFormat®, <https://www.csiresources.org/standards/masterformat>

UniFormat®, <https://www.csiresources.org/standards/uniformat>

FM GLOBAL

<https://www.fmglobal.com/>

Property Loss Prevention Data Sheet 3-0, *Hydraulics of Fire Protection Systems*

INTERNATIONAL CODE COUNCIL (ICC)

<https://www.iccsafe.org/>

IBC, *International Building Code (IBC)*

IEBC, *International Existing Building Code (IEBC)*

NATIONAL FIRE PROTECTION ASSOCIATION (NFPA)

<https://www.nfpa.org/>

NFPA13, *Standard for the Installation of Sprinkler Systems*

NFPA 72, *National Fire Alarm and Signaling Code*

NFPA 101, *Life Safety Code*

NFPA 291, *Recommended Practice for Fire Flow Testing and Marking of Hydrants*

NATIONAL SOCIETY OF PROFESSIONAL SURVEYORS (NSPS)

Model Standards for Topographic Surveys,

<https://www.nsp.us.com/page/ModelStandards>

SAVE INTERNATIONAL

<https://www.value-eng.org/>

SAVE *Value Methodology Guide*, 2020

UNITED STATES NATIONAL CAD STANDARD

United States National CAD Standard (NCS) for Architecture, Engineering, & Construction <http://www.nationalcadstandard.org/>

WHOLE BUILDING DESIGN GUIDE (WBDG)

<https://www.wbdg.org/>

eOMSI FDW, *Electronic Operation and Maintenance Support Information (eOMSI), Facility Data Workbook*, <https://www.wbdg.org/navy/bim-eomsi>