

# UNIFIED FACILITIES CRITERIA (UFC)

---

## DESIGN: MILITARY MEDICAL FACILITIES



APPROVED FOR PUBLIC RELEASE; DISTRIBUTION UNLIMITED

**UNIFIED FACILITIES CRITERIA (UFC)**

**DESIGN: MILITARY MEDICAL FACILITIES**

Any copyrighted material included in this UFC is identified at its point of use. Use of the copyrighted material apart from this UFC must have the permission of the copyright holder.

Indicate the preparing activity beside the Service responsible for preparing the document.

DEFENSE HEALTH AGENCY / FACILITIES ENTERPRISE

U.S. ARMY CORPS OF ENGINEERS

NAVAL FACILITIES ENGINEERING COMMAND (Preparing Activity)

AIR FORCE CIVIL ENGINEER CENTER

Record of Changes (changes are indicated by \1\ ... /1/)

Change No.	Date	Location

## FOREWORD

The Unified Facilities Criteria (UFC) system is prescribed by MIL-STD 3007 and provides planning, design, construction, sustainment, restoration, and modernization criteria, and applies to the Military Departments, the Defense Agencies, and the DoD Field Activities in accordance with [USD \(AT&L\) Memorandum](#) dated 29 May 2002. UFC will be used for all DoD projects and work for other customers where appropriate. All construction outside of the United States is also governed by Status of Forces Agreements (SOFA), Host Nation Funded Construction Agreements (HNFA), and in some instances, Bilateral Infrastructure Agreements (BIA). Therefore, the acquisition team must ensure compliance with the most stringent of the UFC, the SOFA, the HNFA, and the BIA, as applicable.

UFC are living documents and will be periodically reviewed, updated, and made available to users as part of the Services' responsibility for providing technical criteria for military construction. Headquarters, U.S. Army Corps of Engineers (HQUSACE), Naval Facilities Engineering Command (NAVFAC), and Air Force Civil Engineer Center (AFCEC) are responsible for administration of the UFC system. Defense agencies should contact the preparing service for document interpretation and improvements. Technical content of UFC is the responsibility of the cognizant DoD working group. Recommended changes with supporting rationale should be sent to the respective service proponent office by the following electronic form: [Criteria Change Request](#). The form is also accessible from the Internet sites listed below.

UFC are effective upon issuance and are distributed only in electronic media from the following source:

- Whole Building Design Guide web site <http://dod.wbdg.org/>.

Refer to UFC 1-200-01, *DoD Building Code (General Building Requirements)*, for implementation of new issuances on projects.

### AUTHORIZED BY:



---

LARRY D. McCALLISTER, PhD, PE,  
PMP, SES  
Chief, Engineering and Construction  
U.S. Army Corps of Engineers



---

JOSEPH E. GOTT, P.E.  
Chief Engineer  
Naval Facilities Engineering Command

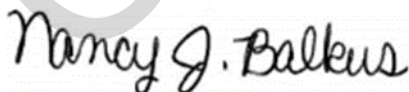

---

NANCY J. BALKUS, PE, SES, DAF  
Deputy Director of Civil Engineers  
DCS/Logistics, Engineering &  
Force Protection



---

MICHAEL McANDREW  
Deputy Assistant Secretary of Defense  
(Facilities Investment and Management)  
Office of the Assistant Secretary of Defense  
(Energy, Installations, and Environment)

## UNIFIED FACILITIES CRITERIA (UFC) REVISION SUMMARY SHEET

**Document:** UFC 4-510-01, Design: Military Medical Facilities

**Superseding:** UFC 4-510-01, Design: Military Medical Facilities, 1 May 2016 with Change 2, November 2017

**Description:** This UFC 4-510-01 provides mandatory policies and procedures for programming, planning, design, and construction throughout the lifecycle of Military Medical Facilities, also referenced as Medical Treatment Facilities.

**Reasons for Document:** The existing guidance has been updated to current practices and standards. This revision of UFC 4-510-01 contains modifications in the following areas:

- Updated with major code revisions (NFPA 70, 99, 101, etc.)
- Updated to include lessons learned from current projects
- Coordination with Core UFCs and formatting to align with UFC 1-300-01
- Updated to align with recent changes to UFC 3-600-01
- Eliminated planning and programming processes that do not directly impact design and construction
- Updated veterinary requirements including finishes and utility requirements

### Impact:

- The impact of these revisions to include close coordination with other mandatory criteria and codes, allows for more standardization thus minimizing errors in our criteria from programming to construction. The information herein, prescribes the most efficient and effective means to lower design costs, improve energy savings, and thus attaining the most cost effective life cycle costs.

### Unification Issues

- Army and Air Force have their own Interior Design Guidelines that are required for their projects.
- Navy Military Medical Facilities prefer the use of vinyl composition tile. Other components prefer the use of rubber flooring.
- Navy Military Medical Facilities permit lower STC ratings for some spaces specifically indicated in Appendix B.

TABLE OF CONTENTS

<b>CHAPTER 1 INTRODUCTION .....</b>	<b>1</b>
<b>1-1 PURPOSE AND SCOPE.....</b>	<b>1</b>
<b>1-2 APPLICABILITY.....</b>	<b>1</b>
<b>1-3 GENERAL BUILDING REQUIREMENTS. ....</b>	<b>1</b>
<b>1-4 CYBERSECURITY. ....</b>	<b>1</b>
<b>1-5 POLICY. ....</b>	<b>2</b>
<b>1-6 FLEXIBILITY. ....</b>	<b>2</b>
<b>1-7 RESPONSIBILITIES.....</b>	<b>3</b>
1-7.1 Defense Health Agency/Facilities Enterprise .....	3
1-7.2 Using Agency.....	3
1-7.3 Design and Construction Agents. ....	3
<b>1-8 WAIVERS OR EXEMPTIONS TO THIS DOCUMENT.....</b>	<b>5</b>
<b>1-9 GLOSSARY.....</b>	<b>5</b>
<b>1-10 REFERENCES. ....</b>	<b>5</b>
<b>CHAPTER 2 PREDESIGN .....</b>	<b>7</b>
<b>2-1 GENERAL. ....</b>	<b>7</b>
<b>2-2 PREDESIGN PROJECT DOCUMENTATION. ....</b>	<b>7</b>
2-2.1 Documents Prior to DA. ....	7
2-2.2 Program For Design (PFD) and Project Room Contents (PRC). ....	7
2-2.3 Existing Facilities Surveys. ....	7
2-2.4 Site Information.....	7
2-2.5 National Environmental Policy Act (NEPA) Documentation.....	8
2-2.6 Force Protection/Security Requirements. ....	8
2-2.7 Mission Essential Facilities and Related Requirements.....	9
2-2.8 Contingency Mode CONOPS (where applicable). ....	9
2-2.9 Fire Protection Considerations.....	9
2-2.10 Communications. ....	9
2-2.11 Commissioning. ....	9
2-2.12 Parking Requirement Calculation. ....	10
2-2.13 Addition-Alteration Facility Information. ....	10
2-2.14 Safety Risk Assessment (SRA) .....	10
<b>2-3 SCOPE AND COST CONSIDERATIONS. ....</b>	<b>10</b>

2-3.1	Improvement/Alteration/Additions .....	10
2-3.2	Site Investigation. ....	11
2-3.3	Interstitial Building System (IBS).....	11
2-3.4	Parking Facilities.....	11
2-3.5	Future Expansion.....	12
2-3.6	Special Environmental Conditions. ....	12
2-3.7	Emergency Electrical Supply. ....	12
2-3.8	Antiterrorism/Force Protection (AT/FP).....	12
2-3.9	Demolition of Vacated Facilities.....	12
2-3.10	Sustainability Considerations.....	12
2-3.11	Special Studies. ....	13
<b>CHAPTER 3</b>	<b>DESIGN .....</b>	<b>15</b>
<b>3-1</b>	<b>GENERAL .....</b>	<b>15</b>
<b>3-2</b>	<b>DESIGN CODES AND CRITERIA.....</b>	<b>15</b>
<b>3-3</b>	<b>DESIGN PARAMETERS.....</b>	<b>15</b>
3-3.1	Scope and Cost. ....	15
3-3.2	Gross Building Area Calculation. ....	16
3-3.3	Departmental Building Area Calculation. ....	16
3-3.4	Design to Cost. ....	26
<b>3-4</b>	<b>DESIGN SEQUENCE AND RESPONSIBILITIES.....</b>	<b>26</b>
3-4.1	Title 10 U.S.C. Section 2807 Action.....	26
3-4.2	Design Authorization (DA). ....	26
3-4.3	Authorization to Advertise Construction.....	26
3-4.4	Authorization to Award Construction.....	27
<b>3-5</b>	<b>REVIEW OF DESIGN DELIVERABLES, ROLES AND RESPONSIBILITIES .....</b>	<b>27</b>
3-5.1	Design and Construction Agent. ....	27
3-5.2	Installation Manager. ....	27
3-5.3	Using Agency.....	27
3-5.4	DHA/FE.....	27
<b>3-6</b>	<b>REPORTING REQUIREMENTS.....</b>	<b>28</b>
<b>3-7</b>	<b>DESIGN CONSIDERATIONS.....</b>	<b>28</b>
3-7.1	General.....	28

3-7.2	World-Class Checklist.....	29
3-7.3	Concepts of Operation (CONOPS).....	29
3-7.4	Parking.....	30
3-7.5	Future Expansion.....	30
3-7.6	Alterations and Additions to Existing Facilities.....	30
3-7.7	Safety Risk Assessment.....	31
3-7.8	NFPA 99 Risk Assessment.....	31
<b>3-8</b>	<b>DESIGN SUBMITTALS AND DOCUMENTATION REQUIREMENTS....</b>	<b>31</b>
<b>3-9</b>	<b>PROJECT COST ESTIMATES. ....</b>	<b>31</b>
<b>3-10</b>	<b>FUNDS MANAGEMENT POLICY. ....</b>	<b>31</b>
3-10.1	Title 10 U.S.C. Section 2853 Action.....	31
3-10.2	Return of Excess Funds.....	32
<b>3-11</b>	<b>HISTORICAL ANALYSIS GENERATOR (HAG) DATA.....</b>	<b>32</b>
<b>CHAPTER 4</b>	<b>SUSTAINABLE DESIGN PRINCIPLES .....</b>	<b>33</b>
<b>4-1</b>	<b>GENERAL. ....</b>	<b>33</b>
<b>4-2</b>	<b>DESIGN PROCESS.....</b>	<b>33</b>
<b>4-3</b>	<b>SUPPORTING DOCUMENTS.....</b>	<b>33</b>
<b>CHAPTER 5</b>	<b>ANTITERRORISM (AT) AND PHYSICAL SECURITY .....</b>	<b>35</b>
<b>5-1</b>	<b>GENERAL. ....</b>	<b>35</b>
<b>5-2</b>	<b>ADDITIONAL CRITERIA.....</b>	<b>35</b>
<b>5-3</b>	<b>DESIGN CRITERIA PLANNING TEAM. ....</b>	<b>35</b>
<b>5-4</b>	<b>ELECTRONIC SECURITY SYSTEMS (ESS).....</b>	<b>35</b>
5-4.1	Purpose.....	35
5-4.2	Systems Considerations.....	35
5-4.3	ESS Components and Funding Restrictions.....	36
5-4.4	System Configuration and Major Functional Components.....	37
5-4.5	ESS Network.....	38
5-4.6	Intrusion Detection and Duress Alarm.....	39
5-4.7	Door Access Control.....	40
5-4.8	ESS: Video Surveillance System (VSS).....	42
5-4.9	ESS: Infant Protection Alarm System (IPAS).....	43
5-4.10	ESS: Behavioral Health Staff Assist (BHSA) Alarm.....	44
5-4.11	Basic Design Requirements.....	44

<b>5-5</b>	<b>SPECIAL CONSIDERATIONS FOR SECURITY SENSITIVE AREAS AND ROOMS.....</b>	<b>45</b>
5-5.1	Safes.....	45
5-5.2	Vaults.....	45
5-5.3	Pharmacies.....	45
5-5.4	Medical Supply Storage Areas or Facilities.....	46
5-5.5	Other Security Sensitive Areas and Rooms.....	46
<b>CHAPTER 6</b>	<b>ARCHITECTURAL .....</b>	<b>47</b>
<b>6-1</b>	<b>GENERAL.....</b>	<b>47</b>
<b>6-2</b>	<b>EXTERNAL DESIGN.....</b>	<b>47</b>
<b>6-3</b>	<b>EXTERIOR WALL DESIGN.....</b>	<b>47</b>
<b>6-4</b>	<b>FENESTRATION AND WINDOWS.....</b>	<b>47</b>
<b>6-5</b>	<b>INTERIOR CONSTRUCTION.....</b>	<b>47</b>
6-5.1	Aseptic Environments.....	47
6-5.2	Interior Design.....	48
<b>6-6</b>	<b>FRONT DESK LOCATION.....</b>	<b>48</b>
<b>6-7</b>	<b>FLOORS.....</b>	<b>49</b>
<b>6-8</b>	<b>WALL AND PARTITION SYSTEMS.....</b>	<b>49</b>
6-8.2	Barriers.....	50
6-8.3	Protection and Safety Features.....	50
6-8.4	Toilet Facilities.....	50
6-8.5	Toilet Partitions.....	50
<b>6-9</b>	<b>CEILINGS.....</b>	<b>50</b>
6-9.1	Support.....	50
6-9.2	Utility Access.....	51
<b>6-10</b>	<b>VESTIBULES.....</b>	<b>51</b>
<b>6-11</b>	<b>DOORS.....</b>	<b>51</b>
6-11.1	Automatic Doors.....	51
6-11.2	Doors, Frames, and Hardware.....	51
<b>6-12</b>	<b>SUSTAINABLE DESIGN.....</b>	<b>51</b>
<b>6-13</b>	<b>WAYFINDING PLAN.....</b>	<b>51</b>
<b>6-14</b>	<b>BEHAVIORAL HEALTH.....</b>	<b>52</b>
<b>CHAPTER 7</b>	<b>STRUCTURAL .....</b>	<b>53</b>



7-1	<b>GENERAL</b> .....	<b>53</b>
7-2	<b>DESIGN CRITERIA</b> .....	<b>53</b>
7-3	<b>DESIGN LOADINGS</b> .....	<b>53</b>
7-3.1	Floor Live Loads .....	53
7-3.2	Seismic Loads .....	53
7-4	<b>ADDITIONAL DESIGN CONSIDERATIONS</b> .....	<b>53</b>
7-4.1	Vibration.....	53
<b>CHAPTER 8 SEISMIC</b> .....		<b>55</b>
8-1	<b>GENERAL</b> .....	<b>55</b>
8-2	<b>HEALTHCARE AND DESIGN REQUIREMENTS</b> .....	<b>55</b>
8-3	<b>POST-EARTHQUAKE EMERGENCY STATUS</b> .....	<b>55</b>
8-4	<b>CONCEPT DESIGN DEVELOPMENT</b> .....	<b>55</b>
8-5	<b>DESIGN OF NON-STRUCTURAL SYSTEMS</b> .....	<b>55</b>
8-5.1	Medical Systems and Equipment of Designated Seismic Systems ....	56
8-5.2	Medical Systems and Equipment for Non-Designated Seismic Systems 56	
8-5.3	Hazardous Materials.....	56
8-5.4	Electrical Systems .....	56
8-5.5	Medical Systems and Equipment.....	57
8-6	<b>EVALUATION OF EXISTING FACILITIES</b> .....	<b>57</b>
8-6.1	Seismic Hazards Evaluation Considerations .....	58
<b>CHAPTER 9 PLUMBING AND MEDICAL GASES</b> .....		<b>59</b>
9-1	<b>GENERAL</b> .....	<b>59</b>
9-1.1	Supplemental Criteria and Standards .....	59
9-1.2	Plumbing Systems .....	59
9-1.3	Medical Gas and Vacuum Systems .....	59
9-1.4	Seismic Requirements.....	59
9-1.5	Corrosion Protection .....	59
9-1.6	NFPA 99 Risk Assessment.....	60
9-1.7	Piping Coordination .....	60
9-2	<b>POTABLE WATER SUPPLY SYSTEM</b> .....	<b>60</b>
9-2.1	Quality.....	60
9-2.2	Continuity of Service.....	60

9-2.3	Backflow Prevention. ....	60
9-2.4	Water Treatment.....	62
9-2.5	Waterborne Pathogens.....	63
9-2.6	Domestic Hot Water Systems.....	65
9-2.7	Plumbing Fixtures and Other Equipment.....	67
9-2.8	Coordination with Medical and Dental Equipment.....	68
<b>9-3</b>	<b>SANITARY DRAINAGE SYSTEM.....</b>	<b>68</b>
9-3.1	Protection of Special Fixtures and Equipment.....	68
9-3.2	Special Drainage Equipment.....	68
9-3.3	Special Purpose Waste Lines.....	69
9-3.4	General-Purpose Floor Drains.....	69
9-3.5	Trap Priming.....	69
9-3.6	Retrofit or Alteration Considerations.....	69
9-3.7	Elevator Pit Sumps.....	69
9-3.8	Mercury Control.....	70
9-3.9	Dialysis Waste Box.....	70
<b>9-4</b>	<b>FUEL GAS SERVICE.....</b>	<b>70</b>
<b>9-5</b>	<b>MEDICAL GAS SYSTEMS.....</b>	<b>70</b>
9-5.1	Application of NFPA 99 to Dental Systems.....	72
9-5.2	Application of NFPA 99 to Veterinary Care.....	72
9-5.3	Systems for Medical Clinics.....	72
9-5.4	Systems for Dental Clinics.....	72
9-5.5	Criteria for Medical Gas Design in the Federal Republic of Germany (FRG). 72	
9-5.6	Medical Gas System Installation and Testing.....	73
9-5.7	System Control Valves.....	73
9-5.8	Alarm Systems.....	73
9-5.9	Gas System Sources (Storage).....	74
9-5.10	Color Coding and Labeling.....	74
9-5.11	Medical Gas Systems Outlets.....	74
9-5.12	Power Source for Medical Gas Systems.....	75
9-5.13	Medical Compressed Air (MA).....	75
9-5.14	Dental Compressed Air (DA).....	77

9-5.15	Laboratory Air (LA).....	79
9-5.16	Instrument Air (IA).....	80
9-5.17	Process Air (PA).....	81
9-5.18	Medical Surgical Vacuum (MV) System.....	81
9-5.19	Dental Surgical Vacuum (DSV).....	85
9-5.20	Oral Evacuation (OE).....	86
9-5.21	High-Volume Laboratory Dust Evacuation (LDE).....	88
9-5.22	Waste Anesthesia Gas Disposal (WAGD).....	89
9-5.23	Oxygen (O).....	90
9-5.24	Nitrous Oxide (NO).....	92
9-5.25	Nitrogen (N).....	92
9-5.26	Carbon Dioxide (CO <sub>2</sub> ).....	93
9-5.27	Process Gas.....	93
<b>CHAPTER 10 HEATING, VENTILATION, AND AIR CONDITIONING.....</b>		<b>95</b>
<b>10-1</b>	<b>GENERAL.....</b>	<b>95</b>
10-1.1	Applicability.....	95
10-1.2	Supporting Documents.....	95
<b>10-2</b>	<b>DESIGN CONDITIONS.....</b>	<b>95</b>
10-2.1	Weather Data.....	95
10-2.2	Interior Design Conditions.....	95
10-2.3	Space Ventilation.....	96
10-2.4	Ambient Outdoor Design Conditions.....	96
10-2.5	Critical Care Spaces.....	96
10-2.6	Laboratories.....	97
10-2.7	Temperature during Smoke Control Operation.....	97
10-2.8	Mechanical Equipment Rooms.....	97
10-2.9	Humid Climate Definition.....	97
10-2.10	NFPA 99 Risk Assessment.....	98
<b>10-3</b>	<b>REFRIGERANTS.....</b>	<b>98</b>
<b>10-4</b>	<b>LIFE-CYCLE COST AND ENERGY ANALYSIS.....</b>	<b>98</b>
<b>10-5</b>	<b>ELIGIBILITY FOR AIR CONDITIONING.....</b>	<b>98</b>
10-5.1	Total Air Conditioning.....	98
10-5.2	Food Service Area.....	98

10-5.3	Medical Warehouses. ....	98
<b>10-6</b>	<b>MECHANICAL EQUIPMENT SPACE. ....</b>	<b>99</b>
10-6.2	Energy Plant.....	100
<b>10-7</b>	<b>HVAC SYSTEM DESIGN FOR FUNCTIONAL AREAS. ....</b>	<b>100</b>
10-7.1	Critical Care Spaces. ....	100
10-7.2	Sensitive Equipment Areas.....	102
10-7.3	Patient Bedrooms. ....	102
10-7.4	Temporary and Deployable Facilities.....	102
10-7.5	Rooms with Critical Pressurization Requirements.....	102
<b>10-8</b>	<b>GENERAL DESIGN CONSIDERATIONS. ....</b>	<b>103</b>
10-8.1	Plant Sizing and Optimization. ....	103
10-8.2	Contaminant Removal. ....	104
10-8.3	Interdepartmental Air System Restriction.....	104
10-8.4	Air Filtration.....	105
10-8.5	Balancing Ports and Features.....	105
10-8.6	Additions and Alterations to Existing Facilities.....	105
10-8.7	Cooling and Heating Load Calculations.....	106
10-8.8	Piping Systems.....	107
10-8.9	Insulation for Mechanical Systems. ....	108
<b>10-9</b>	<b>HVAC SYSTEM CONTROLS.....</b>	<b>108</b>
10-9.1	Energy Conservation. ....	108
10-9.2	Temperature Control.....	108
10-9.3	Control Precision. ....	109
10-9.4	Humidity Control. ....	109
10-9.5	Direct Digital Controls (DDC).....	110
10-9.6	Air Handling Equipment Control.....	110
<b>10-10</b>	<b>STEAM SYSTEMS. ....</b>	<b>111</b>
10-10.1	Humidification Steam Source.....	111
10-10.2	Sterilizer Steam Source. ....	112
<b>10-11</b>	<b>AIR HANDLING AND DISTRIBUTION.....</b>	<b>112</b>
10-11.1	AHU Requirements.....	112
10-11.2	System Shutdown Capability. ....	112
10-11.3	Outdoor Air Intakes.....	113

10-11.4	Noise Control.....	113
10-11.5	Duct Design.....	114
10-11.6	Cleanliness of Air Handling and Distribution Equipment.....	116
<b>10-12</b>	<b>MAINTENANCE PROVISIONS.....</b>	<b>116</b>
10-12.1	General Personnel Access.....	116
10-12.2	Equipment Clearances.....	117
10-12.3	Suspended and Mounted Mechanical Equipment.....	117
10-12.4	Air Distribution System Components.....	117
10-12.5	HVAC System Balancing Provisions.....	117
<b>10-13</b>	<b>VIBRATION CONTROL.....</b>	<b>117</b>
<b>10-14</b>	<b>INTERDISCIPLINARY COORDINATION.....</b>	<b>117</b>
10-14.1	Architectural Coordination for Rooms with Critical Pressurization Requirements.....	117
10-14.2	Fire Protection Features.....	118
10-14.3	Essential Electrical Service.....	118
10-14.4	Seismic Design Requirements.....	119
10-14.5	Design Coordination.....	119
<b>10-15</b>	<b>FUEL STORAGE REQUIREMENTS.....</b>	<b>120</b>
<b>10-16</b>	<b>VENTILATION DESIGN.....</b>	<b>120</b>
10-16.1	Ventilation Air Changes.....	120
10-16.2	General Exhaust Provisions.....	121
10-16.3	Space Pressurization.....	121
10-16.4	Laboratory Ventilation.....	121
10-16.5	Exhaust Canopies.....	123
10-16.6	Laminar Flow Clean Benches.....	123
10-16.7	Bench-Back Slot Hoods.....	123
10-16.8	Portable Bench-Top Hoods.....	123
10-16.9	Medical Equipment.....	124
10-16.10	Kitchen Hoods.....	124
10-16.11	Pharmaceutical Admixture Rooms.....	124
<b>10-17</b>	<b>AIRBORNE INFECTION ISOLATION AND PROTECTIVE ENVIRONMENT ROOM DESIGN.....</b>	<b>124</b>
10-17.1	Airborne Infection Isolation Bedrooms.....	124
10-17.2	Protective Environment Rooms.....	125

10-17.3	Airborne Infection Isolation Exam or Waiting Rooms.....	126
<b>CHAPTER 11</b>	<b>ELECTRICAL .....</b>	<b>127</b>
<b>11-1</b>	<b>GENERAL.....</b>	<b>127</b>
11-1.1	Scope.....	127
11-1.2	Supplemental Criteria and Standards.....	127
11-1.3	OCONUS Criteria .....	130
<b>11-2</b>	<b>AREA DESIGNATIONS.....</b>	<b>130</b>
11-2.1	Patient Care Space.....	130
11-2.2	Wet Locations.....	130
11-2.3	Wet Procedure Locations.....	131
<b>11-3</b>	<b>EXTERIOR ELECTRICAL.....</b>	<b>131</b>
11-3.1	Primary Voltage.....	131
11-3.2	Normal Source Site Investigation.....	131
11-3.3	Hospital Normal System.....	131
11-3.4	Outpatient Clinics Normal System.....	133
11-3.5	Ambulatory Healthcare Centers Normal System.....	133
11-3.6	Grounding.....	133
<b>11-4</b>	<b>ESSENTIAL ELECTRICAL SYSTEM.....</b>	<b>133</b>
11-4.1	Facility.....	133
11-4.2	General.....	135
11-4.3	Alternate Power Source.....	135
11-4.4	Load Shed Restoration System.....	135
11-4.5	Generator Sets.....	136
11-4.6	Location of Generator Sets.....	137
11-4.7	Engine Starting.....	137
11-4.8	Manual Test Switches.....	137
11-4.9	Generator Set Operation.....	138
11-4.10	Return to Normal Power Source.....	138
11-4.11	Automatic Transfer Switch (ATS).....	139
11-4.12	Ground Fault Protection Equipment.....	140
11-4.13	Remote Alarm Annunciator.....	140
11-4.14	Fuel Storage Tanks.....	140
11-4.15	Loads on the Alternate Source.....	141

11-4.16	Essential Loads. ....	142
11-4.17	Alternate Source Testing. ....	145
<b>11-5</b>	<b>INTERIOR ELECTRICAL SYSTEMS. ....</b>	<b>145</b>
11-5.1	Utilization Voltage. ....	145
11-5.2	Interior Distribution. ....	145
11-5.3	Short Circuit, Selective Coordination, and Arc Flash. ....	147
11-5.4	Electrical Rooms. ....	147
11-5.5	Isolation Power Panel. ....	149
11-5.6	Conduit, Cable Tray, and Wire. ....	149
11-5.7	Branch Circuits. ....	150
11-5.8	Radiology Provisions. ....	150
11-5.9	Receptacles. ....	150
11-5.10	Receptacle Identification. ....	154
11-5.11	Patient Care Grounding. ....	155
11-5.12	Inhalation Anesthetizing Location. ....	155
11-5.13	Electromagnetic Shielding for Medical Instrumentation. ....	155
<b>11-6</b>	<b>LIGHTING. ....</b>	<b>155</b>
11-6.1	Design. ....	155
11-6.2	Battery-Operated Lighting. ....	159
11-6.3	Patient Bedrooms. ....	160
11-6.4	Other Rooms. ....	160
11-6.5	Dental Clinic. ....	161
11-6.6	Eye LASIK/PRK Rooms. ....	161
11-6.7	Exterior Signage. ....	161
11-6.8	Exterior Lighting. ....	161
11-6.9	Dimming. ....	162
11-6.10	Ultraviolet (UV) Filters. ....	162
11-6.11	Maintenance Area Lighting. ....	162
11-6.12	Auditorium. ....	162
11-6.13	Continuity of Service. ....	162
11-6.14	Accessibility. ....	163
<b>11-7</b>	<b>HELIPAD LIGHTING, MARKING, AND CONTROLS. ....</b>	<b>163</b>
<b>11-8</b>	<b>LIGHTNING PROTECTION. ....</b>	<b>164</b>

<b>CHAPTER 12 COMMUNICATIONS .....</b>	<b>173</b>
<b>12-1 GENERAL .....</b>	<b>173</b>
12-1.1 Design Criteria .....	173
12-1.2 Approved Product Lists (APLs).....	173
<b>12-2 COMMUNICATIONS SPACES. ....</b>	<b>173</b>
12-2.1 Telecommunication Rooms (TRs). ....	173
12-2.2 Penthouse Equipment Room.....	176
12-2.3 Communications Radio Equipment Room (COM04). ....	176
12-2.4 Integrated Monitor and Alarm Room.....	176
12-2.5 Server Room (CMP01). ....	177
12-2.6 Telecommunications Entrance Facility (EF) COMC2.....	177
<b>12-3 OUTSIDE PLANT INFRASTRUCTURE AND CABLING. ....</b>	<b>177</b>
12-3.1 Outside Plant Purpose.....	177
12-3.2 Outside Plant Duct Work.....	177
12-3.3 Outside Plant FO Cable.....	178
12-3.4 Outside Plant Twisted Pair Copper Cable. ....	178
12-3.5 Outside Plant CATV Cable.....	178
<b>12-4 DOD NETWORK ASSESSMENT AND AUTHORIZATION PROCESS     REQUIREMENTS. ....</b>	<b>178</b>
12-4.1 IP Addressable Systems.....	178
12-4.2 Existing Systems. ....	179
<b>12-5 NETWORK TIME SYNCHRONIZATION (NTS) SYSTEM.....</b>	<b>179</b>
12-5.1 Purpose.....	179
12-5.2 Date and Time Properties.....	179
12-5.3 Electrical Power. ....	179
<b>12-6 TELEPHONE SYSTEM CRITERIA. ....</b>	<b>180</b>
12-6.1 Type of Service.....	180
12-6.2 Central Telephone Equipment. ....	180
12-6.3 Integrated Intercommunication (Intercom) System. ....	180
12-6.4 Patient Bedside Telephones.....	181
<b>12-7 TELECOMMUNICATIONS INFRASTRUCTURE SYSTEM (TIS). ....</b>	<b>181</b>
12-7.1 UTP Copper Backbone Cable.....	181
12-7.2 FO Backbone Cable. ....	181



12-7.3	Horizontal Copper Cable.....	182
12-7.4	Horizontal FO Cable. ....	182
12-7.5	Work Area Outlets (WAO).....	182
12-7.6	Data Communications Wireless Access Points (WAPs).....	183
12-7.7	Cable Tray. ....	184
12-7.8	Grounding. ....	184
<b>12-8</b>	<b>DEDICATED INTERCOM SYSTEM. ....</b>	<b>184</b>
<b>12-9</b>	<b>NURSE CALL SYSTEMS.....</b>	<b>184</b>
12-9.1	Purpose. ....	184
12-9.2	Categories and Typical Locations.....	184
12-9.3	Procurement. ....	185
12-9.4	UL 1069. ....	185
12-9.5	Common Criteria.....	185
12-9.6	Networked NCAV Systems.....	188
12-9.7	NCTV Systems. ....	199
12-9.8	Enhanced Supplemental Operations. ....	202
<b>12-10</b>	<b>INTERNAL CELLULAR, PAGING AND ANTENNA SYSTEM (IRES)..</b>	<b>202</b>
<b>12-11</b>	<b>RADIO PAGING SYSTEMS.....</b>	<b>203</b>
12-11.1	Radio Paging (RP).....	203
12-11.2	Page System Interfaces.....	203
12-11.3	System Function. ....	203
12-11.4	Emergency Response Team Pagers. ....	203
12-11.5	Antennae Type and Mounting.....	203
12-11.6	Power Requirements. ....	204
12-11.7	Transmitter and Encoder. ....	204
<b>12-12</b>	<b>INTERACTIVE TELEVISION (ITV) SYSTEM.....</b>	<b>204</b>
12-12.1	Electrical Power. ....	204
12-12.2	Empty Conduit and Boxes and Cable Trays. ....	204
12-12.3	Structural Support.....	204
12-12.4	Equipment Space Support. ....	204
<b>12-13</b>	<b>TV BROADBAND DISTRIBUTION NETWORK.....</b>	<b>205</b>
12-13.1	Purpose. ....	205
12-13.2	Procurement. ....	205

12-13.3	Commercial TV Service. ....	205
12-13.4	Broadband Distribution Network. ....	205
12-13.5	TV Outlets and Signal Level. ....	206
12-13.6	Flat-Panel HDTVs and Connecting and Mounting Items Configuration. 206	
12-13.7	Electrical Power. ....	206
<b>12-14</b>	<b>ELECTRONIC SECURITY SYSTEM (ESS). ....</b>	<b>206</b>
<b>12-15</b>	<b>RADIO AND PUBLIC ADDRESS (PA) SYSTEM. ....</b>	<b>207</b>
12-15.1	System Purpose. ....	207
12-15.2	System Components. ....	207
12-15.3	System Configuration. ....	208
12-15.4	System Performance. ....	209
12-15.5	Electrical Power. ....	209
12-15.6	DoD Assessment and Authorization. ....	210
<b>12-16</b>	<b>SOUND REINFORCEMENT SYSTEMS. ....</b>	<b>210</b>
12-16.1	Purpose. ....	210
12-16.2	Inputs. ....	210
12-16.3	Headroom. ....	211
<b>12-17</b>	<b>INTEGRATED AUDIO VIDEO SYSTEMS (AV) ....</b>	<b>211</b>
<b>12-18</b>	<b>PATIENT MONITORING AND TELEMETRY SYSTEMS. ....</b>	<b>211</b>
12-18.1	Cardio-Pulmonary Respiratory Monitoring. ....	212
12-18.2	Fetal Monitoring. ....	212
12-18.3	Neonatal Monitoring. ....	213
12-18.4	Anesthesia and Respiratory Gas Analysis System. ....	213
<b>12-19</b>	<b>EMERGENCY MEDICAL SERVICE (EMS) COMMUNICATIONS. ....</b>	<b>213</b>
12-19.1	Electrical Power. ....	213
12-19.2	Empty Conduit and Boxes. ....	213
12-19.3	Structural Support. ....	213
<b>12-20</b>	<b>EMS RECORDER SYSTEM. ....</b>	<b>213</b>
12-20.1	EMS Recorder Function and Features. ....	214
12-20.2	System Inputs and Mounting. ....	214
12-20.3	DoD Assessment and Authorization. ....	214
<b>12-21</b>	<b>OTHER PROVIDED SYSTEMS ....</b>	<b>214</b>

12-21.1	Electrical Power.....	215
12-21.2	Empty Conduit and Boxes and Cable Trays.....	215
12-21.3	Structural Support.....	215
12-21.4	Equipment Space Support.....	215
<b>CHAPTER 13 ACCESSIBILITY PROVISIONS FOR THE DISABLED.....</b>		<b>217</b>
<b>13-1</b>	<b>GENERAL.....</b>	<b>217</b>
<b>13-2</b>	<b>GENERAL EXCEPTIONS.....</b>	<b>217</b>
<b>13-3</b>	<b>DOD EXCEPTIONS/EXCLUSIONS.....</b>	<b>217</b>
<b>13-4</b>	<b>SPECIFIC MILITARY MEDICAL FACILITY REQUIREMENTS.....</b>	<b>217</b>
13-4.1	Parking.....	217
13-4.2	Patient Sleeping Rooms.....	217
13-4.3	Patient Dressing Rooms.....	217
13-4.4	Telephones.....	217
<b>13-5</b>	<b>WAIVERS.....</b>	<b>218</b>
<b>CHAPTER 14 FIRE PROTECTION AND LIFE SAFETY.....</b>		<b>219</b>
<b>14-1</b>	<b>GENERAL.....</b>	<b>219</b>
<b>14-2</b>	<b>BUILDING REHABILITATION.....</b>	<b>219</b>
14-2.1	Life Safety Assessment.....	219
14-2.2	Smoke Control or Management Systems.....	220
<b>14-3</b>	<b>CONSTRUCTION OPERATIONS.....</b>	<b>220</b>
14-3.1	Phasing.....	220
14-3.2	Impairment of Existing Fire Protection Systems and Features.....	220
<b>14-4</b>	<b>AUTOMATIC SPRINKLER PROTECTION.....</b>	<b>220</b>
14-4.1	Clarification of Spaces to Be Protected.....	221
14-4.2	Preaction and Deluge Systems.....	221
14-4.3	System Supervision.....	221
14-4.4	Defend in Place.....	221
14-4.5	Components and Hardware.....	221
<b>14-5</b>	<b>PORTABLE FIRE EXTINGUISHERS.....</b>	<b>222</b>
<b>14-6</b>	<b>FIRE ALARM, FIRE DETECTION, AND MASS NOTIFICATION.....</b>	<b>222</b>
14-6.1	Facility Fire Plan.....	222
14-6.2	Autonomous Control Unit and Local Operating Consoles.....	222
14-6.3	Occupant Notification.....	222

14-6.4	Smoke Detection Used in Conjunction with Smoke Compartmentation. 224	
<b>14-7</b>	<b>MANAGEMENT OF SMOKE</b> .....	<b>224</b>
14-7.1	New Smoke Control Systems. ....	224
14-7.2	Existing Smoke Control Systems.....	224
14-7.3	Smokeproof Enclosures.....	224
<b>14-8</b>	<b>WATER SUPPLY</b> . ....	<b>224</b>
<b>14-9</b>	<b>INTERSTITIAL BUILDING SYSTEM (IBS)</b> . ....	<b>225</b>
<b>14-10</b>	<b>SPECIAL DETAILED REQUIREMENTS BASED ON USE AND OCCUPANCY</b> . ....	<b>225</b>
14-10.1	Dental Treatment Facilities. ....	225
14-10.2	Laboratories.....	225
14-10.3	Veterinary Care and Animal Research Facilities.....	226
14-10.4	Helipads.....	226
14-10.5	Pharmacy Storage. ....	226
<b>CHAPTER 15</b>	<b>EQUIPMENT</b> .....	<b>227</b>
<b>15-1</b>	<b>GENERAL</b> . ....	<b>227</b>
15-1.1	Identification of Equipment.....	227
15-1.2	Approval of Substitutions. ....	227
<b>15-2</b>	<b>PROCUREMENT</b> .....	<b>227</b>
<b>15-3</b>	<b>FUNDING CATEGORY</b> .....	<b>227</b>
<b>15-4</b>	<b>LOGISTICAL RESPONSIBILITY</b> . ....	<b>228</b>
<b>15-5</b>	<b>DESIGN</b> .....	<b>228</b>
15-5.1	Casework.....	228
15-5.2	Technically Complex Equipment and Medical System. ....	229
15-5.3	Equipment Connectivity .....	229
15-5.4	Hyperbaric Medicine. ....	229
<b>CHAPTER 16</b>	<b>TRANSPORTATION AND LOGISTICS</b> .....	<b>231</b>
<b>16-1</b>	<b>GENERAL</b> . ....	<b>231</b>
16-1.1	Scope.....	231
16-1.2	Transportation Systems Evaluation. ....	232
16-1.3	Medical Transportation and Logistics Consultant (MTLC). ....	232
<b>16-2</b>	<b>TRANSPORTATION AND LOGISTIC ANALYSIS REQUIREMENTS</b> . .	<b>232</b>
16-2.1	Transportation Logistic Analysis (TLA). ....	232

16-2.2	Elevator Traffic Study and Analysis (ETSA).....	234
16-2.3	Material Management Analysis (MMA).....	235
16-2.4	Waste Management Analysis (WMA).....	235
16-3	<b>FACILITY DESIGN.....</b>	<b>236</b>
16-3.1	Traffic Separation.....	236
16-3.2	Transportation Systems.....	237
16-3.3	Vertical Automation.....	237
16-3.4	Equipment/Materials Separation.....	237
16-3.5	Clean and Soiled Material Separation.....	238
16-3.6	Escalators.....	238
16-4	<b>ELEVATOR DESIGN.....</b>	<b>238</b>
16-4.1	Codes.....	238
16-4.2	Elevator Selection.....	239
16-4.3	Elevator Location and Travel Distances.....	243
16-4.4	Elevator Location, Lobbies, and Groupings.....	243
16-4.5	Passenger and Service Elevator Features.....	244
16-5	<b>MATERIAL MANAGEMENT DESIGN.....</b>	<b>247</b>
16-5.1	AGV Systems.....	247
16-5.2	Pneumatic Tubes.....	248
16-5.3	Mobile Robots.....	248
16-5.4	Dumbwaiters and Cart Lifts.....	248
16-6	<b>WASTE MANAGEMENT DESIGN.....</b>	<b>249</b>
16-6.1	Waste Categories.....	249
16-6.2	Waste Collection and Transport.....	250
16-6.3	Regulations, Codes, and Standards.....	250
16-6.4	Gravity Chutes.....	250
16-6.5	Pneumatic Trash/Linen.....	251
<b>CHAPTER 17 CONSTRUCTION .....</b>		<b>253</b>
17-1	<b>CONTRACT AWARD.....</b>	<b>253</b>
17-2	<b>COMMISSIONING DURING CONSTRUCTION.....</b>	<b>253</b>
17-3	<b>CONSTRUCTION CONTRACT CHANGES.....</b>	<b>253</b>
17-3.1	Process for Reporting Changes.....	253
17-3.2	Process for Approving Funds.....	253

<b>17-4</b>	<b>CONSTRUCTION FUNDS.....</b>	<b>253</b>
17-4.1	Funds Management.....	253
17-4.2	Funds Availability.....	253
<b>17-5</b>	<b>CONTRACTOR CLAIMS.....</b>	<b>254</b>
17-5.1	Notification.....	254
<b>17-6</b>	<b>LIFE SAFETY CERTIFICATION.....</b>	<b>254</b>
17-6.1	Life Safety Assessment.....	254
<b>17-7</b>	<b>DEMOLITION OF VACATED FACILITIES.....</b>	<b>254</b>
<b>CHAPTER 18 BUILDING INFORMATION MODELING (BIM).....</b>		<b>255</b>
<b>18-1</b>	<b>GENERAL.....</b>	<b>255</b>
18-1.1	BIM Objectives.....	255
18-1.2	Minimum BIM Standards.....	255
<b>CHAPTER 19 COMMISSIONING.....</b>		<b>257</b>
<b>19-1</b>	<b>GENERAL.....</b>	<b>257</b>
<b>19-2</b>	<b>SUPPLEMENTAL CRITERIA.....</b>	<b>257</b>
<b>19-3</b>	<b>TOTAL BUILDING COMMISSIONING.....</b>	<b>257</b>
19-3.1	Process Overview.....	257
19-3.2	Commissioning Leadership Structure.....	258
19-3.3	Commissioning During Design.....	260
19-3.4	Commissioning During Construction.....	261
<b>19-4</b>	<b>SPECIFIC SYSTEM REQUIREMENTS.....</b>	<b>261</b>
19-4.1	Interoperability.....	261
19-4.2	Addition and Alteration Considerations.....	261
<b>APPENDIX A BEHAVIORAL HEALTH DESIGN.....</b>		<b>263</b>
<b>A-1</b>	<b>GENERAL.....</b>	<b>263</b>
<b>A-2</b>	<b>SCOPE OF BEHAVIORAL HEALTH SERVICES.....</b>	<b>263</b>
A-2.1	Inpatient Functions.....	263
A-2.2	Outpatient Functions.....	263
<b>A-3</b>	<b>BEHAVIORAL HEALTH PROGRAM.....</b>	<b>263</b>
A-3.1	Concept.....	263
A-3.2	Design Guide for the Built Environment of Behavioral Health Facilities. 264	
<b>A-4</b>	<b>CONSULTING SERVICES.....</b>	<b>264</b>

<b>A-5</b>	<b>DESIGN CRITERIA</b> .....	<b>264</b>
A-5.1	Environment.....	264
<b>A-6</b>	<b>EQUIPMENT SPECIFICATIONS</b> .....	<b>272</b>
<b>APPENDIX B ARCHITECTURAL AND ENGINEERING DESIGN REQUIREMENTS</b>		<b>273</b>
<b>B-1</b>	<b>SYNOPSIS</b> .....	<b>273</b>
<b>B-2</b>	<b>LEGEND &amp; NOTES</b> .....	<b>273</b>
B-2.1	Room Code.....	273
B-2.2	Room Function. ....	273
B-2.3	Space Parameter Notes.....	274
<b>B-3</b>	<b>ARCHITECTURAL</b> .....	<b>274</b>
B-3.1	Materials and Finishes.....	274
B-3.2	CLG HT.....	276
B-3.3	DOOR SIZE.....	276
B-3.4	NOISE.....	277
<b>B-4</b>	<b>ARCHITECTURAL NOTES</b> .....	<b>278</b>
<b>B-5</b>	<b>STRUCTURAL</b> .....	<b>280</b>
<b>B-6</b>	<b>ELECTRICAL</b> .....	<b>280</b>
B-6.1	LIGHT. ....	280
B-6.2	ES PWR.....	281
<b>B-7</b>	<b>MEDICAL GASES</b> .....	<b>281</b>
B-7.1	MEDICAL GAS NOTES.....	282
<b>B-8</b>	<b>HVAC</b> .....	<b>283</b>
<b>APPENDIX C DESIGN SUBMITTALS AND DOCUMENTATION</b>		<b>317</b>
<b>C-1</b>	<b>GENERAL</b> .....	<b>317</b>
<b>C-2</b>	<b>APPLICATION</b> .....	<b>317</b>
<b>C-3</b>	<b>GENERAL REQUIREMENTS</b> .....	<b>317</b>
C-3.1	Narratives and Format.....	317
C-3.2	Drawings and Format. ....	317
C-3.3	Building Systems Risk Assessment.....	318
<b>C-4</b>	<b>5 PERCENT SUBMITTAL</b> .....	<b>318</b>
C-4.1	5 Percent Submittal Narratives. ....	318
C-4.2	5 Percent Submittal Drawings.....	318
C-4.3	5 Percent Submittal Cost Estimates. ....	319

<b>C-5</b>	<b>20 PERCENT SUBMITTAL</b> .....	<b>320</b>
C-5.1	Scope Changes .....	320
C-5.2	Record Copy.....	320
C-5.3	20 Percent Design Narratives.....	320
C-5.4	20 Percent Submittal Design Drawings.....	324
C-5.5	20 Percent Submittal Calculations.....	325
<b>C-6</b>	<b>35 PERCENT SUBMITTAL</b> .....	<b>326</b>
C-6.1	35 Percent Submittal Design Narratives.....	326
<b>C-7</b>	<b>35 PERCENT SUBMITTAL DESIGN DRAWINGS</b> .....	<b>330</b>
C-7.1	World-Class Checklist.....	330
C-7.2	35 Percent Submittal Calculations.....	334
C-7.3	35 Percent Submittal Cost Estimates.....	334
C-7.4	35 Percent Design Drawing Record Copy.....	334
<b>C-8</b>	<b>65 PERCENT DESIGN SUBMITTAL</b> .....	<b>334</b>
<b>C-9</b>	<b>100 PERCENT AND FINAL DESIGN SUBMITTAL</b> .....	<b>334</b>
<b>C-10</b>	<b>STATEMENT OF CONDITIONS (SOC)</b> .....	<b>335</b>
<b>C-11</b>	<b>REQUEST FOR PROPOSAL (RFP) FOR DESIGN-BUILD (DB) PROJECTS</b> .....	<b>335</b>
<b>C-12</b>	<b>RFP DEVELOPMENT SUBMITTALS</b> .....	<b>335</b>
<b>C-13</b>	<b>AFTER CONTRACT AWARD</b> .....	<b>336</b>
<b>APPENDIX D</b>	<b>UNIVERSAL X-RAY ROOM</b> .....	<b>337</b>
<b>D-1</b>	<b>GENERAL</b> .....	<b>337</b>
D-1.1	Applications.....	337
<b>D-2</b>	<b>SPECIFIC REQUIREMENTS</b> .....	<b>337</b>
D-2.1	Electrical Raceway System.....	337
D-2.2	Floor Trench.....	337
D-2.3	Core Drilling.....	337
D-2.4	Wall Ducts.....	337
D-2.5	Electrical Service Requirements.....	338
<b>D-3</b>	<b>WARNING LIGHTS</b> .....	<b>339</b>
<b>D-4</b>	<b>STRUCTURAL REQUIREMENTS</b> .....	<b>339</b>
D-4.2	Fire Protection.....	340
<b>APPENDIX E</b>	<b>INTERSTITIAL BUILDING SYSTEM (IBS)</b> .....	<b>345</b>



<b>E-1</b>	<b>GENERAL</b> .....	<b>345</b>
<b>E-2</b>	<b>IBS DESIGN CONCEPT</b> .....	<b>345</b>
E-2.1	DoD Systems Module Concept.....	345
E-2.2	Alternate Non-Modular Concept. ....	346
E-2.3	IBS Design Concept Approval. ....	346
<b>E-3</b>	<b>IBS DESIGN</b> .....	<b>347</b>
E-3.1	DoD Systems Module Design.....	347
E-3.2	Alternate (Non-DoD) IBS Design. ....	348
E-3.3	General IBS Design Requirements.....	349
E-3.4	General IBS Mechanical and Plumbing Requirements.....	351
E-3.5	General IBS Electrical and Communications Equipment.....	352
E-3.6	General IBS Fire Protection Design.....	354
E-3.7	Documentation and Construction Considerations.....	360
<b>APPENDIX F FOOD SERVICE</b> .....		<b>363</b>
<b>F-1</b>	<b>GENERAL</b> .....	<b>363</b>
<b>F-2</b>	<b>CONSULTING SERVICES</b> .....	<b>363</b>
<b>F-3</b>	<b>FOOD SERVICE DESIGN OBJECTIVES</b> .....	<b>363</b>
F-3.1	Environment.....	363
F-3.2	Design Elements.....	363
F-3.3	Design Flexibility.....	363
F-3.4	Equipment.....	364
F-3.5	Energy Efficiency and Sustainability.....	364
F-3.6	Food Service Systems.....	364
<b>F-4</b>	<b>DESIGN CRITERIA</b> .....	<b>364</b>
F-4.1	Design.....	364
F-4.2	Configuration. ....	365
F-4.3	Staging.....	365
F-4.4	Refrigerator and Freezer.....	365
F-4.5	Patient Tray Assembly.....	366
F-4.6	Dishwashing and Ware Washing.....	366
F-4.7	Communications.....	367
F-4.8	Waste Handling. ....	368
F-4.9	Emergency Power. ....	368

F-4.10	Steam.....	368
F-4.11	Shelving.....	368
F-4.12	Plumbing.....	368
F-4.13	Compliance Standards.....	369
F-4.14	Exhaust Hoods.....	369
F-4.15	Interior Finishes.....	369
F-4.16	Data Processing Equipment and Security.....	370
F-4.17	Grease Traps.....	370
F-4.18	Sealants.....	370
F-4.19	Franchised/Leased Food Services.....	370
<b>F-5</b>	<b>SEISMIC CRITERIA.....</b>	<b>370</b>
<b>F-6</b>	<b>FOOD SERVICE EQUIPMENT SPECIFICATIONS.....</b>	<b>371</b>
<b>APPENDIX G PARKING REQUIREMENTS.....</b>		<b>373</b>
<b>G-1</b>	<b>GENERAL.....</b>	<b>373</b>
<b>G-2</b>	<b>PARKING AUTHORITY.....</b>	<b>373</b>
G-2.1	Facilities and Location.....	373
<b>APPENDIX H GLOSSARY.....</b>		<b>375</b>
<b>H-1</b>	<b>ACRONYMS.....</b>	<b>375</b>
<b>H-2</b>	<b>DEFINITION OF TERMS.....</b>	<b>387</b>
<b>APPENDIX I REFERENCES.....</b>		<b>405</b>

## FIGURES

<b>Figure 3-1</b>	<b>Instructions for Preparing Gross Area Tabulation.....</b>	<b>23</b>
<b>Figure 3-2</b>	<b>Instructions for Preparing Departmental Gross Area Calculations ..</b>	<b>25</b>
<b>Figure 9-1</b>	<b>Simultaneous Use Factors for Medical Vacuum.....</b>	<b>84</b>
<b>Figure 11-1</b>	<b>Hospital One-line Traditional Diagram.....</b>	<b>132</b>
<b>Figure 11-2</b>	<b>Multi-Ended Network Substation System Diagram.....</b>	<b>169</b>
<b>Figure 11-3</b>	<b>Expandable Dual-Ended Substation.....</b>	<b>171</b>
<b>Figure D-1</b>	<b>Floor Plan.....</b>	<b>341</b>
<b>Figure D-2</b>	<b>Above Ceiling Plan.....</b>	<b>342</b>
<b>Figure D-3</b>	<b>Elevations.....</b>	<b>343</b>
<b>Figure E-1</b>	<b>DoD IBS Systems Module (Typical).....</b>	<b>346</b>
<b>Figure E-2</b>	<b>Interstitial Design Elements.....</b>	<b>349</b>

Figure E-3 Interstitial Access-Egress (Typical) ..... 351

**TABLES**

Table 3-1 Gross Area Accounting Rules ..... 16

Table 5-1 Intrusion Detection and Duress Alarm Locations and Sensor Types 39

Table 9-1 Potential Backflow Preventer Discharge Rates ..... 61

Table 9-2 Floor Drain Flow Rates ..... 62

Table 9-3 Hot Water Demand per Fixture for MTFs ..... 65

Table 9-4 Medical Gas Systems<sup>a</sup> ..... 70

Table 9-5 Medical Compressed Air (MA) System Demand<sup>1</sup> ..... 76

Table 9-6 Receiver Size ..... 79

Table 9-7 Medical Laboratory Air (LA) System Demand ..... 80

Table 9-8 Medical Vacuum Source Sizing ..... 82

Table 9-9 DSV Demand Factors ..... 86

Table 9-10 LDE System Utilization Factors ..... 89

Table 9-11 Oxygen System Utilization Factors ..... 91

Table 9-12 Cylinder Manifold Systems ..... 91

Table 9-13 Oxygen Bulk Tank Sizes ..... 92

Table 9-14 Process Gas Utilization Factors ..... 94

Table 11-1 Continuous and Emergency-Rated Diesel-Electric Generator Sets for Military Medical Facilities ..... 136

Table 11-2 Sample Nonlinear Load Analysis Matrix ..... 146

Table 11-3 Medical Helipad Visual Facilities Requirements ..... 163

Table 12-1 Essential Electrical System Emergency Power Branch Assignment for Communication Systems ..... 175

Table 12-2 Call Annunciation Priorities ..... 196

Table 15-1 Logistical Responsibility (LOGCAT) ..... 228

Table 16-1 Analysis Requirements ..... 231

Table 16-2 Elevator Traffic Separation Guide ..... 237

Table 16-3 Elevator Selection Guide ..... 240

Table 16-4 Elevator Dimension – Front Openings Guide ..... 241

Table 16-5 Elevator Dimension – Front and Rear Openings Guide ..... 242

Table 19-1 Commissioning Lead Personnel Qualifications ..... 260

**Table B-1 Architectural and Engineering Design Criteria..... 288**  
**Table G-1 Required Parking Spaces for Military Medical Facilities ..... 374**

CANCELLED

## CHAPTER 1 INTRODUCTION

### 1-1 PURPOSE AND SCOPE.

This Unified Facilities Criteria (UFC) 4-510-01 provides technical guidance and mandatory requirements to implement laws, regulations, executive orders, and policies to sustain, operate, plan, design, and construct DoD medical, dental and all other medically related facilities authorized by Title 10, United States Code (Reference (k)) and policies; and defines performance and quality requirements as defined in MIL-STD-3007 for Military Medical Facilities, also referenced as Medical Treatment Facilities (MTFs) supporting Health Service Support as defined in Joint Publication 4-02 (JP 4-02) throughout the life-cycle. Latest or most current Federal legislation, Executive Orders (EOs), DoD Directives, DoD Instructions, and selected technical data, publications, and standards are referenced in the text by basic designation only and form a part of these criteria to the extent required by these references.

### 1-2 APPLICABILITY.

UFC 4-510-01 (hereafter 'this document') applies to medically unique portions of military medical facilities in the DoD Medical (DoDM) Military Construction (MILCON) program, or other medically specific appropriations as provided by Congress. These requirements also apply to veterinary, medical-related research, and medical training facilities. This document should be employed by the Department of Defense (DoD) Components to sustainment, restoration or modernization projects where feasible and cost effective, in facility additions or alteration projects, or in operations and maintenance (O&M) projects.

In overseas locations where Status of Forces Agreements (SOFA), local host country technical criteria and standards, or other local circumstances conflict with the criteria in this document, alternate design approaches may be developed to achieve the intent of the criteria without compromising life safety or the safeguarding of persons and property, and must be reviewed and approved by the respective Design and Construction Agent.

### 1-3 GENERAL BUILDING REQUIREMENTS.

Comply with UFC 1-200-01, *DoD Building Code (General Building Requirements)*. UFC 1-200-01 provides applicability of model building codes and government unique criteria for typical design disciplines and building systems, as well as for accessibility, antiterrorism, security, cybersecurity, high performance and sustainability requirements, and safety. Use this UFC in addition to UFC 1-200-01 and the UFCs and government criteria referenced therein. The requirements of this UFC takes precedence over conflicts between this UFC and UFC 3- Series requirements.

### 1-4 CYBERSECURITY.

All facility-related control systems (including systems separate from a utility monitoring and control system (UMCS)) must be planned, designed, acquired, executed, and

maintained in accordance with UFC 4-010-06 *Cybersecurity of Facility-Related Control Systems* and as required by individual Service Implementation Policy.

## **1-5 POLICY.**

As stated in DoD Instruction (DoDI) 6015.17, it is DoD policy to design efficient, economical, and safe facilities that sustain an effective combat force, support the DoD medical mission, and comply with the provisions of Title 10 U.S. Code (U.S.C.). Detailed instructions and procedures, which may be developed and issued by the Design and Construction Agents must be consistent with the policy statements and criteria contained herein. Projects must:

- a. Meet the current established operating requirements of the DoD Component.
- b. Provide reasonable flexibility in the design to accommodate future changes.
- c. Meet applicable Federal legislation, codes, standards, and criteria.
- d. Ensure that the Joint Commission (TJC), Accreditation Association for Ambulatory Health Care (AAAHC), or other applicable accreditations are achieved for Medical Treatment Facilities.
- e. Meet certification requirements for Centers for Disease Control and Prevention (CDC), DoD components, Association for Assessment & Accreditation of Laboratory Animal Care (AAALAC), and Biosafety in Microbiological and Biomedical Laboratories (BMBL), or other applicable entities for laboratories.
- f. Provide functional facilities at the most economical and practical life-cycle cost (LCC).
- g. Be aesthetically compatible with the local environs and published Installation Design Guideline(s).

## **1-6 FLEXIBILITY.**

Planners and designers of Military Health System (MHS) facilities must consider future growth, change, conversion, modification and expansion of the facility campus throughout the project's life cycle. These considerations should include, at a minimum, each phase of planning, design and construction, as well as future adaptation, conversion and operation of the facility.

Use the following tenets of flexibility throughout the planning and design process:

- a. Select sites and plan infrastructure with capacity for horizontal and or vertical, expansion or contraction.

- b. Ensure continuous high-performance facilities by separating building components and systems for maintenance, according to their expected technical or utility lifespan.
- c. Consider the potential impacts of future horizontal and vertical expansions on adjacent spaces, departments, chases, utilities, structure and all other important features of the facility.

## **1-7 RESPONSIBILITIES.**

Roles and responsibilities are identified in the latest editions of the following governing documents: DoDI 6015.17 *Military Health System, (MHS) Facility Portfolio Management* and DoDD 5136.13 *Defense Health Agency (DHA)*.

### **1-7.1 Defense Health Agency/Facilities Enterprise**

The Defense Health Agency/Facilities Enterprise (DHA/FE) directs program and portfolio management of the Defense Health Program (DHP) projects and facilities, and has responsibility for: (1) fiscal compliance with the Public Law that provides MILCON authorization; (2) management of financial resources for all programming, planning, design, and construction of Military Medical Facility projects; and (3) for developing appropriate investment strategies to plan, program, budget, design, construct, maintain and sustain the MHS facility inventory.

The DHA/FE has oversight responsibility for: (1) development, issuance of and adherence to Military Medical Facility criteria, guidance and standards; (2) facilities project requirements; (3) project planning; (4) project scope; (5) project cost; (6) project life cycle impacts; and (7) project initial outfitting and transition (IO&T).

### **1-7.2 Using Agency.**

The Using Agency provide clinical and functional input on all aspects of facility sizing, functional requirements, and facility-essential or critical-use requirements such as, utility, sewer, water, and operational needs, and must work in partnership with the Design and Construction Agents and DHA/FE throughout the design and construction process. These requirements must be identified at planning inception, and associated costs must be included in the Program Amount (PA).

### **1-7.3 Design and Construction Agents.**

Title 10 U.S.C. Section 2851 and DoD Directive 4270.5 assign the Design and Construction Agents for specific geographical locations. The Design and Construction Agents are responsible for execution of projects from receipt of Design Authorization (DA) through completion of the construction contract. The Design and Construction Agents must notify DHA/FE of any field decision or change request with merit, which may exceed the Public Law and which may require a Congressional cost variation notification. The Design and Construction Agents are listed below.

### **1-7.3.1 U.S. Army Corps of Engineers (USACE).**

The Headquarters USACE Program Integration Division (CEMP-II) is the primary USACE point of contact with DHA/FE and the Using Agency for non-medically specific design and construction aspects of Medical Treatment Facility projects, and is responsible for all non-medically related program management issues and resolution between DHA/FE and USACE. The USACE Medical Facilities Mandatory Center of Expertise and Standardization, Huntsville Engineering and Support Center (CEHNC-EDX), has multi-disciplinary expertise in medical design criteria, standards, and policy, and has sole USACE responsibility for oversight, decision, and technical review of medically unique aspects of Military Treatment Facility projects. USACE's geographical District Offices must closely coordinate with CEHNC-EDX for all medically specific aspects of project design, construction, management, and execution of design and construction projects located within their respective geographical regions, including quality assurance (QA) and oversight of design and construction. CEHNC-EDX is additionally responsible for determining acquisition strategy with DHA/FE, assisting USACE geographical District Offices with project-specific design instructions to supplement the Architect/Engineer Firm (A/E) Scope of Work (SOW), for interfacing with DHA/FE and the Using Agency regarding technical issues and mandatory submissions during both design and construction.

### **1-7.3.2 Naval Facilities Engineering Command Headquarters (NAVFAC HQ) Medical Facilities Design Office (MFDO).**

NAVFAC HQ MFDO is the Navy's point of contact with DHA/FE and provides the technical expertise for medical design and construction. NAVFAC HQ MFDO is the Navy's final decision-making authority regarding project management, determining project acquisition strategy, providing project-specific design instructions to supplement the A/E SOW, and for interfacing with DHA/FE on determining project acquisition strategy, technical issues, and mandatory submissions during both design and construction, technical guidance, criteria, and standards on all Military Medical Facility projects, from initiation of project to beneficial occupancy.

### **1-7.3.3 Air Force Civil Engineer Center (AFCEC).**

AFCEC is the primary point of contact with DHA/FE for all Military Medical Facilities design and construction projects in the United Kingdom and provides project management, technical reviews, and guidance for the Air Force.

### **1-7.3.4 Supplemental Technical Criteria.**

The Design and Construction Agent(s) may maintain supplemental technical criteria to execute their organization's established design and construction regulations and procedures. Design and Construction Agents must produce designs for a complete and usable facility within the DHA/FE approved programmed scope and PA.



**1-8 WAIVERS OR EXEMPTIONS TO THIS DOCUMENT.**

Requests for project-specific waivers or exemptions to any portion of this document must be submitted in accordance with MIL-STD-3007, in writing through the Design and Construction Agent and must be fully coordinated with DHA/FE and the appropriate Using Agency. Final approval must be in accordance with MIL-STD-3007.

The TJC must approve any deviation that impacts compliance with TJC's "Management of the Environment of Care" or "Life Safety" chapter of the *Comprehensive Accreditation Manual for Hospitals*.

**1-9 GLOSSARY.**

Appendix H contains acronyms, abbreviations, and terms.

**1-10 REFERENCES.**

Appendix I contains a list of references used in this document. The publication date of the code or standard is not included in this document. Unless otherwise specified, the most recent edition of the referenced publication applies.

CANCELLED

CANCELLED

*This Page Intentionally Left Blank*

## CHAPTER 2 PREDESIGN

### 2-1 GENERAL.

This chapter and its references provide requirements for predesign information required by the Design and Construction Agents in order to execute the design of Military Medical Facilities. Predesign information includes requirements from the planning processes as defined and described in this chapter.

### 2-2 PREDESIGN PROJECT DOCUMENTATION.

Projects under consideration for budget submission must undergo additional detailed planning to include: additional project documentation; collection of relevant site and Installation specific information; and development of other guidance essential for subsequent project design. DHA/FE and Using Agency must jointly prepare this information that must be used by the Design and Construction Agent as the basis of design. Within 30 days of initial project Design Authorization (DA) release, this information/documentation must be submitted electronically to the Design and Construction Agent and DHA/FE.

#### 2-2.1 Documents Prior to DA.

Prior to release of the initial project DA, DHA/FE in coordination with the Using Agency must update and prepare this basic project documentation.

#### 2-2.2 Program For Design (PFD) and Project Room Contents (PRC).

DHA/FE in coordination with the Using Agency must develop the PFD facility space allocation and PRC requirements for installed equipment and furniture at an individual room level.

#### 2-2.3 Existing Facilities Surveys.

The Using Agency will provide facility deficiency tabulations and upgrade surveys. The Using Agency will provide the DHA/FE and its Design and Construction Agent with an updated Deficiency Tabulation Report and updated estimate of costs to correct the deficiencies to establish the requirements in support of facility alteration projects.

#### 2-2.4 Site Information.

For additions and new facilities, DHA/FE in coordination with the Using Agency will provide a completed Site Checklist as a project document. Sites with known contamination must not be considered, unless no other siting options are available. The completed Site Checklist must reference or include Installation master plans for the specific site under consideration for development.

Site information collected for project design must be comprehensive and used to avoid site-related scope and cost impacts during construction. As applicable to a project, this information includes:

- a. Area maps: location and site maps (including grades, access control points)
- b. Description of existing site condition including previous use and contamination potential
- c. The statement regarding the facility's contingency-mode or mission assurance status and related additional sustained operations requirements
- d. Specific Installation requirements or restrictions, style of architecture, construction season limitations, seismic, wind, and snow considerations
- e. SOFA or other local host country agreements or criteria
- f. Soil and foundation conditions
- g. Utility distribution
- h. Site restrictions, e.g., Air Installations Compatible Use Zones (AICUZ), potential helipad approach/departure zone obstructions, flood plain, rights-of-way
- i. Site security restrictions
- j. The National Capital Planning Commission (NCPC) requirements

#### **2-2.4.1 Utility Availability.**

The site information must include a discussion of utility availability including water, sewage, storm drainage, electrical power, communications systems, existing fuel sources, and central heat or chilled water systems, including the tap-in locations. It must also include the available capacities, power service characteristics and locations, electrical distribution, water and wastewater needs or considerations, and the Using Agency's intention, if any, for future expansion/construction of these services.

#### **2-2.5 National Environmental Policy Act (NEPA) Documentation.**

If completed, provide a copy of the appropriate level of NEPA documentation as required by the NEPA, or host-nation equivalents for projects outside of the United States. If not completed, provide a plan and timeline for completion, in accordance with requirements of the NEPA.

#### **2-2.6 Force Protection/Security Requirements.**

The project documentation must include a situation report based on consideration of all applicable threat levels. Reference UFC 4-010-06 for force protection and security requirements.

### **2-2.7 Mission Essential Facilities and Related Requirements.**

If a project facility is identified by the hosting Installation as 'mission essential,' the Using Agency and DHA/FE will coordinate project requirements with the hosting Installation Command. During planning, it must be determined which operations within the facility need to be maintained, and to what extent, under a range of risk situations. The conclusions of this assessment must be documented in the project planning assumptions. Any added facility scope and cost related to 'mission essential' status must be included in the development of the project DD Form 1391.

### **2-2.8 Contingency Mode CONOPS (where applicable).**

During healthcare requirements identification and facility requirements planning, the Using Agency must define contingency operations and requirements in a contingency mode CONOPS. In addition to operational changes required to accommodate increased workload and levels of patient care, strategies to maintain operations over a stated period of time must be clearly stipulated. The impact on patient and staff access, utility services, emergency power availability, water supply, and sewer service must be assessed and included as design requirements.

The project documentation (both Strategic Facility and Design CONOPS) must address medical mobilization expansion requirements where such temporary measures are included in the contingency mode of operations.

### **2-2.9 Fire Protection Considerations.**

Fire protection considerations for alteration projects must be based on a completed Life Safety Assessment (LSA) as described in Chapter 14 Fire Protection and Life Safety. In situations involving alteration or additions, the limitations of work in the existing areas of the facility must be determined and specifically addressed in the project DD Form 1391. Consideration of fire department access, supervision of protected premises, and fire service water supply must also be addressed.

### **2-2.10 Communications.**

Project documentation must include a description of all required systems covered in Chapter 12 Communications to a level enabling development of a programmatic cost estimate. The infrastructure for various digital radiography technologies must be assessed and addressed. An Information System Cost Estimate (ISCE) must be included in DD Form 1391 development.

### **2-2.11 Commissioning.**

Project documentation must include a description of the commissioning requirements for the project as covered in Chapter 19 Commissioning to a level enabling development of a programmatic cost estimate. During planning, the Using Agency must anticipate a requirement for commissioning based on facility and project type and include commissioning in the Budget-Ready DD Form 1391. As applicable,

commissioning costs must be estimated during planning using DoD facility cost guidance.

### **2-2.12 Parking Requirement Calculation.**

DHA/FE in coordination with the Using Agency must calculate and report the number of parking spaces required consistent with the calculation method described in Appendix G Parking Requirements and, if applicable, the scope for any structured parking, including the number of spaces and, where limited by known site restriction, the estimated number of floors (levels) above grade.

### **2-2.13 Addition-Alteration Facility Information.**

For addition or alternation projects, information must be provided on the type and characteristics of the existing construction, size of the facility, condition of utilities and services, existence of code or safety issues, and descriptions of previous alterations or additions of significance.

### **2-2.14 Safety Risk Assessment (SRA)**

As a component of predesign project documentation, an initial project-specific patient and staff SRA must be conducted by DHA/FE and the Using Agency. The project-specific SRA must be utilized to determine which design strategies are appropriate for the type of facility, and for incorporation in the project design. See Chapter 3 Design for SRA process requirements.

## **2-3 SCOPE AND COST CONSIDERATIONS.**

During planning, DHA/FE will be comprehensive in anticipating and considering scope and costs resulting from conditions that are applicable to a project. These scope and cost considerations may be based on specific studies or based on typical facility and project types. The scope and costs of such items or conditions must be estimated in the planning DD Form 1391 using DoD facility cost guidance.

### **2-3.1 Improvement/Alteration/Additions.**

The criteria contained herein are not to be used as the sole justification for any addition, alteration, or improvement to an existing facility. These criteria define requirements that must be met when improvement or alterations of existing facilities, or sub-portions or systems thereof, are specifically authorized by reference in the project document, and justified during the above described programming and planning processes.

#### **2-3.1.1 Levels of Facility Alteration.**

All costs associated with projects containing altered areas (including the cost of temporary structures if required), LCCs, and other cost impacts must be categorized according to the following definitions:

#### **2-3.1.1.1 Level 1**

Level 1 alterations include minor partition layout changes, new finishes, minor casework and equipment changes, minor modifications to HVAC distribution systems, and minor electrical branch circuit changes. The estimated cost of Level 1 alterations should not exceed 30 percent of replacement cost for the facility.

#### **2-3.1.1.2 Level 2**

Level 2 alterations include Level 1 changes, minor to major partition layout changes with associated modifications to the HVAC distribution systems and electrical power and light requirements, minor structural modifications, new plumbing fixtures, allowances for roof repair, and changes in mechanical system insulation when asbestos is present. The estimated cost of Level 2 alterations should not exceed 50 percent of replacement cost for the facility.

#### **2-3.1.1.3 Level 3**

Level 3 alterations include Level 1 and 2 changes, gutting of the building to structural frame without demolishing floors, exterior walls and roof assembly, modifications to structural frame, main electrical distribution system, air handling units (AHUs) and auxiliary equipment, plumbing system, and energy plant. The estimated cost of Level 3 alterations should not exceed 75 percent of replacement cost for the facility.

#### **2-3.1.2 Cost of Alteration.**

When proposed alteration project costs exceed 75 percent of the replacement cost for a facility, and when total facility replacement is feasible, selection of the total facility replacement option must be required.

#### **2-3.2 Site Investigation.**

DHA/FE in coordination with the Using Agency must be responsible for all investigations of facilities and sites required to generate assumptions for planning and programming. Investigations may include, but are not limited to, inspection of concealed spaces, e.g., above-ceiling areas, chases, equipment rooms, and other reasonably accessible spaces to permit evaluation and accurate depiction of as-built conditions.

#### **2-3.3 Interstitial Building System (IBS).**

In projects where IBS design concepts are under consideration as part of the base scope of the project, the scope and cost of IBS design concepts must be included as a separate line item in the DD Form 1391 and later updated in the project DD Form 1391. See Appendix E Interstitial Building System, for IBS criteria.

#### **2-3.4 Parking Facilities.**

The scope and estimated cost of parking provisions, surface or structured, must be determined during planning and included in the DD Form 1391. Cost of structured

parking must be included as a separate DD Form 1391 line item. DHA/FE is the sole Approving Authority over DoDM Military Facility parking requirements. The MHS parking policies and the standards for calculating parking requirements are located in Appendix G Parking Requirements.

### **2-3.5 Future Expansion.**

Consideration for future expansion must be incorporated into planning for all projects. Consider external and internal expansion of vital functions such as ancillary and utility services. Building site, vehicular access, structural systems, departmental adjacencies, functional layouts within departments, and utility type and source all play major roles in developing an economically expandable design. Provision for future expansion is authorized when approved by DHA/FE. The scope and cost of approved expansion capability must be included as a separate line item in the project DD Form 1391.

### **2-3.6 Special Environmental Conditions.**

Consideration must be given to water requirements for the facility, including availability and capacity of Installation water treatment facilities. Identify Installation or environmental remediation requirements, if any, beyond those described in this document during the initial planning phase of the project, and adequately program associated costs into the budget for the project.

### **2-3.7 Emergency Electrical Supply.**

Consideration must be given regarding emergency electrical supply and availability. Identify Installation requirements, if any, beyond those described in this document during the initial planning phase of the project, and adequately program associated costs into the budget for the project. Give consideration to additional supply and availability requirements pursuant to determination of: reliability of power supply; facility Mission Assurance status; and special contingency mode CONOPS. Reference Chapter 11 Electrical.

### **2-3.8 Antiterrorism/Force Protection (AT/FP).**

Identify scope impact during the initial planning phase and adequately program associated costs into the budget for the project.

### **2-3.9 Demolition of Vacated Facilities.**

DHA/FE in coordination with the Using Agency must provide a descriptive plan for the disposition of vacated facilities as part of the project planning package and adequately program associated costs into the budget for the project.

### **2-3.10 Sustainability Considerations.**

The scope and cost of sustainable design features must be developed during the planning stage and included in DD Form 1391 (reference Chapter 4 Sustainable Design Principles).



**2-3.11 Special Studies.**

Include special scope and cost considerations resulting from special facility studies performed prior to design where required or applicable for:

- a. Material Handling and Transportation (reference Chapter 16 Transportation and Logistics)
- b. Food Service (reference Appendix F Food Service)
- c. Temporary facilities planned for occupancy during construction

CANCELLED

*This Page Intentionally Left Blank*

CANCELLED

## CHAPTER 3 DESIGN

### 3-1 GENERAL.

This chapter defines DHA/FE requirements for design procedures, submittals, and documentation. The Design and Construction Agent(s) may establish additional or fewer project-specific requirements in coordination with the Using Agency(s) to meet specific project requirements.

### 3-2 DESIGN CODES AND CRITERIA.

All DoD facilities must comply with UFC 1-200-01. Refer to UFC 1-200-01 for the effective dates for UFCs, codes and criteria. When scope, cost, and schedule permit, the Design and Construction Agent may include new or updated codes and criteria.

### 3-3 DESIGN PARAMETERS.

#### 3-3.1 Scope and Cost.

##### 3-3.1.1 Documentation

During Concept Design (0–35 percent) or RFP development, the A/E must produce documentation that meets project requirements and complies with criteria while establishing final project scope and an appropriate PA, Design Directive Amount (DDA), or both.

##### 3-3.1.2 Changes

For projects submitted in the President's Budget or projects with funds appropriated by Congress, the project scope and cost are as stated on the submitted or enacted DD Form 1391. Cost and scope changes to these projects must be processed in accordance with Title 10 U.S.C. Section 2853 by DHA/FE. For projects not yet submitted in the President's Budget, there is some flexibility to adjust scope and cost. The degree of flexibility varies with the level of design. Project scope is locked for DBB projects with the 20 percent deliverable and for DB projects with the draft RFP. Project cost is locked for DBB and other delivery method projects with the 35 percent deliverable, and for DB projects with the final RFP.

##### 3-3.1.3 Added project

In the event a project is added to the MILCON program by Congressional insert, the project scope, cost, and criteria are locked when the DD Form 1391 is submitted to Congress.

##### 3-3.1.4 Functional changes during design.

The most cost effective time to address functional requirements is during the 20 percent and 35 percent design development process. Functional changes must be addressed not later than the 35 percent design. Changes to the functional design after 35 percent

design dramatically increase cost with redesign work and possibly construction modifications. After the 35 percent design is approved, functional changes must be submitted as a user change request with justification to DHA/FE for approval.

**3-3.2 Gross Building Area Calculation.**

Gross area accounting rules are illustrated in Table 3-1 and Figure 3-1. Gross area tabulation is the square footage measurement used on the project DD Form 1391. The gross area documentation requires calculation of the building gross floor area illustrated with small scale, single-line dimensioned drawings as demonstrated in Figure 3-1. The gross area includes the total area of all floors with a floor-to-clear height of 7 feet or greater, including those building features listed in Table 3-1. Gross area is measured from the outer-most exterior surfaces of all enclosing walls. The instructions in Figure 3-1 must be used to calculate the gross building area.

**3-3.3 Departmental Building Area Calculation.**

Departmental gross area calculations are illustrated in Figure 3-2. Departmental tabulation is the square footage measurement associated with the Two-Step Method in the “DoD Space Planning Criteria Chapter 130: NTG Conversion Factors”. The Two-Step Method calls for allocating the building gross area between the various departments shown in the project Program for Design and overall building common areas not assigned to a specific department. The gross area rules of Table 3-1 and Figure 3-1 must apply to departmental tabulation. The instructions in Figure 3-2 must be used to calculate the departmental gross areas. A single line diagram must be provided with the design deliverable to clearly convey how the building gross area was proportioned.

**Table 3-1 Gross Area Accounting Rules**

Building/ Project Feature	Primary/ Supporting Facility Cost	Include in Building Gross Area (DD Form 1391)	Full or Half Area	Comment	Include in Gross Area on Property Record Card (DD Form 1354)
Departmental Scope	Primary	Yes	Full	Included in PFD. Refer to Figure 3-1 Areas A & B	Yes
Walls and Partitions	Primary	Yes	Full	Included in departmental gross and circulation grossing factor. Refer to Figure 3-1 Areas A & B	Yes

Building/ Project Feature	Primary/ Supporting Facility Cost	Include in Building Gross Area (DD Form 1391)	Full or Half Area	Comment	Include in Gross Area on Property Record Card (DD Form 1354)
Ambulance Garage	Primary	No	Full	Authorized when included as separate line on DD Form 1391	Yes
Ambulance Shelter	Primary	No	Half	Authorized when included as separate line on DD Form 1391	Yes
Atrium	Primary	Yes	Full	Included in circulation grossing factor. Count only floor area. Refer to Figure 3-1 Area E	Yes
Attic or Roof Sloping Space	Primary	No	N/A	Unoccupied space only	No
Circulation					
Building Circulation	Primary	Yes	Full	Included in circulation grossing factor. Refer to Figure 3-1 Areas A & B	Yes
Vertical Circulation (elevator shaft, interior stairwells, escalators, lifts, and trash chutes)	Primary	Yes	Full	Included in circulation grossing factor. Count only at one floor in gross area. Net area on subsequent floors must not be included. Refer to Figure 3-1 Area D	Yes

Building/ Project Feature	Primary/ Supporting Facility Cost	Include in Building Gross Area (DD Form 1391)	Full or Half Area	Comment	Include in Gross Area on Property Record Card (DD Form 1354)
Exterior Open Stairs	Primary	Yes	Half	Included in circulation grossing factor. Count only at one floor in gross area. Net area on subsequent floors must not be included. Refer to Figure 3-1 Area D	Yes
Alcove	Primary	No	N/A	Refer to Figure 3-1 Area F	No
Attached Covered but Not Enclosed Walks, Passageways, Ramps, and Canopies	Primary	No	Half	Tabulate scope separately for DD Form 1354	Yes
Unattached Covered but Not Enclosed Walks, Passageways, Ramps, and Canopies	Supporting	No	Half	Tabulate scope separately for DD Form 1354	No
Unattached Roof Overhangs, Soffits for Weather Protection	Supporting	No	N/A		No
Crawl Space	Primary	No	N/A	Unoccupied space only	No
Loading Dock/Logistics					

Building/ Project Feature	Primary/ Supporting Facility Cost	Include in Building Gross Area (DD Form 1391)	Full or Half Area	Comment	Include in Gross Area on Property Record Card (DD Form 1354)
Enclosed Loading Dock	Primary	Yes	Full	Authorized when included on PFD. Refer to Figure 3-1 Areas A & B	Yes
Unenclosed Loading Dock	Supporting	No	Half	Tabulate scope separately for DD Form 1354. Refer to Figure 3-1 Area F	Yes
<b>Mechanical/Electrical/Communications</b>					
Mechanical Space	Primary	Yes	Full	Included in mechanical grossing factor. Refer to Figure 3-1 Areas A & B	Yes
Electrical Space	Primary	Yes	Full	Included in electrical grossing factor. Refer to Figure 3-1 Areas A & B	Yes
Telecommunic ation Room (TR)	Primary	Yes	Full	Included in electrical grossing factor. Refer to Figure 3-1 Areas A & B	Yes
Enclosed Building Connectors	Primary	Yes	Full	Include in Building Gross Square Feet	Yes
Interstitial Space	Primary	No	Full	Authorized when included as separate line on DD Form 1391 and Life-Cycle Cost justified	Yes

Building/ Project Feature	Primary/ Supporting Facility Cost	Include in Building Gross Area (DD Form 1391)	Full or Half Area	Comment	Include in Gross Area on Property Record Card (DD Form 1354)
Penthouse	Primary	Yes	Full	Included in mechanical grossing factor	Yes
Mezzanines or Platform for Stacking of Logistical Storage and Mechanical Equipment	Primary	No	Full	Tabulate scope separately for DD Form 1354	No
Roof Top Equipment	Primary	No	Full	Unoccupied space	Full
Roof Top Equipment Maintenance Vestibule with Over 7 Foot Clear	Primary	Yes	Full	Manufacture enclosure integral with equipment for maintenance personnel	Full
Roof Top Equipment Maintenance Vestibule with Under 7 foot Clear	Primary	No	N/A	Manufacture enclosure integral with equipment for maintenance personnel	Full
Pad Mounted Equipment	Support	No	N/A		Yes



Building/ Project Feature	Primary/ Supporting Facility Cost	Include in Building Gross Area (DD Form 1391)	Full or Half Area	Comment	Include in Gross Area on Property Record Card (DD Form 1354)
Mechanical and Utility Shafts Connecting Two or More Floors	Primary	Yes	Full	Included in mechanical/electrical grossing factor. Count only at one floor in gross area. Net area on subsequent floors must not be included. Refer to Figure 3-1 Area G	Yes
Central Utility Plant	Primary	No	Full	Tabulate scope separately for DD Form 1354 when authorized as separate line on DD Form 1391	No
Internal Pump and Utility Rooms (e.g. fire pump, bottle gas storage)	Primary	Yes	Full	Fire pump room is included in mechanical grossing factor. Other rooms may be included unless specifically included in a department within the PFD, whereas bottle gas storage is included in departmental scope	Yes
External Pump House and Utility Buildings (e.g. sewage lift station)	Supporting	No	Full	Tabulate scope separately for DD Form 1354	No
Utility Tunnels	Supporting	No	N/A		No

Building/ Project Feature	Primary/ Supporting Facility Cost	Include in Building Gross Area (DD Form 1391)	Full or Half Area	Comment	Include in Gross Area on Property Record Card (DD Form 1354)
Equipment Yards	Supporting	No	N/A		No
Other					
Exterior Balconies	Primary	Yes	Half	Tabulate scope separately for DD Form 1354. Refer to Figure 3-1 Area C	Yes
Exterior Sun Shades	Primary	No	N/A		No
Courtyard	Supporting	No	N/A		Yes
Exterior Ramp, Stoops, and Pads	Supporting	No	N/A		No
Attached Roof Overhangs, Soffits for Weather Protection	Primary	No	N/A		No
Green Roof and Roof Top Healing Gardens and Unenclosed Roof Terraces	Supporting	No	N/A		No
Smoking Shelters	N/A	N/A	N/A	Not authorized	No

Figure 3-1 Instructions for Preparing Gross Area Tabulation

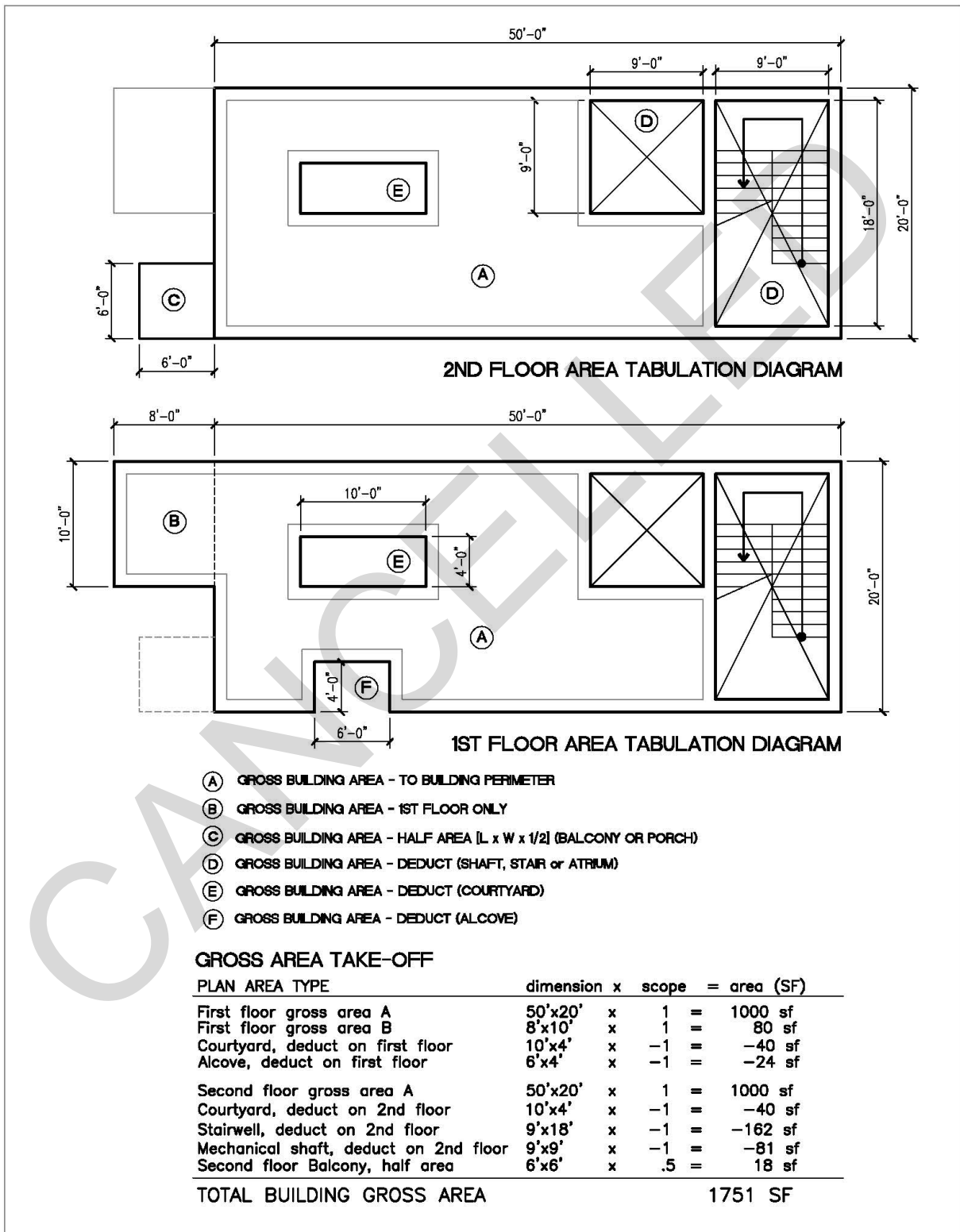

### **3-3.3.2 Measuring instructions**

#### **3-3.3.2.1 Terms**

This chapter uses Net Square Feet (NSF), Departmental Gross Square Feet (DGSF), and Building Gross Square Feet (BGSF) as defined in the glossary.

#### **3-3.3.2.2 Departments**

Space and Equipment Planning System (SEPS) provides Net Area for specific rooms in a facility. Rooms are grouped into individual departments, such as Physical Therapy, Pharmacy and Common Areas. Some rooms in individual departments are not intended to be co-located, and may be located outside of the general department area. Specific common area rooms, intended to be distributed throughout the facility, are combined in the Common Areas Department.

#### **3-3.3.2.3 Departmental grossing factor**

SEPS applies a unique departmental grossing factor to departmental NSF to determine DGSF, which includes area of the rooms defined in the individual department, internal circulation and interior walls/partitions. DGSF includes half of the wall thickness between other departments, but does not include exterior walls.

#### **3-3.3.2.4 Building grossing factor**

SEPS applies a building grossing factor to the sum of all DGSFs to determine the BGSF. The BGSF includes all areas within the exterior skin of the building according to the gross area rules of Table 3-1 and Figure 3-1. It includes all departmental areas and areas not specifically defined in the PFD, such as public corridors, building circulation, atria, walls/partitions, mechanical and electrical spaces, vertical circulation and shafts.

#### **3-3.3.2.5 Common area rules**

Departmental and Building Common Area rules are defined in Figure 3-2. The following are additional examples and rules.

- a. Pro-rating example for shared room: Department A Waiting area is defined as 100 NSF and Department B Waiting area is defined as 50 NSF in the PFD. The as designed waiting area is 120 NSF. The pro-rated areas for Department A Waiting is  $120 \times (100/150) = 80$  NSF and Department B Waiting is  $120 \times (50/150) = 40$  NSF.
- b. For facilities that have multiple CATCODES specified in the project 1391: Dedicated Building Common Areas must be assigned to the respective CATCODE. Shared Building Common Areas must be prorated to each CATCODE at the designer's discretion, with the basis for pro-rating used to determine the appropriate accounting of area to CATCODE being provided.

**Figure 3-2 Instructions for Preparing Departmental Gross Area Calculations**

**Notes for Figure 3-2**

- 1) Individual departmental gross area includes individual rooms in a department, corridors and walls within a departmental area, and half of the common wall shared with other departments and/or building common areas.
- 2) Shared walls between departments and/or building common areas shall be measured from the centerline of the wall.
- 3) For areas without partitions such as waiting areas, use the assigned floor area of the furniture seating area, or building feature (i.e. change in flooring or ceiling).
- 4) For rooms that are shared by multiple departments, pro-rate the area based on the individual departmental PFD areas that are combined.
- 5) For corridors that feed two or more rooms from two departments, assign half of the corridor to each department. For single rooms from a different department, the corridor will be assigned to the larger department.
- 6) The Common Areas Department includes telecommunication rooms, janitor closets, public toilets and other common rooms as identified on the PFD. These distributed areas shall be reported on the Net Area Tabulation sheet back to the Common Areas Department rather than the department where they are located on the floor plate.



### **3-3.4 Design to Cost.**

During the final design phase (35 percent through 100 percent design completion) for DBB projects, the A/E must produce a set of construction documents within the PA, DDA, or both, established at Concept Design approval. If design requirements or refinements cause the estimated project cost to exceed the established PA or DDA, the Design and Construction Agent with participation of the Using Agency must present cost adjustment or reduction alternatives to DHA/FE before completing the design documents.

For DB projects, cost is established at construction contract award. No cost updates are required to DHA/FE post construction award.

### **3-4 DESIGN SEQUENCE AND RESPONSIBILITIES.**

Detailed design sequence, submittals, and documentation are provided in Appendix C.

#### **3-4.1 Title 10 U.S.C. Section 2807 Action.**

The Design and Construction Agent is responsible for providing the estimated A/E design contract and other design costs and schedule to DHA/FE for inclusion in Block 12 supplemental data on DD Form 1391. Using this estimate, DHA/FE will determine if a project requires notification to Congress in accordance with Title 10 U.S.C. Section 2807. DHA/FE personnel must notify the Design and Construction Agent when the notification letters have been signed and the date after which the contract can be awarded, and forward copies to the appropriate personnel. The Design and Construction Agent is required to strictly adhere to the statute and not obligate funds for design until the 14-day Section 2807 waiting period has expired.

#### **3-4.2 Design Authorization (DA).**

DHA/FE will issue the DA to the Design and Construction Agent and provide an informational copy to the Using Agency as appropriate to meet design and programming milestones. The Design and Construction Agent must manage design in accordance with established policies and procedures unless otherwise coordinated with the Using Agency and DHA/FE. The Design and Construction Agent must not pursue any level of design beyond that authorized by DHA/FE.

#### **3-4.3 Authorization to Advertise Construction.**

The Design and Construction Agent must provide a CWE worksheet and the final design or RFP to DHA/FE to request authorization to advertise the construction contract. Bid options must be clearly delineated on the CWE worksheet. DHA/FE will notify the Design and Construction Agent and the Using Agency when the project is approved for advertising.

#### **3-4.4 Authorization to Award Construction.**

The Design and Construction Agent must provide a CWE worksheet based on the latest construction estimate and bid results, accepted bid options, and other information DHA/FE requires when Title 10 U.S.C. Section 2853 notification is required. When Title 10 U.S.C. Section 2853 action is complete, DHA/FE will notify the Design and Construction Agent and the Using Agency that the project is approved for award.

### **3-5 REVIEW OF DESIGN DELIVERABLES, ROLES AND RESPONSIBILITIES**

#### **3-5.1 Design and Construction Agent.**

The Design and Construction Agent is responsible for executing the AE and contractor's contract. They are also responsible for the overall design development, review of all design deliverables for contract compliance in accordance with codes, criteria; project design is in accordance with authorized project scope, cost, and schedule; the design incorporates best value design and construction practices; reviews for constructability; cost schedule risk analysis and mitigating strategies; development and review construction contract documents in accordance with approved acquisition strategy; incorporated accepted design review comments, ensures the designer complied with the approved quality control practices, and practices good stewardship of Government resources.

#### **3-5.2 Installation Manager.**

The Installation Manager is responsible for reviewing design deliverables for compliance with environmental requirements (NEPA), storm water management, and various permits; meeting the intent of the Installation master plan and exterior architectural standards; connection to the existing infrastructure and maintainability of the infrastructure utility systems; Installation force protection, traffic, fire protection, security standards; and real property transfer (DD Form 1354).

#### **3-5.3 Using Agency.**

The Using Agency is responsible for reviewing design deliverables for functional requirements (spaces, contents, finishes, departmental adjacencies, ability to support the flow of patients and logistics within facility and its compliance with the design concept of operations) to meet the medical program requirements; maintainability of the design solution; utility connection for medical equipment and suitability for initial outfitting. They are also responsible for the IO&T of the facilities. They may comment on other aspects of the design deliverables.

#### **3-5.4 DHA/FE.**

DHA/FE is responsible for reviewing design deliverables for meeting project planning requirements, clarification of medical unique criteria; making notifications to Congress when design deviates from prior notifications; reviewing the design deliverables for

compliance with the DD form 1391 and, project scope, criteria, and schedule. They may comment on other aspects of the design deliverables.

### **3-6 REPORTING REQUIREMENTS.**

The Design and Construction Agent must report project data as required in the Title 10 U.S.C. Section 2851 Monthly Report. The Monthly Report is due to DHA/FE no later than the tenth calendar day of each month.

### **3-7 DESIGN CONSIDERATIONS.**

#### **3-7.1 General.**

All design elements, including functional, architectural, electrical, energy, fire protection, mechanical, structural, Safety Risk Assessment (SRA), and other features, must be coordinated.

##### **3-7.1.1 Dedicated Administrative Area.**

If approved by the Design and Construction Agent and Using Agency, administrative buildings and separate administrative suites (no internal spaces will be considered), which are not intended to flex into clinical (refer to CONOPS) should use the technical requirements of UFC 1-200-01 General Building Requirements and not additional requirements of this UFC (cable trays, plenum returns, etc.).

##### **3-7.1.2 Interstitial Building System (IBS).**

DHA/FE approval for the use of IBS design, and whether the DoD system module or alternate non-DoD system module concept design is used, must be made no later than the 20 percent submission and must include consideration of the required economic comparison with conventional design. See Appendix E Interstitial Building System for IBS criteria.

##### **3-7.1.3 Safety.**

The Designer of Record must follow the concepts from the most current ANSI/ASSP Z590.3: Prevention through Design Guidelines for Addressing Occupational Hazards and Risks in Design and Redesign Processes. Through the application of Prevention through Design concepts, decisions pertaining to occupational hazards and risks can be incorporated into the process of design and redesign of work premises, tools, equipment, machinery, substances, and work processes including their construction, manufacture, use, maintenance, and ultimate disposal or reuse. This standard also provides guidance for a life-cycle assessment and design model that balances environmental and occupational safety and health goals over the life span of a facility, process, or product.

All DoD facilities must comply with DoDI 6055.01 and applicable Occupational Safety and Health Administration (OSHA) safety and health standards.



#### **3-7.1.4 Equipment Room Locations.**

DHA/FE's preference is to locate mechanical, and electrical equipment rooms with exterior at grade access. Major equipment rooms must have exterior access with paved surfaces for wheeled transport of equipment. Provide horizontal and vertical access to interior, below-grade, or upper-level equipment rooms including transport of the largest items of equipment that may require replacement. Equipment rooms must be designed so the largest serviceable part of equipment can be transported in/out of the building. This includes transporting the equipment without voiding warranties or reducing the end-state performance of the equipment.

#### **3-7.1.5 Distribution Equipment Space Clearances.**

Provide the greater of manufacturer recommended maintenance and design criteria clearances in accordance with Chapter 9 Plumbing and Medical Gases, Chapter 10 Heating, Ventilation and Air Conditioning, Chapter 11 Electrical and Chapter 12 Communications.

#### **3-7.1.6 Utility Distribution Considerations.**

Locate service isolation and balancing devices and terminal equipment that require periodic inspection or maintenance above corridors.

#### **3-7.2 World-Class Checklist.**

A project-specific checklist must be developed and provided in accordance with Appendix C Design Submittals and Documentation. If the designer of record is unable to incorporate a mandatory feature, justification must be included in the 35 percent design submittal.

#### **3-7.3 Concepts of Operation (CONOPS).**

During concept design, the Design CONOPS is finalized by the Project Delivery Team. This document provides a departmental and area-specific narrative and graphic that documents what functions the organization envisions inside a facility as well as how those functions operate. It is a concise but detailed description of the projected operation of the facility that pulls together information concerning the mission and organizational purpose, types of services being performed, and patient and staff "flow" throughout the spaces. It may include the functional description of the spaces, special requirements specific to those spaces, and adjacency requirements within and among the various departments and clinics. The document depicts the routine, daily actions of staff and patients, the flow of supplies, the use of equipment and all other pertinent functions within the building. For DB projects, the designer preparing the RFP documents may assist in the CONOPS development and ensure the RFP documents are coordinated with the CONOPS. For DBB projects, the designer of record must assist in development, and document the discussions in the Functional Concept Manual (FCM). (Refer to Appendix C Design Submittals and Documentation.)

### **3-7.4 Parking.**

Patient and staff parking guidance is provided in Appendix G Parking Requirements. The amount of parking required is determined using the parking formulas provided. Design must ensure ease of patient access.

### **3-7.5 Future Expansion.**

Provide external horizontal building expansion of 20% of the enacted DD Form 1391 gross building area divided by the number of number of floors within the project unless the project requirements state otherwise. Departments most likely to be expanded or converted for future adaptation need be located adjacent to the expansion zone or internal soft spaces.

The tenets of flexibility are:

- a. Select sites wherever practicable and plan infrastructure with capacity for expansion, horizontal and or vertical, or contraction.
- b. Facilities should have the capacity for adaptation and for possible conversion to alternative use.
- c. Ensure continuous high-performance facilities by separating building components and systems for maintenance, according to their expected technical or utility lifespan.
- d. Consider the potential impacts of future horizontal and vertical expansions on adjacent spaces, departments, chases, utilities, structure and all other important features of the facility.

### **3-7.6 Alterations and Additions to Existing Facilities.**

For alteration and building addition projects, the A/E must conduct thorough investigations of existing facilities to become knowledgeable of facility conditions. The A/E must establish the existing condition and characteristics of the facilities utilities and services, systems, existence of code and life safety issues, construction type, requirements for maintaining a secure environment, and infection control as they pertain to the design, construction, and phasing of the work. These investigations and their impact on design of facility alterations and additions must be described in the project design documents.

Alterations to existing equipment and systems, including temporary connections, changes to system performance, or measures necessary to sustain service, must also be shown and described in detail in the project design documents. The A/E must evaluate the impact on existing systems where connections are made that increase overall system demand. The locations of new connections must clearly be shown, described, or both. The A/E must determine and document any project work that must necessitate a reduction or interruption of any service to an existing occupied space.

### **3-7.7 Safety Risk Assessment**

A Safety Risk Assessment (SRA) must be applied from the programming phase through construction to guide, inform and aid in incorporation of risk based safety practices into each MILCON project. The Safety Risk Assessment must be that developed by the Center for Health Design. It must be utilized to determine which design strategies are appropriate for the type of facility, and for incorporation in the proposal and design. A project-specific SRA must be submitted in accordance with Appendix C Design Submittals and Documentation. The SRA must be initiated by DHA/FE during the planning phase of the project. Management of the SRA must be the responsibility of the A/E of record as the SRA continues to evolve with additional levels of detail as needed to support the creation of a safe environment throughout the design, construction, and commissioning phases.

### **3-7.8 NFPA 99 Risk Assessment.**

A NFPA 99 Risk Assessment for Risk Category, Space Category, and Building System Category must be developed and provided in accordance with Appendix C.

### **3-8 DESIGN SUBMITTALS AND DOCUMENTATION REQUIREMENTS.**

Refer to Appendix C Design Submittals and Documentation for design submission requirements.

### **3-9 PROJECT COST ESTIMATES.**

The Design and Construction Agent must review and approve all construction cost estimates. Construction cost estimates must separate the costs by the type of appropriations.

Cost estimates for building systems developed during design must include the costs associated with providing the Real Property Installed Equipment (RPIE) and the infrastructure to support Personal Property (PP). RPIE and PP is further defined in Chapter 15 Equipment.

### **3-10 FUNDS MANAGEMENT POLICY.**

#### **3-10.1 Title 10 U.S.C. Section 2853 Action.**

The Design and Construction Agent must provide the CWE to DHA/FE with their request for authority to award a construction contract. When a project requires notification to Congress in accordance with Title 10 U.S.C. Section 2853, the Design and Construction Agent must plan for and allow at least four weeks in order to complete the Congressional Notification process prior to the desired award date. DHA/FE will notify the Design and Construction Agent when the Congressional Notification correspondence is within 14 days of being complete so that a contract award may be made.

When a project requires reprogramming action in accordance with the applicable MILCON Appropriations Act, the Design and Construction Agent should allow three months prior to the desired award date after additional funds are secured. Projects that are authorized and appropriated through non-standard MILCON funding, such as Supplemental Appropriations or Base Realignment and Closure (BRAC), may require additional notification time so the Defense Health Agency can complete unique notification and coordination requirements. DHA/FE personnel must notify the Design and Construction Agent when the notification letters have been signed, and forward copies to appropriate personnel. The Design and Construction Agent is required to strictly adhere to the statute and not obligate funds for award until the waiting period has expired.

**3-10.2 Return of Excess Funds.**

At DHA/FE's request, the Design and Construction Agent must return any cost savings (difference between project funds allocated and award CWE) to DHA/FE.

**3-11 HISTORICAL ANALYSIS GENERATOR (HAG) DATA.**

The Design and Construction Agent is responsible for loading construction contract award data into the HAG (also known as HII) database within 30 days of contract award. (Refer to the Historical Analysis Generator website.) These data are used to generate historical Guidance Unit Costs (GUCs) for publication in UFC 3-701-01, in accordance with the latest version of UFC 3-730-01.

## CHAPTER 4 SUSTAINABLE DESIGN PRINCIPLES

### 4-1 GENERAL.

This chapter supplements UFC 1-200-02 *High Performance and Sustainable Building Requirements* by describing requirements and developing uniformity specific to Military Medical Facilities.

### 4-2 DESIGN PROCESS.

The designer must analyze LCC effectiveness in support of the military medical mission, to include first cost, energy consumption, annual O&M, and other associated direct costs when evaluating sustainable design features and systems. Project Delivery Teams must prioritize sustainable features that have the highest potential for cost-effective implementation. Sustainable design elements that have been shown to be LCC-effective should not be cut from scope to reduce cost.

### 4-3 SUPPORTING DOCUMENTS.

Supporting documents include Defense Health Agency, Using Agency and Design and Construction Agent publications and regulations including sustainable design policies applicable to DoDM projects, Medical Design Instructions (MDIs), Engineering Technical Letters (ETLs), project-specific design instructions, engineering and construction bulletins, and other DoD-related criteria.

*This Page Intentionally Left Blank*

CANCELLED

## CHAPTER 5 ANTITERRORISM (AT) AND PHYSICAL SECURITY

### 5-1 GENERAL.

This chapter provides facility design criteria and guidance for antiterrorism, physical security and crime prevention. These programs are intended to protect assets: people, facilities, and equipment from terrorism and other hostile manmade threats.

### 5-2 ADDITIONAL CRITERIA.

The Planning Team uses UFC 4-020-01 DoD Security Engineering Planning Manual, to develop the security and AT requirements. UFC 4-020-01 and the multiple supporting AT UFCs referenced by UFC 4-020-01 implement the facility requirements of DoD Instruction (DoDI) 2000.16, for new and existing construction. This criteria provides minimum construction requirements that must be incorporated in inhabited new construction and major renovations projects. See additional regulatory requirements for physical security of controlled substances in 21 CFR 1301.72. AT and physical security systems required by this chapter must also comply with NFPA 101 life safety requirements.

### 5-3 DESIGN CRITERIA PLANNING TEAM.

Ensure appropriate key personnel are identified and are represented to ensure that their varied interests relating to security and AT requirements are included. The specific membership of a planning team will be based on local considerations, but the following functions must be represented; facility user, engineer, security, intelligence and Antiterrorism Officer.

### 5-4 ELECTRONIC SECURITY SYSTEMS (ESS).

#### 5-4.1 Purpose

Provide an ESS for Military Medical Facilities utilizing various combinations of capabilities for, Access Control Systems (ACS), Duress Alarm Systems (DAS), Infant Protection Alarm System (IPAS), Intrusion Detection Systems (IDS), Video Surveillance system (VSS), Behavioral Health Staff Assist Alarm and photo badging. Refer to Chapter 12 Communications for additional information and requirements for communication supporting infrastructure and interoperability.

#### 5-4.2 Systems Considerations.

ESS is an integrated electronic system that encompasses interior and exterior ACS, DAS, IPAS, IDS, VSS, BHSA Alarms. An assessment of ESS alarm systems requirements must be conducted for facilities in accordance with the project CONOPS and in coordination with the Using Agency and DHA/FE. Multiple ESS components may be integrated to provide an overall facility security system

#### **5-4.2.1 Stand-Alone Clinic Facilities Projects.**

For stand-alone clinic facilities projects provide ESS with all the capabilities identified for ACS, DAS, IDS, VSS, and BHSA as appropriate for the services noted in the project CONOPS with the exception of IPAS. Project-specific criteria must be fully coordinated with the Using Agency.

#### **5-4.2.2 Inpatient Military Medical Facilities Projects.**

For inpatient Military Medical Facility projects, provide an ESS with all of the capabilities identified herein as a turn-key system that is networked together for a totally integrated ESS for the facility. An interface with the facility Radio Page (RP) System or other wireless personal communications device must be included (reference Chapter 12 Communications, Radio Page Systems) so that alarm events can be communicated to the facility security staff (for quick response), and the facility NTS System (reference 12-5, Network Time Synchronization System).

#### **5-4.3 ESS Components and Funding Restrictions.**

Unless stated otherwise herein, the systems and equipment are funded by the construction project. The systems and equipment items listed here require Proponent funds to procure the items. The construction project can fund all infrastructure and utility support but cannot fund the purchase and installation of the equipment items listed here. Therefore, a listing for separate line-item funding and accounting is required for these items, and the Military Interdepartmental Purchase Request (MIPR) of Proponent funding to the contracting agency is required to pay for the totally integrated ESS that must be provided as a turn-key system from a single qualified ESS contractor. Refer to MIL-STD-1691 Table 6-1 Systems Planning Matrix for property type designations for the ESS System and its subcomponents.

##### **5-4.3.1 ESS: Access Control System (ACS)**

Reference UFC 4-021-02 Electronic Security Systems for components and requirements associated with the ESS: Access Control System.

##### **5-4.3.2 ESS: Duress Alarm System (DAS)**

Reference UFC 4-021-02 Electronic Security Systems and Table 4.1 for components and requirements associated with the ESS: Duress Alarm System. Reference UFC 4-510-01 Appendix A for details on the functionality and requirements associated with Duress Alarms for Medical Facilities.

This proponent-funded duress alarm equipment is not included as part of the door access control system.



### **5-4.3.3 ESS: Infant Protection Alarm System (IPAS)**

Infant Protection Alarm System is required for all Medical Facilities with Labor and Delivery Units, Obstetric Units, and Neonatal ICUs. Coordinate expansion of the IPAS to cover additional inpatient Units, as noted in 5-4.9 and per the project CONOPS.

### **5-4.3.4 ESS: Intrusion Detection System (IDS)**

Reference UFC 4-021-02 Electronic Security Systems for components and requirements associated with the ESS: Intrusion Detection System. Also reference Table 5-1 Intrusion Detection and Duress Alarm Locations and Sensor Types for intrusion detection locations and component types.

### **5-4.3.5 ESS: Video Surveillance System (VSS) Equipment**

Reference UFC 4-021-02 Electronic Security Systems for components and requirements associated with the ESS: Video Surveillance System. UFC 4-021-02 may reference this system as CCTV.

### **5-4.3.6 ESS: Behavioral Health Staff Assist (BHSA) Alarm**

Reference UFC 4-021-02 Electronic Security Systems for components and requirements associated with the ESS: Behavioral Health Staff Assist Alarm. Reference UFC 4-510-01 Appendix A for details on the functionality and requirements associated with Duress Alarms for Medical Facilities.

## **5-4.4 System Configuration and Major Functional Components.**

5-4.4.1 Major functional components include but are not limited to:

- a. ESS network
- b. Intrusion detection and alarm system
- c. Door access control system
- d. Video surveillance system
- e. Infant Protection alarm system
- f. Behavioral Health Staff Assist alarm system

5-4.4.2 Major interfaces in inpatient Military Medical Facilities include:

- a. Interface with Radio Page (RP) Systems (reference 12-11)
- b. Interface with Network Time Synchronization (NTS) System (reference 12-5)

#### **5-4.5 ESS Network.**

Provide an independent, dedicated, industry-standard network with DISA and DHA standard LAN technology, protocols, equipment, and cabling to interconnect all provided electronic security capabilities into an integrated ESS in support of facility-wide security requirements and operations. During design consider all outlying medical buildings using the Hospital ESS Network for Access Control. The facility Information System network must not be used for ESS networking:

- a. As an independent, stand-alone network, the application design must incorporate the requirements of the DHA Cybersecurity Guidance for Facility-Related Control Systems (FRCS) and Medical Device and equipment (MDE) in support of the Risk Management Framework (RMF) process outlined in Chapter 12 Communications. This must include the system network architecture, software, hardware, and security requirements.
- b. Servers and workstations must meet standardized baseline requirements and specifications as defined by DISA and DHA. Servers and workstations must utilize the most current DoD approved operating system, and must provide central databases for all of the operating systems, application programs, and data logging. In hospitals and medical centers that have an onsite Radio Page System and or other wireless networked personal communication devices, the ESS network must also provide an interface with these facility systems to communicate security events to the staff.
- c. Network Infrastructure (switches, routers, etc.) must meet the standard baseline specifications as defined by DISA and DHA. When possible, network electronics must match NiPR infrastructure for patch management and network administration.

##### **5-4.5.1 Integrator Network Major Components.**

The ESS integrator network must be configured as a Client Server network with the major components listed here to serve all of the specified capabilities:

- a. LAN and infrastructure
- b. Database servers
- c. Digital video servers
- d. System Operator Workstations
- e. Management Workstation
- f. Maintenance Workstation
- g. System software

**5-4.6 Intrusion Detection and Duress Alarm.**

**5-4.6.1 Sensors and Locations.**

Intrusion detection and duress alarm locations and sensor types are as indicated in Table 5-1. Table 5-1 is provided for guidance. Specific design must be in accordance with the project CONOPS.

**Table 5-1 Intrusion Detection and Duress Alarm Locations and Sensor Types**

<b>Location</b>	<b>Balanced Magnetic Switch</b>	<b>Motion Detector</b>	<b>Duress Alarms</b>
Inpatient and Outpatient Pharmacy	X	X	
Inpatient and Outpatient Pharmacy dispensing Window(s) and consult rooms	X	X	X
Emergency Department Reception and Nurse Station			X
Pharmacy Vault	X	X	
Food Service Account Office	X	X	X
Cashier Locations	X	X	X
Logistics Vault	X	X	
Logistics Warehouse	X	X	
Silver recovery central Collection point	X	X	
Behavioral Health			X*
Admissions Cubicles			X
Command Office			X
*This includes both inpatient and outpatient Behavioral Health settings. See Appendix A for locations of Duress Systems equipment and operational requirements in Behavioral Health settings.			

A balanced magnetic switch must be placed on each door or window that could provide access. The motion detector must cover the entire area being protected. Video surveillance monitoring and recording must be activated by the intrusion detection and duress alarms. The intrusion detection and duress capability design must follow established industry guidelines, Using Agency regulations and be coordinated with the facility and Installation security staffs.

#### **5-4.6.2 Remote Alarm Reporting.**

Any combination of intrusion or duress alarms that requires immediate military police response must be communicated to the Installation Security Office. For the implementation of this function, provide an interface to the existing Installation ESS network. The system contractor must field coordinate the exact configuration and location of this interface with the Installation Security Office.

The selection of alarms to be routed to the Installation Security Office must be under software control from the facility ESS Management Operator Workstation. The initial list of alarms to be programmed for remote reporting at the time of facility ESS activation must be coordinated with the Contracting Officer.

#### **5-4.7 Door Access Control.**

Provide electronic door access control capability, as a minimum, at the locations listed here and as required by the project-specific criteria. The capability must:

- a. Provide for addition of access authorization to CAC cards as the primary access control card; and
- b. Include photo badging equipment to produce access control cards, and a Management Workstation to issue access cards, when CAC card usage is not feasible; and
- c. Generate and maintain a listing of current authorized access by individual, location, and time; and
- d. Discontinue access authorization for issued cards. Monitor and control of door access activity and events must utilize the integrator network Workstations. Where required, provide an interface between the video surveillance and the door access control capabilities to initiate video monitoring and recording of surveillance cameras anytime these doors are opened unless an authorized access control card has been read by the card reader, or an authorized personal identification number (PIN) is entered in an access control keypad. This must be as further defined herein in 5-4.8, ESS: Video Surveillance System (VSS).

A staff identification card system with multiple levels of access control may be provided.

**5-4.7.1 Access Controlled Door Locations.**

Electronic door access control devices must, as a minimum, be provided at these locations:

- a. Selected building entrances per project-specific criteria
- b. Each exterior door to the first floor mechanical equipment rooms
- c. Each storage room entrance door
- d. Each Pharmacy door
- e. Each Pharmacy vault door
- f. Server Room Support Equipment (CMP04) door
- g. Each Cashier Office door
- h. Each Behavioral Health Unit entrance door
- i. Command suite entry door
- j. All Telecommunication Room doors
- k. Service Entrance Facility (COMC2) door and entry facility door
- l. Server Room (CMP01) door
- m. Communications Radio Equipment (COM04) door
- n. Penthouse equipment room door
- o. Each staff locker room door
- p. Inpatient Records room door
- q. Outpatient Records room door
- r. Multimedia equipment room door
- s. Security Department entry doors
- t. Medication Rooms
- u. Select elevators as directed by the Using Agency in coordination with DHA
- v. Additional locations must be as directed by the Using Agency in coordination with DHA

#### **5-4.7.2 Door Access Control Major Components.**

Reference UFC 4-021-02 Electronic Security Systems for components and requirements associated with the ESS: Access Control System. Major components of the door access control system are listed in UFC 4-021-02.

#### **5-4.8 ESS: Video Surveillance System (VSS).**

The provided video surveillance capability must perform functions for capturing, viewing, controlling, monitoring, and recording of video surveillance scenes for specified locations throughout the facility and site. Operation for monitoring and control functions for video surveillance must take place at system integrator network Operator Workstations. Where required, all images from all video cameras must be digitally recorded on video camera servers at all times. Provide as many video camera servers as are required for recording all images from all video cameras. Recording parameters must be as specified by the Using Agency and verified by the system contractor. All alarms routed over the ESS integrator network must be received and processed for automatic initiation of special video monitoring and recording protocols for the alarm event point and a designated zone associated with the alarm event point.

##### **5-4.8.1 Color Video Camera Coverage.**

Color video images of surveillance scenes from points throughout the facility and site must include but not be limited to these locations:

- a. Main Entry Lobby area
- b. Ground level Elevator Lobby area
- c. Cashier Office
- d. Cashiers locations in food service and Installation exchange
- e. Vaults
- f. Entrances and fire exits from the L&D Unit, NICU, Pediatric and Behavioral Health Units
- g. Server Room Support Equipment (CMP04) door
- h. Service Entrance Facility (COMC2) door and entry facility door
- i. Server Room (CMP01) door
- j. Communications Radio Equipment (COM04) door
- k. Emergency Waiting areas
- l. Emergency Walk-In Entrance and Reception

- m. Ambulance dock and entry area
- n. Corridors connecting buildings
- o. Pharmacy dispensing windows and Waiting Area
- p. Main and secondary building entrances and exits
- q. Service elevator lobbies
- r. Loading docks and dock dumpster areas
- s. All Parking Lot areas
- t. Inpatient Behavioral Health outdoor areas
- u. Additional locations must be as directed by the Using Agency in coordination with DHA/FE

All other locations can be covered using black and white cameras as directed by the Using Agency in coordination with DHA/FE.

#### **5-4.8.2 Video Surveillance Major Components.**

Reference UFC 4-021-02 Electronic Security Systems, Chapter 4 Closed Circuit Television Systems for components and requirements associated with the ESS: Video Surveillance System.

#### **5-4.9 ESS: Infant Protection Alarm System (IPAS).**

Provide the capability to detect and report alarms if an attempt is made to abduct an infant or pediatric patient from protected patient care areas, such as the L&D Unit, Obstetric Unit, Pediatric Unit, Med/Surg Unit when infants or pediatric patients are admitted to them, Level 1 Well Baby/Holding Nursery and Level II, III or IV Neonatal ICUs. To protect the infants or pediatric patients in these units, an interactive tag must be attached to each patient in the units. The tag must signal an alarm if there is any unauthorized attempt to remove the patient from the secured unit (exit alarm), or if there is an unauthorized removal of the tag or strap from the patient (tag tamper alarm). In an alarm condition, electromagnetic locks on exit doorways from the unit must be activated to delay or prevent the unauthorized individual from being able to leave the unit with the patient, and allow time for the staff in the area to respond to the alarm.

The system must be supervised to detect any tampering or removal of a monitoring device. Any detected unauthorized tampering with, or unauthorized removal of equipment must generate an alarm condition. All alarms must be concurrently routed in real-time to all Operator Workstations, transmitted to the security staff and staff in the alarmed unit via radio page or other wireless networked personal communication device. Operation and management of the IPAS capability must take place at Infant Protection Workstations installed in the designated Nurse Station of each unit. The

electromagnetic door locks must be interfaced with the facility fire protection system to unlock the doors in the event of a fire. Also, if there are elevators within the perimeter of a protected area, an alarm condition signal must be routed to the elevator controls to prevent the elevators from arriving in or leaving the protected unit area.

#### **5-4.9.1 Infant Protection Major Components.**

Major components to provide Infant Protection Alarm capability include but are not limited to:

- a. Network adapters
- b. Infant Protection Workstations
- c. RF readers
- d. Low frequency (LF) readers
- e. Infant tags and straps
- f. Door position switches
- g. Exit door dome lights with tone device
- h. Electromagnetic door locks and power supplies
- i. Proximity card readers
- j. Infant protection software

#### **5-4.10 ESS: Behavioral Health Staff Assist (BHSA) Alarm.**

Appendix A Behavioral Health Design describes the required functionality of the primary signaling (response managed within the unit or clinic) and secondary signaling (response by resources external to the unit or clinic) for Behavioral Health Staff Assist system.

5-4.10.1 The primary signaling capability must consist of wired and wireless components as prescribed by Appendix A Behavioral Health Design.

5-4.10.2 The secondary (external to the unit or clinic) signaling for Behavioral Health Staff Assist must consist of centrally located Duress Alarm components as prescribed by this section and by Appendix A Behavioral Health Design.

#### **5-4.11 Basic Design Requirements.**

##### **5-4.11.1 Electrical Power.**

ESS equipment in inpatient Military Medical Facilities must be powered from the essential electrical system emergency power equipment branch per Table 12-1. AC



powered equipment must be protected by either an internal battery backup or a UPS unit that must provide at least 15 minutes of full power during an AC power failure. UPS units must comply with UL 1778 and 47 CFR Part 15.

Power all video cameras from camera power supplies located in the nearest Telecommunications Room (TR).

#### **5-4.11.1.1 DoD Assessment and Authorization.**

The ESS in Military Medical Facilities must be certified in accordance with DoD Assessment and Authorization Process. This certification requires the system to have a number of security characteristics and features.

### **5-5 SPECIAL CONSIDERATIONS FOR SECURITY SENSITIVE AREAS AND ROOMS.**

Sensitive areas and rooms must be designed to store valuable assets, i.e., funds, narcotics, dangerous drugs, and controlled substances and materials. The most cost-effective method of providing adequate security for these assets must be selected.

#### **5-5.1 Safes.**

Drugs classified as Schedule I or II controlled substances under the Controlled Substance Act of 1970 must be stored in safes or vaults. Drugs classified as Schedule III–V may also be stored in safes or vaults as deemed appropriate by the Using Agency and DHA/FE.

#### **5-5.2 Vaults.**

Features to be considered for vault storage areas are outlined in 21 CFR 1301.72 and Using Agency directives.

#### **5-5.3 Pharmacies.**

Walls, floors, ceilings, doors, and service windows of pharmacies must provide resistance to forced and covert entry and, where necessary and required by DHA/FE and Using Agency physical security regulations. Doors and windows must be kept to a minimum and doors must be keyed separately from the master key system. IDS sensors must be installed at all doors and windows including windows opening to corridors. As a minimum, walls surrounding pharmacies must be constructed full height from floor slab to structure above.

##### **5-5.3.1 Doors.**

Doors must be provided with security hinges and must be locked with security locksets. Doors must be solid core wood or hollow core steel. Other considerations include “peep holes,” two way intercom system with camera, and card access system with key pad for the main staff entrance door, double-locking locksets with 1-inch throws, warning signs

stating doors must remain unlocked during normal operating hours (for fire egress), and warning signs stating “Controlled Area.”

**5-5.3.2 Windows.**

Provisions, such as roll-up shutters, must be made for securing all service windows after normal operating hours. Frames holding roll-up shutters and security screens or bars must be securely fastened with smooth-headed bolts with nuts peened in place.

**5-5.3.3 Utility Openings.**

Duct terminals and connecting points must be in exposed locations where they may be readily observed to detect tampering. Openings of 96 square inches or larger must be protected IAW MIL HDBK 1013/1.

**5-5.4 Medical Supply Storage Areas or Facilities.**

In addition to the criteria provided for pharmacies, high value, critical, and pilferable resources stored in this type of storage area or facility must be protected in accordance with specific requirements as defined by 21 CFR 1301.72, Using Agency directives and DHA/FE.

**5-5.5 Other Security Sensitive Areas and Rooms.**

Other activities or locations may be identified by the Using Agency and DHA/FE as security sensitive. These areas and rooms must minimize the security risk for these activities or locations. Package inspection devices may also be considered for mail rooms. Design ESS in accordance with UFC 4-021-02.

## CHAPTER 6 ARCHITECTURAL

### 6-1 GENERAL.

This chapter provides architectural design guidance. All Military Medical Facilities must emphasize architectural design excellence while balancing economical, functional, energy efficient, and sustainable architectural design elements. Principles of Evidence Based Design (EBD) and world-class facility standards must be included where applicable, based on project scope and building type. Designs must adhere to general healthcare industry standards, DoD and Using Agency specific functional requirements, UFC 3-101-01, and criteria specified herein.

### 6-2 EXTERNAL DESIGN.

Adhere to applicable Installation design guidance and individual Using Agency exterior design standards where applicable. Give special attention to provide convenient and Architectural Barriers Act (ABA) compliant patient access and drop off areas. Consider safety and separation of public, staff, emergency, and logistics travel paths as an integral part of the design.

### 6-3 EXTERIOR WALL DESIGN.

Energy Performance. All facilities must comply with the requirements listed in Chapter 4 Sustainable Design Principles and with any Using Agency or Design and Construction Agent directives mandating increased energy performance.

### 6-4 FENESTRATION AND WINDOWS.

Required Locations. Provide natural day lighting throughout the facility. Exterior windows must be provided in normal nursing care areas. Intensive Care and Cardiac Care bedrooms, Prosthodontic Dental Treatment Rooms (DTRs), and Prosthodontic-Ceramics Laboratories should also be provided with natural lighting or artificial lighting balanced to the natural wavelength. Natural lighting may be provided in Dermatology Clinics if required by the Using Agency. Exterior windows must also be provided per host nation requirements where it exceeds DoD criteria.

### 6-5 INTERIOR CONSTRUCTION.

#### 6-5.1 Aseptic Environments.

An Infection Control risk assessment must be developed to address risk management during the project. The risk assessment must include requirements that address patient care, facility design, construction, construction phasing, ventilation, safety, and epidemiology. Selection of interior construction and finishes must consider the need for aseptic environments. Use smooth, nonporous, seamless materials to minimize contamination and reduce housekeeping requirements. Smooth, seamless wall and floor coverings facilitate cleaning. Cabinetry should be designed and installed without gaps behind or underneath base units. At a minimum, these areas must be designed

for ease of housekeeping, with elimination of materials or surfaces that could harbor contamination and to minimize maintenance requirements:

- a. Oral Surgery Rooms, DTRs
- b. Special Procedure Rooms, e.g., Cardiac Catheterization, Angiography, Endoscopy
- c. Operating Rooms (ORs), including C-Section
- d. Emergency and Trauma Rooms
- e. Decontamination Rooms in Surgery, Delivery, and Central Processing and Distribution (CPD)
- f. Sterile Storage Rooms (Surgery, Delivery, CPD)
- g. Sub sterile and Recovery Rooms (Surgery and Delivery)
- h. All Patient Treatment Rooms
- i. Intravenous Admixture and Chemotherapy Preparation Rooms in Pharmacy

#### **6-5.2 Interior Design.**

All finished designs must comply with Appendix B Architectural and Engineering Design Requirements. Additionally, for Army projects use Army interior design guides, which represent a benchmark for quality for interior design finishes and furnishings. Army CONUS facilities, use the "HFPA/MEDCOM Interior Design Master Plan." For European facilities, use "The Environment of Care - Europe, Version V" ("ECEv"), latest edition. For Air Force projects, use the "U.S. Air Force Surgeon General/AFMS Interior Design Standards."

Patient care areas must meet the designated Program for Design (PFD) square footage requirements and must not vary more than plus or minus 10 percent without an approval from DHA/FE. This deviation should be recorded in the submittal requirements, Appendix C, specific to the net area calculations with narrative justification. Design the following rooms at "full scope" in accordance with the PFD requirement: treatment rooms, radiological rooms and dental treatment rooms. If for some compelling reason such as column placement these rooms cannot meet the full scope obtain an approval to deviate from DHA/FE in the same process as stated above.

#### **6-6 FRONT DESK LOCATION.**

For areas that regularly receive patients for care or administrative reasons, patients and users must have a clear understanding of where to go upon check-in and must be within immediate, physical reach of attendants if directional or medical assistance is required. Position the front desk to provide immediate focal point of entry into each department

and ensure that the desk attendant can have immediate, eyes on, and physical access to the patient without having to walk around walls or obscuring barriers.

## **6-7 FLOORS.**

Reference Appendix B Architectural and Engineering Design Requirements for floor finishes.

## **6-8 WALL AND PARTITION SYSTEMS.**

Reference Appendix B Architectural and Engineering Design Requirements. Provide systems that permit modification with the minimum cost and difficulty within acoustical and fire criteria, except in areas subject to severe impact. As a general rule, interior non-load bearing metal studs should be a minimum 20 gauge, 16 inches on center unless otherwise directed by the Design and Construction Agent or more stringent structural requirements apply. Provide non-combustible wall backing at all wall-hung equipment and accessories. Architectural acoustics must be coordinated across all building systems.

### **6-8.1.1 Use of Full Height Partitions.**

Full height partitions (floor to structural slab above) must be used where required to meet fire/smoke resistance and sound performance requirements and in these listed rooms, spaces, and compartments for physical security purposes:

- a. Medical Record Storage areas (paper file areas or large centralized areas), Legal, credentials, quality, and Human Resource records storage areas
- b. Materiel Services Storage areas
- c. CPD Storage areas
- d. Pharmacy
- e. Prosthodontics and Ceramic Laboratory
- f. Medical Equipment Maintenance and Repair
- g. Orthotic Appliance Manufacturing
- h. Facility Engineer Maintenance Shops
- i. Pulmonary Function and Laboratory
- j. Medical Service Account (MSA) Funds Storage
- k. Labor, Delivery, and Recovery Rooms (LDR)/Labor, Delivery, Recovery, and Postpartum Rooms (LDRPs)

- I. Corridors
- m. Neonatal Intensive Care Unit (NICU), Nurseries, and Pediatric Inpatient Rooms
- n. Behavioral Health Inpatient and Seclusion Rooms

All spaces in Appendix B with air balance requirements of “++” or “- -” (and associated anterooms) must be designed and constructed with full height room partitions, extending from floor to structural ceiling, with all joints and penetrations sealed to prevent the passage of air. Refer to 10-7.5.2 for leak test requirements for these spaces.

#### **6-8.2 Barriers.**

Design protective barrier partitions to protect occupants or equipment in rooms, spaces, and compartments from fire, smoke, radiation exposure, electrical interference, magnetic resonance imaging (MRI) shielding, or for physical security purposes.

#### **6-8.3 Protection and Safety Features.**

Use bumper guards and corner guards on all walls in patient care areas subject to frequent abrasion and impact, such as corridors, utility rooms, CPD, gurney storage, and others.

Provide handrails in corridors where patients routinely travel and public areas where travel along a wall is possible. Handrails are not necessary in administrative areas.

#### **6-8.4 Toilet Facilities.**

Provide appropriate floor slope, water containment, and drainage as required. Give consideration to slip resistant surfaces in wet areas. All thresholds must meet ABA requirements as specified in Chapter 13 Accessibility.

#### **6-8.5 Toilet Partitions.**

In locations where toilet partitions are utilized, provide ceiling hung type, unless directed otherwise by the Design and Construction Agent.

### **6-9 CEILINGS.**

#### **6-9.1 Support.**

Suspended ceiling surfaces cannot be used for the direct support of cubicle curtain tracks and ceiling lights. Ceiling-mounted accessories must be secured through the ceiling to secondary support members.

## **6-9.2 Utility Access.**

Provide maximum accessibility in corridor ceilings to the mechanical, electrical, plumbing and telecommunication distribution systems. Do not use concealed-spline ceiling systems requiring special tools to lower tile assemblies. Identify the access panels into ceiling plenums in order to identify the type of utility present and coordinate with all disciplines.

## **6-10 VESTIBULES.**

Provide exterior vestibules at primary patient entrances. Vestibules must comply with ABA requirements and should be of sufficient depth to allow the outside doors to close before the inside doors are opened. The Design and Construction Agent may waive this requirement in moderate climates if justification concerning energy and life cycle cost are provided.

## **6-11 DOORS.**

### **6-11.1 Automatic Doors.**

Electrically operated or hydraulically operated automatic doors must be provided for Emergency Trauma entrances and primary patient entrances of MTFs.

### **6-11.2 Doors, Frames, and Hardware.**

Door sizes and types are as indicated in Appendix B Architectural and Engineering Design Requirements. Unless otherwise stipulated by the Design and Construction Agent, all door frames must be hollow metal. Label doors and door frames for appropriate fire rating. Door hardware must be of hospital grade where applicable, provide durability in high use occupancy, meet ABA requirements, and be aesthetically compatible with the design of the facility. A source of guidance on appropriate hardware selections and schedules is contained in Hardware for Healthcare Facilities, Door and Hardware Institute, latest edition. Provide a glass view panel in OR doors and other areas where staff may be transporting non-ambulatory patients.

## **6-12 SUSTAINABLE DESIGN.**

Reference Chapter 4 Sustainable Design Principles.

## **6-13 WAYFINDING PLAN.**

A wayfinding plan must be generated for all new Military Medical Facilities and types. The Design and Construction Agent must substantiate that all architectural and engineering systems, specifications, and contract documents support the elements and features proposed in the wayfinding plan. Signage, a tool associated with wayfinding, must be fully coordinated and consistent with the facility's wayfinding plan. Development of a wayfinding plan must begin at the start of a project's design and conclude with the project's final design submission.

For addition/alteration projects, coordinate the wayfinding plan with existing conditions. In the absence of a base or facility wayfinding master plan, evaluate and assess one's ability to navigate, via wayfinding cues, from the existing facility to the addition/alteration project. Consider adjacencies, circulation, building entrance locations, parking considerations, and overall building configuration as part of this evaluation.

**6-14            BEHAVIORAL HEALTH**

See Appendix C Design Submittals and Documentation and Appendix A Behavior Health Design for other specific requirements.

CANCELLED



## CHAPTER 7 STRUCTURAL

### 7-1 GENERAL.

This chapter provides criteria for the selection, analysis, and design of structural system(s) and materials to be used for Military Medical Facilities. Additional criteria relating to seismic design is provided in Chapter 8 Seismic.

### 7-2 DESIGN CRITERIA.

Structural design for Military Medical Facilities must be in accordance with UFC 3-301-01. The Risk Category of buildings and other structures must be based on the nature of occupancy in accordance with Table 2-2 of UFC 3-301-01 for the purpose of applying wind, snow, earthquake, or ice loadings. Refer to Chapter 8 Seismic for additional guidance related to the determination of Risk Category.

### 7-3 DESIGN LOADINGS.

Unless otherwise indicated herein, the minimum design loadings for Military Medical Facilities must be in accordance with UFC 3-301-01.

#### 7-3.1 Floor Live Loads.

Floor live loads must be in accordance with UFC 3-301-01, and as amended by Appendix B Architectural and Engineering Design Requirements.

#### 7-3.2 Seismic Loads.

Requirements for seismic design are contained in Chapter 8 Seismic.

### 7-4 ADDITIONAL DESIGN CONSIDERATIONS.

Several aspects of structural design typically associated with Military Medical Facilities are addressed here. It is essential that structural design considerations enter into the earliest stages of concept planning and design, to ensure compatibility with medical function and architectural and equipment features.

#### 7-4.1 Vibration.

Structural vibration requires special consideration. Designs must limit vibration in floor framing systems and must ensure adequate isolation and damping of vibrations produced by: HVAC equipment, emergency generators, elevator equipment, human activity and other machinery. Provide a vibration design in accordance with the following standards.

- Structural steel structures - AISC Design Guide 11: Floor Vibrations Due to Human Activity.
- Reinforced concrete structures – CRSI Design Guide for Vibrations of Reinforced Concrete Floor Systems.

- Steel Joist Institute Technical Digest 5, Vibration Analysis of Steel Joist-Concrete Floor Systems.
- UFC 3-450-01.

Limit hospital floor vibration to 0.5%g or less, except in the case of the following stricter requirements wherein the maximum acceptable floor velocity is listed in micro inches per second. These values must be superseded by any explicit manufacturer requirements:

- Hospital patient rooms: 6000 mips
- Standard operating rooms, surgery suites, bench microscopes up to 100X, and laboratory robots: 4000 mips
- Bench microscopes up to 400X: 2000 mips
- Microsurgery, eye surgery, neurosurgery, and bench microscopes greater than 400X: 1000 mips
- Magnetic resonance imagers: 500 mips

In addition, limit floor vibration according to manufacturer requirements for all other vibration sensitive equipment. The above noted floor vibration limitation must apply to the floor above where said equipment is attached to the ceiling structure.

## CHAPTER 8 SEISMIC

### 8-1 GENERAL.

This chapter provides seismic design criteria for permanent Military Medical Facilities. Seismic design requirements must be based upon UFC 1-200-01 and UFC 3-310-04.

### 8-2 HEALTHCARE AND DESIGN REQUIREMENTS.

The desired seismic level of performance for a particular Military Medical Facility is dependent on the nature of the occupancy and whether the structure is required for post-earthquake recovery. Assign a Risk Category, as defined in UFC 3-301-01, based on the facility function and the desired seismic performance level.

If required by the DD Form 1391, certain Military Medical Facilities may require only key areas to be operational after the Design Earthquake. Areas that are not required to remain operational may be assigned a lower Risk Category only if both the structural and non-structural systems are isolated from areas that are required to remain operational. Systems that are required to be operational following the Design Earthquake are identified as Designated Seismic Systems in accordance with ASCE 7.

### 8-3 POST-EARTHQUAKE EMERGENCY STATUS.

During the planning period, an evaluation of potable and fire protection water, fuel, sanitary sewer, and power, is required for all Risk Category IV facilities in Seismic Design Categories C and D to support continued operations 72 hours after a seismic event. Onsite storage of these lifeline utilities may be required when established by the project DD Form 1391.

### 8-4 CONCEPT DESIGN DEVELOPMENT.

Develop project specific seismic design concepts. Coordinate the type of structural system to be used in the early concept development of the functional layout, in accordance with UFC 3-310-04. Specific project criteria include mechanical, electrical, medical gases, and communication systems design criteria.

### 8-5 DESIGN OF NON-STRUCTURAL SYSTEMS.

Design all non-structural systems in accordance with UFC 3-310-04. Non-structural building systems and utility services, including selected medical systems that are required to be functional after the Design Earthquake are classified as Designated Seismic Systems. Mechanical and Electrical equipment in Designated Seismic Systems require Special Seismic Component Certification to ensure that they do not change state or fail. See UFC 3-310-04, Appendix C-1. Develop a complete list of Designated Seismic Systems for approval and identify in the Construction Documents.

### **8-5.1 Medical Systems and Equipment of Designated Seismic Systems**

Obtain the list of Fixed and Integral Medical Equipment from the Project Room Contents. For Logistical Category A, and B equipment, design seismic anchorage and/or bracing elements per ASCE 7 as amended by UFC 3-310-04. Specify anticipated loads and define anchorage and bracing requirements for Logistical Category C equipment, so this information can be incorporated into Category C equipment procurement contract. Provide a table in the construction documents that defines requirements for all Logistical Categories. Identify and specify Special Seismic Component Certification requirements for all equipment Categories.

### **8-5.2 Medical Systems and Equipment for Non-Designated Seismic Systems**

Obtain the list of Fixed and Integral Equipment and Furniture from the Project Room Contents. Identify elements where falling will pose a life safety hazard. For such elements in Logistical Categories A, and B, design seismic anchorage and/or bracing elements per ASCE 7 as amended by UFC 3-310-04. Specify anticipated loads and define anchorage and bracing requirements for Logistical Category C equipment, so this information can be incorporated into Category C equipment procurement contract. Provide a table in the construction documents that defines requirements for all Logistical Categories.

### **8-5.3 Hazardous Materials.**

#### **8-5.3.1 Special Storage Provisions.**

Provide special storage equipment or accessories that are convenient for normal daily use and functional after earthquakes. Examples of such equipment are lower profile shelves with face bars to secure shelves to the wall or floor and restrain their contents, specially designed racks for restraining reserve oxygen (O) and nitrous oxide (NO) tanks, and special bins for storing anesthetic gas containers.

#### **8-5.3.2 Fuel Gas Piping.**

Brace piping and provide shut-off valves. Use malleable fittings and valves, and provide swing joints where necessary.

### **8-5.4 Electrical Systems.**

#### **8-5.4.1 Vibration Isolation.**

Where vibration isolation is not required, bolt generators directly to an appropriate foundation. Where vibration isolation is necessary, provide restraining clips at vibration isolators to prevent failure of the isolation mountings in earthquake vibration conditions.

#### **8-5.4.2 Generators.**

Where practicable, use generators with integral radiator cooling systems. Where auxiliary cooling systems are necessary, install cooling towers or remote radiators at grade level. Brace cooling towers or radiators and provide special bracing for piping.

#### **8-5.5 Medical Systems and Equipment.**

##### **8-5.5.1 General Requirements**

###### **8-5.5.1.1 Stationary equipment**

Secure stationary equipment or shelving to a partition or floor. Shelving or equipment with doors that does not require continuous access must have automatic positive latching devices.

Blood bank, drug storage, critical refrigerators, freestanding incubators, and centrifuges should be secured.

###### **8-5.5.1.2 Fragile equipment**

Secure sequential multiple blood analyzers and other fragile laboratory equipment. Anchor related shelving and provide lips and face bars as necessary.

###### **8-5.5.1.3 Wheeled equipment**

Wheeled equipment must have wheel locks and must be assigned a specific location when not in use. Wheeled equipment must have programmed closets or alcoves whenever possible to limit rolling. Portable equipment must be stored in recessed cabinets secured to partitions, whenever possible.

##### **8-5.5.2 Supply Storage.**

Supply cabinets must have either plastic or tempered glass sliding doors, and the doors must slide closed automatically. Open shelving should have a shelf rim to preclude supplies from being shaken from their storage position.

##### **8-5.5.3 Medical Gas Bottles.**

Metal boxes attached to the floor and equipped with double chains must be provided for medical gas bottles. Wheeled carts carrying oxygen or other medical gases must be equipped with wheel locks and chains for fastening to walls.

#### **8-6 EVALUATION OF EXISTING FACILITIES.**

For existing Military Medical Facilities, the Design and Construction Agent and the Using Agency must verify the performance objective or Risk Category and the Designated Seismic Systems required for Military Medical Facilities, as established in the planning documents. The performance objectives are defined in UFC 3-310-04, and

must consider operational mission, disaster preparedness, and medical post-earthquake needs.

**8-6.1 Seismic Hazards Evaluation Considerations.**

Seismic Structural Evaluations. Seismic structural evaluations and retrofit of existing buildings must be conducted in accordance with UFC 3-310-04. For proposed facility alteration projects, seismic structural evaluations must be conducted during the project requirements planning phase. Reference Chapter 2 Predesign.

CANCELLED

## CHAPTER 9 PLUMBING AND MEDICAL GASES

### 9-1 GENERAL.

This chapter provides design guidance for plumbing and medical gas systems. The primary purpose of these systems is to provide safe and reliable support to the medical functional mission. In addition, appropriate design consideration must be given to ensure system maintainability, economy and energy efficiency, and adaptability to future facility modification or expansion. For plumbing-related issues associated with fire protection systems, reference Chapter 14 Fire Protection and Life Safety.

#### 9-1.1 Supplemental Criteria and Standards.

This chapter may be supplemented with individual Using Agency criteria, including Installation-specific requirements, as established by the Design and Construction Agent. Minimum design requirements must be as provided by the International Plumbing Code (IPC) in accordance with UFC 3-420-01, the NFPA Standards, and the other documents noted in this chapter.

#### 9-1.2 Plumbing Systems.

Plumbing systems include domestic cold and hot water; sanitary, storm, and industrial (acid) waste drainage; water treatment, e.g., softening, deionization, reverse osmosis; fuel gas; and landscape irrigation. Plumbing systems must be designed to be safe, reliable, and maintainable. Selection of materials, equipment, and installation techniques must consider LCC effectiveness and maintainability in addition to medical functional requirements. Designers must provide for appropriate system isolation and balance with necessary equipment and design practices to avoid cross-connections and backflow.

#### 9-1.3 Medical Gas and Vacuum Systems.

Medical gas and vacuum systems include compressed air (medical, dental, instrument, medical laboratory, dental laboratory, process), vacuum (medical, dental surgical, oral evacuation [OE], waste anesthesia gas disposal [WAGD]), exhaust (laboratory dental), positive pressure gases (nitrogen [N], oxygen [O], nitrous oxide [NO], carbon dioxide [CO<sub>2</sub>]), and the associated equipment, e.g., piping, filters, regulators, alarms, manifolds, and tanks.

#### 9-1.4 Seismic Requirements.

Seismic design criteria for bracing and utility systems, e.g., storage, redundancy, are provided in Chapter 8 Seismic.

#### 9-1.5 Corrosion Protection.

All piping that must be installed in an environment that supports galvanic reaction must be protected from corrosion in accordance with Using Agency criteria and the standards and recommended practices of the National Association of Corrosion Engineers.

## **9-1.6 NFPA 99 Risk Assessment**

A Risk Assessment must be performed in accordance with NFPA 99 to establish the System Categories for all medical gas and plumbing systems. See Appendix C for the timing and responsibilities of the Risk Assessment.

## **9-1.7 Piping Coordination**

9-1.7.1 All piping systems must be installed in a manner that promotes cleanliness, protection of room contents and addresses infection control concerns.

9-1.7.2 Piping must be concealed under floor, within walls, and/or above ceilings, except in dedicated mechanical spaces.

9-1.7.3 Piping must not be routed over communications, electrical and server rooms unless dedicated to serving the room as indicated in Chapter 11 Electrical and 12 Communications. Where feasible, avoid routing piping above other sensitive areas such as: operating rooms, delivery rooms, nurseries, food preparation areas, food serving areas, food storage areas, sterile processing (clean side). Where routing over sensitive areas cannot be avoided, provide all wet and drainage piping with special protection provisions (e.g. double wall containment piping or drip pans with leak detection) to protect the space below from leakage and/or condensation.

## **9-2 POTABLE WATER SUPPLY SYSTEM.**

### **9-2.1 Quality.**

All potable water supplies must have an established potability monitoring program to be acceptable for use by an MTF. When an MTF project includes a non-potable water service, e.g., “gray water,” for systems, such as irrigation, heating, or cooling, the design must provide for requirements for signage, pipe labeling, and other means as needed to clearly identify the system (including outlets) as unsafe for human consumption.

### **9-2.2 Continuity of Service.**

For Hospitals and Ambulatory Healthcare Centers with operating rooms, provide a minimum of two water services, fed from either separate mains and sources or separate connections to a multi-sourced network, each designed for full demand (serving potable, process, and fire protection systems). These services must enter the building at separate locations from a piped loop around the facility with isolation valves. The purpose of this provision is to provide an uninterrupted supply of potable water or permit swift service restoration in the event of a water main break. If two separate water sources are not reasonably available, the Design and Construction Agent may seek authorization from DHA/FE to utilize onsite storage in lieu of a second water service.

### **9-2.3 Backflow Prevention.**

Designers must coordinate backflow prevention requirements, including requirements for maintenance accessibility and periodic testing, with the Design and Construction



Agent. In order to facilitate mandatory testing and maintenance without disruption to the facility water supply, provide a minimum of two backflow preventers in parallel on the service connection to any MTF with 24/7 operation.

**9-2.3.1 Devices and Methods.**

All potable water discharge points, such as a faucet discharging into a reservoir sink or tub, must be provided with an adequate air gap in accordance with UFC 3-420-01. Fixtures or equipment where the discharge point is positioned below the reservoir rim must be fitted with a vacuum breaker. Examples of concern include the devices listed here:

- a. Bedpan washers, or similar fixtures including a flushometer valve;
- b. Flexible hoses or shower heads of length sufficient to reach below fixture rim, typically found in procedure rooms, hydrotherapy bath equipment, laboratories, and food service areas, e.g., washers, steam tables;
- c. Laboratory or other serrated-nozzle fixtures designed to accept flexible tubing;
- d. Water delivery outlets serving therapeutic, surgical, or autopsy or mortuary procedures; and
- e. Hose bibs and wall hydrants.

For the protection of make-up supplies to low-hazard equipment, e.g., autoclaves and fire protection sprinkler systems, double-check backflow preventers may suffice. For the protection of sources supplying the building with potable water, and for high hazard equipment and processes, reduced-pressure backflow preventers are required. Designers must include provisions for drainage of the discharge from these devices; refer to Table 9-1 and Table 9-2.

**Table 9-1 Potential Backflow Preventer Discharge Rates**

<b>Assembly Pipe</b>	<b>Discharge GPM</b>	<b>Discharge GPM</b>
<b><u>Size in inches</u></b>	<b><u>at 60 PSI</u></b>	<b><u>at 150 PSI</u></b>
3/4–1 1/4	75	140
1 1/2–2	170	280
2 1/2–3	250	400
4–6	500	850
8–10	525	890
GPM = gallons per minute		
PSI = pounds per square inch		

**Table 9-2 Floor Drain Flow Rates**

<b>Drain Size</b>	<b>Flow Rate*</b>
<b>Inches</b>	<b>GPM</b>
4	88
6	264
8	575
10	1050
12	1700
* Flow rates for a floor drain with slotted cover and 1/8 inch drain pipe slope.	

#### **9-2.4 Water Treatment.**

A water chemistry analysis reporting, at a minimum, calcium and magnesium concentrations and the water hardness must be used as the basis for determining the potable water treatment design scope. Water treatment equipment packages requiring regeneration of media or components must include multiple units as required to permit routine maintenance. Water treatment technologies for the control of waterborne pathogens are discussed at 9-2.5 Waterborne Pathogens.

##### **9-2.4.1 Scale Control.**

Provide water softening when the water supply to the facility has a hardness of 10 grains per gallon (gpg) or more. The softening system should be designed to deliver water with hardness between 3 gpg and 5 gpg; the designer must assess whether any specialized equipment used in the MTF may require more stringent requirements. Dental facilities' water hardness must not exceed 5 gpg. The water softening system must include a proportional blending valve. Design must include provisions for softener regeneration discharge, which may require a floor sink or receptor.

##### **9-2.4.2 High Purity Water Systems.**

Water purification is the process by which contaminants or impurities, which undesirably affect the performance of specific equipment or the outcome of medical and laboratory tests, are removed from the water. Water purification systems include reverse osmosis, deionization, ultra-filtration, and ultraviolet (UV) sterilization. Type I and Type III reagent grade water, as specified in ASTM D 1193, are used in various applications such as for medicine preparation processes in pharmacies, in distillation units, for designated laboratory outlets, and in selected equipment for renal dialysis, glassware washing, central sterile supply, and other medical and laboratory functions. Their use must be coordinated with the Using Agency and the Design and Construction Agent. The designer must consider local and central treatment options and treatment system combinations best meeting the Using Agency's needs and overall LCC. Refer to

Chapter 10 Heating, Ventilation, and Air Conditioning for make-up water treatment design guidance for steam systems.

### **9-2.5 Waterborne Pathogens.**

Although this document primarily focuses on *Legionella*, other waterborne pathogens are of equal concern. *Pseudomonas* is the second most common nosocomial infection (infection in hospitalized patients). The relative danger that *Legionella* and other waterborne pathogens pose in any given MTF is a function of (a) “system” factors that promote or discourage colonization, (b) the relative vulnerability of the patient population, and (c) climate and groundwater temperature. Procedures that increase aspiration increase the risk of infection from waterborne pathogens, as does the presence of aerosol-generating sources, such as showers and whirlpool baths. More seriously ill patients, particularly those who are immunocompromised by medical condition or treatment, are more vulnerable to infection than the general population. In addition to potential contamination danger from hot water systems, cold water systems pose the risk of supporting pathogen colonization if the piping systems are subjected to heat sources. The temperature of cold water systems might inadvertently be elevated into ranges more conducive to pathogen colonization by ground temperatures, piping located in attics, ceiling spaces, equipment rooms, crawlspaces, other unconditioned spaces, or by being located adjacent to hot water or steam piping. All of these risk factors must be considered when designing the domestic water system.

#### **9-2.5.1 Scale, Sediment, and Biofilm.**

Scale, sediment, and biofilm are contaminants that support *Legionella* bacteria (and other waterborne pathogens) colonization. The extent to which these contaminants support colonization is a function of factors including potable water service quality (including the presence of living aquatic amoebae such as are found in biofilms), system operating temperatures, and pipe material. Standard control technologies for scale and sediment deposits normally minimize the contribution of these factors to pathogen colonization. Biofilms are resistant to some treatments.

#### **9-2.5.2 Connections to Existing Systems.**

For addition and alteration projects, designers and facility managers must be aware of the potential presence of established biofilms, sediments, and scale. Flushing and disinfection may be required per ASHRAE Guideline 12.

#### **9-2.5.3 System Design.**

The design of the building water system must address on management of water temperature, minimizing water age, reducing stagnation, maintaining a sufficient disinfectant residual and minimizing the use of materials that support colonization. These factors are critical to maintaining water quality and managing control of waterborne pathogens.

9-2.5.3.1 Treatment systems for waterborne pathogen control of the hot and cold water supplies must be provided for Hospitals and Ambulatory Healthcare Centers with

operating rooms. Examples of treatment systems are copper-silver ionization or chlorine dioxide injection, etc. The selection of a treatment system must be supported by an ASHRAE 188 risk analysis. Designs must also include continual monitoring and trending of water temperature, pH, pressure, chlorine residual and any other environmental sampling or monitoring required for the selected treatment system.

9-2.5.3.2 Potable water distribution within the building must be copper or stainless steel. Specify equipment, and fixture components intended for direct water contact to be of materials that inhibit bacteria colonization, such as copper. For inpatient MTFs, avoid materials that support colonization, such as natural rubbers and some plastics, whenever practicable.

9-2.5.3.3 Design hot and cold water distribution mains to maintain balanced flow throughout. Piping runs should be as short as practicable. Avoid creating piping “zones,” which experience infrequent use and, therefore, stagnation. As practicable, route mains close to fixtures to minimize the lengths of branch piping runs. Avoid stagnant piping sections, e.g., dead legs. Do not locate cold water piping near hot water piping or other heat sources. The developed length from the domestic hot water line (recirculated) must not exceed 6 feet for showers, emergency showers, and emergency eyewashes and must not exceed 10 feet for all other fixtures.

9-2.5.3.4 Locate pressure balancing and thermostatic mixing anti-scald valves as close as practicable to the fixture discharge. Do not exceed a 6 foot developed length from the valve to the fixture discharge.

9-2.5.3.5 To avoid stagnant storage conditions, consider semi-instantaneous and instantaneous hot water generators where feasible and when onsite storage is not required by other criteria.

9-2.5.3.6 Water storage of holding tanks, both cold and hot, must be designed to have continuous flow. Consider using horizontal tanks with baffles to limit stagnation. Storage tank capacity must be adequate for the application, but not oversized.

9-2.5.3.7 The treatment system for waterborne pathogen control must be registered by the manufacturer with the EPA as a biocide for drinking water. Comply with applicable federal, state and local government requirements. Start-up and activation of the treatment system must be integrated into the Commissioning Plan including documenting the baseline (pre-activation) and post-activation water quality; pre and post disinfection agent (e.g. copper ions, residual chlorine levels), etc. These tests must be performed by a laboratory in addition to any field testing required by the manufacturer. A plan for on-going distal flushing and monitoring must be established in accordance with the manufacturer's recommendations and implemented immediately upon system activation (even before building occupancy). The plan must initially be implemented by the construction contractor and then integrated into the facility's ongoing maintenance plans.

**9-2.6 Domestic Hot Water Systems.**

**9-2.6.1 Hot Water Demand.**

The demand load can be calculated using several different methods, examples of which are contained in the *ASHRAE Handbook: HVAC Applications* and the *American Society of Plumbing Engineers (ASPE) Data Book*. The preferred method for calculating hot water demand for an MTF is the Per Fixture method. This method provides a means to account for various uses within each facility, and permits the tabulation of the hot water load using a specified demand for each fixture.

Table 9-3 provides a list of representative fixtures taken from MIL-STD-1691 and their demands based on data provided in *ASHRAE Handbook: HVAC Applications* and the *ASPE Data Book*. For any fixture not shown, the designer must determine the demand rate based upon experience, standard practice, and available Using Agency input. The Per Fixture method is adequate for typical usage. Expanded usage for food service, non-standard fixtures, or abnormal usage patterns (extreme low- or high-demand peaks or erratic peak duration and occurrence) must be factored into the sizing calculations. For example, food service fixture demand factors need to be adjusted if disposable service ware is used. Concentrated patient treatment for sick call, or other instances of high-peak usage are other examples of fixture hot water demand adjustment.

**Table 9-3 Hot Water Demand per Fixture for MTFs**

<b>FIXTURE</b>	<b><u>GPH</u></b>	<b><u>HW SFU</u></b>
Sink, Clinic	4	3
Sink, Plaster	10	3
Sink, Service (General)	20	3
Lavatory, Public (General)	6	1½
Lavatory, Patient (Private)	2	1
Lavatory, Clinic	8	3
Basin, Mop Service	20	3
Shower, Staff or Patient Group	75	3
Shower, Patient (Private)	30	2
Shower, Hydrotherapeutic	400	11
Bathtub	20	3
Bath, Whirlpool, Arm	35	3
Bath, Whirlpool, Arm/Foot/Knee	15	3
Bath, Whirlpool, Leg	100	7
Bath, Body Hydrotherapy (Hubbard)	600	17
Bath, Sitz	30	3
GPH = gallons per hour SFU = supply fixture units		

9-2.6.1.1 Summing individual fixture demands provides the Possible Maximum Demand. A Demand Factor is applied to the Possible Maximum Demand to calculate the Probable Maximum Demand. The Probable Maximum Demand is the rate at which the heater must generate hot water, or the recovery rate.

9-2.6.1.2 The Demand Factor and Storage Capacity Factor are listed in the ASHRAE Handbook: HVAC Applications and the ASPE Data Book for given building types, which includes hospitals but not medical clinics, dental clinics, nor laboratories. A Demand Factor of 0.40 and Storage Capacity Factor of 1.00 must be used for clinics. Factors for MTFs with laboratory space greater than 10 percent of the total facility space must be coordinated with the Design and Construction Agent. The Probable Maximum Demand is factored by the Storage Capacity Factor to determine the Storage Tank Capacity. The Storage Tank Capacity is the capacity required to be available for use. Storage tanks are not considered to be 100 percent usable and thus, a Usable Storage Tank Factor must be applied to the Calculated Storage Tank Capacity, unless the water in the entire tank is recirculated. The percent capacity considered usable for most tanks is 70, thereby resulting in a 1.43 Usable Storage Tank Factor. The Usable Storage Tank Factor for systems utilizing instantaneous generators or multiple tank arrangements must be coordinated with the Design and Construction Agent.

#### **9-2.6.2 Hot Water Design Temperature.**

Domestic hot water must be generated and stored at a minimum 140 degrees F. It must be tempered with a thermostatic mixing valve at the hot water generator discharge to permit distribution at a temperature range between 122 and 126 degrees F. The maximum hot water temperature distribution design set point must be 122 degrees F. However, provide the capability to increase system temperature to 126 degrees F to permit an MTF the option to increase the temperature if so recommended by the Infection Control and Prevention Officer. It is extremely important to note that at this temperature, the exposure time for a first-degree burn is approximately 45 seconds. This is considered an adequate period for a fully aware adult to remove the exposed body area from the stream of a sink or lavatory, thereby maintaining a relatively safe condition at these fixtures without the requirement for an anti-scald valve. Infants, persons desensitized by medical condition or treatment, or those with severely limited motor capabilities, may be endangered by water at this temperature. Maximum hot water temperatures for other applications must not exceed what is noted here:

#### **9-2.6.2.1 Supply and Utility Areas.**

Central sterile supply, soiled utility rooms equipped with bedpan washers, cart wash areas, and special pathological wash areas must be provided with 140 degrees F hot water.

#### **9-2.6.2.2 Kitchen Areas.**

The temperature normally required in dietary areas is the same as that distributed to standard hand washing and bathing plumbing fixtures. Dishwashing (automatic equipment) and pot washing normally require 180 degrees F. Booster heaters must be provided to obtain this temperature.

#### **9-2.6.2.3 All Other Areas.**

All other domestic hot water applications must be provided with a hot water temperature the same as is distributed to standard hand washing and bathing fixtures.

#### **9-2.6.3 Hot Water Recirculation.**

Provide hot water recirculation systems for all facilities designed to limit system temperature drop by 6 degrees F or less, and include provisions for isolating and balancing the system. Heat tape systems must not be used in lieu of hot water recirculation systems.

#### **9-2.7 Plumbing Fixtures and Other Equipment.**

Plumbing fixtures should conform generally to American Society of Mechanical Engineers International (ASME) Standards Series A112 or International Association of Plumbing and Mechanical Officials (IAPMO) Standards Series Z124. For uniformity, all fixtures must be identified by the Joint Schedule Number (JSN) provided in MIL-STD-1691. Quantities of fixtures must be in accordance with the approved PFD.

##### **9-2.7.1 Accessibility Fixtures.**

Provide accessible fixtures in accordance with Chapter 13 Accessibility Provisions for the Disabled.

##### **9-2.7.2 Drinking Water Coolers.**

Locate public drinking water coolers convenient to each public waiting room and elsewhere as required by the IPC and as directed by the Using Agency. The standard rating and performance must conform to Air Conditioning and Refrigeration Institute (ARI) Standard 1010.

##### **9-2.7.3 Emergency Shower and Eye Wash Fixtures.**

Emergency shower and eye wash fixtures must be designed in accordance with the American National Standards Institute (ANSI) Standard Z358.1.

##### **9-2.7.4 Water Usage Conservation.**

Water usage conservation design must comply with EO 13514. Specify low-flow fixtures for all projects.

### **9-2.7.5 Wall Hydrants**

Provide wall hydrants where required by UFC 3-420-01 and also within 20 feet of any loading dock, emergency room ambulance drop-off, and ambulance shelter.

### **9-2.8 Coordination with Medical and Dental Equipment**

Medical and Dental equipment can have special water quality and pressure requirements. Plumbing designers must carefully analyze the building water supply condition before starting a project design. When a facility building water supply cannot meet equipment manufacturer's requirements, local (or centralized) water treatment systems and/or water pressure boosters must be provided in appropriate mechanical spaces.

## **9-3 SANITARY DRAINAGE SYSTEM.**

The MTF sanitary waste system must be connected to an approved existing sewer system, either Government or private as appropriate. If an existing sewage disposal system is not available, an approved alternative system must be provided. For example, a holding tank may be acceptable for remote locations, for temporary service while awaiting the installation or retrofit of an approved sewage disposal system, or a backup such as for hardened or essential facilities. Any alternative to an approved central sanitary system must be coordinated with the Installation's local approving authority. When connected to a local public system, code requirements in excess of the IPC imposed by the local regulatory agencies must be considered in the design. The system must be designed to avoid excessive back pressure and aspiration effects. Provide adequate cleanouts to permit access to all sections of the waste drainage system. Locate the cleanouts to avoid or minimize disruption of medical functions. If a facility sanitary waste requires lifting or pumping, comply with UFC 3-240-01. Connect this equipment to the alternative power source if one exists or is included in the project scope.

### **9-3.1 Protection of Special Fixtures and Equipment.**

Fixtures and equipment used for sterilization, and food preparation, processing, or storage, must be protected from contamination by backflow of waste. An indirect waste line, such as an air break or physical disconnection (open drain) at the associated waste outlet, must be incorporated into the system design. These provisions also apply to equipment that cannot be easily cleaned. Included are sterilizers, glass washers, refrigerators, kitchen equipment, dental laboratory equipment, e.g., boil-out assembly tanks, and vacuum system separator tanks.

### **9-3.2 Special Drainage Equipment.**

Interceptors must be provided when precious materials or heavy metals, such as silver and barium, or sediment is in the waste drainage from spaces such as cast rooms, prosthodontics laboratories, barium procedure areas, and spaces employing blood analyzers. Interceptors for barium waste must be aluminum. Flush rim floor drains must be provided in Autopsy. Food waste disposers must be provided in kitchens on



dishwashers, pot and pan sinks, and other sinks as designated. Grease traps must be provided with grease-producing kitchen equipment including prewash sinks, pot washers or sinks, and floor drains serving kettles. Separators must be provided in areas where petroleum products are subject to dripping or spills, such as ambulance garages and mechanical equipment rooms.

### **9-3.3 Special Purpose Waste Lines.**

Separate waste lines must be provided for acid waste and radioactive waste from laboratories and nuclear medicine treatment rooms when justified by the quantities, concentration, or both, of reagent expected to be introduced. Acid-resistant waste piping must be utilized for such applications and, if required, must pass through a neutralizing or dilution tank before combining with building waste. If more than test tube quantities of acid or strong base solutions are to be discharged into the waste system, neutralization is required. There are various radioactive materials to be found in an MTF. The particular radioactive waste for a given facility must be identified. The appropriate prescribed manner of disposal in accordance with Federal and local safety standards must be incorporated into the design.

### **9-3.4 General-Purpose Floor Drains.**

General-purpose floor drains must be considered for rooms in which water-using plumbing fixtures or equipment are located. These include physical therapy (PT) rooms that are equipped with hydrotherapy equipment, central sterile areas for sterilizers and sanitizing washers, food service areas, wash-down and housekeeping spaces, and mechanical equipment rooms that contain water-using equipment. Floor drains must be required for restrooms designed for more than single-use occupancy. Floor drains are normally not required at emergency shower locations. Floor drains, where provided, must follow the criteria in UFC 3-420-01.

### **9-3.5 Trap Priming.**

Where a trap seal is subject to loss by evaporation, a trap seal primer valve must be installed per IPC, or a deep seal trap must be provided in accordance with UFC 3-420-01. When utilized, automatic primers must incorporate a backflow prevention feature. Other means of trap prime maintenance are not permitted.

### **9-3.6 Retrofit or Alteration Considerations.**

The replacement of older existing fixtures with lower-flow fixtures may alter system performance. Smaller diameter pipe or increased slope must be considered.

### **9-3.7 Elevator Pit Sumps.**

Elevator pits must be provided with a sump, which must be either pumped or drained by gravity. Pumped designs must include integral oil sensors and must deliver fluids to an indirect connection to the sanitary or storm drainage systems, such as a floor drain. The sump discharge line must include a check valve to prevent backflow of fluid into the sump. If permitted by the local jurisdiction, a direct connection to the storm drainage

system may be considered. Designers should also assess whether the Using Agency requires an oil interceptor. No other drains or sump discharges must be connected to the elevator pit drain or sump. This equipment must be connected to the alternative power source if one exists or is included in the project scope. Refer to Chapter 16 Transportation and Logistics, for additional requirements.

**9-3.8 Mercury Control.**

Facilities containing operations that generate mercury wastes in the free or leachable, (e.g. dental filling amalgams) must be provided with ISO 11143 certified amalgam separators and any additional Federal, state or local requirements. See also paragraph 9-5.19.1.

**9-3.9 Dialysis Waste Box**

Provide dialysis waste box drains with automatic trap primers and/or automatic disinfection systems.

**9-4 FUEL GAS SERVICE.**

Applications for fuel gas utilization in MTFs include a fuel source for space heating, domestic hot water generation, cooking, generation of steam for humidification and sterilization, and as a point-of-use heat or flame source to support medical and laboratory functions. Fuel gas system design, including liquefied petroleum gas systems, must be in accordance with NFPA 54, 58, and 59A, as applicable.

**9-5 MEDICAL GAS SYSTEMS.**

Medical gas systems for all applications covered by this UFC must comply with NFPA 99. Unless otherwise noted, the term “medical gas systems” in this UFC refers to all medical gas, dental gas and vacuum systems. Refer to Table 9-4 for general medical gas systems information.

**Table 9-4 Medical Gas Systems<sup>a</sup>**

Reference NFPA 99		
	Appendix B Notation	Nominal Description
Compressed Air		
Medical Compressed Air	MA	345–380 kPa ( 50–55 psig)
Dental Compressed Air	DA	620–655 kPa ( 90–95 psig)
Laboratory Air - Dental	LA	210–245 kPa ( 30–35 psig)
Laboratory Air - Medical	LA	345–380 kPa ( 50–55 psig)

	Appendix B Notation	Nominal Description
Instrument Compressed Air	IA	1100–1275 kPa (160–185 psig)
Process Air	PA	830–865 kPa (120–125 psig)
Vacuum		
Medical Surgical Vacuum	MV	51–65 kPa (15–19 in-Hg)
Dental Surgical Vacuum	DSV	51–65 kPa (15–19 in-Hg)
Oral Evacuation	OE	21–27 kPa ( 6–8 in-Hg)
High Volume Lab Dust Evacuation	LDE	10 kPa ( 3 in-Hg)
Waste Anesthesia Gas Disposal	WAGD	21 kPa ( 6 in-Hg) <sup>b c</sup>
Gases		
Oxygen	O	345–380 kPa ( 50–55 psig)
Carbon Dioxide	CO2	345–380 kPa ( 50–55 psig)
Nitrous Oxide	NO	345–380 kPa ( 50–55 psig)
Nitrogen	N	1100–1275 kPa (160–185 psig)
<p><b>Equation 9-1.</b> Other gas systems included in this chapter but not in Appendix B Architectural and Engineering Design Requirements: Gas (natural or propane) – flame or heat source.</p>		
<p><b>Equation 9-2.</b> This is a minimum value; vacuum controlled by healthcare provider administering the anesthesia gas.</p>		
<p><b>Equation 9-3.</b> For veterinary care, design pressure must be coordinated with the anesthetizing equipment.</p>		
psig – pound-force per square inch gauge		

### **9-5.1 Application of NFPA 99 to Dental Systems**

Dental gas and vacuum systems must comply with NFPA 99 and this UFC. Allowances/exceptions in NFPA 99-2018 Chapter 15 which reduce/relax NFPA 99 Chapter 5 system requirements are NOT permissible; as such do not incorporate any of the exempted features into designs for dental systems. All requirements for piping, piping installation, warning systems, testing and verification must follow NFPA 99 Chapter 5 for the system category determined in NFPA 99 Chapter 15. For example, if a Dental Air system is determined by NFPA 99 Chapter 15 to be Category 2, the system must meet all Category 2 requirements in NFPA 99 Chapter 5 as well as the prescriptive requirements in this UFC.

### **9-5.2 Application of NFPA 99 to Veterinary Care**

Medical gas systems for veterinary care must comply with NFPA 99 even though NFPA 99 indicates an exclusion for veterinary care. The required Risk Assessment process must be carefully implemented with the unique considerations of the veterinary patients and caregivers to arrive at appropriate System Categories.

### **9-5.3 Systems for Medical Clinics.**

Centrally-piped medical gas/air/vacuum systems are not normally required or authorized for outpatient medical treatment clinics, with the exception of Ambulatory Healthcare Centers. If attached to a facility having central systems, designers must consider extending service lines to the clinic if LCC effective.

### **9-5.4 Systems for Dental Clinics.**

Centrally-piped systems must normally be provided for dental compressed air (DA), OE, dental surgical vacuum (DSV), high volume laboratory dust evacuation (LDE), and dental laboratory air (LA). A separate system for WAGD must be required unless the Using Agency designates the DSV system for that purpose. Fuel gas (natural or propane) must be provided as required to support prosthodontic and orthodontic laboratories and DTRs. For freestanding clinics with fewer than five chairs, selection of a central system for gases as opposed to point-of-use systems must be based upon LCC considerations.

### **9-5.5 Criteria for Medical Gas Design in the Federal Republic of Germany (FRG).**

Considerations of safety and practical constructability require that medical gas system designs for facilities in the FRG be in accordance with European Norm (EN) 737 Standards 1–4 (replaced by International Organization for Standardization [ISO] 7396 and 9170), and other EN and Deutsche Industrie Normen (DIN) standards cited therein, supplemented with the requirements of this document and NFPA 99 to include:

9-5.5.1 Pipe marking labels must be color-coded per EN standards, with German language name of the gas or vacuum. In addition, a label carrying the English language name of the gas must be affixed at the same location.

9-5.5.2 Gas outlet and vacuum inlets must have connections geometrically specific to a single gas or vacuum, non-interchangeable among other gases. Outlet and inlet labels must be of a neutral color meeting EN requirements, consisting of a black or white background with white or black lettering, respectively, identifying the gas' chemical symbol. Additionally, colors on the medical gas symbols must be in accordance with NFPA 99 to assist in quickly identifying the appropriate outlet.

9-5.5.3 Piping and source producer must be sized to meet the maximum demand identified by this document or by NFPA 99, at distribution pressures identified herein.

9-5.5.4 Flux must not be used in the brazing process.

9-5.5.5 Continuous piping purge with oil-free nitrogen gas must be required during brazing.

9-5.5.6 A nitrogen purge blow down of piping must be required before connection of the gas or vacuum outlet/inlet in accordance with NFPA 99.

9-5.5.7 The EN 737 "Test for Particulate Testing of the Pipeline" (replaced by ISO 7396 and 9170) must be modified to meet the more rigid testing requirements of the Piping Particulate Test of NFPA 99.

9-5.5.8 Two master alarm panels must be provided for each facility. Additional alarm features required by NFPA 99, but not by ISO 7396 and 9170, must be provided for master, local area, and source equipment alarms panels.

9-5.5.9 Medical gas zone valves must be in accordance with ISO 7396 and 9170, of the ball type. Pressure gauges must be provided on the pipelines at the valve box locations. The medical vacuum line must include a shut-off valve similar to the other gas services.

9-5.5.10 Two vacuum producers, each sized for 100 percent of demand, must be provided for the WAGD system.

## **9-5.6 Medical Gas System Installation and Testing.**

Medical gas systems must be installed and tested in accordance with NFPA 99.

## **9-5.7 System Control Valves.**

All medical gas centrally-piped systems must be provided with shut-off valves and zone valve box assemblies in accordance with NFPA 99. Additional shut-off valves must be included as designated by the Design and Construction Agent to provide system section isolation for maintenance or alterations.

## **9-5.8 Alarm Systems.**

Medical gas alarm systems must be provided for all centrally-piped systems in accordance with NFPA 99.

## **9-5.9 Gas System Sources (Storage).**

Gas system sources or storage provisions must be designed in accordance with NFPA 99. Flammable and nonflammable storage containers must be stored in separate enclosures. Bulk oxygen storage design must be in accordance with NFPA 55.

### **9-5.9.1 Point-of-Use Sources.**

Point-of-use cylinders are defined as B, D, or E sizes. The designer must coordinate with the Using Agency the provisions for point-of-use cylinder storage when use is planned. Storage in the storage room for central system cylinder banks is permissible. The point-of-use cylinder volume must be included in the total when determining the storage room ventilation requirements. Design must incorporate Compressed Gas Association (CGA) requirements of Pamphlet P-2.

### **9-5.9.2 Alternative Compressed Air Sources.**

Alternative compressed air sources, such as pneumatic control air or shop air compressors, must not be used as a source for medical compressed air (MA), DA, LA, instrument air (IA), or process air (PA).

### **9-5.9.3 Oxygen Concentrators**

Oxygen Concentrators may only be considered for utilization in unique circumstances where a reliable source for oxygen delivery is not available such as in forward deployed isolated locations. A written request documenting the requirement for this type of system must be provided and coordinated with the Using Agency, DHA/FE and the Design Construction Agent. When authorized these systems must comply with NFPA 99.

## **9-5.10 Color Coding and Labeling.**

Labeling and color identification of piping must be in accordance with NFPA 99 and the CGA Pamphlet C-9. System components must also be labeled for identification to prevent tampering and inadvertent closing. In particular, shut-off valves and pressure gauges must be labeled in accordance with NFPA 99.

## **9-5.11 Medical Gas Systems Outlets.**

Appendix B Architectural and Engineering Design Requirements contains guidance for allocation and location of medical services and outlets in the various spaces within an MTF. Refer to the MHS Templates for typical locations of medical equipment that may require medical gas. The designer must coordinate the gas types and outlet quantities with the Using Agency. Additional outlets and gas types may be provided when justified by the Using Agency to DHA/FE. All outlets must comply with the latest edition of NFPA 99 and the requirements of CGA Pamphlet V-5. There are Diameter Index Safety System (DISS) and quick connect-type outlets, with three primary configurations of the quick connect outlet (geometric configuration, pin index, latching type). Therefore, the

designer must also coordinate the outlet type configuration with the Using Agency so users must not have to use outlet adapters for existing medical equipment.

The use of a central medical gas system to serve an outlet that indirectly supports the medical function, such as in a laboratory, may be justified. If so, the branch piping and outlets must be in accordance with NFPA 99. Non-medical uses are not permissible except for unique circumstances with documented waiver requests, coordinated with the Using Agency and Design and Construction Agent, reviewed individually.

#### **9-5.12 Power Source for Medical Gas Systems.**

Medical gas system equipment must be served by an EES where determined through an NFPA 99 Risk Assessment or where otherwise required within NFPA 99 or this UFC.

#### **9-5.13 Medical Compressed Air (MA).**

The MA system must be an independent centrally-piped system consisting of two or more medical air compressors and a central receiver, all conforming to the requirements of NFPA 99. It must be used only for medical functions requiring breathable air to support respiration or for air-driven instruments that discharge into the pharynx. The MA system must not be used to satisfy any other compressed air requirements. The system design must include automatic operation of the compressors, including alternating lead and lag status.

##### **9-5.13.1 Air Quality Standards.**

Medical air compressors must be specifically designed and manufactured for this purpose. MA quality must be as defined in NFPA 99. Intake air must be direct from outdoors or another source of equal or better quality located in accordance with NFPA 99. Designers are responsible to size and show routing of medical air intake piping.

##### **9-5.13.2 General Requirements.**

MA must be provided by two or more compressors with provisions for automatic, alternating, and simultaneous operation. The compressors must be sized such that if any one compressor fails, the remaining compressor(s) must provide 100 percent of maximum system demand. Provide an alarm to indicate compressor failure that annunciates at the master medical gas alarm panel. All system components downstream of the compressors must be sized for 100 percent standard system demand and be duplexed. The receiver must be sized per manufacturer recommendation and must have an automatic drain feature.

##### **9-5.13.3 Air Drying.**

System must include an air dryer of the desiccant type capable of drying the air to a dew point of minus 40 degrees F. Designers must consider:

9-5.13.3.1 Desiccant dryers are capable of drying the air to a dew point as low as minus 40 degrees F, which may be considered too low for some medical applications.

When required by the Using Agency, the design must include specification of equipment accessories that must permit upward adjustment of air moisture to the required dew point.

9-5.13.3.2 To improve the efficiency of a desiccant dryer system, a refrigerated dryer may be used to precondition the intake air to the desiccant dryer. When mechanical refrigeration systems are specified, designers must include specification of a cycling feature for all systems under 5 horsepower (hp) to minimize the possibility of icing and moisture carryover. Designers must evaluate whether anticipated flow conditions must require the cycling feature for systems 5 hp and over.

**9-5.13.4 MA Demand.**

System demand must be calculated utilizing the peak flow and simultaneous use data in Table 9-5 as a minimum. The simultaneous use factors must be used with judgment and modified to adapt to special conditions if required.

**Table 9-5 Medical Compressed Air (MA) System Demand<sup>1</sup>**

Space/Equipment	LPM	SCFM	Unit of Count	Usage Factor
<b>Anesthetizing Locations:</b>				
Minor Surgery/Operating Room/Cystology	14 <sup>3</sup>	0.5 <sup>3</sup>	Room	100%
Endoscopy	14	0.5	Room	10%
Trauma	14 <sup>3</sup>	0.5 <sup>3</sup>	Room	25%
Veterinary Surgery	14	0.5	Room	50%
Radiology	14	0.5	Room	10%
<b>Ambulatory Care Locations:</b>				
Recovery Room (PACU)	57 <sup>3</sup>	2 <sup>3</sup>	Bed	25%
ICU/Cardiac Care Unit (CCU)	57 <sup>3</sup>	2 <sup>3</sup>	Bed	50%
Emergency Room (ER)/Triage	57	2	Bed	10%
Neonatal ICU	42	1.5	Bed	75%
Dialysis Unit	14	0.5	Bed	10%
Postpartum Recovery	57 <sup>3</sup>	2 <sup>3</sup>	Bed	25%
Infant Resuscitation (within Nursery)	14	0.5	Bed	50%
Pediatrics ICU	57	2	Bed	50%
<b>Subacute Care Locations:</b>				
Nursery	14	0.5	Room	25%
Patient Rooms	10	0.35	Room	10%



<b>Space/Equipment</b>	<b>LPM</b>	<b>SCFM</b>	<b>Unit of Count</b>	<b>Usage Factor</b>
Exam/Treatment	30	1	Room	10%
Pre-Op Holding	42	1.5	Outlet	10%
Respiratory Care/Therapy	28	1	Each	50%
Pulmonary Function Lab	30	1	Outlet	50%
EEG and ECG	30	1	Outlet	50%
LDR and LDRP	28	1	Room	50%
Animal Research	25	1	Room	25%
Blood Donors	10	0.35	Station <sup>2</sup>	10%
Cast Room	14	0.5	Room	10%
Airborne Infection Isolation Room and Protective Environment Rooms	30	1	Bed	10%
Observation (within ER)	30	1	Bed	10%
Pediatric/Adolescent Bedroom	14	0.5	Bed	10%
<b>Other:</b>				
Anesthesia Workroom	30	1	Room	10%
Respiratory Care Workroom	30	1	Station <sup>2</sup>	10%
Nursery Workroom	30	1	Room	10%
Equipment Repair	42	1.5	Outlet	10%
Med. Laboratory	42	1.5	Outlet	25%
This is a generic listing that must be applied to the specific room functions listed in Appendix B Architectural and Engineering Design Requirements.				
Demand rate is per patient care station or technician workstation as applicable.				
Provide an additional 75 LPM (2.6 SCFM) for each ventilator as established by the Using Agency. Provide for not less than 2 ventilators per Operating Room and Recovery Room. Provide for not less than 1 ventilator for all other spaces.				
LPM = liters per minute SCFM = standard cubic feet per minute				

**9-5.14 Dental Compressed Air (DA).**

A centrally-piped DA system with two or more compressors and other components described herein must be provided in accordance with NFPA 99. DA must be used for drying applications during dental procedures and as a power or drive source for lifts, locks, and pneumatic dental instruments and equipment. DA, unlike MA, is not used for breathing or respiratory support of any kind and must not be used to satisfy MA requirements. Air that is normally used for dental laboratory restorative and fabrication techniques may be provided by the DA system.

**9-5.14.1 Air Quality Standard.**

System must include an air dryer of the desiccant type capable of drying the air to a dew point of minus 40 degrees F. Intake air must be direct from outdoors or of quality better than outside air, e.g., pre-filtered outdoor air or relieved return air.

**9-5.14.2 DA Components.**

DA must be provided by two or more equally sized compressors, with provisions for automatic, alternating, and simultaneous operation. Each compressor must be sized such that if any one compressor fails, the remaining compressor(s) must provide 65 percent of standard demand. Provide an alarm to indicate compressor failure that annunciates to the master medical gas alarm panel. All system components downstream of compressors must be sized for maximum combined compressor output. In-line pressure regulators must be provided when DA and dental LA systems are served by a common compressor. Each laboratory supply main must have a pressure regulator. Dryer type must be desiccant.

**9-5.14.3 DA System Demand.**

The system must be sized using these criteria:

**Equation 9-1.** Select a DTR Usage Factor:

<u>Number of DTR Chairs</u>	<u>DTR Usage Factor (DUF)</u>
1–3	1.0
4–6	0.9
7–12	0.8
13–19	0.7
20 and up	0.6

**Equation 9-2.** DTR Demand = No. of DTR chairs X 1.42 L/s X DUF

**Equation 9-3.** Select a lab usage factor:

<u>Number of Technicians</u>	<u>Lab Usage Factor (LUF)</u>
1–5	0.6
6–10	0.5
11–19	0.4
20 and up	0.3

**Equation 9-4.** Lab Demand =

No. of Technicians X 0.472 L/s X LUF  
 + No. of sand/shell blasters X 1.888 L/s X LUF  
 + No. of air chisels X 1.415 L/s X LUF  
 + No. of denture presses X 0.472 L/s X LUF

+ No. of micro-blasters X 2.831 L/s X LUF

+ No. of high speed hand pieces X 1.415 L/s X LUF

**Equation 9-5.** Sterilization demand = No. of hand piece purge stations X 0.472 L/s

**Equation 9-6.** Standard demand = DTR demand + Lab demand + Sterilization demand

**Equation 9-7.** Select the optimum compressor grouping:

COMPRESSOR GROUPING

<u>Type</u>	<u>System Usage Factor (SUF)</u>
Duplex	0.65
Triplex	0.33
Quadplex	0.25

**Equation 9-8.** Compressor size = SUF X Standard demand

**Equation 9-9.** The receiver must be sized based on Table 9-6

**Table 9-6 Receiver Size**

Number of DTR Chairs	Gallons per DTR Chair
1-6	10
7-9	9
10-12	8
13-15	7
16-18	6
19-21	5
>21	4

**9-5.15 Laboratory Air (LA).**

The medical or dental LA system must be a centrally-piped system consisting of two or more compressors and a central receiver, all conforming to the requirements of NFPA 99.

**9-5.15.1 Air Quality Standard.**

Air compressors used for LA must be specifically designed and manufactured for this purpose. LA quality must be in accordance with the DA requirements defined in 9-5.14.1 Air Quality Standard. Intake air must be direct from outdoors or of a quality better than outside air, e.g., pre-filtered outdoor air or relieved return air.

**9-5.15.2 LA System Components.**

LA must be provided by two equally sized compressors with provisions for automatic, alternate, and simultaneous operation. Each compressor must be sized to provide 65 percent of maximum demand. Provide an alarm to indicate compressor failure that annunciates to the master medical gas alarm panel. All system components downstream of compressors must be sized for maximum combined compressor output. A DA generator package used to service an LA system must be supplied by a dedicated main located just downstream of the final package component and inside the equipment room.

**9-5.15.3 LA System Demand.**

Determine the LA system flow demand by the number of work stations and their function plus the requirements for laboratory equipment. The Using Agency must provide this information. The designer in conjunction with the Design and Construction Agent must establish the flow rates. Medical LA system flow rate demand must be 1 cubic foot per minute (CFM) (0.5 liters per second [L/s]) per outlet. Dental LA system flow rate demand is determined by the sizing procedure shown in 9-5.14.3 DA System Demand. The simultaneous use factors must be as listed in Table 9-7.

**Table 9-7 Medical Laboratory Air (LA) System Demand**

No. of Outlets	Use Factor	Minimum L/s (CFM)
1-2	100	
3-12	80	1.4 (3)
13-38	60	4.7 (3)
39-115	40	11.8 (25)
116-316	30	23.6 (50)
317-700	20	44.8 (95)

**9-5.16 Instrument Air (IA).**

An IA system is intended to be used to power medical devices not related to human respiration, e.g., to power surgical tools, surgical arms, and surgical columns. This system may be utilized in lieu of a high pressure piped nitrogen (N) system. The Using Agency in conjunction with the Design and Construction Agent must identify IA requirements. IA must not be used to satisfy medical air requirements. IA systems must be designed in accordance with the requirements of NFPA 99.

**9-5.16.1 Air Quality Standard.**

Air compressors used for IA must conform to the requirements of NFPA 99. IA quality must be as defined in NFPA 99. System must include an air dryer of the desiccant type

capable of drying the air to a dew point of minus 40 degrees F. Intake air must be direct from outdoors or of a quality better than outside air, e.g., pre-filtered outdoor air or relieved return air.

### **9-5.16.2 IA System Components.**

The number of compressors for an IA system must be a function of the application; however, at least two compressors must be provided. For stand-alone clinics, one compressor with a standby header may be provided. Coordinate the compressor arrangement with the Design and Construction Agent. The compressors must be sized such that if any one compressor fails, the remaining compressor(s) must provide 100 percent of maximum system demand. Provide an alarm to indicate compressor failure that annunciates at the master medical gas alarm panel. All system components downstream of the compressors must be sized for 100 percent standard system demand and be duplexed. The receiver must have an automatic drain feature and must be sized per manufacturer recommendation.

### **9-5.16.3 IA System Demand.**

The number of workstations and their functions plus the requirement of any equipment must determine the IA system flow demand. The piping system must be suitable to deliver 15 CFM (7 L/s) per outlet, with a demand usage factor of 100 percent. System capacity must be determined using these equations:

$$\text{Capacity} = 350 \text{ LPM} + ([n-1] \times 87.5 \text{ LPM}) \text{ or}$$

$$\text{Capacity} = 12 \text{ SCFM} + ([n-1] \times 3 \text{ SCFM})$$

*Where:* n = number of locations or tools

LPM = liters per minute

SCFM = standard cubic feet per minute

### **9-5.17 Process Air (PA).**

PA may be a centrally-piped system when warranted by the application, e.g., medical service column adjustment, shop operations, door operators. The Using Agency, in conjunction with the Design and Construction Agent, must identify PA requirements. When approved by the Design and Construction Agent, LA or IA may be used to satisfy PA requirements. PA is not required to be oil free, but must be suitable for the application as recommended by the equipment manufacturer.

### **9-5.18 Medical Surgical Vacuum (MV) System.**

The MV system must be a centrally-piped, dry vacuum system containing two or more continuous duty pumps with a central receiver. The system must meet the requirements of NFPA 99 and must be sized so that if one pump fails, the remaining pump(s) can supply 100 percent of the total system demand. The system design must

include automatic operation of the vacuum pumps including alternating lead and lag status. Provide an alarm to indicate vacuum pump failure that annunciates to the master medical gas alarm panel. Refer to Table 9-8.

**Table 9-8 Medical Vacuum Source Sizing**

Occupancy/Location	Diversity Factor	High Demand
<b>Anesthetizing Locations:</b>		
Special Surgery and Cardiovascular	A	Y
Major Surgery and Orthopedic	A	Y
Minor Surgery/Cystology	A	Y
Endoscopy	A	N
Trauma	A	Y
Veterinary Surgery	A	Y
Radiology	B	N
Cardiac Catheterization	A	Y
<b>Ambulatory Care Locations:</b>		
Recovery Room (PACU)	A	N
ICU/CCU	A	N
Emergency Room (ER)/Triage	A	Y
Neonatal ICU	A	N
Dialysis Unit	A	N
Postpartum Recovery	A	N
Infant Resuscitation (within Nursery)	A	N
Pediatrics ICU	A	N
<b>Subacute Care Locations:</b>		
Nursery	A	N
Patient Rooms	B	N
Decontamination Station	B	N
Exam/Treatment	B	N
Pre-Op Holding	B	N
Respiratory Care/Therapy	B	N
Pulmonary Function Lab	B	N
EENT, EEG, ECG, EMG	B	N
LDR & LDRP	A	N
Animal Research	B	N

Occupancy/Location	Diversity Factor	High Demand
Blood Donors	B	N
Cast Room	B	N
Airborne Infection Isolation Rooms and Protective Environment Rooms	B	N
Observation (within ER)	B	N
Pediatric/Adolescent Bedroom	B	N
<b>Other:</b>		
Anesthesia Workroom	B	N
Respiratory Care Workroom	B	N
Nursery Workroom	B	N
Equipment Repair	B	N
Med. Laboratory	B	N

### 9-5.18.2 Applications.

The MV must be used only for medical functions involving patient care, therapy, and diagnostic functions as described here. It may also serve DSV requirements for DTRs and oral surgeries, and small laboratories in patient care areas that function in direct support of medical functions. Analysis, research, or teaching laboratories located within an MTF may also be served by the MV, provided that a separate system connection or main is located at the vacuum receiver, with a shut-off valve and trap with a drain valve. Laboratories not supporting medical functions must have a vacuum system separate from the MV.

### 9-5.18.3 Demand.

Size vacuum system pumps and piping in accordance with these equations:

$$\text{Demand Medical Vacuum} = \text{Demand}_A + \text{Demand}_B + \text{Demand}_C$$

Where:  $\text{Demand}_A = \# \text{ Inlets for Diversity Factor A} \times 0.25 \text{ SCFM/inlet} \times \text{Diversity Factor A}$

$\text{Demand}_B = \# \text{ Inlets for Diversity Factor B} \times 0.25 \text{ SCFM/inlet} \times \text{Diversity Factor B}$

$\text{Demand}_C = \# \text{ Rooms with High Demand} \times 1.5 \text{ SCFM/room}$

It is important to note that  $\text{Demand}_A$  and  $\text{Demand}_B$  have a diversity factor determined by Figure 9-1, whereas  $\text{Demand}_C$  assumes no diversity (factor of 1.0).

For example, the demand for a medical vacuum system for five ORs would be calculated using these equations:

$$\text{Demand Medical Vacuum} = \text{Demand}_A + \text{Demand}_B + \text{Demand}_C$$

Where: Demand<sub>A</sub> = 12 medical vacuum inlets per OR per Appendix B X 5 ORs X 0.25 SCFM/inlet X 0.97 Diversity Factor for 60 inlets with "A" Diversity Factor = 14.55 SCFM

$$\text{Demand}_B = 0$$

$$\text{Demand}_C = 5 \text{ Rooms with High Demand} \times 1.5 \text{ SCFM/inlet} \\ = 7.5 \text{ SCFM}$$

$$\text{Medical Vacuum Demand} = 14.55 + 0 + 7.5 = 22 \text{ SCFM}$$

**Figure 9-1 Simultaneous Use Factors for Medical Vacuum**

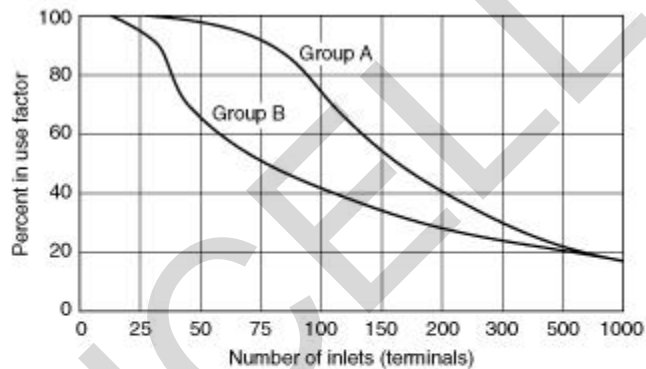

Note 1: If the medical-surgical vacuum system is to be used for the disposal of waste anesthetic gases, caution must be taken to ensure that the system is designed for the additional volume required. It is recommended that 4-3.3.1, Waste Anesthetic Gas Disposal, be consulted as well. It is essential that the design team consult with medical and hospital staff when determining the minimum number of station inlets.

Note 2: It should be understood that the percentage in use factors obtained from this figure represent an average hospital. Hospitals with heavier-than-average use can require higher use factors.

1. This graph is adapted from 1999 version of NFPA 99.
2. It is understood that percentage in use factors represent a typical hospital and may need to be increased, but must not be decreased without approval from the Design and Construction Agent.

#### **9-5.18.4 Inlets.**

The intended use of "Y-connectors" as a means of increasing available inlets is not recommended. A justified need for a vacuum inlet must be accommodated with another wall inlet, not a Y-connector. Verify with the Using Agency that the number of vacuum inlets proposed must support the planned medical function operation without the use of Y-connectors.



**9-5.18.5 Performance.**

System pressure drop must be a maximum of 3 inches of mercury (in-Hg) (10 kilopascals [kPa]) at the calculated demand flow rate. A flow rate of 3 SCFM (1.4 L/s) per inlet, with no equipment attached, must be measured while maintaining 12 in-Hg (41 kPa) vacuum at the farthest inlet. (3 SCFM [1.4 L/s] without equipment is equivalent to the recommended 1.5 SCFM [0.7 L/s] with equipment.)

**9-5.18.6 Slide Brackets.**

Vacuum bottle slide brackets must be provided for all medical vacuum inlets. Vacuum bottles must be used at all vacuum inlets to prevent liquids and solids from entering the piping network. Vacuum bottles must be provided with an overflow shut-off device to prevent carryover of fluids or solids into the piping system. Brackets must be positioned to provide proper clearance for flow meters and adapters and to eliminate conflict with electrical receptacles. Thus, it is recommended that the vacuum outlet be located at either end of a group of medical gas outlets, with the slide bracket to the outside, e.g., in a healthcare station head wall unit. If two vacuum inlets are required at a given station, locate one at each end of the outlet group with the slide brackets to the outside. It is critical to coordinate vacuum inlet and slide locations with the designer and the Using Agency to avoid interference with other items without compromising the medical function.

**9-5.18.7 Exhaust**

Exhaust the medical vacuum system in accordance with NFPA 99 but do not combine with any other system exhaust.

**9-5.18.8 Filtration**

Provide inlet filtration on central supply systems per NFPA 99. Filters must be sized for 100 percent of peak calculated demand while one filter or filter bundle is isolated. Ensure adequate space is provided at filters to allow clearance for maintenance personnel to access filter housings to replace filter elements.

**9-5.19 Dental Surgical Vacuum (DSV).**

A central DSV system may be supplied for areas in dental clinics where MV is required as specified in Appendix B Architectural and Engineering Design Requirements. This system is also a dry system with a centrally-piped distribution system and receiver; no liquids or solids must be transported in the distribution system. Individual separators must be located in each applicable DTR. The system must consist of two or more vacuum pumps and a central receiver. The system must be sized so that upon failure of one pump, the remaining pump(s) must maintain the minimum vacuum specified while providing 100 percent of the calculated demand. The system design must include automatic operation of the vacuum pumps including alternating lead and lag status. Provide an alarm to indicate vacuum pump failure that annunciates to the master medical gas alarm panel. For dental clinics located in a hospital, the MV system may be used in lieu of a DSV system.

**9-5.19.1 Performance.**

A minimum vacuum of 19 in-Hg (65 kPa) must be maintained at the receiver. System pressure drop must be such that the most remote inlet must have a minimum vacuum of 12 in-Hg (41 kPa) under peak demand conditions. System pressure drop must be a maximum of 3 in-Hg (10 kPa) at the calculated demand flow rate.

**9-5.19.2 Demand.**

Calculate system demand based on 2 SCFM (0.9 L/s) for each DTR DSV inlet with the demand factors in Table 9-9:

**Table 9-9 DSV Demand Factors**

No. of DTR DSV Inlets	Use Factor
1–6	1.0
7–10	0.8
>10	0.6

9-5.19.3 Exhaust the Dental Surgical Vacuum system in accordance with NFPA 99 but do not combine with any other system exhaust.

**9-5.20 Oral Evacuation (OE).**

A central low vacuum, high volume OE system must be installed in dental clinics to provide scavenging, collection, and disposal of liquids, solids, and aerosols from dental procedures. This is a wet system with liquids and solids transported through wetted piping from the collection point to one or more liquid or air separator tanks located upstream of two or more vacuum pumps. The tank serves as a collector for the fluids and solids and provides a means of automatic draining by indirect connection to the sanitary sewer. The tank draining system must include an automatic wash down feature for larger systems in an MTF having greater than 10 DTR chairs. The vacuum pumps must be sized so that when one pump is inoperable, the remaining pump(s) must provide the required vacuum pressure and fluid flow for a minimum of 70 percent of the system demand. The system design must include automatic operation of the vacuum pumps including alternating lead and lag status. Provide an alarm to indicate vacuum system fault, e.g., pump failure, which annunciates to the master medical gas alarm panel. Protocol must include alarm initiation when a pump is not appropriately operating.

**9-5.20.1 Components.**

The service inlet normally is floor mounted in a utility center at the dental chair, or wall mounted with a means of connection to clinical end items, such as the high volume hose. The separator(s) must receive all liquid, air, and solids upstream of vacuum pump(s). Liquids and solids must be discharged from the separator(s), with piped

gravity flow through an air gap into a trapped and vented receptor, e.g., floor drains, sinks, standpipe receptors for small system suspended tank installations, connected to the sanitary waste system. Amalgam separators must be provided IAW paragraph 9-3.8 Mercury Control and must be configured centrally for a single point of collection at the vacuum producers. Additional point-of-use collection may be utilized where requested by the Using Agency. The liquid/solid separator tank must discharge a minimum of once during a 24-hour interval for a one-tank system, when a high liquid level sensor activates for a two-tank system, or multiple daily discharges as recommended by the manufacturer. Separator overflow protection must be included to protect during periods of abnormal usage or when the automatic discharge malfunctions.

#### **9-5.20.2 Performance.**

The system operating range must be 6–8 in-Hg (21–27 kPa). A minimum vacuum of 6 in-Hg (21 kPa) must be maintained at the farthest inlet. System pressure drop must be a maximum of 1 in-Hg (3 kPa) at the calculated demand flow rate. A flow rate of 7 SCFM (3.3 L/s) per inlet must be measured while maintaining 6 in-Hg (21 kPa) at the farthest inlet.

#### **9-5.20.3 Demand.**

Calculate the system demand based on 7 SCFM (3.3 L/s) per inlet-nozzle orifice. The demand usage factor is normally 100 percent. Verify the specific usage factor with the Design and Construction Agent.

#### **9-5.20.4 Separator Tank.**

The separator and collector tanks must be sized per manufacturer recommendations but must be a minimum of 2.75 gallons (10.45 liters) per DTR chair. Multiple tanks must be provided for more than 20 chairs and must be considered for 20 or fewer chairs if continuous operation is necessary. Tank drainage piping must slope from the tank discharge point down to the discharge point at the floor drain or standpipe receptor.

#### **9-5.20.5 Equipment Location.**

The OE equipment must be located below the DTR floor level. Locate the separator tank adjacent to or stacked with the vacuum pump. Size the pipe to maintain system pressure loss within the maximum limit. The tank drain valve discharge must be a minimum 0.5 foot above the floor to accommodate the pipe slope, drain line turndown, and the indirect connection air gap to the sanitary drainage system receptor. The sanitary waste centerline of pipe must be a minimum 1 foot below the floor to accommodate the floor drain trap. The equipment room must be located as near the DTRs as possible to minimize distribution piping bends and pipe length. Equipment placement in the mechanical room must be arranged to provide the most direct connection to the distribution piping, the sanitary waste line, and the exhaust discharge point, in that order.

#### **9-5.20.6 Piping Distribution.**

The piping run from the dental utility center should continuously slope back to the vacuum source equipment with limited rise, to facilitate transportation of fluids and particulate. Minimum required slope is 1/4 inch per 10 feet. Distribution system piping must be a minimum 2 inches in diameter. Where maintenance access is required, piping must be installed in accessible locations in covered trenches, tunnels, or crawl spaces. Provide cleanout fittings at every change of direction greater than 45 degrees. Minimum access space must be 2 feet minimum to within 2 feet of the cleanout and a minimum 6 inches from this point to the cleanout. Specify DWV fittings to facilitate movement of solids. Enlarging the pipe size must be considered depending upon availability of the DWV fittings and relative pipe costs. When overhead pipe routing cannot be practicably avoided, provide cleanout fittings at the base of all risers and observe these requirements:

- a. Minimize lift height.
- b. Vertical pipe run from inlet to overhead pipe must be 1/2-inch diameter or in accordance with manufacturer's recommendation.
- c. The vertical pipe must "tee" into the top of the overhead branch main.
- d. The available vacuum level to satisfy performance requirements stated in paragraph 9-5.20.2 Performance must be based on a reduction of the pump-generated vacuum at the rate of 1 in-Hg for each 1.1 foot rise.

#### **9-5.20.7 Exhaust.**

The exhaust pipe material and size, including the connection to the equipment discharge point, must be in accordance with manufacturer's recommendation. The number of bends and total length must be minimized. The exhaust piping must be a dedicated run from the equipment connection to the discharge point outside the MTF, sloping back to the equipment and must not be connected to any other system exhaust. The exhaust discharge must be protected from backflow of air or liquids by detailing an appropriate discharge arrangement, such as a gooseneck or shroud with screen with a check valve, or using a flapper valve approved by the manufacturer. The discharge point must be separated a minimum of 33 feet from the DA or MA system intake and any HVAC system outdoor air intake.

#### **9-5.21 High-Volume Laboratory Dust Evacuation (LDE).**

The LDE system must scavenge and centrally separate, filter, and collect material trimmings, grinding debris (toxic and nontoxic), and particulates from polishing and finishing operations in the dental laboratory. Point-of-use dust collection may be provided for some operations per Using Agency requirements.

**9-5.21.1 System Components.**

The LDE system for dental laboratories must consist primarily of one belt-driven vacuum pump complete with a preset, field-adjustable ingestion valve, exhaust silencer, and a central cyclonic separator with a filter bag system.

**9-5.21.2 Performance.**

The vacuum at the farthest inlet must be a minimum of 1.25 in-Hg (4.2 kPa). A flow rate of 60 SCFM (28 L/s) per technician work station inlet and 150 SCFM (71 L/s) per equipment item inlet must be measured while maintaining the 3 in-Hg (10 kPa) at the separator. Verify the equipment requirements with the Using Agency.

**9-5.21.3 Demand.**

The system demand must be calculated based on the inlet flow rate requirement. Apply the usage factor values shown in Table 9-10 for the given number of inlets.

**Table 9-10 LDE System Utilization Factors**

Lab Size (# of inlets)	Usage Factor ( percent)	Separator Filter (square feet)
1-4	100	60
5-10	80	120
11-15	70	160
16-24	60	220

**9-5.22 Waste Anesthesia Gas Disposal (WAGD).**

The WAGD system must be a centrally-piped, dry vacuum system containing two or more continuous duty pumps with a central receiver. It must meet the requirements of NFPA 99 and be sized so that if one pump fails, the remaining pump(s) can supply 100 percent of the total system demand. The system design must include automatic operation of the vacuum pumps including alternating lead and lag status. Provide an alarm to indicate vacuum pump failure that annunciates to the master medical gas alarm panel.

For Veterinary Facilities, the design vacuum pressure must be carefully evaluated and established in coordination with the intended anesthetizing equipment and include provisions for pressure/flow rate adjustment and visual monitoring at each inlet.

**9-5.22.1 Applications.**

WAGD must be incorporated into the MTF design. A dedicated WAGD system must be provided in accordance with NFPA 99. When permitted by NFPA 99, the DSV system may be used for WAGD in dental clinics. Inlets must be provided in anesthesia

locations. Verify that the system vacuum pump is suitable for the high oxygen and nitrous oxide exhaust content associated with anesthetizing procedures.

#### **9-5.22.2 Demand and Performance.**

Base design on a demand of 1.8 SCFM (50 LPM) per patient care station except for veterinary care which must be based on a demand of 0.18 SCFM (5 LPM) per patient care station.

#### **9-5.22.3 Exhaust**

Exhaust the WAGD system in accordance with NFPA 99 but do not combine with any other system exhaust.

#### **9-5.23 Oxygen (O).**

Oxygen (O) is used in the gaseous state to sustain life through direct delivery to the patient. Oxygen can be stored as a gas in cylinders or as a liquid in bulk tanks. It is classified as a nonflammable gas and oxidizer; it can increase the range of flammability of other materials and gases when present in sufficient concentration. Its storage requires proper construction and ventilation in accordance with NFPA 99 and NFPA 55. The oxygen system must not be used to supply non-patient uses, including equipment in laboratories or medical equipment maintenance and repair shops. Separate point-of-use services must be used for such non-patient applications.

#### **9-5.23.1 Provision of Central Systems.**

When more than five outlets are provided and used on a routine basis, central oxygen storage and distribution systems must be provided, such as is typically the case with medical centers, hospitals, and large Ambulatory Healthcare Centers. Point-of-use ("roll-in") cylinders should be utilized for clinical applications involving few oxygen outlets and infrequent utilization.

#### **9-5.23.2 Emergency Connection.**

Provide an emergency oxygen supply connection on the building exterior when the oxygen supply system is located outside the building. This connection must be used as a temporary auxiliary source of supply. Valves and pressure control devices must be in accordance with NFPA 99.

#### **9-5.23.3 System Demand.**

The piping system must be designed to deliver 0.7 CFM (20 LPM) at the outlet, utilizing a 100 percent usage factor for outlets in Critical Care Areas and factors for outlets in other areas as defined in Table 9-11. Historical usage data from replaced or similar MTFs may be used as a guideline when determining system demand instead of the method presented in 9-5.23.4, Storage Capacity Sizing Method. Reference 9-5.23.5, Liquid Bulk-Tank Storage, for additional design considerations for determining the required capacity of liquid bulk tanks.

**Table 9-11 Oxygen System Utilization Factors**

Number of Outlets	Percent Usage (%)
1-3	100
4-12	75
13-20	50
21-40	31
41-80	25
81 or more	15

**9-5.23.4 Storage Capacity Sizing Method.**

In the absence of available historical oxygen consumption data, Table 9-12 must be used in estimating required system storage capacity for MTFs having large inpatient populations, e.g., hospitals, medical centers. For facilities with predominantly outpatient functions, designers must work with the Using Agency to estimate consumption rates and appropriate storage capacities.

**Table 9-12 Cylinder Manifold Systems**

Number of Beds	Minimum Number of Cylinders <sup>1 2</sup>
1-50	8
51-75	12
76-100	16
101-125	20
126-150	24
1 Per bank of "H" cylinders	
2 Study must be performed that includes an analysis of an appropriate diversity factor and the cost-effective option between cylinder and bulk storage.	

**9-5.23.5 Liquid Bulk-Tank Storage.**

Designers must coordinate with the Using Agency to consider the economic aspects of storage capacity. Excessive capacity translates to higher utilization costs due to boil off. Tank must be sized to account for boil off. Too little capacity may lead to higher costs because of more frequent tank refills, which includes vented oxygen cost as well as delivery fees. Designers must also consider the availability of an oxygen refill service. For remote locations, oversized capacity may be more practical and economical to minimize deliveries and provide for unexpected consumption increases. The selection between purchasing or leasing the bulk storage tank and ancillary equipment must be

coordinated. Economic and logistic factors relative to the given supplier(s) must be considered. Underground piping must be protected in a concrete or steel pipe enclosure. Consider provisions for future replacement of piping. The standard tank sizes are shown in Table 9-13.

**Table 9-13 Oxygen Bulk Tank Sizes**

<b>Liters</b>	<b>Gallons</b>
1,895	500
5,680	1,500
11,355	3,000
22,710	6,000
34,065	9,000
41,635	11,000
49,205	13,000
68,130	18,000
75,700	20,000

**9-5.23.6 System Monitoring.**

The central oxygen system design must facilitate oxygen system purity monitoring with an outlet placed in the biomedical maintenance area, or other area, as directed by the Design and Construction Agent. This outlet must be upstream (on the source side) of other oxygen outlets.

**9-5.24 Nitrous Oxide (NO).**

Nitrous oxide is an anesthetic gas capable of inducing the first and second stages of anesthesia when inhaled. It is classified as a nonflammable gas; however, it can increase the range of flammability of other materials and gases when present in sufficient concentration. Its storage requires proper construction and ventilation in accordance with NFPA 99. Nitrous oxide manifolds must not be located outside in cold climates due to the low vapor pressure of nitrous oxide at low temperatures.

**9-5.24.1 System Demand.**

The piping system must be designed to provide for a demand of 0.7 CFM (20 LPM) per patient care station. The system manifold must be sized to provide a minimum of 1/2 cylinder per week per patient care station (based on H-size cylinders). The minimum number of cylinders per header must be two.

**9-5.25 Nitrogen (N).**

Nitrogen is an inert gas primarily used as an operating or driving means for medical and dental hand pieces and equipment. This system may be utilized in lieu of the IA



system. The number of outlets must be the same as depicted for IA in Appendix B Architectural and Engineering Design Requirements. The cylinder manifold system must be designed and installed in accordance with NFPA 99.

#### **9-5.25.1 Control Cabinet.**

Each individual nitrogen use location, e.g., individual OR, DTRs, must be provided with a nitrogen control cabinet with pressure gauges and pressure regulating valves for the purpose of independently regulating pressures at that location.

#### **9-5.25.2 Demand.**

The piping system must be suitable to deliver 15 CFM per outlet, with a demand usage factor of 100 percent. The system manifold must be sized to provide a minimum of 2 cylinders per week per orthopedic or neurosurgery OR and 1 cylinder per week per all other anesthetizing locations (based on H-size cylinders). The minimum number of cylinders per header must be two.

#### **9-5.26 Carbon Dioxide (CO<sub>2</sub>).**

Carbon dioxide is used during laparoscopic procedures to facilitate the insertion of surgical instruments into the body. It is pumped into the body to create space between the muscles and the organs, providing the surgeon a clear view of the area to be operated. Carbon dioxide is above its triple point under ordinary conditions of storage and is actually a liquid in the cylinders (but not a cryogenic liquid). It is classified as a nonflammable gas and its storage requires proper construction and ventilation in accordance with NFPA 99. The cylinder manifold system must be designed and installed in accordance with NFPA 99. Carbon dioxide manifolds must not be located outside in cold climates due to the low vapor pressure of CO<sub>2</sub> at low pressure.

Design the piping system to provide a minimum demand of 2.0 CFM per outlet with a 100 percent usage factor. In determining the storage capacity, designers must evaluate the CO<sub>2</sub> demand of the equipment intended for each facility and in consultation with the Using Agency. At a minimum, the system manifold must be sized to provide a 1/2 cylinder per medical location (based on H-size cylinders). The minimum number of cylinders per header must always be two.

#### **9-5.27 Process Gas.**

Process gas is natural or propane that is used as a point-of-use heat or flame source. The process is typically found in laboratories and sometimes in other areas, such as equipment repair and DTRs, to support medical or dental functions. The gas system design must be in accordance with NFPA 54 and 58.

9-5.27.1 The load is the sum of the consumption rates for the given apparatus or equipment to be serviced. Laboratory burners are typically sized at 1465 watts (W) (5,000 British thermal unit per hour [Btuh]) for small burners and 3075 W (10,500 Btuh) for large burners. For other equipment, such as casting ovens, use manufacturer's data.

9-5.27.2 Demand is based upon the number of outlets shown in Table 9-14.

**Table 9-14 Process Gas Utilization Factors**

<b>Number of Outlets</b>	<b>Percent Usage (%)</b>
1-8	100
9-16	90
17-29	80
30-79	60
80-162	50
163-325	40
326-742	35
743-1570	30
1571-2900	25
>2900	20

CANCELLED

## CHAPTER 10 HEATING, VENTILATION, AND AIR CONDITIONING

### 10-1 GENERAL.

This chapter provides HVAC design requirements for Military Medical Facilities. The primary requirement of the HVAC system(s) in a Military Medical Facility is the support of medical function and the assurance of occupant health, comfort, and safety. The HVAC system functions not only to maintain minimum requirements of comfort and ventilation, but is an essential tool for the control of infection, removal of noxious odors, dilution and expelling of contaminants, and establishment of special environmental conditions conducive to medical procedures and patient healing. Subject to these requirements, appropriate consideration must be given to the HVAC design to ensure system maintainability, economics and energy efficiency, and adaptability to future facility modification or expansion.

#### 10-1.1 Applicability.

This criterion applies to new and existing Military Medical Facilities. Applicability to existing facilities is restricted to upgrade or replacement projects, and for those specific systems or services included in the scope of the project authorization. For existing facilities, when complete compliance with the technical criteria of this chapter is not economically practicable, consideration must be given to substitution of other recognized industry standards or criteria upon application to DHA/FE as provided under Chapter 3 Design. All facilities must comply with the applicable standards of the NFPA.

#### 10-1.2 Supporting Documents.

This guidance may be supplemented by Design and Construction Agent, and Using Agency publications, including project specific Medical Design Instructions, UFCs, Technical Manuals, ETLs, and other criteria. Minimum HVAC design criteria must be in accordance with the latest editions of the ASHRAE *Handbook* series, the American Conference of Governmental Industrial Hygienists (ACGIH) publication *Manual of Recommended Practices for Industrial Ventilation*, and NFPA Standards 45, 90A, 96, 99, 101, and 801, as well as applicable governmental regulations. Other industry and Government standards must be utilized for HVAC design as applicable.

### 10-2 DESIGN CONDITIONS.

#### 10-2.1 Weather Data.

Weather data must be obtained from UFC 3-400-02. If given Military Installations have access to more recent or accurate information of weather conditions in their region, designers must coordinate use of this information with the Design and Construction Agent.

#### 10-2.2 Interior Design Conditions.

Interior design conditions must be in accordance with Appendix B Architectural and Engineering Design Requirements or as otherwise addressed in this chapter.

### **10-2.3 Space Ventilation.**

Minimum total and outside air change rates must be in accordance with Appendix B Architectural and Engineering Design Requirements. Supply higher air change rates as required to meet air conditioning or make-up air requirements as supported by engineering calculations. See 10-16, Ventilation Design, for additional guidance and requirements.

### **10-2.4 Ambient Outdoor Design Conditions.**

#### **10-2.4.1 Facilities Housing Critical Care and Other Inpatient Services.**

- a. Design the HVAC cooling based on the largest of the three following Total Cooling (BTU/HR) conditions: the 0.4 percent dry bulb temperature, and corresponding mean coincident wet bulb temperatures; the 0.4 percent wet bulb temperature and corresponding mean coincident dry bulb temperature; and the 0.4 percent humidity ratio and corresponding mean coincident dry bulb temperature.
- b. Design the heating based on the 99.6 percent dry bulb temperature.
- c. Design the cooling tower evaporation rate based on the 0.4 percent wet bulb temperature.
- d. Design humidifiers based on the 99.6 percent humidity ratio and corresponding mean coincident dry bulb temperature.

#### **10-2.4.2 Outpatient Facilities Not Housing Critical Care.**

- a. Design the HVAC cooling based on the largest of the three following Total Cooling (BTU/HR) conditions: the 1.0 percent dry bulb temperature and corresponding mean coincident wet bulb MCWB temperature; the 1.0 percent wet bulb temperature and corresponding mean coincident dry bulb temperature; and the 1.0 percent humidity ratio and corresponding mean coincident dry bulb temperature
- b. Design the heating based on the 99 percent dry bulb temperature.
- c. Design the cooling tower evaporation rate based on the 1.0 percent wet bulb temperature.
- d. Design humidifiers based on the 99 percent humidity ratio and corresponding mean coincident dry bulb temperature.

### **10-2.5 Critical Care Spaces.**

Critical Care Spaces are identified in Appendix B.

### **10-2.6 Laboratories.**

Space design and ventilation requirements for clinical laboratories are indicated in Appendix B Architectural and Engineering Design Requirements. Research laboratories, to include animal holding facilities in research laboratory facilities, must be designed in accordance with the *ASHRAE Handbook of Fundamentals*, the *Biosafety in Microbiological and Biomedical Laboratories*, and *Guide for Care and Use of Laboratory Animals*.

### **10-2.7 Temperature during Smoke Control Operation.**

When a supply air system is required to operate on 100 percent outside air during smoke mode operation, the system must be designed with sufficient heating capacity to maintain a minimum of 45 degrees F at the AHU discharge under the 99.6 percent winter design conditions.

### **10-2.8 Mechanical Equipment Rooms.**

Mechanical equipment rooms must be conditioned as needed to meet the manufacturers recommended conditions for any sensitive electronic equipment, such as variable frequency drives, microprocessor-based controls or circuit breakers, or other electronic components unless those devices are installed in conditioned cabinets. Designer must confirm the requirements of such equipment and consider not only the manufacturers allowable conditions but also the potential degradation of performance within the allowable conditions in determining the room design temperature (e.g., elevated temperatures reduce the life expectancy of backup batteries). Mechanical equipment rooms without temperature sensitive equipment or where that equipment is otherwise installed in a conditioned cabinet must be designed to maintain temperatures within 10 degrees F of summer ambient design temperature. In humid climates, mechanical rooms that are contiguous with the occupied building must be conditioned to a humidity level equivalent to the occupied areas to minimize transfer of moist, unconditioned air to the interior of the building.

### **10-2.9 Humid Climate Definition.**

A humid climate is a region that meets or exceeds both of the cooling load criteria indicated herein. The charts and tables referenced can be found in the region-specific climate data reports entitled Engineering Weather Data (EWD) available from the Air Force Combat Climatology Center as referenced in UFC 3-400-02. Humid climates are defined as regions where the latent load is three times the sensible load AND where the monthly latent load exceeds the monthly sensible load for two or more consecutive months of the year. (Reference data field "Ventilation Cooling Load Index" - EWD page 1 of 18 and graph "Average Ventilation and Infiltration Loads" - EWD page 14 of 18, as referenced in UFC 3-400-02.)

### **10-2.10 NFPA 99 Risk Assessment.**

A Risk Assessment must be performed in accordance with NFPA 99 to establish the System Categories for all HVAC systems. See Appendix C for the timing and responsibilities of the Risk Assessment.

### **10-3 REFRIGERANTS.**

Refrigeration equipment must utilize refrigerant having an Ozone Depletion Potential (ODP) of not greater than 0.0 (refer to the U.S. Environmental Protection Agency [EPA] Significant New Alternatives Program [SNAP] for acceptable refrigerants). Refrigeration room design must include the safety features, such as sensing devices and purge ventilation system, as required for the particular refrigerant in accordance with ASHRAE Standards 15 and 34.

### **10-4 LIFE-CYCLE COST AND ENERGY ANALYSIS.**

Life-cycle cost and energy analysis required in conformance with this chapter, or necessary for the evaluation of building sustainability features or performance, must be in accordance with criteria referenced in Chapter 1 Introduction and Chapter 4 Sustainable Design Principles.

### **10-5 ELIGIBILITY FOR AIR CONDITIONING.**

#### **10-5.1 Total Air Conditioning.**

Air conditioning is required in all normally occupied facilities and spaces to meet the interior conditions listed in Appendix B Architectural and Engineering Design Requirements. "Normally occupied spaces" must include such spaces incidental to Military Medical Facilities as corridors and circulation areas. Normally unoccupied, or intermittently occupied, spaces, such as restrooms, locker rooms, soiled linen rooms, janitors closets, indoor stairwells, and similar spaces accessible to medical staff or the public and having exterior exposure, must be air conditioned (in addition to being provided with the required ventilation) to maintain reasonable conditions.

#### **10-5.2 Food Service Area.**

Design air conditioning of the kitchen areas to minimize energy costs including compliance with ASHRAE 90.1, while providing a reasonably comfortable environment for kitchen staff. Designs must provide for a temperature of not more than 80 degrees F in all cooking and servery areas.

#### **10-5.3 Medical Warehouses.**

Base HVAC design upon the environmental requirements of the stored materials. Spaces within medical warehouses that must be normally occupied, including Administrative or Break Rooms, must be air conditioned as required to provide the design conditions listed in Appendix B Architectural and Engineering Design

Requirements. Air conditioning must also be required for any warehouse spaces housing computer or other environmentally-sensitive equipment.

## **10-6 MECHANICAL EQUIPMENT SPACE.**

### **10-6.1.1 Mechanical Room**

Mechanical rooms for major air handling equipment, heat exchangers, prime movers, medical gas supplies, vacuum and air compressors, and other major mechanical equipment must generally be located within the facilities with access to the outside of the building. Exceptions to locate AHUs in conditioned penthouse equipment rooms may be considered by the Design and Construction Agent if justified from a cost or functionality standpoint, provided that stairwell access, at a minimum, is provided. For multi-story facilities, direct access to rooftop AHU penthouses must be provided from an elevator. Rooftop mounted air handlers must not be used in any new facility in excess of 15,000 gross square feet, except for temporary or deployable facilities, due to the difficulty of maintenance access, and consideration of safety and working conditions for O&M personnel. Mechanical room location and layout must consider:

- a. Sufficiency of space to enable access for operation, maintenance, and replacement of equipment.
- b. Minimization of distribution runs.
- c. Relative location to electrical equipment rooms: NFPA 70 vertical clearance and dedicated space requirements for electrical equipment must restrict or preclude the routing of piping and ductwork through these locations.
- d. Relative location to Communication Rooms: adjacency of fan and Communications Rooms must create congested above-ceiling conditions where cable trays and ductwork converge.
- e. Adjacency to corridors, as a path for the routing of ductwork.
- f. Adjacency to spaces having stringent noise control requirements, or spaces with high ceilings that may restrict duct distribution space.
- g. Potential future expansion of mechanical system capacity.

Equipment rooms must be designed to provide a minimum of 24 inches of clearance on all sides of AHUs. Sufficient access must be provided for removal and replacement of filters, coils, fans, motors, pumps, and other associated equipment, with piping, ductwork, and conduit installed such as not to block the access-way. Unions, flanged fittings, or other readily demountable connections must be provided at equipment piping connections to facilitate removal.

## **10-6.2 Energy Plant**

Chilled water, steam and hot water generators may be located in a separate energy plant. Utility lines connecting the energy plant to the facility must be installed in a tunnel or other accessible enclosure providing maintenance access and protection from the elements. Accessibility must be such that any valves, fittings, or equipment requiring periodic maintenance or inspection must be accessible to workers without using lifting equipment. Accessibility to all other equipment within the enclosure may be accomplished with removable panels or coverings readily accessible to mobile cranes or rigging equipment. Where authorized by the Design and Construction Agent and Using Agency, pre-fabricated direct-buried utility lines with closed-cell foam insulation, integral leak detection, and exterior sheathing may be utilized for water services only (e.g. chilled and heating hot water) provided that all valves or maintenance items are installed in man-holes.

## **10-7 HVAC SYSTEM DESIGN FOR FUNCTIONAL AREAS.**

The primary considerations of the HVAC design are to provide the environmental conditions required to meet the functional requirements. Military Medical Facilities must be primarily served by central-station AHUs using single duct terminal reheat, and variable air volume (VAV), or constant air volume (CAV) terminals, as appropriate for room conditioning and pressure control. Where electric resistance heating is utilized in accordance with UFC 3-410-01, provide with modulating capacity control (i.e. SCR technology). When utilized, VAV systems must be of the pressure independent, minimum air quantity type. Direct Expansion (DX) coils must not be used in VAV systems. Induction-type terminal units (e.g., chilled beams) may be utilized but only to meet sensible loads (i.e., non-condensing) and the air changes induced by these devices may not be counted toward the total air change requirement in Appendix B (see total air change definition in paragraph 10-16.1). With the exception of sensitive equipment spaces; mechanical, electrical, and plumbing (MEP) rooms, all-water (e.g., fan coil units), unitary, and fan-powered VAV systems are not acceptable, due to concerns with maintenance, noise, and limited ability to meet filtration and ventilation requirements.

### **10-7.1 Critical Care Spaces.**

These spaces must normally be served by single-duct terminal reheat systems. Simultaneous temperature, humidity, and pressurization control requirements for these spaces preclude the use of other types of systems. Air handling systems serving Critical Care Spaces must be of the draw-through arrangement, in order to utilize the supply fan heat to avoid a saturated supply airstream.

#### **10-7.1.1 Operating Room Air Systems.**

The room air supply system for Operating Rooms (C-Section, Cystoscopic, Cardiothoracic, Integrated, Hybrid, Neurology, Orthopedic, and General) must be a ceiling supply type, located over the operating table or treatment area, using non-aspirating "low velocity" 25–35 feet per minute diffusers that isolate the air over the



operating or treatment area. Extend the area of the primary supply diffuser array a minimum of 12 inches beyond the footprint of the surgical table on each side. Use no more than 30 percent of the primary supply diffuser array area for non-diffuser uses such as lights, gas columns, etc. Room exhaust and return provisions must consist of a minimum of two exhaust or return registers, located at diagonally opposing corners of the room, mounted with bottoms of registers between 6 inches and 9 inches above finished floor. In addition to the required low return or exhaust registers, return or exhaust may be accommodated using registers placed high on the walls.

### **10-7.1.2 Continuity of Service.**

The design for the HVAC systems serving Critical Care Spaces must include:

- a. The AHUs serving OR suites must be separate, independent units serving only the respective Surgical or Obstetrical Department or portions thereof, to enhance the reliability of these systems and minimize demand on the EES. However, if justified from a cost or functional standpoint, and where authorized by the Design and Construction Agent and the Using Agency, the AHU(s) serving each suite may also provide service to other Patient Care or support areas outside the respective Surgical or Obstetrical Department. A maximum of four ORs should be served by any single AHU. Where a Surgical or Obstetrical Department has four or fewer ORs, these should be served by at least two separate air handling systems, to enhance reliability.
- b. HVAC equipment, including controls, that serve Critical Care Spaces (including ventilation and pressure controls for isolation/protective environment bedrooms) must be connected to the EES. This must include a sufficient number of chillers and boilers, with necessary supporting equipment, to meet critical design loads. Boilers must have dual-fuel burners that are not solely dependent on one source of fuel for ignition.
- c. Designs must include features to minimize HVAC service interruptions to Critical Care Spaces, without the provision of redundant AHUs or distribution systems. Provisions must be such that service interruption to any Critical Care Space, as a result of failure of an AHU component or its supporting electrical or controls systems, must be minimized. Such features may include the provision of multiple, isolatable, heating and cooling coils; spare stock of replacement motors, drive belts, and bearings in the immediate vicinity of the equipment room; multi-fan units; or other measures providing for continuity or expeditious restoration of service.
- d. AHUs, with associated controls, that serve Critical Care Spaces and patient bedrooms must be connected to the EES.

### **10-7.2 Sensitive Equipment Areas.**

These are spaces or areas in which equipment or processes require special environmental control, including continuous (24 hours per day, year-round) air conditioning and individual room temperature or humidity control. Examples include Telecommunications Rooms and closets, data storage equipment spaces, Data Centers, spaces housing computer equipment supporting imaging and special treatment systems. For those spaces which are critical to continued facility operations, backup or redundant features must be provided to ensure continuity of air conditioning in the event of primary air conditioning equipment failure or when the primary system includes night-setback or economizer features. This may also include the requirement for connection of air conditioning equipment to the EES. Where feasible, the main building systems must be utilized for primary cooling/outdoor air and a redundant system utilized for back-up cooling.

### **10-7.3 Patient Bedrooms.**

Normal-care patient bedrooms may be served by dual duct, VAV, or single duct reheat systems. All systems utilized must maintain minimum ventilation quantities under all conditions of operation. Perimeter heating systems may be considered in conjunction with these air systems.

Isolation bedrooms must be served by airflow systems that maintain a constant differential between supply and exhaust airflow rates to maintain the required relative pressurization of the space to the adjacent spaces and corridor. Refer to more detailed design guidance and requirements for isolation bedrooms under 10-17, Isolation and Protective Environment Room Design. Pressurization control equipment serving protective environment and airborne infection isolation bedrooms must be connected to the electrical EES.

### **10-7.4 Temporary and Deployable Facilities.**

When considerations of logistics, equipment availability, limited O&M capability, or expediency dictate, deployable facilities may be served by unitary equipment meeting—to the extent practicable—the ventilation, filtration, and environmental conditions established in Appendix B, Architectural and Engineering Design Requirements. Temporary facilities may utilize unitary, all-water, or fan-powered VAV systems when authorized by the Design and Construction Agent and Using Agency.

### **10-7.5 Rooms with Critical Pressurization Requirements.**

10-7.5.1 All spaces in Appendix B, Architectural and Engineering Design Requirements, with air balance requirements of “++” or “- -” (to include associated anterooms and toilet rooms) must be designed and constructed with the volume differentials and room construction integrity to maintain a differential pressure of 0.02 inch water column between the subjected room and adjacent space, which must be demonstrated during commissioning. The volume differentials noted in Appendix B are a baseline and may need to be adjusted in order to achieve the required pressure

differential. Designer must evaluate the room size, fixed openings (e.g. door undercuts) and anticipated construction integrity in establishing the design volume differentials. The Designer must also consider the need to increase the room differential pressure to provide sufficient margin above the alarm value of 0.01 inches water column to minimize false alarms and ensure the integrity of the reading.

10-7.5.2 In order to prove the integrity of the air barrier, a leak-test of the room must be performed. Tests must be conducted with the room under positive pressurization, regardless of whether the end-state requirement is negative or positive. Provide temporary positive pressure high enough to ensure a valid test, approximately 0.05 inch water column. With the room under pressure, the test must consist of moving a smoke pencil at a rate of not more than 1 inch per second along all construction seams and interfaces, to include floor and structural ceiling partition interfaces, outlet boxes, and all partition penetrations by piping, conduit, cable, or other equipment. The visible passage of smoke at any point must be considered a failure, requiring resealing prior to repetition of the test. This test must be witnessed by the Government and commissioning team.

10-7.5.3 Rooms must be provided with a pressure indicating instrument or gauge, located on the outside wall near the door, that must visibly indicate that not less than a 0.01 inch differential pressure (negative or positive according to room type) is maintained under static (door closed) conditions, and that must alarm if the pressure is not maintained for a period exceeding 30 seconds. In addition, the pressure differential and alarms must be monitored by the building control system. If the alarm can be disabled or silenced locally, the building control system must monitor whether the alarm has been disabled or silenced.

## **10-8 GENERAL DESIGN CONSIDERATIONS.**

### **10-8.1 Plant Sizing and Optimization.**

For all facilities justifying a degree of redundancy in the capacity of primary energy plants, the precise number, capacity, and configuration of primary heat exchangers and pumps must be determined in accordance with the requirements noted here.

#### **10-8.1.1 Facilities with Critical Environments.**

These facilities include all Military Medical Facilities with inpatient functions, Ambulatory Healthcare Centers with operating rooms, and for selected Research and Vivarium facilities in which loss in ability to condition the facility would result in loss of critical research or animals at prohibitive cost to the Government. The plant must be sized and configured such that:

- a. For inpatient Military Medical Facilities, with one major heat exchanger or pump out of service, the remaining plant equipment is sufficient to serve all critical loads, including patient bedrooms and labor rooms, plus one-half of all remaining loads within the facility.

- b. For Ambulatory Healthcare Centers with operating rooms, with one major heat exchanger or pump out of service, the remaining plant equipment is sufficient to serve all critical loads to include surgery, surgical delivery, surgical prep, surgical recovery, decontamination, and sterile preparation and storage, plus one-half of clinical area loads.
- c. For Research and Vivarium facilities, with one major heat exchanger or pump out of service, remaining capacity must be sufficient to serve the critical environmental loads, plus all support spaces, such as computer records, critical to the continued operation of the facility. This must not include routine office, conference, classroom, or administrative areas.
- d. For all facilities with critical environmental requirements, with one major heat exchanger or pump out of service for an extended period (one day or more) of maintenance, during the “off” season for such service, the remaining plant equipment must be sufficient to meet the entire facility’s maximum load.
- e. For all such facilities, plant optimization must in addition be based on LCCA of the most life-cycle economical number, capacity, and configuration of prime heat exchangers and pumps.

#### **10-8.1.2 Energy Plants for Other Facilities.**

When energy plants consisting of multiple primary heat exchangers are justified, on a project by project basis, for large Outpatient Clinics or Ambulatory Healthcare Centers without operating rooms, the plant must be designed on the basis of LCCA of the most life-cycle economical number, capacity, and configuration of prime heat exchangers and pumps.

#### **10-8.2 Contaminant Removal.**

HVAC systems must be designed to remove or reduce to acceptable levels volatile chemical and airborne microbiological contaminants within the facility. Systems must be designed to remove excessive moisture in facility spaces and to control moisture and dust accumulation in AHUs, distribution elements, and chases, to avoid conditions permitting the growth of pathogenic, allergenic, or otherwise objectionable microorganisms.

#### **10-8.3 Interdepartmental Air System Restriction.**

In general, individual facility departments should be served by dedicated air handling systems in order to increase system flexibility, energy conservation, facilitate comfort control, and reduce demands upon the EES. When laboratories, pharmacies, Emergency Department, or other facility departments are required to operate during normally-unoccupied areas of the balance of the facility, these must be served by dedicated air handling and distribution systems.

#### **10-8.4 Air Filtration.**

Individual space air filtration must be provided as indicated in Appendix B Architectural and Engineering Design Requirements. MERV 8 “roughing” filters must be provided upstream of all coils, velocity sensing devices, or other devices requiring protection from dust accumulation. “Roll filters,” cleanable media, or other filtration systems requiring more intensive maintenance are not acceptable. Designers must carefully consider the location of filters relative to humidifiers to minimize the possibility of wetting the filter media. High capacity cartridge-type filters, in lieu of bag type filters, must be provided for units serving Critical Care Spaces due to the propensity for the latter to release particles during air handler startup and shutdown.

#### **10-8.5 Balancing Ports and Features.**

Necessary controls, instrumentation, and balancing ports and devices must be provided to establish and maintain the required space temperature, relative humidity (RH), and air changes rate, and to facilitate balancing procedures for all systems.

#### **10-8.6 Additions and Alterations to Existing Facilities.**

##### **10-8.6.1 Site Investigation.**

Designers must conduct thorough investigations of existing facilities to be upgraded or modified, to become knowledgeable with facility conditions as established by the terms of their design contracts. This includes the need to inspect concealed spaces, e.g., above-ceiling plenums, equipment rooms, and chases, to permit evaluation and accurate depiction of as-built conditions that can affect new work. Design and Construction Agents must ensure that this requirement is met; it is advantageous that the expected scope of the site investigation be discussed in detail with the designer during project pre-negotiation and “kickoff” meetings. Generally, designers should be required to directly inspect all equipment rooms and all above-ceiling areas in such a number of locations as to reasonably establish the existing conditions. In facilities with “hard” ceilings, this may require the creation of a suitable number of inspection openings: Design and Construction Agents must define in the Project Design Instructions the responsibility for making and repairing such openings. Structural and architectural building elements, as well as existing equipment, that restrict equipment distribution space should be directly verified to the extent reasonably practicable. The design team must recognize the economic advantages of a detailed designer site investigation: if the designers do not verify conditions, the construction contractor must do so, normally at a cost premium reflected in higher bidding costs (unknown conditions) and change orders (changed conditions).

##### **10-8.6.2 Modifications to Existing Systems.**

Too often in the past, addition and alteration project design documents have failed to provide the detailed engineering guidance required to sustain operation of systems serving occupied areas, leaving this engineering responsibility in the hands of QA personnel or construction contractors. The results have included loss of critical

services, inadequate system performance, project completion delays, and costly change orders. Therefore, it is hereby emphasized that it is the responsibility of the project designer to carry out all aspects of the design that can reasonably be accomplished during the design phase. Modifications to existing equipment and systems, including temporary connections, changes to system performance, or measures necessary to sustain service, must be shown and described in detail in project design documents. Designers must evaluate the impact on existing systems of extensions of service that increase system demand. The locations of new connections must clearly be shown or described, or both. The designer must determine, and document for the Design and Construction Agent's information, any project work that must necessitate a reduction or interruption of any service to an existing, occupied area. Consider and document Interim Life Safety Measures (ILSM) for use by the facility in accordance with Chapter 14 Fire Protection and Life Safety.

#### **10-8.6.3 Protection of Patients from Construction Contaminants.**

For additions or alterations to existing hospitals, measures must be provided to minimize contamination of existing hospital areas during the construction period and the associated HVAC systems serving them. Measures to reduce the potential of contamination and nosocomial infections include but are not limited to: negative isolation of construction areas, construction of effective dust barriers (including double-barrier air locks at entrances and exits) separating construction from occupied areas, protection of air distribution systems serving occupied areas, and disinfection of any reused ductwork. Designers must consult with the facility's infection control representative during the design process to ensure thorough coordination of design features that may affect patient welfare. See also the Sheet Metal and Air Conditioning National Contractors Association (SMACNA) *IAQ Guideline for Occupied Buildings under Construction*.

#### **10-8.6.4 Construction Phasing Plan.**

Reference Appendix C Design Submittals and Documentation.

#### **10-8.6.5 Commissioning Considerations.**

Reference Chapter 19 Commissioning and Appendix C Design Submittals and Documentation.

#### **10-8.7 Cooling and Heating Load Calculations.**

##### **10-8.7.1 Heating Load Calculation.**

Calculations used for determination of primary and airside (including reheat) heating equipment must not include credit for internal load sources, including lighting, people, and equipment. These loads are typically not present, or are much reduced, at night and on weekends. Heat calculations should also take into consideration morning warm-up loads when night setback temperatures are utilized in non-ward areas.

### **10-8.7.2 Equipment Heat Generation.**

In many spaces within Military Medical Facilities, the primary component of cooling loads must be equipment heat generation. It is therefore necessary for accurate load determination that the HVAC designer coordinate on a project-by-project basis with the medical or research equipment designer, and with the individual Using Agency, to identify all individual equipment items and the corresponding load contributions. To estimate equipment usage duration and frequency, designers must gather information from the Using Agency, or if unavailable from that source the manufacturer, personal experience, or other sources. In performing load calculations, designers must consider the as-designed equipment provisions of each unique space. "Rules of thumb" loading assumptions are not acceptable for final design calculations.

### **10-8.7.3 Lighting Loads.**

Lighting loads present a significant component of Military Medical Facility cooling loads and, as such, require consideration of the as-designed lighting fixture numbers and characteristics of each space. "Rules of thumb" lighting load assumptions are not acceptable as the basis for final design load calculations.

### **10-8.7.4 Envelope Components.**

Minimum insulation values for building envelope components must be in compliance with UFC 1-200-02. U-value calculations must take into consideration the "fin effect" of metallic elements of wall and roof construction, as, for example, the effect of steel studs in walls that may as much as halve insulating effectiveness of batt insulation.

## **10-8.8 Piping Systems.**

### **10-8.8.1 Pipe Routing.**

Piping distribution systems should be routed above corridors whenever practicable, to minimize leaks, maintenance intrusion, and noise in occupied areas of the Military Medical Facility. Pipes must not be routed through Telecommunications Rooms and Electrical Rooms unless dedicated to serving that room.

### **10-8.8.2 Thermal Expansion.**

Designers are responsible for designing all aspects of piping systems necessary for the control of thermal expansion, and for showing the necessary control features on design drawings. This includes showing and dimensioning, as applicable, the approximate locations of guides, anchors, expansion ells and offsets, and flexible couplings, as well as any other piping features that may affect expansions forces in the piping. The intent of this requirement is to ensure that this critical aspect of piping design is accomplished by the qualified mechanical engineer selected for the project design, and not by a construction contractor of unknown engineering ability or qualification. In the case of direct-burial, i.e., pipe within a pipe, underground heat distribution systems, engineering of the expansion compensation features by the system manufacturer may be preferred or necessary. Designers must design piping systems such that piping expansion forces

are isolated from equipment. Design and Construction Agents must ensure contractor's shop-drawing layout drawings of piping systems subject to thermal expansion are reviewed by the designer or by an equally qualified engineer representative of the Government.

### **10-8.8.3 Steam and Condensate Piping.**

Steam mains above 15 psig must not be distributed in above-ceiling areas of spaces normally occupied by patients or public within a Military Medical Facility, to include corridors. Designers must show the required direction and degree of line slope on drawings, and must provide and show the locations and details of drip traps and other drainage features. Piping for clean steam and associated condensate return must be stainless steel.

### **10-8.9 Insulation for Mechanical Systems.**

Insulation thicknesses and thermal characteristics must be not less than cited per ASHRAE 90.1. Insulation with higher "U" values must be provided when shown to be life-cycle cost effective. Insulation materials must be as permitted by United Facilities Guide Specifications (UFGS); it is important to note that under no circumstances will mineral wool or fiberglass insulation be permitted on new chilled water systems or other systems handling fluids at a temperature below 60 degrees F.

## **10-9 HVAC SYSTEM CONTROLS.**

### **10-9.1 Energy Conservation.**

All designs must comply with UFC 1-200-02. Additional information on energy conservation design is referenced at Chapter 4 Sustainable Design Principles.

### **10-9.2 Temperature Control.**

Individual room temperature controls must be provided for all Critical Care Spaces, sensitive equipment spaces, patient bedrooms, labor rooms, and laboratories, to closely maintain the room conditions provided in Appendix B Architectural and Engineering Design Requirements. Zoned temperature control must generally be utilized for other spaces within the facility. Only rooms with similar exposures and load profiles must be served by a single zone, with a maximum of six spaces per zone. All conference rooms, classrooms, and other rooms with unique exposures or load profiles must be served by a single zone. All variable volume terminal controllers serving normally occupied spaces must be provided with a means of reheat, if a separate means of room heating (such as perimeter heating) is unavailable.

Wound Intensive Care (Burn Care Rooms) must be provided with room temperature controls to maintain temperatures up to 100 degrees F with humidity control as indicated in 10-9.4, Humidity Control.



### **10-9.3 Control Precision.**

Temperature controllers must maintain space temperature within +/-2 degrees F of active set-point, as provided for the individual spaces in Appendix B Architectural and Engineering Design Requirements. The summer and winter design set-points normally differ. For some spaces, a temperature range is given as the summer or winter interior design condition in lieu of a specific temperature set-point. The HVAC system for such spaces must be designed with the capability, under design conditions, to maintain any selected temperature within that range.

### **10-9.4 Humidity Control.**

Humidity controls must be provided as necessary to meet the requirements given for individual spaces in Appendix B Architectural and Engineering Design Requirements. Under all circumstances, central AHU humidifiers must be provided for units serving Critical Care Spaces, including patient bedrooms. If necessary to maintain the RH within the allowable range, humidity controls must be provided on a room basis for these Critical Care Spaces:

- a. ORs
- b. Cystoscopy Rooms

Humidity controls for Wound Intensive Care (Burn Care Rooms) must be provided on a room basis in order to maintain 35–50 percent RH +/-5 percent at room temperatures up to 100 degrees F. Humidity controls for all other spaces may be provided on a zone or system basis as determined to be sufficient to maintain the required conditions.

#### **10-9.4.1 AHU Humidifying Equipment.**

Air handling system humidification must be achieved utilizing direct steam injection, with a steam source in accordance with 10-10.1, Humidification Steam Source, utilizing humidifiers of the rapid absorption, steam jacketed distribution type designed to deliver dry steam and accomplish complete re-evaporation within 3 feet of the discharge manifold, under the air velocity and temperature conditions designed. No equipment must be located in the AHU casing within the downstream re-evaporation distance, and the inner casing liner within this section must be constructed of stainless steel. Designers are responsible to designate the location of steam injectors relative to ductwork and AHU components, and so design them as to minimize concerns with moisture collection in or on the downstream elements. To minimize the risk of introducing condensation into the air stream, design humidifier control sequences such that the supply air relative humidity will not exceed 85% under winter heating load conditions. Provide safeties including but not limited to a dedicated air flow switch and duct high-humidity limit switch.

#### **10-9.4.2 Trim Humidification for Critical Care Spaces.**

Humidification must be achieved utilizing direct steam injection, with a steam source in accordance with paragraph 10-10.1 Humidification Steam Source. Humidifier must be

separated a minimum 15 feet upstream from high-efficiency final filtration, or any other duct equipment, elbow, or takeoff; when this separation cannot practicably be achieved, rapid-absorption-type humidifiers must be provided with design as indicated in paragraph 10-9.4.1 AHU Humidifying Equipment. Ductwork within the downstream re-evaporation distance must be constructed of stainless steel with provisions for drainage of condensate.

#### **10-9.5 Direct Digital Controls (DDC).**

The DDC System must be a complete system suitable for the control of the HVAC system and other building level systems as specified. Reference UFC 4-010-06 for cybersecurity requirements. When a Using Agency determines that communication between a facility's DDC system and a remote Utility Monitoring and Control System (UMCS) is required, the design must ensure that the DDC system is seamlessly compatible with the UMCS system.

No remote UMCS system, i.e., not located in the Military Medical Facility or its associated energy plant, will be permitted to exercise control over any hospital HVAC system equipment providing service to Critical Care Spaces. Remote UMCS systems may be provided with monitoring, alarm, and reporting capabilities as necessary to facilitate maintenance activities.

#### **10-9.6 Air Handling Equipment Control.**

##### **10-9.6.1 Building Pressure Control.**

All systems must maintain the building at relative positive pressure to the outside environment, with the exception of those spaces on perimeter walls required to maintain a negative pressure relative to contiguous spaces. For facilities in humid climates, and for all facilities of three stories or more in height, automatic controls must be provided to actively monitor and control building pressurization via pressure monitoring at strategic locations on each level, and manipulation of outside air, exhaust volume flow rates, or both. All systems that modulate outside air, including all VAV air handling systems, must include accurate airflow measurement arrays located in accordance with manufacturer's recommendations as part of their control system. Positive building pressure must be maintained at all times (24/7) for all facilities located in humid climates.

##### **10-9.6.2 VAV AHU Controls.**

All VAV systems must be provided with supply and return fans. Airside economizer must be provided where economically life-cycle cost effective. Fan speeds must be modulated by means of variable-frequency drivers (VFDs). For units utilizing multiple fans (i.e. fan arrays), provide each fan with a separate VFD. Supply fans must modulate based upon maintaining a fixed static pressure at a location remotely located in the ductwork sufficient to ensure operation of all VAV terminal devices. Supply, return, and outside airflow rates must be measured by the DDC control system, and the

return fan must modulate to maintain a fixed differential airflow below that of the supply fan. A high supply duct static sensor and shutdown capability must be provided.

### **10-9.6.3 Variable Exhaust Controls.**

HVAC controls for laboratories, treatment rooms with coughing booths, autopsy procedure rooms, and other rooms having equipment requiring variable or intermittent exhaust requirements, must be provided that maintain the required room relative pressurization and room conditions for all modes of operation of the equipment, e.g., on or off, minimal to maximum sash height, according to the user's intended operation. Variable flow controls must be provided for the general exhaust of such rooms as well as for the equipment, to allow measurement and tracking of supply to exhaust flow differential by the DDC system.

## **10-10 STEAM SYSTEMS.**

### **10-10.1 Humidification Steam Source.**

Steam generated by heating system boilers (or any other steam) containing amines oxygen scavengers, or other treatment chemicals must not be used for space humidification in any air handling unit or air distribution system serving Critical Care spaces. Separate steam generators for humidification must be provided for these systems and must be constructed throughout of stainless steel (317 or better).

In systems serving non-critical care spaces, if authorized by the Design and Construction Agent, central steam systems utilizing chemically treated steam generated under the following conditions may be utilized:

10-10.1.1 Water entering humidifiers or primary steam generators must originate from one of the following sources.

- Potable water
- RO water
- DI water

10-10.1.2 With the exception of the three specific amines listed below, boiler treatment chemicals as regulated by 21 CFR 173.310 may be utilized. Chemicals and minerals must not be present in the steam in concentrations that are known to be hazardous to health or that might contribute to an indoor air quality problem. All chemical dosing must be accomplished with automated equipment. The specific chemicals listed below may be present in steam, but they must not exceed the following concentrations in the steam.

- Cyclohexylamine (CHA) : 10 ppm
- Diethylaminoethanol (DEAE) : 5 ppm
- Morpholine : 10 ppm

## **10-10.2 Sterilizer Steam Source.**

Steam generated by boilers located in an onsite (hospital-dedicated) boiler plant may be utilized for sterilization steam subject to approval by the Using Agency. As hospital authorities cannot normally exercise a reasonable degree of supervision or control over treatment chemicals utilized in base-wide or district systems, steam from these sources may not be utilized for direct sterilization. Unlike humidification steam, which is injected directly into the air supply, little sterilizer steam must escape into a facility's general environment. Under a reasonably responsible boiler treatment program, any steam that does escape must not result in dangerously high levels, e.g., Occupational Safety and Health Administration (OSHA) Recommended Exposure Limits (RELs), of treatment chemicals in the environment.

## **10-11 AIR HANDLING AND DISTRIBUTION.**

### **10-11.1 AHU Requirements.**

AHUs are to be double-wall, internally-insulated, readily maintainable units suitable for utilization in Military Medical Facilities. Draw-through units are normally preferred to utilize fan heat to increase the DB air temperature above the saturation point and minimize the possibility of wetting downstream filters, attenuators, or other components. If draw-through units are not provided, an alternative, energy-efficient heating source must be provided to ensure that supply air delivered from the AHU is at least 2 degrees F above saturation temperature. Provide for minimum 18-inch wide access doors immediately upstream and downstream of all coils, to facilitate coil cleaning and proper installation of the unit freeze stat. When unit heating or cooling capacity are provided—in part or total—by heat reclaim devices, AHUs must be provided with conventional preheat and cooling coils sized for the total system load, to ensure continued service when heat reclaim equipment is out of service.

### **10-11.2 System Shutdown Capability.**

To the extent practical and cost effective, non-critical, non-bedroom area HVAC systems must be designed to permit shutdown (night setback and setup, outside air shutdown) of individual areas or departments not in operation on a 24-hour basis. In any facilities in which any spaces are exhausted during non-occupied hours, the HVAC design must provide for conditioned make-up air to prevent a negative pressure within the facility relative to the outside, and the admittance of unconditioned, unfiltered infiltration air. For facilities not located in humid climates and where no spaces are exhausted during non-occupied hours, negative building pressure may be prevented by shutdown of the HVAC system and isolation from the outside by closing outside, relief, and exhaust air dampers.

Air distribution systems must comply with the requirements in UFC 4-010-01 except as modified herein. Due to the nature of operations in military medical facilities, completely shutting down HVAC in areas that would risk the health of patients, visitors, and staff is not a decision to be made lightly, and inadvertent activation of the HVAC shutdown must be minimized. The quantity and locations for Emergency Air Distribution Shutoff

Switches must be coordinated with the Design and Construction Agent. In any case a minimum of one (1) shutdown switch must be provided. All shutdown switches must be protected from accidental activation by a flip up cover or other double action device. Emergency Air Distribution Shutoff switches for systems serving any critical care spaces, spaces with critical pressurization requirements ("++" or "--" in Appendix B), or other spaces where HVAC shutdown would pose an immediate danger, must be by keyed switches. These switches must be provided with the following signage "Danger! Critical Care HVAC Shutdown, Exposure Hazard". Signage must be red background with white letters and be placed above any cover for each individual button. Keyed switches permit responsible personnel in leadership to weigh the risk associated with intentionally degrading a life preserving internal environment to protect against the introduction (or distribution) of an airborne hazard into the facility. Switches for systems serving only non-critical care spaces must be provided with the following signage "Emergency Use Only! Mechanical HVAC System Shutdown". Signage must be red background with white letters and be placed above any cover for each individual button.

### **10-11.3 Outdoor Air Intakes.**

Outdoor air intakes must be located as far as practical, but not less than 30 feet, from exhaust outlets of ventilation systems, cooling towers, combustion equipment stacks, MV systems exhaust, plumbing vent stacks, emergency generator exhaust, or from areas that may collect vehicular exhaust and other noxious fumes. Locate the bottom of air intakes serving central systems as high as practical but not less than the distance above ground level required by UFC 4-010-01, or if installed above the roof, at least 3 feet above roof level. Outdoor air must not be drawn from equipment rooms. Designers must utilize judgment in the location of contaminant exhausts, and not simply apply the "9M rule" without further consideration of wind direction and velocity, building geometry, and characteristics of the contaminant stream. Appropriate consideration must be given to prevailing wind direction and the season, e.g., summer or winter, as applicable; however designers are cautioned not to rely on prevailing wind direction(s) as a primary factor in the avoidance of intake contamination. In particular, use extreme caution in locating outside air intakes in proximity to parking areas, ambulance garages, loading docks, exhaust air outlets, and equipment stacks. Where appropriate, the Design and Construction Agent will provide individual Project Design Instructions for special computational fluid dynamics (CFD) or wind tunnel modeling to provide greater assurance of the correct location of outside air intakes.

### **10-11.4 Noise Control.**

Noise criteria for individual rooms and spaces in the facility are provided in Appendix B Architectural and Engineering Design Requirements.

#### **10-11.4.1 Room Breakout.**

The HVAC designer must coordinate with the architectural designer to control equipment noise passing from mechanical rooms into adjacent spaces through the surrounding walls or partitions.

#### **10-11.4.2 Crosstalk.**

The compromising of patient privacy by transmission of audible speech from one room to another via ductwork is of great concern in Military Medical Facilities, and must be addressed by HVAC designers. Examination rooms, physician's offices, and toilets require the designer's particular attention. Ductwork connecting adjacent rooms must have the necessary attenuating characteristics to eliminate audible speech transmission. Typically, this is addressed by the provision of well-separated "takeoffs" or several duct elbows in the intervening ductwork, or both.

#### **10-11.4.3 Air Fixtures.**

Air distribution supply, return, and exhaust fixtures, e.g., diffusers or grills, must be sized to provide air inlet and outlet velocities consistent with room noise criteria level requirements as provided in Appendix B Architectural and Engineering Design Requirements. Designers must be aware that diffuser manufacturer's published noise characteristics are based upon idealized inlet conditions. Use of crinkled flex duct, abrupt branch duct connections, elbows located immediately at the diffuser collar, and similar poor connections may result in unacceptable noise levels. Spin-in or other 90-degree duct drop connections to diffusers must be equipped with equalizing grids as necessary to ensure uniform air distribution at the diffuser inlets.

#### **10-11.4.4 Air Velocity.**

Designers must limit air velocities in ductwork, air transfer grills, or door undercuts to values consistent with ASHRAE recommendations to control noise generation.

#### **10-11.4.5 VAV/Constant Air Volume (CAV) Terminal Units.**

VAV terminal units and constant velocity controllers are a frequent source of noise generation in air distribution systems. Designers must specify or schedule units with minimum inlet sizes for incremental ranges of flow, and must indicate maximum sound power output for each unit, at the maximum inlet static pressure that the designer anticipates the unit must be exposed to. If integral sound attenuating devices are required, these must be indicated for the respective terminal unit(s) in specifications or drawing schedules.

#### **10-11.4.6 Exterior Noise Sources.**

Designers must evaluate the sound characteristics of exterior equipment provided as part of the project design (such as cooling towers and emergency generators) to ensure that such sources do not result in interior noise levels exceeding limitations provided in Appendix B Architectural and Engineering Design Requirements.

#### **10-11.5 Duct Design.**

Design duct systems in accordance with the *ASHRAE Handbook* series, ACGIH Industrial Ventilation: A Manual of Recommended Practice, NFPA 96, and SMACNA HVAC Systems Duct Design. Maximum velocity in ductwork mains must not exceed

1,800 feet per minute over occupied spaces, or a maximum of 2,500 feet per minute elsewhere, and velocities in branch ducts and takeoffs must not exceed recommended levels in those references. Ductwork plans must indicate the static pressure class required for sealing and reinforcement for all types of duct. Access panels must be provided as necessary for access to fire dampers, smoke dampers, humidifying equipment, control equipment to include reheat coils, and other equipment requiring periodic inspection or maintenance. All supply air, with the exception of air transferred between spaces for the purpose of pressurization, and flexible terminal equipment connections must be provided in sheet metal ductwork.

#### **10-11.5.1 Non-Corrosive Ductwork Material.**

Ductwork installed downstream of high efficiency final filters (Merv 14 or greater, see Appendix B Architectural and Engineering Design Requirements) serving Critical Care Spaces must be of stainless steel or aluminum, including all accessories such as dampers, fasteners, and turning vanes. This provision does not apply for ductwork downstream of high-efficiency filters when these are located at the AHUs (filters noted in the "intermediate" column in Appendix B Architectural and Engineering Design Requirements). Stainless steel ductwork downstream from trim humidifiers must extend for the manufacturer's cataloged re-evaporation distance. Exhaust ducts for glass washers, dishwashers, and cart washers must be non-corrosive and must have soldered or welded joints and must be pitched to drain.

#### **10-11.5.2 Return Air Plenums.**

Provide fully ducted return air systems for all Military Medical Facilities, except stand-alone administrative buildings or deployable facilities. Temporary facilities may be considered for plenum returns where authorized by the Design and Construction Agent and the Using Agency. Corridors must not be used as return air plenums in any portions of a facility. Exceptions allowing transfer air for toilets and janitor's closets, as provided in NFPA 90A and 101, will be permitted.

#### **10-11.5.3 Duct lining.**

The utilization of duct lining materials is prohibited in all Military Medical Facilities. These materials may harbor dust and moisture, providing an ideal environment for the propagation of pathogenic or noxious microorganisms. Factory fabricated sound attenuators, packed type, constructed with a perforated inner steel liner and Mylar<sup>®</sup> or foil underlay separating the packing from the airstream, must be provided to attenuate noise. Such attenuators must comply with ASTM C1071 and UL 181.

#### **10-11.5.4 Balancing Provisions.**

Duct branches serving each individual space must be provided with a manual balancing damper, accessible above the ceiling, located as remote from the space supply or return fixture, e.g., diffuser or register, as practicable. The balancing damper provided as part of air diffusers is not to be used for system balancing. Duct systems which are fully welded due to containment requirements (e.g. Biosafety laboratories,

compounding rooms etc.) must be provided with permanent taps to facilitate pitot-traverse airflow measurement at main duct branches. These permanent taps must consist of welded nipples of the same material as the ductwork, with threaded caps, gasketed with material suitable for the materials in the airstream. Similar permanent pitot-traverse taps must be provided in the exhaust ducts serving Neat and Dilute chemical agent laboratories, and in kitchen grease hood exhaust. For the latter, tap nipples must extend to an accessible location outside of the fire resistant duct enclosure material.

#### **10-11.5.5 Telecommunication Rooms.**

Ducts must not be routed through Telecommunications Rooms in compliance with TIA-569-A.

#### **10-11.6 Cleanliness of Air Handling and Distribution Equipment.**

During project construction, all AHU and distribution equipment (including all ductwork and fittings exposed to the air stream) should be protected from contamination by dust and debris. This must typically involve covering or sealing the equipment until installation, and keeping open ends of ductwork covered until final connections to diffusers and registers are made. AHUs that are operated during building construction must be thoroughly cleaned and have new filters installed before beneficial occupancy of the facility. "Thoroughly cleaned" in this sense is defined as wiped clean of any visible dust or debris. Ductwork that has been improperly protected must also be thoroughly cleaned prior to installation or acceptance of the facility.

### **10-12 MAINTENANCE PROVISIONS.**

#### **10-12.1 General Personnel Access.**

Safe and practical means of personnel access must be provided to, and within, all areas of the facility where equipment is located, to adequately provide for O&M and replacement of the equipment. Access to equipment rooms from outside the facility should be provided where feasible. Within equipment rooms, provide clearance to all service points to mechanical equipment to allow adequate personnel access and working space in accordance with equipment manufacturer's recommendations; but as a minimum, maintain 2.5 feet at all service points and 5.5 feet of overhead clearance for O&M access-ways. Proper clearance must be provided such that personnel do not have to climb over equipment or crawl on hands and knees. When rooftop AHUs are provided on multiple story facilities, provide elevator access with direct means of transporting materials to the units via hydraulic handcart without damage to the roof.

Provide convenient stairway access when rooftop AHUs are provided on single story facilities; in addition, the HVAC designer must coordinate with the site designer to provide for a practical location for a mobile crane to approach within reasonable proximity of the AHU(s) for periodic transportation of maintenance or replacement parts and equipment.



### **10-12.2 Equipment Clearances.**

Minimum clearances between electrical and mechanical equipment must be as required by NFPA 70. Ensure that practical means are provided for the removal and replacement of the largest and heaviest equipment item(s) located in the facility. Provide adequate pull space for all coils, heat exchangers, chillers, boiler tubes, and filters. Sufficient space must be provided in above-ceiling areas to facilitate equipment installation and O&M. For building designs utilizing interstitial floor distribution zones, further guidance is provided at Appendix E Interstitial Building System.

### **10-12.3 Suspended and Mounted Mechanical Equipment.**

Where suspended and mounted equipment is installed, provide a minimum of 67 inches of clearance for headroom as required. In refrigeration equipment rooms, provide overhead clearances required by ASHRAE 15. For any work station or location requiring maintenance access that is not readily accessible from an 8-foot-high portable ladder, provide a fixed ladder or catwalk.

### **10-12.4 Air Distribution System Components.**

Design outdoor air intake plenums, AHU casings, and distribution ductwork to permit access for periodic cleaning or disinfection.

### **10-12.5 HVAC System Balancing Provisions.**

Adequate access must be provided to facilitate operation, adjustment, and testing at all HVAC balancing and measuring points and equipment, including automatic and manual damper operators, air terminal units, pilot tube ports, valves, and sensing devices.

Prior to Test and Balance (TAB) perform Duct Air Leakage Testing (DALT) in accordance with UFC 3-410-01 on all duct systems regardless of pressure class, to include all return, all exhaust, and all portions of supply upstream of terminal units.

## **10-13 VIBRATION CONTROL.**

All prime moving equipment must be isolated to prevent transmission of vibrations to the structure.

## **10-14 INTERDISCIPLINARY COORDINATION.**

### **10-14.1 Architectural Coordination for Rooms with Critical Pressurization Requirements.**

All spaces in Appendix B with air balance requirements of “++” or “- -” (and associated anterooms) must be designed and constructed with full height room partitions, extending from floor to structural ceiling, with all joints and penetrations sealed to prevent the passage of air.

## **10-14.2 Fire Protection Features.**

See also Chapter 14 Fire Protection and Life Safety.

### **10-14.2.1 Smoke and Fire Dampers.**

In support of defend-in-place evacuation, design HVAC service zones to coincide with smoke compartments whenever practicable. Ductwork penetrations of fire and smoke-rated walls should be minimized, to minimize the required number of smoke and fire dampers and complexity of controls. Coordinate with the architectural design to ensure that necessary access for inspection or service of these dampers is provided.

### **10-14.2.2 Ductwork.**

Air supply and exhaust systems must be of the mechanical ventilation type and must meet the requirements of NFPA 90A and 96. Grease-laden vapor exhaust ductwork must be in accordance with NFPA 96.

### **10-14.2.3 Smoke Management Operation.**

Comply with Chapter 14 Fire Protection and Life Safety.

### **10-14.2.4 Commissioning of Fire and HVAC Systems.**

Guide specifications typically do not contain provisions for the simultaneous testing of HVAC and fire protection systems, which can have complex, interwoven operational requirements in some facilities. For each project where applicable, designers must develop or modify specifications as needed to provide for testing of HVAC systems under fire alarm conditions, to permit verification not only of correct function, but of acceptable speed of response. In more complex systems involving smoke evacuation or compartmentalization and pressurization, or provisions of smoke/exhaust in support of defend-in-place evacuations, detailed testing protocols, system diagrams, or both, must be developed to clearly convey the required scope of the commissioning effort. (Reference Chapter 19 Commissioning.)

## **10-14.3 Essential Electrical Service.**

### **10-14.3.1 Capacity.**

The HVAC system equipment serving Critical Care Spaces must be connected to the EES to ensure service continuation in the event of normal power disruption, in accordance with the requirements of NFPA 99. Cooling, as well as heating, must be maintained to Critical Care Spaces in the event of normal power outage.

### **10-14.3.2 Commissioning.**

Service guide specifications do not adequately address testing requirements for HVAC and EES interoperability. HVAC systems connected to the EES must be shown to function as intended under conditions of normal power interruption. Testing of the EES

must be conducted in conjunction with any components of the HVAC system required for support. For example, thermostatically operated louvers may be required in emergency generator rooms for make-up air, generator radiator cooling may be a function of such HVAC components as pumps or cooling tower. Testing must verify the actual connection of HVAC equipment to the EES in accordance with the design following normal power outage, in the priority sequence established by the design. Designers must supplement or modify guide specifications to ensure that such verification testing is adequately detailed and described. (Reference Chapter 19 Commissioning.)

#### **10-14.4 Seismic Design Requirements.**

Refer to Chapter 8 Seismic for seismic provisions for the HVAC system equipment and components. Designers must be responsible for ensuring that seismic bracing of HVAC piping is coordinated by design with thermal expansion compensation features, to allow for the necessary pipe movement with temperature changes.

#### **10-14.5 Design Coordination.**

Designers are responsible to coordinate the HVAC with the electrical, communications, architectural, and structural aspects of the design to ensure that equipment can reasonably be installed by a contractor providing equipment, and following installation procedures, within the terms of his contract. For this reason, designers are instructed to base equipment room and distribution space designs upon spatial envelopes (including maintenance clearances) that must accommodate any of at least three manufacturers of major equipment. Routes of ductwork and piping must be carefully coordinated with other elements, considering required slope, insulation, bracing, reinforcement, slope, and maintenance access. This practice in no way infringes on or substitutes for the construction contractor's responsibility, to be defined in project specifications, to coordinate the installation work of all trades and to provide detailed shop drawings showing the proposed construction. Rather, it ensures that the contractor must be able to achieve his goal without the necessity of additional design work.

##### **10-14.5.1 Equipment Rooms.**

To ensure adequate coordination, designers must consider not only the HVAC equipment, but the work requirements of other trades. Ensure adequate clearance around AHUs to permit bolting the units together and securing them to their housekeeping pads, meanwhile providing space for the general contractor to install wall partitions. Consider the locations of plumbing and medical gas equipment. Ensure it must be possible for maintenance workers to access all controls, electrical panels, valves, and instrumentation. Be aware of NFPA 70 clearance and vertical dedicated space requirements for electrical equipment. Coordinate parameters such as ductwork and outside air plenums with the locations of lighting.

### **10-14.5.2 Above-Ceiling Plenums and Chases.**

Designers must anticipate the worst-case insulation, duct reinforcement, equipment support, slope, and fitting characteristics associated with ductwork and piping distribution systems, and be careful to coordinate the location of these systems with other equipment, including in particular cable trays and lighting fixtures with their vertical access and clearance space requirements. Ensure that access space is considered for damper operators, low-point steam drip assemblies, VAV terminal units, reheat coil controls and instrumentation, service valves, and access doors for ductwork for cleaning or damper inspection.

### **10-15 FUEL STORAGE REQUIREMENTS.**

Refer to Chapter 8 Seismic, Paragraph 8-3, for requirements for assessing the extent of onsite fuel storage for facilities in seismic threat regions. Additional fuel storage guidance for boiler plants must be obtained from the individual service criteria.

### **10-16 VENTILATION DESIGN.**

#### **10-16.1 Ventilation Air Changes.**

Provide the minimum air change rates for each space, for outside air and total air, required by Appendix B Architectural and Engineering Design Requirements. Total air changes as established by Appendix B must consist of the outside air changes, plus re-circulated airflow through a main AHU having the minimum filtration called out for that space in the appendix. For rooms with a positive pressurization requirement, calculate the total air changes based on the supply volume and for rooms with a negative pressurization requirement, calculate the total air changes based on the exhaust/return volume.

10-16.1.1 Whenever a room is occupied, the minimum air change rates must be provided.

10-16.1.2 The minimum outside air change ratio in Critical Care Spaces must be maintained at all times. Increase the minimum outside air calculated below as needed to ensure that the ratio is maintained for Critical Care Spaces.

10-16.1.3 Provide minimum outside air at the AHU equal to the corrected Outdoor Air Intake ( $V_{ot}$ ), per the following equation:

$$V_{ot} = V_{ou} / (1 + X - Z)$$

Where:

$V_{ou}$  = the sum of all individual space outside air requirements for spaces served by the AHU,

X = the ratio of  $V_{ou}$  to total ventilation air calculated to be required, and

Z = the largest ratio of outside air to ventilation air for any of the spaces served by the AHU.

### **10-16.2 General Exhaust Provisions.**

Exhaust systems must be provided for animal holding areas, autopsy and morgue spaces, laboratory fume hoods, radioisotope hoods, bacteriological cabinet, kitchens, laundry, toilets, isolation rooms, equipment rooms, and other areas as noted in Appendix B Architectural and Engineering Design Requirements, or as designated on an individual project basis. No duct system conveying potentially hazardous exhaust, e.g., ethylene oxide (ETO) sterilizers and lab hoods, must be connected with a general or toilet exhaust system. The duct system conveying isolation room exhaust must be dedicated to isolation rooms and their associated anterooms and toilet rooms, and not be connected with other exhaust systems. All exhaust discharge outlets must be located above the building roofline and located to prevent short-circuiting to air intakes or other building openings. Exhaust fans must be located at the end of the exhaust duct run (exhaust ducts to be under negative pressure).

### **10-16.3 Space Pressurization.**

The required pressurization of individual spaces, relative to adjacent spaces or corridors, is indicated in Appendix B Architectural and Engineering Design Requirements. Where a negative or positive pressurization are required for a given critical or patient bedroom space, that pressurization must be maintained by the HVAC system under all conditions of operation, including periods of reduced ventilation or night setback.

### **10-16.4 Laboratory Ventilation.**

Exit corridors must not be utilized to directly supply or exhaust air from the laboratory, although "transfer" of air to and from corridors may be utilized to establish required room pressurization. Negative pressurization of laboratories in relation to surrounding occupancies must be maintained under all conditions of HVAC system and fume hood operation.

#### **10-16.4.1 Exhaust Systems.**

Laboratory equipment utilized for personnel protection from hazardous chemical, microbiological, or radioactive airborne particles or gases must be provided with independent exhaust systems in accordance with NFPA 45. Exhausts from general chemical laboratory fume hoods located within a laboratory unit may be combined into central exhaust systems in accordance with guidance in NFPA 99 and NFPA 45. Exhausts from hoods handling perchloric acid or other strong oxidizing agents, materials, or agents requiring high-efficiency particulate air (HEPA) filtration, or exhausts which, when combined, chemically interact or change the explosion or ignition limits, may not be combined. Additional guidance for hood and exhaust design is contained in the *ASHRAE Handbook* series, the *Manual of Recommended Practices for Industrial Ventilation*, NFPA 45, ASHRAE 15, and ASHRAE 62.1. Exhaust duct

discharge height must be above the building recirculation cavity boundary. In all cases, exhaust discharge must have sufficient stack height, velocity, and distance from building openings, outside air intakes, or recirculating air currents, to preclude reentry into the building. Air velocity in exhaust ductwork must be sufficient to transport the contaminant vapors, fumes, dusts, or other particulate matter for which the fume hood(s) is designed. Refer to paragraph 10-11.5.4 for requirements for permanent pitot traverse ports in certain hazardous exhaust applications.

#### **10-16.4.2 Laboratory Fume Hoods, General.**

Fume hoods must be located in areas of minimal air turbulence, away from doors, windows, and traffic, to minimize disruption of required sash airflow. HVAC system and fume hood controls must be designed such that operation or shutdown of any fume hood in a given space must not disrupt the required room air balance or the required sash airflow at other hoods operating in the space. General-purpose laboratory fume hoods that control personnel exposure to chemicals and physical contaminants must have a minimum sash face velocity of 100 feet per minute. Fume hoods must be provided with audible and visual alarms to indicate inadequate sash airflow conditions.

#### **10-16.4.3 Radioactive Material and Radioisotope Hoods.**

Duct systems serving hoods for radioactive material must be constructed of acid-resistant-type stainless steel for their entire length. Ductwork must be flanged with neoprene gasketed joints to facilitate dismantlement for decontamination. Fume hood exhaust must remain in constant operation, and must be filtered with carbon or HEPA filters as required to meet Nuclear Regulatory Commission (NRC) requirements. The location of filters in the system must be chosen to best facilitate their safe removal, disposal, and replacement by maintenance personnel. All filters must be automatically monitored to provide indication that change-out is required. All hoods must comply with requirements of the NRC.

#### **10-16.4.4 Canopy Hoods for Prosthetic Dental Laboratories.**

Canopy hoods for Prosthetic Dental Laboratories, and exhaust ductwork extending for a distance 10 feet downstream from the hood connection, must be fabricated of material that is corrosion resistant to the caustic fumes emanating from boil-out tanks and casting activities conducted in the laboratory.

#### **10-16.4.5 Biological Safety Cabinets (BSCs).**

Class, type, and location of BSCs must be as directed by the Using Agency. Class II BSCs are provided with HEPA filtration of recirculated air or building exhaust, and are provided in such areas as Microbiology and Mycology. The required open door or sash face velocity for Class I and Class II Type A BSCs must be 75 feet per minute, and for Class II Types B1, B2, and B3, must be 100 feet per minute. For further information of biological safety hood class, type, application, and exhaust requirements, refer to the *ASHRAE Handbook* series, OSHA Part 1910, *Biosafety in Microbiological and Biomedical Laboratories*, and NSF/ANSI Standard 49.

#### **10-16.4.6 Perchloric Acid Hoods.**

Hoods for handling of perchloric acid and other strong oxidizing agents, and the associated exhaust ductwork, must be constructed of stainless steel. Internal water spray systems must be provided for hood and all ductwork to facilitate the periodic washdown. Joints must be welded and ground smooth, and all ductwork pitched back toward the hood to facilitate drainage. Welding must be in accordance with AWS D18.1 Hygienic Welding. More detailed guidance is provided by the ACGIH publication *Manual of Recommended Practices for Industrial Ventilation*.

#### **10-16.4.7 Containment Laboratories BSL-3 and BSL-4.**

These laboratories deal primarily with indigenous or exotic agents that may cause serious or potentially lethal disease as a result of exposure by inhalation. The HVAC design for these laboratories must ensure the continuous negative pressurization and exhaust of the space. The exhaust air from these spaces must not be recirculated to any other area of the building, but must be transported through dedicated exhaust ductwork to be directly discharged to the outside of the building. Design of BSL-3 and BSL-4 laboratory exhausts must comply with *Biosafety in Microbiological and Biomedical Laboratories*, DA PAM 385-69, and DoDM 6055.18-M.

#### **10-16.5 Exhaust Canopies.**

Exhaust canopies must be provided for equipment or appliances generating high heat or moisture (steam) loads, such as glassware washers, boil-out tanks, drying ovens, sterilizers, and stills. In some cases, specially designed canopy hoods may be necessary to control personnel exposure to hazardous chemical vapors. Canopy hood design must comply with the ACGIH data for "Canopy Hood" from the *Manual of Recommended Practices for Industrial Ventilation*.

#### **10-16.6 Laminar Flow Clean Benches.**

These horizontal flow hoods must be used in pharmacy for preparing intravenous fluids and similar laboratory processes. Clean benches recirculate room air and do not require exterior air supply or exhaust systems.

#### **10-16.7 Bench-Back Slot Hoods.**

Slot hoods are typically built into the wall behind laboratory benches to exhaust vapors, gases, and odors that are released with little energy or velocity. Typical applications are laboratories, brace shops, and other spaces in which volatile chemicals are routinely used. Design of these hoods must be in accordance with ACGIH guidelines, with a slot velocity of 2,000 feet per minute.

#### **10-16.8 Portable Bench-Top Hoods.**

Portable hoods with glass viewing panels and interior lighting may be used to control chemical contaminants of minor toxicity and odors. They must be attached to built-in exhaust outlets with flexible ducts. Each built-in exhaust system outlet must provide a

minimum of 160 cubic feet per minute or a face velocity of 75 feet per minute at the hood, whichever provides the maximum mass flow of air. The exhaust duct opening must be provided with a blast gate and sealing plug to stop airflow when the unit is not in service.

#### **10-16.9 Medical Equipment.**

Reference Chapter 16 Medical and Dental Equipment for special ventilation requirements of medical equipment.

#### **10-16.10 Kitchen Hoods.**

Equip all hoods over cooking service equipment with fire extinguishment systems, automatic washdown, listed grease extractors, and heat-actuated fan controls. Cleanout openings and required fire protective enclosures and separations must be provided in horizontal exhaust duct systems serving these hoods and grease exhaust ducts in accordance with NFPA 96.

#### **10-16.11 Pharmaceutical Admixture Rooms.**

Pharmacy admixture rooms must be in compliance with USP 797 and/or USP 800, Pharmacists' Pharmacopoeia. For each project, designers must interview Using Agency personnel to evaluate the nature of drug compounding procedures, including risk level, for each compounding room, as the basis for determining required room air changes, filtration levels, protective equipment, and separation area (anteroom) requirements for the designated clean room level.

### **10-17 AIRBORNE INFECTION ISOLATION AND PROTECTIVE ENVIRONMENT ROOM DESIGN.**

Isolation rooms consist of airborne infection isolation and protective environment rooms. The former is intended for the patient suffering from a known or suspected infectious disease, and is provided with engineering controls that assist in preventing the spread of the disease from the room. Protective environment rooms are provided for the patient having an immune system deficiency, and require engineering controls to assist in protecting the patient from contamination from outside the room. Rooms must be one or the other, and not "switchable" from airborne infection isolation to protective environment function, or vice versa. Provide rooms with pressure-monitoring alarms and gauges mounted on the outside corridor wall; when a central DDC control operator's station is provided, the alarm should in addition be connected to that system.

#### **10-17.1 Airborne Infection Isolation Bedrooms.**

Airborne infection isolation bedrooms must be designed to incorporate requirements and guidance contained in the *Guidelines for Preventing the Transmission of Mycobacterium Tuberculosis in Health-Care Facilities* (the TB Guidelines), published in the Federal Register Vol. 59, No. 208. These rooms must be negatively pressurized and exhausted to the outside, and provided with the minimum total and outside air change rates (12/2, respectively) referenced in Appendix B Architectural and



Engineering Design Requirements. Exhaust ductwork from the bedrooms, the associated toilet, and the anteroom (if provided) must only be connected to the exhaust from other isolation rooms and their associated anterooms and toilet rooms, and not be connected with other exhaust systems. The exhaust system must be powered from the EES. Supply bedroom suites by air systems provided with constant-volume control and measuring terminal units that automatically maintain the supply airflow rate set-point to each space. Exhaust systems must be constant volume systems maintaining a fixed exhaust flow rate for each space. When bedroom exhaust is located such as to prevent re-entrainment into outside air intakes or other building openings, HEPA filtration of the exhaust is not required.

#### **10-17.1.1 Existing Facilities.**

In existing facilities, only those bedrooms designated by the facility specifically for use as tuberculosis isolation bedrooms are required to be designed in accordance with the TB Guidelines referenced in paragraph 10-17.1 Airborne Infection Isolation Bedrooms. TB Isolation bedrooms must be negatively pressurized and exhausted, and must be provided with 12 air changes per hour if economically or physically practicable. When not practicable to achieve this air change rate, TB isolation bedrooms must have a minimum of 6 air changes per hour, to be supplemented by HEPA filter or UV germicidal irradiation (UVGI) systems specifically designed for TB Room applications and providing the equivalent of an additional 6 air changes per hour. Fixed-in-place HEPA filtration units are preferable to portable units, and upper-level UVGI systems are preferred over duct-mounted units, to enhance reliability. Room exhaust must be conducted to the outside of the building; when designed to avoid re-entrainment into outside air intakes or other building openings, HEPA filtration of the exhaust is not required.

#### **10-17.1.2 Isolation Suite Relative Pressurization.**

When an anteroom is provided for the isolation bedroom interposing between the bedroom and corridor to provide a “buffer” airspace for additional protection, there are several recognized design approaches for corridor-anteroom-bedroom relative pressurization. A recommended design is to provide for the anteroom to be under negative pressure relative to the corridor, and positively pressurized relative to the bedroom.

#### **10-17.2 Protective Environment Rooms.**

The air supply to the protective environment room and associated anteroom and toilet room must be constant flow and must be provided with HEPA filtration. 12/2 total and outside air changes, respectively, are required for these rooms. As with airborne infection isolation bedrooms, there are several recognized approaches to the relative corridor-anteroom-bedroom pressurization; a recommended approach is to establish the anteroom positively pressurized relative to the corridor, and negatively pressurized relative to the bedroom.

When upgrading existing protective environment bedrooms to this criteria, 12/2 air changes per hour must be provided if economically and physically practicable. When

impractical, these bedrooms must be provided with a minimum of 6 total air changes per hour and supplemented by HEPA filtration or UVGI systems to provide the equivalent of 12 air changes.

**10-17.3 Airborne Infection Isolation Exam or Waiting Rooms.**

Airborne infection isolation exam or waiting rooms, including pediatric and emergency waiting rooms, must be provided with a minimum of 12 total air changes, as provided in Appendix B Architectural and Engineering Design Requirements. Exhaust ductwork from these rooms must only be connected to the exhaust from other isolation rooms and their associated anterooms and toilet rooms, and not be connected with other exhaust systems.

CANCELLED

## CHAPTER 11 ELECTRICAL

### 11-1 GENERAL.

#### 11-1.1 Scope.

This chapter provides DoDM policy and guidance for planning, designing, and construction of electrical power and illumination systems for Military Medical Facilities. References for general electrical and illuminating criteria are noted throughout the chapter, and included in Appendix A References and Appendix B Architectural and Engineering Requirements. References also include the General Building Requirements established by UFC 1-200-01, including the core Electrical Engineering UFC's. The core Electrical Engineering UFC's, of which UFC 3-501-01 is the top-level, in conjunction with criteria in this chapter, establish minimum design requirements. In the event of conflict this UFC is the ruling criteria.

#### 11-1.2 Supplemental Criteria and Standards.

This chapter may be supplemented with individual Using Agency criteria, including Installation-specific requirements, as established by the Design and Construction Agent.

##### 11-1.2.1 Seismic.

Essential electrical systems must be designed to function after seismic events occur. Non-essential systems may be inoperable following a seismic event, but components must be restrained to avoid personal injury or damage to other building components. Coordinate with the requirements for seismic design and AT/FP contained in other chapters of this document.

##### 11-1.2.2 Durability.

Installed electrical systems and electrical equipment must have a minimum rating for continuous full design load, except where other criteria mandate larger ratings, to meet the facility reliability requirements.

##### 11-1.2.3 Maintainability.

The design must provide a means to remove and maintain equipment and field-install wiring without interruption to essential electrical system loads, through the use of draw out equipment, by-pass switches, and space planning for maneuverability during servicing. Standard equipment and sizes must be used to the extent practical to allow interchangeability and simplify parts stock.

11-1.2.3.1 In new construction, distribution panels or equipment requiring limited access by NFPA 70, must be located in electrical rooms; exception is Universal X-ray room.

11-1.2.3.2 Draw-out breakers must be provided in standard sizes to allow interchangeability. Means must be provided to rack breakers in and out. Provide one spare unit in each frame size.

**11-1.2.4 Efficiency.**

The efficiency of the facility electrical system, measured at the utilization transformer secondary and the alternative power source, must have a power factor (PF) not less than 0.95 at nominal voltage for balanced three-phase loading (phase unbalance must not exceed 5 percent between A, B, and C phase). Where required, use the PF correction to ensure a minimum PF of 0.95.

**11-1.2.5 Economy.**

Evaluate alternative system configurations, and component types and sizing for economic value consistent with other criteria factors.

**11-1.2.6 Power Conditioning.**

Systems that incorporate solid-state devices are susceptible to electrical system transients that may cause system malfunction or equipment component damage. Power conditioning equipment must not be installed at the utilization point of the building electrical system, unless explicitly required for specific items of equipment by the Using Agency or by an A/E or designer evaluation of solid-state requirements for Intensive Care Areas and approved for installation by DHA/FE. CFCI systems that utilize solid-state devices must be provided with transient/surge protection. Static UPS must normally be provided with the equipment and system being served. However, UPS requirement or provisions must be determined on a project-by-project basis. Provisions for future installed power conditioning equipment must be determined on a project-by-project basis.

**11-1.2.7 Voltage Tolerance.**

Nominal voltage ratings and operating tolerances of the combined exterior and interior distribution system must comply with maximums and minimums established by ANSI C84.1. Designers will consider all system voltage drops in order to ensure voltage levels are met, from the high voltage main electric supply substation to the low voltage point of utilization. Normally automatic load tap changers in the high voltage main electric supply substation transformer must be provided for voltage regulation to respond to demand peaks; and where tolerances are still not met, voltage regulators must be provided within the facility. Voltage drop for branch circuits and feeders must be in accordance with UFC 3-501-01. Load current for calculation of voltage drop must be based on the circuit capacity as required by UFC 3-501-01; except for feeders, the frame size of replaceable plug units may be used for load current on adjustable breakers.

### **11-1.2.8 Risk Assessment for System Categories.**

A Risk Assessment must be performed in accordance with NFPA 99 to determine risk categories for activities, systems or equipment; and the essential power requirement. The results of this assessment must be used in conjunction with 11-4.16 and Appendix B Architectural and Engineering Design Requirements, "Essential Power Notes", to determine loads served and sizing of the alternate power source. The results of the assessment are in addition to the equipment otherwise prescriptively required within this UFC to be served by the essential electrical system. See Appendix C for the timing and responsibilities of the Risk Assessment.

### **11-1.2.9 Reliability.**

The design of essential electrical systems serving category 1 (critical care) spaces must provide for no single point of failure.

11-1.2.9.1 Each separate panelboard in Operating Rooms must be served by separate critical branch automatic transfer switches, including Appendix B Architectural and Engineering Design Requirements room codes with the essential power note "RA", which requires all receptacles on the essential branch.

11-1.2.9.2 Operating Rooms which are wet procedure locations must be supplied by independent isolated power panels.

### **11-1.2.10 Growth**

11-1.2.10.1 Load Capacity. At the completion of design, a minimum 20 percent spare load growth at 100 percent demand must be provided throughout the electrical system, to include primary feeders, transformers, generators, secondary feeders, and distribution equipment.

11-1.2.10.2 Empty Space. Provide a minimum of 20 percent empty (bus) space in all switchgear, switchboards, and panelboards.

11-1.2.10.3 Spare Breakers. Spare breakers must be provided for specific equipment where specified in other paragraphs.

11-1.2.10.4 Wall Space. A minimum 20 percent horizontal wall space, to include floor space for cubicle gear, must be provided within each separate electrical room for system expansion.

### **11-1.2.11 Elevators.**

Electrical design for elevators must comply with ASME A17.1 and UFC 3-490-06.

### **11-1.2.12 Alternative Energy Sources.**

If alternative energy sources such as fuel cells or photovoltaics are provided, they must be connected to the normal power system.

### **11-1.3 OCONUS Criteria**

OCONUS facilities must comply with requirements herein, except where alternative standards have been developed and approved in accordance with Chapter 1 Introduction. Alternative standards must achieve the intent of criteria without compromising safety or property. Consequently, the standards must include a full analysis of the respective codes, means, and methods, and be fully vetted with the Using Agency, the Installation, the Design and Construction Agents and their respective medical facilities technical offices.

#### **11-1.3.1 Federal Republic of Germany (FRG).**

The Hospital Electrical Systems Study (U.S. versus German Codes) must be incorporated into FRG projects in order to provide equivalent safety to U.S. construction and aid in Joint Commission certification. The study consists of a series of recommendations by subject and each recommendation must be considered a design or operational requirement, which either supplements or replaces criteria of this chapter. The study provides for the use of German codes, standards, equipment, materials, and construction practices; through the imposition of the more stringent requirement or the analysis of equivalent safety. The analysis of equivalent safety is based upon specific O&M procedures identified at the Landstuhl Regional Medical Center. These procedures include a comprehensive maintenance program through in-house forces, complete and annual testing of all systems, and a safety program. Consequently, the study only applies to facilities meeting these O&M requirements as identified within the study. A copy of the study is available on the World Class Facilities Toolkit or upon request from CEHNC-EDX.

### **11-2 AREA DESIGNATIONS.**

#### **11-2.1 Patient Care Space.**

NFPA 70 and NFPA 99 establish minimum safety practices and requirements for patient care spaces. "Critical", "General", "Basic" and "Support" patient care spaces are identified in Appendix B Architectural and Engineering Design Requirements by NFPA 99 category code 1 through 4. Note: medical research facilities, laboratories and veterinary facilities must comply with NFPA 99 and NFPA 70 article 517 even though an exclusion is provided in these codes for care not rendered to human beings.

#### **11-2.2 Wet Locations.**

Wet locations are those patient care areas that are normally subject to wet conditions, including areas with standing water on the floor or areas where routine dousing or drenching of work spaces is performed, and those areas defined in NFPA 99 and NFPA 70. However, wet conditions as a result of routine housekeeping procedures or an incidental spill of liquid are not considered wet locations.

### **11-2.3 Wet Procedure Locations**

Wet Procedure Locations are defined in NFPA 99. The Using Agency must perform a risk analysis in accordance with NFPA 99 to determine which Operating Rooms or other patient care areas must be designated as wet procedure locations. These wet procedure locations must be included in the project requirements documents.

### **11-3 EXTERIOR ELECTRICAL.**

Exterior electrical systems must conform to IEEE C2, except where technical criteria are more stringent.

#### **11-3.1 Primary Voltage.**

Common primary distribution voltages for Military Installations are 4.16 kilovolts (kV), 12.47 kV, 13.2 kV, 13.8 kV, and 34.5 kV. However, 12.47 kV, 13.2 kV, and 13.8 kV are the normal primary distribution voltages serving Military Medical Facilities.

#### **11-3.2 Normal Source Site Investigation.**

Site electrical evaluations must meet the requirements within this document. Coordinate electrical utility siting with other utilities. Provide underground distribution on site and visual screening by location or landscaping elements where appropriate for the project to improve overall site aesthetics.

#### **11-3.3 Hospital Normal System.**

11-3.3.1 Hospitals must be served by two primary feeders, each serving one end of a double-ended substation or to a selector switch serving a multi-ended network substation (Reference Annexes B and C at the end of this chapter for additional criteria related to substation design). Each feeder must be able to carry the full hospital demand, plus 20 percent spare load growth at 100 percent demand, and must be installed in an underground, concrete-encased duct bank within the hospital site. Primary feeders must be connected to different power sources (main electric supply substations) if available, and the two primary feeders must be differently routed such that they are electrically and geographically separated. Where two main electric supply substations are not available, the service feeders may be connected to two different sections of a true open loop system.

11-3.3.2 A true open loop system configuration is a utility primary feeder where both ends originate from different main electric supply substations or switching stations, or different breakers and transformers in the same main electric supply substation, and have the capacity to serve the total loop load from either end. Consider both the main electric supply substation primary (high voltage) and secondary (medium voltage) loop configuration, redundancy within the main electric supply substation design (e.g. double ended), and outage history in the overall reliability determination. The Government and Public Utility each have defined responsibilities (ownership), and where reliability does not meet standards, provide normal power back up of systems to sustain operations if requested by the Using Agency.

Figure 11-1 Hospital One-line Traditional Diagram

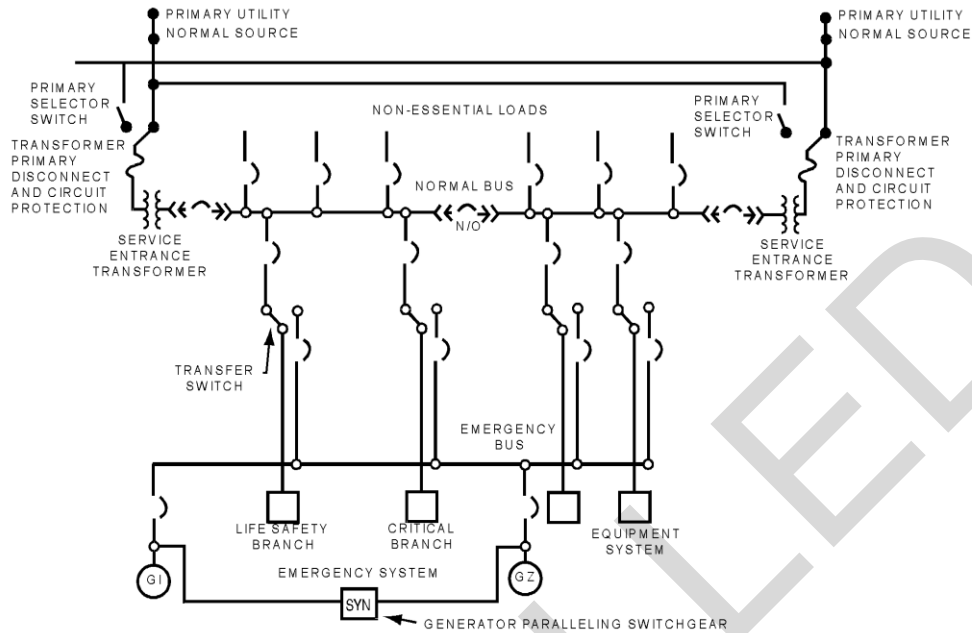

11-3.3.3 A manually-operated primary selector switch and fused load break disconnect switch must be provided for each transformer as indicated in Figure 11-1. Transformers must normally be located outside the hospital but may be located within the building where practicable and economical. Double-ended unit substation distribution systems must be designed for hospitals, medical centers, and specially-designated facilities. The double-ended substation configuration must be arranged for easy expansion from each end. The tiebreaker and main feeder breakers of double-ended substations must be identical and interchangeable. All double-ended and single-ended substation breakers (tie, main feeder, and sub-feeder) must be draw-out power class. Each transformer in the double-ended unit substation must be sized to serve approximately 60–70 percent of the substation demand load (linear and nonlinear) before forced air cooling is initiated, at 100 percent of demand load plus 20 percent future load growth with forced air cooling initiated, and must be impedance-matched. All double-ended unit substations must have coordinated transient/surge and fault protection. System protection must be selective. Design all double-ended substations for normal open tie breaker operation, which is interlocked with the main breakers, so that all three breakers “main-tie-main” cannot be closed simultaneously. Upon loss of a single transformer or its feeder, the main breaker is automatically opened and the tie breaker is automatically closed to add its load to the remaining transformer.

11-3.3.4 To prevent unnecessary generator starting due to loss of only one of the two normal power sources, an ATS connected to both normal sources must provide normal power to the fire pump controller.



#### **11-3.4 Outpatient Clinics Normal System.**

All free-standing or physically separate Military Medical Facilities must be served by a single-ended substation distribution system with coordinated transient/surge and fault protection.

#### **11-3.5 Ambulatory Healthcare Centers Normal System.**

Ambulatory Healthcare Centers with Operating Rooms must be served with dual sources of normal power as described in paragraph 11-3.3, Hospital Normal System. Ambulatory Healthcare Centers without Operating Rooms must be served by a single-ended substation as described in paragraph 11-3.4, Outpatient Clinics Normal System.

#### **11-3.6 Grounding.**

System ground must be adequate for safety and for reliable operation of sensitive users and facility equipment. Typical communications system equipment used in hospitals requires 5-ohm system ground for proper operation. All grounding systems must be bonded together as required by NFPA 70.

### **11-4 ESSENTIAL ELECTRICAL SYSTEM.**

#### **11-4.1 Facility.**

##### **11-4.1.1 Ambulatory Healthcare Centers.**

Ambulatory Healthcare Centers with Operating Rooms must comply with the requirements of paragraph 11-4.1.5, Hospitals. Ambulatory Healthcare Centers without Operating Rooms must comply with paragraph 11-4.1.4, Medical and Dental Clinic.

##### **11-4.1.2 Medical Research Facilities and Laboratories.**

During the planning and programming phase the Using Agency shall provide justification to DHA/FE for an emergency generator. An essential electrical system will be required if the facility contains category 1 or 2 spaces; refer to the patient care space categories in Appendix B. The essential electrical system must comply with NFPA 99 and NFPA 70 article 517, even though an exclusion is provided in these codes for care not rendered to human beings. If category 1 spaces are present, comply with the requirements of paragraph 11-4.1.5 Hospitals, else comply with the requirements of paragraph 11-4.1.4 Medical and Dental Clinics.

##### **11-4.1.3 Veterinary Facilities.**

During the planning and programming phase the Using Agency shall provide justification to DHA/FE for an emergency generator. An essential electrical system with an alternate source of power will be required if the facility contains category 1 or 2 spaces; refer to the patient care space categories in Appendix B. The essential electrical system for veterinary facilities shall comply with NFPA 70 and NFPA 99, even though an exclusion is provided in these codes for veterinary care. The design of the

essential electrical system shall be in accordance with the requirements in this chapter as modified by the project authorization documents to include the DD1391. If category 1 spaces are present, comply with paragraph 11-4.1.5 Hospitals, else comply with the requirements of paragraph 11-4.1.4 Medical and Dental Clinics.

#### **11-4.1.4 Medical and Dental Clinic.**

11-4.1.4.1 During the planning and programming phase for Medical and Dental Clinics if an emergency generator is desired, the Using Agency must provide justification (LCC, mission requirements, geographic location, etc.) to DHA/FE. An essential electrical system, with an alternate source of power, will be required if the facility contains category 1 or 2 spaces; refer to the patient care space categories in Appendix B. For the intent of this section, this essential electrical system only provides for cessation of procedures upon loss of normal power.

11-4.1.4.2 An essential electrical system is not required if the facility does not include category 1 or 2 patient care spaces. However, if category 1 spaces are present, a Type 1 essential electrical system must be provided to serve those spaces; and if category 2 spaces are present, a Type 1 or 2 system must be provided to serve these spaces. If the facility includes areas designated ambulatory, for example egress or refuge, the life safety branch of the essential electrical system must also serve these areas. Type 1 and 2 systems are defined by NFPA 99. Each includes a life safety and equipment branch, however the Type 1 system also includes a critical branch.

11-4.1.4.3 The essential electrical system alternate power source must be a generator or battery system. If a battery system, it must have the capacity to sustain full connected load at rated voltage for a minimum of 1-1/2 hours. If the load is 150 kVA or less, a single generator set may be used, and a single transfer switch is permitted by NFPA 70. For the single generator set a skid mount tank is preferred and the fuel supply is to be no less than 8 hours at full load. An exterior enclosure may be considered for the single generator set, provided it is screened to be architecturally compatible with building and grounds, and is sound attenuating. The system must be arranged such that the alternate power source must automatically connect to the load within 10 seconds. The essential electrical system must supply power for life safety, task and task focus illumination, outlets related to patient safety, and mechanical equipment as determined by the NFPA 99 risk assessment. This typically includes but is not limited to dental surgical vacuum, dental air, waste anesthetic gas disposal, and any other system or equipment which is necessary for safe and orderly cessation of procedures and all related anesthesia and resuscitation equipment. Electric driven fire pumps must be supplied with essential power unless an analysis in accordance with NFPA 20 and UFC 3-600-01 is provided to prove reliability of the normal power supply. Otherwise, as exempted in the above paragraphs, the essential electrical system must conform to paragraph 11-4.1.5 Hospitals.

#### **11-4.1.5 Hospitals.**

Hospitals must be provided with an essential electrical system in compliance with this chapter.

#### **11-4.2 General.**

The alternate power source must conform to NFPA 70 and NFPA 99, except where technical criteria from the Using Agency is more stringent. Provide adjustable trip spare circuit breakers, raceway, and buss bar connection box for load bank testing. Load bank breaker must be sized for 100 percent capacity of one generator set; and a second breaker, 100A three phase, must be provided for the load bank fans. Cable to be provided by user after turnover. Provide additional load capacity to those hospitals assigned mobilization or mass casualty response missions as identified in the project DD Form 1391. The emergency power source must be designed as a separately derived power source. True root mean square (RMS) metering must be provided for load monitoring.

#### **11-4.3 Alternate Power Source.**

The alternate power source must supply the essential electrical system during interruption of the normal source as required by NFPA 70 and NFPA 99. The design must consist of two or more generator sets to provide parallel operation in accordance with Figure 11-1 (see Annex B and C for alternate configurations); except where the essential electrical system load is 150 kVA or less, one generator set may be considered. Factory service, parts, and supplier support must be a design consideration.

When operating in parallel, generator sets must be of equal capacity and rating with matched impedance and loss characteristics, and designed to carry in parallel or through priority transfer equipment the maximum demand load (linear and nonlinear) of the essential electrical system. Motor starting and X-ray unit momentary kVA loads must be evaluated when sizing generator sets. Each generator set must have the capacity to serve all non-sheddable loads (life safety and critical branches, medical air compressor, medical-surgical vacuum pumps, jockey pumps, fire pumps, generator set fuel pumps, other generator set accessories, and non-sheddable helipad loads) plus 20 percent future load growth at 100 percent demand. The generator set performance class and transient limits must comply with UFC 3-540-01, and block loading calculations must be included in the project documentation. Hospitals built under the 1971 version of NFPA 70 may have a life-support branch that is the second critical branch supplied by a separate ATS.

#### **11-4.4 Load Shed Restoration System.**

Hospitals and Ambulatory Healthcare Centers with Operating Rooms must have a load shed restoration system. The design must provide automatic load shedding with manual override capability that will commence in the event one generator set were to fail or the total essential load were to exceed a preset value beyond which a cascading shutdown could occur. The system must be designed in accordance with UFC 3-540-01, include automatic and manual means of operation, and provide for load prioritization by operation and maintenance. The system must be independent of and not share wiring or control with other building systems. Switching must allow isolation of NFPA 99 non-sheddable loads. Load switching is usually through ATS's but may include motor

operated breakers. The design must include a prioritization table by load switched with kVA, priority, sequence, and time delay.

**11-4.5 Generator Sets.**

Generator sets must be powered by diesel fuel and conform to Table 11-1. The preferred generating voltage is the highest utilization voltage proposed for the facility. Normally, 480Y/277 volt (V), 3-phase, 60 Hertz (Hz), 4-wire system is the highest utilization voltage. Higher voltages may be generated where line losses would otherwise be excessive. Generator sets must include automatic start-and-stop equipment, solid-state battery chargers, fuel storage tanks, and audible and visual warning devices to alert of less than four hours of fuel supply and day tanks and radiators (as required). Provide the generator set with a hospital grade exhaust silencer and the ability to start and assume its full electrical loads within 10 seconds from the interruption of the normal source. Provide protective relaying for generator sets and related equipment in accordance with the recommendations of IEEE STD 242, including reverse power relays in accordance with NFPA 110 to prevent damage from commercial power or other onsite generators. All generator sets must be equipped with an isochronous governor to ensure stable voltage, frequency, and power by preventing erratic load operations and allowing computerized equipment to operate directly from the essential electrical system.

**Table 11-1 Continuous and Emergency-Rated Diesel-Electric Generator Sets for Military Medical Facilities**

<b>Power Class Categories:</b>
1. <b>Prime Power Class</b> engines are for use with diesel-electric generator sets expected to provide power on a continuous basis, i.e., in excess of 4,000 hours annually or in excess of 40,000 hours during the initial 10 years of operation, to serve as the sole or primary source of power.
2. <b>Standby Power Class</b> engines are for use with diesel-electric generator sets expected to provide power on a standby basis for a significant number of hours each year, i.e., between 1,000 and 4,000 hours annually or between 10,000 and 40,000 hours during the initial 10 years of operation.
3. <b>Emergency Power Class</b> engines are for use with diesel-electric generator sets expected to provide power on an emergency basis for a short period of time, i.e., less than 1,000 hours annually or less than 10,000 hours during the initial 10 years of operation.

<b>DESIGN APPLICATION:</b>
1. For 50-Hz power, the indicated speed limits should be reduced to the nearest synchronous speed for that frequency.
2. Hospital and Ambulatory Healthcare Center diesel-electric generator sets are normally Emergency Power Class.
3. Hospital and Ambulatory Healthcare Center diesel-electric generator sets used for co-generation must be either Prime Power Class or Standby Power Class.

#### **11-4.6 Location of Generator Sets.**

Generator sets must be located in the central utility, provided it is sufficiently close to minimize line losses and cable runs. When the central utility plant is remote from the medical structure, locate generator sets in a building adjacent to or within the medical structure. Generator sets and related switch gear rooms (auxiliaries) must be located near the building exterior to facilitate installation and replacement of equipment. Generator sets and auxiliaries must be arranged so minimum facility modifications are required for future installation or replacement. Service entrance transformers and other equipment not supporting the essential electrical system must not be installed in the same area (room) as the generator sets. Provide a view window in, or adjacent to, the entrance door.

Generator sets and auxiliaries shall not be located below finish-grade level and shall be directly accessible from the facility's interior and exterior to a vehicular way. In regions subject to flooding, provide flood proofing in accordance with paragraph 11-5.4.2 and locate equipment above the Design Flood Elevation.

#### **11-4.7 Engine Starting.**

Electric or pneumatic starting for generator sets must conform to NFPA 70, NFPA 99, and NFPA 110. Where electric start is used, provide dual heavy-duty electric starters on generator sets above 1,250 kVA.

#### **11-4.8 Manual Test Switches.**

Manual test switches must be provided for each ATS of the essential electrical system. A group of test switches must be provided at a single point in the generator set control area, and one test switch must be provided with each ATS. The two test switches associated with each ATS must be wired in series to allow testing at either location. Testing of either individual ATS or the entire essential electrical system must be possible. Each test switch must simulate a normal power source failure and automatically cause the generator sets to crank, to attain rated frequency and voltage, and to transfer associated essential electrical system loads from the normal source to the alternate power source. After 30 minutes of operation in the emergency mode, essential electrical system loads being tested must again be automatically transferred back to the normal source. If, for any reason, the generator sets experience difficulty while in the emergency mode, the load must immediately be transferred to the normal source automatically. During this test run, nonessential hospital loads must continue to

be served from normal source without interruption. Install a manual override switch that can be actuated to keep essential hospital loads on the alternate power source as long as desired. This switch must permit generator sets to operate indefinitely beyond the 30 minute automatic transfer restoration time.

#### **11-4.9 Generator Set Operation.**

11-4.9.1 Generator sets must be designed to function as discussed here: After one second following interruption of the normal source, each generator set must receive the starting signal simultaneously from the ATS, whereupon each generator set must automatically crank and attain normal speed and voltage. Do not bundle the starting signal together or series connect between ATS's. Voltage for sensing devices to start generator sets must be taken from each phase of the incoming normal power terminal of each ATS and must be hardwired back to the generator set start controls. The first generator sets to reach preset voltage and frequency conditions must be automatically connected to the emergency bus.

11-4.9.2 System protection must be provided to prevent simultaneous connection of non-synchronized generator sets to the dead emergency bus. A priority selective device must be provided and programmed or preset to transfer the non-sheddable loads from the normal bus to the emergency bus within 10 seconds from time of normal source interruption. The remaining generator set(s) must automatically synchronize with the emergency bus, close the respective generator SET breaker, and connect the generator sets in parallel for normal operation. After this, the equipment system loads must be automatically transferred to the emergency bus by programmed or preset incremental steps.

11-4.9.3 Should one or more of the generator sets fail to crank or is shut down for any reason during the operation, the remaining generator set(s) must be scheduled to serve only the non-sheddable loads and, if possible, highest priority equipment system loads until the failed unit is energized and connected to the emergency bus. For such a condition, a programming device must shed all or part of the equipment loads to keep the remaining generator within its kW rating. A manual start switch must be provided to override the automatic start of the generator sets so they can be cranked, synchronized, and connected on the emergency bus. Provide manual controls to allow the synchronizing and paralleling of the generator sets.

#### **11-4.10 Return to Normal Power Source.**

Thirty minutes following the return of a stable, normal source, essential system loads must be automatically transferred to the normal source. An automatic timer, having an adjustable time range from 2 to 30 minutes (set at 30 minutes), must be provided for this transfer. Following transfer of the loads, generator sets must continue to run, unloaded, for a period of not less than 15 minutes for cool-down before shutdown, after which the controls must automatically reset for a new cycle. A manual start switch must override the automatic start of generator sets so they can be manually cranked, synchronized, and connected to the emergency bus if automatic controls fail.

#### **11-4.11 Automatic Transfer Switch (ATS).**

All ATSS must be double-throw (open transition) with draw-out construction. Four-pole ATSS must be used when serving line-to-neutral loads or a combination of line-to-neutral and line-to-line three-phase loads. Three-pole ATSS must be used when serving only three-phase line-to-line load. Contacts must have viewing ports for ease of contact inspection. ATSS must be Underwriter's Laboratory (UL)-tested with the main up-stream breaker to ensure coordinated withstand compatibility between the ATSS and the interruption time of the breakers. Circuit-breaker-type transfer switches are not acceptable. Each ATSS must have green indicator lights to identify normal power and red to identify emergency power. Provide each ATSS with at least three normally open and three normally closed spare shaft contacts. All ATSS must be equipped with a load break BP/IS to maintain normal or emergency power while the ATSS is being repaired or maintained. (The BP/IS must be initiated with not more than two movements of the hand to either position regardless of the position or condition of the ATSS.) Load bypass to the ATSS connected source must be achieved with either no load interruption or a load interruption of not more than 10 Hz (cycles). ATSS feeding high efficiency motors rated 25 hp or larger must be provided with an in-phase monitor to prevent an out-of-phase transfer. The in-phase transfer must be achieved without control of the frequency of either power source to prevent excessive motor in-rush current. Use of closed-transition switching for facilitating essential system testing requires special justification and approval. The BP/IS for the ATSS serving nonessential equipment can be optional.

##### **11-4.11.1 ATS and BP/IS Location.**

For Hospital and Ambulatory Healthcare Center facilities, locate the ATSS and BP/IS equipment in a separate two-hour fire-rated room with direct access from the normal main power equipment room and the alternate power source equipment room.

##### **11-4.11.2 ATS and BP/IS Testing.**

Laboratory testing, e.g., UL, Factory Mutual (FM), or other nationally recognized authority, must be conducted on the ATSS and BP/IS equipment, unless it was completed on a previous randomly selected standard production unit of the same model and capacity as the specified ATSS and BP/IS equipment. Conduct the overload, endurance, and temperature tests (in sequence) as listed here.

- a. General
- b. Normal Operation
- c. Overvoltage
- d. Under-voltage
- e. Overload
- f. Endurance

- g. Temperature Rise
- h. Dielectric Voltage – Withstand
- i. Contact Opening
- j. Dielectric Voltage – Withstand (Repeated)
- k. Withstand
- l. Instrumentation and Calibration of High Capacity Circuits
- m. Closing
- n. Dielectric Voltage – Withstand (Repeated)
- o. Strength of Insulating Base and Support

It is important to note that no deviations from the test sequence are permitted. Approval must not be granted to deviate from the overload, endurance, and temperature test sequence.

#### **11-4.12 Ground Fault Protection Equipment.**

The essential electrical system must not be provided with ground fault protection devices. The generator circuit breaker and essential electrical main distribution board circuit breaker must be provided with ground fault detection features, when required, to indicate a ground fault and sound an audible alarm but not trip the breaker. Each ground fault alarm sensor level must be activated when the ground fault current is 10 percent of the breaker rating or 50 amperes (A), whichever is more.

#### **11-4.13 Remote Alarm Annunciator.**

A remote alarm annunciator that receives power from a storage battery must be provided in a location readily observed by operating personnel at a regular workstation. The annunciator must indicate alarm conditions of the alternate power source, as indicated in NFPA 99 and NFPA 110, and must include (but is not limited to): battery and battery charger malfunction, engine generator run status, engine generator alarms, and less than a three-hour fuel supply in the day tank and 24-hour supply in the main storage tank. A separate audible and visible derangement signal must be provided within the hospital at a continuously monitored location. Reference Chapter 12 Communications for details. This derangement signal must be appropriately labeled but need not display individual alarm conditions.

#### **11-4.14 Fuel Storage Tanks.**

11-4.14.1 The fuel storage tanks and installations must comply with NFPA 30 and local, state, and Federal environmental protection policies or regulations. The capacity of the fuel oil tank must be sized to the nearest standard size for fuel storage; normal



usage must be a four-day supply at full load. For remote locations OCONUS and for prime power projects, fuel storage capacities may be larger based on mission requirements or risk analysis as determined by the Using Agency. If underground fuel storage tanks are required, they must be double-walled with leak detection in accordance with EPA standards. Provide separate day tanks, with an overflow back to the main storage tank, for each generator set, and the design must allow for not less than four hours of operation at full load. Fuel usage at full load must be based on manufacturer's full load test data. Follow NFPA 37 for fuel tanks inside of structures.

11-4.14.2 A set of duplex transfer pumps must be provided for each main fuel storage tank. Each fuel transfer pump must be sized to accommodate all generator sets, including a future generator set. All electric fuel tank and related fuel transfer pumps must have power available at all times. Each of the duplex fuel transfer pumps must be connected to the life safety branch and the non-delayed equipment ATSS. Provide fuel-filtering equipment as recommended for the generator sets and the local site conditions. Natural gas or comparable gas fuel must not be used as an operating fuel for hospital emergency power generation.

11-4.14.3 Warning: No. 2 Diesel Fuel may be used in lieu of No. 2 Heating Fuel. However, No. 2 Heating Fuel must not be used in emergencies as a substitute for No. 2 Diesel Fuel, unless the flash point is 125 degrees F, the cetane number is 40, and the average British thermal unit (Btu) per gallon is 141,800. (Reference ASTM D975 for details.)

#### **11-4.15 Loads on the Alternate Source.**

The alternate power source must have sufficient capacity to supply the essential Military Medical Facility's electrical system as outlined in NFPA 70 and NFPA 99, as modified herein, and as required by items listed in Appendix B Architectural and Engineering Design Requirements. Avoid oversizing generator sets such that load banks are necessary for testing under load as required by accreditation authorities. It is important to note that operating generator sets at low loads leads to fouled combustion and unreliable performance. The essential electrical system consists of three parts:

- a. Life safety branch – The life safety branch must have no loads connected to it other than those loads identified in NFPA 70 and NFPA 99.
- b. Critical branch – The failure of a critical branch's component between the area and the transfer switch could render the entire section without power. The power and lighting loads for the areas noted here must be connected to the critical branch for all patient care areas identified in 11-2.1, NFPA 70 and NFPA 99, of this document, as well as areas for pharmacy dispensing.
- c. Equipment branch – The essential equipment branch must serve all essential equipment listed in NFPA 70 and NFPA 99.

Supplying a mixture of normal, critical, and equipment branch power to Critical Care Areas is more reliable and is recommended in NFPA 99. Additional loads may be added to the critical branch or equipment system by the Using Agency as needed to improve Military Medical Facility operations.

#### **11-4.16 Essential Loads.**

Essential loads are divided into three categories: life safety, critical, and equipment. These loads receive both normal and emergency power. However, dual sources of critical power, originating from separate critical branch transfer switches, are required in some areas by Appendix B Architectural and Engineering Design Requirements; except where the essential system is 150kVA or less and a single transfer switch, the dual sources may be critical and normal. Essential branch assignment for telecommunication systems is specified in Chapter 12 Communications.

##### **11-4.16.1 Life Safety Branch Loads.**

The life safety branch provides emergency power to ensure patient and personnel safety during the interruption of normal power source. The lighting, receptacle, and equipment limitations listed here are defined by NFPA 70 and NFPA 99. Designers must refer to the latest editions. Life safety branch provides power to the following:

11-4.16.1.1 Egress illumination, which includes 25 percent of corridor and 50 percent of stairway illumination, plus 25 percent of assembly areas, such as dining rooms.

11-4.16.1.2 All battery chargers for emergency battery-powered lighting units used in the event of a life safety branch outage.

11-4.16.1.3 Exit signs that are selected to provide visibility in smoke conditions and must be operational in the event of a life safety branch outage.

11-4.16.1.4 Fire alarm and piped medical gas alarm systems, including smoke detectors, medical vacuum system alarms, and alarms for ventilation for smoke evacuation for those areas where patient evacuation is not feasible.

11-4.16.1.5 Emergency communications used to notify the general population (radio paging [RP] and intercom systems) including telephone system, power and lighting for communication closets and crisis control centers, and associated equipment. Various related systems are included as directed.

11-4.16.1.6 Selected power, task lighting, and receptacles at generator set locations; in transformer, switchboard, mechanical, and electrical equipment rooms; repair shops and other equipment rooms; and charger for battery-powered emergency light sets.

11-4.16.1.7 Elevator cab lighting, control, communication, and signal systems.

11-4.16.1.8 Electric-powered doors used for building egress.

11-4.16.1.9 Auxiliary functions of fire alarm mass notification systems complying with NFPA 72.

11-4.16.1.10 Fuel transfer pump, battery charger, jacket water heaters, alarms, controls, air compressors for pneumatic start, and other similar generator systems accessories essential for generator operation.

#### **11-4.16.2 Critical Branch Loads.**

The critical branch of the essential electrical system alternate power must supply task illumination, fixed equipment, selected receptacles, and special power circuits serving areas and functions related to inpatient care during the interruption of normal power as listed here, derived from NFPA 70 and NFPA 99. Designers must refer to the latest editions. The critical branch provides power to the following:

11-4.16.2.1 NC, telephone equipment rooms and closets, and selected computer equipment and selected data outlets.

11-4.16.2.2 Oxygen and medical gases equipment, MV pumps, and medical surgical compressed air system, and surgical vacuum pumps.

11-4.16.2.3 In patient rooms (on inpatient nursing units), one duplex receptacle must be provided per bed, including mobilization beds, located in the patient service console. Two additional wall-mounted duplex receptacles must be provided in single bedrooms and pediatric bedrooms.

11-4.16.2.4 Receptacles in nursery isolation rooms, cystoscopy, intravenous pyelogram (IVP) rooms, cardiac catheterization room, radiographic special procedure rooms, oral surgery room, and recovery rooms as indicated in Appendix B Architectural and Engineering Design Requirements.

11-4.16.2.5 All receptacles and hard wired equipment in selected rooms in the surgery suite, the delivery suite, Nursery, Coronary Care Unit, ICUs, hemodialysis, and emergency department rooms/spaces as required by Appendix B Architectural and Engineering Design Requirements.

11-4.16.2.6 All equipment for the refrigerated storage of blood, biological, and pathology specimens, and medicines.

11-4.16.2.7 Two X-ray rooms (including one fluoroscopic room) and required automatic X-ray film processor station.

11-4.16.2.8 Laboratories, incubators, analysis, blood bank, bone and tissue banks, chemistry, hematology, plus selected receptacles.

11-4.16.2.9 One flash sterilizer in each surgical suite and delivery suite cluster core and in Central Sterilization.

11-4.16.2.10 Selected receptacles in admitting and disposition, pharmacy, treatment rooms, nurse stations, oral surgery rooms, maxillofacial surgery, periodontic and endodontic clinic treatment areas with centrally-piped medical gas outlets.

11-4.16.2.11 Medical preparation stations and nourishment stations.

11-4.16.2.12 Electronic data equipment for patient records.

### **11-4.16.3 Equipment Branch Loads.**

Equipment branch feeders and branch circuits connected to the emergency and alternate power source must automatically supply loads in a delayed selective order through ATSS. The equipment list noted here is derived from NFPA 99 and NFPA 70. Designers must refer to the latest editions. The equipment branch provides power to the following subparagraphs:

If night/twilight operations are required, 15 minutes of battery backup must be provided to obtain no-break system and must be connected as a Priority 2 load. Where helipad operations are essential, provide a Priority 1 non-sheddable equipment connection.

11-4.16.3.1 One passenger type and one hospital service elevator per hospital wing (or section if applicable) to operate on a selective basis.

11-4.16.3.2 Fire pumps, jockey pumps, and controls (non-sheddable loads); with own listed controller and configured for 10 second start-transfer. See exception, paragraph 11-4.1.5, Medical and Dental Clinic.

11-4.16.3.3 Food service refrigeration, morgue refrigeration, pharmacy, laboratory, research, and other locations as determined by risk analysis of the Using Agency.

11-4.16.3.4 Essential power for auxiliaries and controls to provide safe operation of the heating plant.

11-4.16.3.5 Medical vacuum, waste anesthesia evacuation, and medical air system.

11-4.16.3.6 Dental vacuum, dental air, and waste anesthesia gas disposal serving category 2 spaces for oral surgery and comprehensive treatment as determined by the Using Agency and NFPA 99 risk assessment.

11-4.16.3.7 HVAC systems, including cooling and heating equipment and controls for all Critical Care Areas per Chapter 10 Heating, Ventilation, and Air Conditioning.

11-4.16.3.8 Domestic water, sump, and sewage equipment necessary for continuous hospital operations.

11-4.16.3.9 Special purpose exhaust systems, hoods in laboratories including radioisotope hoods, and isolation room exhaust fans.

11-4.16.3.10 The pneumatic tube system (PTS).

11-4.16.3.11 Helipad lighting and visual navigational aids.

#### **11-4.17 Alternate Source Testing.**

Alternate power source essential electrical systems must be tested for proper operation before final acceptance, as required by NFPA 99 and 110. All connected loads must be made operational, and must be operated within normal demand load tolerances. Alternate power systems must be designed to facilitate periodic system-wide and component testing and inspection.

### **11-5 INTERIOR ELECTRICAL SYSTEMS.**

Interior electrical systems must conform to NFPA codes, except where technical criteria from UFC 3-520-01 and this document are more stringent. All conductors used in the construction of Military Medical Facilities and medical research facilities must be copper. All bus used in switchgear, switchboards, panelboards, and for grounding points must be copper. All transformers inside the building must have copper windings.

#### **11-5.1 Utilization Voltage.**

480Y/277 V, 460 V, 208Y/120 V, 240 V, and 120 V low voltages, and 4.16 kV and 6.9 kV medium voltages are common utilization voltages found at Military Installations. However, 480Y/277 V and 208Y/120 V are the standard utilization voltages for new and existing Military Medical Facilities. Only chillers may be served by medium voltage, and when so must be supported by separate generators that are not part of the essential electrical system.

#### **11-5.2 Interior Distribution.**

##### **11-5.2.1 Utilization Voltage**

Interior lighting and power loads must be served at the highest voltage practicable. Fluorescent and high intensity discharge (HID) lighting systems and building power loads must be supplied by a 480Y/277 V system. Dry-type transformers must be used to furnish 208Y/120 V power for receptacles and small equipment loads. A 208Y/120 V system must be provided where the use of higher voltage is not cost effective.

##### **11-5.2.2 Transformers**

Dry-type transformers must be in accordance with UFC 3-520-01 and TSEWG TP-5, using de-rating, harmonic mitigating, or K-Factor transformers for non-linear loads. Analyze non-linear loads in each building area using Table 11-2 sample analysis matrix. Where transformer-type voltage regulators are used to maintain nominal voltage within  $\pm 5$  percent (see paragraph, Voltage Tolerance), an automatic step or induction transformer regulator with adjustable high- and low-voltage limit controls and a voltage meter must be used.

Table 11-2 Sample Nonlinear Load Analysis Matrix

Service Module Type	Total Recept. kVA	Estimated Non-Linear kVA	Module XFMR Size	Non-Linear Percent Of Total kVA	XFMR Rating
Clinic					
Logistics					
Dentistry					
Pulmonary					
ICU					
Surgery					
Food Service					
Labor/Delivery					
CCU					
ICU					
Orthodontics					
Physical Therapy (PT)					
CMS					
Nuclear Medicine					
Emergency					
Waste Management					
Materials					
Radiology					
Collecting Labs					
Pathology					
Chemistry Laboratory					
Pharmacy					
Social Work					
Auditorium					
Patient Services					
Nursing (3 Mods)					
Administration					

### 11-5.2.3 Switchgear, Switchboards, and Panelboards

In this chapter switchgear, switchboards, and panelboards conform to definitions in NFPA 70. Switchgear below 1000 volts is metal enclosed and above 1000 volts metal

clad per IEEE C37.20 series of standards. In Hospitals and Ambulatory Healthcare Centers with Operating Rooms, use switchgear with draw-out, solid-state, adjustable trip circuit breakers for:

- Main distribution, including unit substations and essential system supply.
- Feeder distribution, including sub-mains for areas or groups, or similarly the first level below an ATS.

Draw-out breakers must be similarly provided in other facilities which are operated 24/7 or in which buss work is 2000 amperes or more. Use switchboards in other facilities with low voltage services 1200 amperes or more. Panelboards for branch circuits must be bolt-on type circuit breaker equipped. Ground fault protection, including ground fault protection of the essential electrical system, must be provided in accordance with NFPA 70 and NFPA 99.

### **11-5.3 Short Circuit, Selective Coordination, and Arc Flash.**

Short-circuit, protective devices coordination, and arc flash studies must be conducted in accordance with UFC 3-501-01 and NFPA 99. The studies must be conducted in the design stage and again in the construction stage with the actual equipment installed. The studies must provide protective devices settings. Selection of protective devices and equipment for a new electrical system must be based on the analysis. For additions or modifications to an existing system, the analysis must include all the protective devices affected in the existing system. All protective devices must be coordinated for selective overload (beyond 0.1 second), short circuit, and ground fault protection. No series rated protective equipment or devices must be allowed. Transient/surge protection should also be incorporated in the selective coordination analysis.

### **11-5.4 Electrical Rooms.**

#### **11-5.4.1 Main Equipment Rooms.**

Main equipment rooms must be provided with direct exterior access to a vehicular pathway to facilitate initial installation of large equipment, removal and replacement of defective equipment, and to provide ease of access by the Installation's maintenance forces. Also main equipment rooms must be directly accessible from the facility's interior. Main equipment rooms include service points, rooms with generators, rooms with medium voltage transformers, and rooms with large equipment assemblies.

#### **11-5.4.2 Flood Proofing of Electrical Rooms**

Electrical rooms should be above grade for access and reliability of equipment; though may be located below grade, provided the location naturally drains above the design flood elevation (DFE) and flood resistant construction is provided below DFE in accordance with IBC section 1612 and ASCE 24. For the intent of this paragraph, natural drainage is defined as not dependent upon a sewer line, which may back up;

and where impractical to provide natural drainage, slope floors to sumps affixed with alternating duplex pumps on essential power and elevate equipment on pads 8 inches above floor level. DFE must be no less than 2 feet above base flood elevation (BFE), except where higher elevation is required by ASCE 24. Main equipment rooms located below grade must be provided with a hoist shaft for equipment removal and a stairwell for direct access. Electrical equipment located below grade must be provided with anti-desiccant strip heaters. Exterior openings such as stairwell, hoist shaft, drive, or loading dock must be protected from in-flow. Sump pump capacity must meet predicted precipitation events. Raceway exiting the building five foot line must be furnished with seals designed for the number and size of cables enclosed.

#### **11-5.4.3 Location of Electrical Rooms**

Pipes and other equipment foreign to the electrical equipment must not be located in, enter, or pass through such spaces or rooms. Mechanical and telecommunication rooms should not be located adjacent to electrical rooms due to the horizontal interference of ducts, piping, and trays. Rooms such as toilets or kitchenettes should not be located above electrical rooms due to the vertical interference of piping or ducting. Where practicable in finished areas, panelboards, signal, and communication cabinets must be grouped and surface-mounted in separate electrical and communication ventilated wiring rooms. Joint-use closets are not acceptable and must not be provided. Electrical rooms in which dry-type transformers and automatic transformer type regulators are installed should be located away from noise-sensitive areas and provided with adequate ventilation to maintain an ambient temperature not to exceed 86 degrees F. For MTFs with more than one floor, electrical rooms should be stacked vertically whenever practicable. Panelboards in Critical Care Areas must be located in the vicinity of their loads and must be accessible to the operating staff only. Such panelboards must not be located in the patient bedrooms. Electrical rooms must be located to minimize interference with patient care areas.

#### **11-5.4.4 Branch Equipment Rooms.**

A minimum of one branch equipment room must be provided for each smoke compartment of a hospital building space and each 22,500 square feet of other medical facilities building space. The footprint for each piece of equipment with working space and NFPA 70 clearance requirements must be shown. No branch equipment room must feed loads beyond the smoke compartment in which it is located. Branch equipment rooms must be accessed off of a primary through corridor, and the entry door(s) must swing out 180 degrees so as not to impede traffic flow in the corridor or violate clearance requirements of NFPA 70. Where approved by the design and construction agent, branch equipment rooms may consist of shallow rooms with fire doors utilizing the corridor for electrical clearance, in order to provide for the efficient use of building area. These rooms must not interfere with egress, by placement in or along egress routes. These rooms are only permissible if the corridor can be closed at any time for maintenance (due to arc flash hazard in which anyone entering area must wear protective gear).



### **11-5.5 Isolation Power Panel.**

Isolation power panels must be provided only for critical care spaces designated wet procedure locations by the Using Agency or NFPA 99. Flammable anesthetics are no longer used in the United States, but if their use is re-instituted isolation power panels would be required in these locations in accordance with NFPA 70. Locate isolation power panels and the line isolation monitor in the room served. Do not provide isolated power panels in labor and delivery rooms, as these rooms are not wet procedure locations (except provide in Operating Room, C-section, which is a wet procedure location).

### **11-5.6 Conduit, Cable Tray, and Wire.**

11-5.6.1 In this chapter, conduit and raceway conform to definitions in NFPA 70. All wiring must be insulated copper conductors in non-flexible metallic raceways installed in accordance with NFPA 70 and UFC 3-520-01. Run a green insulated copper ground conductor with all feeders and branch circuits. All single-phase circuits must have an independent neutral and a separate green insulated grounding conductor. In new construction, branch circuits must be uniformly sized from the branch circuit breaker to point of utilization, i.e. upsizing for voltage drop and employing junction box jumpers to make the utilization connection is prohibited. The use of metal-clad and armored cable is prohibited inside MTF's. PVC conduit may only be used below slab on grade in accordance with NFPA 70 and applicable UFCs, in which grade transitions are required to be metallic and usage in patient care areas is prohibited. Flexible metal conduit may only be used for light fixture tap conductors and where needed for equipment subject to vibration in accordance with NFPA 70 and applicable UFCs. These are only exceptions to non-flexible metallic raceway.

11-5.6.2 Each electrical room on each floor of multi-story MTF's must be served by separate or independent feeder risers of insulated copper conductor in steel conduit. The equipment serving the risers in these facilities must be located in ATS rooms for the essential electrical system and the main electrical equipment rooms for the normal power system.

11-5.6.3 Steel compression fittings must be used with electrical metallic tubing (EMT). Die-cast fittings must not be used.

11-5.6.4 Conductors installed to furnish emergency power must not be installed in the same raceway with normal power conductors.

11-5.6.5 All normal and emergency power junction boxes, pull boxes, and similar parts must be readily accessible. Clearly identified access panels must be installed as necessary for proper maintenance and operation of the electrical distribution system.

11-5.6.6 Low voltage control wiring, typically used for lighting and receptacle control, must be installed in non-flexible metallic raceway.

11-5.6.7 Horizontal telecommunication raceways, used in conjunction with cable tray between the outlet and telecommunication room, must terminate on the tray, with a fitting designed to connect the raceway to the tray.

11-5.6.8 Telecommunication room ground bars must be bonded in accordance with TIA-607 with ground conductors placed in raceway.

### **11-5.7 Branch Circuits.**

All circuits serving patient care areas must comply with NFPA 99 and NFPA 70, except where applicable criteria require more stringent standards.

### **11-5.8 Radiology Provisions.**

#### **11-5.8.1 X-Ray Rooms.**

Radiological equipment must be supplied by a 3-phase, 5 wire neutral and ground 480Y/277 V feeder from the main distribution switchboard to an enclosed circuit breaker disconnect located adjacent to the associated X-ray control room. X-ray loads must not be included in the demand load. Effect of X-ray unit momentary kVA load on transformer voltage regulation must be evaluated. Transformer size must be increased as necessary and feeders must be sized for satisfactory system performance. Separate service transformers to the X-ray units must not be provided. A single-phase 120/208 V branch circuit panelboard must be provided in each room for X-ray unit peripheral equipment. Additional requirements for Universal X-ray rooms are contained within Appendix D.

#### **11-5.8.2 Mobile X-Ray Unit Outlets.**

Mobile X-ray equipment in nursing units must normally be battery operated. Duplex receptacles rated 20 A, 125 V for battery recharging must be provided in designated areas and connected to the equipment system of the essential electrical system. Should battery-operated units not be used as determined by the Using Agency, each nursing unit corridor must be provided with a flush-mounted receptacle having these characteristics: 60 A, 250 V, 2-pole, 3-wire, single-phase, twist lock, grounding type.

### **11-5.9 Receptacles.**

Receptacles must be specification grade, heavy duty, normally straight blade type, rated 20 A, 125 V, 2-pole, 3-wire, grounded type. All other receptacles including those dedicated to medical equipment must not be of less than 20 A rating. General purpose multi outlet branch circuits serving receptacles must be rated 20A. Circuits serving desk locations (work stations) must have not more than four duplex receptacles and have a non-shared neutral. In other locations, including patient care spaces, circuits must have not more than six duplex receptacles, and more stringent requirements follow in the paragraphs below. Where a power receptacle is incorporated in the same metal box with a television or data outlet, a partitioned metal box with separate power and signal conduits must be provided as required. Outlets in adjoining room walls must be offset to isolate airborne sound as specified in Appendix B Architectural and Engineering

Design Requirements, and as required by the Fire and Smoke Protection Features chapter of the International Building Code (IBC). Furnish all 250 V receptacles with matching plugs.

#### **11-5.9.1 General Purpose Receptacles**

Provide a minimum of one duplex receptacle per wall in each room or interior area, except as noted below. Spacing must not exceed 12 feet. In rooms where partitions exceed 10 feet in length, provide an additional duplex for each additional 10 feet of wall space or fraction thereof. Provide minimum of one duplex within 1 foot of each telecommunication outlet. Provide two duplexes at each desk location (work station), including future desk locations in offices which have a second telecommunication outlet. Offices and examination rooms must have no less than six duplex. Provide one duplex every 3 linear feet of casework in nurse stations, nurse substations, reception counters, and control counters. Provide one duplex every 50 linear feet in corridor walls. Provide one duplex within 25 feet of installed equipment requiring maintenance. Do not provide receptacles in public toilets, staff toilets outside of command areas, closets, janitor closets, and scrub rooms. General purpose receptacles must be in addition to special purpose and dedicated outlets for special equipment. See Using Agency to identify requirements in special areas.

#### **11-5.9.2 Hospital-Grade Receptacles.**

Provide hospital-grade receptacles where required by NFPA 70 and where identified in the locations listed below.

- 11-5.9.2.1 General and Critical Care patient bed locations
- 11-5.9.2.2 Any location with either a patient bed or a patient care service console
- 11-5.9.2.3 Anesthetizing locations in:
  - a. Operating Rooms
  - b. Labor and Delivery Rooms
  - c. Oral Surgery
  - d. Cystoscopy (in Operating Rooms and clinics)
  - e. Cardiac Catheterization Lab
  - f. Angiography and Special Procedures
  - g. Computed Tomography (CT) Scanning Room
  - h. MRI Scanning Room
  - i. Medical Maintenance

- j. Intensive Care
- k. Emergency Trauma Rooms
- l. Fluoroscopy Rooms
- m. Endoscopy Rooms
- n. Pulmonary and Respiratory Therapy
- o. Nuclear Medicine

### **11-5.9.3 Electrical, Mechanical, and Telecommunication Rooms.**

Furnish electrical and mechanical rooms with at least one duplex receptacle from a dedicated circuit. Furnish telecommunication rooms with at least one duplex receptacle on each wall, at least one quad receptacle in each rack, and 30A-250V special purpose receptacles for rack mounted power supplies. Circuits supplying receptacles in telecommunication rooms must originate from limited access panels, be dedicated to a single telecommunication room, and must comply with essential branch circuiting specified in Chapter 12 Communications. In telecommunication rooms, wall mounted receptacles are usually normal power; and where more than one (normal or essential) branch is required on each wall or rack, adjust the number of receptacles accordingly.

### **11-5.9.4 Tamper-resistant Receptacles.**

Tamper-resistant receptacles must be provided in locations required by NFPA 70 and 99. They must be provided in all areas where children may be present and not under constant adult supervision. Within pediatrics, they must be provided in patient rooms, bathrooms, playrooms, activity rooms, offices, corridors, waiting rooms, and exam rooms. They must also be provided in other areas of the MTF designated out-patient, in offices, corridors, and waiting rooms. The tamper resistant receptacles used in these areas must be designed to prevent shock hazards from metallic objects that might be inserted in the receptacle slots. Tamper-resistant receptacle covers must not be used. Tamper-resistant receptacles must be provided in behavior health in accordance with Appendix A Behavioral Health Design. Circuits serving receptacles in behavior health in-patient rooms must be dedicated to the room in which the receptacle is located, protected by a Class "A" GFCI breaker (as an exception), and controlled by a single switch outside the room under staff control.

### **11-5.9.5 Ground Fault Circuit Interrupters (GFCI).**

Provide Class "A" GFCI receptacle protection in wet locations and where required by NFPA 70. See Paragraph 11-2.2 for definition of wet locations and wet procedure locations. GFCI must not be provided on circuits serving critical life support equipment where interruption of power could cause injury or death, e.g., wet procedure locations in Operating Rooms. GFCI breakers are not permitted, except as noted. Wet locations include the following

- a. Hydrotherapy
- b. Therapeutic pool areas
- c. Patient toilet areas with or without showers
- d. Staff lockers with toilet or shower areas
- e. Staff lounge with kitchen facilities
- f. Outdoor receptacles
- g. Other locations required by NFPA 99 and NFPA 70
- h. Receptacles accessible from a building roof
- i. Crawl spaces

#### **11-5.9.6 Patient Bedrooms.**

Provide Critical Care patient bed locations (patient headwalls) with a minimum of fourteen duplex receptacles. Provide general care patient bed locations (patient headwall) with a minimum of eight duplex receptacles. No more than two duplex receptacles must be connected to a separate 20 A, 125 V circuit in Critical Care patient bed locations.

#### **11-5.9.7 Renal Dialysis Units.**

Within renal dialysis units, provide four hospital-grade duplex receptacles on each side of the patient bed or lounge chair. Provide normal and critical branch power.

#### **11-5.9.8 Nurseries.**

Each Intensive Care Nursery must be provided with 16 simplex receptacles. Each Intermediate Care Nursery must be provided with eight simplex receptacles. Each Nursery in Admission, Observation, and Continuing Care must be provided with four simplex receptacles. Normal Care Nurseries must be provided with one simplex receptacle. Receptacles must be 20 A, 125 V, 2-pole, 3-wire, straight blade, grounded type. Floor-mounted receptacles must not be used. Ceiling-mounted receptacles or groups of receptacles should be considered for Nursery locations not adjacent to a wall or column. A minimum of one flush-mounted receptacle for mobile fluoroscopy units must be provided in each Nursery, with these characteristics: 60 A, 250 V, 2-pole, 3-wire, twist lock, grounded type.

#### **11-5.9.9 Operating Rooms.**

Provide each Operating Room with a minimum of 36 duplex receptacles and not less than 6 hospital-grade duplex receptacles on each wall mounted 3 feet above the floor. Not more than two duplex receptacles must be connected to a 20 A, 125 V circuit. Each

service column must have not less than 16 hospital-grade simplex or 8 hospital-grade duplex receptacles with not more than 2 simplex or 1 duplex receptacle connected to a 20 A, 125 V circuit. Each breaker must be switch class rated, and each receptacle must be 20 A, 125 V, 2-pole, 3-wire, straight blade, grounded type. Each Operating Room must also be provided with one 60 A, 250 V, 2-pole, 3-wire, twist lock, grounded-type, flush-mounted receptacle for a mobile fluoroscopy unit or laser photo coagulator. Arrange the 20A 125 volt duplex wall receptacles such that adjacent receptacles are served from a different isolation power panel and equally divide the patient service column receptacles circuits between isolation power panels.

#### **11-5.9.10 Laboratory Receptacles.**

Above laboratory benches, duplex receptacles must be strip-mounted 18 inches or less on center. Adjacent duplex receptacles must be connected to different circuits and not more than four duplex receptacles must be connected to each circuit. Where benches are provided by others, provide circuit breaker(s) and raceway to connection point, for pulling of conductors by the IO&T Contractor.

#### **11-5.9.11 Examination and Treatment.**

Examination and treatment rooms must have no less than 8 duplex receptacles. Category 2, treatment rooms as defined in Appendix B Architectural and Engineering Design Requirements must have hospital-grade receptacles and be supplied by not less than two separate and independent critical circuits; except no less than one critical and one normal circuit, where facility is allowed a single transfer switch by NFPA 70.

#### **11-5.9.12 Automatic Receptacle Control.**

Provide automatic receptacle control in accordance with ASHRAE 90.1 in administrative spaces to include work stations, offices, conference rooms, classrooms, and break rooms. Automatic control must not be provided in any area which may endanger the health, safety, or security of patients, staff, or visitors; such as examination, diagnosis, treatment, laboratory, nurse stations, patient care, emergency department, or utility. Receptacles must be split circuit type (half-controlled). Control system must be hard wired and not rely upon flexible cords.

#### **11-5.10 Receptacle Identification.**

Receptacles connected to the life safety, critical, and equipment branches must have red bodies to identify essential power and the device plate must be marked "EMERGENCY". All receptacles, normal and essential, must also have the panelboard and circuit number identified on the device plate. Marking of device plates must be with steel stamped or silk-screened letters, by laminated plastic nameplates with contracting color center core, or by embossed aluminum or stainless steel tape. Letters must be not less than ¼-inch high. Pressure sensitive or thermal tapes must not be used. In behavioral health, pediatrics, and other areas where it is necessary to protect against the label being removed and ingested, silk screened letters must be used.

### **11-5.11 Patient Care Grounding.**

General care areas and Critical Care Areas including all anesthetizing locations must be provided with a grounding system as required by NFPA 99 and NFPA 70. Grounding system design and initial testing must be included in the contract documents.

### **11-5.12 Inhalation Anesthetizing Location.**

All inhalation anesthetizing locations must be classified and designed as a nonflammable inhalation anesthetizing location. Isolated power panels must be provided for areas designated as Critical Care wet procedure locations by the Using Agency. GFCIs must not be provided. Design must conform to the requirements of NFPA 70 and NFPA 99. Provide each Operating Room with two single-phase panelboards located within the room. Each panel must be fed from a separate critical branch subpanel that is served from separate critical branch ATs. Panels must be connected to the same phase. Grounding in inhalation anesthetizing locations must be in accordance with 11-5.25, Patient Care Grounding.

### **11-5.13 Electromagnetic Shielding for Medical Instrumentation.**

Designated areas of hospitals and health research laboratories may require electromagnetically shielded enclosures. The degree of the attenuation required for the enclosure must be based on the manufacturer's recommendation for the instrumentation to be used in the designated space. Shielded enclosures must conform to the requirements of MIL-E-8881. Final design must specify the type of enclosure and the class of attenuation required. When shielded enclosures are not provided, take other measures to limit RFI and EMI in rooms that contain sensitive medical equipment, e.g., electroencephalography (EEG), Eye LASIK and electron microscope rooms. For example, select lighting in which the ballast does not emit electromagnetic radiation. Such rooms must not be located near or directly above or below electrical equipment or mechanical rooms. High-voltage feeders must not be routed in the vicinity of these rooms.

## **11-6 LIGHTING.**

### **11-6.1 Design.**

#### **11-6.1.1 General.**

Design lighting in accordance with Appendix B Architectural and Engineering Design Requirements, Illuminating Engineering Society North America (IESNA) Lighting Handbook, and ANSI/IESNA RP-29-16. This UFC governs where conflicts exist. Electronic ballasts and drivers in MTF's must not generate electromagnetic fields or radio frequencies that interfere with life support equipment, patient implant life support devices (e.g. pacemakers, heart monitors) and must be electromagnetically compatible with the operating environment. For the intent of this section, lighting is designated general illumination, task illumination, and task focus illumination. General and task illumination are generally in-ceiling mounted and maintained illumination levels meet criteria specified in Appendix B Architectural and Engineering Design Requirements

within plus or minus 10 percent. Task focus illumination is generally provided as FF&E and is not accounted for in Appendix B Architectural and Engineering Design Requirements levels.

#### **11-6.1.2 Control.**

Provide lighting controls in accordance with UFC 3-530-01 and Appendix B Architectural and Engineering Design Requirements subject to the functional and operational intent of the MTF. In no instance must automatic control be provided in a manner which could endanger the health, safety, or security of patients, visitors, or staff. Do not use time-scheduled controls in patient care or utility spaces. Provide override devices where automatic controls are installed and where occupancy/vacancy controls are used, they must be dual technology type. Do not use occupancy/vacancy controls in treatment or utility rooms, as turning lights off in these areas could create a safety hazard. Where day lighting strategies are employed for energy conservation, accomplish de-lighting with automatic lighting controls utilizing photo sensors to provide continuous dimming of the electric lighting system. Do not use de-lighting in patient care rooms and areas. Where Appendix B Architectural and Engineering Design Requirements lighting controls result in general illumination levels which exceed the allowable lighting power density, provide individual control of lamps/arrays within fixtures, to split illumination into an allowable general level and a separate task level, to meet applicable exemptions.

#### **11-6.1.3 Sources.**

Provide fluorescent or light emitting diode (LED) lighting to the maximum amount practicable. Projects must use either all fluorescent or all LED luminaires. An exception is allowed to mix sources for violet fraction, as described in paragraph Dental Clinic, and also for low level luminaires which have a negligible contribution to overall illumination and color variation, such as exit sign, information sign, step, night, task focus, and accent lighting. For exterior lighting see paragraph 11-6.8. Recessed luminaires must be provided in rooms with lay-in acoustical tile ceilings and recessed or surface-mounted luminaires in rooms with gypsum board on plaster ceilings, except where other types are required by the functional design. Generally use industrial type or open strip type luminaires in rooms with unfinished ceilings and protect each from breakage. Luminaires in large storage and supply rooms must be mounted to readily permit relocation within several feet. Tandem wiring, where ballasts or drivers in one luminaire supply lamps or arrays in another, is not permitted. In unconditioned buildings or spaces, specify a luminaire that has been UL listed for 60 degree C or above. Use of high intensity discharge (HID) lamps in patient care areas is not permitted. "U" shaped fluorescent lamps are not permitted. Tubular LED (TLED) lamps are not permitted. The fluorescent lighting system baseline energy efficiency must be based on the use of 28 watt T5 and 32 watt T8 lamps. LED luminaires must be provided with a 5-year warranty by the manufacturer must. Minimize types of luminaires and lighting sources as far as practical to simplify operation and maintenance.



#### 11-6.1.4 Color.

The same color requirements apply to fluorescent and LED sources. Provide 4000 degree K correlated color temperature (CCT) through the facility. This single CCT is used to maintain consistency and to coordinate with task focus lighting.

##### 11-6.1.4.1 Chromaticity.

Chromaticity of lighting products must fall within an ANSI C78.377-2015 4-step quadrangle centered at 4000K. Chromaticity for different units in the production must be enclosed by a 3-step MacAdam ellipse. Compliance is to be verified by the manufacturer or an independent photometric testing laboratory with a minimum test size of 10 units, and warranted by the manufacturer. The chromaticity of every unit in the test sample must be contained in the ANSI 4-step quadrangle. The entirety of the MacAdam ellipse, centered at the mean chromaticity of the samples, need not be fully contained in the 4-step quadrangle. For all units in the test sample, change in chromaticity from the zero-hour measurement to the 6000 measurement hours must be within a total linear distance of 0.003 on the CIE 1976 UCS ( $u'$ ,  $v'$ ) chromaticity diagram. All interior lighting products must meet the following performance criteria, which are based on IES TM-30. The light source spectral power distribution (SPD) and the IES TM-30 color vector graphic are required submittals.

- a. Fidelity Index:  $R_f \geq 80$ ,
- b. Relative Gamut Index:  $97 \leq R_g \leq 110$ ,
- c. Fidelity Index, Hue-Bin 1:  $R_{f,h1} \geq 78$ ,
- d. Chroma Shift, Hue-Bin 1:  $-9\% \leq R_{cs,h1} \leq +9\%$ .

##### 11-6.1.4.2 Violet Fraction.

In areas defined in Appendix B Architectural and Engineering Design Requirements, and as described in paragraph Dental Clinic, where color matching is a critical function, the violet fraction for LED general lighting products must be between 4% and 6%, where violet fraction is computed as the optical radiation from 360 to 430 nm divided by the optical radiation from 360 to 830 nm. This criterion is in addition to the criteria for chromaticity, CCT, color shift, and color rendition.

$$\text{Violet fraction (\%)} = \frac{\text{Optical radiation from 360 to 430 nm}}{\text{Optical radiation from 360 to 830 nm}} \times 100$$

##### 11-6.1.4.3 Exceptions.

The following exceptions are allowed during the transitional period for industry to adapt, produce, and document a variety of products meeting the TM-30 metrics. Exceptions only apply if products from 3 manufacturers are not readily available meeting TM-30 metrics. There is no exception for violet fraction. The TM-30 metrics are fidelity index,

gamut index, hue-bin one fidelity, and hue-bin one chroma shift. All other lighting requirements specified herein must also be met.

- a. Exception No. 1, Decorative Lighting: Decorative lighting, as defined in ASHRAE 90.1, is not required to meet the gamut index and hue-bin one metrics; but is required to meet the fidelity index. If fidelity index products are unavailable; CRI 80 or greater will be considered an acceptable alternative.
- b. Exception No. 2, Unusual Location: Architectural focal points and utility spaces are not required to meet the gamut index and hue-bin one metrics; but are required to meet the fidelity index. If fidelity index products are unavailable; CRI 80 or greater will be considered an acceptable alternative. Architectural focal points are defined as entry and atrium (but not to include patient waiting). Utility spaces are mechanical and electrical rooms, elevator pits, tunnels, etc.
- c. Exception No. 3, LED Luminaires: If TM-30 metric products are unavailable, CRI 90 or greater LED luminaires will be considered an acceptable alternative to the fidelity index, gamut index, and hue-bin one metrics.
- d. Exception No. 4, Fluorescent Lamps: If TM-30 metric products are unavailable, CRI 85 or greater lamps will be considered an acceptable alternative to the fidelity index, gamut index, hue-bin one metrics, color consistency, and color shift; except CRI 90 lamps must be provided where indicated in Appendix B Architectural and Engineering Design Requirements.

#### **11-6.1.4.4 Submittals.**

See Annex D, Luminaire Design Review Checklist, for a list of factors which must be confirmed, through catalog cuts and manufacturer letters, in both the design and construction phases. Annex D is not all inclusive and is intended to be used in conjunction with the UFGS. TM-30 submittal data will not be required for the metric for which an exception above applies.

#### **11-6.1.4.5 UFGS Coordination.**

The UFGS must be modified to accommodate the minimum requirements contained herein. After the transitional period the UFGS and other criterion will be updated.

#### **11-6.1.5 Glare.**

LED lighting must be indirect or utilize a refractor. Shield LED light sources in the luminaires with physical separation or lenses to avoid a direct view of light sources and the resultant glare. Avoid placing non-exam lighting directly over a location where a patient lying supine or angled in a bed or gurney will be. LED designs must consider illuminance of the point source, in relationship to the ambient background, and eliminate

glare though higher mounting heights or using more luminaires at lower lumens. Luminaires utilizing T5HO lamps must not be mounted below 8 feet- 6 inches unless specifically designed to control brightness.

#### **11-6.1.6 Flicker.**

LED fixtures must comply with IEEE 1789-2015. Specifically, the maximum percent flicker must be less than or equal to the flicker frequency x 0.08. Dimmable LED products must comply at full output and throughout the dimming range.

#### **11-6.1.7 Nameplates.**

Identify luminaire driver/array/lamp replacement by an appropriate marking on the fixture reflector. Marking should indicate replacement with the original equipment by name only and should not be visible through the fixture lens.

#### **11-6.1.8 Life.**

LED luminaires must have a minimum L70 lumen maintenance value of 60,000 hours.

#### **11-6.1.9 Illumination of means of egress**

Illumination of means of egress, in both the normal and emergency modes of operation, must be provided in accordance with NFPA 101. The minimum NFPA 101 egress illumination must be on at all times the building is occupied and switched by a switch class circuit breaker, with higher illumination level(s) motion controlled, as required by UFC 3-530-01. Hallways adjacent to sleeping rooms and nursing stations are an exception, in which the higher illumination level(s) must be manually switched. All electrical, mechanical, and telecommunication rooms must have emergency lighting.

#### **11-6.2 Battery-Operated Lighting.**

Provide 25 percent of the general and task lighting in the Operating Rooms, emergency treatment rooms, cystoscopy, cardiac catheterization rooms, and any other room with invasive procedures with 1½-hour battery backup for general ceiling-mounted luminaires that provide general or task illumination that operates without interruption during periods of normal and emergency power lapse. These luminaires must be fully illuminated when on battery backup or UPS and provide not less than 500 lux of maintained illumination measured at floor level in the room. All permanently installed surgical task focus luminaires must be provided with a minimum of 1½ hours of no-break power to bridge the power interruption due to loss of normal power or essential electrical system failure. Locate batteries for lights in Operating Rooms outside those rooms. Provide 15 percent of lighting in nurseries with 1½-hour battery backup. Provide a minimum of two battery-powered lights in each generator set location and emergency switchboard location and central Communications Room. Provide a battery-powered light above each blood draw station unless lighting is connected to essential power.

### 11-6.3 Patient Bedrooms.

In patient bedrooms, one wall-mounted direct or indirect, or ceiling mounted indirect luminaire or a medical wall module system, with lighting features as described herein, must be provided at each bed for task (reading) and general illumination. Each wall unit must provide upward directed light for general illumination and downward light for patient use. Each ceiling unit must have separate general and patient use illumination. The general illumination must be controlled at the door and at the wall unit with a three-way switch. The patient's use lighting must be switched at the bed. All switches must be quiet-operating. Use of low-voltage switching utilizing the NC handset must be considered. Night-lights mounted in the patient service console must be provided at each bed and must be photo cell controlled and manually controlled at the corridor door. The additional task (exam) luminaire located over the patient bed must be switched at the patient head wall.

### 11-6.4 Other Rooms.

11-6.4.1 Luminaires in nurseries, surgery, obstetrical suites, emergency treatment rooms, examination rooms, and laboratories must be recessed type. Nurse station lights must be switch controlled to achieve 33 percent, 66 percent, and 100 percent illumination levels for fluorescent and full range dimming for LED. Corridor lights adjacent to Intensive Care bedrooms and nursing units must be one-third increment switch controlled for fluorescent and full range dimming for LED. In recovery rooms, coronary and ICUs, and X-ray therapy rooms where patients may be in a supine position for extended periods, low-brightness diffused lighting must be provided. Where indirect sources are not feasible or not desirable, locate luminaires outside of direct view of patients. X-ray rooms must be provided with indirect lighting; in other radiographic procedures, the location of room lights must be coordinated with X-ray equipment. Electroencephalogram rooms must be provided with dimmable luminaires. For examination purposes in ICUs, isolation rooms, single patient bedrooms, labor rooms, and recovery, an exam luminaire operated by a conveniently located switch must be provided above each bed.

11-6.4.2 Lighting in behavioral health unit must comply with Appendix A Behavioral Health Design. Fixtures, including night lights, must be recessed, anti-ligature, of tamperproof construction, with impact-resistant lenses. Control night lights with a photocell, with a manual switch outside the room.

11-6.4.3 "In-Use" warning lights must be provided for Universal X-ray rooms and Therapeutic X-ray rooms in accordance with Appendix D. Diagnostic X-ray rooms must not be provided with "In-Use" lights. Refer to Chapter 16 Medical and Dental Equipment for more details.

11-6.4.4 In-ceiling, surgical task focus lights, must be provided in Labor and Delivery Rooms. The task focus lights must be contractor furnished, contractor installed, and provided with a remote station to directionally control the luminaires. The color characteristics of the task focus lights must match general illumination.

### **11-6.5 Dental Clinic.**

Ceiling-mounted luminaires must be symmetrically arranged within all finished areas except open dental operatories. In such operatories, concentrate luminaires on both sides of the dental chairs. Lighting intensities at the working surface in each dental operatorie must be not less than Appendix B Architectural and Engineering Design Requirements levels and controlled by full range dimming (in the event a dimmers fail, the lights must default to full intensity and the switches function as an on/off switch).

11-6.5.1 In areas such as prosthetics laboratory and DTR's, that involve the visual matching of human teeth to resins, crowns, veneers, or other restorations; the violet fraction for general illumination must be as specified in paragraph, "Violet Fraction." Violet fraction is generically met with fluorescent sources, therefore this requirement only applies to LED sources.

11-6.5.2 Currently, limited LED products are available which meet the violet fraction requirement. Therefore if LED lighting is a project requirement, a sole source waiver for LED luminaires in dental areas, should be approved by the Contracting Office in the Geographic District, before commencing design. However if the waiver is not sought and fluorescent lighting is used in dental areas instead, as an exception, the remainder of the project may still be LED.

### **11-6.6 Eye LASIK/PRK Rooms.**

Ceiling-mounted luminaires in Eye LASIK/PRK rooms must be fully dimmable and ballast or driver filters must be integral into the shielded luminaire assembly with one filter per ballast or driver and must suppress/eliminate electromagnetic interference and radio frequency interference with the LASIK equipment. Support the power for the LASIK equipment and lighting in each room by an UPS that provides a minimum of one and a half hours of no-break-power in addition to the essential electrical system power provided by the critical branch. Provide an "In-Use" warning light outside each Eye LASIK/PRK room.

### **11-6.7 Exterior Signage.**

Exterior signage for "EMERGENCY SERVICES" must be stencil-faced with red trans illuminated letters, and must be readily visible, identifiable, and legible at all entrance drives. The contrast level of illuminated signage must be symmetrical and not deviate more than  $\pm 5$  percent. Signage for facilities having after-dark operations must have trans illuminated letters indicating the facility name. Illuminated signs must be designed for rapid replacement (time not to exceed 15 minutes). Sign location must be coordinated with illumination of access roads, parking areas, and building entrances to minimize requirements for additional illumination of signage.

### **11-6.8 Exterior Lighting.**

Provide exterior lighting for safety of patients, visitors, and staff; and for operation and maintenance. Parking areas and walks, including accessible areas intended for night use, must be illuminated to an average of no less than 10 lux (1 foot-candle), measured

on 1 foot intervals of incident light on the area served. Other areas, including roadways and utility areas, must be illuminated in accordance with the recommendations of IES and UFC 3-530-01, following the more stringent requirement. Light sources must conform to UFC 3-530-01 and may be fluorescent, induction, metal halide, or LED; they must have a CCT not less than 3000 or more than 4000 degree K, and a CRI not less than 70. The LED product's lumen maintenance life, L70, must be equal to or greater than 50,000 hours. Design lighting to eliminate glare and trespass between site-structure-surround; by complying with IES International Dark Sky Association Model Lighting Ordinance (MLO) lighting zones and backlight-uplight-glare (BUG) ratings; and by complying with ASHRAE 90.1 lighting power density (LPD).

#### **11-6.9 Dimming.**

Furnish eye lane, eye examination and eye LASIK/PRK rooms, and group therapy observation room illumination with recessed and full range dimmable luminaires. Switches and dimmers for eye lanes and eye examination rooms must be located close to the examination chair. Maximum foot-candle level in group therapy observation rooms with respect to foot-candle level in group therapy (mirror) rooms should not exceed manufacturer's recommended ratio for one-way mirrors utilized. General lighting in fluoroscopic and radiographic special procedures rooms must be dimmed at the control stand or at the door entrance, as required (in the event a dimmer fail, the lights must default to full intensity and the switches function as an on/off switch).

#### **11-6.10 Ultraviolet (UV) Filters.**

UV filters must be provided for fluorescent lighting in infant care areas to prevent retina damage to premature infants, and other areas where cataracts are a major concern. Indirect lighting in premature infant areas must be provided for all new construction.

#### **11-6.11 Maintenance Area Lighting.**

Interior utility tunnels and walk-in pipe chases must be illuminated by one foot-candle of incident light for the safety of maintenance personnel. Switches for these lights must be equipped with pilot lights and located in areas that are normally occupied. Elevator shafts must be illuminated in accordance with UFC 3-490-06. Receptacles for temporary work lights must be located as determined by the Design and Construction Agent.

#### **11-6.12 Auditorium.**

The down light luminaire over the podium must be controlled from the podium and the entrance.

#### **11-6.13 Continuity of Service**

Provide spares in the initial procurement to insure color matching. The design for the lighting system serving critical care spaces must include, for each luminaire served from either the essential or emergency branch within a facility, including battery backup

luminaires not connected to the branch, a 5 percent stock of replacement matching LED arrays and pre-programmed LED drivers, with a minimum of one per fixture type.

**11-6.14 Accessibility**

Provide maintenance access to luminaires by placing them where they can be reached, by the use of lowering devices, or by built-in access provisions such as catwalks or trolleys. Where specialized equipment is required, it must be supplied with the fixture and adjacent storage built in. Only step ladders may be considered for portable ladders and height is limited to 20 feet by OSHA. Moveable machinery such as scissor lifts must not be considered as meeting this requirement.

**11-7 HELIPAD LIGHTING, MARKING, AND CONTROLS.**

Helipad marking, lighting, and controls must be in accordance with UFC 3-535-01 and UFC 3-535-02. Facilities must be provided for hospital configuration, visual meteorological conditions (VMC), non-instrument, to include those listed in Table 11-3. Provide retro-reflective markings per UFC 3-535-02. Lighting must be locally controlled at helipad, remotely controlled within medical facility, and radio controlled by pilot. See Annex A for Radio Control Operation. The visual glide slope indicator must be a 2-box Chase Helicopter Approach Path Indicator (CHAPI). Provide the usual CHAPI glide slope angle of six degrees unless a steeper glide slope is needed to avoid obstacles. If required, provide a waiver request to UFC 3-535-01.

**Table 11-3 Medical Helipad Visual Facilities Requirements**

Facility	VMC Day Non-Instrument	VMC Night Non-Instrument	Remarks
Perimeter Lights	NA	R	
Wing Lights	NA	R	
Landing Direction Lights	NA	OPT	
Approach Direction Lights	NA	OPT	
Helipad Floodlights	NA	R	
Visual Glide Slope Indicator	OPT	R	
Helipad Beacon	R	R	
Wind Direction Indicator	R	R	Provide obstruction light and illuminate sock
Retro-reflective Marking	R	R	
Local and Remote Control	R	R	
Essential Power	R	R	

Legend: NA=Not-applicable, OPT=Optional, R=required

**11-8 LIGHTNING PROTECTION.**

Provide lightning protection in accordance with UFC 3-575-01. Provide a risk assessment in accordance with NFPA 780. If protection is recommended by the assessment, a system must be provided. The system must be in accordance with NFPA 780 and use components meeting UL. Provide a UL Lightning Protection Inspection Certificate certified to NFPA 780 upon completion. A UL listed installer is required in the construction phase in order to obtain the UL inspection certificate; which must be clarified in bid documents, and for OCONUS locations list three Contractors. For additions to existing facilities with a lightning protection system, the existing system must be recertified before the new portion can be connected to the existing lightning protection system.

CANCELLED



### Annex A. Hospital Helipad Radio Control Operation

The radio controller must be in accordance with AC150/5345-49C and function as noted here:

- a. The pilot can activate the hospital helipad lighting by keying the microphone from the helicopter after tuning to the assigned frequency.
- b. The pilot can key his microphone three times within a 5-second interval and on the third pulse a relay is energized, which turns on the wind indicator illumination, CHAPI, and the perimeter light pattern.
- c. The floodlights can be activated by keying the microphone five times.
- d. The light must remain on until the pilot keys his microphone seven times. This must activate the turn off time delay relay, which de-energize the lights at the end of the 15 minute delay.
- e. When the lights have been activated by the radio controller, the "OFF" function of the remote "ON-OFF" switch in the manual controller, located in the hospital Emergency Room (ER), must be bypassed.
- f. The brightness of the CHAPI, floodlights, and perimeter lights can only be controlled from the manual control panel in the ER.
- g. If the microphone has been keyed seven times (floodlight turn off signal), the radio controller can be reset by keying the microphone three or five times.
- h. The hospital ER must be equipped with the manual controller and a base radio station to be capable of manual or radio operations.

## Annex B. Multi-Ended Network Substation

### 1. GENERAL.

The multi-ended network (fully automatic) substation (Figure 11-2) design philosophy eliminates many switching time delays; simplifies the monitor and control functions; standardized equipment; reduces equipment size; provides expansion capability for future load growth; and maintains reliability, durability, and maintainability. When using the multi-ended network or the double-ended substation to replace an existing substation, all downstream equipment requires short circuit current validation and power system coordination.

### 2. NORMAL HOSPITAL SOURCE ALTERNATE DESIGN CONFIGURATION.

For electrical design criteria related to power supply, see documents listed in Appendix J References. Hospitals must be served by two primary service feeders, each connected to one side of the automatic (with alternate manual operator) load break primary selector switch with manual load break BP/ISs that serves a multi-ended network substation. Each feeder must have the capacity to serve the full hospital demand plus 20 percent spare load growth, and must be installed underground within the hospital site. The primary selector switch with BP/ISs must have the capacity to serve not less than the sum of the three transformer's kVA rating, and have load limiting equal to the full hospital demand plus the 20 percent spare load growth. The automatic function must monitor both primary feeders, and if power is lost to the feeder serving the load, the load must be transferred to the other feeder in not more than 30 cycles if power exists on that primary feeder. Service feeders must be connected to different power sources, if available, and to two differently routed distribution system feeders. Where two power sources are not available, the service feeders may be connected to two different sections of a true loop system.

Transformers must normally be located outside the hospital, but may be located within the building where practicable and economical. Multi-ended network substation distribution systems must be designed for hospitals, medical centers, and specially designated facilities. Each transformer in the multi-ended network transformer substation must be sized to carry 50 percent of the full hospital demand and spare load (linear and nonlinear) growth capacity. All transformers must be identical and impedance matched. All multi-ended network transformer substations must have coordinated surge and fault protection. The system protection must be selective. The main feeder panel bus capacity must not be less than the sum of the transformer capacity.

### 3. AUTOMATIC PRIMARY FEEDER SELECTOR SWITCHES (APFSS).

The APFSS (*not to be construed as an ATS*) may be double-throw with draw-out construction. The APFSS rating must be not less than the sum of the three transformer kVA ratings, and have adjustable load or fixed limiting control (the loading control may limit the capacity to that of two transformers). Contacts may have viewing ports for ease of contact inspection. The APFSS must have indicator lights to identify which normal primary feeder is connected to the load (green in color). Load transfer to either

normal primary feeder must be achieved with not more than 30 cycles of load interruption. All APFSS must be equipped with a load break BP/IS to maintain normal primary service feeder connection or when the APFSS is being repaired or maintained. The BP/IS can be initiated with not more than two movements of the hand to either position regardless of the position or condition of the APFSS. Two vacuum power circuit breakers with load break BP/IS may be used.

4. **TRANSFORMERS.**

- a. Each service entrance transformer of the multi-ended substation with fans is sized to carry 40 percent of the design load as to utilize standard off-the-shelf units and increase transformer efficiency. Each of the three transformers are equipped with forced air-cooling fans to increase the continuous capacity rating of each transformer by 34–50 percent of the design load when activated. The fans are automatically activated when the load on any transformer exceeds the no fan rating. The temperature indicator and the current relay must activate the cooling fans. If the fans are not activated when the temperature indicator or the current relay exceed the manufacturer's setting, alarms must be sounded so load shedding can be initiated. Each transformer must carry a 10 percent overload for short periods of time without fans.
- b. If a service entrance transformer fails, is offline for maintenance, or the normal bus receives no power from any one of the service entrance transformer feeders, the fans on the remaining two service entrance transformers must be automatically activated allowing 100 percent of the total hospital load to be assumed. There is no time delay in the load shifting to the remaining two transformers.
- c. Where each transformer of the multi-ended network substation is sized for no fan application, each transformer must be sized to carry not less than 50 percent of the full hospital demand and spare load (linear and nonlinear) growth capacity. Each transformer feeder serving the normal bus must be equipped with an alarm to indicate power loss from that feeder to the normal bus.
- d. The transformers in the multi-ended network substation must be identical and impedance matched.

5. **52 DEVICES.**

The 52 devices (AC power circuit breaker devices, draw-out type) must be sized to support the transformer capacity.

- a. The equipment must be laid out in a manner that allows load center expansion without requiring replacement. New sections can be added to either end of the load center.

- b. The main load center bus must be sized for not less than the sum of the three transformer kVA rating.

6. **GROUND FAULT.**

Ground fault protection for Military Medical Facilities must conform to those requirements in NFPA 70, NFPA 99, and this document.

7. **STANDARDS.**

All metering must read true RMS, and the protective relays and devices must comply with Institute of Electrical and Electronics Engineers (IEEE) standards.

CANCELLED

Figure 11-2 Multi-Ended Network Substation System Diagram

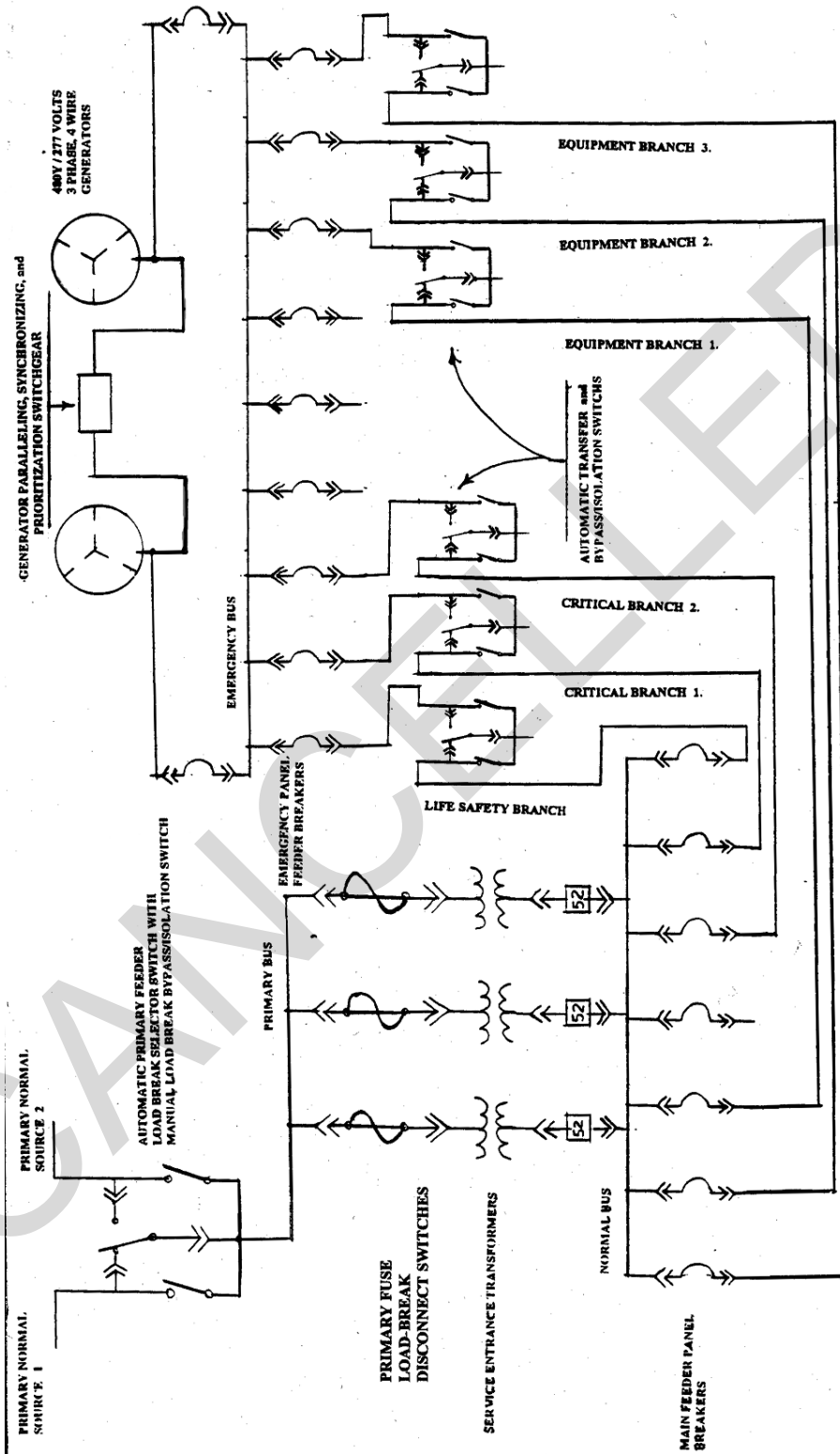

### **Annex C. Expandable Dual-Ended Substation with Simplified Alternate Power Source Configuration**

See Figure 11-3 for Expandable Dual-Ended Substation and the following requirements:

1. The bus for the substation must be sized for the total substation capacity at 100 percent demand.
2. Generators “1” and “2” do not operate in parallel with each other or the normal power source (utility), but are separate and independent.
3. The normal power side of the ATSS must be the default position when power is available and when there is no normal or alternate power available.
4. Generator “1” is sized to support all loads that cannot be shed plus 20 percent future load growth at 100 percent demand.
5. Generator “2” is sized to support all sheddable equipment loads of the essential electrical system, non-essential loads plus 20 percent future load growth at 100 percent, or the loads addressed in item “4” here, whichever is greater.
6. The load shed controls must shed the lowest priority loads (first) on generator “2” when ATS 2-A, 2-B, and 2-LS are transferred to generator “2.” The AC equipment for non-delayed automatic connection are non-sheddable loads.
7. BP/IS must be 4-pole, double-throw construction with normal power, open, and emergency power positions.

Figure 11-3 Expandable Dual-Ended Substation

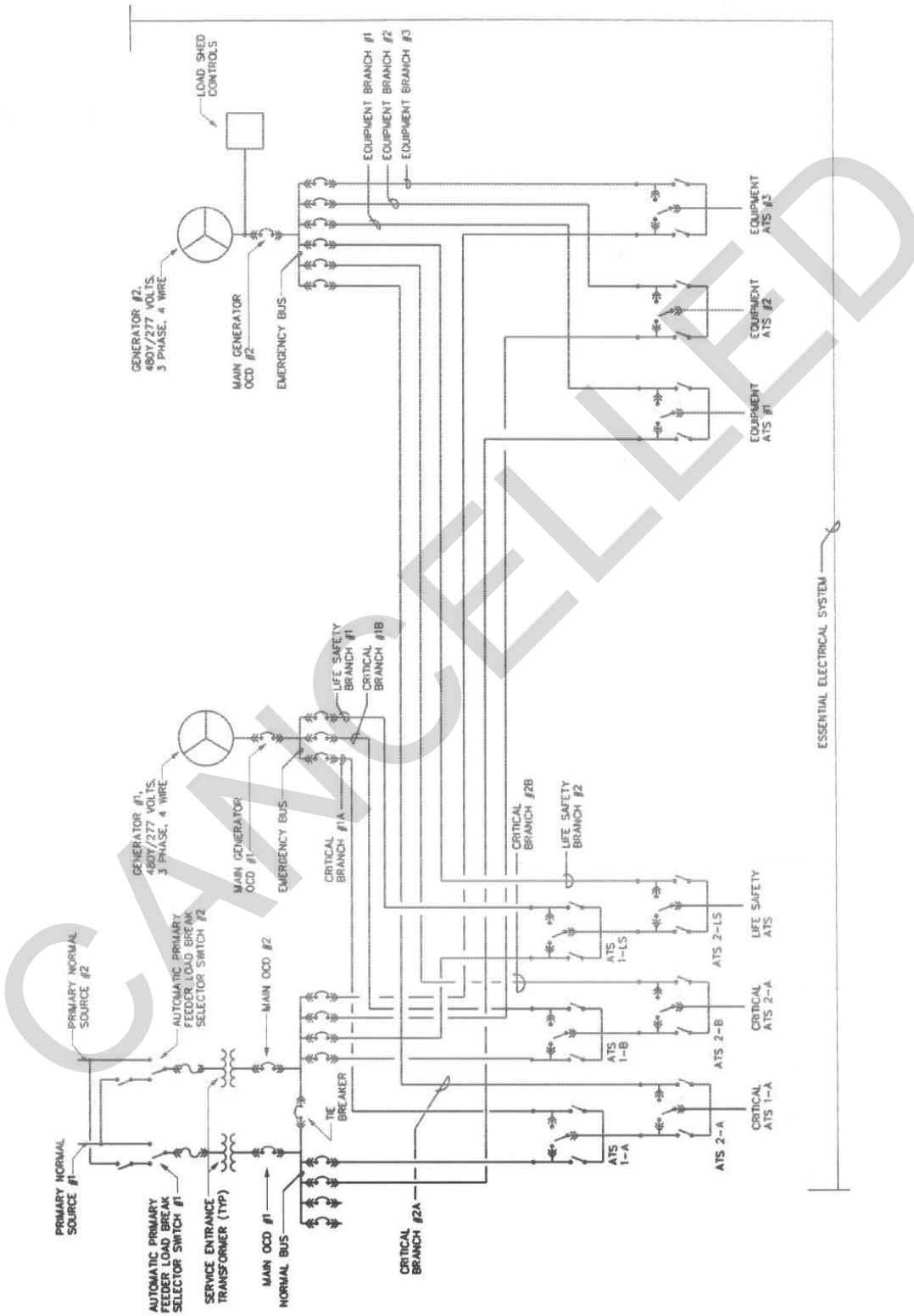

## Annex D. Luminaire Design Review Check List

General. The factors below, as applicable to the design, must be confirmed through catalog cuts and manufacturer letters, in both design and construction phases. This list is not all inclusive and is intended to be used in conjunction with the UFGS.

**Table D-1 Luminaire Factors**

- Color Consistency: Within a 3-step MacAdam ellipse contained within the ANSI 4-step quadrangle. (Note: May be on cutsheet, otherwise need letter from manufacturer– A 4-step MacAdam ellipse is required in the current specification)
- Color Shift:  $Du'v' < 0.003$  at 6000 hours of operation (Note: Letter from manufacturer)
- Fidelity Index (Rf):  $\geq 80$  (Note: Likely will eventually be on cutsheet, but currently need letter from manufacturer)
- Gamut Index (Rg):  $97 \leq Rg \leq 110$  (Note: Likely will eventually be on cutsheet, but currently need letter from manufacturer)
- Hue-Bin One Fidelity (Rf,h1):  $> 78$  (Note: May eventually be on cutsheet, but currently need letter from manufacturer)
- Hue-Bin One Chroma Shift (Rcs,h1): between -9% and 9% (Note: May eventually be on cutsheet, but currently need letter from manufacturer)
- Violet Fraction: Where white matching is required, provide violet fraction between 4% and 6% (Note: Letter from manufacturer and sole source justification. Currently only LED product is available Soraa Ambient.)
- Life: LED Luminaires must have a minimum L70 lumen maintenance value of 60,000 hours. (Cutsheet – note increase from the L70 of 50,000 hours required in the current specifications)
- Correlated Color Temperature (CCT) of 4000 degrees K. (Cutsheet)
- Flicker: Comply with IEEE 1789-2015 (Note: Letter from manufacturer)
- Warranty: 5-year (Note: Cutsheet)



## CHAPTER 12 COMMUNICATIONS

### 12-1 GENERAL.

The planning and engineering of communications systems for Military Medical Facilities must conform to the design criteria contained in this chapter. These facilities use various integrated voice, data, imaging, visual, video information, electronic security, and telemedicine systems to provide quality healthcare. Not all systems listed in this chapter apply to all projects. The Designer of Record must consult with the Design and Construction Agent to establish the systems that are required for each specific project. All Devices identified as "Servers" by the Using Agency are required to be located in the Server Room (CMP01) including Systems operating in a client server environment, such as Interactive Television (ITV), Nurse Call and Electronic Security.

#### 12-1.1 Design Criteria.

Communication systems, equipment, and facilities must be designed in conformance with the most recently published versions of: ABA, NFPA 70, NFPA 72, NFPA 99, NFPA 101, Telecommunications Industry Association TIA-568, TIA-569, TIA-606, TIA-607, TIA-758, DHA Technical Requirements-Guidance LAN-WLAN Modernization, DHA Technical Requirements Document-Data Center Design, and applicable Using Agency standards and criteria. In the event conflict with any Standards this UFC take precedence. This UFC does not take precedence over Code Requirements.

#### 12-1.2 Approved Product Lists (APLs).

Electronic equipment included with the various systems must utilize, to the greatest extent practicable, equipment listed on the Joint Interoperability Testing Committee (JITC) APL and the Defense Information Systems Agency (DISA) Unified Capability (UC) APL.

### 12-2 COMMUNICATIONS SPACES.

#### 12-2.1 Telecommunication Rooms (TRs).

TRs must be located central to the area served and not be located on exterior walls. TRs must not share walls with electrical rooms or mechanical spaces.

The Communications Designer of Record (DOR) is to design space requirements and layout of each TR based on the following:

- a. Size and equip the TRs with utility support in according with TIA 569-D, DHA Technical Requirements-Guidance LAN-WLAN Modernization, DHA Technical Requirements Document-Data Center Design, project specific criteria and Table 12-1 below.
- b. Floor space is to be square or rectangular in shape and have no minimum dimension less than 10 feet in length. Door must be 180

degree outswing with no window. For Security requirements, see Chapter 5 Antiterrorism (AT) and Physical Security.

- c. TRs are to be vertically stacked and no rooms having wet utilities may be located above them.
- d. Floor space is to be reserved for Network and WLAN equipment in accordance with TIA 569-D Table 3 based on the number of WAO and WLAN outlets to be served within the service area of the specific TR.
- e. DOR is to account for all additional equipment to be installed within each TR and adjust the floor space requirements to accommodate the additional non-network equipment.
- f. DOR is to maintain 3 foot access requirements in front of and behind all equipment as installed, either Government provided or Contractor provided, and whether rack mounted or wall mounted.
- g. TRs are three dimensional spaces and utilize the total volume for equipment and maintenance. In accordance with the above criteria, there must be no plumbing, ductwork, conduits or other materials within the TR unless they directly support the TR. If ceiling surface is a roof, condensate protection must be provided and installed to the extent required for the protection of room contents.
- h. Dedicated power panels must be provided to serve each TR for each branch of the electrical systems (normal and essential electrical systems) required for service in each TR. Locate the power panels in the nearest Electrical Room in accordance with Electrical Requirements in this UFC.
- i. Electrical services and outlets are to be installed for the Network racks as directed in the DHA Technical Documents - Data Center Design. Power source is as directed in Table 12-1. Power for other equipment must be as required by the network manufacturer. If no power is specified for a particular rack, a quad duplex service outlet must be provided at each rack.

**Table 12-1 Essential Electrical System Emergency Power Branch Assignment for Communication Systems**

<b>Communications Systems</b>	<b>Branch Assignment</b>
Telephone Switching System (TSS) <sup>1</sup>	Life Safety (517.32.D)
PAPD	Life Safety (517.32.D)
Radio Paging (RP)	Life Safety (517.32.D)
Physiological Monitoring (acute areas)	Critical (517.33.A[3], a-g)
EMS Radios	Life Safety (517.32.D)
Local Area Network (LAN) Electronic Equipment at TR <sup>2</sup>	Critical/Life Safety <sup>3</sup> 517.33.A(5)/517.32.D
NTS System	Critical (517.33.A[9])
Nurse Call (NC), including subsystems <sup>4</sup>	Critical (517.33.A[5])
Telephone Rooms and TRs, other than data switch	Critical (517.33.A[7])
IRES (Radio repeater system)	Life Safety (517.32.D)
Electronic Security	Equipment
Wireless Access	Power over Ethernet (PoE) supplied from LAN electronic equipment in TR
<p>1. When installed within the facility. If installed in separate structure, telephone system must have a properly rated EPS designed in accordance with NFPA 70 Section 700 with the operational characteristics and requirements of the served Military Medical Facility. Provide one quad power outlet near every data outlet in all facilities.</p>	
<p>2. For the purposes of this document, LAN electronic equipment does not include any individual computer workstations. Individual computer workstations must need to be addressed on a case by case basis with the Using Agency. Provide racks in the appropriate communications spaces to support VoIP switches. Media Converters locations for analog devices must be coordinated with the Using Agency.</p>	
<p>3. LAN electronic equipment at the TR is to be treated as part of the TSS in facilities with Voice over Internet Protocol (VoIP)-based TSS or facilities utilizing wireless telephone instruments that are VoIP PoE and rely on TR primary power for functionality.</p>	
<p>4. Includes infant or patient tracking systems and door access systems interfaced with the NC System.</p>	

### **12-2.2 Penthouse Equipment Room.**

When one or more penthouses are designed as part of the facility, an equipment room must be located within one of the penthouses, typically the highest penthouse. In facilities without a penthouse that are equipped with an IRES or EMS system, an equipment room must be provided on the highest floor of the facility. The room must be used to house equipment for the Radio Page (RP) System, Intrafacility Radio Reinforcement System (IRES), Network Time Synchronization (NTS) System, and Emergency Medical Service (EMS) Systems. Also, provide weatherproof conduit penetrations to antennas for coaxial cables and emergency power for equipment in accordance with Table 12-1. Pathways must be provided from the 24-hour monitoring location to the penthouse equipment room to support the EMS radio coaxial or control cables as required for the facility.

### **12-2.3 Communications Radio Equipment Room (COM04).**

A separate communications headend equipment room with sufficient space for personnel circulation and equipment maintenance must be provided in hospitals and medical centers for headend equipment such as interactive television (ITV) and cable television (CATV), public address and program distribution (PAPD), and security equipment. Design the room, including utility support, in accordance with TIA-569-A and project-specific criteria. Systems operating in a client server environment, such as Interactive Television (ITV), Nurse Call and Electronic Security systems must have the server component of the system located in the Server Room.

### **12-2.4 Integrated Monitor and Alarm Room.**

A central communication room must be provided in hospitals and medical centers. The central communication room size must be based on the quantity of wall-mounted graphic displays, annunciator displays, and other monitor and control equipment. Install monitors, annunciators, and control equipment in the room for any or all of these systems:

- a. Fire detection and alarm system with mass notification controller.
- b. Generator monitor and alarm system.
- c. Medical gas monitors and alarms.
- d. Electronic security workstations for security monitoring and control of access control, intrusion detection, and video surveillance.
- e. Public address master microphone and paging zone selector panel.
- f. RP console.
- g. NC failure alarm and Code Blue and other Code Call Annunciator Stations.

- h. Refrigeration alarms for the morgue, pharmaceuticals, vaccines, blood bank, and other mission critical refrigerators.
- i. Elevator Emergency Phones.

#### **12-2.5 Server Room (CMP01).**

A separate main Information Systems Server room must be provided in accordance with DHA Technical Requirements Document-Data Center Design. The room must be sized to accommodate the equipment planned for installation in the space. The designers must provide power distribution, HVAC with temperature and humidity controls, access control, fire detection, alarm, suppression, uninterruptable power supplies (UPSs), and voice and data cables to support the GFGI and CFCI equipment. The Fiber Main Distribution Frame (FDMF) must be located in this room and all fiber backbone cables in the facility must be terminated on the FDMF. Fiber from each Building Distribution Frame (BDF) must also terminate on this frame. The room must be equipped with sound dampening finishes. Cables must be distributed via racks above the equipment cabinets. The Server component of all systems operating in a client server environment must be located in the Server Room.

#### **12-2.6 Telecommunications Entrance Facility (EF) COMC2**

Provide a separate entrance facility (EF). The entrance facility is the space housing the point of entrance of the telecommunications service. It's the demarcation point between the outside plant cabling and the inside plant distribution cabling. Medical Centers and Community Hospitals require two separate EFs with physically separate feed paths in accordance with NFPA 99.

### **12-3 OUTSIDE PLANT INFRASTRUCTURE AND CABLING.**

#### **12-3.1 Outside Plant Purpose.**

Provide connectivity to the Installation Wide Area Network (WAN), the Installation telephone system, and other Installation systems as required by the project-specific requirements via a system of underground ducts and cables.

#### **12-3.2 Outside Plant Duct Work.**

All outside plant cabling must be installed in underground ductwork. A system of maintenance holes and or hand holes must be provided at appropriate industry standard and best practice distances and bend radii. All buried ducts provided by the project must be encased in concrete from the nearest manhole or hand hole. Provide a minimum of two ducts, each 4 inches in diameter, to each project. All of the 4-inch ducts must be fully populated with inner ducts. Fabric mesh inner ducts are acceptable. Each unused duct or inner duct must be provided with a nonmetallic pull cord.

### **12-3.3 Outside Plant FO Cable.**

Each project must be provided with single-mode fiber optic (FO) cable. The FO cable must connect to the nearest connection point available to the Installation WAN. Projects that do not have a Health Care Occupancy component must be provided with a single path consisting of a minimum of 12 strands of single-mode FO cable. Projects with a Health Care Occupancy component must be provided with a minimum of two diverse, physically independent, redundant pathways, each with 48 strands of single-mode fiber. The two fiber paths must be connected to two different Installation WAN nodes and be routed into two different service entrance facilities in the project.

### **12-3.4 Outside Plant Twisted Pair Copper Cable.**

Twisted pair copper cables must be provided as necessary when required for telephone, security, legacy Medical Systems and or devices inoperable with VoIP technologies or other project-required connectivity to their various Installation systems. The number of twisted pairs must be based on the facility requirement plus 50 percent spare capacity rounded up to the next larger standard cable size.

Hospital projects must be provided with two independent, diverse, and physically independent and redundant pathways for twisted pair copper connectivity. The two redundant paths must be routed into the entrance facility (ies) in the hospital.

### **12-3.5 Outside Plant CATV Cable.**

CATV outside plant cables must be coordinated with the CATV on the Installation. A single connection to the Installation CATV service from a single service entrance facility must be provided when required by the project. It is acceptable for CATV cable to not be installed in the underground duct system; however, it must be installed underground.

## **12-4 DOD NETWORK ASSESSMENT AND AUTHORIZATION PROCESS REQUIREMENTS.**

All information systems must be certified for compliance with DoD security requirements and accredited for operation by a designated official from the Using Agency. The assessment and authorization process is a standard process under which all DoD information systems must achieve and maintain their Authority to Operate. Reference UFC 4-010-06 for requirements.

### **12-4.1 IP Addressable Systems.**

All systems that are IP addressable and interface with the Assured Network must be certified to operate. The assessment and authorization process is initiated by the Using Agency, the Information Management Department Information Assurance (IMD-IA) Office with the information being provided by the system vendor or provider. Medical systems must be accredited according to the manner in which the system must be used by the Medical Treatment Facility. The Using Agency will determine the assessment and authorization process requirements. The assessment and authorization process must require input and possible system modifications by the systems vendor or provider

and support from the Using Agency. The Using Agency IMD-IA office is the point of contract for all Accreditation and Certification requirements.

#### **12-4.2 Existing Systems.**

Current Systems that may require DoD Assessment and Authorization and must comply with UFC 4-010-06 and/or a Certificate of Networkiness includes, but is not limited to:

- a. ITV Systems
- b. Networked NC Audio Visual (NCAV) Systems
- c. NC Tone Visual (NCTV) Systems in inpatient facilities that are linked to the Networked NCAV Systems
- d. RP System
- e. Electronic Security System (ESS)

#### **12-5 NETWORK TIME SYNCHRONIZATION (NTS) SYSTEM.**

##### **12-5.1 Purpose.**

Provide a NTS in projects if there are systems that require precise time synchronization where there is no existing NTS capability available.

12-5.1.1 Provide an NTS System that must receive precise date and time data from a global positioning system (GPS) satellite and distribute this data to all Telecommunications Systems in the facility that require precise date and time synchronization.

12-5.1.2 Provide a GPS receiver with built-in sensitive antenna to receive precise data and time from GPS satellite transmission. The GPS receiver must be weatherproof and constructed for indoor or outdoor installation. The GPS receiver must be located for unobstructed reception from the GPS satellite.

12-5.1.3 Provide all interconnecting hardware, software, and cabling to link to the various Telecommunications Systems.

##### **12-5.2 Date and Time Properties.**

Date and time synchronization must automatically occur at least once a day. Time synchronization must typically be within +/-0.02 seconds. Date synchronization must include automatic time zone and updating for daylight saving time and leap year.

##### **12-5.3 Electrical Power.**

NTS System and equipment must be powered from the essential electrical system emergency power critical branch per Table 12-1. AC-powered equipment must be protected by a UPS unit that must provide at least 15 minutes of full power during an AC

power failure. UPS units must comply with UL 1778 and 47 Code of Federal Regulations (CFR) Part 15.

## **12-6 TELEPHONE SYSTEM CRITERIA.**

### **12-6.1 Type of Service.**

The Military Medical Facility must utilize a VoIP based telephone system, if available. The type of service available on the Installation and the project-specific criteria must determine the type of service provided. A mix of the two types of telephone systems may be used in the same facility.

### **12-6.2 Central Telephone Equipment.**

The Military Medical Facility must receive high reliability service from the Network Enterprise Center (NEC). All redundancy and reliability requirements of NFPA 99 must be met.

#### **12-6.2.1 Telephone System Features.**

The features listed below must be provided with the telephone system per the project-specific requirements. All required hardware and software to provide these features must be included:

- a. Call detail recording
- b. Automatic diagnostics with local and remote alarms
- c. Remote diagnostics
- d. Power fail automatic restart
- e. Automatic call distribution
- f. Voice mail service

#### **12-6.2.2 Emergency Stand Alone Service.**

Facilities with a Health Care Occupancy Component must have the ability to make telephone calls internal to the facility in the event all connections to the Installation are severed. The VoIP service for Facilities with Health Care Occupancies must be provided over networks with Assured LAN Services (ASLAN).

### **12-6.3 Integrated Intercommunication (Intercom) System.**

These intercom systems must be completely provided by the telephone system hardware and software with no external equipment. These intercom systems must provide communication among department heads, secretaries, Non-Commissioned Officers in Charge (NCOICs), and other designated staff members.



For dedicated intercom services, see Section 12-8.

#### **12-6.4 Patient Bedside Telephones.**

Telephones with a dial pad in the handset or the handset integrated into the bedrail must be provided in patient bedrooms. The project DOR must coordinate patient telephone service with the NEC utilizing low cost disposable instruments.

#### **12-7 TELECOMMUNICATIONS INFRASTRUCTURE SYSTEM (TIS).**

Provide a TIS throughout the facility and must be designed and installed in accordance with the most current version of UFC 3-580-01, TIA-568, TIA-569-A, TIA-606, and tested in accordance with TIA-568-B and the DHA Technical Guidance LAN-WLAN Modernization. The TIS must be a universal wiring network to serve all of the voice and data needs of the facility. The TIS must include horizontal and backbone unshielded twisted pair (UTP) copper cables and FO backbone cables. The TIS must support voice, facsimile, data, voice grade wireless network and other special services within the facility. All TIS backbones to TRs supporting the Clinical Information System(s) must have dual cable feeds occupying dual pathways in accordance with all requirements of NFPA 99 for the category of the facility under construction. The TIS cables must be installed in conduit and cable tray. All cables must be terminated on both ends. Cables and outlets must be marked in accordance with the local Installation standard. TIA-606-B must be followed. For Installations outside the contiguous United States, shielded twisted pair cables may be required by the project-specific criteria.

##### **12-7.1 UTP Copper Backbone Cable.**

Provide a dedicated multi-pair UTP copper cable to support voice applications must be run from the BDF to each TR. The riser-rated cable must be sized to accommodate the initial installed capacity plus 50 percent. In facilities with an installed TSS, the associated MDF must replace the BDF cited here. Backbone copper cables must be terminated on patch panels. For new facilities in which VoIP is to be installed, the backbone copper cable to each TR must be reduced to the minimum count needed to accommodate legacy medical systems, alarm and signaling circuits. Minimum size must be 25 pair.

##### **12-7.2 FO Backbone Cable.**

Provide a minimum of 24 strands of single mode fiber optic cable between the FMDF to each TR. All TIS backbones to TRs supporting the Clinical Information System(s) must have dual cable feeds occupying dual pathways in accordance with all requirements of NFPA 99 for Category 1 and 2 facilities. The FMDF must be located in the server room or location prescribed in the project-specific criteria. The actual number of strands to each TR must be in accordance with project-specific criteria. Patch panels must be used to terminate all backbone FO cables. When VoIP service is to be used, the number of FO backbone cables must be revised per project-specific criteria. Where multiple vertical stacks of TRs are used in projects with a Health Care Occupancy

component, a 12-strand single-mode FO cable must connect each of the TRs on the top of each stack.

### **12-7.3 Horizontal Copper Cable.**

The horizontal cable must consist of 4-pair UTP cable rated Category (Cat) 6A or higher. The cable must be installed between patch panels in the TRs and the user outlets. The horizontal UTP cable must support the voice and data needs of the user. When a VoIP system is to be used there will be no difference or distinction between voice and data cable.

### **12-7.4 Horizontal FO Cable.**

Horizontal FO cable must only be installed when prescribed by project-specific criteria in coordination with DHA/FE.

### **12-7.5 Work Area Outlets (WAO).**

WAO outlets must be located to support user work stations throughout the facility. A standard outlet must consist of a minimum 4 11/16 inches X 4 11/16 inches X 2 1/2 inches deep back box with a plaster ring that is equal to the wall thickness plus covering and a 1 inch conduit to the cable tray and totaling 2 5/8" deep, minimum. The cover plate must include four available positions for jacks. All UTP jacks must be 8 pin modular rated at Cat 6A or higher. Standard outlets must at a minimum contain three wired jacks in accordance with DHA Technical Requirements-Guidance LAN-WLAN Modernization. Two outlets (of 3) jacks each) per 120 square foot room are recommended. The facility must not be wired to support uncertain future possible changes. Desk outlets must be mounted 18 inches above finished floor. A minimum of 6 inches of slack on each cable must be coiled into the outlet box

#### **12-7.5.1 Equipment**

Provide additional outlets, as required, to support both Log Cat A and Log Cat C equipment, paying particular attention to locations such as laboratories, radiology, Inpatient bedrooms, nursing team centers, and conference rooms as prescribed in project specific criteria, and especially the Project Room Content (PRC) List.

#### **12-7.5.2 Wall Telephone Outlets.**

Provide single position modular jack telephone outlet designed to support wall-mounted telephone sets that are Architectural Barriers Act (ABA)-compliant. Use faceplates for wall height telephone outlets that have one ANSI/TIA/EIA Cat 6-rated jack and studs for mounting a wall-type telephone set. Where restricted by casework, adjust outlets and appropriately note on the floor plan and elevation.

#### **12-7.5.3 Modular Furniture Outlets.**

Modular Furniture Outlets may be accommodated by wall-mounted or floor-mounted WAO outlets where appropriate, or by the use of consolidation points or standard wall

outlets as allowed by TIA-568 and UFC 3-580-01 open office wiring requirements. The Intermediate Termination Point may be located either above the ceiling, or in the distribution zone with connecting conduit to the modular furniture connection point. The use of “power poles” is permitted if included in the project-specific criteria.

#### **12-7.5.4 Pharmacy Ceiling Outlets.**

Provide ceiling height outlets in Pharmacy locations to accommodate clinical systems. The designer of record must coordinate the location and number of outlets with the Using Agency and DHA/FE.

#### **12-7.5.5 GFGI Systems.**

Provide outlets to support Government Furnished Government Installed systems. Coordinate with the Using Agency and DHA/FE to determine what systems are to be installed and the data wiring and outlets required to support the systems.

#### **12-7.5.6 Elevator TIS Outlet.**

Cabling and a TIS outlet must be provided in elevator machinery rooms for each elevator car for the connection of elevator telephone sets. Telephone instruments must be furnished by the elevator supplier and be a direct ring-down or hotline to a 24-hour staffed location.

#### **12-7.5.7 Conference Room Outlets.**

Conference rooms must contain outlets to support voice, data, video teleconferencing, and emergency operations. In addition to the voice and data outlets along the walls, outlets must be provided under conference tables to accommodate voice and data instruments and connections for computer inputs to a wall-mounted flat-screen monitor. Configuration must be as directed by project-specific criteria.

#### **12-7.6 Data Communications Wireless Access Points (WAPs).**

Design of new Military Medical Facilities must include site preparation for a voice grade and Real Time Location Services (RTLS) wireless data network with future growth. The outlet configuration will be designed in accordance with DHA Technical Requirements-Guidance LAN-WLAN Modernization. This site preparation must consist of providing outlet boxes and cable in trays or conduit for the WAPs. The outlets for the WAPs must be installed above the ceiling and must be a standard size TIS outlet. Two Cat 6A cables must be installed from the nearest TR and terminated on modular jacks in the outlet. To establish the configuration for location of the WAP outlets, a desktop survey of the floor plans using commercial software tools must be made by the designer. Adjustments to obtain the final WAP configuration must be based on a physical survey using active equipment. Project-specific criteria must determine the specific method to be used.

### **12-7.7 Cable Tray.**

Provide cable trays above the suspended ceilings in the corridors for all communications systems cables. Cable trays must be located just above the ceiling and must be designed and installed to provide 12 inches of clearance above and on at least one side of the cable trays to ensure ease of accessibility for future wiring changes. The cable tray system design and installation must be in full compliance with TIA-569-A. Unless authorized by the project-specific criteria, J-Hooks must not be used for new construction projects; they may be used in alteration projects or alteration portions of projects where cable trays are not part of the existing structure and space above the ceiling is limited. Cable trays for communications systems must not be shared with electrical power systems cables. For facilities with an IBS, cable trays must be installed in the distribution zone.

### **12-7.8 Grounding.**

All TRs must include a telecommunications ground bus (TGB) bar and be grounded in accordance with TIA-607 and project-specific criteria.

## **12-8 DEDICATED INTERCOM SYSTEM.**

Intercom functions must generally be provided by the telephone system. Dedicated point-to-point intercom systems, where required by the project-specific requirements and where the use of the telephone system or direct ring-down telephone circuits is not satisfactory, may be provided. Intercom systems must provide two-way voice communications and may include one- or two-way video communications. Other intercom functions and all dial intercom functions must be by the telephone system.

## **12-9 NURSE CALL SYSTEMS.**

### **12-9.1 Purpose.**

Provide NC Systems that communicate patient and caregiver calls for various levels of assistance from appropriate caregiver responders. The communications must include explicit information about the specific call location and level of assistance needed. Consult with the Using Agency to determine if the nurse Call Systems are required to interface with the Medical Facility network and are thus required to meet the Assessment and Authorization Process outlined in this chapter. All Nurse Call Systems provided must meet the requirements of NFPA 99 and be UL 1069 listed for the purpose as installed. Nurse Call systems that are connected to the Clinical Information System must meet the above requirements and be identified for use in a shared network environment. The Clinical Information System must be managed and controlled as prescribed in NFPA 99.

### **12-9.2 Categories and Typical Locations.**

NC Systems categories with typical installation locations must be as defined here.

### **12-9.2.1 Nurse Call Audio Visual System (NCAV)**

Networked NCAV Systems must provide simultaneous multimedia communication of calls that includes alert tones, visual indicators, selectable voice annunciation, alphanumeric video displays, full duplex voice intercom, and alphanumeric RP.

12-9.2.1.1 Provide Networked NCAV Systems in inpatient Military Medical Facilities located in each of these areas: inpatient units (wards); ICUs; Cardiac Care Units (CCUs); Labor & Delivery (L&D) units; Emergency Department and associated Urgent Care units; surgical suite; pre-operative holding areas; and post-operative recovery unit.

12-9.2.1.2 If required and defined by Appendix A Behavioral Health Design, provide Networked NCAV Systems for inpatient behavioral health units with tamperproof equipment and with limited patient call capability. These units may also require a staff emergency and video monitoring capability provided as part of the Electronic Security System (ESS) and Appendix A Behavioral Health Design.

### **12-9.2.2 Nurse Call Tone Visual System (NCTV)**

NCTV Systems must provide simultaneous multimedia communication of calls that includes alert tones, visual indicators, selectable voice annunciation, and alphanumeric video displays. NCTV communications media do not include full duplex voice intercom.

12-9.2.2.1 NCTV Systems must be provided in Ambulatory care clinics, blood donor centers, dental clinics and ancillary services areas.

12-9.2.2.2 NCTV Systems must be provided in inpatient Military Medical Facilities in the ambulatory care clinic, blood donor station, and ancillary service areas, and integrated or networked with the provided Networked NCAV Systems.

### **12-9.3 Procurement.**

An NC System must be procured as a turn-key system from a single qualified NC Systems contractor.

### **12-9.4 UL 1069.**

NC Systems must be UL 1069 listed for the purpose as installed.

### **12-9.5 Common Criteria.**

The application design, configuration, and installation of all NC Systems must comply with these common criteria:

#### **12-9.5.1 Electronic Supervision.**

Code Blue Stations, User Assigned Code Stations, Annunciator Stations, Master Stations, Patient Stations, and associated wiring to each of these stations must be electronically supervised in accordance with UL 1069, with any failure condition

annunciated at the local control or monitoring station, and communicated as further defined herein.

### **12-9.5.2 Keep-Alive Feature.**

All personal computer (PC)-based Master Stations and Annunciator Stations must be equipped with a “keep-alive” feature that must automatically re-boot the station if it is turned off for any reason.

### **12-9.5.3 Call Assurance.**

When a call is placed from any call station or device, a call assurance indicator lamp on the station or device must illuminate to indicate that the call has been registered on the system. This call assurance lamp must remain illuminated until the call is cancelled.

### **12-9.5.4 Alert Signal.**

A signal to alert staff to a call must be an audio tone or an alternate voice annunciation.

12-9.5.4.1 It must not be possible to adjust an alert tone audio volume below a minimum perceptible level. The adjustment of the alert tone audio volume on any type of station or light must be a maintenance procedure and not an operator function. The alert tone can be temporarily muted for the current call, with automatic reset so that the alert tone must again sound when the next call is placed.

12-9.5.4.2 A computer-generated voice annunciation of a call, by type and location, must be provided as a user selectable alternative alert to the sounding of an alert tone. This alternative must not affect or substitute for any displayed call information.

### **12-9.5.5 Tone and Visual Call Signals.**

#### **12-9.5.5.1 Call Annunciation.**

Each call must be annunciated by various combinations of alert tones and visual indicators. The specific combination and distribution of alert tone and visual signals must be as outlined here for each type and source of call. In inpatient Military Medical Facilities that have NCTV Systems and NCAV Systems, the tone and visual signals for each call type and priority must be consistent for the all NCTV and NCAV Systems.

- a. Visual illumination colors, with steady or flashing illumination, must provide clear and absolute distinction between call types and priorities on the dome lights, zone lights, duty stations, Annunciator Stations, and Master Stations. Visual call indications on zone lights must be absolutely identical to the visual call indications on dome lights for each call type.
- b. Tone signals must sound at different intermittent pulse rates to allow adequate distinction between call types and priorities on the duty stations, Annunciator Stations, and Master Stations, and where tone

signals are required on dome lights. In accordance with UL 1069, audible annunciation is required at all zone lights.

#### **12-9.5.5.2 Call Routing – Zone Lights.**

- a. Within a patient care unit, the routing of any call type from any call station to any zone light(s) must be programmable to allow annunciation of calls on any one or more zone lights from any combination of call stations. Each zone light must be programmed to present a pattern of illuminated zone lights that the caregiver can follow from any corridor in a patient care unit to get to the corridor where a call has been initiated from a patient care room.
- b. Zone Light Activation Matrices must be developed. Each zone light must be given an identification (ID) number, and the ID number must be indicated on the Telecommunications Systems drawings. There must be a Matrix developed for each patient care unit served. Each Matrix must list all zone lights within the patient care zone by their ID number, and must relate each zone light to the patient care room(s) where calls are originated that must activate each zone light. These Matrices must be included with the submittals.

#### **12-9.5.5.3 Call Annunciation Priorities.**

All systems must simultaneously process and signal all calls regardless of the priority. However, when several different priority calls are present on the system at any one time, the signal for the highest priority call must take precedence on call tones and visual indicators that signal several call categories. For example: If dome and zone lights signal an emergency call by a solid red light and intermediate pulse rate tone, and a Code Blue call by a flashing red light and fast rate tone pulse, the dome and zone lights must signal a flashing red light and fast pulse tone when there is both an emergency and code call at the same time.

#### **12-9.5.5.4 Call Processing Rates.**

- a. Except for Code Blue and other Code calls, all calls must be processed from the origination call station to the call destination within 4 seconds.
- b. Code Blue and User Assigned Code calls must be processed from the origination call station to the call destinations within 8 seconds. The 8 seconds must include a 4 second delay in the initiation of these calls to allow for caregivers to quickly abort code calls that were accidentally initiated.
- c. The call processing rates defined here do not include any RP System transmission time for the alphanumeric RP of calls.

#### **12-9.5.6 Code Blue and User Assigned Code Stations.**

Code Blue stations and User Assigned Code call stations must each be physically separate stations and not part of any other station. These stations must be mounted as high as practical to be out of reach of children.

#### **12-9.5.7 Dome and Zone Lights Lamps.**

Dome and zone lights must use LED lamps. Incandescent lamps are unacceptable.

#### **12-9.5.8 Main Terminal and Equipment Panels.**

The main terminal and equipment panel for each system must be located in the TR nearest the area serviced and provide for system wire termination, low-voltage power supplies as required to power all stations and lights, and circuitry for system operation as determined by the system application design. Locate the main terminal equipment in the Server room if it is determined by the Using Agency to be a Server.

#### **12-9.5.9 Standardized System Features and Capability.**

All of the systems in each NC Systems category must have the same standardized performance features and capability. System features and capability not required in a particular patient care unit may not be activated at the time of installation. However, the facility maintenance staff must be able to activate inactive features and capability at any time thereafter without assistance from the system contractor and without impacting the fundamental capabilities of the system.

#### **12-9.5.10 Electrical Power.**

NC Systems and equipment must be powered per Table 12-1. AC powered equipment must be protected by a UPS unit providing at least 15 minutes full power during an AC power failure. UPS units must comply with UL 1778 and 47 CFR Part 15.

### **12-9.6 Networked NCAV Systems.**

All NCAV Systems must be operational nodes of a totally integrated network of the major functional components and interfaces that provide a comprehensive facility-wide multimedia capability for the NC fundamental operations and enhanced supplemental operations.

#### **12-9.6.1 Operations.**

##### **12-9.6.1.1 Fundamental Operations.**

Provide the communication of these calls from within a patient care unit:

- a. Patient and caregiver calls for assistance and information
- b. Auxiliary medical device alarm calls



- c. Bed exit alarm calls.

#### **12-9.6.1.2 Enhanced Supplemental Operations.**

Provide enhanced supplemental operations to the fundamental operation for the routing of calls, data, and messages within patient care units and over a system-wide network to facilitate:

- a. Central annunciation of designated types of calls, including code calls and equipment failure alarms.
- b. Automatic downloading of patient Admissions-Discharge-Transfer (ADT) module data via interface with the Hospital Information System (HIS) local area network (LAN). Nurse Call systems that are connected to the Clinical Information System must meet the above requirements and identified for use in a shared network environment. The Clinical Information System must be managed and controlled as prescribed in NFPA 99.
- c. A central database for the logging of all calls and the generation of statistical management reports from a Call Logging Workstation and from designated HIS computer terminals.
- d. System operational status monitoring and maintenance from a Central Maintenance Workstation.
- e. Processing and transmission of NC data and messages to provided alphanumeric radio pagers or other wireless communications devices carried by on-duty staff. Also, processing of NC data and messages to GFGI-wide area alphanumeric pagers leased from a local Radio Common Carrier that are carried by on-duty and on-call staff.
- f. Allow swing routing of calls from any call station to any Master Station in the unit or in adjacent areas.

#### **12-9.6.2 NCAV Systems Network.**

Provide an independent, dedicated industry standard network with industry standard LAN technology, software, protocols, equipment, and cabling to interconnect all NC major functional components and major interfaces into an integrated NC capability for facility-wide communications in support of all NC functions. The facility HIS LAN must not be used for the NC System LAN.

The NC network must be an adjunct network of the facility HIS LAN. Therefore, the application design must incorporate the requirements of the Assessment and Authorization Process and must comply with UFC 4-010-06 (reference paragraph 12-4). This must include the system network architecture, software, hardware, and security requirements. Nurse Call systems that are connected to the Clinical Information System must meet the above requirements and identified for use in a shared network

environment. The Clinical Information System must be managed and controlled as prescribed in NFPA 99.

#### **12-9.6.2.1 NCAV Servers**

Servers, with appropriate operation and application software, must provide central databases for all of the systems, application programs and data, call logging data, interface with the facility HIS, interface with the facility RP or other wireless personal communications device system, and interface with the facility NTS System.

#### **12-9.6.3 NCAV Systems Major Components.**

Provide the NCAV Systems major components listed here at the locations indicated. Also refer to paragraph 12-9.5 Common Criteria.

##### **12-9.6.3.1 Bed interface outlet stations**

A bed interface outlet station must be behind each GFGI inpatient bed equipped with a communications side rail or bed exit system. The station connector must be compatible with the connector on the GFGI-provided bed communications cable.

##### **12-9.6.3.2 Patient stations**

Single Patient Stations must be in each inpatient unit bedroom, inpatient unit exam and treatment rooms, ICU and CCU bedrooms, bedrooms, LDR bedrooms, emergency exam treatment rooms and cubicles, pre-operative holding rooms and cubicles, and recovery rooms and cubicles.

##### **12-9.6.3.3 Cord Sets and Holders.**

Provide these types of cord sets for each patient care unit and space:

- a. **Pillow Speaker Cord Sets.** A pillow speaker cord set must be provided for each patient station in inpatient bedrooms, ICU and CCU bedrooms, LDRP bedrooms, and LDR bedrooms. In these locations, the patient station cord set receptacle must accommodate the simultaneous use of both a pillow speaker cord set and a push button or pneumatic cord set. Cord set must be a component in the UL 1069 Listing for the system or approved by the Nurse Call Manufacturer for use with their system.
- b. **Push Button Cord Sets.** A push button cord set must be provided for each patient station in each inpatient unit exam and treatment room, emergency exam and treatment room, pre-operative holding room or cubicle, and recovery room or cubicle. Provide push button cord sets for 25 percent of the patient stations in all other rooms and cubicles. Cord set must be a component in the UL 1069 Listing for the system or approved by the Nurse Call Manufacturer for use with their system.

- c. Pneumatic Cord Sets. Pneumatic cord sets must be provided for 25 percent of the patient stations in all rooms and cubicles. Cord set must be a component in the UL 1069 Listing for the system or approved by the Nurse Call Manufacturer for use with their system.
- d. Cord Set Holder. A wall bracket must be provided to hold cord sets when not in use.
- e. Push Button Stations. Call cords must not be provided in Behavioral Health areas. Only push button station must be provided in Behavioral Health units when required by Appendix A Behavioral Health Design.

#### **12-9.6.3.4 Code Blue Stations**

Code Blue Stations must be provided, as a minimum, in each inpatient bedroom, inpatient exam and treatment rooms, ICU and CCU bedrooms, LDRP bedrooms, LDR bedrooms, Operating Rooms, CT Scanner Room Control Point, cystoscopy rooms, bronchoscope rooms, oral surgery operatory, emergency exam and treatment rooms and cubicles, trauma rooms, procedure rooms, pre-operative holding room and cubicles, and recovery rooms and cubicles. Code Blue stations in Behavioral Health units must be in accordance with Appendix A Behavioral Health Design.

#### **12-9.6.3.5 Infant Distress Code Stations**

Infant Distress Code Stations must be provided, as a minimum, in each NICU basinet area, LDR/LDRP room resuscitation area, nurseries, and C Section Operating Rooms. This will be replaced by a Code Blue button in facilities that do not support a separate response team for infant code calls.

#### **12-9.6.3.6 Device alarm jack stations**

Device alarm jack stations must be adjacent to each patient station.

#### **12-9.6.3.7 Duty stations**

Duty stations must be provided, as a minimum, in staff lounges, clean core areas, decontamination rooms, equipment cleanup and storage rooms, clean and soiled workrooms, linen rooms, trash rooms, nourishment pantry, medical preparation areas, staff work and lounge rooms.

#### **12-9.6.3.8 Emergency pull cord stations**

Emergency pull cord stations must be adjacent to each toilet accessible to the public or patient to include public, patient and staff toilets, shower, tub, and each CCU and ICU toilet/lavatory location. In showers, locate the station on the shower head wall and above the shower head; these stations must be water resistant. In Behavioral Health areas emergency pull cord stations must be replaced with emergency push button stations.

### **12-9.6.3.9 Emergency Push Button Stations**

Emergency Push Button Stations must be provided, as a minimum, in each NICU; Intensive, Continuing Care, and Isolation bassinet location; Level 1 Holding Nursery, Admission.

### **12-9.6.3.10 Staff Stations**

Staff Stations must be provided, as a minimum, in dayrooms, conference rooms, waiting rooms, interview rooms, emergency procedure and trauma rooms, and Nursery parent teaching and feeding rooms.

### **12-9.6.3.11 Staff Stations with Staff Assist Call Button**

Staff station with an emergency call button must be provided, as a minimum, in each OR, cystoscopy room, cardiac catheterization room, angiography procedure room, Nursery procedure room, isolation and seclusion ante-rooms, day rooms, interventional procedure room, Dialysis Stations, Blood Donor Stations, Immunization Stations and pediatric play rooms. Behavioral Health units including inpatient and outpatient Behavioral Health areas must be equipped, in accordance with Appendix A Behavioral Health Design.

### **12-9.6.3.12 Master Stations**

Master Stations must be provided, as a minimum, in the inpatient unit Nurse Station and in any sub-Nurse Stations, ICU and CCU, L&D unit, NICU, Emergency Department, pre-operative holding area, recovery unit, and at the control desk in the surgical suite. Master Station features must include:

- a. Dome lights without a tone device must be located outside the entrance to each room and cubicle that has a patient station, emergency pull cord station, emergency push button station, Code Blue station, or Code Pink station. Dome lights with tone device outside the door to a toilet room that is entered from within a procedure room.
- b. Zone lights must be located at each corridor intersection in multi-corridor units.
- c. White Board (WB) Stations must be located in the Nurse Station or Team Center per project-specific criteria, in each inpatient unit, ICU and CCU, and L&D unit.

### **12-9.6.4 Peripheral Equipment.**

Provide the Networked NCAV Systems peripheral equipment defined here at the locations indicated.

12-9.6.4.1 Provide Main Central Annunciator Station to annunciate all Code calls and failure alarms from throughout the entire NC System until they are cancelled at the call origination point. The main central Annunciator Station must be located per project-specific criteria.

12-9.6.4.2 A Call Logging Workstation must be provided for the collection, processing, storage, statistical analysis, report generation, and archiving of call data; and printout of real-time call data by patients name, sex, age, room, and bed, including time each call is placed, answered at the Master Station or Central Annunciator Station, set on service reminder, and cancelled. This workstation must be located areas directed buy the Using Agency.

12-9.6.4.3 Two Maintenance Workstations must be provided. These workstations must provide for remote monitoring, diagnostics, and troubleshooting of failures throughout the system, testing of major NC System components, and for the downloading and installation of software upgrades from the manufacturer. One workstation must be located in the IMD repair area for maintenance of the system LAN and servers. The second workstation must be located in the Facility Management Division electronics repair area for maintenance of the system stations and lights.

#### **12-9.6.5 Duplex Voice Intercom.**

Provide full duplex, non-blocking voice intercom between Master Stations and Voice Calling Stations (patient stations, staff stations, and duty stations) and for voice communications among all NCAV Systems. A simplex intercom that utilizes voice activated or other switching circuits that permit transmission in only one direction at a time, or which may clip portions of a two-way conversation, are not permitted.

#### **12-9.6.6 Networked NCAV Systems Interfaces.**

Provide the interfaces listed here at the locations indicated.

##### **12-9.6.6.1 GFGI Bed Side Rail Communications and Bed Exit System Interface.**

Provide interface at the Bed Interface Outlet Station via the bed communications cable. Side rail controls must allow initiation of a routing patient call and on/off control of room and reading lights. A bed exit system must initiate a bed exit alarm if the patient exits the bed.

##### **12-9.6.6.2 Interface for Remote Control of Over-Bed Lights.**

Provide interface for on/off remote control of the inpatient bedroom over-bed reading and room lights at each inpatient bed location via an interconnection to a solid-state, low-voltage light controller. (Reference Chapter 11 Electrical).

##### **12-9.6.6.3 ITV System Interface.**

Provide pillow speaker interface in accordance with 12-12, ITV System, at each inpatient station and the associated patient flat-panel, high-definition television (HDTV)

for these functions: HDTV on/off and channel selection control and remote sound from a pillow speaker cord set, patient interactive access to on-demand and scheduled education and message channels, and access to interactive programs such as patient surveys.

**12-9.6.6.4 RP Interface.**

Provide networked NCAV System RP server interface to the RP Systems (reference paragraph 12-11) to automatically route calls to the RP System for transmission to radio pagers assigned to caregivers and supporting staff.

**12-9.6.6.5 HIS Interface.**

When directed by the Using Agency Networked NCAV System HIS server must be capable of interfacing directly to the facility HIS to automatically download patient ADT module data for use by master stations and whiteboards and to interface to wireless networked personal communications devices carried by the facility staff members. Nurse Call systems that are connected to the Clinical Information System must meet the above requirements and identified for use in a shared network environment. The Clinical Information System must be managed and controlled as prescribed in NFPA 99.

**12-9.6.6.6 NCTV Systems Interface.**

Provide networked NCAV System interface to the NCTV Systems (reference paragraph 12-9.7) to integrate the NCTV Systems with the enhanced supplemental operations of the Networked NCAV System. This requires the NCTV Systems to add a network capability and link the network to the NCAV System LAN.

**12-9.6.6.7 NTS System Interface.**

Provide NTS System (reference paragraph 12-5) interface with an NCAV System network server for time and date synchronization.

**12-9.6.7 NCAV Systems Call Types.**

The following are NCAV System call types:

- a. Patient Routine Call
- b. Patient Priority Call
- c. Cord Disconnect Call
- d. Bed Disconnected Call
- e. Emergency Call
- f. Staff Assist Call
- g. Code Blue Call

- h. Infant Distress Call
- i. Medical Device Service Alarm Call
- j. Bed Exit Alarm Call
- k. Duplex Voice Intercom Call
- l. Service Dispatch and Reminder Call
- m. Information Message Call
- n. Failure Alarm Call

#### **12-9.6.8 Call Annunciation Modes.**

Each call must annunciate throughout the system by various combinations of alert tones, visual and video indications, and the digital display of alphanumeric data and text messages. The specific annunciation for each call type must be as described herein for each type and source of call.

12-9.6.8.1 On Master Stations, an intermittent call alert tone must sound. A liquid crystal display (LCD) touch-screen color video monitor must graphically and digitally display the call type and call origination room and bed. Alphanumeric data and text message information must indicate associated patient data, associated caregiver duty assignment data, and associated radio pager assignment data. The facility user room name and number must identify the call origination room. Call data, information, and status must remain displayed on the video monitor until the call is cancelled.

12-9.6.8.2 On Central Annunciator Stations, an intermittent call alert tone must sound. An LCD touch-screen color video monitor must alphanumerically indicate the call type and call origination patient care unit and room, or failure alarm call type and equipment location. The video monitor display must indicate at least ten calls simultaneously, with a provision to indicate that there are additional calls that can be viewed by a scrolling function that must bring into display all other calls that are not simultaneously displayed. The facility user room name and number must identify the call origination room. Call data, information, and status must remain displayed on the video monitor until the call is cancelled.

12-9.6.8.3 On duty stations, LED lamp(s) with steady or flashing illumination must indicate calls by the call priority level, and sound an alert tone.

12-9.6.8.4 On pagers or other networked wireless personal communications devices carried by the staff, an alert tone or vibration must activate, and an alphanumeric data and text message must indicate the ID of the room and bed where the call originated and the call type. For routine calls that have first been answered by an attendant, the pager or other networked wireless personal communication device must also indicate a service dispatch message that has been sent by the attendant. The user room name and number must identify the call origination room and bed.

12-9.6.8.5 The alert tones and visual and video indication displays for all types and priorities of calls must continue until the call has been answered and cancelled. Except for routine calls, all calls must be cancelled at the originating call station. Routine calls can be cancelled at either the originating station or the answering Master Station on audio equipped systems. TVNC calls must be cancelled at the originating station.

**12-9.6.9 Call Annunciation Priorities.**

12-9.6.9.1 The annunciation of all call types must be sequenced in a four level priority rank order, from a high of Number 1 to a low of Number 4, as listed in Table 12-2. Coordinate Code Call names and meanings and priority levels with the Using Agency.

**Table 12-2 Call Annunciation Priorities**

Priority Level	Call Type
#1 Code	Code Blue
	Code Calls
#2 Emergency	Emergency
	Bed Exit Alarm
	Medical Device Emergency Alarm
	Staff Assist
	Failure Alarm
#3 Priority	Patient Priority
	Call Cord Disconnected
	Bed Cable Disconnected
#4 Routine	Patient Routine
	Medical Device Routine Alarm
	Voice Intercom - Staff and Duty Stations

12-9.6.9.2 All calls must be simultaneously processed regardless of priority. However, when several different priority calls are present on the system at any one time, the highest priority call must take precedence over lower priority calls. For Master Stations and Annunciator Stations that display calls in a list, the displayed list of calls must be in priority order, with the highest priority calls at the top of the displayed list. All calls, regardless of priority, must remain indicated until cancelled.

12-9.6.10 Call routing throughout the networked systems must be software programmable to provide the selectable call routing defined here. All patient data and caregiver data associated with any call must automatically accompany the call routing.

- a. Calls from patient toilet and shower rooms that are entered from within the patient bedroom must visually annunciate on the dome light located outside the entry into the patient bedroom.



- b. Calls from patient toilet rooms entered from within a procedure room must visually and audibly annunciate on the dome light located outside the entry door into the toilet room, and visually on the dome light located outside the entry into the procedure room.

12-9.6.10.1 Call Routing – Master Stations. Master Station features must provide the attendant with the selectable call routing defined here. This must include the routing of voice intercom between any Master Station and any audio call station. If the network or call routing feature fails, all calls must revert to the original UL 1069 designated master station.

- a. A default call routing scheme within each patient care zone must be established for calls between each call originating station and the Master Station(s) in an NCAV System. If there is more than one Master Station in an NCAV System, then the default call routing to each Master Station must be user defined and approved by the User Representative.
- b. Any call from any call originating station can be selectively routed to, and answered from, any Master Station in any NCAV System.
- c. Any one Master Station in any NCAV System must be able to handle any combination of calls, or all of the calls, from any call originating station in any NCAV System.
- d. Any combination of Master Stations throughout all NCAV Systems can be programmed to operate in a parallel mode. In this parallel mode, all calls that would normally be routed to a Master Station must now be routed to all Master Stations in the parallel mode at the same time. The parallel mode can be either a default setting or an attendant selectable mode at any Master Station.
- e. An authorized attendant, under password protection, at any Master Station must be able to perform a selective call capture function whereby any call originating station that has been default programmed for call routing to any other Master Station must be rerouted to the capturing Master Station. The attendant must be able to selectively capture single rooms, groups of rooms, or all the rooms that have been default assigned to another Master Station. The rerouting of calls from any room must include all associated patient and caregiver data that has been programmed for the room, including caregiver duty assignments.
- f. Master Stations that have relinquished reception of calls to another Master Station via the call capture function must retain the capability to manually originate RPs.

- g. An authorized attendant, under password protection, at any Master Station must be able to recapture calls from any NCAV System or any call station that has been captured by another Master Station by performing a selectable recapture function.
- h. All call routing, call capturing, and call recapturing operations must be password protected.

12-9.6.10.2 Call Routing – Main Central Annunciator Station. In addition to the normal local call annunciation on a Master Station and the RP of the call, the call types listed here must also be automatically routed to the Main Central Annunciator Station in the Central Communications Room.

- a. Code Blue calls
- b. Infant distress calls
- c. Failure alarm calls

12-9.6.10.3 Call Routing – Infant Distress Central Annunciator Station. In addition to the normal local call annunciation on a Master Station, and the radio page of the call, all infant distress calls must also be automatically routed to the Infant Distress Central Annunciator Station.

12-9.6.10.4 Call Routing – Duty Stations. All duty stations must be equipped to annunciate all call types.

12-9.6.10.5 Call Routing – Call Logging Server and Call Logging Workstation. All call data from all NCAV Systems must be routed to the call logging database in the call logging server. This call logging database can then be accessed from the NCAV System Call Logging Workstation and HIS computer terminals designated per project-specific criteria and as coordinated with the facility IMD Representative. Call logging application programs for accessing the call logging database and for generating call data reports must be installed and set up on the designated HIS computers terminals. Failure of the Call Routing or Call Logging feature, including but not limited to out of logging space conditions or network failure, must not result in any degradation of basic services as defined in UL 1069.

12-9.6.10.6 Call Routing – Maintenance Workstations. All failure alarm calls from all major functional components of the network and all systems must be routed to the Maintenance Workstation(s). Failure of the Call Routing or Call Logging feature, including but not limited to out of logging space conditions or network failure, must not result in any degradation of basic services as defined in UL 1069.

12-9.6.10.7 Call Routing – RP System Pagers. All calls and failure alarms from throughout the Networked NCAV Systems must be routed by NC selectable duty assignment programming via the NCAV RP Server interface (reference 12-11, RP Systems) for transmission to RP System Pagers assigned to designated on-duty

caregivers and support staff. Failure of the Call Routing Radio Page feature must not result in any degradation of basic services as defined in UL 1069.

## **12-9.7 NCTV Systems.**

### **12-9.7.1 Overall Configuration and Capability.**

There are two typical configurations for the application of NCTV Systems: one configuration for installation in blood donor centers, and ambulatory healthcare centers, and a second configuration for installations in inpatient Military Medical Facilities. Both configurations must provide the same fundamental operations for patient and caregiver call and communications operations. However, the configuration for inpatient Military Medical Facilities must provide enhanced supplemental operations for signaling and data handling from the NCTV Systems when integrated with the enhanced supplemental operations of an NCAV System in the facility. The common fundamental operations of both configurations and the enhanced supplemental operations for inpatient Military Medical Facilities must be as defined here.

In inpatient Military Medical Facilities that are equipped with Networked NCAV Systems (reference paragraph 12-9.6 Networked NCAV Systems) that provide enhanced supplemental operations, the NCTV Systems must be linked as nodes on a network provided as part of the NCTV System, with the NCTV network linked to the Networked NCAV Systems network. This must provide the NCTV Systems with the same NCAV Systems enhanced supplemental communications capabilities including alphanumeric RP or other wired networked personal communications device, central annunciation of code and failure calls, and the central logging of all call transactions.

### **12-9.7.2 NCTV Systems Major Components and Locations.**

The following lists the NCTV System major components and the component locations:

12-9.7.2.1 Emergency Call Station Locations. The minimum location requirements are provided below.

- a. Patient toilet rooms (beside each toilet)
- b. Staff toilet rooms that may be used by patients (beside each toilet)
- c. Public toilet rooms that may be used by patients (beside each toilet)
- d. Patient showers (waterproof unit on shower head wall above shower head)
- e. Recovery rooms and cubicles (adjacent to the patients head)
- f. Hydrotherapy and whirlpool tub areas (waterproof unit adjacent to each whirlpool)
- g. Treatment rooms (adjacent to the patients head)

- h. Phlebotomy Station
- i. Blood drawing cubicles (beside the chair or stretcher)
- j. Physical Therapy treatment and exercise areas
- k. Procedure rooms
- l. Pulmonary function laboratory
- m. Immunization rooms
- n. Dialysis rooms
- o. Cardiac Rehab/Exercise area
- p. Allergy Injection rooms
- q. Electroencephalogram (EEG) Testing rooms
- r. Stress Electrocardiogram (ECG) and Echocardiogram rooms
- s. Radioisotope lab
- t. Patient dressing and locker areas
- u. Dental oral surgery rooms
- v. CT Scanner Room
- w. MRI Scanner Room
- x. Behavioral Health Outpatient Clinic facilities as required in Appendix A Behavioral Health Design

12-9.7.2.2 Code Blue Station Locations. The minimum required locations are provided below.

- a. Treatment and procedure rooms
- b. Stress ECG and treadmill rooms
- c. Physical Therapy Exercise Area
- d. Blood draw rooms
- e. Renal dialysis room
- f. Immunization rooms
- g. Chemotherapy rooms

h. MRI rooms

12-9.7.2.3 Dome Lights Locations.

Outside each room above or beside each door to the room and outside each cubicle equipped with an Emergency Call Station or Code Blue Station

12-9.7.2.4 Zone Lights with Chime Locations.

At corridor intersections within multi-corridor areas

12-9.7.2.5 System Annunciator Station Location.

- a. In accordance with project-specific criteria or as reflected in the CONOPS or PRC List.
- b. In the team center or main staff work area serving the clinic or ancillary service

**12-9.7.3 Types of Calls and Alarms Signaled.**

The following is a list of the types of calls and alarms signaled:

- a. Call from a patient or caregiver for emergency assistance from an emergency pull cord station or an emergency push button station
- b. Call from a caregiver for Code Blue assistance from a Code Blue station
- c. Failure alarms from electronically supervised wiring, Code Blue Stations, and Annunciator Stations

**12-9.7.4 Call Priorities.**

The processing of calls must be sequenced in a two-level priority rank order, from a high of Number 1 to a low of Number 2, as listed here:

Priority Number	Call Categories
1	Code Blue
2	Emergency and Failure Alarm

**12-9.7.5 Annunciator Station Function and Call Routing.**

When a call is activated on an NCTV System, an intermittent call alert tone must sound on the system Annunciator Station. The Annunciator Station LCD touch-screen color video monitor screen must alphanumerically identify the call type and call origination

room. The Annunciator Station must handle and display multiple calls simultaneously. All calls must continue to be indicated until cancelled at the call origination station.

- a. A call signal cannot be cancelled at any Annunciator Station; it must be cancelled at the originating call station. A tone mute icon can be used to temporarily silence the current call tone signal. The tone signal circuit must be automatically reset so that the tone must again sound when the next call is placed.
- b. For Behavioral Health ambulatory clinics, in addition to the wired staff assist features of the nurse call system, a supervised wireless staff assist button activating the nurse call staff assist signal, logging, dome light and related zone light(s) must be provided in accordance with Appendix A Behavioral Health Design.

### **12-9.8 Enhanced Supplemental Operations.**

In Military Medical Facilities equipped with Networked NCAV Systems (reference 12-9.6, Networked NCAV Systems) and with the enhanced supplemental operations described here, including an onsite RP System, all of the NCTV Systems must be configured with an integrated network that is interconnected with the Networked NCAV System to fully utilize these NCAV enhanced supplemental operations for the routing of calls and data to facilitate:

- a. The processing and transmission of call data and messages to alphanumeric pagers or other wireless networked personal communications device carried by the staff
- b. Central annunciation of code calls and failure alarms
- c. A central database for the logging of all calls, and the generation of statistical management reports
- d. Central system operational status monitoring and maintenance from a Maintenance Workstation

This enhancement must require the NCTV Systems fundamental capability be upgraded with all necessary networking hardware and software, and the provisioning of identical Radio Pagers for each NCTV System. Also, the NCTV Systems Annunciator Stations must be upgraded with the hardware and software, including a keyboard and mouse, to allow manual alphanumeric RP from the Annunciator Stations.

### **12-10 INTERNAL CELLULAR, PAGING AND ANTENNA SYSTEM (IRES).**

Provide an RF Distribution System for facilities over 50,000 gross square feet and those facilities which have an internal signal strength of less than 80 dBm at the project site to receive and distribute simplex and duplex RF communications throughout the facility to support communications from fire, emergency and other first responder systems. Permitted operations include the RP System and the local fire service radio system.

The signal sources may be either external or internal to the facility, and the service is to be capable of bi-directional services internally or externally. Systems that service fire radios must meet cabling and battery backup requirements as may be presented by the local Installation Fire Marshall. Other frequencies and system requirements must be determined by the project-specific criteria. Site requirements and all field strength surveys, engineering, and testing are to be provided as part of the system.

## **12-11 RADIO PAGING SYSTEMS.**

### **12-11.1 Radio Paging (RP).**

Provide one ultra-high frequency (UHF) paging system to include paging receivers for 100 percent coverage within the health facility. The RP system must operate on a military UHF page frequency assigned by the Post Frequency Coordinator. The designer must request a military UHF frequency for the RP System from the Installation Frequency Coordinator. The RP system design must ensure 100 percent coverage inside the Military Medical Facility.

### **12-11.2 Page System Interfaces.**

The RP System is required to interface with these systems as noted in their respective sections of this chapter: Telephone System (numeric paging only) (reference paragraph 12-6), NC Systems (reference paragraph 12-9), ESS (reference paragraph 12-14), IRES (reference paragraph 12-10).

### **12-11.3 System Function.**

The system must utilize tone and vibration alert paging receivers that display an alphanumeric message. Each pager must be accessible by dialing a discrete set of digits via the telephone system. Access must also be available at the central control console within the health facility when provided and at each audio visual (AV) NC System control station. Facility design must include space in the penthouse area, AC power, and conduit for control and coaxial cables.

### **12-11.4 Emergency Response Team Pagers.**

Pagers assigned to members of the code and other emergency response teams must provide at least two separate and distinct alert tones: one for routine and priority calls and one for emergency calls. These pagers must have two separate access codes: one for calls to individual pagers and one for group alerting. The group alerting code must signal all units in the group simultaneously.

### **12-11.5 Antennae Type and Mounting.**

Antenna type and mounting height must be selected to provide complete facility coverage. Provide antenna and mast conforming to TIA-222 and TIA-329. A wireway, conduit, or cable tray must be provided from the transmitter location to the antenna. In the presence of an IRES, an appropriate low-level signal from the RP System

transmitter must be directly injected into the IRES to supply coverage. With this design, an external antenna is not required.

#### **12-11.6 Power Requirements.**

All RP equipment must be connected to the life safety branch of the EPS and rated for continuous duty.

#### **12-11.7 Transmitter and Encoder.**

The transmitter must comply with FCC Emission Designator 11K0F2D for 12.5 kilohertz (KHz) Narrow Band Transmission, and appear as a listed device with the JITC. Provide a Maintenance and Programming station. Provide two transmitters and encoders in a hot-swap configuration.

### **12-12 INTERACTIVE TELEVISION (ITV) SYSTEM.**

The ITV system is a proponent funded television receiver system used for patient entertainment and education and funded separately from MILCON.

Provide the following for this system:

#### **12-12.1 Electrical Power.**

Provide power for the requested systems from the electrical system in accordance with the electrical code and Table 12-1 and the device location provided by the System Contractor.

#### **12-12.2 Empty Conduit and Boxes and Cable Trays.**

Provide junction boxes and empty conduits with pull strings to install cables. Calculate cable requirements into cable tray capacity calculations and provide adequate cable tray capacity to support these systems. Identify any system wiring and location that is designed to be connected utilizing the facility TIS. Provide outlets, wiring and patch panel capacity in TRs to support these systems. Provide conduits from the penthouse to the antennas mounted on the roof and, if required, conduits for coaxial and control cables from Ambulance Dispatch to the penthouse equipment.

#### **12-12.3 Structural Support.**

Provide structural support and sufficient mounting space for the antennas.

#### **12-12.4 Equipment Space Support.**

Provide floor space and racks as required in communications support rooms. Include this equipment in the TR Floor Space Calculations where equipment is located in TRs.



## **12-13 TV BROADBAND DISTRIBUTION NETWORK.**

### **12-13.1 Purpose.**

Provide a TV broadband distribution network to receive and distribute TV program channels from a commercial TV service to provided flat-panel HDTVs throughout a stand-alone clinic facility.

### **12-13.2 Procurement.**

Procure the entire TV network as a turn-key system from a single qualified TV network contractor.

### **12-13.3 Commercial TV Service.**

The Proponent User, in accordance with project-specific criteria, must select and separately contract for the provision of TV program channels from a locally available commercial TV service.

The system application designer must request and obtain from the Proponent User the ID of the TV service that must be used, and obtain a detailed description of the facility space and infrastructure requirements that must be provided to accommodate the TV service signal reception or entry and any headend equipment to be installed in the facility.

#### **12-13.3.1 Facilities and Infrastructure for the TV Service.**

Provide the facilities, space, and infrastructure to accommodate the installation requirements of the commercial TV service.

12-13.3.1.1 For CATV service, provide the facilities and infrastructure to accommodate the routing of the CATV service trunk-line entry from the nearest source on the Installation to the network headend in a facility TR, including the CATV trunk-line and trunk amplifier (as may be required). The trunk-line routing into the facility may be via an underground duct or an underground cable link from an overhead pole adjacent to the facility site.

12-13.3.1.2 For SATV service, provide the facilities and infrastructure to accommodate the installation of an SATV service roof-top antenna, cable entry into a facility TR, and any required headend equipment provided by the SATV service.

#### **12-13.4 Broadband Distribution Network.**

The broadband distribution network must consist of cable and equipment to receive, process, and distribute all TV program channels received from the TV service. The TV distribution network can be configured either as a broadband coaxial network or a gigabit Ethernet network for the communication of all TV channels to all TV outlets throughout the facility. The distribution network must conform to the radiation standards specified in 47 CFR Part 76.

12-13.4.1 An RF broadband coaxial cable distribution network must include quad shield coaxial cables, power supplies, amplifiers, splitters, directional couplers and taps, attenuators, terminators, TV outlets, and any other required equipment.

12-13.4.2 A gigabit Ethernet network must be configured as a dedicated network including network switches, patch panels, FO and UTP cable, modular TV outlets, and equipment racks for the mounting of all equipment. The network must conform to TIA/EIA criteria standards. The fiber and copper cabling and network outlets required for this system are in addition to those required for the Telecommunications Infrastructure System (TIS) in this chapter.

### **12-13.5 TV Outlets and Signal Level.**

12-13.5.1 TV outlets must be provided in these types of rooms:

- a. Waiting Rooms
- b. Conference Rooms
- c. Staff Lounges

12-13.5.2 For Coaxial/RF based systems, TV signal level at each TV outlet must be between +3 dBmV and +9 dBmV.

### **12-13.6 Flat-Panel HDTVs and Connecting and Mounting Items Configuration.**

12-13.6.1 Provide devices to interface the flat-panel HDTVs with the TV distribution network.

12-13.6.2 Provide jumper cables for connection from the flat-panel HDTVs to the TV outlet jack and any network interface devices. The cable between the network interface device and the HDTV must be an HDMI cable.

12-13.6.3 Provide wall brackets and furniture mounts for the mounting of all flat-panel HDTVs. Coordinate the requirements for in-wall support plates for wall mounting brackets with the architectural and structural design, and the requirements for casework or furniture mounts with the architectural design and equipment planner.

### **12-13.7 Electrical Power.**

Provide a quad AC power receptacle at all TV outlet locations. The AC power receptacle must be mounted in a separate back box from the TV outlet back box, and located adjacent to the TV outlet.

## **12-14 ELECTRONIC SECURITY SYSTEM (ESS).**

Electronic security system requirements are included in Chapter 5 Antiterrorism (AT) and Physical Security.

## **12-15 RADIO AND PUBLIC ADDRESS (PA) SYSTEM.**

### **12-15.1 System Purpose.**

Provide a zoned loudspeaker paging and zoned music program system that must evenly distribute recorded or live voice messages or recorded music throughout designated areas of the facility. The distributed sound must be free of noise and distortion. It must be balanced and highly intelligible per the Modified Rhyme Test (MRT) of ANSI/ASA S3.2-2009. The system must be capable of individually and simultaneously paging all separate independent zones provided by the system configuration.

### **12-15.2 System Components.**

Provide a system consisting of these components.

#### **12-15.2.1 Headend Equipment.**

##### **12-15.2.1.1 Equipment Racks.**

Provide floor-mounted equipment racks to house all headend equipment.

##### **12-15.2.1.2 Auxiliary Inputs.**

Provide rack space and preamplifier input ports for a minimum of two auxiliary inputs to support project-specific requirements.

##### **12-15.2.1.3 Distribution Equipment.**

Provide mixer-preamplifiers, power amplifiers, mixer amplifiers, input modules, partial octave graphic equalizers, and input selection switches for connecting program inputs to the distribution system.

##### **12-15.2.1.4 Monitor Panel.**

Provide a system monitor panel with selector switch and speaker to check each zone output, voice input, and zone selection.

##### **12-15.2.1.5 Telephone Interface Couplers.**

Provide telephone interface couplers for loudspeaker paging. The telephone interface must be VoIP-based. The number and type of telephone lines provided must be based on the system configuration. There must be one unique telephone number provided for each local loudspeaker paging zone, and for the all-call loudspeaker paging to all zones in the system. Telephone system interface equipment must be provided as part of the PA system. Loudspeaker paging control functions such as call answer, tone announcement before the page, and automatic preset time-out must be accomplished by the telephone interface couplers.

- a. Coordinate and define the telephone system interface and programming requirements for loudspeaker paging access with the Using Agency.
- b. Local zone loudspeaker paging access from the telephone system must be programmed for access only from telephones within the local zone.
- c. Wide area and all-call loudspeaker paging access from the telephone system must be restricted to selected telephones per project-specific criteria.

### **12-15.2.2 Loudspeaker System.**

Provide low power loudspeakers for uniform sound distribution at low volume levels. For maximum coverage, corridor speakers must be spaced at a maximum of twice the ceiling height apart. Speakers located in individual rooms must be provided with separate volume controls. Paging speakers in designated areas such as a pediatrics clinic must be provided with a volume control and bypass relay. The bypass relay must allow for all-call paging to bypass the local volume control and be heard at normal system volume. Speakers are not provided in normally occupied spaces such as patient rooms, office, exam, and treatment spaces. Provide speakers that are designed to provide even sound dispersion over the 20 Hz–20 KHz frequency range within the entire area the speaker is to cover.

#### **12-15.2.2.1 Indoor Loudspeaker Assemblies.**

Provide cone speakers with enclosures and baffles in all indoor locations.

#### **12-15.2.2.2 Outdoor Loudspeaker Assemblies.**

Provide weather resistant cone speakers with enclosures and baffles for outdoor ceiling locations. Provide horn speakers for outdoor wall mount locations.

#### **12-15.2.3 Microphones.**

Provide the type and quantity of microphones with control switches and mounts in accordance with project-specific criteria.

### **12-15.3 System Configuration.**

Provide a system configured in accordance with these specifications:

#### **12-15.3.1 All Call.**

Provide an all zone paging capability, which must have priority over all other paging in every facility except the Mass Notification System as described in Chapter 14 Fire Protection and Life Safety. All call may be accessed via a microphone, telephone, or

both. The microphone access must have priority over the telephone access for all zone types.

### **12-15.3.2 Local Zones.**

Provide local loudspeaker paging zones for individual clinics, each ancillary service or administrative department where patients are seen for diagnosis or treatment, and each inpatient unit. Local zones must be accessed using the telephone system, microphones, or both, as directed by project-specific criteria. Local zone paging must be overridden by all call paging. A volume control must be provided in a controlled access area inside the local zone floor space.

### **12-15.3.3 Medical/Dental Clinic Zoning.**

Provide a separate wide area zone for medical and a separate wide area zone for dental in combined medical/dental clinics. An all call for the entire facility must be maintained.

### **12-15.3.4 Auditorium Zone.**

In facilities that have an auditorium equipped with an auditorium AV system (reference paragraph 12-17), loudspeaker paging in the auditorium must be limited to an all-call loudspeaker page call only.

### **12-15.3.5 Microphone Applications.**

The installation of microphones must be limited. The project-specific criteria must provide guidance on the number and location of microphone stations. Telephone system input is required for all systems and zones and is the preferred method.

### **12-15.4 System Performance.**

The system must provide even sound distribution throughout the designated area, +/-3 decibel (dB) for the 1/1 octave band centered at 4,000 Hz. The system must provide uniform frequency response throughout the designated area, +/-3 dB as measured with 1/3-octave bands of pink noise at locations across the designated area selected by the Contracting Officer. The system must be capable of delivering 75 dB average program level with additional 10 dB peaking margin sound pressure level (SPL) in the area without causing the associated amplifier to exceed normal operating specifications for power or distortion. Unless otherwise specified, the reference SPL is 20 micro pascal. Minimum audio SPL to ambient noise ratio must be at least +15 dB in all areas. System must have no audible hum, noise, buzz, or rattles at any loudspeaker. Electrical/acoustic signal-to-noise ratio for the entire system must be at least 66 dB.

### **12-15.5 Electrical Power.**

PA system equipment in inpatient Military Medical Facilities must be powered from the essential electrical system emergency power life safety branch per Table 12-1. AC powered equipment must be protected by a UPS unit that must provide a minimum of

15 minutes of full power during an AC power failure. UPS units must comply with UL 1778 and 47 CFR Part 15.

#### **12-15.6 DoD Assessment and Authorization.**

The PA Systems must be certified in accordance with DoD Assessment and Authorization Process. This certification requires the system to have a number of security characteristics and features.

### **12-16 SOUND REINFORCEMENT SYSTEMS.**

#### **12-16.1 Purpose.**

Provide distortion- and noise-free, highly intelligible (per the MRT of ANSI/ASA S3.2-2009), balanced, and evenly dispersed sound reproduction and reinforcement from multiple sources to an audience in chapels, auditoriums, and large conference rooms as required by the Using Agency and project specific criteria. Provide video and computer display capability such that it is easily visible and readable from every area in the space being served.

#### **12-16.2 Inputs.**

Sound reinforcement systems must accept inputs from multiple sources such as wired and wireless microphones, digital audio and or video programming and playback devices, and PC-based programming.

12-16.2.1 The system must address the specific needs of the facility users for the space it must serve with regard to the number and types of inputs.

12-16.2.2 The major components of the system must consist of, but not be limited to:

- a. Preamplifiers and power amplifiers
- b. Partial octave graphic equalizers
- c. Sound mixer/amplifier
- d. Wired microphones with goose neck stands
- e. Wired handheld microphones
- f. Wireless microphones and wireless receivers
- g. Compact disc (CD)/digital video disc (DVD) recorders/players
- h. Auditorium wireless hearing assistance systems
- i. Room sound combiner and switching for auditoriums
- j. Volume controls

- k. Auxiliary input ports for at least two sources with preamplifiers and rack space for auxiliary source equipment
- l. Speakers including enclosures and baffles

**12-16.3 Headroom.**

Provide a system with a minimum of 3 dB of headroom.

**12-17 INTEGRATED AUDIO VIDEO SYSTEMS (AV)**

Provide integrated AV systems for each auditorium. The auditorium encompasses the ability to simultaneously perform all required functions in all sections of the auditorium in the case that the auditorium may be divided into multiple auditorium spaces by moveable partitions.

- a. Audio functions must be provided to allow for the functions described in 12-16, Sound Reinforcement System. In addition to those functions, provide monitor speakers for the stage area. Provide for sound feedback monitoring and stabilization. Provide wireless hearing assistance systems in auditoriums with receivers for a total of 5 percent of the auditorium capacity. Provide surround sound capability.
- b. Provide the ability to display video from various sources such that it is easily visible from all areas of the auditorium. Provide a video feedback screen such that a presenter may see what is being displayed from the stage. Provide motorized screen and data projectors or appropriate large flat-panel displays as specified by the Using Agency. Provide a control room to house equipment and a control console station. Provide the capability to record and reproduce presentations.
- c. Provide a control console to include video switching capability, audio switching and mixing, PTZ camera controls, motorized screen control, and lighting control for the auditorium.
- d. Provide the capability to control motorized screens, audio volume, record capability, and microphone controls from a podium or control station on the stage.
- e. Provide the capability to interface with the ITV System for the live broadcast of programs.

**12-18 PATIENT MONITORING AND TELEMETRY SYSTEMS**

An empty conduit system with pull cords must be provided for installation of GFGI equipment and cable for the monitoring system. All equipment including monitors, computers, and printers must be connected to the critical branch of the EPS. A GFGI UPS must be provided by the Using Agency.

## **12-18.1 Cardio-Pulmonary Respiratory Monitoring.**

Data entry points must be monitored by a central computer. A minimum of one 4-inch by 4-inch back box and one 1-inch conduit with pull cords must be provided from each data entry point to the communication system cable tray. Conduits with pull cords must be provided from the central physiological monitor computer location to the communication system cable tray. At a minimum, data entry and monitor points must be provided as specified here.

### **12-18.1.1 Emergency Room (ER).**

Data entry and monitor points must be provided for each trauma room, treatment room, treatment cubicle, and Nurse Station. At the Nurse Stations, provide conduit to the printer and monitor locations.

### **12-18.1.2 Surgical Suite.**

The surgical suite includes each OR with outlet located in the ceiling service console, each recovery bed, and including the isolation rooms, recovery area Nurse Station, and the anesthesia work room. At the recovery area Nurse Station, provide conduit to the printer and monitor locations.

### **12-18.1.3 Urology includes each cystoscopy room.**

### **12-18.1.4 ICU/CCU.**

ICU/CCU includes each bed and Nurse Station. At Nurse Stations, provide conduit to the printer and all monitor locations.

### **12-18.1.5 Step-down Units.**

At Nurse Stations, provide conduit to the printer and all monitor locations.

### **12-18.1.6 L&D Unit.**

This area includes each LDR, LDRP and C Section OR with outlet located in ceiling service console, each labor room, each recovery bed, and Nurse Station. At the Nurse Stations, provide conduit to the printer and all monitor locations.

## **12-18.2 Fetal Monitoring.**

A conduit with pull wire must be provided from each LDR, LDRP, labor room, stress test room and exam to a pull box above the ceiling at the Nurse Station. A minimum of one conduit with pull wire must be provided from the pull box to the Nurse Station for the monitors.



### **12-18.3 Neonatal Monitoring.**

A conduit with pull wire must be provided from each Intensive and Continuing Care bassinet location, LDR, LDRP, and each isolation room to a pull box above the ceiling at the Nursery Nurse Station.

### **12-18.4 Anesthesia and Respiratory Gas Analysis System.**

Conduit with pull wire must be provided to the anesthesia workroom, where the analyzer and central processing unit are to be located, from:

- a. Each OR ceiling column
- b. 25 percent of the patient service consoles in the surgical suite recovery area, to include the isolation rooms
- c. Each cystoscopy room at the head of the table
- d. One delivery recovery bed patient service console

Conduit must be provided to the anesthesia office suite and the blood gas lab for printer or cathode ray tube units. All conduit must be installed from the outlet to the cable tray system.

## **12-19 EMERGENCY MEDICAL SERVICE (EMS) COMMUNICATIONS.**

The EMS system consists primarily of GFGL radio equipment, which is used for voice and telemetry communications with military and civilian ground and air ambulances.

### **12-19.1 Electrical Power.**

Provide power for all radios and remote control units from the life safety branch of the emergency system when available.

### **12-19.2 Empty Conduit and Boxes.**

Provide junction boxes and empty conduits with pull strings to install cables. Identify system(s) and their location(s) that must be connected utilizing the facility TIS. Provide conduits from the penthouse to the antennas mounted on the roof and, if required, conduits for coaxial and control cables from Ambulance Dispatch to the penthouse equipment.

### **12-19.3 Structural Support.**

Provide structural support and sufficient mounting space for the antennas.

## **12-20 EMS RECORDER SYSTEM.**

Provide a multichannel recorder system as required by the Using Agency in hospitals and medical centers. The system must include these functions and features:

### **12-20.1 EMS Recorder Function and Features.**

The EMS recorder must typically be installed in the Ambulance Dispatch area. The system must be used to record voice communications on selected telephone lines and all EMS radios. The telephone lines recorded must include but not be limited to all active lines of the ER Nurse Station and all active lines of the Ambulance Dispatch telephones. The actual lines to be recorded must be determined by the project-specific requirements. Two-way audio from each of the EMS radios must be recorded. The recorder must, at a minimum, have these characteristics:

- a. Recording media must have a minimum of 24 hours of recording capacity.
- b. A minimum of ten channels plus one channel that records time in hours, minutes, and seconds for record retrieval. Channels must be calculated as one channel per each monitored telephone line, and one additional channel for each radio service monitored.
- c. A microprocessor-based control system that provides system control and diagnostics
- d. A rapid search system that enables fast retrieval of time-dated information
- e. Search and playback from digital memory while the system continues to record the prescribed channels

### **12-20.2 System Inputs and Mounting.**

The system must accommodate multiple input impedances to allow recording from the varied media identified. The system must be rack-mounted in a free-standing cabinet.

### **12-20.3 DoD Assessment and Authorization.**

The EMS Recorder must be certified in accordance with DoD Assessment and Authorization Process. This certification requires the system to have a number of security characteristics and features.

### **12-21 OTHER PROVIDED SYSTEMS**

The following systems may be provided on individual projects under separate funding from MILCON:

1. Electronic Message Signage.
2. Patient Bed System
3. Point of Care/Use system

4. Point of Sales
5. Patient Queuing
6. Sound Masking
7. Integrated OR above ceiling distribution
8. Infant protection
9. Clock System
10. Tracking and locating systems
11. Add-on optional Cellular service to IRES System
12. Surgical Instrument Tracking
13. Other Government provided systems that may be called in the Project Statement of Work.

**12-21.1 Electrical Power.**

Provide power for the requested systems from the electrical system in accordance with the electrical code and Table 12-1.

**12-21.2 Empty Conduit and Boxes and Cable Trays.**

Provide junction boxes and empty conduits with pull strings to install cables. Calculate cable requirements into cable tray capacity calculations and provide adequate cable tray capacity to support these systems. Identify system(s) and their location(s) that is to be connected utilizing the facility TIS. Provide outlets, wiring and patch panel capacity in TRs to support these systems. Provide conduits from the penthouse to the antennas mounted on the roof and, if required, conduits for coaxial and control cables from Ambulance Dispatch to the penthouse equipment.

**12-21.3 Structural Support.**

Provide structural support and sufficient mounting space for the antennas.

**12-21.4 Equipment Space Support.**

Provide floor space and racks as required. Include this equipment in the TR Floor Space Calculations where equipment is located in TRs.

*This Page Intentionally Left Blank*

CANCELLED

## CHAPTER 13 ACCESSIBILITY PROVISIONS FOR THE DISABLED

### 13-1 GENERAL.

This chapter provides design guidance on the application of accessibility provisions within DoDM MILCON. All Military Medical Facilities must be designed and constructed to be accessible to persons with physical disabilities in accordance with the ABA Accessibility Standard for DoD Facilities (DoD Standards) and implemented by DoD Policy Memorandum (Subject: Access for People with Disabilities) dated 31 October 2008.

### 13-2 GENERAL EXCEPTIONS.

Sites, buildings, and facilities are exempt to the extent specified by the ABA Accessibility Standard for DoD Facilities (DoD Standards).

### 13-3 DOD EXCEPTIONS/EXCLUSIONS.

Facility exceptions and exclusions to the DoD Standards are outlined in the DoD Policy Memorandum.

### 13-4 SPECIFIC MILITARY MEDICAL FACILITY REQUIREMENTS.

#### 13-4.1 Parking.

Provide accessible parking and passenger loading zone facilities for Military Medical Facilities as required by paragraphs F208.2.1, Hospital Outpatient Facilities; F208.2.2, Rehabilitation Facilities and Outpatient Physical Therapy Facilities; F209.3, Medical Care and Long-Term Care Facilities; and complying with Section 502, Parking Spaces, and Section 503, Passenger Loading Zones, of the DoD Standards.

#### 13-4.2 Patient Sleeping Rooms.

All patient bedrooms (sleeping rooms) and bedroom toilet rooms must be accessible. Turning space, clear floor or ground space, and toilet and bathing rooms within patient sleeping rooms must comply with Section 805, Medical Care and Long-Term Care Facilities, of the DoD Standards.

#### 13-4.3 Patient Dressing Rooms.

All patient dressing rooms must be accessible and located on an accessible route. In renovation projects, where structurally impracticable to make all dressing rooms accessible, one patient dressing room for each sex (or a unisex) on each accessible floor or level must be made accessible.

#### 13-4.4 Telephones.

If pay telephones are provided, comply with Section F217, Telephones, of the DoD Standards.

**13-5 WAIVERS.**

Any other deviation from the ABA Accessibility Standard for DoD Facilities must be made through the waiver process in accordance with the DoD Policy Memorandum.

CANCELLED

## CHAPTER 14 FIRE PROTECTION AND LIFE SAFETY

### 14-1 GENERAL.

This chapter provides policy and design guidance related to fire protection engineering and life safety for MTFs.

Where the specific term “general evacuation” is used in this chapter, it means that the response to a fire is to completely evacuate a facility. By comparison, where the specific term “defend in place” is used, it means that a particular set of actions is carried out, in response to a fire, by facility staff trained in taking those actions for assisting affected occupants in relocating to one or more predetermined safe locations within a facility.

### 14-2 BUILDING REHABILITATION.

For all projects involving rehabilitation work (as defined by NFPA 101), the Using Agency must have existing facilities evaluated by a Qualified Fire Protection Engineer (as defined by UFC 3-600-01) to determine the level of fire protection and life safety afforded the occupants as part of the scope development.

#### 14-2.1 Life Safety Assessment.

Planning for rehabilitation projects must include a Life Safety Assessment (LSA). For health care and ambulatory health care occupancies, the LSA must be performed in accordance with The Joint Commission (TJC) Statement of Conditions (SoC) as established in the “Life Safety” chapter of the *Comprehensive Accreditation Manual for Hospitals* (CAMH).

Wherever the term “life safety assessment” or “LSA” is used in this UFC, it must be considered to be a reference to “building assessment” as used in CAMH Update No 2, which is dated January 2018. In particular, Element of Performance No 2 in LS.01.01.01 of the CAMH indicates that the building assessment is used to determine compliance with the “Life Safety” (LS) chapter.

##### 14-2.1.1 Noncompliant documentation

If an LSA determines an existing facility, or any life safety provision or fire protection feature of the facility, to be noncompliant with NFPA 101, all identified issues of noncompliance must be documented and corrected.

##### 14-2.1.2 Equivalency

If an LSA determines a facility to be noncompliant with NFPA 101 for existing requirements, then an equivalent method, as allowed by the Designated Fire Protection Engineer (as defined in UFC 3-600-01), may be used to re-evaluate the facility. Any equivalency must be documented as part of the tabulation of deficiencies performed in surveys of existing facilities. If agreed upon by the Design and Construction Agent, Using Agency and DHA/FE, NFPA 101A may be used as an equivalency.

### **14-2.1.3 NFPA 101A assessment**

NFPA 101A may be used to assess existing facilities, including design concept development for life safety upgrade projects. If approved by DHA/FE in coordination with the Using Agency and the Design and Construction Agent, NFPA 101A may be considered for semi-permanent and contingency facilities.

### **14-2.2 Smoke Control or Management Systems.**

In facilities with smoke control or management systems, the design report, required by NFPA 92, must be provided as part of the LSA.

### **14-3 CONSTRUCTION OPERATIONS.**

A completed SoC (see previous section for Building Rehabilitation) must be provided in all projects requiring accreditation by TJC. The SoC is established in the *Comprehensive Accreditation Manual for Hospitals* and is used in a management process that continually identifies, assesses, and resolves deficiencies related to NFPA 101. Provide life safety and fire protection features, including TJC Interim Life Safety Measures (ILSMs), during construction as specified herein for projects involving rehabilitation work.

The Design and Construction Agent must provide an updated LSA based on actual built conditions to the Using Agency not later than initiation of clinical operations.

#### **14-3.1 Phasing.**

Phasing of construction and demolition operations must be planned so that the integrity of fire separations, smoke barriers, smoke partitions, exits, exit enclosures, and vertical openings is maintained. The phasing plan must ensure that obstruction of exits is avoided or minimized. If exits are obstructed during construction, provide alternate means of egress and exit routes during each phase of construction and identify the alternate routes on the construction drawings as part of the phasing plan(s). Include all ILSM proposed items in the phasing plans.

#### **14-3.2 Impairment of Existing Fire Protection Systems and Features.**

Minimize any impairments or disruptions to active fire protection features. Delineate phasing of construction to ensure that installations of new systems or modifications to existing systems are expedited. Where possible, maintain existing systems in service until the replacement work has been deemed operational. Prior to decommission, impairment, or disruption of fire protection equipment or features, ensure alternative procedures have been provided and approved. In addition, confirm official notification of system impairments and schedules have been provided consent.

### **14-4 AUTOMATIC SPRINKLER PROTECTION.**

Automatic sprinkler protection must be provided in accordance with UFC 3-600-01 except as modified in this section.



#### **14-4.1 Clarification of Spaces to Be Protected.**

Automatic sprinkler protection must be installed throughout all MTFs, including (but not limited to) telephone switch rooms, computer rooms, radiology and MRI suites, loading docks, communications and electrical equipment rooms, audiometric booths, vaults, and generator rooms.

##### **14-4.1.1 Communications and electrical rooms**

This UFC does not permit the omission of automatic sprinkler protection from either communications or electrical equipment rooms even though NFPA 13 may permit this exception.

##### **14-4.1.2 Audiometric Booths**

Automatic sprinkler protection must be extended into audiometric booths 16 square feet or more in area because these are considered occupiable spaces. So, such protection may be omitted from audiometric booths less than 16 square feet in area and having no single dimension greater than four feet in either length or width.

#### **14-4.2 Preaction and Deluge Systems.**

Neither preaction nor deluge sprinkler systems are permitted.

#### **14-4.3 System Supervision.**

Each sprinkler system must be electronically supervised for alarm, trouble, and supervisory conditions.

#### **14-4.4 Defend in Place.**

Where buildings are required to be subdivided into smoke compartments, the sprinkler system must be subdivided and supervised accordingly (per smoke compartment). All sprinklers in a given smoke compartment must be piped as one system and supervised by a dedicated control valve assembly (with check valve and water flow indicator).

#### **14-4.5 Components and Hardware.**

Components and hardware for automatic sprinkler protection must be provided in accordance with UFC 3-600-01 unless otherwise modified herein.

- a. Provide non-ferrous piping for all areas of MRI suites.
- b. Flow control (or “on-off”) sprinklers are not permitted.
- c. Flexible sprinkler connections are only permitted subject to adherence to the conditions of their listing or approval, including (but not limited to) a stainless steel protective covering listed or approved for that use.

- d. Provide institutional-type sprinklers throughout the fire compartment(s) or floor(s) where psychological treatment or behavioral rehabilitation is being provided.
- e. Provide concealed-type sprinklers with dust covers in all Category 1 and Category 2 spaces (as defined in NFPA 99).
- f. Provide quick-response sprinklers throughout animal housing facilities.

#### **14-5 PORTABLE FIRE EXTINGUISHERS.**

Provide portable fire extinguishers in accordance with NFPA 10 and this section for all MTFs, excluding those facilities not rendering medical treatment to patients, e.g., medical warehouses, central utility plants, and telecommunications buildings and those facilities where general evacuation is employed.

#### **14-6 FIRE ALARM, FIRE DETECTION, AND MASS NOTIFICATION.**

Provide fire alarm and fire detection in accordance with this section and UFC 3-600-01. Provide mass notification in accordance with this section as well as UFC 4-010-01 and UFC 4-021-01.

##### **14-6.1 Facility Fire Plan.**

In projects being delivered using the design-build acquisition strategy, a copy of the facility fire plan (as defined in NFPA 99), which was developed by the Installation, must be made available to the Design-Build Contractor in order for a complete design to be executed. In projects delivered using the design-bid-build acquisition strategy, a copy of this plan must be made available to the architect-engineer.

##### **14-6.2 Autonomous Control Unit and Local Operating Consoles.**

Provide each autonomous control unit and local operating console at constantly attended locations in either health care occupancies or ambulatory health care occupancies, or portions thereof.

##### **14-6.3 Occupant Notification.**

Occupant notification must be provided in accordance with NFPA 72 and NFPA 99 unless otherwise modified herein.

##### **14-6.3.1 Required areas**

Visual notification is required only in public accessible areas for all MTFs, including corridors and hallways, lounges and lobbies, waiting areas, cafeterias, dining areas, auditoriums, atria, conference rooms, and public restrooms.

### **14-6.3.2 Location**

Visual notification must be provided in view of all exits, nurses' stations, and at locations, such as in mechanical equipment rooms, where the operating noise level exceeds the level of the audible alarm as permitted by NFPA 72.

### **14-6.3.3 Evacuation procedures**

Evacuation procedures must be developed and provided in accordance with the Emergency Operations Plan (EOP) as established by NFPA 99 and CAMH Update No 2 or the Emergency Response Plan (ERP) as established by NFPA 72.

### **14-6.3.4 Audiometric booths**

Visual notification must be provided inside of an audiometric booth except where visual notification already being installed outside of a booth can be seen from within the booth.

### **14-6.3.5 Defend in place requirements**

Occupant notification must comply with this subsection for defend in place.

14-6.3.5.1 Private operating mode, as defined and established in NFPA 72, will be permitted to be used in all MTFs, excluding those facilities not rendering medical treatment to patients, e.g., medical warehouses, central utility plants, and telecommunication buildings.

14-6.3.5.2 Audible notification is required for all MTFs and must be provided in accordance with NFPA 72, except within Category 1 spaces (as defined in NFPA 99), such as surgical operating rooms, critical care rooms, or similar areas, where alarm activation is likely to cause injury or death to a patient.

14-6.3.5.3 Upon operation of a fire alarm initiating device, notify staff and occupants only in the zone of alarm origin via audible signaling using three-pulse temporal pattern, visible signaling, and textual signaling (where mass notification is either required or is being provided).

14-6.3.5.4 Simultaneously transmit a voice message to the rest of the building (and other buildings) as necessary in an effort to notify enough staff to respond to the zone of alarm origin. No visible appliances will be activated outside of the zone of alarm origin.

14-6.3.5.5 Subsequent activations of initiating devices in the same zone of alarm origin will not initiate any new alarm outputs but will appear at the fire alarm control unit and printer. Subsequent to the original alarm, activation of initiating devices in a different zone will initiate the audible three-pulse temporal signal and other related visual and textual signals in the new zone and will initiate a new voice message to the locations, as determined above, to identify the new location of alarm.

14-6.3.5.6 The strobes are to be installed, as outlined below, and synchronized (if necessary) within the zone in accordance with NFPA 72. Both audible and visual

signals are to be programmed to continue to operate for five minutes or until the system is acknowledged and silenced by an operator. The strobes are only to be activated in the zone of alarm origin and not in the zones where the voice message is used.

14-6.3.5.7 The voice message is to be preceded by a tone alert and must be announced with no less than three rounds of it to bring staff to the zone of alarm origin.

14-6.3.5.8 Manual operation of the voice system will override all automatic voice messages in the system.

#### **14-6.4 Smoke Detection Used in Conjunction with Smoke Compartmentation.**

Where smoke detectors are provided to hold doors open between smoke compartments, provide them on both sides of smoke compartments even though NFPA 72 allows, in some cases, such detection to be installed on one side only. Detectors must then be programmed for their respective zone to initiate the proper alarm as well as to close the door served.

### **14-7 MANAGEMENT OF SMOKE.**

Smoke management and control systems must comply with NFPA 92 and the appropriate sections of NFPA 101.

#### **14-7.1 New Smoke Control Systems.**

Zoned smoke control systems, as defined in NFPA 92, are not required for new projects.

#### **14-7.2 Existing Smoke Control Systems.**

Existing smoke control systems must comply with NFPA 92 or at the time of contractual acquisition of the system(s). Decommission zoned smoke control systems not in compliance with NFPA 92.

#### **14-7.3 Smokeproof Enclosures.**

Smokeproof enclosures are not required for high-rise facilities with health care occupancies using defend in place – see section for high-rise facilities in UFC 3-600-01.

### **14-8 WATER SUPPLY.**

See the contents in Chapter 9 Plumbing and Medical Gases for the requirements related to continuity of service in health care occupancies and ambulatory health care occupancies for water supplies.

## **14-9 INTERSTITIAL BUILDING SYSTEM (IBS).**

Comply with the related appendix in this UFC for projects incorporating IBS design concepts.

## **14-10 SPECIAL DETAILED REQUIREMENTS BASED ON USE AND OCCUPANCY.**

This section provides specific criteria for medically unique occupancies and hazards. However, when this section does not otherwise address a particular occupancy or hazard, comply with NFPA 101.

### **14-10.1 Dental Treatment Facilities.**

The following rooms are used to perform treatment or provide anesthesia, or both, which render the patient incapable of taking action for self-preservation under emergency conditions without assistance of others.

- a. Dental Treatment Room, Comprehensive [DNTC1]
- b. Dental Treatment Room, Periodontics [DNTP2]
- c. Dental Treatment Room, Oral Surgery [DNST1]
- d. Dental Treatment Room, Recovery [DNTR1] when provided in support of one of the above rooms.

When more than three of any combination of DTR chairs or recovery chairs in these rooms are located in a single facility, an occupancy classification of ambulatory health care is considered present and must be applied to either the entire facility or the portion(s) thereof containing these rooms.

### **14-10.2 Laboratories.**

Laboratories must comply with the applicable requirements of NFPA 45. Laboratories where hydrogen is used or handled must comply with NFPA 2.

#### **14-10.2.1 Hazard assessment**

In addition to the hazard of contents analysis required by NFPA 101, provide a hazard assessment of the nature of hazards in accordance with NFPA 99 or NFPA 45, as applicable.

#### **14-10.2.2 Flame spread and smoke developed indices**

Provide and document flame spread and smoke developed indices for the final interior finish installation for all walls, ceilings and floors in laboratories categorized as either Biosafety Level 3 (BSL-3) or Biosafety Level 4 (BSL-4), as established in Biosafety in Microbiological and Biomedical Laboratories, to ensure compliance with NFPA 101.

**14-10.2.3 Spot-type photoelectric detection**

Provide spot-type photoelectric smoke detection throughout the affected laboratory spaces in facilities where laboratory function protocol requires occupants to be suited, e.g., wearing positive-pressure, supplied-air protective suits.

**14-10.3 Veterinary Care and Animal Research Facilities.**

Veterinary care and animal research facilities must comply with NFPA 150. Since UFC 3-600-01 establishes that NFPA 5000 must not be used in projects for DoD, all references to NFPA 5000 in NFPA 150 are instead to be considered references to UFC 3-600-01, which identifies NFPA 101.

**14-10.4 Helipads.**

The design and construction of helipads, heliports, and helistops at (or in close proximity to) MTFs must comply with UFC 3-260-01 and NFPA 418.

**14-10.5 Pharmacy Storage.**

Storage areas, including receiving areas and main shelving spaces, for pharmacies within health care and ambulatory health care occupancies are considered hazardous areas as defined by NFPA 101. Storage area locations within the pharmacy must be separated with one-hour fire-rated construction. Where pharmacy storage space is open to dispensing or other pharmacy work areas, the one-hour fire-rated separation may be located at the pharmacy perimeter walls.

## CHAPTER 15 EQUIPMENT

### 15-1 GENERAL.

This chapter provides guidance on equipment for Military Medical Facilities, including furniture, fixtures and equipment (FF&E). Equipment procurement and installation responsibility for project planning and execution must be in accordance with MIL-STD-1691 and this chapter. These sources provide a uniform basis to identify items of construction and material, and can identify logistical and financial responsibility.

#### 15-1.1 Identification of Equipment.

The Using Agency develops a Project Room Contents (PRC) report or list using the Space and Equipment Planning System (SEPS) tool. The determination of furniture, fixtures, and equipment (FF&E) requirements must be made not later than the end of the 20% design period or final Request for Proposal (RFP) submission timeline, depending on project delivery method, and must be complete by the time the floor plan is established. Consideration to reuse medical equipment and potentially certain office furnishings are dependent on the age, condition, and remaining service life to the extent practical for the project. Decisions on equipment and furniture acquisition in support of Initial Outfitting processes must be completed as late as possible in project development but scheduled to align with facility operational milestones and project delivery method.

#### 15-1.2 Approval of Substitutions.

When design and space planning changes necessitate substitution of FF&E, the Design and Construction Agent must coordinate change details with the Using Agency. If the substitution results in a change in the Logistical Category (LOGCAT) or equipment funding source as defined in the MIL-STD-1691, the change must be coordinated with DHA/FE.

### 15-2 PROCUREMENT.

Provide equipment in accordance with MIL-STD-1691 and applicable project specific guidance. Procurement must include applicable manufacturer's literature for user operation and service. The Using Agency must determine which items of existing equipment to transfer to the new or altered facility whenever feasible and economical.

### 15-3 FUNDING CATEGORY

The Funding Category identifies the appropriation fund used to program, purchase and install building systems, FF&E and control systems in Defense Health Program (DHP) project delivery. The two funding category designations, based on property types are: "RPIE" (Real Property Installed Equipment), also referenced as "Project Funds", and "PP" (Personal Property, sometimes referred to as operational equipment), generally referenced as "Initial Outfitting and Transition" (IO&T) funds. Use of appropriations for outfitting of facilities is prescribed in Federal Management Regulation (FMR) Volume 03, Chapter 17.

## 15-4 LOGISTICAL RESPONSIBILITY.

Equipment must be procured and installed in accordance with the logistical categories as defined in the MIL-STD-1691 policy, and this document. The policy document can be found on the World Class Facility Toolkit.

The LOGCAT codes shown in Table 15-1 are used to identify procurement and installation responsibility. The responsibility column contains the acronym used to identify responsibilities of Government and Contractor relative to procurement and installation. The description column provides a definition of the LOGCAT code.

**Table 15-1 Logistical Responsibility (LOGCAT)**

LOGCAT	Responsibility	Description
A	CFCI	Contractor Furnished Contractor Installed. Equipment is purchased and installed by the construction contractor.
B	GFCI	Government Furnished Contractor Installed. Equipment is purchased or provided by the Government and installed by the construction contractor.
C	GFGI	Government Furnished Government Installed. Equipment is provided by the Government and installed by the Government (equipment vendor or agent).
D	Leased	Other. Leased or rented equipment, arranged by the Government, or any similar type arrangement requiring special funding and/or condition. Justification and approvals may be required for use of this category.
R	Reuse	Reuse. These are existing equipment assets that will be transferred and reused.

## 15-5 DESIGN.

### 15-5.1 Casework.

All built-in casework must be fabricated and designated by materials, construction methods, and fabrication that align with the highest grade quality and infection control standards for casework for use in high-performing healthcare building applications. Typical industry standards for medical/laboratory grade materiel must apply in the absence of project specific requirements/guidance.

15-5.1.1 Corrosion resistant steel (CRS) or other nonporous, seamless joint casework must be provided in these areas: operating and C-section rooms; their sub-sterile and clean-up areas; laboratory (as required by the Using Agency); central sterile supply, decontamination and clean-up areas; Autopsy and its associated clean-up areas.

15-5.1.2 Movable, modular (“systems”) casework systems may be used in projects deemed appropriate by the Using Agency.



## **15-5.2 Technically Complex Equipment and Medical System.**

Planning for and inclusion of complex medical technologies, to include but not limited to linear accelerators, positron emission tomography (PET), lithotripsy units, MRI systems, hyper and hypo baric chambers, robotic surgical systems, and automated product delivery systems, in a MILCON project is the responsibility of the Using Agency. Design must be in accordance with the appropriate Code of Federal Regulations (CFR), National Council on Radiation Protection and Measurements (NCRP) guidelines, associated non-governmental standards for unique technologies, the recommendations and guidance of the respective manufacturer, Facility Guidelines Institute (FGI) and other federal entities as applicable.

15-5.2.1 Close coordination by the Using Agency, design team, and manufacturer's technical representatives is critical to ensure staff and patient safety measures are in place, and all clinical functionality and capability is met.

15-5.2.2 When equipment or systems require shielding to minimize exposure to primary and secondary radiation, a qualified expert (medical or health physicist) who is regularly engaged in the design of radiation shielding, and certified by American Board of Radiology, American Board of Medical Physics, American Board of Health Physics, or Canadian College of Physicists in Medicine, must be included in the design team, and is the responsibility of the designer of record. The Using Agency's Health Physicist or their qualified representative must be consulted during the early planning stages to ensure all aspects of the design, both clinical and technical, are met, and shielding reports are retained by the Using Agency for audit purposes.

15-5.2.3 The Construction Contractor is responsible for the shielding system installation and integrity certification by a qualified expert (see paragraph 0). The Using Agency's Health Physicist or their qualified representative must be consulted during design and construction to ensure continuity from planning and design through final building acceptance.

## **15-5.3 Equipment Connectivity**

The project delivery team (PDT) must work closely with Health Information Technology and Logistics staff early in planning and throughout the design and construction phases to make every effort to comply with cybersecurity requirements for Facility-Related Control Systems and Medical Devices and Equipment. The design for equipment and utilities that support active and passive medical devices must comply with the Standard Isolation Architecture for Cybersecurity of Medical Devices and Equipment (MDE) as well as cybersecurity principles based on medical cybersecurity industry best practices.

## **15-5.4 Hyperbaric Medicine.**

Hyperbaric oxygen therapy is used as an adjunct to the clinical and surgical treatment of wounds and certain diseases. It consists of administering oxygen to the patient at pressures greater than 1 atmosphere (atm) in a compressed air multi-person chamber or oxygen mono-chamber. The DoD agency responsible for design requirements and

certification is the Naval Facilities Engineering Command. This agency is available to assist the Design and Construction Agent, Using Agency, and designer of record as needed. Reference UFC 4-159-01N and SS521-AA-MAN-010.

CANCELLED

## CHAPTER 16 TRANSPORTATION AND LOGISTICS

### 16-1 GENERAL.

This chapter provides guidance for the study, selection, and design of transportation and logistics systems. The chapter establishes requirements for systems including, but not limited to, elevators, escalators, dumbwaiters, material delivery equipment (automatic guided vehicles [AGVs] and Autonomous Mobile Robots [AMRs]), pedestrian traffic, service cart systems, pneumatic tube station (PTS), gravity and pneumatic chute return systems for linen and trash, and Central Material Management Systems in active Military Medical Facilities. The chapter is not intended to cover all aspects of transportation analysis or design, but rather to serve as a guide for planners, designers, and Medical Transport and Logistics Consultants (MTLCs). The elevator UFC 4-960-01, in conjunction with criteria in this chapter, establish minimum design requirements. In the event of conflict this UFC is the ruling criteria.

#### 16-1.1 Scope.

This chapter applies to horizontal and vertical circulation within Military Medical Facilities, and the transportation devices, equipment, and methodologies required for efficient, cost-effective, and timely movement of people, equipment, materials, and related materials-management logistical functions. Addition/alteration projects are to meet these guidelines to the extent practical and provide a holistic design approach in addressing correction of existing facility shortcomings.

This chapter does not prescribe when systems are required or where they should be employed. Table 16-1 prescribes when different technical analyses are required based on a facility's size; depending on the results of the analysis different transportation systems may be required. It is the responsibility of the designer of record to develop a holistic and efficient design incorporating the Using Agency's operational and functional needs.

**Table 16-1 Analysis Requirements**

Table identifies level/extent of analysis required by the type of Military Medical Facility.

Analysis	Facility Characteristic
<b>TLA</b>	Any facility >200,000 BGSF All major renovations and new construction of Ambulatory Healthcare Centers and Hospitals
<b>ETSA</b>	All facilities >1 story
<b>MMA</b>	All facilities >100,000 BGSF
<b>WMA</b>	All facilities >100,000 BGSF
Notes: Facilities include medical and dental clinics, research and laboratory buildings, Ambulatory Healthcare Centers, Hospitals, and Medical Centers.	

Analysis	Facility Characteristic
BGSF	Building Gross Square Feet
ETSA	Elevator Traffic Study and Analysis
MMA	Material Management Analysis
TLA	Transportation Logistics Analysis
WMA	Waste Management Analysis

### 16-1.2 Transportation Systems Evaluation.

For all projects requiring a Transportation Logistics Analysis (TLA) as described in paragraph 16-2.1, the Design and Construction Agent must ensure the services of a qualified MTLC are included in the request for planning and architectural services. The MTLC must be an integral part of the design team, and must be involved in every aspect of the design as it relates to transportation and logistics. This includes, but is not limited to, departmental adjacencies, vertical and horizontal circulation, facility logistics, and waste management. Refer to Table 16-1 for project analysis requirements.

The Design and Construction Agent must ensure all transportation and material handlings systems selected are procured, installed, and commissioned in accordance with design documents and applicable codes and standards.

### 16-1.3 Medical Transportation and Logistics Consultant (MTLC).

A qualified MTLC to the designer of record is an individual who has received comprehensive training and experience in the areas of materials management, food and nutrition, solid waste management, horizontal and vertical transportation, central sterile processing, and materials handling for a period of not less than five years. These services should be specific to transportation and logistics and must be documented. The MTLC must demonstrate prior experience on Military Medical Facilities that relate to the scope and nature of the project to include OCONUS locations, if applicable. The MTLC must not be involved in the sale, installation, distribution, manufacture, or representation of conveyance or material management equipment.

## 16-2 TRANSPORTATION AND LOGISTIC ANALYSIS REQUIREMENTS.

Different transportation and logistics analyses are required for facility designs as indicated in Table 16-1. These analyses must address the transportation, logistics, and waste management requirements of the project as required by this document. When required by Table 16-1, the different analyses must be submitted with the Basis of Design narratives beginning with the initial design submission and through the final design submission.

### 16-2.1 Transportation Logistic Analysis (TLA).

The MTLC must prepare a TLA in accordance with Table 16-1. The analysis must take into account total staff and patient travel times and travel distance with the objective of

minimizing both travel times and distances. This must help achieve higher staff efficiencies and lower patient environmental exposure.

16-2.1.1 The TLA must address all aspects of a facility's transportation, logistics, and waste management methodology to include but not limited to; traffic demand, vertical and horizontal travel distances, mix of traffic type in the areas to be served, mode of containerization, and items specifically addressed in the other studies. The TLA must document the following:

- a. Elevator Traffic Study and Analysis (ETSA). Reference paragraph 17-2.2.
- b. Material Management Analysis (MMA) to include a comparison of automatic vs. manual material handling systems. Automatics system include: AGVs, AMRs, PTS, and pneumatic chutes in addition to other or newer technologies. Reference paragraph 16-2.3.
- c. Waste Management Analysis (WMA). Reference paragraph 16-2.4.
- d. Life cycle cost analysis (LCCA) must be used to evaluate the alternatives and to determine the appropriate system.
- e. The MTLC must sign the TLA certifying the information contained therein is accurate, vendor neutral, and based on empirical data.
- f. The TLA must take into account the existing transportation systems and processes for addition/alteration projects.
- g. The TLA must describe in detail the MTLC recommendations to maximize the transportation and logistics efficiencies and how the recommendations are implemented into the design.
- h. The TLA must focus on defining process methodologies that optimize spatial adjacencies and minimize overall patient, staff, and material movements in design.
- i. When required by the Design and Construction Agent, the TLA must include the use of simulation to more accurately analyze and optimize departmental adjacencies and horizontal and vertical transportation solutions.

16-2.1.2 Base the TLA on:

- a. Empirical data provided by the Using Agency.
- b. Site visits to an existing facility identified by the Using Agency.
- c. Data including site constraints, Design CONOPS (including CONOPS for the logistical departments like food service, linen and waste

management, materials management, housekeeping, pharmacy, central sterile supply) and projected workload for the new facility.

- d. Elevator loading density and the load/unload time based on site visits to account for unique conditions at a facility and the cultural aspects of the area, e.g., amount of “personal space” required by individuals, number of visitors per patient, number of escorts or companions accompanying outpatients.

## **16-2.2 Elevator Traffic Study and Analysis (ETSA).**

Elevators provide the basic transportation mechanism for most vertical moves in multistory buildings. Prepare the ETSA to determine the appropriate types, locations, sizes, speeds, and groupings of elevators that result in a cost-effective and efficient operation.

16-2.2.1 ETSA Requirements. The ETSA must document the following:

- a. ETSA must be prepared by an independent elevator consultant on all Ambulatory Healthcare Centers and Hospitals.
- b. Conformance to Chapter 16, specifically paragraphs 16-3 and 16-4.
- c. A description of the elevator plant proposed, including an analysis of the walking distances, elevator types, and locations as described in paragraph 16-4.3.
- d. The population (number of working and visiting population within the facility).
- e. The number and average size of material movements within the facility.
- f. The peak hours of vertical transportation, including but not limited to: Morning Shift Change Peak (primarily a peak period in upward travel), Lunch Peak (heavy two-way traffic), Afternoon Shift Change Peak (primarily a peak period in downward travel, with moderate opposing traffic).
- g. The elevator loading densities used for each proposed elevator for working and visiting population, e.g., pedestrians, person on crutches/walker, wheelchairs, gurneys, beds, and carts. Include extra “spare capacity” when determining the aggregate elevator cab size.
- h. In determining the proposed elevator speeds provide:
  - The handling capacity calculations
  - The assumed population load/unload times

- The proposed elevator wait and response times

### **16-2.3 Material Management Analysis (MMA).**

Material must be manually moved throughout a facility unless the designer can show an automated system is physically and economically justified. The specific systems included in a project must be determined by detailed physical, functional, and economic factors including LCCA. Prepare the MMA to determine the appropriate types, locations, sizes, speeds, and design of MMA that result in a cost-effective and efficient operation.

#### **16-2.3.1 MMA Requirements.**

If the Using Agency does not require an automated system, the MMA must document such and continue no further. Otherwise the MMA must document the following:

- a. Conformance to Chapter 16, specifically paragraphs 16-3 and 16-5.
- b. Proposed automated systems including but not limited to AGV, PTS, and mobile robots.
- c. The users of the proposed systems.
- d. The number of Full-Time Equivalent (FTE) on staff for the movement of materials.
- e. Location, size, speeds of proposed systems.
- f. Specific requirements for each type of system, i.e., dry vs. wet PTS.
- g. An LCCA comparing manual movement vs. proposed alternatives.

### **16-2.4 Waste Management Analysis (WMA).**

The proper preliminary design of a Military Medical Facility waste management system requires consideration of the operational and mission characteristics of the facility, the existing waste disposal practices of the facility or base/post, the governmental regulations affecting the design, and the costs and application of system handling and disposal technologies.

16-2.4.1 Document the following in the WMA:

- a. Conformance to Chapter 16, specifically paragraphs 16-3 and 16-6.
- b. Determination of the waste stream components and soiled linen types.
- c. Estimation of waste and soiled linen volumes.

- d. Concepts for segregation, holding at the generating departments, and central bulk holding.
- e. Space, utility and life safety requirements for departmental holding rooms.
- f. Concepts for collecting and transporting waste and soiled materials within the facility.
- g. Soiled dock arrangement, layout, and equipment.
- h. Waste Management Center (WMC) space, layout, equipment, and support utility requirements.
- i. Concepts for the disposal of each waste category.
- j. Proposed Waste Management Systems including, but not limited to, gravity chutes and pneumatic trash/linen systems.
- k. Life-cycle costing studies including Regulated Medical Waste (RMW) processing equipment.
- l. Aspects of RMW processing; O&M, safety, infection control.

**16-3 FACILITY DESIGN.**

Transportation and logistics requirements must be integrated into the overall facility design. Design the overall floor plan and circulation to provide the most direct routing practical. Separate different types of traffic as required in paragraph 16-3.1. Utilize transportation systems as determined by Table 16-1.

**16-3.1 Traffic Separation.**

Establish traffic patterns to separate the various traffic types in an efficient, logical, safe, and secure manner, while maintaining levels of aseptic control consistent with the requirements of the facility. Consider all of these factors for separation for horizontal and vertical circulation: patient privacy; accessible access; aseptic control; routing efficiency; utilization of appropriate hardware systems, safety, and security. Where circulation conflicts occur, prioritize traffic as listed here:

- a. Patient
- b. Staff
- c. Equipment
- d. Visitors
- e. Materials/logistics (may be combined use – supply elevators with staff)



### 16-3.2 Transportation Systems.

The designer of record must consider traffic demand, vertical travel distance, mix of traffic type in the areas to be served, and mode of containerization. Traffic demand and vertical travel distance must determine equipment type and speed required. Traffic mix and mode of containerization must determine load capacity, platform size, configuration, and door type.

### 16-3.3 Vertical Automation.

Systems designed exclusively for vertical only transportation of materials on carts must use elevators, guide path, and other devices, as applicable. Designs must consider future upgrade to allow horizontal travel.

### 16-3.4 Equipment/Materials Separation.

Separate the equipment/materials traffic from patient and visitor traffic as noted on the Elevator Traffic Separation Guide, Table 16-2. Where separate elevators are not required, separate the materials traffic by schedule and policy. Careful, simple, and clear space planning can maximize separation between visitor/patient and staff/materials/logistics. Primary horizontal materials circulation should occur on a single level, with vertical penetrations that are convenient to heavy use areas. It is undesirable for AGVs, carts, pallet trucks, and similar material carriers to be moved long distances on floors and corridors routinely traveled by patients or visitors. For example, it is preferred to use two (or more) single elevators in distributed areas if traffic needs dictate more than one service/AGV elevator is required.

**Table 16-2 Elevator Traffic Separation Guide**

Purpose: Table presents recommended arrangement of elevators by Medical Military facility configuration and mission.

Analysis	Facility Characteristic
Combine all elevators regardless of function	All facilities <50,000 BGSF
Combined and separated elevators acceptable	All facilities <200,000 BGSF
Separate Passenger Traffic. Separate Inpatient Traffic. Separate Logistics/Materials Traffic.	All facilities >200,000 BGSF All Ambulatory Healthcare Centers, Hospitals, and Medical Centers regardless of size
Notes: The decision to separate or combine any elevator function must be supported in the ETSA.	

### **16-3.5 Clean and Soiled Material Separation.**

Materials management programs must provide for clean and soiled separation consistent with all applicable codes and standards, including those of TJC.

#### **16-3.5.1 Soiled Material.**

Soiled materials are normally transported in separate covered or closed carts designed to provide containment of the material and to maintain infection control. Soiled material transport may occur in the same corridor and elevator systems that handle other traffic. However, soiled materials are not transported on the same elevator at the same time with patients, visitors, or clean or sterile materials. Transport circulation design must allow soiled carts to be properly washed prior to reuse as a soiled container and washed and sanitized prior to use for transporting clean materials.

#### **16-3.5.2 Sterile Material.**

Transport all sterile material for use in Surgery, Catheterization, and Labor/Delivery or other areas requiring sound aseptic controls from the sterile processing/storage area to its destination via a clean route that must not compromise the integrity of the material. Where case carts are used, they must be transported from sterile storage to the clean surgical core by means that protect the cart and its contents from contact with less clean environments.

### **16-3.6 Escalators.**

Consider escalators for pedestrian traffic where justified by traffic studies. Consider escalators for frequent vertical movement of large numbers of people in multi-floor outpatient clinics that exceed 2000 patient visits per day. Escalators are not subject to analysis or criteria measurements for average intervals. Design escalators to handle large numbers of pedestrians in a safe and efficient manner. Designs must consider that traffic must include persons who may be slightly impeded by physical disabilities or by virtue of medical/pharmacological treatment. Design escalators with safe travel speeds and adequate entrance and exit queuing areas to handle the expected volumes. Escalators must be designed in accordance with all applicable codes, including the IBC and ASME A17.1, A17.3, and A17.5.

## **16-4 ELEVATOR DESIGN.**

All multistory facilities must have at least two elevators. The ETSA must include a risk assessment to determine if at least one must be sized to accommodate a gurney. All multistory inpatient and surgical facilities must have not less than two elevators sized to accommodate a gurney.

### **16-4.1 Codes.**

Elevators must be designed in accordance with all applicable Federal, state and local codes, including ASME A17.1, A17.3, 17.5, and elevator design requirements for earthquake/seismic loads in accordance with ASCE 7. This includes designing to the

appropriate rating/load classification for the intended application. Elevators must be designed to meet all DoD and ABA provisions applicable to the project.

#### **16-4.2 Elevator Selection.**

Military Medical Facilities use elevators for three major functions: passenger movement, service/staff movement, and logistics. Passenger elevators are intended for use by the public. Service/staff elevators are intended for use by staff movement and for the transport of bed-bound inpatients. Dedicated patient assist/trauma elevators are intended for patient transport from Critical Care Areas, i.e., ER trauma rooms, to the ORs. Logistics elevators are intended for use by staff for material and equipment movement. Where allowed by Table 16-2, a single set of elevators can serve multiple functions. All elevators must meet the following:

16-4.2.1 Elevator types and speeds guidelines are shown in Table 16-3, Elevator Selection Guide. Higher speeds may be used if needed to satisfy traffic demands. Elevator selections must not exceed the elevator rise criteria given in Table 16-3.

16-4.2.2 Service elevators within an inpatient facility must have interior dimensions that accommodate a patient bed with attendants. Cars must be at least 5 feet 8 inches wide by 9 feet eight inches deep. Car doors must provide a minimum clear opening of 4 feet wide and 7 feet high. All other elevator dimensions must meet the requirements of Tables 16-4 and 16-5.

16-4.2.3 In renovations, existing elevators that can accommodate patient beds used in the facility must not be required to be increased in size. Other existing elevators may need to be resized depending on the results of the ETSA.

16-4.2.4 Front and rear opening hospital elevators may be used as combined use for passenger and service/staff traffic when space or budget restrictions limit use of separate passenger elevators.

16-4.2.5 When allowed by Table 16-3, hydraulic elevators rated for 80 starts per hour must be utilized for light duty/light usage applications. Hydraulic elevators rated for 120 starts per hour must be utilized for heavy duty/heavy usage applications.

**Table 16-3 Elevator Selection Guide**

Table presents recommended minimum elevator types and performance parameters by elevator travel distance.

Elevator Rise		Speed (Feet / Minute)				Capacities (Pounds)	
Stops	Travel Distance (feet)	Hydraulic	MRL	Geared Traction	Gearless Traction	Passenger	Service
2	<16	125	NA	NA	NA	4000 <sup>(2)</sup>	5000 <sup>(3)</sup>
3-4	32-48	150	350 <sup>(4)</sup>	200 <sup>(4)</sup>	NA	4000 <sup>(2)</sup>	5000 <sup>(3)</sup>
5-10	64-144	NA	350 <sup>(1) (4)</sup>	350 <sup>(4)</sup>	NA	4000 <sup>(2)</sup>	5000 <sup>(3) (5)</sup>
11-17	160-256	NA	350-500 <sup>(1) (4)</sup>	350 <sup>(4)</sup>	500 <sup>(4)</sup>	4000 <sup>(2)</sup>	5000 <sup>(3) (5)</sup>
18+	272	NA	NA	NA	500-700 <sup>(4)</sup>	4000 <sup>(2)</sup>	5000 <sup>(3) (5)</sup>
Notes:							
MRL – Machine room-less							
NA – Not allowed							
1.	This table must generally identify the type of equipment and the associated speed based solely on the Rule of Thumb of the height of the building.						
2.	Wide Car configuration used with separate passenger and service elevators.						
3.	Deep Car configuration used with service and combination elevators.						
4.	Application to be determined by elevator consultant in preparation of ETSA.						
5.	6,000 pound capacity minimum required if facility has motorized beds or as determined by the ETSA.						

**Table 16-4 Elevator Dimension – Front Openings Guide**

Table presents minimum hoist way and elevator dimensional parameters for front opening elevator types.

Capacity	Hostway Width	Hostway Depth	Clear Interior Width	Clear Interior Depth	Clear Door Width	Clear Door Height	Door Type <sup>(5)</sup>
6,000 pounds Deep	9 feet 1 inch	11 feet 5 inches	6 feet 0 inches	9 feet 8 inches	5 feet 0 inches	7 feet 0 inches <sup>(3)</sup>	Single Speed Side Opening or Center Opening
5,000 pounds Deep	8 feet 2 inches	10 feet 1 inch	5 feet 8 inches	8 feet 5 inches	4 feet 6 inches	7 feet 0 inches <sup>(3)</sup>	Single Speed Side Opening or Center Opening
4,500 pounds Deep	8 feet 2 inches	9 feet 6 inches	5 feet 8 inches	7 feet 9 inches	4 feet 0 inches	7 feet 0 inches <sup>(3)</sup>	Single Speed Side Opening
4,000 pounds Deep	8 feet 2 inches	9 feet 0 inches	5 feet 8 inches	7 feet 3 inches	4 feet 0 inches	7 feet 0 inches <sup>(3)</sup>	Single Speed Side Opening
4,000 pounds Wide	9 feet 4 inches	7 feet 8 inches	7 feet 8 inches	5 feet 5 inches	4 feet 0 inches	7 feet 0 inches <sup>(3)</sup>	Center Opening
Notes:							
1.	All dimensions are for non-seismic zone.						
2.	All dimensions do not include counterweight safeties.						
3.	8 feet 0 inches also available.						
4.	Elevators dedicated only to AGV system operation (not shared with people) must be minimum 4 feet 0 inches clear door width, minimum 5 feet 0 inches clear interior width, minimum 8 feet 5 inches clear interior depth, and allow for a maximum single AGV wheel load of 1,050 pounds, except for fork style AGV, which requires minimum 10 feet 7 inches clear interior depth and has maximum single AGV wheel load of 1,150 pounds. Minimum capacity for AGV system-dedicated elevators must be 4,000 pounds.						
5.	Provide Center opening doors.						

**Table 16-5 Elevator Dimension – Front and Rear Openings Guide**

Table presents minimum hoist way and elevator dimensional parameters for front and rear opening elevator types.

Capacity	Hostway Width	Hostway Depth	Clear Interior Width	Clear Interior Depth	Clear Door Width	Clear Door Height	Door Type <sup>(5)</sup>
6,000 pounds Deep	9 feet 1 inch	12 feet 4 inches	6 feet 0 inches	9 feet 8 inches	5 feet 0 inches	7 feet 0 inches <sup>(3)</sup>	Single Speed Side Opening or Center Opening
5,000 pounds Deep	8 feet 2 inches	10 feet 11 inches	5 feet 8 inches	8 feet 6 inches	4 feet 6 inches	7 feet 0 inches <sup>(3)</sup>	Single Speed Side Opening or Center Opening
4,500 pounds Deep	8 feet 2 inches	10 feet 4 inches	5 feet 8 inches	7 feet 10 inches	4 feet 0 inches	7 feet 0 inches <sup>(3)</sup>	Single Speed Side Opening
4,000 pounds Deep	8 feet 2 inches	9 feet 10 inches	5 feet 8 inches	7 feet 4 inches	4 feet 0 inches	7 feet-0 inches <sup>(3)</sup>	Single Speed Side Opening
4,000 pounds Wide	9 feet 4 inches	7 feet 4 inches	7 feet 8 inches	5 feet 5 inches	4 feet 0 inches	7 feet-0 inches <sup>(3)</sup>	Center Opening
<b>Notes:</b>							
1.	All dimensions are for non-seismic zone.						
2.	All dimensions do not include counterweight safeties.						
3.	8 feet 0 inches also available.						
4.	Elevators dedicated only to AGV system operation (not shared with people) must be minimum 4 feet 0 inches clear door width, minimum 5 feet 0 inches clear interior width, minimum 8 feet 5 inches clear interior depth, and allow for a maximum single AGV wheel load of 1,050 pounds, except for fork style AGV, which requires minimum 10 feet 7 inches clear interior depth and has maximum single AGV wheel load of 1,150 pounds. Minimum capacity for AGV system-dedicated elevators must be 4,000 pounds.						
5.	Provide Center Opening Doors.						

### **16-4.3 Elevator Location and Travel Distances.**

Elevators must be designed, arranged, and placed within the building to; minimize patient/staff travel distance and time, provide convenient access to healthcare delivery services, and provide cost-effective elevator performance (direct capital cost of elevators, indirect cost of the space dedicated to their function, and O&M are major cost components of any building). The desired walking distance from the elevator doors to the center point of the farthest occupied room should not exceed 200 feet. This factor must be weighed along with the advantages of elevator accessibility, locating elevators centrally, elevator clustering, and medical functionality. The A/E must provide a description of the elevator plant proposed, including an analysis of the walking distances, elevator types, and locations for evaluation. The Using Agency, in coordination with the Design and Construction Agent, must evaluate the proposed elevator plant to determine if proposed travel distances from elevators to healthcare delivery services and administrative areas are acceptable based upon the mission, population served, and operational concepts.

Additional elevators may be required based upon an assessment by the Using Agency in coordination with the Design and Construction Agent. These elevators must be in addition to the main elevators provided for efficient and effective travel throughout the building. These elevators are intended for staff convenience only, thus should be located away from main thoroughfares and should not be located where they must interfere with clinical activities. These elevators must provide average intervals of under 55 seconds and must provide a handling capacity equal to 7.5 percent of the population within the area of service provided. Cars added for this purpose must be service configured and be access controlled by staff.

### **16-4.4 Elevator Location, Lobbies, and Groupings.**

Placement of elevators must meet the travel distance requirements of paragraph 16-4.3, Material and traffic separation of paragraphs 16-3.1 through 16-3.5 while considering the requirements of paragraph 16-4.4.1 through 16-4.4.3.

#### **16-4.4.1 Elevator Location.**

Place elevators on the direct horizontal path between the areas they serve, wherever possible. Locate elevators so that visitors do not normally pass service, material, or convenience cars en route to passenger cars, unless those cars are substantially hidden from view. Consider operational impacts such as noise, vibration, temperature, and other environmental factors when adjacent to critical treatment areas or those having sensitive equipment. Place adjacent car entrances either in straight lines or in opposite banks to each other.

Where AGV systems are used that require more than one elevator, single elevators must be distributed to minimize horizontal travel on patient floors. On the service levels, consideration should be given to open both sides to allow drive-through capability to achieve higher throughput. On the patient floors, there must be two openings (front and rear) into secure access AGV lobbies/vestibules used for the primary purpose of

temporary staging, picking up, and delivering carts. Adequate space inside these lobbies should be coordinated with AGV system vendors prior to finalizing the design.

#### **16-4.4.2 Elevator Lobbies.**

Elevator ingress/egress should be from a distinct elevator lobby and not directly from a corridor. Minimum/maximum lobby depth for service cars are 12–14 feet when the opening opposes a wall and 14–16 feet when the opening opposes another elevator. Minimum/maximum lobby depth for passenger cars are 10–12 feet when the opening opposes a wall and 12–14 feet when the opening opposes another elevator.

16-4.4.2.1 Where elevators are accessed from corridors, they must be located on one side of the corridor only with a maximum of three cars. Elevators must be set back 8–12 feet for service and combined use cars and 4–8 feet for passenger cars.

16-4.4.4.2 Where two or more elevator group lobbies are adjacent, provide walls or other building features to prevent a free flow of traffic between those lobbies (to minimize one user from placing calls to both groups). Where Table 16-2 requires separation of elevators, passenger elevators must not share the same lobby with service and logistics elevators. Acoustically isolate all elevator lobbies from Critical Care Areas.

#### **16-4.4.3 Elevator Groupings.**

For service and combined use cars, two in a row are preferred and not more than three in a row should be used; for passenger cars three in a row are preferred and not more than four in a row should be used.

If more than six service cars or eight passenger cars are required in one area, provide two smaller, strategic groups.

#### **16-4.5 Passenger and Service Elevator Features.**

Passenger and service elevators must meet the requirements of the subparagraph below.

##### **16-4.5.1 Operation.**

Elevators must be arranged to operate with or without attendants and must be provided with key operated switches for hospital priority service. Each elevator bank must be equipped for emergency operation by means of a key operated switch at each landing. This switch must cause the closest available car to bypass all other calls in response to an emergency call. Duplex collective operation must be provided for two-car banks. Three- or four-car banks must be a group operation. An on-demand microprocessor system must be provided for all elevator controls.



#### **16-4.5.2 Code Blue Controls.**

Provide medical emergency elevator control, sometimes called Code Blue Control, as a means of overriding normal operation of elevators capable of medical emergency transportation of a patient in bed, accompanied by attendants. This control feature must be provided in conjunction with, or in addition to, controls provided for fire department emergency use. Firefighters' operation, as defined in ASME A17.1, must override Code Blue Control.

#### **16-4.5.3 Doors.**

Passenger and service elevators must have center opening doors. Two-speed side opening doors may be provided in facilities with separate material handling systems (reference Table 16-2). Door closing time must comply with ASME code requirements. Minimum door opening speed must be 2.5 feet per second except for high speed elevators (500 feet per minute and over) where the door opening speed must be 2.5–3.0 feet per second. Equip service elevators with buttons to extend door open time, adjustable between 0 to 30 seconds. All elevator car doors must be provided with infrared screen detectors.

#### **16-4.5.4 Signals.**

Install hall position indicators at the main floor(s) containing the command and outpatient entrances. Provide hall push-button stations with call register lights. Install hall lanterns with an audible signal on all elevators. Install car position indicators in each car with floor designations, a floor directory signal, and direction arrows. Car operating panels must use car register-type floor buttons. Provide a lobby control panel on elevator banks with two or more cars.

#### **16-4.5.5 Emergency Power.**

When otherwise required, connect elevators to operate on alternate source emergency power in conformance with electric power and lighting criteria. Emergency power selection switches are required for each bank of elevators. The elevator control system must have an ATS which returns each elevator to the main egress level, one car at a time. The last car to arrive at the main floor must automatically be selected to operate at normal design speed.

During an emergency power condition, ASME A17.1 requires all groups of elevators, which are supplied with an alternate power source, to automatically sequence one at a time to the main egress level. Once all cars have reached the designated level, the elevator system must automatically select one car within the group to operate. A manual override switch must also be provided, so emergency personnel may select a particular car if desired.

#### **16-4.5.6 Machine Rooms, Control Rooms and Machinery Spaces.**

Locate electric traction elevator machine rooms above elevator hoist ways. Machine rooms must be sized to accommodate the maximum space requirements anticipated

from competitively bid projects, including provisions of space to service and maintain equipment, as well as any additional DoD required equipment and functions including, but not limited to emergency descent to fire fighters' designated level for elevators that are not served by an emergency generator. In the event of a flood zone location, the Machine Room can be located on the first floor above the flood zone. Provide air conditioning in machine rooms to maintain ambient temperature below 85 degrees F and above 60 degrees F. Provide filters to remove dust. Size hydraulic elevator rooms accordingly for the equipment, place them adjacent to or at least within 50 feet of the elevator, and on the lowest served floor. Electrically and acoustically isolate all elevator equipment rooms to prevent interference with building electronic equipment and objectionable noises.

Machine room-less (MRL) systems are allowed where deemed appropriate by the Design and Construction Agent in coordination with the Using Agency. Follow UFC 3-490-06 requirements for elevator control rooms and elevator machinery spaces.

#### **16-4.5.7 Elevator Car Enclosure.**

Car lighting must be either indirect or of the luminous ceiling type. Provide mechanical exhaust for elevator cars. Provide protective cab interior blanket hooks and one set of full-height blankets per cab.

#### **16-4.5.8 AGV System Elevator Features.**

When determining elevator usage requirements for AGV systems, consideration must be given to whether the elevator must be dedicated for exclusive use of the AGV system. The elevator must be dedicated to sole use by the AGV system if the AGV system requires greater than 50–60 percent of any single elevator. If the AGV system usage is less than 50–60 percent of the elevator, then the AGV/elevator interface must allow for a manual mode of operation to accommodate other material conveyances.

16-4.5.8.1 For shared (automatic and manual) use elevators, the AGV system must release the elevator for manual movements when all automatic transports have been completed. The AGV system must request automatic mode when needed and the elevator controls must disable hall call buttons and flash "Elevator in Automatic Mode" warning signs in the halls. After all cabin calls are answered and the doors close, the elevator must change from manual mode to automatic mode. The specific signals and sequencing of them for AGV/elevator interface must be specified by the AGV system vendor after selection and the elevator supplier must conform to it as well as maximum leveling and gap tolerances. Fire service level and alternate fire service levels must be identified in the TLA.

16-4.5.8.2 Shared Mode Elevators must include flashing lights with the words "Elevator in Automatic Mode" on all landings to indicate when the AGV system has requested use of the elevator. A flashing sign with audible warning must activate inside the cabin after the elevator doors have closed, there are no more cabin calls, and the elevator control changes from manual mode to automatic mode.

16-4.5.8.3 The elevator controls must include an AGV system interface terminal strip to which discrete, potential free contacts rated for 24 volts are wired in the machine room. Supporting elevator software/logic must control the contacts inputs and outputs (I/O) in accordance with a specification to be provided by the selected AGV system vendor. A manual key switch for entering automatic mode must be located in the elevator cabin.

16-4.5.8.4 Each AGV system elevator controller must have discrete I/O terminals to receive and transmit.

16-4.5.8.5 AGV elevator doors must have switches on each door to signal when the doors are completely closed as well as completely open so as not to restrict the clear opening. Leveling circuitry must be incorporated to prevent signaling the arrival of the cabin to a floor when the cabin is not within the leveling tolerance.

## **16-5 MATERIAL MANAGEMENT DESIGN.**

### **16-5.1 AGV Systems.**

Design the AGV systems to incorporate the latest state-of-the-art in proven technology; systems not proven in at least five previous similar applications must be avoided. System must be an integrated turnkey automated cart transportation system.

AGV systems may utilize a variety of transportation vehicles (transporters) including “cart carrying” type and forklift type; towing type transporters are not desired because they do not transport carts with the casters off the floor.

#### **16-5.1.1 Design.**

The design must establish horizontal rights-of-way to:

- a. Aid in directing traffic to the appropriate vertical core, while avoiding inappropriate elevators and other building areas;
- b. Provide high levels of patient privacy and protection from high noise levels; and
- c. Eliminate potential contamination of clean and sterile areas.

#### **16-5.1.2 AGV Elevators.**

The elevators that provide vertical transport for AGVs must open into enclosed pickup and delivery (P&D) lobbies with motorized door access to the main circulation corridors on the patient floors. Consider two vestibules—one accessible from each elevator door—for separate soiled and clean cart staging areas. Where higher cart transport volumes exist, a path must be included for AGV vehicle travel from the clean side to the soiled side without having to use the elevator cabin. Recommendations for positive/negative air pressure or motorized doors between these areas must be included.

## **16-5.2 Pneumatic Tubes.**

16-5.2.1 Provision of PTSs must be consistent with requirements for a particular Military Medical Facility regardless of the size of the facility. No specific correlation can be made between the number of beds in a Military Medical Facility and the need for a PTS. Facility parameters and FTE usage are the primary drivers for the use of pneumatic tubes.

16-5.2.2 Design systems to reach individual project peak traffic requirements, plus a minimum spare capacity of 20 percent. Designs must provide for soft handling of all systems where laboratory specimens and other delicate items are transmitted.

16-5.2.3 Select tube systems that provide automatic control of carrier movement. A selector device that permits correspondence with any station served by the system must set the destination of the carrier.

## **16-5.3 Mobile Robots.**

Mobile robots must be considered only when they have been proven in other similar applications in at least five similar hospitals and can be considered for travel through any corridor to nursing units and to patient rooms.

Mobile robots that interface with elevators must use a similar interface method to the AGV system interface described elsewhere. Mobile robot travel must be segregated from AGV system traffic routes and AGV elevators unless they use the same control system.

## **16-5.4 Dumbwaiters and Cart Lifts.**

Dumbwaiters must meet the requirements of the following subparagraph.

### **16-5.4.1 Dumbwaiters, Counter Height.**

Automatic loading and unloading must be considered. Dumbwaiters without automated devices must have powered or manual doors. Powered doors must be vertical lift type and have upper and lower safety edges.

### **16-5.4.2 Dumbwaiters, Floor Loading.**

Automatic loading and unloading must be considered. Floor loading dumbwaiters must have powered vertical lift bi-parting doors with upper and lower safety edges.

### **16-5.4.3 Dumbwaiter Platform Size.**

Dumbwaiter systems must be limited to a maximum platform size of 9 square feet and maximum capacity of 500 pounds. A platform size of 27 by 48 inches is acceptable. Automatic loading and ejection devices of larger capacity and size, used in conjunction with automatic cart lifts, must conform to the ASME standards for elevators. Determine

the dimensions of the car lift platform by the largest cart selected for dietary, linen, or other materials distribution.

**16-5.4.4 Automatic Cart Lifts.**

Speeds for lifts are as listed here:

Number of Floors	Type of Drives	Rated Speed (feet per minute)
4–5	Geared	200
6–9	Geared	300
10 and over	Gearless	500

**16-5.4.5 Dumbwaiter and Cart Lift Control.**

Distribution and return programs must be provided for dumbwaiter and cart lift operation. The control station must contain a switch for program selection and a series of dispatch buttons that correspond to the floors served. Design the system to permit dispatching carts to any landing from the central dispatching area and to provide for return of carts only to the central dispatching area.

**16-5.4.6 Dumbwaiter and Cart Lift Signals.**

Stations at each floor or landing must contain lights to indicate which program is in effect.

**16-5.4.7 Cart Lifts with Automated Transfer Devices.**

Doors must be power operated with upper and lower safety edges. Maximum cart lift capacity must be 1,000 pounds.

**16-6 WASTE MANAGEMENT DESIGN.**

The waste management system must be designed to help maintain aseptic environments in the hospital, and to minimize or eliminate physical and infection hazards to patients, hospital staff, and the general public, at the lowest LCC to the Government. The design objectives should include hazardous waste optimization/process improvements, recycling, waste minimization, and hazardous material substitution to more environmentally friendly products/processes.

**16-6.1 Waste Categories.**

The categories of Military Medical Facility waste are: Regulated Medical Waste (RMW), Hazardous Waste (HW), Recyclable Materials (RM), and general waste. Each of the categories of Military Medical Facility waste requires individual design consideration of handling, storage, and disposal by the facility. In addition, regulatory requirements differ for each category dependent upon the geographic location (state or country), relative personnel and public hazards and environmental impact.

## **16-6.2 Waste Collection and Transport.**

The waste management system must be fully coordinated with the transportation design to determine the most appropriate means and routing of transport of wastes inside and outside of the facility. Consideration should include: regional waste collection service provider to account for dumpster sizes (usually provided by the Installation / DPW); dumpster loading/unloading offsets; and minimum turning radius of waste removal trucks. Automatic or manual systems should be considered. The design must avoid creating conditions that require or involve the double-handling of waste, especially RMW and HW.

16-6.2.1 Where facilities receive palletized supplies, designate an exterior area for the storage of empty/idle pallets waiting for disposal.

16-6.2.2 Provide easy access to dumpsters from back-of-house materials management/waste management areas. If dumpsters are located at a distance from the facility due to ATFP or other reasons ensure ramps or other means are provided to allow the transport of wheeled trash carts from the facility to the dumpster.

16-6.2.3 Supply and loading dock areas should be provided with overhead weather protection by either a canopy or overhang.

16-6.2.4 If Nuclear Medicine, Decay Storage (NMDS1) and Nuclear Medicine, Decay Calibration (NMDC1) rooms are included in the Program For Design (PFD), coordinate the location with the Using Agency and identify the path of travel to meet 10 CFR 35.92, 10 CFR 20.1201, and 10 CFR 20.1301.

## **16-6.3 Regulations, Codes, and Standards.**

The preliminary design of the waste management system must comply with all applicable Federal, state, and local codes and regulations, including: Nuclear Regulatory Commission (NRC) guidelines; NFPA 82; 40 CFR 261–265 and 40 CFR Part 22; 49 CFR 171–180; 29 CFR 1910.1200, 29 CFR 1910.1030, and 29 CFR 1910.134. Guidelines and advisory standards available from the NFPA, the CDC, National Institute for Occupational Safety and Health (NIOSH), Department of Health and Human Services (HHS), and TJC must be utilized as applicable and considered minimum criteria for facility design. The WMA must be based on regulations and standards enforced by the local authority.

## **16-6.4 Gravity Chutes.**

16-6.4.1 Gravity chutes must comply with NFPA 82 unless otherwise modified herein.

16-6.4.2 Consider gravity chutes either alone or in combination with horizontal pneumatic chutes, for internal general and soiled linen transportation (down only) in multistory institutions. Also, consider hospital service elevators, AGVs, and cart lifts for internal transportation of solid wastes in multistory buildings. Consider that the AGV

system has to move empty linen carts down from patient areas and these movements can be used for transport of soiled linen at very little, if any, incremental cost.

16-6.4.3 Collection areas for soiled linen must be located near the loading dock.

16-6.4.4 Provide chute access on user levels through a separate room with dimensions adequate for holding the collection cart, with room doors closed, while the attendant is charging the chute.

16-6.4.5 Size terminal rooms to accumulate the amount of materials dictated by the WMA. Minimum dimension must allow accumulation of 24 hours of collected materials. Design must ensure that collected material does not block the entrance door or hinder the pickup operation.

16-6.4.6 Masonry waste chutes are prohibited. Refractory lined chutes are prohibited. Automatic sprinklers are required in all chutes regardless of construction.

16-6.4.7 Vertically aligned charging doors of the same chute system must be interlocked so that only one station can be charged at one time, thereby reducing the possibility of charges jamming within the chute. Provide gravity chutes with negative pressure, relative to the charging area, to eliminate aerosol discharged into the charging areas when charging doors are opened.

## **16-6.5 Pneumatic Trash/Linen.**

16-6.5.1 Pneumatic trash/linen systems must comply with NFPA 82 unless otherwise modified herein.

16-6.5.2 Pneumatic trash/linen systems must be fully pneumatic, gravity pneumatic, or multi-loading. Hybrid systems are permitted where required. In general, no station must be designed that is "up-send" in nature. All materials should travel in the down direction after first being loaded into the system. Verify system traffic capabilities by detailed traffic studies.

16-6.5.3 Gravity-pneumatic systems, a combination of gravity chutes for vertical transportation, and pneumatic chutes for horizontal transportation are subject to the same fire protection requirements as gravity systems.

16-6.5.4 In composite systems, the gravity chute must be equipped with a storage section at the bottom of the chute. Gravity chute charging stations equipped with electric control systems may be loaded with as many bags of waste or linen as necessary. Bags are accumulated in the storage section and are removed as a single load on demand.

16-6.5.5 Fully automatic chute systems containing horizontal and vertical elements, with automatic transfer systems, are not normally allowed in Military Medical Facilities. Where a vertical rise is required for a pneumatic chute intended as a collector for gravity chutes, the vertical rise must be installed in a fire-rated enclosure in accordance with NFPA 82.

16-6.5.6 If horizontal pneumatic chutes must be manually charged, enclose charging doors and frames in fire-rated rooms. Sprinklers in the charging stations must protect pneumatic chutes. Charging stations must have a receiving compartment with an outer and inner door. When the door is opened to put in a load, the inner door must be automatically locked so that the load cannot freely enter the chute. When the outer door is closed, the inner door must open in its sequential turn and the load must be automatically transported by negative pressure to its point of discharge. Only one load must move through each leg of a pneumatic chute system at one time.

CANCELLED



## CHAPTER 17 CONSTRUCTION

### 17-1 CONTRACT AWARD.

DHA/FE will provide authority to the Design and Construction Agent to award a construction contract in accordance with Chapter 3 Design.

### 17-2 COMMISSIONING DURING CONSTRUCTION.

Reference Chapter 19 Commissioning.

### 17-3 CONSTRUCTION CONTRACT CHANGES.

#### 17-3.1 Process for Reporting Changes.

17-3.1.1 For projects assigned to USACE, proposed project changes impacting unique medical technical criteria covered under this document must be coordinated with the CEHNC-EDX for their comment and recommendation.

17-3.1.2 For projects assigned to NAVFAC HQ MFDO, they have responsibility for changes as they require and deem appropriate.

17-3.1.3 For projects in the United Kingdom, the AFCEC has responsibility for changes as they require and deem appropriate.

#### 17-3.2 Process for Approving Funds.

Changes must be submitted for approval to the designated Design and Construction Agent (USACE, NAVFAC HQ MFDO, or AFCEC/CFM) in accordance with their established business practices. All discretionary changes must be submitted in accordance with Using Agency policy.

### 17-4 CONSTRUCTION FUNDS.

#### 17-4.1 Funds Management.

DHA/FE will sub-allocate all of the appropriated design and construction funds to the Design and Construction Agent who must manage the funds at the project level.

#### 17-4.2 Funds Availability.

If funds are required for changes that exceed the amount available and the authorized contingency is inadequate, the Design and Construction Agent must notify and request additional funds from DHA/FE in writing, along with justification for additional contingency funds, and cite source of funds. The Design and Construction Agent must notify DHA/FE if actual requirements exceed the appropriated amount.

**17-5 CONTRACTOR CLAIMS.**

**17-5.1 Notification.**

The Design and Construction Agent must notify DHA/FE and the Using Agency of submitted contractor claims that have been approved by the Contracting Officer or the Board of Contract Appeals within 30 working days of date of the determination to reimburse the contractor for claims that require additional funding. Such claims must be accompanied with a narrative explanation, recommended resolution, and estimated final cost.

**17-6 LIFE SAFETY CERTIFICATION.**

**17-6.1 Life Safety Assessment**

Refer to Chapter 14 Fire Protection and Life Safety for LSA requirements.

**17-7 DEMOLITION OF VACATED FACILITIES.**

The demolition of vacated facilities must be reported on the project DD Form 1354 in accordance with UFC 1-300-08.

CANCELLED

## CHAPTER 18 BUILDING INFORMATION MODELING (BIM)

### 18-1 GENERAL.

BIM is an enabling tool for facilities projects within the MHS to more effectively achieve current requirements described throughout this document and assist the MHS in achieving fundamental Facility Life Cycle Management (FLCM) requirements in supporting the delivery of Military Medical Facilities.

#### 18-1.1 BIM Objectives.

The MHS BIM objectives are to support:

- a. Clarify level of detail/development (LOD) understanding and expectations within the model and respective deliverables.
- b. PFD validation to actual design/construction.
- c. Project Room Contents (PRC) validation.
- d. Defense Medical Logistics Standard Support (DMLSS) Facilities Management integration.
- e. DMLSS Medical Equipment integration.
- f. Energy modeling efforts.
- g. Effective simulation of healthcare operations.
- h. Effective planning and programming analysis.
- i. Effective Initial Outfitting and Transition (IO&T) efforts.
- j. Effective interoperability across the FLCM.

#### 18-1.2 Minimum BIM Standards.

To ensure these objectives are uniformly achieved, all projects are required to implement the MHS BIM Minimum Requirements established for projects funded, or to be operated and maintained, under DHP funds. This applies to all projects CONUS or OCONUS, except Unspecified Minor Construction (UMC). The MHS BIM Minimum Requirements are located at <http://facilities.health.mil/repository/getfile/1463>.

*This Page Intentionally Left Blank*

CANCELLED

## CHAPTER 19 COMMISSIONING

### 19-1 GENERAL.

This chapter addresses the Total Building Commissioning (TBCx) requirements and the process to be implemented as required by Federal regulations and the *Federal Leadership in High Performance and Sustainable Buildings Memorandum of Understanding*.

Upon receipt of DA for A/E Award, the Design and Construction Agent and Using Agency must jointly determine the commissioning leadership structure and the extent and the level of commissioning services required during all project phases as appropriate for the specific project; this must be communicated in the project requirements documents.

### 19-2 SUPPLEMENTAL CRITERIA.

Guidance for the Commissioning process is contained in UFC 1-200-02, ASHRAE 189.1, ASHRAE/NIBS commissioning guidelines included in ASHRAE Guideline 0-2013, ASHRAE Guideline 1.1-2007, NIBS Guideline 3-2012, and NFPA 4. Other references are available that describe similar processes that may be used at the Using Agency and Design and Construction Agent's discretion.

### 19-3 TOTAL BUILDING COMMISSIONING.

#### 19-3.1 Process Overview.

TBCx must be executed during all project phases, including the design, construction, post-construction, and warranty phases. TBCx must at a minimum include the commissioning requirements of UFC 1-200-02, ASHRAE 189.1, and the requirements of this chapter. TBCx must verify that building systems perform interactively according to the intent of the design, and that the systems meet the Using Agency's operational needs. The Commissioning process must execute and document the commissioning activities required to comply with the Third Party Certification (TPC) requirements for the Project. Provide all commissioning documentation required to meet the TPC requirements.

The minimum systems listed here must be commissioned as appropriate for the specific project:

- a. HVAC systems, including electronic digital control systems and building energy management systems.
- b. Plumbing systems and associated controls.
- c. Medical and dental gas, compressed air, and vacuum systems.
- d. Steam (high, medium, and low pressure), clean steam, and other major energy plant equipment.

- e. EPSs and their interfaces to other critical building system operations.
- f. Automated lighting control systems.
- g. Fire suppression, smoke control, smoke or fire dampers, fire detection and alarm systems, and mass notification systems, and their interfaces to other building system components.
- h. Low-voltage systems including telecommunication infrastructure, NC, ITV, intrusion detection, infant abduction, other ESSs, and other communication systems.
- i. Building systems that are incrementally constructed and commissioned, such as in-phased construction projects.
- j. Energy conservation equipment and systems, including solar hot water system and any renewable energy systems.
- k. Building envelope, including exterior walls, fenestration, roofs, and openings.

### **19-3.2 Commissioning Leadership Structure.**

The Commissioning leadership structure, including roles and responsibilities, must be fully defined in the project requirements documents, as the structure may vary depending on the acquisition strategy, size, complexity of the project, and expertise of the participants. Regardless of leadership structure, the process requires full and open communication for all parties to maximize the benefits of the process. The principle Commissioning Lead definitions and roles are noted here:

#### **19-3.2.1 Commissioning Specialist for the Government (CxG).**

The CxG is an entity having expertise in the commissioning of Military Medical Facilities of a scope and complexity comparable to the individual project, and employed regularly in building commissioning. Refer to 19-3.2.5, Commissioning Lead Qualifications, for additional qualifications.

- a. The CxG may be person(s) employed by the Design and Construction Agent, or an entity directly contracted by the Design and Construction Agent, but not affiliated with the construction contractor. The CxG must provide management and oversight of the Commissioning process through the design, construction, and warranty phases to ensure it is effectively and thoroughly implemented.
- b. The CxG must have documented commissioning authority experience in at least two building projects and be independent of the work of design and construction.

- c. The CxG must meet the requirements and perform the roles specified for the commissioning authority required by the project's TPC. For small DB projects, the commissioning authority role may be provided by an independent third-party commissioning agent hired as a first tier subcontractor to the DB contractor as defined in paragraph 19-3.2.3 and they must meet the requirements and perform the additional roles defined for the CxG in this paragraph. Specific roles include the development and maintenance of the Owner's Project Requirements (OPR), development of the draft Commissioning Plan, and assisting in the development of Systems Manuals for the commissioned systems. At the discretion of the Design and Construction Agent and Using Agency, the CxG must conduct a Lessons-Observed meeting at the end of the Commissioning process to discuss the process used, discuss what worked well and what could be improved, develop recommended improvements for future similar projects, and document the meeting in a closeout report.

#### **19-3.2.2 Commissioning Specialist for the Design Phase (CxD).**

The CxD must be an entity on the Design A/E staff, or directly contracted by the A/E, having expertise in the commissioning of Military Medical Facilities of a scope and complexity comparable to the individual project, and employed regularly in building commissioning. Refer to 19-3.2.5, Commissioning Lead Qualifications, for additional qualifications.

For DBB projects, the CxD must be responsible for development of all design phase commissioning documentation, including hands-on development of the Commissioning Plan, and commissioning specifications to include Pre-Functional Checklists (PFCs) and Functional Performance Tests (FPTs). For DB projects, the CxD must be responsible for developing commissioning scope requirements for inclusion in the RFP.

#### **19-3.2.3 Commissioning Specialist for the Construction Phase (CxC).**

The CxC must be an entity employed as a first tier subcontractor by the construction contractor, independent from the installing contractors, having expertise in the commissioning of Military Medical Facilities of a scope and complexity comparable to the individual project, and employed regularly in building commissioning. Refer to 19-3.2.5, Commissioning Lead Qualifications, for additional qualifications.

19-3.2.3.1 The CxC must be responsible for scheduling and coordinating all construction phase commissioning activities, refinement of PFCs and FPTs to match the specific purchased equipment, and direct oversight and reporting of the execution of the Commissioning process.

19-3.2.3.2 For projects which include design-after-award activities (i.e. Design-Build), the CxC must additionally be responsible for development of all commissioning documents required during design, including the Commissioning Plan and commissioning specifications to include PFCs and FPTs.

**19-3.2.4 Commissioning Lead Application.**

The CxG is required for all project procurement methods. The CxD is typically required for DBB projects, and may be utilized during DB RFP preparation for DB projects. The CxC is typically required for DBB and DB projects.

**19-3.2.5 Commissioning Lead Qualifications.**

The Commissioning Specialist entities must be members of, or certified by, a nationally recognized commissioning organization. Each entity must employ a commissioning professional who must be the Commissioning Lead for their area of responsibility. In addition, each entity must employ additional staff to ensure adequate attention to all systems requiring commissioning as identified in 19-3.

Table 19-1 provides the minimum qualification requirements for Commissioning Lead personnel:

**Table 19-1 Commissioning Lead Personnel Qualifications**

Qualification	CxG	CxD	CxC
Registered Professional Engineer (P.E.)	YES	YES	
Proven hands-on experience in the commissioning of projects of equivalent scope	YES	YES	YES
Certified as a commissioning professional by a nationally recognized commissioning organization	YES	YES	YES

**19-3.3 Commissioning During Design.**

The Commissioning process must be fully defined in the design phase for each project. The CxG should be involved early in project development to facilitate the development of the Using Agency’s OPR document, which records the expectations and requirements for the commissioned systems, and the Commissioning Plan, which outlines the process, commissioned systems, participants, roles and responsibilities, communication procedures, and deliverables. The scope and rigor of Commissioning activities to be completed during construction need to be defined in the contract documents so that they are clearly understood and can be adequately bid. The CxG should review the design documents at various stages of development to verify that the designed systems are commissionable, and suggest alternative designs that would save energy, allow for system optimization, and decrease overall LCC. The CxG must oversee the development of the Commissioning Specifications by the CxD and/or CxC for design after award work features, which define the specific SOW and the roles, responsibilities, and requirements of the construction contractor’s commissioning team members. The specifications must also include draft PFC and FPT procedures for each system to be commissioned to adequately define the scope and rigor required.



#### **19-3.4 Commissioning During Construction.**

During the construction project, it is necessary for the CxG to oversee the contractor's commissioning execution as managed by the CxC to verify that the contractor's proposed testing procedures, personnel, and instrumentation fully meet the design document requirements and that the tests are properly conducted and results documented. As part of the commissioning process, verify that adequate training has been provided on all commissioned systems.

#### **19-4 SPECIFIC SYSTEM REQUIREMENTS.**

##### **19-4.1 Interoperability.**

Various systems, such as HVAC systems, fire protection systems, EPSs, low-voltage systems, and others, may have complex, interwoven operational requirements in some facilities. For each project where applicable, designers must develop new and modify existing specifications as needed to provide for interactive testing of these systems, to permit verification not only of correct function, but of acceptable speed of response, in normal and failure modes of operation and restoration to normal operation. Integrated testing of fire systems and life safety systems must be provided in accordance with NFPA 4. In all cases, detailed testing protocols or system diagrams must be developed to clearly convey the required scope of the commissioning effort.

##### **19-4.2 Addition and Alteration Considerations.**

For addition and alteration projects, commissioning specifications must be developed to describe the step by step procedures required for interim, as well as final, commissioning for systems constructed (or altered) and placed in operation on a temporary, or sequential, basis.

*This Page Intentionally Left Blank*

CANCELLED

## APPENDIX A BEHAVIORAL HEALTH DESIGN

### A-1 GENERAL.

This appendix provides mandatory criteria for the design and development of the built environment for Behavioral Health (BH) functions in new and existing Military Medical Facilities.

### A-2 SCOPE OF BEHAVIORAL HEALTH SERVICES.

#### A-2.1 Inpatient Functions.

Space Planning Criteria Chapter 460 outlines BH services and programs provided in Military Treatment Facilities (MTFs) in the Military Health System (MHS).

Services specifically covered in Chapter 460 are for 24-hour healthcare operations that are provided on inpatient units for Behavioral Health and Substance Abuse / Alcohol Rehabilitation programs. Additionally, Partial Hospitalization Program, which is a day treatment program for patients who need intensive treatment but not 24 hour care, is often collocated with an inpatient BH Unit. The Partial Hospitalization Program will follow the requirements specified for inpatient BH Units in this appendix if the Program is located in an inpatient MTF.

#### A-2.2 Outpatient Functions.

A-2.2.1 Space Planning Criteria Chapter 318 outlines services and programs provided in an outpatient BH setting. Where outpatient is used in this appendix, it includes freestanding BH facilities that include the services noted below, as well as BH clinics located within a hospital or medical center.

Services specifically covered in this chapter are Behavioral Health, Child and Adolescent Services, the Family Advocacy Program, and the Substance Abuse Alcohol Rehabilitation Program (SAARP).

A-2.2.2 Space Planning criteria Chapter 350 (Emergency and Ambulance Services), includes spaces that support the care of BH patients who present to the Emergency Department (ED).

### A-3 BEHAVIORAL HEALTH PROGRAM.

#### A-3.1 Concept.

The Using Agency must determine the BH service(s) in accordance with specific project requirements. Once specific BH services are identified, a Concept of Operations (CONOPS) must be developed by the Using Agency which must outline how the inpatient BH Unit, or outpatient clinic, will function within the physical environment. The CONOPS must be carefully planned with the Using Agency's Surgeon General's BH Consultant and facility end users to identify how the design criteria, as outlined in this

appendix, will be implemented and identified when developing the scope of work for the project.

### **A-3.2 Design Guide for the Built Environment of Behavioral Health Facilities.**

Design of the inpatient BH Unit, and where appropriate for the outpatient BH setting, must meet all of the requirements of the current Design Guide for the Built Environment of Behavioral Health Facilities and the associated Safety Risk Assessment (SRA), which is published by The Facility Guidelines Institute. In addition to the CONOPS, the SRA will be used to identify project specific design requirements. The SRA must be initiated by DHA/FE for MILCON projects. The A/E of Record must be responsible for maintaining and updating the SRA during design and construction. Refer to Chapter 3 Design for specific SRA requirements and Appendix C for design submittal requirements.

## **A-4 CONSULTING SERVICES**

For inpatient BH projects, the A/E of Record must provide the services of a qualified behavioral health consultant at project initiation, who must provide design, Fixtures, Furnishings & Equipment (FF&E) and Low Voltage Systems input to inform the 35 percent design effort. The consultant must also provide input on the project SRA throughout the design process to identify potential safety concerns, foster dialogue, consider and present possible solutions, and explain the positive and negative elements of each, in collaboration with DHA/FE and the Using Agency. A qualified behavioral health consultant is one who has been in business or employed as a behavioral health professional or provider, for a period of not less than five years, and has had experience with the planning and design of inpatient and outpatient behavioral health medical facilities. The consultant must not be involved in the sale, installation, distribution, manufacture, or representation of behavioral health equipment. Furthermore, the consultant must demonstrate prior experience with DoD or Federal Military Medical Facilities that relates to the scope and nature of the project to include locations OCONUS, if applicable.

## **A-5 DESIGN CRITERIA.**

### **A-5.1 Environment.**

Particularly in Behavioral Health care, it is essential to design a safe, functional, therapeutic, and aesthetically pleasing, non-institutional environment that “normalizes life” for patients, staff, and visitors. There are three “areas of concern” that must be considered when designing a BH environment: 1) Patient Safety – reducing risks for suicide/self-harm or harm to other patients; 2) Staff Safety – reducing risks or opportunities for patients to harm attending staff; and 3) Structural Resistance – reducing damage to facilities and preventing an increase in maintenance costs. Adherence to applicable codes and regulations, the completion of the CONOPS and the SRA, as well as the implementation of the following design criteria will contribute to the desired outcome. Project definition and management control documents should state

unequivocally that, whereas safety of staff and patients is paramount, the design intent is to limit the “institutional” look of the inpatient BH Unit or outpatient clinic. Contractual requirements must specifically direct early notification to the Design and Construction Agent, DHA/FE and the Using Agency of any conflict between “non-institutional” design, materials and fixtures that are being considered for selection and the safety of staff and patients.

#### **A-5.1.1 Exterior Spaces.**

An outdoor area should be considered during project design to support respite and group activities as a component of the inpatient BH therapeutic environment. This outdoor area, which may have attached or unattached canopies or overhangs, will comply with Chapter 3 Design for scope and cost estimating. Careful consideration of the location and design of this outdoor space to reduce the risk of elopement, climbing, jumping, impalement and concealment in relation to furniture selection and placement, sufficient lighting for night time use and landscaping features are essential. Other applicable design considerations and safety features are noted in the sections below.

#### **A-5.1.2 Interior Spaces.**

Drivers that influence the selection of materials include durability and maintenance, infection control, integrated way finding and sustainability. Every effort must be made to eliminate ligature points, sharp edges, and the potential to make weapons out of objects or materials. The term ligature resistant as used in this Appendix is defined as “without points where a cord, rope, bed sheet, or other fabric/material can be looped or tied to create a sustainable point of attachment that may result in self-harm or loss of life.” This is consistent with The Joint Commission’s definition,

The Using Agency must validate the SEPS generated Project Room Contents (PRC) during CONOPS and RFP development to ensure JSNs reflect the current Design Guide and/or Using Agency project-specific requirements.

#### **A-5.1.3 Architecture**

When developing the design and layout of spaces for BH care for inpatient and outpatient settings:

- a. Avoid dead-end corridors, alcoves or other architectural features that provide concealment or blind spots.
- b. Provide column-free spaces in patient bedrooms, group therapy or counseling rooms, activity rooms and other rooms where patients and staff interact.
- c. Provide staff areas that promote team collaboration and HIPAA compliance while maintaining visibility and connection between the care team and patients. Design staff areas to provide an area of refuge (not used in the context of Life Safety Codes) for staff safety.

- d. Maximize windows to exterior and interior spaces to create a sense of transparency, openness and safety.
- e. Segregate noisy activities (art therapy) and quiet activities (patient bedrooms or counseling spaces) to improve processes and consolidate disciplines.
- f. Locate staff support spaces such as janitor closets and soiled utility rooms, in an area that promotes access without having to enter secure patient areas.
- g. Through careful coordination, orientation and layout of furniture and equipment, provide a clear path of egress or an “escape corridor” in BH provider/counselor offices, group therapy rooms and other locations where staff and patients interact.
- h. Do not reduce the size of BH counseling rooms (OFDC1, OFDC2) as noted in Space Planning Criteria Chapters 460 and 318.

#### **A-5.1.4 Furniture, Fixtures and Artwork.**

For the inpatient BH Unit, the use of rounded edges and curves as well as providing furniture, fixtures, and artwork that meet or exceed the requirements noted in the current Design Guide must maximize safety for patients, staff and visitors. The furniture in BH patient bedrooms must be minimized, heavily weighted or fixed to the floor, be non-breakable and contain no compartments for hiding. Provide ligature resistant clothes hooks. The location of inpatient BH Unit furniture must be coordinated with the ceiling plan to avoid patients gaining access to ceiling fixtures. Artwork selected for inpatient and outpatient BH settings must be soothing and provide a connection to nature. The Using Agency must define specific inpatient BH Unit requirements for location of artwork as well as instructions for mounting and hanging of artwork to avoid ligature risks or detachment from the wall. Wall mural artwork must be considered in BH patient bedrooms, or elsewhere on the BH Unit, to facilitate minimizing the safety risks. Cabinet locks are required in all patient accessible areas of the inpatient BH Unit and must be considered in the outpatient setting for areas where patients may be unsupervised for even short durations.

#### **A-5.1.5 Finishes.**

Select colors, textures and surfaces that are soothing and provide a connection to nature for both the inpatient and outpatient BH settings. Ensure finishes do not produce a harsh glare, shiny surface or distorted reflections. Wall and other room finish materials must be securely constructed to resist attempts at intentional damage or removal. Inpatient BH Unit wall and ceiling finishes must be abrasion and indentation resistant; wood veneer products with a natural finish and must meet the latest ANSI/HPVA HP-1 tolerance standards. For other specific finishes, the products must meet or exceed the minimum requirements as noted in the current Design Guide.

#### **A-5.1.6 Walls.**

For inpatient BH Units, the wall assembly must be abrasion resistant and impact resistant gypsum board. Heavier construction materials, as recommended by the current Design Guide safety guidelines, should be provided for the inpatient BH Unit seclusion rooms and Emergency Department secure holding rooms. Wall cove base used for inpatient BH Units should be cut into short lengths not to exceed 14 inches.

#### **A-5.1.7 Ceilings.**

Follow the Appendix B Architectural and Engineering Design Requirements ceiling type and height requirements for all room codes noted in the project specific Program for Design (PFD). When specified by the inpatient BH Unit CONOPS and SRA, where hard ceilings are required they must be impact resistant gypsum board. Provide key lockable access panels that comply with the Design Guide in gypsum board ceilings. Where lay-in ceilings are permitted, the use of security clips must be provided to restrict access to ligature risk points in the space above the drop ceiling. The installation of motion sensors above lay-in ceilings to alert staff to patient tampering is not a mandatory safety measure and they should only be used where required by the project SRA. The location of ceiling fixtures such as overhead lights, sprinklers, and registers on an inpatient BH Unit must be coordinated with room furniture plans and the current Design Guide safety guidelines. Where inpatient BH Unit patients may be unsupervised or interact with staff on a one-on-one basis, it is important to ensure furniture cannot be moved, stacked or climbed upon to access any ceiling fixtures or materials.

#### **A-5.1.8 Floors.**

The Appendix B Architectural and Engineering Design Requirements data for all BH room codes are appropriate for flooring material in both inpatient and outpatient settings. To enhance safety, minimize joints and seams to the furthest extent possible in all BH room codes outfitted with tile or sheeting.

#### **A-5.1.9 Doors.**

Door access control devices must be provided in accordance with Chapter 5 Antiterrorism (AT) and Life Safety. A sally port must be provided at the primary entry to the inpatient BH Unit, and it must lock and unlock in sequence to optimize access control. If a sally port is provided at the secondary entry, it must also meet the requirements for sequential locking. Where patient bedroom doors require locking, the use of a ligature resistant “classroom” type lock must be provided. Reevaluation of inpatient BH Unit door types and hardware must be assessed in conjunction with the CONOPS, SRA and the development of contract documents to minimize safety risks. All inpatient BH Unit doors and hardware which includes but may not be limited to, hinges and handles, must comply with the requirements as outlined in the current edition of the Design Guide. The project SRA must identify which doors on the inpatient BH Unit are required to have risk-mitigation devices installed to decrease the chance that the top of a corridor door will be used as a ligature attachment point. The CONOPS

must identify additional risk mitigation strategies, such as appropriate rounding and monitoring by staff, or requiring that doors be left open during certain hours.

In inpatient and outpatient settings, when solid doors are installed, they will be outward swinging or utilize rescue hardware that provides double acting, continuous pivot hinges.

#### **A-5.1.10 Windows and Glazing.**

Impact-resistant glass products must be used in all patient accessible areas inclusive of interior window surfaces, and on the interior face of exterior windows in all inpatient BH Units.

- a. Designed to resist impact loads of 2,000 foot-pounds applied from the inside.
- b. Tested in accordance with AAMA 501.8-13: Standard Test Method for Determination of Resistance to Human Impact of Window Systems Intended for Use in Psychiatric Applications. Where operable windows are used, hinges and locking devices must also be tested.

Impact-resistant glass products must also be provided on the interior surface of exterior windows where the window sill is 6 feet-6 inches or less in areas accessed by inpatients. Impact-resistant glass products are also recommended for outpatient facilities in areas where patients may be left unattended. Glazing manufacturer should decide the thickness based on calculations. Laminated glazing is the preferred alternative to glass-clad polycarbonate glazing.

All exterior windows in BH patient bedrooms must have integral blinds. For other inpatient and outpatient settings, window treatments must be roller shades specifically manufactured for use in the BH setting that meet or exceed the current minimum Design Guide requirements.

#### **A-5.1.11 Mechanical HVAC.**

HVAC Air Diffusion Devices (i.e. grilles, registers, etc): Provide vandal and ligature resistant air diffusion devices in accordance with the current minimum Design Guide requirements. Where perforated diffusion devices are required, perforations must be a maximum of 3/16 inch.

A-5.1.11.1 Thermostats: Provide thermostats in accordance with the current minimum Design Guide requirements.

A-5.1.11.2 CO2 sensors: CO2 sensors may not currently be available in a ligature resistant style and should only be used where permitted by the project SRA. CO2 sensors may be installed within ducts.



**A-5.1.12 Plumbing.**

Inpatient plumbing fixtures must be ligature resistant and must include floor mounted toilets constructed of high impact resistant materials that promote a residential versus institutional setting. Shut-off valves and cleanouts for fixtures in BH patient bedrooms must be directly accessible from the corridor. Install tamper / vandal resistant drains in all inpatient bathrooms, toilet/showers, kitchenettes and laundry rooms. Provide a floor drain for each shower and a second floor drain for the bathroom area. Select drain types that are ligature resistant and that minimize opportunities for intentional blockage. If inpatients are to be unsupervised during showering, install a “timing” system that has a re-set capability to limit the length of time that shower water may continuously flow.

**A-5.1.13 Electrical.**

Electrical power outlets provided in all areas of the inpatient BH Unit must be tamper / vandal resistant and GFCI. Inpatient electrical switches and outlets must be made of polycarbonate material and be affixed with tamper / vandal resistant screws to reduce the risk of exposing the wiring. The project specific CONOPS and SRA must identify whether outlets are to be provided in the BH Unit patient bedrooms or toilet/showers. When outlets are provided in these inpatient rooms, they must have a dedicated circuit. No outlets will be provided in the BH Unit seclusion rooms or the ED secure holding rooms. In the outpatient setting, outlets must be tamper resistant only.

**A-5.1.14 Lighting.**

The Using Agency must address the placement of table lamps for the outpatient setting in the CONOPS and SRA. Table lamps must not be provided in the secure area of inpatient BH Units. Inpatient BH Unit light fixtures must be tamper / vandal resistant and ligature resistant. Lenses must be impact resistant. BH light fixtures must be provided in all inpatient BH areas, including corridors; counseling, interview, activity, and patient bedrooms. BH light fixtures must also be provided in inpatient areas not under direct observation by staff, including blind spots and areas not under video surveillance. In the BH patient bedroom, provide a tamper/vandal proof, ligature resistant night light that is situated close to floor level to light the path of travel from the patient bed into the patient bathroom. The night light must be activated by light level and by a switch exterior to the patient bedroom. For inpatient BH Units, interior lights must be installed in painted hollow metal frames with laminated glazing. The glazing thickness and the size of the glazing stop should be based on the size of the light. Tamper /vandal resistant screws must be utilized to secure the glazing stops. The inpatient and outpatient CONOPS must note any requirement for dimming capability in rooms that are not already required per Appendix B Architectural and Engineering Design Requirements to have this feature. BH device plates (switches, receptacles, covers) must be impact and vandal resistant. BH device plates must be provided in all areas where BH light fixtures are required, to include outpatient settings per the CONOPS and SRA. Tamper resistant fasteners must be provided for BH light fixtures and device plates.

**A-5.1.15            Communication.**

**A-5.1.15.1        Audio/Visual.**

At the primary entry to a BH Unit, an audio/visual communications system will be provided connecting this entrance to the staff /nurse station, or as otherwise directed by Using Agency in the CONOPS, to provide call-to-enter capability.

**A-5.1.15.2        Nurse Call.**

Nurse call push buttons must be provided for BH patient bedrooms and the associated toilet/shower, and for patient toilets in inpatient and outpatient settings. Pull cords are prohibited. On the inpatient BH Unit, staff call-back must be via ceiling mounted speakers and microphones. A dome light over the inpatient toilet/shower door is not required. A nurse call override switch must be provided outside each BH Unit bedroom and seclusion room and ED secure holding room.

**A-5.1.15.3        Behavioral Health Staff Assist Alarm.**

A BH Staff Assist Alarm system must be provided for inpatient and outpatient BH settings; refer also to CHAPTER 12 Communications. The BH Staff Assist Alarm system is a component of the Electronic Security system and is categorized as Personal Property according to Section 6 of MIL-STD-1691. The BH Staff Assist Alarm system must be independent of the Nurse Call system. Additionally, the BH Staff Assist Alarm system must NOT be connected to the facility local area network (hardwired or wireless). The system must integrate wireless staff assist devices carried by staff AND the hardwired staff assist alarm buttons located in provider offices, conference rooms, group rooms and other spaces where staff/patient interface occurs as specified by the Using Agency CONOPs and SRA. The BH Staff Assist Alarm must transmit a signal to an annunciator station monitor located at the reception point or other location identified by the Using Agency CONOPs. At the annunciator station monitor an alarm tone must sound and a graphical display must indicate the signal origination point, the identity and location of the staff member sending the alarm. The components of the BH Staff Assist Alarm system provide an opportunity for BH staff to be "first" responders and intervene in situations that do not require assistance from the Facility Security office or the Installation Provost Marshall. If a situation escalates and an emergency arises, then the Duress Alarm system must be activated.

**A-5.1.15.4        Duress Alarm System.**

In the event a situation requires an elevated level of response from either the Facility Security office or Installation security, staff must immediately activate a Duress Alarm button or equivalent. The Duress Alarm system must communicate with other entities on the Installation as determined by the CONOPs and the SRA. At each annunciator station provide wiring, conduit, power supply, buttons and other appurtenances to support the Duress Alarm system. Duress Alarm buttons must be located in areas where staff are present at all times; for inpatient BH Units, this must be at the staff / nurse station, and for outpatient BH settings it must be at the reception desk.

#### **A-5.1.16 Video Surveillance System.**

For inpatient BH units, Video Surveillance System (VSS) cameras must be located as determined with the Using Agency. VSS cameras must not record audio; they must be used for video monitoring only. Monitoring stations must be provided on the inpatient BH Unit and at a central security location in the MTF, as directed by the Using Agency. As a minimum, cameras must be located to assist with supervision of the admissions / triage area, group activity areas, corridors, entrances, fire exits, staff / nurse station(s), exercise areas (interior and exterior), and patient laundry. VSS cameras must not be provided in BH patient bedrooms; they may be provided in seclusion rooms on the BH Unit or secure holding in the ED. Cameras must be tamper /vandal resistant; they may be unique for the BH Unit or ED BH spaces rather than integrated with the MTF security system. Video surveillance system cameras, where ceiling mounted must be ligature resistant and mounted with tamper resistant fasteners. Camera cases and lenses must be impact resistant or shatter proof. The use and location of VSS cameras in the outpatient setting must be addressed in the Using Agency CONOPS and SRA, and must meet the above technical and monitoring requirements.

#### **A-5.1.17 Televisions.**

Televisions must not be provided in BH patient bedrooms. The CONOPS must define the location of TVs in other spaces for inpatient and outpatient settings and this information must be reflected in the project's PRC. TVs must be wall mounted and meet or exceed the current minimum safety requirements noted in the Design Guide.

#### **A-5.1.18 Security.**

In accordance with the Using Agency CONOPs and SRA, provide a small safe in a secured location close to, but outside, the primary entrance of the inpatient BH Unit to permit security personnel to stow side arms prior to entering the Unit. Remote release of BH Unit entry doors is prohibited. Provide for security of the BH Unit during quiet hours in accordance with the Using Agency CONOPS and SRA. Inpatient BH Unit requirements development must consider as a minimum: control of corridor lighting including motion detectors, securing of patient bedroom doors; notification of patient bedroom door switch position to staff / nurse station; incorporation of a security sally port at the primary and secondary BH Unit entrances; VSS monitoring activated by motion detectors; and Electronic Security System access control at entrances/exits (interior and exterior), staff-only spaces, fire stairwells, etc. For outpatient settings provide Electronic Security System electronic access control in accordance with the Using Agency CONOPs and SRA, but as a minimum to control access from reception/waiting to treatment areas and from the treatment areas to any back-of-house corridors. Consider providing VSS associated with the duress button normally located at reception and in accordance with the Using Agency CONOPs and SRA.

#### **A-5.1.19 Life Safety.**

Life safety is a paramount consideration that poses special challenges for inpatient BH Units because of the conflicting requirement of maintaining security of exits. Inpatient

BH Unit exit doors, including associated stairwell doors, will usually be secured by electromagnetic locks as a component of the Electronic Security System. These electromagnetic locks automatically release during fire alarm activation but may be programmed with a time delay before egress is allowed. The project specific CONOPS and SRA must address whether these doors are designed to "fail safe" or "fail secure" on fire alarm activation and release of the electromagnetic lock. The Life Safety Code, NFPA 101, allows some latitude with the local AHJ's approval and must be coordinated during the Using Agency development of the CONOPS and subsequent design development. Issues to be considered include, but are not limited to: provision of a door security override switch at the inpatient BH Unit staff / nurse station, staff carrying keys to manually release egress route doors, limiting alarm notification to avoid panicking patients.

**A-6                    EQUIPMENT SPECIFICATIONS.**

All equipment must meet or exceed the minimum requirements and standards as noted in the current Design Guide. Vendors will often use the terms "tamper-proof", "tamper-resistant", "vandal proof", "institutional", etc. arbitrarily. Specifications and submittals for equipment provided both by the construction contractor and for initial outfitting purchases should be very closely examined to ensure they meet the intent of the Design Guide and the SRA.

## APPENDIX B ARCHITECTURAL AND ENGINEERING DESIGN REQUIREMENTS

### B-1 SYNOPSIS.

Appendix B is a compilation of mandatory architectural and engineering design criteria organized by standard Room Codes. The Design and Construction Agent, in conjunction with the Using Agency, may provide additional criteria to meet special needs, e.g., bariatric design, demountable partitions, contingency facilities. The Room Codes used to organize Appendix B are the same as the codes used to organize the PFD and the Equipment List so that the initial design requirements should be well established for the A/E. For Room Codes that are used, but are not included in Table B-1, the room criteria must be obtained from the Using Agency. A period (".") indicates that there is no specific requirement for this parameter or the parameter matches the ambient conditions.

### B-2 LEGEND & NOTES.

#### B-2.1 Room Code.

Room identifier from *DoD Space Planning Criteria for Health Facilities*. This five digit Code is the reference key that ties the Appendix B criteria to the project PFD.

- \* An asterisk (\*) prior to the Room Code indicates that it is a new Room Code added since the previous UFC version.
- The letter "X" in the fifth digit indicates that the Appendix B criteria applies to multiple spaces/room codes in accordance with PFD.

#### B-2.2 Room Function.

Room function from *DoD Space Planning Criteria for Health Facilities*.

##### B-2.2.1 Code.

Category of Patient Care Space in accordance with NFPA 99. The listed code defines the category for the expected Patient Care Space function. The Using Agency must define room function and reassess codes to be used for the specific project. The A/E must validate the room function and propose appropriate changes to a room category for Patient Care Spaces: the A/E will ensure the architectural and engineering criteria are appropriate for the code used. A waiver will be required for changes to room categories.

The categories of Patient Care Spaces are independent from and should not be confused with Building System Categories. Building System Categories must be as defined in NFPA 99.

- 1 Category 1 – Critical Care Space
- 2 Category 2 – General Care Space

- 3 Category 3 – Basic Care Space
- 4 Category 4 – Support Space
- C Category to be determined by the Using Agency
- N Not applicable. This room is not intended for patient examination or treatment.

### **B-2.3 Space Parameter Notes.**

For room codes that do not have Architectural and Engineering design parameters listed, utilize the following notes:

- a. For this room code, utilize the Architectural and Engineering parameters of the room where this area is located unless otherwise directed by the Using Agency.
- b. This new room code is under development. Architectural and Engineering parameters must be provided by the Design and Construction Agent and Using Agency.
- c. Provide emergency power for selected electrical receptacles.
- d. Provide essential power only as required by the Using Agency for selected equipment connections.
- e. Provide dedicated exhaust for this area.

### **B-3 ARCHITECTURAL.**

#### **B-3.1 Materials and Finishes.**

- B-3.1.1 FL Floor and base finishes. See Architectural Note 1.
- AR Acrylic resin system with integral coved base. See Architectural Note 9.
- CP Carpet Tile with resilient base. See Architectural Note 2 and 12.
- CS Concrete sealer. Resilient base on gypsum wallboard and plaster walls. No base on concrete or block walls.
- CT Ceramic or Porcelain tile with ceramic/porcelain tile base.
- ER Poured epoxy resin system with integral coved base. Includes epoxy terrazzo flooring systems. See Architectural Note 9.
- LV Luxury vinyl tile with resilient base. See Architectural Note 2.
- PF Prefabricated.
- PS Poured specialty flooring
- RT Rubber tile with rubber base.

- SD Static Dissipative Tile
- SF Safety Flooring
- SP Special. Determined by the Design and Construction Agent in coordination with the Using Agency.
- SR Sheet rubber with integral rubber base.
- SV Sheet vinyl with integral vinyl base. See Architectural Note 3.
- US Using Agency specific sheet goods:  
For Navy facilities, use SV. Otherwise, use SR.
- UT Using Agency specific tile:  
For Navy facilities, use VT. Otherwise, use RT.
- VT Vinyl composition tile with resilient base. See Architectural Note 2.

B-3.1.2 WL Wall Material & Finish. First character is wall material. Second and third characters are finish. See Architectural Note 1.

Wall Material (first character)

- C Concrete.
- B Concrete block or clay tile.
- G Gypsum wallboard. See Architectural Note 4.
- L Lead lined gypsum wallboard. See Architectural Note 11.
- S Special. Determined by the Design and Construction Agent in coordination with the Using Agency.

Wall finish material (second and third characters)

- AF Acoustical wall fabric.
- CS Concrete sealer.
- CT Ceramic or Porcelain tile.
- LG Liquid Glaze Coat. See Architectural Note 5.
- PF Prefabricated.
- PT Paint.
- EL Epoxy coating, seamless, lead lined.
- EP Epoxy coating, seamless.
- SP Special. Determined by the Design and Construction Agent in coordination with the Using Agency.

B-3.1.3 CLG Ceiling Material and Finish. See Architectural Note 1. First character is ceiling material. Second and third characters are finish.

Ceiling material (first character)

- A Acoustic ceiling tile.
- C Concrete.
- E No ceiling required, exposed to floor/roof above.
- G Gypsum wallboard.
- S Special. Determined by the Design and Construction Agent in coordination with the Using Agency.

Ceiling Finish Material (Second and third characters)

- CS Concrete sealer.
- LG Liquid Glaze Coat.
- PF Prefabricated.
- PT Paint.
- SP Special. Determined by the Design and Construction Agent in coordination with the Using Agency.
- EP Epoxy coating, seamless, with coved corners.
- T1 Standard finish.
- T2 Waterproof finish.
- XP No ceiling or finish required, exposed to floor/roof above.

**B-3.2 CLG HT.**

Ceiling height in feet and inches, unless noted otherwise.

- A 10'-0" minimum.
- B If ceiling is provided, 10'-0" minimum.
- C No ceiling required, exposed to floor/roof above.
- D 9'-0" minimum or as required to accommodate equipment usage.
- VAR Varies (Designer's choice).

**B-3.3 DOOR SIZE.**

Door width in feet and inches, unless noted otherwise.

- A Pair 2'-6" doors
- B Pair 3'-0" doors
- C { not used }
- D Double doors, uneven: 4'-0" and 1'-6"



- E Pair 3'-0" doors or 4'-0" doors as directed by the Using Agency.
- F { not used }
- G In clinics, provide 3'-6"  
In hospitals, provide uneven double doors, 3'-6" and 1'-6"
- H Pair 4'-0" doors, 8'-6" breakaway glass doors, or uneven double doors (4'-0" and 1'-6") as directed by the Using Agency.
- I 10'-0" by 10'-0" minimum. Number as required by dock.
- J Main OR door, pair 3'-0" doors. Staff door from clean corridor, 4'-0". Door to sub-sterile, 3'-6".
- K Main OR door, pair 3'-0" doors or 4'-0" and 1'-6" or 3'-6" and 1'-6" as directed by the Using Agency. Staff door from clean corridor, 4'-0". Door to sub-sterile, 3'-6".
- L Open (no door).
- M Open (no door) or 3'-0" door as directed by the Using Agency.
- N Open (no door) or 4'-0" door as directed by the Using Agency.
- O { not used }
- P Open (no door). Provide cubicle curtain only at entrance to cubicle and minimum 4'-0" door into area where the cubicles are located.
- SP Special. Determined by the Design and Construction Agent in coordination with the Using Agency
- VAR Varies (Designer's choice).
- VET Special door in veterinary facility. See Architectural Note 10.

#### **B-3.4 NOISE.**

The first line indicates the allowable range (minimum to maximum) noise coefficient (NC) required in the room. See Architectural Note 7.

The second line indicates the Sound Transmission Class (STC) required. See Architectural Note 8.

- SP Special requirements. Determined by the Design and Construction Agent in coordination with the Using Agency.
- STC 50\* An asterisk after the 50 designates that the STC requirement is 50 for all facilities except Naval facilities, in which case the STC requirement is 40.

**B-4 ARCHITECTURAL NOTES.**

1. When two finishes are appropriate for a room, provide the preferred finish (1st line) shown in Appendix B, unless the Design and Construction Agent selects the alternate finish (2nd line) after coordinating with the Using Agency and DHA/FE. Provide the finishes shown in Appendix B used unless otherwise approved by the Using Agency, coordinated with DHA/FE and directed by the Design and Construction Agent.
2. Resilient Base. Rubber or vinyl coved base for use with resilient tile and carpet. Coved base must terminate and butt at the face return of steel door jambs. Fire-retardant wood blocking or metal runners must be provided at the steel stud base channel runner for all gypsum board corridor walls.
3. Sheet Vinyl. Solid, seamless vinyl in roll format with routed, welded, grooved seams where melted vinyl is used for an impervious, waterproof seal. Chemical sealants are unacceptable. Cushioned sheet vinyl may not be used. Provide seamless sheet vinyl base integral with the flooring, using the same joint sealing application technique of grooved, melted, welded, vinyl, for an impervious waterproof seal.
4. Gypsum wallboard. Minimum 5/8 inch. Ensure that the proper gypsum wallboard product used is appropriate for the application (wet areas, fire resistance, damp conditions, radiation protection, etc.). Utilize lead lined gypsum board where lead lined walls are determined to be required, reference Architectural Note 11.
5. Liquid Glaze Coat (LGC). This coating is a seamless, sprayed-on, lusterless, semi-gloss, two-component, polyester epoxy or polyurethane finish. As an alternative, water-based epoxy with semi-gloss finish may be used. In humid climates, avoid the use of LGC on interior surface of exterior wall.
6. Sheet Rubber. Solid, seamless rubber in roll format with routed, welded, grooved seams where melted rubber is used for an impervious, waterproof seal. Provide seamless sheet rubber base integral with the flooring, using the same joint sealing application technique of grooved, melted, welded, rubber for an impervious waterproof seal. Sheet rubber flooring requires heat and chemical welds for a proper installation (chemical welds for vertical seams and sanitary wall base applications).
7. The acoustical noise level range in the room is the design value for the NC-level for the background (ambient) noise level.

- 8 The STC specifies the performance of the room enclosure in isolating against airborne sound. The wall partition/ceiling system, including penetrations, must be designed to this value. This design value is generally considered as a minimum rating. For corridor walls that contain a door, window, or other penetration, a composite STC 35 may be used, unless the room has special acoustical privacy concerns as determined by the Using Agency. The composite STC rating must be the calculated value that considers the STC rating and the area percentages of the individual wall, door, and other components. Maintain the specified STC for common walls with public spaces, service areas, and rooms with higher STC requirements.
- 9 Provide non-slip finishes in corridors and all areas where pedestrian traffic is anticipated. Provide smooth finish where greater degree of cleanability is required (under cage racks, for example).
- 10 Provide vermin-proof hollow metal doors, 48 inch by 96 inch, with 12 inch by 12 inch red glass vision panel and recessed hardware. Provide door seals. Do not provide door lock.
- 11 A health physicist must determine the required degree of protection to minimize exposure to primary and secondary radiation, as required to achieve compliance with NCRP Report No. 147. Shielding must be designed by the health physicist. Due to the intended use, rooms BMCW2, XDR01 and XDRF1 require a minimum of 1/16-inch thick lead shielding, or more if so determined by the health physicist. Rooms requiring shielding must be certified in accordance with NCRP Report No. 102 and the Using Agency qualified expert.
- 12 Carpet Tile must meet TARR (Texture Appearance Retention Rating) classification ratings based on location areas where it is being used. Reference the Carpet and Rug Institute (CRI) Fact Sheet for more information.

Space Definition	Traffic Classification	TARR Classification
Chapel, Staff sleeping & watch areas	Moderate	≥ 2.5 TARR
Training Rooms, Conference, Private Offices, Classrooms, Consultation Rooms, Libraries, Lounges	Heavy	≥ 3.0 TARR
Open Office, Cafeteria, Corridors, Lobbies, Clinical Waiting Areas (outpatient/pharmacy/ancillary zones), Entrance Areas, Playrooms-OB/GYN-Peds Clinics,	Severe	≥ 3.5 TARR

**B-5 STRUCTURAL.**

Minimum uniformly distributed live load in pounds per square foot (psf), unless noted otherwise.

- A Design for minimum of actual wheel loads or 150 psf.
- B Design for minimum actual equipment loads or 150 psf.
- C Design for minimum actual equipment loads or 100 psf.
- D Design for minimum actual weight of shelves plus 3.1 pounds/filling inch or 150 psf.
- E Floor loading is being reviewed. Obtain required floor loading from the Design and Construction Agent.
- F Reference UFC 3-301-01 for floor loading requirements.

**B-6 ELECTRICAL.**

**B-6.1 LIGHT.**

B-6.1.1 LEV Maintained lighting level in lux with permanently installed building fixtures. Where multi-level lighting levels are indicated, provide multi-level switching for fluorescent fixtures and full range dimming for LED fixtures with conventional on/off switching unless otherwise noted. The first line is the general lighting level and the second line is the task illumination level provided by permanently installed building light fixtures. These lighting levels are in addition to supplemental lighting provided with furniture or equipment. However, the Using Agency may direct that the task lighting be provided with the office furniture in administrative areas, except for dual purpose clinical/administrative rooms, rather than permanently installed light fixtures.

- B-6.1.2
- N Lighting Notes.
  - A Provide full-range dimming in room.
  - B Provide recessed ceiling exam fixture that provides required task illumination on bed or patient area controlled at the headwall.
  - C { not used }
  - D Provide O.R. type light fixture. Those fixtures that have battery backup must have full illumination when energized by battery or uninterruptable power supply (UPS). If fluorescent lights are used the minimum CRI must be 90.
  - E Explosion Proof design typically required.
  - F Provide lighting control at individual task location in lieu of multi-level switching.
  - G Provide Safelight for film processing as required by Equipment List.

- H Provide full-range dimming at task location.
- I Provide recessed ceiling mounted task illumination with full-range dimming.
- J Ceiling mounted lights must be switch controlled to achieve 50 percent and 100 percent illumination levels.
- K Provide Violet Fraction of the light source between 4% and 6%.

## **B-6.2 ES PWR.**

Essential power required in room. Provide additional essential power as required by NFPA 99.

B-6.2.1 PW Approximate percentage of general power outlets on essential system or note as listed below.

- R Selected receptacles (not less than 50 percent of the receptacles).
- R1 One receptacle per bed.
- RA All receptacles.
- RC Dedicated receptacles for critical care (reference NFPA 70, Article 517).

B-6.2.2 LT Approximate percentage of lighting on essential system or note as listed below.

- L Task Lighting.
- LB Task Lighting, General Illumination, and battery powered lighting. Reference Chapter 11 Electrical.
- LG General Illumination.
- LS Task Lighting and Selected General Illumination identified and coordinated with the Using Agency.

B-6.2.3 N Essential Power notes.

- E Selected equipment connections.
- U Provide essential power only as required by the Using Agency.
- S Special (Non-standard areas).

## **B-7 MEDICAL GASES.**

The number of outlets/inlets required for each gas type is listed in the appropriate column. The number of outlets/inlets must be increased as required to support the equipment listed in the PRC.

MA	Medical Compressed Air
DA	Dental Compressed Air
LA	Laboratory Compressed Air
PA	Process Compressed Air
MV	Medical Vacuum
DSV	Dental Surgical Vacuum
OE	Oral Evacuation
LDE	Laboratory Dust Evacuation
O	Oxygen
NO	Nitrous Oxide
CO2	Carbon Dioxide
IA	Instrument Compressed Air
WAGD	Waste Anesthetic Gas Disposal
N	See Medical Gas Notes.

#### B-7.1

#### MEDICAL GAS NOTES.

- A. Each patient is provided with the number of outlet(s) listed.  
  
Each patient is provided medical vacuum inlet(s). See individual listing.  
  
Each patient is provided access to a medical air outlet. Where two patients share a common wall, they may share a single outlet, excluding behavioral health patients. Do not provide in pediatric play area.
- B. The medical gases specified must be per patient station, workstation, etc.
- C. Coordinate with the Using Agency for location of outlets/inlets.
- D. All anesthetizing locations must have a WAGD system. Use of medical vacuum system is not recommended for evacuation in DoD facilities. DSV may be used in DTRs for anesthesia scavenging where a central system is installed.
- E. One each O, MA, and MV is required at the headwall unit and the infant resuscitation area of the birthing room.
- F. { not used }

- G. The medical gases specified must be per bassinets or infant station.
- H. The medical gases specified must be per 4 bassinets or infant stations. Where the LDR birthing room concept is used, a minimum of one grouping must be provided in each LDR.
- I. For equipment testing and calibration, equipment must be tested with the specific gas used in normal operation.
- J. Provide valve regulator station for PA.
- K. Each DTR chair and 12 o'clock column as called out in the PRC, i.e. utility center, requires 1 DA and 1 OE. If the PCRC does not include 12 o'clock column(s) in a specific room, provide 1 DA and 1 OE for each DTR chair.
- L. A natural gas outlet (mounted under counter) and a LA outlet (mounted under counter) must be provided at each dental work station as shown in Appendix B.
- M. All contingency beds require 1 O, 1 MV, and 1 MA per bed station. In bed expansion situations in "peace time" facilities also provide 1 O, 1 MV, and 1 MA per contingency bed expansion requirements noted in the PFD.

**B-8 HVAC.**

**B-8.1 BL. Air Balance**

- ++ Room exhaust, return, or both, is 20 percent less than supply
- + Room exhaust, return, or both, is 10 percent less than supply
- 0 Room exhaust, return, or both, is equal to supply
- Room exhaust, return, or both, is 10 percent more than supply
- Room exhaust, return, or both, is 20 percent more than supply
- EX Room exhausted. If supply is provided, exhaust room Air Change must be in addition to the amount of supply provided.
- r Letter "r" indicates the HVAC Notes provide the required air balance

Note: for "++" and "--" spaces, the required differential pressurization is 0.02 inch water column, reference 10-7.5. Adjust air flows and/or increase room integrity as required to achieve the required pressure differential.

**B-8.2 AC.** Air Change is the minimum total air changes per hour (AC/H) required to meet ventilation requirements. These rates are considered the minimum required for normal health and comfort consideration. Additional air may be required for

temperature, dilution, and odor control, as well as air requirements for such items as hoods, glove boxes, clean-air stations, combustion equipment, and dust collectors.

- a Letter “a” indicates that the total air changes must be based on calculations
- r Letter “r” indicates the HVAC Notes provide the required minimum air change.

B-8.3 OA. Outside Air is the minimum outside air changes per hour required to meet ventilation requirements.

- a Letter “a” Indicates that the outdoor air changes are to be based on ANSI/ASHRAE 62.

B-8.4 TEMP. Interior design temperature in degrees Fahrenheit (F) for cooling and heating load calculations. When cooling is required during winter, such as in interior zones, temperature listed under summer conditions should be used.

- SM Design temperature for summer months.
- WN Design temperature for the space during heating season.
- \* Summer Design Temperature must be 15 degrees F less than 1 percent Outside Design Temperature but must not be less than 75 degrees F or greater than 78 degrees F unless otherwise noted.
- R Design must accommodate a variable (to user) temperature range of 68–75 degrees F
- SP Special. Determined by the Design and Construction Agent.

B-8.5 RH. Relative Humidity. This is the relative humidity to be maintained in a space as part of the designed conditions. Relative humidity range is 30–60 percent unless noted otherwise.

- Y Provide relative humidity range of 30-60 percent
- R Provide a user adjustable humidistat in the space, accommodating a variable humidity range of 30-60 percent
- S Maintain relative humidity of 20-60 percent. Design to provide minimum 30% RH
- T Maintain relative humidity of 55 percent, +/-5 percent.

B-8.6 FL. Filtration indicates the level and location of filtration required. See HVAC Note B.



IN. Intermediate filtration in MERV.

FN. Final filtration in MERV.

r. Letter “r” indicates that the HVAC Notes provide the required filtration.

B-8.7 EX. Exhaust.

Y Indicates room air to be exhausted, not recirculated.

r See HVAC Notes.

B-8.8 HVAC Notes.

A. Nursery Isolation Room relative pressurization requirements may vary among individual facilities, depending upon functional requirements. A/E's must coordinate with the Using Agency for each facility to determine whether disease isolation (negative pressurization) or protective isolation (positive pressurization) is required.

B. General Filtration. Filter efficiencies noted here are in accordance with the *Minimum Efficiency Reporting Value (MERV)* ratings of ANSI/ASHRAE Standard 52.2. Filters with a MERV rating of 8 must be provided for all outdoor air. These filters must be located upstream of air-conditioning equipment. Intermediate Filters indicated in column “IN” must be located downstream of the supply fan. Final filters indicated in column “FN” must be located at air outlets or in close proximity to outlets (coordinate with the Using Agency). All filters should be installed to prevent leakage between the filter segments and between the filter and its supporting frame.

C. During periods of non-use, the air volume may be reduced to 6 air changes per hour, while maintaining the required air balance.

D. When the Using Agency intends the routine usage of nitrous oxide in the DTR, routine being defined as exceeding 5 hours per week, this criteria must apply:

DTR room air changes must be not less than 12 total AC/H.

The room must be totally exhausted.

Provide a minimum of one low-level exhaust register, sized to remove a minimum of 20 percent of the total room exhaust volume.

During period of non-use, air change rate may be reduced to 3 total AC/H.

- E. General, Isolation Rooms. For Airborne Infection Isolation Bedrooms, bedroom to be negative to anteroom, anteroom to be negative to corridor. For Protective Environment Bedrooms, bedroom to be positive to anteroom, anteroom to be positive to corridor.
- F. Minimum air change and pressure relationship is based on this room supporting both bronchoscopy and endoscopy procedures. If the facility CONOPS specifically states that this room is intended to provide both proctoscopy and endoscopy procedures, the minimum air change required is 10 AC/H and room exhaust is 10% more than the room supply. If the facility CONOPS specifically states that this room is intended to provide endoscopy procedures only, the minimum air change required is 6 AC/H and room exhaust is 10 percent more than the room supply.
- G. Design in accordance with NFPA 99.
- H. May require vehicle exhaust, carbon monoxide (CO) detection.
- I. Same as Note D, except the following:
  - During period of non-use, air change rate may be reduced to 5 total AC.
  - Positive pressurization must be maintained.
- J. For projects incorporating brace/appliance fitting or shop applications, evaluate room and equipment exhaust requirements for removal of toxic or flammable fumes and dust.
- K. Consult manufacturer recommendations for temperature requirements for electrical/electronic equipment. In humid climates, fan rooms must not be ventilated with unconditioned outside air.
- L. Up to 50 percent of supply air may be air that is transferred from administrative areas of the building.
- M. Provide exhaust or fume hoods, and localized exhaust as required.
- N. Verify computer heat load requirement.
- O. Provide adjustable (to user) humidistat within the room.
- P. Provide adjustable (to user) thermostat within the room.
- Q. HEPA filtration of room exhaust is required unless an exhaust reentrainment analysis (wind tunnel or computational fluid dynamics modelling) demonstrates sufficient separation from public

areas (e.g., sidewalks), building openings (e.g. windows, doors) and outside air intakes. Exhaust of tuberculosis (TB) isolation room, toilet, and anteroom to be by dedicated exhaust system, i.e., exhaust system serving only TB isolation room(s). Isolation room pressure to remain constant—not switchable from Disease Isolation mode to Protective Isolation mode, or vice versa.

- R. Consult Design and Construction Agent to determine if compliance with USP 797 and/or USP 800 is required. If compliance is required, design in accordance with the applicable USP(s). If not, then provide an air balance of “++”, a minimum of 4 air changes per hour, minimum MERV 13 intermediate filtration and room air can be recirculated.
- S. Pediatric and emergency waiting rooms use requirements for WRC02.
- T. Provide a minimum of one low-level exhaust register, sized to remove a minimum of 20 percent of the total room exhaust volume.
- U. Comply with UFC 4-010-01 requirements for mail room ventilation.
- V. Temperature and humidity must be user selected in the ranges specified. Once set, the temperature must not deviate from setpoint by more than 1 degree within a 10 minute period and the RH must not deviate from setpoint by more than 2 percent RH per 10 minute period. The temperature and RH must be maintained at all times (24/7/365). Also provide a fluorine gas detection system, alarms, and emergency exhaust system to evacuate the room in the event of a fluorine gas leak.
- W. Consult Design and Construction Agent to determine if compliance with USP 797 and/or USP 800 is required. If compliance is required, design in accordance with the applicable USP(s). If not, then provide an air balance of “-“, a minimum of 6 AC/H, and minimum MERV 13 intermediate filtration.
- X. Provide localized exhaust near all steam utilizing equipment loading and unloading doors.

Table B-1 Architectural and Engineering Design Criteria

Room Code	ROOM FUNCTION	ARCHITECTURAL					STRUCTURAL		ELECTRICAL				MEDICAL GAS AND VACUUM					MECHANICAL																
		C O I E	MATL & FIN	CLG	DR & VAR	NC	FLR	LIGHT	ES PWR	PW	LT	N	M	D	L	P	S	O	D	N	I	G	A	W	BL	AC	OA	SM	WNRH	IN	FN	EX	N	
AMB02	Ambulance Garage	N	CS	BPT	SSP	VAR	SP	45 MAX STC 50	A	50	.	.	LS	.	.	.	.	.	.	.	.	.	.	.	O	a	a	.	55	Y	.	.	Y	H
ANCW1	Anesthesia, Clean Workroom	4	US	GLG	AT2	8'-0"	3'-0"	30-40 STC 40	60	700	.	.	R	L	.	1	.	1	.	1	1	1	1	D	-	4	1.5	75	68	Y	14	.	Y	.
ANSW1	Anesthesia, Soiled Workroom	4	US	GLG	AT2	8'-0"	3'-0"	30-40 STC 40	60	300	.	.	R	L	.	.	.	.	.	.	.	.	.	.	-	6	2	75	68	Y	14	.	Y	.
APAM1	Appliance, Adjust / Modify	4	UT	GPT	AT1	8'-0"	4'-0"	30-45 STC 40	C	500	.	.	R	.	.	1	1	.	1	.	.	.	J	O	6	1.5*	70	Y	13	.	.	J,M	.	
APFB1	Appliance, Brace Shop	4	UT	GAF	AT1	8'-0"	4'-0"	30-80 STC 40	100	500	.	.	.	.	.	1	1	.	1	.	.	.	J	O	6	1.5*	70	Y	13	.	.	J,M	.	
APFR1	Appliance, Fitting Room	4	UT	GPT	AT1	8'-0"	3'-0"	30-45 STC 40	60	500	.	.	.	.	.	.	.	.	.	.	.	.	.	O	6	1.5*	70	Y	13	.	.	J,M	.	
APLA1	Appliance, Lamination / Molding	4	UT	GPT	AT1	8'-0"	4'-0"	30-45 STC 40	C	500	.	.	.	.	.	1	.	.	.	.	.	.	J	-	6	1.5*	70	Y	13	.	Y	J,M	.	
APMS1	Appliance, Machine Shop	4	UT	GPT	AT1	8'-6"	4'-0"	30-60 STC 40	D	500	.	.	.	.	.	1	.	1	.	.	.	J	-	6	1.5*	70	Y	13	.	Y	J,M	.		
APSH1	Appliance, Sewing / Shoe Shop	4	UT	GPT	AT1	8'-6"	4'-0"	30-60 STC 40	C	500	.	.	.	.	.	1	.	1	.	.	.	J	-	6	1.5*	70	Y	13	.	Y	J,M	.		
APWA1	Appliance, Welding Area	4	CS	GPT	AT1	8'-6"	4'-0"	30-45 STC 40	D	500	.	.	.	.	.	1	.	.	.	.	.	.	.	-	6	1.5*	70	Y	13	.	Y	J,M	.	
AUD01	Auditorium	N	CP	SSP	SSP	VAR	B	25-35 STC 50	100	300	A,H	500	.	.	.	.	.	.	.	.	.	.	O	a	a	*	68	Y	13	.	.	.	.	
AVB01	Projection Booth	N	SP	SPF	SPF	VAR	3'-0"	25-35 STC 50	60	300	.	.	.	.	.	.	.	.	.	.	.	.	O	a	a	*	68	Y	13	.	.	.	.	
BF000	Banking Facility (equipped by others)	N	SP	GPT	AT1	8'-6"	A	35-45 STC 40	60	500	.	1100	.	.	.	.	.	.	.	.	.	.	O	a	a	*	68	Y	13	.	.	.	.	
BF001	ATM Alcove (equipped by others)	Space Parameter Notes: a and c																																
BHVS1	Behavioral Health, Vestibule, Inpatient	4	UT	GPT	GPT	8'-6"	G	30-40 STC 45	60	300	.	.	.	.	.	.	.	.	.	.	.	.	O	6	2	*	68	Y	14	.	.	.	.	
BLND1	Special Needs Vendor Area (equipped by others)	N	SP	SSP	SSP	VAR	3'-0"	35-45 STC 45	60	500	.	.	.	.	.	.	.	.	.	.	.	.	.	.	.	4	1	*	68	Y	13	.	.	.
BMCW1	Biomedical, Common Work Area	4	US	GPT	AT1	8'-6"	4'-0"	35-45 STC 40	C	500	.	.	.	.	.	1	.	1	.	1	1	1	D	O	4	1	*	68	Y	13	.	.	M	.
BMCW2	Biomedical Work Area, All-Inclusive	4	US	GPT	AT1	8'-6"	4'-0"	35-45 STC 40	C	500	.	.	.	.	.	1	.	1	.	1	1	1	D	O	4	1	*	68	Y	13	.	.	M	.
BMER1	Biomedical, Electronic Repair	4	US	GPT	AT1	8'-6"	4'-0"	35-45 STC 40	C	1100	.	.	.	.	.	1	.	1	.	1	1	1	D	-	4	1	*	68	Y	13	.	.	M	.
BMER2	Biomedical, Mobile Imaging Equipment Repair	4	US	LLG	AT1	8'-6"	4'-0"	35-45 STC 40	C	1100	.	.	.	.	.	1	.	1	.	1	1	1	D	O	4	1	*	68	Y	13	.	.	M	.
BMRA1	Biomedical, Receiving Area	4	US	GPT	AT1	8'-6"	4'-0"	35-45 STC 40	60	300	.	.	.	.	.	.	.	.	.	.	.	.	.	O	4	1	*	68	Y	13	.	.	.	.
BMWS1	Biomedical, Workstation	4	US	GPT	AT1	8'-6"	4'-0"	35-45 STC 40	60	1100	.	.	.	.	.	1	.	1	.	1	1	1	D	O	4	1	*	68	Y	13	.	.	M	.
BRAR1	Anteroom, Airborne Infection Isolation	4	US	GPT	GPT	8'-6"	4'-0"	30-40 STC 45	60	300	.	.	L	.	.	.	.	.	.	.	.	.	.	-	10	2	75	75	Y	14	.	Y	E,Q	.



Room Code	ROOM FUNCTION	ARCHITECTURAL					STRUCTURAL			ELECTRICAL			MEDICAL GAS AND VACUUM					MECHANICAL																							
		C/O	MATL & FIN		NC	FLR	LD	LGT	LEV	N	ES	PWR	LT	N	M	D	L	P	M	S	O	D	N	I	G	W	A	TEMP													
			FL	WL																								CLG	DR	&	SIZ	STC	MD	LA	AV	VE	EO	AD	N	BL	AC
CLR07	Classroom, Simulation Lab, Multifunction	N	UT	GPT	AT1	8'-6"	4'-0"	25-35	100	700	A	.	.	.	.	.	.	.	.	.	.	.	.	.	.	.	.	.	O	a	a	*	70	Y	13	.	.	.	.		
CLR08	Classroom, Practical Training	N	UT	GPT	AT1	8'-6"	4'-0"	25-35	60	700	A	.	.	.	.	.	.	.	.	.	.	.	.	.	.	.	.	.	O	a	a	*	70	Y	13	.	.	.	.		
CLSC1	Kiosk, Patient	Space Parameter Notes: a																																							
CLSC2	Cubicle, Patient Education	Space Parameter Notes: a																																							
CLSC3	Patient Education	N	CP	GPT	AT1	8'-0"	3'-0"	30-40	60	500	A	.	.	.	.	.	.	.	.	.	.	.	.	.	.	.	.	.	.	.	.	.	.	.	.	.	.	.	.		
CMP01	Server Room	N	CS	GPT	AT1	10'-0"	3'-0"	30-40	C	500	.	R	.	U	.	.	.	.	.	.	.	.	.	.	.	.	.	.	.	.	.	.	.	.	.	.	.	.	.	.	N
CMP03	Computer, Archive Storage	4	CS	GPT	AT1	10'-0"	3'-0"	30-40	D	500	.	.	.	U	.	.	.	.	.	.	.	.	.	.	.	.	.	.	.	.	.	.	.	.	.	.	.	.	.	.	N
CMP04	Communications, Server Support Equipment	4	CS	GPT	EXP	B	3'-0"	30-40	C	500	.	R	.	U	.	.	.	.	.	.	.	.	.	.	.	.	.	.	.	.	.	.	.	.	.	.	.	.	.	.	N
COM02	Communications, Ambulance Dispatch	4	UT	GPT	AT1	8'-0"	3'-0"	30-40	60	200	.	.	.	L	E	.	.	.	.	.	.	.	.	.	.	.	.	.	.	.	.	.	.	.	.	.	.	.	.	.	
COM03	Communications, Security, Central Alarm	4	UT	GPT	AT1	8'-0"	3'-0"	25-35	60	200	.	R	.	L	.	.	.	.	.	.	.	.	.	.	.	.	.	.	.	.	.	.	.	.	.	.	.	.	.	.	
COM04	Communications, Radio Equipment	4	CS	GPT	EXP	C	3'-0"	25-45	C	500	.	R	.	LS	.	.	.	.	.	.	.	.	.	.	.	.	.	.	.	.	.	.	.	.	.	.	.	.	.	N	
COMC1	Communications Room	4	CS	GPT	EXP	C	3'-0"	25-45	B	500	.	R	.	LS	.	.	.	.	.	.	.	.	.	.	.	.	.	.	.	.	.	.	.	.	.	.	.	.	.	N	
COMC2	Communications, Service Entrance Facility	4	CS	GPT	EXP	C	3'-0"	25-45	C	500	.	R	.	LS	.	.	.	.	.	.	.	.	.	.	.	.	.	.	.	.	.	.	.	.	.	.	.	.	.	N	
CRA01	Conference Room, Small	N	CP	GPT	AT1	8'-6"	3'-0"	25-35	60	300	.	.	.	.	.	.	.	.	.	.	.	.	.	.	.	.	.	.	.	.	.	.	.	.	.	.	.	.	.	P	
CRA02	Conference Room, Medium	N	CP	GPT	AT1	8'-6"	3'-0"	25-35	60	300	.	.	.	.	.	.	.	.	.	.	.	.	.	.	.	.	.	.	.	.	.	.	.	.	.	.	.	.	.	P	
CRA03	Conference Room, Large	N	CP	GPT	AT1	8'-6"	3'-0"	25-35	60	300	.	.	.	.	.	.	.	.	.	.	.	.	.	.	.	.	.	.	.	.	.	.	.	.	.	.	.	.	.	P	
CRC01	Conference Room, Commanders	N	CP	GPT	AT1	8'-6"	3'-0"	25-35	60	300	.	.	.	.	.	.	.	.	.	.	.	.	.	.	.	.	.	.	.	.	.	.	.	.	.	.	.	.	.	P	
CR0P1	Conference Room, Emergency Operations	4	SP	GPT	AT1	8'-6"	3'-0"	25-35	60	300	.	.	.	L	U	.	.	.	.	.	.	.	.	.	.	.	.	.	.	.	.	.	.	.	.	.	.	.	P		
CRR01	Conference Room, Radiology	N	CP	GPT	AT1	8'-6"	3'-0"	25-35	60	500	A	.	.	.	.	.	.	.	.	.	.	.	.	.	.	.	.	.	.	.	.	.	.	.	.	.	.	.	P		
CSCQ1	Central Sterile, Clean Cart, Queing	4	US	GLG	GLG	9'-0"	4'-0"	30-50	100	50	.	.	.	.	.	.	.	.	.	.	.	.	.	.	.	.	.	.	.	.	.	.	.	.	.	.	.	.	.	.	
CSCR1	Central Sterile, Soiled Cart, Receiving	4	US	GLG	GLG	9'-0"	4'-0"	30-50	100	100	.	.	.	.	.	.	.	.	.	.	.	.	.	.	.	.	.	.	.	.	.	.	.	.	.	.	.	.	.	Y	
CSDE1	Central Sterile, Decontamination, Small	4	US	GLG	GLG	9'-0"	4'-0"	30-50	100	700	.	.	.	LS	U	.	.	.	.	.	.	.	.	.	.	.	.	.	.	.	.	.	.	.	.	.	.	.	Y		
CSDE2	Central Sterile, Decontamination, Medium	4	US	GLG	GLG	9'-0"	4'-0"	30-50	100	700	.	.	.	LS	U	.	.	.	.	.	.	.	.	.	.	.	.	.	.	.	.	.	.	.	.	.	.	.	Y		

Room Code	ROOM FUNCTION	ARCHITECTURAL				STRUCTURAL		ELECTRICAL				MEDICAL GAS AND VACUUM						MECHANICAL														
		C/O	MATL & FIN		NC	FLR	LD	L I G H T	E S P W R	P W	L T N	M D L P M S O D N	I G	W A	T E M P																	
			I D	CLG											DR &	M	A	V	E	O	O	A	D	N	B L A C	O A	S M	W N R H	I N	F N	E X	N
				WL											S I Z E																	
CSDE3	Central Sterile, Decontamination, Large	4	US GLG	GLG 9'-0"	4'-0"	30-50	100	700	. . . . .	. . . . .	. . . . .	. . . . .	. . . . .	. . . . .	. . . . .	. . . . .	-	10	2	73	68	Y	14	. . . . .	Y	.						
CSIA1	Central Sterile, Assembly, Small	4	US GLG	GLG 9'-0"	4'-0"	30-50	100	700	. . . . .	. . . . .	. . . . .	. . . . .	. . . . .	. . . . .	. . . . .	. . . . .	+	6	2	73	68	Y	14	. . . . .	.	.						
CSIA2	Central Sterile, Assembly, Medium	4	US GLG	GLG 9'-0"	4'-0"	30-50	100	700	. . . . .	. . . . .	. . . . .	. . . . .	. . . . .	. . . . .	. . . . .	. . . . .	+	6	2	73	68	Y	14	. . . . .	.	.						
CSIA3	Central Sterile, Assembly, Large	4	US GLG	GLG 9'-0"	4'-0"	30-50	100	700	. . . . .	. . . . .	. . . . .	. . . . .	. . . . .	. . . . .	. . . . .	. . . . .	+	6	2	73	68	Y	14	. . . . .	.	.						
CSSS1	Central Sterile, Sterilization, Small	4	US GLG	GLG 9'-0"	4'-0"	30-50	100	700	. . . . .	. . . . .	. . . . .	. . . . .	. . . . .	. . . . .	. . . . .	. . . . .	-	10	2	73	68	Y	14	. . . . .	Y	M						
CSSS2	Central Sterile, Sterilization, Medium	4	US GLG	GLG 9'-0"	4'-0"	30-50	100	700	. . . . .	. . . . .	. . . . .	. . . . .	. . . . .	. . . . .	. . . . .	. . . . .	-	10	2	73	68	Y	14	. . . . .	Y	M						
CSSS3	Central Sterile, Sterilization, Large	4	US GLG	GLG 9'-0"	4'-0"	30-50	100	700	. . . . .	. . . . .	. . . . .	. . . . .	. . . . .	. . . . .	. . . . .	. . . . .	-	10	2	73	68	Y	14	. . . . .	Y	M						
CSSS4	Clinic Sterilization Room, Ophthalmological Instrument	4	US GLG	GLG 9'-0"	4'-0"	30-50	100	700	. . . . .	. . . . .	. . . . .	. . . . .	. . . . .	. . . . .	. . . . .	. . . . .	-	10	2	*	68	Y	14	. . . . .	Y	M						
CSWS1	Central Sterile, Scope / Wash	4	US GLG	GLG 9'-0"	4'-0"	30-50	100	700	. . . . .	. . . . .	. . . . .	. . . . .	. . . . .	. . . . .	. . . . .	. . . . .	-	10	2	*	68	Y	14	. . . . .	Y	M						
CWSH1	Cart Wash, Manual (Steam Gun)	4	PS GCT	GLG 9'-0"	4'-0"	30-50	100	300	. . . . .	. . . . .	. . . . .	. . . . .	. . . . .	. . . . .	. . . . .	. . . . .	-	10	2	*	68	Y	14	. . . . .	Y	M						
CWSH2	Cart Wash, Automated (Washer)	4	PS GCT	GLG 9'-0"	4'-0"	30-50	C	300	. . . . .	. . . . .	. . . . .	. . . . .	. . . . .	. . . . .	. . . . .	. . . . .	-	10	2	*	68	Y	14	. . . . .	Y	M						
DAYR1	Dayroom	3	SV GPT	AT1 8'-6"	4'-0"	30-40	60	150	. . . . .	. . . . .	. . . . .	. . . . .	. . . . .	. . . . .	. . . . .	. . . . .	O	6	2	*	68	Y	14	. . . . .	.	.						
DNMS1	Dental, Model Storage	4	US GLG	GAT1 8'-6"	3'-0"	30-50	60	700	. . . . .	. . . . .	. . . . .	. . . . .	. . . . .	. . . . .	. . . . .	. . . . .	O	a	a	*	68	Y	13	. . . . .	.	.						
DNPB1	Dental, Prosthodontic / Orthodontic, Laboratory	4	US GLG	GAT1 8'-6"	3'-0"	30-45	60	700	. . . . .	. . . . .	. . . . .	. . . . .	. . . . .	. . . . .	. . . . .	. . . . .	. . . . .	-	6	2	*	68	Y	13	. . . . .	Y	M					
DNPC1	Dental, Porcelain / Ceramics, Small	4	US GLG	GAT1 8'-6"	3'-0"	30-45	60	700	. . . . .	. . . . .	. . . . .	. . . . .	. . . . .	. . . . .	. . . . .	. . . . .	+	10	2.5	*	68	Y	13	. . . . .	Y	M						
DNPC2	Dental, Porcelain / Ceramics, Medium	4	US GLG	GAT1 8'-6"	3'-0"	30-50	60	700	. . . . .	. . . . .	. . . . .	. . . . .	. . . . .	. . . . .	. . . . .	. . . . .	+	10	2.5	*	68	Y	13	. . . . .	Y	M						
DNPC3	Dental, Porcelain / Ceramics, Large	4	US GLG	GAT1 8'-6"	3'-0"	30-50	60	700	. . . . .	. . . . .	. . . . .	. . . . .	. . . . .	. . . . .	. . . . .	. . . . .	+	10	2.5	*	68	Y	13	. . . . .	Y	M						
DNPL1	Dental, Prosthodontic Laboratory, Small	4	US GLG	GAT1 8'-6"	3'-0"	30-50	60	700	. . . . .	. . . . .	. . . . .	. . . . .	. . . . .	. . . . .	. . . . .	. . . . .	-	10	2.5	*	68	Y	13	. . . . .	Y	M						
DNPL2	Dental, Prosthodontic Laboratory, Medium	4	US GLG	GAT1 8'-6"	3'-0"	30-50	60	700	. . . . .	. . . . .	. . . . .	. . . . .	. . . . .	. . . . .	. . . . .	. . . . .	-	10	2.5	*	68	Y	13	. . . . .	Y	M						
DNPL3	Dental, Prosthodontic Laboratory, Large	4	US GLG	GAT1 8'-6"	3'-0"	30-50	60	700	. . . . .	. . . . .	. . . . .	. . . . .	. . . . .	. . . . .	. . . . .	. . . . .	-	10	2.5	*	68	Y	13	. . . . .	Y	M						
DNSC1	Dental, Instrument Decontamination, Small	4	US GLG	GLG 8'-6"	3'-0"	30-45	60	700	. . . . .	. . . . .	. . . . .	. . . . .	. . . . .	. . . . .	. . . . .	. . . . .	-	10	2	73	68	Y	14	. . . . .	Y	.						
DNSC2	Dental, Instrument Sterilization, Small	4	US GLG	GLG 8'-6"	3'-0"	30-45	60	700	. . . . .	. . . . .	. . . . .	. . . . .	. . . . .	. . . . .	. . . . .	. . . . .	++	6	2	73	68	Y	14	. . . . .	.	X						
DNSC3	Dental, Instrument Storage, Small	4	US GLG	GLG 8'-6"	3'-0"	30-50	60	700	. . . . .	. . . . .	. . . . .	. . . . .	. . . . .	. . . . .	. . . . .	. . . . .	++	6	2	75	68	Y	13	. . . . .	.	X						

Room Code	ROOM FUNCTION	C/O	ARCHITECTURAL					STRUCTURAL				ELECTRICAL				MEDICAL GAS AND VACUUM					MECHANICAL																		
			MATERIAL & FIN		CLG DR & NC		FLR	LD	LIGHT	LEV	N	ES	PWR	PW	LT	N	M	D	L	P	M	S	O	D	N	I	G	W	A	N	B	BLAC	OA	SM	WNRH	IN	FN	EX	N
			FL	WL	CLG	DR																																	
DNSC4	Dental, Instrument Decontamination, Medium	4	US	GLG	GLG	8'-6"	3'-0"	30-50	60	700	.	.	.	U	.	1	.	.	.	.	.	.	.	.	.	.	.	B	--	10	2	73	68	Y	13	.	Y	.	
DNSC5	Dental, Instrument Sterilization, Medium	4	US	GLG	GLG	8'-6"	3'-0"	30-50	60	700	.	.	.	U	.	1	.	.	.	.	.	.	.	.	.	.	.	B	++	6	2	73	68	Y	13	.	.	X	
DNSC6	Dental, Instrument Storage, Medium	4	US	GLG	GLG	8'-6"	3'-0"	30-50	60	700	.	.	.	.	.	.	.	.	.	.	.	.	.	.	.	.	.	.	++	6	2	75	68	Y	13	.	.	X	
DNSC7	Dental, Instrument Decontamination, Large	4	US	GLG	GLG	8'-6"	3'-0"	30-50	60	700	.	.	.	U	.	1	.	.	.	.	.	.	.	.	.	.	.	B	--	10	2	73	68	Y	13	.	Y	.	
DNSC8	Dental, Instrument Sterilization, Large	4	US	GLG	GLG	8'-6"	3'-0"	30-50	60	700	.	.	.	U	.	1	.	.	.	.	.	.	.	.	.	.	.	B	++	6	2	73	68	Y	13	.	.	X	
DNSC9	Dental, Instrument Storage, Large	4	US	GLG	GLG	8'-6"	3'-0"	30-50	60	700	.	.	.	.	.	.	.	.	.	.	.	.	.	.	.	.	.	.	++	6	2	75	68	Y	13	.	.	X	
DNSS1	Dental, Support, Substerile	4	US	GLG	GAT	8'-6"	3'-0"	30-40	60	500	.	.	.	.	.	1	.	.	.	1	.	.	.	.	.	.	B	O	6	2	*	68	Y	13	.	.	.		
DNTB1	Dental Treatment Room, Orthodontic	3	US	GLG	GAT	8'-6"	3'-0"	30-40	60	1600	A,K	.	.	U	.	2	.	.	.	2	.	.	.	.	.	.	K	O	6	2	75	68	Y	14	.	.	.		
DNTC1	Dental Treatment Room, Comprehensive	2	US	GLG	GAT	8'-6"	3'-0"	30-40	60	2100	A,D,K	R	LB	U	.	2	.	.	1	2	.	1	1	1	1	D,K	++	12	3	75	68	Y	14	.	.	I			
DNTE1	Dental Treatment Room, Endodontic	3	US	GLG	GAT	8'-6"	3'-0"	30-40	60	1600	A,K	.	.	U	.	2	.	.	1	2	.	1	1	1	D,K	O	6	2	75	68	Y	14	.	.	I				
DNTG1	Dental Treatment Room, General	3	US	GLG	GAT	8'-6"	3'-0"	30-40	60	1600	A,K	.	.	U	.	2	.	.	.	2	.	.	.	.	.	.	K	O	6	2	75	68	Y	14	.	.	D		
DNTG2	Dental Treatment Room, Oral Hygiene	3	US	GLG	GAT	8'-6"	3'-0"	30-40	60	1600	A,K	.	.	U	.	2	.	.	.	2	.	.	.	.	.	.	K	O	6	2	75	68	Y	14	.	.	D		
DNTG3	Dental Treatment Room, Two Chair	3	US	GLG	GAT	8'-6"	3'-0"	35-45	60	1600	A,K	.	.	U	.	2	.	.	.	2	.	.	.	.	.	.	K	O	6	2	75	68	Y	14	.	.	D		
DNTG4	Dental Treatment Room, Multi-Chair	3	US	GLG	GAT	8'-6"	3'-0"	35-45	60	1600	A,K	.	.	U	.	2	.	.	.	2	.	.	.	.	.	.	K	O	6	2	75	68	Y	14	.	.	D		
DNTP1	Dental Treatment Room, Prosthodontic	3	US	GLG	GAT	8'-6"	3'-0"	30-40	60	1600	A,K	.	.	U	.	2	1	.	.	2	.	.	.	.	.	K,L	O	6	2	75	68	Y	14	.	.	D			
DNTP2	Dental Treatment Room, Periodontic	2	US	GLG	GAT	8'-6"	3'-0"	30-40	60	2100	A,D,K	R	LB	U	.	2	.	.	1	2	.	1	1	1	1	D,K	++	12	3	68	75	Y	14	.	.	I			
DNTR1	Dental, Recovery	3	US	GLG	GAT	8'-6"	3'-6"	30-40	60	300	.	.	.	.	.	.	.	.	.	.	.	.	.	.	.	.	.	.	+	6	2	75	68	Y	14	.	.	.	
DNTS1	Dental Treatment Room, Oral Surgery	2	US	GLG	GLG	8'-6"	3'-6"	30-40	60	2100	A,D,K	R	LB	U	.	2	.	.	1	2	.	1	1	1	1	D	++	12	3	68	78	Y	14	.	.	I			
DNTS2	Dental Treatment Room, Oral Surgery Support	4	US	GLG	GAT	8'-6"	3'-6"	30-40	60	700	.	.	.	.	.	.	.	.	.	.	.	.	.	.	.	.	.	.	O	6	2	75	68	Y	14	.	.	.	
DNTT1	Dental Treatment Room, Training	3	US	GLG	GAT	8'-6"	3'-0"	30-40	60	1600	A	.	.	.	.	.	.	.	.	2	.	.	.	.	.	.	K	O	6	2	75	68	Y	14	.	.	D		
DNXC1	Dental X-Ray, Cone Beam CT	3	UT	LPT	AT	8'-6"	3'-6"	30-40	60	100	.	.	.	.	.	.	.	.	.	.	.	.	.	.	.	.	.	.	O	6	2	75	68	Y	14	.	.	.	
DNXR1	Dental X-Ray, PACS	N	UT	GPT	AT	8'-0"	3'-0"	30-40	60	300	.	.	.	.	.	.	.	.	.	.	.	.	.	.	.	.	.	.	O	6	2	75	68	Y	14	.	.	.	
DNXS1	Dental X-Ray, Intraoral / Panoramic / Cephalometric	3	UT	GPT	AT	8'-6"	3'-6"	30-40	60	300	.	.	.	.	.	.	.	.	.	.	.	.	.	.	.	.	.	.	O	6	2	75	68	Y	14	.	.	.	



Room Code	ROOM FUNCTION	C/O ID	ARCHITECTURAL				STRUCTURAL		ELECTRICAL				MEDICAL GAS AND VACUUM							MECHANICAL																				
			M&F		NC		FLR	LD	L	LEV	ES	PWR	M	D	L	P	S	O	D	N	I	G	W	A	BLAC	OA	SM	WNR	H	IN	FN	EX	N							
			FL	WL	CLG	DR																												&	STC	HT	SZ	CLG	DR	SZ
DOCK1	Loading Dock	N	CS	SSP	SSP	VAR																																		
DR001	Dressing Room / Cubicle	4	CP	GPT	AT1	8'-0	3'-0	25-40	60	100																														
DUTY1	On-Call Room	N	CP	GPT	AT1	8'-0	3'-0	30-40	60	300																														
EVPR1	Evoked Potential Response	3	UT	GPT	AT1	8'-0	3'-0	30-40	100	500	A																													
EXB01	Exam, Bariatric	3	UT	GPT	AT1	8'-0	3'-6	30-40	E	300																														
EXEB1	Exam / Treatment, Emergency Department, Bariatric	2	US	GLG	GLG	8'-0	H	30-40	E	500		R	LB	1			1			1																				
EXEN1	Exam, ENT	3	UT	GPT	AT1	8'-0	3'-0	30-40	60	300																														
EXEN2	Exam / Treatment, Emergency Department, ENT	2	US	GLG	GLG	8'-0	H	30-40	60	500		R	LB	1			1			1																				
EXER1	Exam / Treatment, Emergency Room	2	US	GLG	GLG	8'-0	H	30-40	60	500		R	LB	1			1			1																				
EXER2	Exam / Treatment, Emergency Department, Airborne Infection Isolation	2	US	GLG	GLG	8'-0	4'-0	30-40	60	500		R	LB	1			1			1							--	12	2	*	73	Y	14		Y	Q				
EXOS1	Exam, Speech-Language Pathology	3	CP	GPT	AT1	8'-0	3'-0	30-40	60	300																														
EXP01	Exam, Podiatry	3	UT	GPT	AT1	8'-0	3'-0	30-40	60	300																														
EXR10	Exam, Consult	3	UT	GPT	AT1	8'-0	3'-0	30-40	60	300																														
EXR11	Alcove, Height / Weight	Space Parameter Notes: a																																						
EXRG1	Exam	3	UT	GPT	AT1	8'-0	3'-0	30-40	60	300																														
EXRG4	Exam, Screening	3	UT	GPT	AT1	8'-0	3'-0	30-40	60	300																														
EXRG5	Exam, Screening, Height/Weight, Alcove	Space Parameter Notes: a																																						
EXRG6	Exam, Airborne Infection Isolation	3	US	GLG	GLG	8'-0	3'-0	30-40	60	300																		--	12	2	*	73	Y	14		Y	Q			
EXRG7	Exam, Protective Environment	3	US	GLG	GLG	8'-0	3'-0	30-40	60	300																														
EXRG8	Exam, OB / GYN	3	US	GPT	AT1	8'-0	3'-6	30-40	60	300																														
EXRG9	Exam, Forensics	3	US	GLG	GAT1	8'-0	3'-6	30-40	60	300																														
EXTH1	Exam, Telehealth	3	UT	GPT	AT1	8'-0	3'-0	30-40	60	300																														
EXUD1	Exam, Uroynamics	3	US	GPT	AT1	8'-0	3'-0	30-40	60	300																														

Room Code	ROOM FUNCTION	C/O	ARCHITECTURAL				STRUCTURAL		ELECTRICAL			MEDICAL GAS AND VACUUM					MECHANICAL																
			MATL & FIN		NC		FLR	LD	LIGHT	ES	PWR	M	D	L	P	S	O	D	N	I	G	W	A	BL	AC	OA	SM	WNR	RH	IN	FN	EX	N
			FL	WL	CLG	DR & SIZE																											
EXVE1	Exam, Vestibular	3	UT	GPT	AT1	8'-0"	3'-0"	25-35	60	500	A												O	6	2	*	73	Y	14				
EYCL1	Eye, Contact Lens Fitting / Dispensing	3	UT	GPT	AT1	8'-0"	3'-0"	30-40	60	500													O	6	2	*	68	Y	14				
EYCT1	Eye, Diagnostic, Optical Coherence Tomography	3	UT	GPT	AT1	8'-0"	3'-0"	30-40	60	200	A												O	6	2	*	68	Y	14				
EYCT2	Eye, Procedure, Optical Coherence Tomography	2	UT	GPT	AT1	8'-0"	3'-0"	30-40	60	200	A												O	6	2	*	68	Y	14				
EYEL1	Eyelane	3	UT	GPT	AT1	8'-0"	3'-0"	30-40	60	200	H												O	6	2	*	68	Y	14				
EYEL2	Eye Lane, Electronic	3	UT	GPT	AT1	8'-0"	3'-0"	30-40	60	200	H												O	6	2	*	68	Y	14				
EYER1	Eye, Electroretinography	3	UT	GPT	AT1	8'-0"	3'-0"	30-40	60	200	A												O	6	2	*	68	Y	14				
EYFC1	Eye, Fundus Camera	3	UT	GPT	AT1	8'-0"	3'-0"	30-40	60	200	A												O	6	2	*	68	Y	14				
EYFD1	Eyeglass, Fitting and Dispensing	3	UT	GPT	AT1	8'-0"	3'-0"	30-40	60	500													O	4	2	*	68	Y	14				
EYOF1	Eye, Laboratory, Optical Fabrication	4	UT	GPT	AT1	8'-0"	3'-0"	30-40	60	500	F												-	6	2	*	68	Y	13		Y	M	
EYOT2	Eye, Exam, Ophthalmology	3	UT	GPT	AT1	8'-0"	3'-0"	30-40	60	200	A												O	6	2	*	68	Y	14				
EYOT3	Eye, PRK / LASIK Evaluation	3	UT	GPT	AT1	8'-0"	3'-0"	30-40	60	500	A	RA	LB										O	6	2	*	68	Y	14				
EYVF1	Eye, Visual Field / Perimetry	3	UT	GPT	AT1	8'-0"	3'-0"	30-40	60	200	A												O	6	2	*	68	Y	14				
EYVS1	Eye, Vision Screening	3	UT	GPT	AT1	8'-0"	3'-0"	30-40	60	500	F												O	6	2	*	68	Y	14				
FILE1	File, General Use	N	UT	GPT	AT1	8'-0"	3'-0"	30-40	150	150													O	a	a	*	68	Y	13				
FGBR1	Food Service, Bake and Roast Center	N	PS	GLG	GLG	9'-0"	B	30-45	F	700													O	10	2	*	68	Y	13		Y	M	
FSCB1	Food Service, Carbonated Beverage	N	PS	GLG	GLG	9'-0"	B	30-45	F	200													O	10	2	*	68	Y	13				
FSCD1	Food Service, Cafeteria Dining Room	N	CP	GPT	AT1	9'-0"	B	30-45	F	200													O	12	2	*	68	Y	13				
FSCD2	Food Service, Executive Dining Area	N	CP	GPT	AT1	9'-0"	B	30-45	F	200													O	12	2	*	68	Y	13				
FSCN1	Food Service, Condiment Area	Space Parameter Notes: a																															
FSCS1	Food Service, Cart Storage	N	PS	GLG	GLG	9'-0"	3'-0"	30-45	F	200													O	4	2	*	68	Y	13				
FSCS2	Food Service, Tray Retherm Cart Area, Centralized	Space Parameter Notes: a																															
FSDA1	Food Service, Dessert Assembly	N	PS	GLG	GLG	9'-0"	3'-0"	30-45	F	700													O	10	2	*	68	Y	13				

Room Code	ROOM FUNCTION	C O I D	ARCHITECTURAL				STRUCTURAL		ELECTRICAL				MEDICAL GAS AND VACUUM						MECHANICAL											
			MATL & FIN		NC		FLR LD	LIGHT LEV N	ES PW	PWR LT N	M A	D A	L V	P V	S E	O O	D O	N A	I G	W A	BL	AC	OA	SM	WNRH	IN	FN	EX	N	
			FL	WL	CLG	DR & SIZ																								HT
FSDS1	Food Service, Dish Storage Area	N PS SF	GLG	GLG	9'-0"	3'-0"	30-45	F	200	.	.	.	.	.	.	.	.	.	.	.	O	4	2	*	68	Y	13	.	.	
FSDW1	Food Service, Dish Washing	N PS SF	GLG	GLG	9'-0"	3'-0"	30-45	F	500	.	.	.	.	.	.	.	.	.	.	.	-	10	2	*	68	Y	13	.	Y	M
FSDW2	Food Service, Dish / Tray Handling, Remote	N PS SF	GLG	GLG	9'-0"	3'-0"	30-45	F	500	.	.	.	.	.	.	.	.	.	.	.	-	10	2	*	68	Y	13	.	Y	M
FSFC1	Food Service, Fry Center	N PS SF	GLG	GLG	9'-0"	3'-0"	30-45	F	700	.	.	.	.	.	.	.	.	.	.	.	-	10	2	*	68	Y	13	.	Y	M
FSFPX	Food Preparation / Production Areas	N PS SF	GLG	GLG	9'-0"	3'-0"	30-45	F	700	.	.	.	.	.	.	.	.	.	.	.	-	10	2	*	68	Y	13	.	Y	M
FSFV1	Food Service, Fresh Fruit / Vegetable	N PS SF	GLG	GLG	9'-0"	3'-0"	30-45	F	700	.	.	.	.	.	.	.	.	.	.	.	O	10	2	*	68	Y	13	.	.	.
FSGB1	Food Service, Grill and Broil Area	N PS SF	GLG	GLG	9'-0"	3'-0"	30-45	F	700	.	.	.	.	.	.	.	.	.	.	.	-	10	2	*	68	Y	13	.	Y	M
FSIR1	Food Service, Ingredient Room	N PS SF	GLG	GLG	9'-0"	3'-0"	30-45	F	150	.	.	.	.	.	.	.	.	.	.	.	O	10	2	*	68	Y	13	.	.	.
FSMC1	Food Service, Mixing Center	N PS SF	GLG	GLG	9'-0"	3'-0"	30-45	F	700	.	.	.	.	.	.	.	.	.	.	.	O	10	2	*	68	Y	13	.	.	.
FSMP1	Food Service, Meat Processing	N PS SF	GLG	GLG	9'-0"	3'-0"	30-45	F	700	.	.	.	.	.	.	.	.	.	.	.	O	10	2	*	68	Y	13	.	.	.
FSNP1	Food Service, Nourishment Preparation Area	N PS SF	GLG	GLG	9'-0"	3'-0"	30-45	F	500	.	.	.	.	.	.	.	.	.	.	.	O	10	2	*	68	Y	13	.	.	.
FSPP1	Food Service, Pastry Preparation	N PS SF	GLG	GLG	9'-0"	3'-0"	30-45	F	700	.	.	.	.	.	.	.	.	.	.	.	O	10	2	*	68	Y	13	.	.	.
FSPT1	Food Service, Patient Tray Line	N PS SF	GLG	GLG	9'-0"	3'-0"	30-45	F	700	.	.	.	.	.	.	.	.	.	.	.	O	10	2	*	68	Y	13	.	.	.
FSPT2	Food Service, Patient Tray Carousel	N PS SF	GLG	GLG	9'-0"	3'-0"	30-45	F	150	.	.	.	.	.	.	.	.	.	.	.	O	10	2	*	68	Y	13	.	Y	.
FSPW1	Food Service, Pot Washing	N PS SF	GLG	GLG	9'-0"	3'-0"	30-45	F	300	.	.	.	.	.	.	.	.	.	.	.	-	10	2	*	68	Y	13	.	Y	M
FSRC1	Food Service, Rapid Chill / Freeze	N PS SF	GLG	GLG	9'-0"	3'-0"	30-45	F	500	.	.	.	.	.	.	.	.	.	.	.	O	10	2	*	68	Y	13	.	.	.
FSRH1	Food Service, Clean Pots / Pans Holding Area	N PS SF	GLG	GLG	9'-0"	3'-0"	30-45	F	500	.	.	.	.	.	.	.	.	.	.	.	O	10	2	*	68	Y	13	.	.	.
FSRT1	Food Service, Bulk Food Rethermalization	N PS SF	GLG	GLG	9'-0"	3'-0"	30-45	F	500	.	.	.	.	.	.	.	.	.	.	.	O	10	2	*	68	Y	13	.	.	.
FSSA1	Food Service, Salad Assembly	N PS SF	GLG	GLG	9'-0"	3'-0"	30-45	F	700	.	.	.	.	.	.	.	.	.	.	.	O	10	2	*	68	Y	13	.	.	.
FSSC1	Food Service, Steam Center	N PS SF	GLG	GLG	9'-0"	3'-0"	30-45	F	500	.	.	.	.	.	.	.	.	.	.	.	-	10	2	*	68	Y	13	.	Y	M
FSSLX	Food Service Servery Areas	N PS SF	GLG	GLG	9'-0"	3'-0"	30-45	F	500	.	.	.	.	.	.	.	.	.	.	.	O	12	2	*	68	Y	13	.	Y	.
FSSSX	Food Service Station Areas	N PS SF	GLG	GLG	9'-0"	3'-0"	30-45	F	500	.	.	.	.	.	.	.	.	.	.	.	O	12	2	*	68	Y	13	.	Y	M
FSTAX	Food Service, Tray Assembly Areas	N PS SF	GLG	GLG	9'-0"	3'-0"	30-45	F	700	.	.	.	.	.	.	.	.	.	.	.	-	10	2	*	68	Y	13	.	Y	.

Room Code	ROOM FUNCTION	ARCHITECTURAL			STRUCTURAL		ELECTRICAL			MEDICAL GAS AND VACUUM					MECHANICAL																																											
		C	MATL & FIN		NC		FLR	LD	LIGHT	ES	PWR	LT	N	M	D	L	P	S	O	D	N	I	G	W	A	D	N	BL	AC	OA	SM	W	N	R	H	IN	FN	EX	N																			
		ID	FL	WL	CLG	DR &																																		SIZES	STC	LEV	PW	LT	N	A	A	A	V	V	E	E	O	O	A	D	N	TEMP
		E																																																								
FSTD1	Food Service, Therapeutic Diet Preparation	N	PS	GLG	GLG	9'-0"	3'-0"	30-40	F	500	.	.	.	.	.	.	.	.	.	.	.	.	.	.	.	.	O	10	2	*	68	Y	13	.	.	.	Y	.	.																			
HAFR1	Hearing Aid Fitting	3	CP	GAF	AT1	8'-6"	3'-0"	20-25	60	500	.	.	.	.	.	.	.	.	.	.	.	.	.	.	.	O	6	2	*	68	Y	13	.	.	.	.	.	.	.																			
HATL1	Hearing Aid Testing Lab / Shop	4	UT	GPT	AT1	8'-6"	3'-0"	25-35	60	700	.	.	.	.	.	.	.	.	.	.	.	.	.	.	.	O	4	1	*	68	Y	13	.	.	.	.	.	.	.																			
HYPR1	Hyperbaric Chamber	C	SP	SSP	SSP	VAR	VAR	SP	100	300	B	1100	RA	LB	.	.	.	.	.	.	.	.	.	.	O	4	1	*	68	Y	13	.	.	.	.	.	.	.	.																			
ICE01	Alcove, Ice Machine	Space Parameter Notes: a, d and e																																																								
ICHT1	Alcove, Hydocolator	Space Parameter Notes: a																																																								
IPK01	Kitchenette	4	UT	GLG	GLG	VAR	3'-0"	35-45	150	500	.	.	.	.	.	.	.	.	.	.	.	.	.	.	.	O	4	2	*	68	Y	13	.	.	.	.	.	.	.																			
JANC1	Janitor's Closet	N	CS	GLG	GPT	8'-0"	3'-0"	35-45	100	50	.	.	.	.	.	.	.	.	.	.	.	.	.	.	.	-	10	.	.	.	Y	13	.	.	.	Y	.	.	.																			
KEY01	Key / Access Control	N	UT	GPT	AT1	8'-0"	3'-0"	30-40	60	500	.	.	.	.	.	.	.	.	.	.	.	.	.	.	.	O	a	a	*	68	Y	13	.	.	.	.	.	.	.																			
LAC01	Lactation Room	3	UT	GPT	AT1	8'-0"	3'-0"	30-40	60	500	A	.	.	.	.	.	.	.	.	.	.	.	.	.	.	O	6	2	*	73	Y	14	.	.	.	.	.	.	.																			
LAUN1	Laundry Room, Inpatient	N	UT	GLG	GLG	9'-0"	3'-0"	30-45	150	500	.	.	.	.	.	.	.	.	.	.	.	.	.	.	.	O	4	2	*	68	Y	13	.	.	.	.	.	.	.																			
LAUN2	Laundry Room, Inpatient, Behavioral Health	N	UT	GLG	GLG	9'-0"	3'-0"	30-45	150	500	.	.	.	.	.	.	.	.	.	.	.	.	.	.	.	O	4	2	*	68	Y	13	.	.	.	.	.	.	.																			
LBAL1	Laboratory, Automated, Small	4	US	GLG	GAT2	9'-0"	G	30-40	100	500	.	.	.	.	.	.	.	.	.	.	.	.	.	.	.	-	6	2	R	R	Y	13	.	.	.	Y	.	.	M																			
LBAL2	Laboratory, Automated, Medium	4	US	GLG	GAT2	9'-0"	G	30-40	100	500	.	.	.	.	.	.	.	.	.	.	.	.	.	.	.	-	6	2	R	R	Y	13	.	.	.	Y	.	.	M																			
LBAL3	Laboratory, Automated, Large	4	US	GLG	GAT2	9'-0"	G	30-40	100	500	.	.	.	.	.	.	.	.	.	.	.	.	.	.	.	-	6	2	R	R	Y	13	.	.	.	Y	.	.	M																			
LBAP1	Allergen Preparation	4	US	GPT	AT1	9'-0"	3'-0"	30-40	100	500	.	.	.	.	.	.	.	.	.	.	.	.	.	.	.	-	6	2	R	R	Y	14	14	.	.	.	.	M																				
LBAR1	Laboratory, Autopsy	4	ER	GLG	GLG	9'-0"	4'-0"	30-50	60	700	D	1600	.	.	.	.	.	.	.	.	.	.	.	.	.	-	12	3	R	R	Y	13	.	.	.	Y	.	.	M,T																			
LBBD1	Laboratory, Blood Donor Station	3	US	GLG	GAT2	8'-6"	4'-0"	35-45	60	750	.	.	.	LS	.	.	.	.	.	.	.	.	.	.	.	-	6	2	R	R	Y	14	.	.	.	.	.	.																				
LBBD2	Laboratory, Blood / Phoresis Processing	4	US	GLG	GAT2	9'-0"	3'-0"	30-45	100	500	.	.	.	R	L	.	.	.	.	.	.	.	.	.	.	-	6	2	R	R	Y	13	.	.	.	Y	.	.																				
LBBG2	Laboratory, Blood Gas	4	US	GLG	GAT2	9'-0"	3'-0"	30-45	100	500	.	.	.	R	L	.	.	.	.	.	.	.	.	.	.	-	6	2	R	R	Y	13	.	.	.	Y	.	.																				
LBBP1	Laboratory, Body Preparation	4	ER	GLG	GLG	9'-0"	4'-0"	30-50	100	500	.	.	.	.	.	.	.	.	.	.	.	.	.	.	.	-	10	2	R	R	Y	13	.	.	.	Y	.	.	M																			
LBBS1	Laboratory, Blood Shipping	4	US	GLG	GAT2	9'-0"	3'-0"	30-50	100	500	.	.	.	LS	E	.	.	.	.	.	.	.	.	.	.	-	6	2	R	R	Y	13	.	.	.	.	.	M																				
LBBS2	Laboratory, Blood Shipping - Frozen Blood	4	US	GLG	GAT2	9'-0"	3'-0"	30-50	100	500	.	.	.	LS	E	.	.	.	.	.	.	.	.	.	.	-	6	2	R	R	Y	13	.	.	.	.	.	M																				

Room Code	ROOM FUNCTION	C O D E	ARCHITECTURAL				STRUCTURAL		ELECTRICAL			MEDICAL GAS AND VACUUM					MECHANICAL																	
			MATL & FIN		NC		FLR LD	L E V E L N	E S P W R	P W L T N	M D L P M S O D N I G	A A A A V V E E O O A D N	W A I T I N G	B L A C	O A	TEMP				E X	N													
			FL	WL	CLG HT	DR & S I Z E										STC								R	S	M	W	N	R H	I N	F N			
LBVV1	Laboratory, Body Viewing	4	US	GLG	AT2	9'-0"	4'-0"	30-40	100	500	.								-	12	3	R	R	Y	13	.	Y	M						
LBEP1	Laboratory, Cytogenetics Preparation	4	US	GLG	AT2	9'-0"	3'-0"	30-50	100	500	.	R	L	.					-	6	2	R	R	Y	13	.	Y	M						
LBEC1	Laboratory, Cytogenetics Reading	4	UT	GPT	AT1	9'-0"	3'-0"	30-40	100	500	A	R	L	.					-	6	2	R	R	Y	13	.	Y	M						
LBDE1	Laboratory, Dermatology	4	UT	GPT	AT2	9'-0"	3'-0"	30-50	100	500	.								-	6	2	R	R	Y	13	.		M						
LBDR1	Laboratory, Decontamination	4	US	GLG	GLG	9'-0"	3'-0"	30-50	100	500	.	R	L	.		1	.	1	.	1	.	B			-	10	2	R	R	Y	13	.	Y	M
LBDS1	Laboratory, Bone Dissection (ENT Use)	4	US	GLG	AT2	9'-0"	3'-0"	30-50	100	500	.			U	.	1	.	1	.	.	.	B			-	6	2	R	R	Y	13	.	Y	M
LBEM2	Laboratory, Electron Microscope	4	US	GLG	AT2	9'-0"	3'-0"	30-45	100	500	A	R	L	.								O	6	2	R	R	Y	13	.					
LBEM3	Laboratory, Electron Microscope, Specimen Preparation	4	US	GLG	AT2	9'-0"	3'-0"	30-45	100	500	.	R	L	.								O	6	2	R	R	Y	13	.					
LBEN1	Laboratory, Entomology	4	US	GLG	AT2	9'-0"	3'-0"	30-45	100	500	.	R	L	.	.	1	.	1	.	.	.	B			-	6	2	R	R	Y	13	.	Y	M
LBFC1	Laboratory, Flow Cytometer	4	US	GLG	AT2	9'-0"	3'-0"	30-45	100	500	.	R	L	.								-	6	2	R	R	Y	13	.	Y	M			
LBGW1	Laboratory, Glassware Washing	4	US	GLG	GLG	9'-0"	3'-0"	30-50	100	200	.		L	.								-	10	2.5	R	R	Y	13	.	Y	M			
LBIH1	Laboratory, Industrial Hygiene	4	US	GLG	AT2	9'-0"	3'-0"	30-50	100	500	.											-	6	2	R	R	Y	13	.	Y	M			
LBIR1	Laboratory, Incubation Room, Walk-In	4	SP	GLG	GLG	9'-0"	3'-0"	30-50	100	500	.		LS	E								-	6	2	R	R	Y	13	.	Y	M			
LBMH1	Laboratory, Multi-Head Microscope and Collaboration Room	4	UT	GPT	AT1	8'-0"	3'-0"	30-50	100	500	A											O	6	2	R	R	Y	13	.					
LBMR1	Laboratory, Morgue Refrigerator	4	SP	GLG	GLG	9'-0"	SP	30-50	C	150	.		LS	E								-	10	2	SP	SP	Y	13	.	Y	.			
LBMR2	Laboratory, Morgue Refrigerator, Walk-In	4	SP	GLG	GLG	9'-0"	SP	30-50	C	150	.		LS	E								-		2	SP	SP	Y	13	.					
LBOB1	Laboratory, OB / GYN Clinic - Specimens	4	US	GLG	AT2	9'-0"	3'-0"	30-45	100	500	.	R	L	.								-	6	2	R	R	Y	13	.	Y	M			
LBPC1	Laboratory, Point of Care	4	US	GLG	AT2	9'-0"	3'-0"	30-45	60	300	.		LS	.								-	6	2	R	R	Y	13	.	Y	.			
LBRB1	Laboratory, Research Biochemistry	4	US	GLG	AT2	9'-0"	3'-0"	30-45	100	500	.		LS	E	.	1	.	1	.	.	.	B			-	6	2	R	R	Y	13	.	Y	M
LBRC1	Laboratory, Research Clean	4	US	GLG	AT2	9'-0"	3'-0"	30-45	100	500	.		LS	E	.	1	.	1	.	.	.	B			-	6	2	R	R	Y	13	.		M
LBRC2	Laboratory, Research Containment	4	US	GLG	AT2	9'-0"	3'-0"	30-45	60	500	.		LS	E	.	1	.	1	.	.	.	B			-	6	2	R	R	Y	13	.	Y	M
LBRI1	Laboratory, Radioimmunoassay	4	US	GLG	AT2	9'-0"	3'-0"	30-45	100	500	.		LS	E	.	1	.	1	.	.	.	B			-	6	2	R	R	Y	13	.		
LBPR1	Laboratory, Radiation Protection	4	US	GLG	AT2	9'-0"	3'-0"	30-45	100	500	.											-	6	2	R	R	Y	13	.					



Room Code	ROOM FUNCTION	C/O	ARCHITECTURAL				STRUCTURAL		ELECTRICAL			MEDICAL GAS AND VACUUM					MECHANICAL																
			ER	GL	GLG	10'-0 J	NC	30-40	60	2100 D,J	RA	LB	7	D	L	P	M	S	O	D	N	I	G	W	A	BL	AC	OA	SM	WNRH	IN	FN	EX
LDDR1	Operating Room, Labor and Delivery, C Section	1	ER	GLG	GLG	10'-0 J	30-40	60	2100 D,J	RA	LB	7			13		5	2	2	2	C,D	++	20	4	R	R	S	14	14				C,O,P
LDEP1	Labor and Delivery, Exam and Preparation	3	US	GLG	AT2	8'-0	4'-0	30-40	60	500		R	L		1		1		1			B	O	6	2	75	75	Y	14				
L DPR1	Labor and Delivery, Infant Preparation Room	4	UT	GLG	AT1	8'-0	3'-0	30-40	100	300													-	10	2	*	68	Y	13		Y		
LDRP1	Labor and Delivery, LDR / LDRP	1	US	GLG	AT2	9'-0	4'-0	30-40	60	300 D,F	2100	RA	LB		2		2		2			E	O	6	2	75	75	Y	14			P	
LDRP3	Labor and Delivery, LDR / LDRP, Airborne Infection Isolation	1	US	GLG	AT2	9'-0	4'-0	30-40	60	300 D,F	2100	RA	LB		2		2		2			E	--	12	2	75	75	Y	14		Y	E,P,Q	
LIBB1	Library, Book / Periodical, Stacks	N	CP	GAF	AT1	10'-0 L	20-30	D	300													O	a	a	*	68	Y	13					
LIBD1	Library, Reference Desk	N	CP	GAF	AT1	10'-0	3'-0	20-30	100	500													O	a	a	*	68	Y	13				
LIBV1	Library, Education / Resource	N	CP	GAF	AT1	10'-0	3'-0	20-30	150	500													O	a	a	*	68	Y	13				
LIBW1	Library, Staff Workroom	N	CP	GPT	AT1	9'-0	3'-0	20-30	100	500													O	a	a	*	68	Y	13				
LMAB1	Laboratory, Anaerobic Bacteria - TB	4	US	GLG	GLG	9'-0	3'-0	30-45	100	500		R	L			1	1					B	-	6	2	R	R	Y	13		Y	M	
LMBB1	Laboratory, Blood Bank, Small	4	US	GLG	AT2	9'-0	3'-6	30-45	100	500			LS	E									O	6	2	R	R	Y	13				
LMBB2	Laboratory, Blood Bank, Medium	4	US	GLG	AT2	9'-0	3'-6	30-45	C	500			LS	E									O	6	2	R	R	Y	13				
LMBB3	Laboratory, Blood Bank, Large	4	US	GLG	AT2	9'-0	3'-6	30-45	C	500			LS	E									O	6	2	R	R	Y	13				
LMCH2	Laboratory, Chemistry, Small	4	US	GLG	AT2	9'-0	G	30-45	100	500		R	L			1						B	-	6	2	R	R	Y	13		Y	M	
LMCH3	Laboratory, Chemistry, Medium	4	US	GLG	AT2	9'-0	G	30-45	100	500		R	L			1						B	-	6	2	R	R	Y	13		Y	M	
LMCH4	Laboratory, Chemistry, Large	4	US	GLG	AT2	9'-0	G	30-45	100	500		R	L			1						B	-	6	2	R	R	Y	13		Y	M	
LMCY1	Laboratory, Cytology, Small	4	US	GLG	AT2	9'-0	3'-0	30-45	100	500		R	L			1						B	-	6	2	R	R	Y	13		Y	M	
LMCY2	Laboratory, Cytology, Medium	4	US	GLG	AT2	9'-0	3'-0	30-45	100	500		R	L			1						B	-	6	2	R	R	Y	13		Y	M	
LMCY3	Laboratory, Cytology, Large	4	US	GLG	AT2	9'-0	3'-0	30-45	100	500		R	L			1						B	-	6	2	R	R	Y	13		Y	M	
LMHC1	Laboratory, Histopathology, Medium	4	US	GLG	AT2	9'-0	3'-0	30-45	100	500		R	L	E		1						B	-	6	2	R	R	Y	13		Y	M	
LMHC2	Laboratory, Histopathology, Large	4	US	GLG	AT2	9'-0	3'-0	30-45	100	500		R	L	E		1						B	-	6	2	R	R	Y	13		Y	M	
LMHI2	Laboratory, Hematology, Small	4	US	GLG	GLG	9'-0	3'-0	30-45	100	500		R	L	E		1						B	-	6	2	R	R	Y	13		Y	M	
LMHI3	Laboratory, Hematology, Medium	4	US	GLG	GLG	9'-0	3'-0	30-45	100	500		R	L	E		1						B	-	6	2	R	R	Y	13		Y	M	

Room Code	ROOM FUNCTION	C/O ID	ARCHITECTURAL				STRUCTURAL		ELECTRICAL			MEDICAL GAS AND VACUUM					MECHANICAL																					
			MATL & FIN			CLG	DR & NC	FLR	LD	L E	N	ES	PWR	M	D	L	P	M	S	O	D	N	I	G	W	A	N	BL	AC	OA	SM	WNR	H	IN	FN	EX	N	
			FL	WL	GLG																																	GLG
LMHI4	Laboratory, Hematology, Large	4	US	GLG	GLG	9'-0"	3'-0"	30-45	100	500	.	R	L	E	.	.	1	.	.	.	.	.	.	.	.	.	B	-	6	2	R	R	Y	13	.	Y	M	
LMHS1	Laboratory, Histology, Medium	4	US	GLG	GLG	9'-0"	3'-0"	30-45	100	500	.	R	L	E	.	.	1	.	.	.	.	.	.	.	.	.	B	-	6	2	R	R	Y	13	.	Y	M	
LMHS2	Laboratory, Histology, Large	4	US	GLG	GLG	9'-0"	3'-0"	30-45	100	500	.	R	L	E	.	.	1	.	.	.	.	.	.	.	.	.	B	-	6	2	R	R	Y	13	.	Y	M	
LMM02	Laboratory, Microbiology, Small	4	US	GLG	GLG	9'-0"	3'-0"	30-45	100	500	.	R	L	E	.	.	1	.	.	.	.	.	.	.	.	.	B	-	6	2	R	R	Y	13	.	Y	M	
LMM03	Laboratory, Microbiology, Medium	4	US	GLG	GLG	9'-0"	3'-0"	30-45	100	500	.	R	L	E	.	.	1	.	.	.	.	.	.	.	.	.	B	-	6	2	R	R	Y	13	.	Y	M	
LMM04	Laboratory, Microbiology, Large	4	US	GLG	GLG	9'-0"	3'-0"	30-45	100	500	.	R	L	E	.	.	1	.	1	.	.	.	.	.	.	.	B	-	6	2	R	R	Y	13	.	Y	M	
LMML1	Laboratory, Automated, Molecular, Diagnostic	4	US	GLG	GLG	9'-0"	3'-0"	30-45	100	500	.	R	L	E	.	.	1	.	1	.	.	.	.	.	.	.	B	-	6	2	R	R	Y	13	.	Y	M	
LMML2	Laboratory, Reagent Preparation, Amplification Room	4	US	GLG	GLG	9'-0"	3'-0"	30-45	100	500	.	R	L	E	.	.	1	.	1	.	.	.	.	.	.	.	B	-	6	2	R	R	Y	13	.	Y	M	
LMML3	Laboratory, Specimen Processing, Preamplification Room	4	US	GLG	GLG	9'-0"	3'-0"	30-45	100	500	.	R	L	E	.	.	1	.	1	.	.	.	.	.	.	.	B	-	6	2	R	R	Y	13	.	Y	M	
LMML4	Laboratory, Amplification / Instrument Room	4	US	GLG	GLG	9'-0"	3'-0"	30-45	100	500	.	R	L	E	.	.	1	.	1	.	.	.	.	.	.	.	B	-	6	2	R	R	Y	13	.	Y	M	
LMMP1	Laboratory Microbiology / Parasitology	4	US	GLG	GLG	9'-0"	3'-0"	30-45	100	500	.	R	L	.	.	.	1	.	.	.	.	.	.	.	.	.	B	-	6	2	R	R	Y	13	.	Y	M	
LMMY1	Laboratory Mycology	4	US	GLG	GLG	9'-0"	3'-0"	30-45	100	500	.	R	L	.	.	.	1	.	.	.	.	.	.	.	.	.	B	-	6	2	R	R	Y	13	.	Y	M	
LMS01	Laboratory, Serology, Small	4	US	GLG	GLG	9'-0"	3'-0"	30-45	100	500	.	R	L	.	.	.	1	.	.	.	.	.	.	.	.	.	B	-	6	2	R	R	Y	13	.	Y	M	
LMS02	Laboratory, Serology, Medium	4	US	GLG	GLG	9'-0"	3'-0"	30-45	100	500	.	R	L	.	.	.	1	.	.	.	.	.	.	.	.	.	B	-	6	2	R	R	Y	13	.	Y	M	
LMS03	Laboratory, Serology, Large	4	US	GLG	GLG	9'-0"	3'-0"	30-45	100	500	.	R	L	.	.	.	1	.	.	.	.	.	.	.	.	.	B	-	6	2	R	R	Y	13	.	Y	M	
LMT01	Laboratory, Toxicology	4	US	GLG	GLG	9'-0"	3'-0"	30-45	100	500	.	R	L	.	.	.	1	.	.	.	.	.	.	.	.	.	B	-	6	2	R	R	Y	13	.	Y	M	
LMU02	Laboratory, Urinalysis, Small	4	US	GLG	GLG	9'-0"	3'-0"	30-45	100	500	.	R	L	.	.	.	1	.	.	.	.	.	.	.	.	.	B	-	6	2	R	R	Y	13	.	Y	M	
LMU03	Laboratory, Urinalysis, Medium	4	US	GLG	GLG	9'-0"	3'-0"	30-45	100	500	.	R	L	.	.	.	1	.	.	.	.	.	.	.	.	.	B	-	6	2	R	R	Y	13	.	Y	M	
LMU04	Laboratory, Urinalysis, Large	4	US	GLG	GLG	9'-0"	3'-0"	30-45	100	500	.	R	L	.	.	.	1	.	.	.	.	.	.	.	.	.	B	-	6	2	R	R	Y	13	.	Y	M	
LMV01	Laboratory, Virology, Medium	4	US	GLG	GLG	9'-0"	3'-0"	30-45	100	500	.	R	L	.	.	.	1	.	.	.	.	.	.	.	.	.	B	-	6	2	R	R	Y	13	.	Y	M	
LMV02	Laboratory, Virology, Large	4	US	GLG	GLG	9'-0"	3'-0"	30-45	100	500	.	R	L	.	.	.	1	.	.	.	.	.	.	.	.	.	B	-	6	2	R	R	Y	13	.	Y	M	
LOB01	Lobby, Seating Area	N	SP	GPT	AT1	VAR	SP	35-45	100	150	.	.	.	.	.	.	.	.	.	.	.	.	.	.	.	.	.	O	a	a	*	68	Y	13	.	.	.	
LOB02	Lobby, Vestibule	N	SP	GPT	AT1	VAR	SP	35-45	100	150	.	.	.	.	.	.	.	.	.	.	.	.	.	.	.	.	.	.	+	a	a	*	68	Y	13	.	.	.



Room Code	ROOM FUNCTION	ARCHITECTURAL					STRUCTURAL		ELECTRICAL			MEDICAL GAS AND VACUUM					MECHANICAL																			
		C	M		F		CLG	DR &	NC	FLR	LIGHT	ES	PWR	M	D	L	P	S	O	D	N	I	G	W	A	BLAC	OA	SM	WNRH	IN	FN	EX	N			
ID		E	FL	WL	CLG	HT	SIZE	STC	LD	LEV	N	PW	LT	N	A	A	A	V	V	E	E	O	O	A	D	N										
LOB03	Lobby, Main	N	SP	GPT	AT1	VAR	SP	35-45	100	150	.	.	.	.	.	.	.	.	.	.	.	.	.	.	.	O	a	a	*	68	Y	13	.	.		
LOB05	Lobby, Vestibule, Ambulance Entrance	N	SP	GPT	AT1	VAR	SP	.	100	150	.	.	.	.	.	.	.	.	.	.	.	.	.	.	.	+	a	a	*	68	Y	13	.	.		
LR001	Lockers, Personal Property	N	US	GLG	GLG	8'-0	SP	30-45	100	200	.	.	.	.	.	.	.	.	.	.	.	.	.	.	.	O	4	1	*	68	Y	13	.	.		
LR002	Lockers, Changing	N	CT	GLG	GLG	8'-0	3'-0	30-45	100	200	.	.	.	.	.	.	.	.	.	.	.	.	.	.	.	-	10	2	*	68	Y	13	.	.		
MAGV1	Medical Material AGV Charging Station	4	UT	GPT	AT1	10'-0	E	30-45	C	50	.	.	.	.	.	.	.	.	.	.	.	.	.	.	.	O	4	1	*	68	Y	13	.	.		
MAGV2	Medical Material AGV Dispatch	4	UT	GPT	AT1	10'-0	E	30-45	C	500	.	.	.	.	.	.	.	.	.	.	.	.	.	.	.	O	4	1	*	68	Y	13	.	.		
MAGV3	Medical Material AGV Repair	4	UT	GPT	AT1	10'-0	E	30-45	C	500	.	.	.	.	.	.	.	.	.	.	.	.	.	.	.	O	4	1	*	68	Y	13	.	.		
MECH1	Mechanical Rooms / Electrical Rooms	N	CS	SSP	EXP	C	VAR	40-70	B	300	.	R	LS	S	.	.	.	.	.	.	.	.	.	.	.	.	a	a	.	50	Y	13	.	.	K	
MECH2	Air Handling Rooms	N	CS	SSP	EXP	C	VAR	40-70	B	300	.	R	LS	S	.	.	.	.	.	.	.	.	.	.	.	.	.	a	a	.	50	Y	13	.	.	K
MEDP1	Medication Room	4	UT	GPT	AT1	8'-0	3'-0	30-40	100	1100	.	R	L	.	.	.	.	.	.	.	.	.	.	.	.	+	4	2	*	70	Y	13	.	.		
MMCR1	Medical Material, Cart Receiving	4	UT	GPT	AT1	10'-0	E	30-45	100	50	.	.	.	.	.	.	.	.	.	.	.	.	.	.	.	O	4	1	*	68	Y	13	.	.		
MMCR2	Medical Material, Cart Restocking	4	UT	GPT	AT1	10'-0	E	30-45	100	50	.	.	.	.	.	.	.	.	.	.	.	.	.	.	.	O	4	1	*	68	Y	13	.	.		
MMGS1	Medical Material, General Storage	4	UT	GPT	AT1	10'-0	4'-0	30-45	125	100	.	.	.	.	.	.	.	.	.	.	.	.	.	.	.	O	4	1	*	68	Y	13	.	.		
MMRP1	Medical Material, Receiving / Process	4	UT	GPT	AT1	10'-0	4'-0	30-45	100	200	.	.	.	.	.	.	.	.	.	.	.	.	.	.	.	O	4	1	75	55	Y	13	.	.		
MRMB1	Mail Room, Distribution Area	N	UT	GPT	AT1	9'-0	3'-0	30-40	100	500	.	.	.	.	.	.	.	.	.	.	.	.	.	.	.	O	4	1	*	68	Y	13	.	.		
MRPS1	Mail Room, U.S. Post Office	N	UT	GPT	AT1	9'-0	3'-0	30-40	100	500	.	.	.	.	.	.	.	.	.	.	.	.	.	.	.	-	4	1	*	68	Y	13	.	Y	U	
MRRS1	Mail Room, Receiving / Sorting	N	UT	GPT	AT1	9'-0	B	30-40	125	500	.	.	.	.	.	.	.	.	.	.	.	.	.	.	.	O	4	1	*	68	Y	13	.	.		
MRS01	Med Records, Storage, Fixed	4	UT	GPT	AT1	9'-0	3'-0	30-40	150	300	.	.	.	.	.	.	.	.	.	.	.	.	.	.	.	O	4	1	*	68	Y	13	.	.		
MRS02	Med Records, Storage, Movable	4	UT	GPT	AT1	9'-0	3'-0	30-40	D	300	.	.	.	.	.	.	.	.	.	.	.	.	.	.	.	O	4	1	*	68	Y	13	.	.		
MRWK1	Med Records, Workroom	4	CP	GPT	AT1	8'-0	3'-0	30-40	100	700	.	.	.	.	.	.	.	.	.	.	.	.	.	.	.	O	4	1	*	68	Y	13	.	.		
NBCD1	NBC Decontamination Suite	3	CS	SSP	SSP	VAR	VAR	30-40	100	500	.	R	L	.	1	.	.	1	.	.	1	.	1	.	B	-	12	2	*	68	Y	14	.	Y	M	
NBCD2	Decontamination Shower	3	CT	SSP	SSP	VAR	VAR	30-40	60	300	.	.	.	.	.	.	.	.	.	.	.	.	.	.	.	-	12	2	*	68	Y	14	.	Y	M	
NBCD3	Decontamination, Anteroom	4	US	SSP	SSP	VAR	VAR	30-40	100	300	.	.	LS	.	.	.	.	.	.	.	.	.	.	.	.	-	12	2	*	68	Y	14	.	Y	M	

Room Code	ROOM FUNCTION	C O D E	ARCHITECTURAL				STRUCTURAL		ELECTRICAL				MEDICAL GAS AND VACUUM						MECHANICAL																			
			M A T L & F I N			NC CLG DR & S I Z E S T C	FLR L D	L I G H T L E V E L	E S P W R P W L T N	M D L P M S O D N	W A I V E E O O A D N	I G N	B L A C	T E M P																								
			FL	WL	CLG									DR	FLR	LIGHT	ES	PWR	M	D	L	P	M	S	O	D	N	I	G	N	BL	OA	SM	WNR	H	I	N	FN
NBCD4	Decontamination, Patient Preparation	3	CS	SSP	SSP	VAR	VAR	30-40	100	500	.	R	L	.	.	.	.	.	.	.	.	.	.	.	.	.	-	12	2	*	68	Y	14	.	Y	M		
NBCD5	Decontamination, Patient Transition	3	CS	SSP	SSP	VAR	VAR	30-40	100	500	.	R	L	.	.	.	.	.	.	.	.	.	.	.	.	.	-	12	2	*	68	Y	14	.	Y	M		
NCWD1	Nourishment Center	4	UT	GLG	AT2	8'-0	3'-0	30-40	100	500	.	.	.	U	.	.	.	.	.	.	.	.	.	.	.	.	O	6	2	*	68	Y	14	.	.	.		
NCWD5	Demonstration Kitchen	N	US	GPT	AT1	8'-6	3'-0	25-35	60	700	A	.	.	.	.	.	.	.	.	.	.	.	.	.	.	O	a	a	*	70	Y	13	.	Y	M			
NMBP1	Nuclear Medicine, Blood Product Compounding	4	US	LLG	AT2	8'-0	3'-0	30-40	100	500	.	.	.	LS	.	.	.	.	.	.	.	.	.	.	.	r	r	2	*	68	Y	r	r	Y	M,W			
NMCR1	Nuclear Medicine, Computer Room	4	US	GPT	AT1	8'-0	3'-0	30-40	100	500	.	.	.	LS	.	.	.	.	.	.	.	.	.	.	.	O	6	2	*	68	Y	13	.	.	.			
NMDC1	Nuclear Medicine, Dose Calibration	4	US	LLG	AT1	8'-0	3'-0	30-40	60	500	.	.	.	LS	.	1	.	.	1	.	.	1	.	.	.	-	6	2	*	68	Y	14	.	Y	M			
NMDS1	Nuclear Medicine, Decay Storage	4	US	LLG	AT1	8'-0	3'-0	30-40	60	300	.	.	.	LS	E	.	.	.	.	.	.	.	.	.	.	-	6	2	*	68	Y	14	.	Y	.			
NMGS1	Nuclear Medicine, General Scanning	3	US	GLG	AT1	10'-0	4'-0	30-40	100	500	A	.	.	LS	.	.	.	1	.	.	1	.	.	.	O	6	2	*	68	Y	13	.	.	.				
NMIR1	Nuclear Medicine, Injection Room	3	US	LLG	AT1	8'-0	4'-0	30-40	60	700	A	.	.	LS	.	1	.	.	1	.	.	1	.	.	-	6	2	*	68	Y	14	.	Y	.				
NMLA1	Nuclear Medicine, Anteroom, Radiopharmacy	4	US	GLG	AT1	8'-0	3'-0	30-40	100	500	.	.	.	LS	.	.	.	.	.	.	.	.	.	.	.	-	6	2	*	68	Y	14	.	Y	M			
NMPC1	Nuclear Medicine, Radiopharmacy, Non-Sterile Compounding	4	US	LLG	AT1	8'-0	3'-0	30-40	100	500	.	.	.	LS	.	.	.	.	.	.	.	.	.	.	.	-	6	2	*	68	Y	14	.	Y	M			
NMRP1	Nuclear Medicine, Radiopharmacy	C	US	LLG	AT2	8'-0	3'-0	30-40	100	500	.	.	.	LS	.	.	.	.	.	.	.	.	.	.	.	-	6	2	*	68	Y	13	.	Y	M			
NMSS1	Nuclear Medicine, Special Scanning	3	US	GLG	AT1	8'-0	4'-0	30-40	100	500	A	.	.	LS	E	1	.	.	1	.	.	1	.	.	-	6	2	*	68	Y	14	.	Y	.				
NMUR1	Nuclear Medicine, Uptake Room	3	US	GLG	AT1	8'-0	3'-0	30-40	100	200	.	.	.	LS	E	1	.	.	1	.	.	1	.	.	-	6	2	*	68	Y	13	.	Y	.				
NMVC1	Nuclear Medicine, Vestibule, Radiopharmacy	4	US	GLG	AT1	8'-0	3'-0	30-40	100	500	.	.	.	LS	.	.	.	.	.	.	.	.	.	.	.	-	6	2	*	68	Y	14	.	Y	M			
NMWB1	Nuclear Medicine, Whole Body	3	US	GLG	AT1	10'-0	4'-0	30-40	100	500	.	.	.	LS	E	1	.	.	1	.	.	1	.	.	-	6	2	*	68	Y	14	.	Y	.				
NMWR1	Nuclear Medicine, Waiting Room Hot	4	US	LPT	AT1	8'-0	4'-0	30-40	60	300	.	.	.	.	.	.	.	.	.	.	.	.	.	.	-	6	1	*	68	Y	14	.	Y	.				
NSTA1	Nurse Station	4	UT	GPT	AT1	8'-0	M	30-40	100	300	.	R	L	.	.	.	.	.	.	.	.	.	.	.	O	6	2	*	68	Y	14	.	.	.				
NSTA3	Nurse Station, Substation	4	UT	GPT	AT1	8'-0	M	30-40	100	300	.	R	L	.	.	.	.	.	.	.	.	.	.	.	O	6	2	*	68	Y	14	.	.	.				
NSTA4	Nurse Station, Outpatient	4	UT	GPT	AT1	9'-0	M	35-45	60	300	.	.	.	.	.	.	.	.	.	.	.	.	.	.	O	a	a	*	70	Y	14	.	.	.				
NSTA5	Nurse Station, Control, Operating Room	4	ER	GLG	GLG	9'-0	M	30-45	100	300	.	R	L	.	.	.	.	.	.	.	.	.	.	.	O	6	2	75	75	Y	14	.	.	.				
NT001	Pneumatic Tube Station		Space Parameter Notes: a																																			

Room Code	ROOM FUNCTION	C O I D	ARCHITECTURAL	STRUCTURAL	ELECTRICAL	MEDICAL GAS AND VACUUM	MECHANICAL		
			CON MATL & FIN	NC CLG DR & SIZES	FLR LD	LIGHT LEV N	ES PWR PW LT N	D L W A S O D N I G	TEMP
			E FL WL CLG HT	STC				M D L P M S O D N I G	BLAC OA SM WNRH IN FN EX N
NYAF1	Nursery, Anteroom, Feeding Preparation	4	US GLGAT2 8'-0"	3'-0 30-40 STC 40	60	500	. LS .	. . . . .	+ 6 2 * 68 Y 14 . .
NYAR1	Nursery, Anteroom with Scrub Sink	4	US GLGAT2 8'-0"	4'-0 25-35 STC 45	60	300	. . . . .	. . . . .	+ 12 3 74 80 Y 14 . . P
NYEC1	Nursery, Extracorporeal Membrane Oxygenation (ECMO) Room	2	US GLGAT2 9'-0"	4'-0 25-35 STC 50	60	500	. R L .	3 . . . 3 . . . 3 . . . G	++ 6 2 74 80 T 14 14 . P
NYFA1	Nursery, Feeding Area	3	US GLGAT2 9'-0"	4'-0 25-35 STC 45	60	500	A . LS .	. . . . 1 . . . 1 . . . .	O 6 1.5 74 80 Y 14 . P
NYFP1	Nursery, Infant Feeding Preparation Room	4	US GLGAT2 8'-0"	3'-0 30-40 STC 40	60	500	. LS .	. . . . .	r r 2 * 68 Y r r r M,R
NYFS1	Nursery, Storage, Breast Milk / Formula	4	US GLGAT2 8'-0"	3'-0 30-40 STC 40	60	500	. LS .	. . . . .	+ 6 2 * 68 Y 14 . .
NYIC1	Nursery, Level II	2	US GLGAT2 9'-0"	4'-0 25-35 STC 50	60	700	A R L .	2 . . . 2 . . . 2 . . . G	++ 6 2 74 80 T 14 . P
NYIC2	Nursery, Level III	1	US GLGAT2 9'-0"	4'-0 25-35 STC 50	60	700	A RC L .	3 . . . 3 . . . 3 . . . G	++ 12 4 74 80 T 14 . O,P
NYIR1	Nursery, Isolation	2	US GLGAT2 9'-0"	4'-0 25-35 STC 50	60	700	A R L .	3 . . . 3 . . . 3 . . . A	-- 12 2 74 80 T 14 . Y A,P,Q
NYNN1	Nursery, Level I	3	US GLGAT2 9'-0"	4'-0 25-35 STC 50	60	700	A R L .	1 . . . 1 . . . 1 . . . H	++ 6 2 74 80 T 14 . P
NYPR1	Nursery, Procedure	2	US GLGAT2 9'-0"	4'-0 25-35 STC 50	60	500	. R L .	1 . . . 1 . . . 1 . . . G	++ 6 2 74 80 T 14 14 . P
NYPT1	Nursery, Parent Education	4	CP GPTAT1 8'-0"	4'-0 25-35 STC 45	60	700	A . . . .	. . . . .	O 6 2 74 80 T 13 . P
NYTU1	Nursery, Storage, Transport Unit	4	UT GPTAT1 8'-0"	L 35-45 STC 45	60	500	. R L .	. . . . .	O 4 1 * 68 Y 14 . .
NYUN1	Bedroom, NICU, Single Birth	1	US GLGAT2 9'-0"	4'-0 25-35 STC 50	60	700	A,D RC L .	3 . . . 3 . . . 3 . . . G	++ 12 4 74 80 T 14 . O,P
NYUN2	Bedroom, NICU, Multiple Births	1	US GLGAT2 9'-0"	4'-0 25-35 STC 50	60	700	A,D RC L .	3 . . . 3 . . . 3 . . . G	++ 12 4 74 80 T 14 . O,P
OFA03	Cubicle, Administrative	N	CP GPTAT1 8'-0"	3'-0 30-40 STC 40	60	300	. . . . .	. . . . .	O a a * 68 Y 13 . .
OFA04	Office, Administrative, Private	N	CP GPTAT1 8'-0"	3'-0 30-40 STC 40	60	300	. . . . .	. . . . .	O a a * 68 Y 13 . .
OFA05	Office, Administrative, Shared, 2-Person	N	CP GPTAT1 8'-0"	3'-0 30-40 STC 40	60	300	. . . . .	. . . . .	O a a * 68 Y 13 . .
OFC01	Office, Commander	N	CP GPTAT1 8'-0"	3'-0 30-40 STC 40	60	300	. . . . .	. . . . .	O a a * 68 Y 13 . .
OFD01	Office, Provider, Private	3	UT GPTAT1 8'-0"	3'-0 30-40 STC 50*	60	300	. . . . .	. . . . .	O 6 2 * 68 Y 14 . .
OFD02	Office, Provider, Shared	3	UT GPTAT1 8'-0"	3'-0 30-40 STC 50*	60	300	. . . . .	. . . . .	O 6 2 * 68 Y 14 . .
OFDC1	Office, Provider, Behavioral Health	N	CP GPTAT1 8'-0"	3'-0 30-40 STC 50*	60	300	. . . . .	. . . . .	O a a * 68 Y 14 . .
OFDC2	Office, Consultation	N	CP GPTAT1 8'-0"	3'-0 30-40 STC 50*	60	300	. . . . .	. . . . .	O a a * 68 Y 14 . .



Room Code	ROOM FUNCTION	C/O	ARCHITECTURAL				STRUCTURAL		ELECTRICAL			MEDICAL GAS AND VACUUM						MECHANICAL																					
			MATL & FIN		NC		FLR	LD	LIGHT	ES	PWR	M	D	L	P	S	O	D	N	I	G	W	A	BL	AC	OA	SM	WNR	RH	IN	FN	EX	N						
			FL	WL	CLG	DR & HT																												SIZE	STC	LEV	N	LT	N
OPMH4	Secured Observation	3	SV	GPT	GPT	8'-0"	3'-0"	30-40	60	500	A														O	6	2	*	68	Y	14								
OPMP1	Outpatient, Group Therapy, Speech / Language	3	CP	GPT	AT1	VAR	3'-0"	30-40	60	500															O	6	2	*	68	Y	13								
OPNR1	Nephrology Renal Study	3	US	GLG	AT2	8'-0"	3'-0"	30-40	60	500															1														
OPPE1	Echocardiograph	3	UT	GPT	AT1	8'-0"	3'-6"	30-40	60	500	A														O	6	2	*	70	Y	14								
OPPE2	Echocardiograph, Stress	3	UT	GPT	AT1	8'-0"	3'-6"	30-40	60	500															O	6	2	*	70	Y	14								
OPPF1	Pulmonary Function, Screening	3	UT	GPT	AT1	9'-0"	3'-6"	30-40	60	500															O	6	2	*	70	Y	14								
OPPF2	Pulmonary Function, Analysis	3	UT	GPT	AT1	9'-0"	3'-6"	30-40	60	500															1														
OPPF4	Pulmonary Function, Whole Body Analysis	3	UT	GPT	AT1	9'-0"	3'-6"	30-40	60	500															1														
OPPF5	Pulmonary Function, Treadmill	3	UT	GPT	AT1	9'-0"	3'-6"	30-40	60	500															1														
OPPF6	Pulmonary Function, Sleep Study	3	CP	GPT	AT1	8'-6"	3'-6"	30-40	60	100	A														1														
OPPF7	Pulmonary Function, Sleep Study, Monitoring	4	CP	GPT	AT1	8'-6"	3'-0"	30-40	60	300	A														O	6	2	*	70	Y	13								
OPPM1	Pacemaker Workroom	3	UT	GPT	AT1	8'-0"	3'-0"	30-40	60	1100															O	6	2	*	70	Y	14								
OPRC1	Respiratory, Equipment, Clean	N	UT	GLG	AT1	8'-0"	3'-6"	30-40	60	1100															1														
OPRS1	Respiratory, Equipment, Soiled	N	UT	GLG	AT1	8'-0"	3'-6"	30-40	60	1100															1														
OPRT1	Respiratory, Treatment, Multi-Station	3	UT	GLG	AT1	8'-0"	4'-0"	35-45	60	500															1														
OPTM1	Stress Testing, Treadmill	3	UT	GPT	AT1	9'-0"	3'-6"	30-40	60	500															1														
OPTM2	Cardiac, Tilt Table	3	UT	GPT	AT1	9'-0"	3'-6"	30-40	60	500															O	6	2	*	70	Y	14								
OPTM3	Outpatient, Treadmill, Underwater Chamber	3	CT	GPT	AT1	9'-0"	3'-6"	35-45	C	500															-	6	2	*	70	Y	13		Y						
OPVL1	Laboratory, Vascular	3	US	GLG	AT1	8'-0"	3'-6"	30-45	60	500															1														
ORCC1	Operating Room, Clean Core	4	PS	GLG	GLG	9'-0"	3'-6"	30-45	125	500																													
ORCM1	Operating Room, Storage, Cardiac	4	UT	GPT	AT1	9'-0"	3'-0"	30-45	60	500																													
ORCS1	Operating Room, Cystoscopic	1	PS	LLG	GLG	10'-0"	K	30-45	60	2100	D,J														6										8	2	4	2	C
ORCT1	Operating Room, Cardiothoracic	1	PS	GLG	GLG	10'-0"	K	30-45	60	2100	D,J																												

Room Code	ROOM FUNCTION	C/O	ARCHITECTURAL				STRUCTURAL		ELECTRICAL			MEDICAL GAS AND VACUUM						MECHANICAL																
			MATL & FIN			CLG DR & NC	FLR	LD	LEV N	ES PWR	PW LT N	M D L P M S O D N I G	A A A A V V E E O O A D N	W A	TEMP																			
			IE	FL	WL										CLG HT	SIZE	STC	LD	LEV N	ES PWR	PW LT N	M D L P M S O D N I G	A A A A V V E E O O A D N	W A	BLAC	OA	SM	WNRH	IN	FN	EX	N		
ORCW1	Operating Room, Workroom, Clean	4	PS	GLG	GLG	9'-0	3'-6	30-45	60	1100	D	R	L	.	1	.	.	1	.	.	1	.	.	I	+ 6	2	68	68	Y	14	.	.	.	
ORDA1	Operating Room, Decontamination	4	PS	GLG	GLG	9'-0	3'-6	30-45	60	300	.	R	L	.	1	.	.	1	.	.	1	.	.	.	- 6	2	*	68	Y	14	.	Y	M	
OREC1	Operating Room, Equipment Cleanup	4	UT	GLG	GLG	9'-0	3'-0	30-45	60	300	.	R	L	.	1	.	.	1	.	.	1	.	.	.	+ 6	2	75	68	Y	14	.	Y	.	
ORGE1	Operating Room, General, Equipment Storage	4	US	GLG	GLG	9'-0	4'-0	30-45	125	200	.	.	LS	.	.	.	.	.	.	.	.	.	.	.	+ 6	1.5	75	68	Y	14	.	.	.	
ORGS1	Operating Room, Integrated	1	PS	GLG	GLG	10'-0	K	30-45	60	2100	D,J	RA	LB	.	6	.	.	12	.	.	8	2	4	2	C	++ 20	4	R	R	S	14	17	.	C
ORHC1	Operating Room, Hybrid, Control	4	PS	GLG	GLG	9'-0	SP	30-45	60	500	A	RA	LS	.	.	.	.	.	.	.	.	.	.	.	+ 6	2	R	R	Y	14	.	.	N	
ORHE1	Operating Room, Hybrid, Equipment Storage	4	US	GLG	GLG	9'-0	4'-0	30-45	125	200	.	.	LS	.	.	.	.	.	.	.	.	.	.	.	+ 6	1.5	75	68	Y	14	.	.	.	
ORHL1	Operating Room, Equipment, Heart Lung Pump	4	UT	GLG	GLG	10'-0	K	30-45	60	200	.	.	LS	.	.	.	.	.	.	.	.	.	.	.	+ 6	2	R	R	Y	14	.	.	.	
ORHY1	Operating Room, Hybrid	1	PS	LLG	GLG	10'-0	K	30-45	60	2100	D,J	RA	LB	.	6	.	.	12	.	.	8	2	4	2	C	++ 20	4	R	R	S	14	17	.	C,N
ORNE1	Operating Room, Equipment, Neurology	4	UT	GLG	GLG	10'-0	4'-0	30-45	125	200	.	.	LS	.	.	.	.	.	.	.	.	.	.	.	+ 6	1.5	75	75	Y	14	.	.	.	
ORNS1	Operating Room, Neurology	1	PS	GCT	GLG	10'-0	K	30-45	60	2100	D,J	RA	LB	.	6	.	.	12	.	.	8	2	4	2	C	++ 20	4	R	R	S	14	17	.	C
OROE1	Operating Room, Equipment, Orthopaedic	4	UT	GLG	GLG	10'-0	4'-0	30-45	125	200	.	.	LS	.	.	.	.	.	.	.	.	.	.	.	+ 6	1.5	75	68	Y	14	.	.	.	
OROS1	Operating Room, Orthopaedic	1	PS	GLG	GLG	10'-0	K	30-45	60	2100	D,J	RA	LB	.	6	.	.	12	.	.	8	2	4	2	C	++ 20	4	R	R	S	14	17	.	C
ORPC1	Operating Room, Storage, Plaster Cart	4	US	GLG	GLG	9'-0	3'-6	30-45	60	50	.	.	LB	.	.	.	.	.	.	.	.	.	.	.	O 4	1	75	68	Y	14	.	.	.	
ORPH2	Operating Room, Workstation, Preparation / Hold	4	UT	GLG	GLG	9'-0	L	30-45	60	300	.	R	L	.	.	.	.	.	.	.	.	.	.	.	O 6	2	75	75	Y	14	.	.	.	
ORPP1	Operating Room, Patient Preparation / Induction	3	UT	GLG	GLG	9'-0	4'-0	30-45	60	500	.	R	L	.	1	.	.	1	.	.	1	.	.	B	O 6	2	75	75	Y	14	.	.	.	
ORPP2	Operating Room, Patient Preparation / Induction, Multi-Station	2	UT	GLG	GLG	9'-0	P	30-45	60	500	D	R	L	.	1	.	.	1	.	.	1	.	.	B	O 6	2	75	75	Y	14	.	.	.	
ORSA1	Operating Room, Scrub Sink	4	PS	GLG	GLG	9'-0	L	30-45	60	1100	.	.	L	.	.	.	.	.	.	.	.	.	.	.	+ 6	2	75	75	Y	14	.	.	.	
ORSR1	Operating Room, Sterile Processing	4	PS	GLG	GLG	9'-0	3'-6	30-45	60	500	.	.	L	.	.	.	.	.	.	.	.	.	.	.	- 10	2	75	75	Y	14	.	Y	.	
ORSS1	Operating Room, Storage, Sterile	4	PS	GLG	GLG	9'-0	4'-0	30-40	125	200	.	.	LS	.	.	.	.	.	.	.	.	.	.	.	+ 6	2	75	75	Y	14	.	.	.	
OTDL1	Occupational Therapy, Daily Living Skills	3	SP	GPT	AT1	9'-0	3'-6	30-40	60	500	.	.	.	.	.	.	.	.	.	.	.	.	.	.	O 6	2	*	68	Y	13	.	.	.	
OTEV1	Occupational Therapy, Exam	3	UT	GPT	AT1	8'-0	3'-6	30-40	60	500	.	.	.	.	.	.	.	.	.	.	.	.	.	.	O 6	2	*	68	Y	13	.	.	.	
OTGC1	Occupational Therapy, General Clinic Area	3	UT	GPT	AT1	9'-0	3'-6	30-40	60	500	.	.	.	.	.	.	.	.	.	.	.	.	.	.	O 6	2	*	68	Y	13	.	.	.	

Room Code	ROOM FUNCTION	C/O	ARCHITECTURAL				STRUCTURAL		ELECTRICAL			MEDICAL GAS AND VACUUM					MECHANICAL																						
			MATL & FIN		NC		FLR	LD	L I G H T	E S P W R	P W	L T	N	M	D	L	P	M	S	O	D	N	I	G	W	A	D	N	TEMP										
			FL	WL	CLG	DR & S I Z E																							STC	LD	LEV	N	A	A	A	V	V	E	E
OTNR1	Occupational Therapy, Neuro-Rehab Training	3	CP	GPT	AT1	10'-0	3'-6	30-40	60	500	.	.	.	.	.	.	.	.	.	.	.	.	.	.	.	.	.	O	6	2	*	68	Y	13	.	.	.	.	
OTWT1	Occupational Therapy, Simulation Laboratory	3	SP	GPT	AT1	8'-0	3'-6	30-40	60	500	A	.	.	.	.	.	.	.	.	.	.	.	.	.	.	.	.	O	6	2	*	68	Y	13	.	.	.	.	
PAIA1	Patient Admin Interview Area	4	CP	GPT	AT1	8'-0	3'-0	30-40	60	500	.	.	.	.	.	.	.	.	.	.	.	.	.	.	.	.	.	O	4	1	*	68	Y	13	.	.	.	.	
PEHS1	Hearing / Screening, Booth, 1-Person	3	CP	GAF	AT1	9'-0	3'-0	30-40	60	500	.	.	.	.	.	.	.	.	.	.	.	.	.	.	.	.	.	O	6	2	*	68	Y	13	.	.	.	.	
PEHS2	Hearing / Screening, Booth, Multi-Person	3	CP	GAF	AT1	9'-0	3'-0	30-40	60	500	.	.	.	.	.	.	.	.	.	.	.	.	.	.	.	.	.	O	6	2	*	68	Y	13	.	.	.	.	
PEHS3	Hearing / Diagnostic, Booth, 1-Person	3	CP	GAF	AT1	9'-0	3'-0	30-40	60	500	.	.	.	.	.	.	.	.	.	.	.	.	.	.	.	.	.	O	6	2	*	68	Y	13	.	.	.	.	
PEVH2	Vision / Hearing, Pediatric	3	UT	GPT	AT1	8'-0	3'-0	30-40	60	500	.	.	.	.	.	.	.	.	.	.	.	.	.	.	.	.	.	O	6	2	*	68	Y	13	.	.	.	.	
PHBS1	Pharmacy, Storage, Bulk, Low Volume	4	UT	GPT	AT1	VAR	3'-6	30-40	100	500	.	.	.	.	.	.	.	.	.	.	.	.	.	.	.	.	.	U	.	.	.	.	.	.	.	.	.	.	
PHBS2	Pharmacy, Storage, Bulk, Medium Volume	4	SV	GPT	AT1	VAR	3'-6	30-40	100	500	.	.	.	.	.	.	.	.	.	.	.	.	.	.	.	.	.	U	.	.	.	.	.	.	.	.	.	.	
PHBS3	Pharmacy, Storage, Bulk, High Volume	4	SV	GPT	AT1	VAR	3'-6	30-40	100	500	.	.	.	.	.	.	.	.	.	.	.	.	.	.	.	.	.	U	.	.	.	.	.	.	.	.	.	.	
PHC01	Pharmacy, Clean Room, Chemotherapeutics Compounding	4	US	GLG	AT2	9'-0	3'-0	30-40	60	1100	.	R	L	.	.	.	.	.	.	.	.	.	.	.	.	.	.	r	r	2	*	68	Y	r	r	r	r	M,R	
PHDS1	Pharmacy, Off Site Satellite, Medium Volume	4	UT	GPT	AT1	VAR	3'-6	30-40	60	1100	.	R	.	.	.	.	.	.	.	.	.	.	.	.	.	.	.	U	.	.	.	.	.	.	.	.	.	.	
PHDS2	Pharmacy, Off Site Satellite, High Volume	4	UT	GPT	AT1	VAR	3'-6	30-40	60	1100	.	R	.	.	.	.	.	.	.	.	.	.	.	.	.	.	.	U	.	.	.	.	.	.	.	.	.	.	
PHDS3	Pharmacy, On-Site, Satellite	4	UT	GPT	AT1	9'-0	3'-6	30-40	100	1100	.	R	L	.	.	.	.	.	.	.	.	.	.	.	.	.	.	U	.	.	.	.	.	.	.	.	.	.	
PHEV1	Pharmacy, Documentation Station, Receiving	4	UT	GPT	AT1	9'-0	3'-6	30-40	100	500	.	.	.	.	.	.	.	.	.	.	.	.	.	.	.	.	.	U	.	.	.	.	.	.	.	.	.	.	
PHIV1	Pharmacy, IV Admixture, Low Volume	4	US	GLG	AT2	9'-0	3'-0	30-40	60	1100	.	R	L	.	.	.	.	.	.	.	.	.	.	.	.	.	.	U	.	.	.	.	.	.	.	.	.	.	M,R
PHIV2	Pharmacy, IV Admixture, Medium Volume	4	US	GLG	AT2	9'-0	3'-0	30-40	60	1100	.	R	L	.	.	.	.	.	.	.	.	.	.	.	.	.	.	U	.	.	.	.	.	.	.	.	.	M,R	
PHIV3	Pharmacy, IV Admixture, High Volume	4	US	GLG	AT2	9'-0	3'-0	30-40	60	1100	.	R	L	.	.	.	.	.	.	.	.	.	.	.	.	.	.	U	.	.	.	.	.	.	.	.	.	M,R	
PHMP1	Pharmacy, Manufacturing and Prepack, Low Volume	4	UT	GPT	AT1	9'-0	3'-0	30-40	100	1100	.	R	L	.	.	.	.	.	.	.	.	.	.	.	.	.	.	U	.	.	.	.	.	.	.	.	.	.	
PHMP2	Pharmacy, Manufacturing and Prepack, Medium Volume	4	UT	GPT	AT1	9'-0	3'-0	30-40	100	1100	.	R	L	.	.	.	.	.	.	.	.	.	.	.	.	.	.	U	.	.	.	.	.	.	.	.	.	.	
PHMP3	Pharmacy, Manufacturing and Prepack, High Volume	4	UT	GPT	AT1	9'-0	3'-0	30-40	100	1100	.	R	L	.	.	.	.	.	.	.	.	.	.	.	.	.	.	U	.	.	.	.	.	.	.	.	.	.	
PHOD1	Pharmacy, Storage / Dispensing, Low Volume	4	UT	GPT	AT1	9'-0	3'-6	30-40	100	1100	.	R	L	.	.	.	.	.	.	.	.	.	.	.	.	.	.	U	.	.	.	.	.	.	.	.	.	.	
PHOD2	Pharmacy, Storage / Dispensing, Medium Volume	4	UT	GPT	AT1	9'-0	3'-6	30-40	100	1100	.	R	L	.	.	.	.	.	.	.	.	.	.	.	.	.	.	U	.	.	.	.	.	.	.	.	.	.	

Room Code	ROOM FUNCTION	C/O	ARCHITECTURAL				STRUCTURAL		ELECTRICAL		MEDICAL GAS AND VACUUM				MECHANICAL																													
			MATL & FIN	CLG	DR & NC	SIZE	FLR	LIGHT	ES PWR		M	D	L	P	S	O	D	N	I	G	W	A	TEMP	BLAC	OA	SM	WNRH	IN	FN	EX	N													
PHOD3	Pharmacy, Storage / Dispensing, High Volume	4	UT	GPT	AT1	9'-0"	3'-6"	30-40	100	1100	R	L																																
PHR01	Pharmacy, Prescription Assembly, Robotics / Automation	4	UT	GPT	AT1	9'-0"	N	30-40	100	1100			U																															
PHUD1	Pharmacy, Unit Dose	4	UT	GPT	AT1	9'-0"	3'-0"	30-40	60	1100	R	L																																
PHVS1	Pharmacy, Inpatient, Vestibule	4	UT	GPT	AT1	9'-0"	3'-0"	30-40	60	300																																		
PLAY1	Play Room	3	CP	GPT	AT1	9'-0"	3'-0"	35-45	60	300																																		
PMCC1	Plant Maintenance, Control Center	N	CS	GPT	AT1	9'-0"	VAR	30-40	100	500	R	LS	S																															
PMCF1	Plant Maintenance, CADD / File Room	N	CS	GPT	AT1	8'-0"	3'-0"	30-40	D	300																																		
PMCW1	Plant Maintenance, Common Area	N	CS	GPT	AT1	9'-0"	VAR	30-40	100	300				1																														
PMWSX	Plant Maintenance Workstation Areas	N	CS	GPT	AT1	9'-0"	VAR	30-40	100	300				1																														
PTAP1	Physical Therapy, Aquatic Pool, Small	Space Parameter Notes: b																																										
PTAP2	Physical Therapy, Aquatic Pool, Medium	Space Parameter Notes: b																																										
PTAP3	Physical Therapy, Aquatic Pool, Large	Space Parameter Notes: b																																										
PTAT1	Physical Therapy, Amputee Training	3	SP	GPT	AT1	D	3'-6"	30-40	60	500																																		
PTBT1	Physical Therapy, Back Treatment	3	UT	GPT	AT1	9'-0"	3'-6"	30-40	60	500																																		
PTCW1	Physical Therapy, Tech Workstation	4	UT	GPT	AT1	D	L	30-40	60	500																																		
PTEA1	Physical Therapy, Exercise Gym	3	US	GPT	AT1	D	4'-0"	35-45	60	300																																		
PTEM1	Physical Therapy, EMG (Electromyography)	3	UT	GPT	AT1	9'-0"	3'-6"	35-45	60	500																																		
PTES1	Physical Therapy, Exercise Stations	3	UT	GPT	AT1	D	L	35-45	60	300																																		
PTGL1	Physical Therapy, Gait Obs. Lane	3	UT	GPT	AT1	D	L	35-45	60	500																																		
PTIS1	Physical Therapy, Isokinetic Station, Diagnostic	3	UT	GPT	AT1	D	3'-6"	35-45	C	300																																		
PTPR1	Physical Therapy, Rehab, Private	3	UT	GPT	AT1	9'-0"	3'-6"	35-45	60	500																																		
PTTC1	Physical Therapy, Treatment, Cubicle	3	UT	GPT	AT1	D	P	35-45	60	500																																		
PTTS1	Physical Therapy, Treatment Support	3	UT	GPT	AT1	D	L	35-45	60	500																																		



Room Code	ROOM FUNCTION	C O I D E	ARCHITECTURAL				STRUCTURAL			ELECTRICAL					MEDICAL GAS AND VACUUM					MECHANICAL																	
			FL	WL	CLG	DR & CLG	HT	NC SIZE	STC	FLR LD	LIGHT LEV	N	ES PW	PWR LT	N	M A	D A	L V	P V	S E	O E	D O	N A	I O	G A	D D	N N	TEMP									
																												BL	OA	SM	WN	NR	HR	IN	FN	EX	N
PTWT1	Physical Therapy, Whirlpool	3	CT	GPT	AT1	9'-0	3'-6	35-45	60	500	.	.	.	.	.	.	.	.	.	.	.	.	.	.	.	.	-	6	2	*	70	Y	13	.	.	Y	.
RAA01	Chapel, Altar	N	CP	GPT	AT1	9'-0	L	20-30	60	300	A	.	.	.	.	.	.	.	.	.	.	.	.	.	.	.	.	.	.	.	.	.	.	.	.	.	.
RABS1	Chapel, Chancel	N	CP	GPT	AT1	9'-0	3'-0	20-30	60	300	A	.	.	.	.	.	.	.	.	.	.	.	.	.	.	.	.	.	.	.	.	.	.	.	.	.	.
RAMR1	Chapel, Meditation	N	CP	GPT	AT1	9'-0	3'-0	20-30	60	300	A	.	.	.	.	.	.	.	.	.	.	.	.	.	.	.	.	.	.	.	.	.	.	.	.	.	.
RAS01	Chapel, Seating	N	CP	GPT	AT1	VAR	L	20-30	60	150	A	.	.	.	.	.	.	.	.	.	.	.	.	.	.	.	.	.	.	.	.	.	.	.	.	.	.
RASR1	Chapel, Storage, Sacristy	N	CP	GPT	AT1	9'-0	3'-0	20-30	125	100	.	.	.	.	.	.	.	.	.	.	.	.	.	.	.	.	.	.	.	.	.	.	.	.	.	.	.
RCA01	Alcove, AED (Automatic External Defibrillator)	Space Parameter Notes: a and c																																			
RCA02	Alcove, Portable Patient Lift	Space Parameter Notes: a																																			
RCA04	Alcove, Warmer, Blanket / Fluid	Space Parameter Notes: a																																			
RDC01	Renal Dialysis, Airborne Infection Isolation	3	US	GLG	GLG	8'-6	4'-0	35-45	60	500	.	R	L	.	2	.	.	1	.	.	1	.	.	.	.	.	-	-	12	2	*	70	Y	14	.	Y	.
RDC02	Renal Dialysis, Multi-Station	3	US	GPT	AT1	8'-6	P	35-45	60	500	.	R	L	.	2	.	.	1	.	.	1	.	.	.	.	B	O	6	2	*	70	Y	14	.	.	.	.
RDP01	Renal Dialysis, Storage, Equipment Portable	N	US	GLG	AT2	8'-6	4'-0	35-45	60	500	.	R	.	.	.	.	.	.	.	.	.	.	.	.	.	.	O	6	2	*	70	Y	14	.	.	.	.
RDWT1	Renal Dialysis, Support, Reverse Osmosis	N	US	GPT	AT1	8'-6	3'-0	30-45	60	500	.	.	U	.	.	.	.	.	.	.	.	.	.	.	.	.	.	-	6	2	*	50	Y	.	.	Y	.
RECP1	Reception	4	SP	GPT	AT1	9'-0	3'-0	35-45	60	300	.	.	.	.	.	.	.	.	.	.	.	.	.	.	.	.	O	a	a	*	70	Y	14	.	.	.	.
RECP2	Reception, Administration	4	SP	GPT	AT1	9'-0	3'-0	35-45	60	300	.	.	.	.	.	.	.	.	.	.	.	.	.	.	.	.	O	a	a	*	70	Y	14	.	.	.	.
RECP3	Reception, Information Desk	4	SP	GPT	AT1	VAR	L	35-45	60	300	.	.	.	.	.	.	.	.	.	.	.	.	.	.	.	.	O	a	a	*	70	Y	14	.	.	.	.
RER01	Refrigeration Equipment Room	N	CS	GPT	SSP	VAR	4'-0	30-45	B	200	.	.	LS	E	.	.	.	.	.	.	.	.	.	.	.	.	-	a	a	SP	SP	Y	13	.	.	.	.
RMF01	Mask Fit, Respirator	4	UT	GPT	AT1	8'-0	3'-0	30-40	60	300	.	.	.	.	.	.	.	.	.	.	.	.	.	.	.	.	-	6	2	*	68	Y	13	.	Y	.	
RPR01	Copier	N	SP	GPT	AT1	8'-0	3'-0	30-45	100	500	.	.	.	.	.	.	.	.	.	.	.	.	.	.	.	.	O	10	2	*	70	Y	13	.	.	.	.
RPR02	Copier, High Volume	N	SP	GPT	AT1	8'-0	3'-0	30-45	150	700	.	.	.	.	.	.	.	.	.	.	.	.	.	.	.	.	O	10	2	*	70	Y	13	.	.	.	.
RRIR1	Recovery, Isolation	2	US	GLG	GLG	9'-0	4'-0	30-40	60	300	B	R	L	.	1	.	.	3	.	.	3	.	.	.	.	.	-	-	12	2	75	70	S	14	.	Y	O,Q
RRIP1	Recovery, Phase II	2	US	GLG	AT1	9'-0	4'-0	35-45	60	300	B	R	L	.	1	.	.	3	.	.	3	.	.	.	.	B	+	6	2	*	70	S	14	.	.	.	.
RRIP2	Recovery, Phase II, Multi-Station	2	US	GLG	AT1	9'-0	P	35-45	60	300	D	R	L	.	1	.	.	3	.	.	3	.	.	.	.	B	+	6	2	*	70	S	14	.	.	.	.

Room Code	ROOM FUNCTION	C/O ID	ARCHITECTURAL			STRUCTURAL			ELECTRICAL			MEDICAL GAS AND VACUUM						MECHANICAL																
			MATL	FIN		CLG DR & SIZ	FLR	LIGHT	ES PWR	PW LT N	M D L P M S O D N I G	A A A A V V E E O O A D N	W A	TEMP																				
FL	WL	CLG HT	STC	LD	LEV N													BLAC	OA	SM	WNRH	IN	FN	EX	N									
RRSS1	Recovery, Phase I	1	US	GLG	GLG 9'-0"	4'-0"	35-45	60	300 B	R	L	.	1	.	3	.	3	.	B	+ 6	2	75	70	S	14	14	.	.	O					
SEC01	Secretary	N	CP	GPT	AT1 8'-0"	3'-0"	30-40	60	500	.	.	.	.	.	.	.	.	.	.	O a	a	*	68	Y	13	.	.	.	.					
SEC02	Secretary, Command	N	CP	GPT	AT1 8'-0"	3'-0"	30-40	60	500	.	.	.	.	.	.	.	.	.	.	O a	a	*	68	Y	13	.	.	.	.	.				
SHWR1	Shower Room	4	CT	GCT	GLG 8'-0"	3'-0"	30-40	75	200	L	.	.	.	.	.	.	.	.	.	EX	10	.	68	Y	13	.	Y	.	.	.				
SINK1	Sink, Staff Handwashing		Space Parameter Notes: a																															
SL001	Staff Lounge	N	UT	GPT	AT1 8'-0"	3'-0"	35-45	60	300	.	.	.	.	.	.	.	.	.	.	O a	a	*	68	Y	13	.	.	.	.	.	.	.		
SRCH1	Storage, Charging, Battery / Equipment	4	UT	GPT	AT1 8'-0"	3'-6"	30-40	200	50	.	.	.	.	.	.	.	.	.	.	.	-	a	a	85	65	Y	13	.	Y	.	M	.		
SRCS1	Storage, Crutch / Splint	4	UT	GPT	AT1 8'-0"	3'-0"	30-40	125	100	.	.	.	.	.	.	.	.	.	.	.	O a	a	*	68	Y	13	.	.	.	.	.	.	.	
SRE01	Storage Room, Equipment	4	UT	GPT	AT1 9'-0"	3'-6"	35-45	D	100	.	.	.	.	.	.	.	.	.	.	.	O a	a	*	68	Y	13	.	.	.	.	.	.	.	
SRF01	Storage, Freezer, Walk-In	4	SP	SPF	SPF VAR	SP	.	275	200	.	.	.	.	.	.	.	.	.	.	.	O a	a	SP	SP	Y	13	.	.	.	.	.	.	.	
SRF02	Storage, Freezers, Freestanding	4	SP	GLG	GLG VAR	SP	30-45	B	200	.	.	.	.	.	.	.	.	.	.	.	O a	a	*	68	Y	13	.	Y	.	.	.	.	.	
SRGC1	Storage, Gas Cylinders, Exterior	4	CS	BPT	GPT 9'-0"	3'-0"	30-50	150	50	.	.	.	.	.	.	.	.	.	.	.	-	a	a	.	.	Y	.	Y	.	G	.	.	.	
SRGC2	Storage, Gas Cylinders, Interior	4	CS	GLG	GLG 8'-0"	3'-0"	30-45	150	200	.	.	.	.	.	.	.	.	.	.	.	-	a	a	*	68	Y	13	.	Y	.	G	.	.	.
SRHM1	Storage, Hazardous Material	4	CS	BPT	GPT 8'-0"	3'-0"	30-50	125	100	E	.	.	.	.	.	.	.	.	.	.	-	a	a	.	.	Y	13	.	Y	.	G	.	.	.
SRL01	Storage, Laboratory, Microscope Slides	4	UT	GPT	AT1 8'-0"	3'-0"	30-40	125	100	.	.	.	.	.	.	.	.	.	.	.	+	a	a	*	70	Y	13	.	.	.	.	.	.	.
SRL02	Storage, Laboratory, Paraffin Blocks	4	UT	GPT	AT1 8'-0"	3'-0"	30-40	125	100	.	.	.	.	.	.	.	.	.	.	.	+	a	a	*	70	Y	13	.	.	.	.	.	.	.
SRLW1	Storage, Wheelchair	4	UT	GPT	AT1 8'-0"	L	30-40	125	100	.	.	.	.	.	.	.	.	.	.	.	O a	a	*	70	Y	13	.	.	.	.	.	.	.	.
SRLW2	Storage, Litter	N	UT	GPT	AT1 8'-0"	L	30-40	125	100	.	.	.	.	.	.	.	.	.	.	.	O a	a	*	70	Y	13	.	.	.	.	.	.	.	.
SRPB1	Storage, Patient Baggage	4	UT	GPT	AT1 8'-0"	3'-0"	30-40	125	100	.	.	.	.	.	.	.	.	.	.	.	O a	a	*	68	Y	13	.	.	.	.	.	.	.	.
SRPS1	Storage, Parts	4	UT	GPT	AT1 8'-0"	3'-0"	30-40	125	100	.	.	.	.	.	.	.	.	.	.	.	O a	a	*	68	Y	13	.	.	.	.	.	.	.	.
SRR01	Storage, Refrigerator, Walk-In	4	SP	SPF	SPF VAR	SP	.	275	200	.	.	.	.	.	.	.	.	.	.	.	O a	a	.	.	Y	13	.	.	.	.	.	.	.	.
SRR02	Storage, Refrigerators, Freestanding	4	SP	GLG	GLG VAR	SP	30-40	B	200	.	.	.	.	.	.	.	.	.	.	.	O a	a	.	.	Y	13	.	.	.	.	.	.	.	.
SRS01	Storage, Shelving	4	UT	GPT	AT1 9'-0"	3'-0"	35-45	D	100	.	.	.	.	.	.	.	.	.	.	.	O a	a	*	68	Y	13	.	.	.	.	.	.	.	.

Room Code	ROOM FUNCTION	ARCHITECTURAL										STRUCTURAL			ELECTRICAL				MEDICAL GAS AND VACUUM						MECHANICAL							
		C ID	MATERIAL & FIN				NC		FLR LD	LIGHT LEV N	ES PWR		M A	D A	L A	P V	S E	O O	D D	N A	I G	W A	TEMP									
			FL	WL	CLG	DR & HT	SIZE	STC			PW	LT											N	BL	AC	OA	SM	WNRH	IN	FN	EX	N
SRS02	Central Storage Room, Medium	4	UT	GPT	AT1	9'-0"	3'-0"	35-45	D	100	.	.	.	.	.	.	.	.	.	.	.	O	a	a	*	68	Y	13	.	.	.	
SRS03	Central Storage Room, Large	4	UT	GPT	AT1	9'-0"	3'-0"	35-45	D	100	.	.	.	.	.	.	.	.	.	.	.	O	a	a	*	68	Y	13	.	.	.	
SRS04	Storage Room, Sterile	4	US	GLG	AT2	9'-0"	3'-0"	30-50	D	200	.	.	.	.	.	.	.	.	.	.	.	+	6	2	75	68	Y	13	.	.	.	
SRSE1	Storage, Equipment and Shelving	4	UT	GPT	AT1	9'-0"	3'-6"	35-45	D	100	.	.	.	.	.	.	.	.	.	.	.	O	a	a	*	68	Y	13	.	.	.	
SRVE1	Storage Room, Ventilator	4	UT	GPT	AT1	9'-0"	3'-6"	30-40	150	100	.	.	.	.	.	.	.	.	.	.	.	O	a	a	*	68	Y	13	.	.	.	
SSC01	Secure Storage, Cage	4	CS	GPT	AT1	9'-0"	SP	.	125	100	.	.	.	.	.	.	.	.	.	.	.	O	a	a	*	68	Y	13	.	.	.	
SSFE1	Secure Storage, Forensic Evidence	4	UT	GPT	AT1	8'-0"	3'-0"	30-40	125	300	.	.	.	.	.	.	.	.	.	.	.	O	6	2	*	68	Y	13	.	.	.	
SSS01	Secure Storage, Safe	4	UT	SSP	SSP	VAR	SP	.	C	100	.	.	.	.	.	.	.	.	.	.	.	O	a	a	.	.	Y	13	.	.	.	
SSV01	Secure Storage, Vault	4	CS	CCS	CCS	VAR	SP	.	125	100	.	.	.	.	.	.	.	.	.	.	.	O	a	a	*	68	Y	13	.	.	.	
TLTB1	Toilet, Bariatric	N	CT	GPT	GPT	8'-0"	4'-0"	30-40	75	200	.	.	.	.	.	.	.	.	.	.	.	EX	10	.	.	68	Y	13	.	Y	.	
TLTF2	Toilet, Public, Female	4	CT	GPT	GPT	8'-0"	3'-0"	35-45	75	300	.	.	.	.	.	.	.	.	.	.	.	EX	10	.	.	68	Y	13	.	Y	.	
TLTM2	Toilet, Public, Male	4	CT	GPT	GPT	8'-0"	3'-0"	35-45	75	300	.	.	.	.	.	.	.	.	.	.	.	EX	10	.	.	68	Y	13	.	Y	.	
TLTP1	Toilet, Psychiatric	4	CT	GPT	GPT	8'-0"	3'-6"	30-40	75	200	.	.	.	.	.	.	.	.	.	.	.	EX	10	.	.	68	Y	13	.	Y	.	
TLTP2	Toilet, Psychiatric, Seclusion	4	CT	GPT	GPT	8'-0"	L	30-40	75	200	.	.	.	.	.	.	.	.	.	.	.	EX	10	.	.	68	Y	13	.	Y	.	
TLTP3	Toilet / Shower, Psychiatric	4	CT	GCT	GLG	8'-0"	3'-6"	30-40	75	200	.	.	.	.	.	.	.	.	.	.	.	EX	10	.	.	68	Y	13	.	Y	.	
TLTS1	Toilet / Shower, Staff	N	CT	GCT	GLG	8'-0"	3'-0"	30-40	75	200	.	.	.	.	.	.	.	.	.	.	.	EX	10	.	.	68	Y	13	.	Y	.	
TLTS2	Toilet / Shower, Inpatient	4	CT	GCT	GLG	8'-0"	3'-0"	30-40	75	200	.	.	.	.	.	.	.	.	.	.	.	EX	10	.	.	68	Y	13	.	Y	.	
TLTU1	Toilet	4	CT	GPT	GPT	8'-0"	3'-0"	30-40	75	200	.	.	.	.	.	.	.	.	.	.	.	EX	10	.	.	68	Y	13	.	Y	.	
TRCS2	Procedure, Cystoscopic	2	US	LLG	GLG	9'-0"	VAR	30-40	60	500	D	.	.	.	1	.	.	1	.	.	.	+	15	3	*	73	Y	14	.	.	.	
TREE1	Procedure, Endoscopy	2	US	GLG	GLG	9'-0"	D	30-40	60	500	D	R	LS	.	1	.	.	2	.	.	1	.	--	12	2	*	73	S	14	.	Y	F
TREN1	Treatment, ENT	3	US	GLG	GLG	9'-0"	3'-6"	25-35	60	500	A,D	.	.	.	.	.	.	1	.	.	1	.	O	6	2	*	73	S	14	.	.	.
TREN2	Voice Lab	3	CP	GPT	AT1	VAR	3'-0"	SP	60	500	.	.	.	.	.	.	.	.	.	.	.	O	6	2	*	73	Y	14	.	.	.	
TRET1	Treatment, Emergency Trauma, Multi-Bed	1	US	GLG	GLG	9'-0"	H	30-40	60	1100	D	RA	LB	.	1	.	.	3	.	.	2	.	+	15	3	75	82	S	14	.	.	.

Room Code	ROOM FUNCTION	C/O	ARCHITECTURAL				STRUCTURAL		ELECTRICAL			MEDICAL GAS AND VACUUM						MECHANICAL																
			MATL & FIN			NC	FLR	LD	LIGHT	ES	PWR	D	L	W	A	TEMP			FN	EX	N													
			FL	WL	CLG											DR & SIZE	STC	LEV				N	PW	LT	N	M	D	L	P	M	S	O	D	N
			E	UT	GPT	AT2	STC	50*	1100	RA	LB	.	1	.	.	3	.	.	2	.	.	.	B	+	15	3	75	82	S	14	.	.	.	
TRET3	Treatment, Emergency Trauma	1	US	GLG	GLG	9'-0"	4'-0"	30-40	60	1100	D	RA	LB	.	1	.	.	3	.	.	2	.	.	B	+	15	3	75	82	S	14	.	.	.
TRET4	Treatment, Emergency Care	2	US	GLG	GLG	9'-0"	4'-0"	30-40	60	500	D	RA	LB	.	1	.	.	2	.	.	2	.	.	B	+	12	3	75	73	S	14	.	.	.
TRET5	Treatment, Emergency Care, Multi-Bed	2	US	GLG	GLG	9'-0"	P	30-40	60	500	D	RA	LB	.	1	.	.	2	.	.	2	.	.	B	+	12	3	75	73	S	14	.	.	.
TREY1	Treatment, Ophthalmology	3	US	GPT	AT2	9'-0"	3'-0"	30-40	60	500	A,D	LS	U	.	.	.	1	.	.	1	.	.	.	O	6	2	*	73	S	14	.	.	.	
TREY2	Treatment, Eye - Laser	2	US	GPT	AT2	8'-0"	3'-0"	30-40	60	700	A	LS	U	.	.	.	1	.	.	1	.	.	.	+	15	3	R	R	S	14	.	.	.	
TREY3	Treatment, Eye - LASIK / PRK	2	US	GLG	AT2	8'-0"	3'-6"	30-40	60	700	A	LS	U	.	.	.	1	.	.	1	.	.	.	+	15	3	R	R	R	14	17	.	O,P,V	
TRGM1	Treatment, General	3	US	GLG	GLG	9'-0"	4'-0"	30-40	60	500	D	LS	U	.	.	.	1	.	.	1	.	.	.	O	6	2	*	73	S	14	.	.	.	
TRGM2	Treatment, General, Multi-Bed	3	US	GLG	GLG	9'-0"	4'-0"	30-40	60	500	D	LS	U	.	.	.	1	.	.	1	.	.	B	O	6	2	*	73	S	14	.	.	.	
TRGS1	Treatment, General Surgical	3	US	GLG	GLG	9'-0"	4'-0"	30-40	60	500	D	LS	U	.	.	.	1	.	.	1	.	.	.	O	6	2	*	73	S	14	.	.	.	
TRGS2	Treatment, General Surgical, Airborne Infection Isolation	3	US	GLG	GLG	9'-0"	4'-0"	30-40	60	500	D	LS	U	.	.	.	1	.	.	1	.	.	.	--	12	2	*	73	S	14	.	Y	.	
TRGS3	Treatment, General Surgical, Laser	3	US	GLG	GLG	9'-0"	4'-0"	30-40	60	500	A,D	LS	U	.	.	.	1	.	.	1	.	.	.	O	6	2	*	68	S	14	.	.	.	
TROB1	Treatment, OB / GYN	C	US	GLG	GLG	9'-0"	4'-0"	30-40	60	500	D	LS	U	.	.	.	1	.	.	1	.	.	.	O	6	2	*	73	S	14	.	.	.	
TROR1	Procedure, Orthopaedic	3	US	GLG	GLG	9'-0"	4'-0"	30-40	60	500	D	LS	U	.	.	.	1	.	.	1	.	.	.	O	6	2	*	73	S	14	.	.	.	
TRPE1	Procedure, Proctoscopy (LGI)	2	US	GLG	GLG	9'-0"	4'-0"	30-40	60	500	D	R	LS	.	.	.	1	.	.	2	.	.	1	.	-	10	2	*	73	S	14	.	Y	.
TRPE2	Procedure, Bronchoscopy	2	US	GLG	GLG	9'-0"	4'-0"	30-40	60	500	D	R	LS	.	.	.	1	.	.	2	.	.	1	.	--	12	2	*	73	S	14	.	Y	.
TRSP1	Treatment / Recovery, Support Area	Space Parameter Notes: a																																
TUB01	Tub Room, Patient	3	CT	GCT	GLG	8'-0"	4'-0"	30-40	C	200	.	LS	.	.	.	.	.	.	.	.	.	.	.	EX	10	.	.	68	Y	13	.	Y	.	
UCCL1	Utility, Clean	4	UT	GPT	AT1	8'-0"	3'-6"	30-40	100	200	.	.	.	.	.	.	.	.	.	.	.	.	.	+	4	2	*	68	Y	14	.	.	.	
UCCL2	Utility, Scope Wash, Clean	4	US	GPT	AT1	8'-0"	3'-0"	30-40	100	200	.	.	.	.	.	.	.	.	.	.	.	.	.	+	4	2	*	68	Y	14	.	.	.	
USCL1	Utility, Soiled	4	UT	GLG	AT1	8'-0"	3'-0"	30-40	100	200	.	.	.	.	.	.	.	.	.	.	.	.	.	-	10	2	*	68	Y	13	.	Y	.	
USCL2	Utility, Scope Wash, Soiled	4	US	GLG	AT1	8'-0"	3'-0"	30-40	100	500	.	.	.	.	.	.	.	.	.	1	.	.	1	.	-	10	2	*	68	Y	14	.	Y	M
USDD1	Utility, Soiled, Detergent Dispensing	4	UT	GLG	AT1	8'-0"	3'-0"	30-40	C	200	.	.	.	.	.	.	.	.	.	.	.	.	.	-	10	2	*	68	Y	13	.	Y	.	
UTC01	Utility, Trash Collection	4	CS	GLG	GLG	8'-0"	3'-0"	30-40	125	200	.	.	.	.	.	.	.	.	.	.	.	.	.	-	10	1	*	68	Y	13	.	Y	.	

Room Code	ROOM FUNCTION	C/O	ARCHITECTURAL				STRUCTURAL		ELECTRICAL			MEDICAL GAS AND VACUUM					MECHANICAL																		
			MATL	FIN		NC	FLR	LD	LIGHT	ES	PWR	LT	N	M	D	L	P	S	O	D	N	I	G	W	A	TEMP	BL	OA	SM	WN	RH	IN	FN	EX	N
UTC02	Utility, Trash Can Decon	4	CS	CCS	GLG	8'-0"	3'-0"	30-40	B	50	.	.	.	.	.	.	.	.	.	.	.	.	.	.	.	-	10	1	.	.	Y	13	.	Y	.
UTLC1	Utility, Trash and Linen Collection	4	UT	GLG	GLG	8'-0"	3'-0"	30-40	C	200	.	.	.	.	.	.	.	.	.	.	.	.	.	.	.	-	10	1	*	68	Y	13	.	Y	.
UTMW1	Utility, Medical Waste Holding	4	UT	GLG	GAT1	8'-0"	3'-6"	30-40	100	200	.	.	.	.	.	.	.	.	.	.	.	.	.	.	.	-	10	2	*	68	Y	13	.	Y	.
UTR01	Utility, Waste Recycling	4	UT	GLG	GAT1	8'-0"	3'-6"	30-40	125	200	.	.	.	.	.	.	.	.	.	.	.	.	.	.	.	-	10	2	*	68	Y	13	.	Y	.
UTR02	Utility Room, Waste Pulper System	4	UT	GLG	GAT1	8'-0"	3'-0"	30-40	F	200	.	.	.	.	.	.	.	.	.	.	.	.	.	.	.	-	10	2	*	68	Y	13	.	Y	.
VCSS1	Veterinary, Instrument Preparation	N	AR	GEP	AT2	9'-0"	4'-0"	30-40	C	700	.	.	.	.	.	1	.	.	.	.	1	.	.	.	.	-	10	2	*	68	Y	14	.	Y	.
VCWA1	Veterinary, Cage Wash	N	ER	BEP	AT2	9'-0"	4'-0"	30-40	C	200	.	.	.	.	.	.	.	.	.	.	.	.	.	.	.	-	10	1	*	68	Y	13	.	Y	.
VEX01	Veterinary, Examination / Treatment	3	US	GEP	AT2	9'-0"	3'-0"	30-40	C	500	D	.	R	LB	.	.	.	.	.	.	.	.	.	.	.	O	4	2	*	68	Y	13	.	Y	.
VEX02	Veterinary, General Treatment	3	US	GEP	AT2	9'-0"	4'-0"	30-40	C	500	D	.	R	LB	.	1	.	.	1	.	.	.	.	.	.	-	4	2	*	68	Y	13	.	Y	.
VFIL1	Veterinary, Food Inspection Lab	N	US	GEP	AT2	9'-0"	4'-0"	30-40	C	500	.	.	LS	.	.	.	.	.	.	.	.	.	.	.	.	-	6	2	*	68	Y	14	.	Y	M
VFP01	Veterinary, Food Preparation	N	US	GEP	AT2	9'-0"	4'-0"	30-40	C	500	.	.	LS	.	.	.	.	.	.	.	.	.	.	.	.	+	6	2	*	68	Y	14	.	Y	.
VHAU1	Veterinary, Holding Area Utility / Storage	N	ER	BEP	AT2	9'-0"	4'-0"	30-40	C	150	.	.	.	.	.	.	.	.	.	.	.	.	.	.	.	-	6	2	*	68	Y	13	.	Y	.
VKAR1	Veterinary, Kennel Confine, Ante-Room	N	ER	GEP	GEP	9'-0"	4'-0"	30-40	C	100	.	.	.	.	.	.	.	.	.	.	.	.	.	.	.	-	10	5	*	68	Y	13	.	Y	L
VKEN1	Veterinary, Kennel Area In / Outside	N	ER	BEP	AT2	9'-0"	4'-0"	30-40	C	100	.	.	.	.	.	.	.	.	.	.	.	.	.	.	.	-	10	5	*	68	Y	13	.	Y	L
VKEN2	Veterinary, Kennel Confine Canine	N	ER	BEP	AT2	9'-0"	4'-0"	30-40	C	100	.	.	.	.	.	.	.	.	.	.	.	.	.	.	.	-	10	5	*	68	Y	13	.	Y	L
VKEN3	Veterinary, Kennel Confine Feline	N	ER	BEP	AT2	9'-0"	4'-0"	30-40	C	100	.	.	.	.	.	.	.	.	.	.	.	.	.	.	.	-	10	5	*	79	Y	13	.	Y	L
VLAH1	Veterinary, Large Animal Holding	N	ER	BEP	AT2	9'-0"	VET	30-40	C	100	.	.	LS	.	.	.	.	.	.	.	.	.	.	.	.	-	10	5	*	79	Y	13	.	Y	L
VLB01	Veterinary, Laboratory	N	ER	GEP	GEP	9'-0"	4'-0"	30-40	C	500	.	.	LB	.	.	.	.	.	.	.	.	.	.	.	.	-	6	2	*	68	Y	13	.	.	M
VLBF1	Veterinary, Lab, Food Inspection	N	AR	GEP	GEP	9'-0"	4'-0"	30-40	C	500	.	.	LB	.	.	.	.	.	.	.	.	.	.	.	.	-	6	2	*	68	Y	13	.	Y	.
VLBF2	Veterinary, Lab, Food Testing	N	AR	GEP	AT2	9'-0"	4'-0"	30-40	C	500	.	.	LB	.	.	.	.	.	.	.	.	.	.	.	.	-	6	2	*	68	Y	13	.	Y	.
VNEC1	Veterinary, Necropsy	4	ER	GEP	GEP	9'-0"	4'-0"	30-40	C	700	D	.	.	.	.	1	.	.	.	1	.	.	.	.	.	-	12	3	R	R	Y	13	.	Y	M
VPH01	Veterinary, Pharmacy	N	ER	GEP	GEP	9'-0"	4'-0"	30-40	C	1100	.	.	R	L	.	.	.	.	.	.	.	.	.	.	.	+	4	2	*	68	Y	13	.	.	.
VRHA1	Veterinary, Rodent Holding	N	ER	BEP	GEP	9'-0"	VET	30-40	C	100	.	R	LS	.	.	.	.	.	.	.	.	.	.	.	.	-	15	15	*	79	Y	13	.	Y	.



Room Code	ROOM FUNCTION	C/O	ARCHITECTURAL				STRUCTURAL		ELECTRICAL			MEDICAL GAS AND VACUUM						MECHANICAL																	
			MATL & FIN		NC		FLR	LD	LIGHT	ES	PWR	M	D	L	P	S	O	D	N	I	G	W	A	BL	AC	OA	SM	W	N	R	H	IN	FN	EX	N
			FL	WL	CLG	DR & SIZE																													
XCTC1	X-Ray, Computed Tomography, Control	4	US	GLG	AT1	8'-0"	3'-0"	30-40	100	300	A													O	6	2	*	70	Y	13					
XCTC2	X-Ray, Computed Tomography, Component	4	US	GLG	AT1	8'-0"	4'-0"	30-40	C	300														O	4	2	*	68	Y	13					N
XCTI1	X-Ray, Computed Tomography, Independent View Console	4	US	GLG	AT1	8'-0"	3'-0"	30-40	100	300	A													O	4	2	*	70	Y	13					N
XCTS1	X-Ray, Computed Tomography, Scanner	C	US	LLG	AT1	VAR	4'-0"	30-40	100	500	D,I													O	6	2	*	73	Y	14					
XDBD1	X-Ray, Bone Densitometer	3	US	GLG	AT1	9'-0"	4'-0"	30-40	100	500														O	6	2	*	73	Y	14					
XDCS1	X-Ray, Chest	3	US	LLG	AT1	10'-0"	4'-0"	30-40	100	500	A													O	6	2	*	73	Y	14					
XDCY1	X-Ray, Cystology / Radiology	2	US	LLG	AT1	10'-0"	4'-0"	30-40	100	500	D,I													O	6	2	*	73	Y	14					
XDM01	X-Ray, Mammo	3	US	LLG	AT1	9'-0"	4'-0"	30-40	100	500	A													O	4	2	*	73	Y	14					
XDM02	X-Ray, Mammo, Stereotactic	2	US	LLG	AT1	9'-0"	4'-0"	30-40	100	500	A													O	6	2	*	73	Y	14					
XDMP1	X-Ray, Mammo, Process	4	US	GLG	AT1	8'-0"	3'-0"	30-40	100	500	A													-	10	2.5	*	73	Y	14		Y		M	
XDR01	X-Ray, Radiographic, General	3	UT	LLG	AT1	9'-6"	4'-0"	30-40	100	500	I													O	6	2	*	73	Y	14					
XDRF1	X-Ray, Rad / Fluoro	C	UT	LLG	AT1	9'-6"	4'-0"	30-40	100	500	I													O	6	2	*	73	Y	14					
XDUS1	X-Ray, Ultrasound	3	UT	GPT	AT1	8'-0"	4'-0"	30-40	100	500	A													O	6	2	*	73	Y	14					
XFDS1	X-Ray, Storage, Digital Files	4	UT	GPT	AT1	8'-0"	3'-0"	30-40	100	300														+	6	1	*	68	Y	13					N
XFFA1	X-Ray, Storage, Film Files, Fixed Shelves	4	UT	GPT	AT1	VAR	3'-0"	30-40	250	300														O	4	2	*	68	Y	13					
XFFA2	X-Ray, Storage, Film Files, Mobile Shelves	4	UT	GPT	AT1	VAR	3'-0"	30-40	350	300														O	4	2	*	68	Y	13					
XMRC1	X-Ray, Magnetic Resonance, Control	4	UT	GLG	AT1	8'-0"	3'-0"	30-40	100	300	A													O	4	2	*	68	Y	13					
XMRC2	X-Ray, Magnetic Resonance, System Component	4	UT	GLG	AT1	8'-0"	4'-0"	30-40	100	300														O	4	2	*	68	Y	13					N
XMRE1	X-Ray, Magnetic Resonance, Equipment	4	UT	GLG	AT1	8'-0"	4'-0"	30-40	100	300														O	4	2	*	68	Y	13					
XMRF1	X-Ray, Magnetic Resonance, Ferromagnetic Detection	4	UT	GLG	AT1	8'-0"	4'-0"	30-40	100	300		R												O	4	2	*	68	Y	13					
XMRS1	X-Ray, Magnetic Resonance, Scanner	3	UT	GLG	AT1	VAR	4'-0"	30-40	C	300	I													O	6	2	*	73	Y	14					
XMRV1	X-Ray, Magnetic Resonance, Viewing	4	UT	GLG	AT1	8'-0"	3'-0"	30-40	100	300														O	4	2	*	68	Y	13					
XPCC1	X-Ray, SPECT / PET / CT Control	4	US	GLG	AT1	8'-0"	3'-0"	30-40	100	300	A													O	4	2	*	70	Y	13					N

Room Code	ROOM FUNCTION	C O I D	ARCHITECTURAL			STRUCTURAL		ELECTRICAL			MEDICAL GAS AND VACUUM					MECHANICAL																
			MATL & FIN	CLG	DR & NC	FLR	LIGHT	ES	PWR	M	D	L	P	S	O	D	N	I	G	W	A	TEMP	BLAC	OA	SM	WNRH	IN	FN	EX	N		
XPCC2	X-Ray, SPECT / PET / CT Component	4	US	GLGAT1	8'-0	4'-0	30-40	100	300	A	.	.	.	.	.	.	.	.	.	.	.	O	6	2	*	70	Y	13	.	.	.	N
XRM01	X-Ray, Storage, Mobile Rad Unit	4	UT	GPT	AT1	8'-0	L	30-40	100	150	.	.	.	.	.	.	.	.	.	.	.	O	.	.	.	Y	13	.	.	.	.	
XTBC1	X-Ray, Brachytherapy, Control	4	US	GLGAT1	8'-0	3'-0	30-40	E	300	A	R	.	.	.	.	.	.	.	.	.	.	O	4	2	*	70	Y	13	.	.	.	N
XTBT1	X-Ray, Brachytherapy	2	UT	LLG	AT1	8'-6	4'-0	30-40	100	700	A	.	LB	U	1	.	.	1	.	.	1	.	.	.	.	Y	14	.	Y	.	.	
XTEM1	X-Ray, Therapy, Entry Maze	4	US	GLGAT1	10'-0	SP	30-40	C	200	.	.	LS	.	.	.	.	.	.	.	.	.	O	6	2	*	68	Y	13	.	.	.	.
XTLA1	X-Ray, Therapy, Linear Accelerator	3	US	GLGAT1	10'-0	4'-0	30-40	C	500	D,I	.	LB	.	.	.	1	.	.	1	.	.	O	6	2	*	73	Y	14	.	Y	.	.
XTLA2	X-Ray, Therapy, Linear Accelerator, High Voltage	3	US	GLGAT1	10'-0	4'-0	30-40	C	500	D,I	.	LB	.	.	.	1	.	.	1	.	.	O	6	2	*	73	Y	14	.	Y	.	.
XTLA3	X-Ray, Therapy, Linear Accelerator, Dual Voltage	3	US	GLGAT1	10'-0	4'-0	30-40	C	500	D,I	.	LB	.	.	.	1	.	.	1	.	.	O	6	2	*	73	Y	14	.	Y	.	.
XTLB1	X-Ray, Therapy, Physics Laboratory	4	US	GLGAT1	9'-0	3'-0	30-40	100	500	.	.	.	.	.	.	.	.	.	.	.	.	-	6	2	*	70	Y	13	.	.	.	.
XTLC1	X-Ray, Therapy, Linear Accelerator, Control	4	US	GLGAT1	8'-0	4'-0	30-40	100	300	A	.	.	.	.	.	.	.	.	.	.	.	O	6	2	*	68	Y	13	.	.	.	.
XTLE1	X-Ray, Therapy, Linear Accelerator, System Component	4	US	GLGAT1	VAR	3'-0	30-40	100	500	A	.	LB	U	.	.	.	.	.	.	.	.	O	4	2	*	68	Y	14	.	.	.	N
XTMF1	X-Ray, Therapy, Mold Fabrication Shop	4	US	GLGAT1	9'-0	3'-0	30-40	100	500	.	.	.	.	.	.	.	.	.	.	.	.	-	6	2	*	68	Y	13	.	Y	.	M
XTRT1	X-Ray, Therapy, Radium Treatment Storage / Preparation	4	US	LLG	AT1	8'-0	3'-0	30-40	100	500	.	.	.	.	.	.	.	.	.	.	.	-	6	2	*	68	Y	13	.	Y	.	M
XTSC1	X-Ray, Therapy, Simulator Control	4	US	GLGAT1	8'-0	3'-0	30-40	100	300	A	.	LB	.	.	.	.	.	.	.	.	.	O	6	2	*	68	Y	13	.	.	.	.
XTSC2	X-Ray, Therapy, Simulator, System Component	4	US	GLGAT1	8'-0	4'-0	30-40	C	300	A	.	.	U	.	.	.	.	.	.	.	.	O	4	2	*	68	Y	13	.	.	.	N
XTSG1	X-Ray, Therapy, Simulator Gantry	4	US	GLGAT1	10'-0	4'-0	30-40	100	300	.	.	.	.	.	.	1	.	.	1	.	.	O	6	2	*	70	Y	13	.	.	.	.
XTSM1	X-Ray, Therapy, Simulator, Magnetic Resonance	4	UT	GLGAT1	VAR	4'-0	30-40	E	300	I	.	.	.	1	.	.	1	.	1	.	1	.	O	6	2	*	73	Y	14	.	.	.
XTPP1	X-Ray, Therapy, Treatment Planning	4	UT	GLGAT1	8'-0	3'-0	30-40	100	500	.	.	.	.	.	.	.	.	.	.	.	.	O	6	2	*	70	Y	13	.	.	.	.
XVC01	X-Ray, Viewing / Consultation	4	UT	GPT	AT1	8'-0	3'-0	30-40	60	300	A	.	LS	U	.	.	.	.	.	.	.	O	4	1	*	68	Y	13	.	.	.	.



## **APPENDIX C DESIGN SUBMITTALS AND DOCUMENTATION**

### **C-1 GENERAL.**

This appendix contains mandatory criteria for submittals and documentation. It addresses narratives, drawings, calculations, and cost estimates required at various submission levels during the production of construction contract documents for each project.

### **C-2 APPLICATION.**

The submission requirements in this appendix identify minimum information that must be provided under each submission level. The Design and Construction Agent must develop additional specific submission requirements as required.

### **C-3 GENERAL REQUIREMENTS.**

These general requirements apply to all projects, acquisition types and submittal requirements.

#### **C-3.1 Narratives and Format.**

Narratives must describe architectural, interior design, and engineering design features of a project across all disciplines. The narrative portion of all submittals must include written descriptions, calculations, cost estimates, specifications, and equipment lists, and be packaged in standard U.S. three-ring binders with labeled subject dividers, sequential page numbers, and table of contents. Date and properly identify all documents according to project title and level of submission. Project title must exactly reflect that which is noted on the enacted DD Form 1391.

#### **C-3.2 Drawings and Format.**

Drawing format and submissions must be as required by the Design and Construction Agent and the following.

##### **C-3.2.1 Building Information Modeling (BIM)**

Reference Chapter 18 Building Information Modeling (BIM), for specific execution. Compact disc submissions must include at a minimum BIM, CAD, and PDF files. Submittals to Health Information Technology (HIT) must commence with the 65% submittal stage.

##### **C-3.2.2 Perspective Drawing Sketch and Final Rendering.**

###### **C-3.2.2.1 Perspective Drawing Sketch.**

The perspective drawing sketch must best depict the proposed facility and its prominent design features as directed by the Design and Construction Agent. This sketch must be the basis for subsequent rendering requirements.

#### **C-3.2.2.2 Rendering.**

A final rendering must be prepared from the perspective drawing sketch that reflects all review comments. Digital copies of the photo-realistic rendering must be provided to DHA/FE by the Design and Construction Agent via CD electronic format, or in framed format on a case by case basis when so requested by the DHA/FE. The framed photographs must be titled, single matted, framed, and glazed with non-glare tempered glass or plexi-glass. The frame must be 28 inches by 20 inches in dimension and of a brushed aluminum finish. Other photographs must be distributed as determined by the Design and Construction Agent.

#### **C-3.3 Building Systems Risk Assessment.**

Not later than the 20 percent design (DBB process) submission, the Architect-Engineer (A/E) must conduct a risk assessment to confirm or establish the Building System Category for each of the various facility systems in accordance with NFPA 99. For the DB process, the assessment must be conducted by the A/E, and included as part of the RFP development. In all cases, the assessment must be fully coordinated with the appropriate Department of Defense Components at each submittal milestone, and document system requirements necessary to adequately safeguard occupant safety, health, and comfort based on the intended CONOPS and acuity of the patient population to be served by that facility. The completed Risk Assessment will be provided to DHA/FE by the Design and Construction Agent for concurrence.

#### **C-4 5 PERCENT SUBMITTAL.**

##### **C-4.1 5 Percent Submittal Narratives.**

The narratives include pros and cons of presented block plans, preliminary site information, and architectural, transportation, and engineering considerations. Provide an Executive Summary of the 5 Percent Report documenting the selected solution to be further developed to 20 percent design.

##### **C-4.2 5 Percent Submittal Drawings.**

###### **C-4.2.1 Site Plans.**

The A/E must develop and present alternative site plans supporting the three block plan proposals. For each site plan, show the following:

- a. Site Master Plan of each alternative and include; location and orientation of all new building structures, Installation impacts, adjacent building/structures impact, environmental adjacencies, roads, paths and service access, previous demolished structures, potential site contaminants ( firing range, fuel containment, etc) and known utilities location/layout overview. Include existing structures (note whether they are to remain or be considered for demolition).
- b. Antiterrorism standoff distances.

- c. Desirable site views, natural weather conditions, e.g., wind/sand storms and seasonal sun orientation
- d. Existing site topography that may impact building development.
- e. Major utility connection locations (points of origin).
- f. On- and offsite vehicular and service traffic patterns to include primary and secondary roadways surrounding the site.
- g. Parking recommendations (surface or structured).
- h. Future building expansion (maximum 20 percent of the enacted DD Form 1391 gross building area [in gross square feet (GSF)]); include future parking structure locations as applicable.
- i. Site noise/sound, smell generating conditions, e.g., proximity to major highway, adjacency to an airport, sewage treatment, etc.
- j. Optional location or methodology to incorporate the VA or other organization's program, if applicable.

#### **C-4.2.2 Block Plans.**

Up to three block plans and site access/orientation studies must be developed to convey the project requirements. Each block plan must show floor to floor and departmental relationships; exterior elevation views; location of vertical and horizontal transportation systems, e.g., elevators, escalators, and stairs; interior circulation patterns; operational movement of materials, supplies and people; and impacts to corridor widths due to transportation solutions or other unique conditions, e.g., AGVs, IBS, or similar systems. Include principle key dimensions. Site access/orientation must show placement of the facility and drives on the selected site, neighboring issues that may impact the project, and must convey pedestrian and vehicular movement across and within the site. The site plan should identify and convey restrictions that may impact the placement and orientation of the facility. The A/E must develop a final block plan representative of the selected solutions for the 20 percent submittal.

#### **C-4.2.3 Addition/Alteration Projects.**

Clearly delineate the extent and scope of renovations and alterations, including all associated work in these areas such as; connections, demolition, finishes, upgrades, utilities, ductwork, IT support, etc.

#### **C-4.3 5 Percent Submittal Cost Estimates.**

##### **C-4.3.1 Parametric Cost Estimates.**

Provide a parametric cost estimate for each block plan developed, including any requested design solution(s) that could exceed the budget.

## **C-5 20 PERCENT SUBMITTAL.**

This Submittal includes development of the room-by-room floor plans, building elevations, and preliminary analysis of major architectural and engineering systems based on the selected block plan. It identifies and resolves all major PFD changes, solidifies all space requirements, coordinates departmental or mission realignment, and ensures that the designed scope complies with the appropriate authorization scope.

The Submittal must illustrate the building massing, aesthetics, exterior finishes, and identify specific architectural and engineering features. Include O&M access for primary MEP and communication equipment, primary distribution pathways, storm-water management strategy to meet the requirements of EISA, establish the cost and scope for providing necessary utility services to and from the building, and identify major building entrances from parking and pedestrian paths of travel. The Submittal must consider and establish preliminary phasing considerations and scope impacts, and address transportation, logistics, and waste management requirements of the facility.

### **C-5.1 Scope Changes.**

Requests for scope changes must be submitted by the Using Agency to DHA/FE with the 20 Percent Submittal. Scope changes are defined as those that materially affect the characteristics of the facilities (e.g. Category Code) or increase the GSF as defined in Block 8 of the DD1391. Refer to Chapter 3 Design. Develop a clear justification and basis for any increases to the GSF, e.g., mission changes, workload increases, and increases in troop numbers due to troop or unit reassignments.

### **C-5.2 Record Copy.**

The Design and Construction Agent must submit a record copy of the 20 percent submittal to DHA/FE. No approval from DHA/FE is required at the 20 percent submittal. However, a presentation to DHA/FE will be required if the project has exceeded the authorized scope or is over budget.

### **C-5.3 20 Percent Design Narratives.**

The following are minimum 20 Percent Design Narrative Submittal describing proposed architectural and engineering aspects of the project. The narratives must be provided to the Design and Construction Agent and to DHA/FE in CD electronic format. List all mandatory criteria, codes and standards with which the project must comply.

#### **C-5.3.1 Executive Summary.**

The executive summary must include this narrative information:

- a. Rationale for the selected block plan scheme;
- b. Proposed architectural and engineering systems;

- c. Approach to sustainable design, energy reduction, and other related energy compliant features to the project;
- d. Designed scope and budget compared to the authorized scope and budget;
- e. Specific military base requirements impacting the design of the project, e.g., building exterior finishes, excessive noise factors, and other site/building constraints; and
- f. Utility services available and their points of entry into the project's site, including privatized utilities and their impact on scope and cost to the project.

### **C-5.3.2 World-Class Checklist.**

A World-Class Checklist in accordance with the World Class Toolkit requirements must be developed for every project providing direct patient care and must include all architectural and engineering disciplines. It must be applied across the entire life of a project, from conception to recapitalization, and apply to additions, renovations, and restoration of a facility. For addition/renovation projects, refer to the original project's World-Class Checklist and documentation to ensure these standards are maintained and continued.

### **C-5.3.3 Civil.**

Refine the 5 percent submittal site investigation and utilities report. Discuss approach to Storm-water Management and "Low Impact Development".

### **C-5.3.4 Architectural.**

Address the overall architectural concept including: exterior wall systems and finish materials, acoustics, base architectural plan, floor-to-floor heights, roofing materials, slope(s), styles, energy conservation features, sustainable design, commissioning, life safety, and fire protection. Describe how proposed material selections and finishes must support aseptic environments, infection control and patient/staff safety.

### **C-5.3.5 Interstitial Building System (IBS).**

If approved, the narrative must address IBS to include its design, documentation, and technical requirements in accordance with Appendix E Interstitial Building System.

### **C-5.3.6 Structural.**

Discuss and describe the justification and basis for the proposed system.

### **C-5.3.7 Seismic.**

Discuss the seismic design considerations and the level of protection required. Evaluate the seismic impacts to the structural design system being proposed for new

facilities. For addition/alteration projects, provide a preliminary Facility Upgrade Report that includes a Seismic Structural Assessment and Evaluation Study.

#### **C-5.3.8 Heating, Ventilation, and Air Conditioning.**

Discuss design considerations and space requirements for the primary and secondary HVAC systems being considered and how they compare based on Life Cycle cost Analysis. Also, explain how the design must provide weather-protection; direct floor-to-ground access for equipment O&M, e.g., pallet transport via hydraulic hand carts; and practical means of future replacement.

#### **C-5.3.9 Plumbing.**

Discuss design considerations and space requirements for the various plumbing systems to include: domestic hot and cold water, e.g., water supply, quality, hot water generation, storage requirements, temperatures; and distribution systems, fuel gas, medical gases (types, storage, and distribution systems), sanitary waste and vent, and storm drains. Address compliance with post-seismic storage and water conservation criteria and regulations, if applicable.

#### **C-5.3.10 Electrical.**

Address design considerations and space requirements for electrical systems. In particular, discuss: voltage, routing, and reliability of primary services; connected and demand load; normal and essential electrical systems; emergency power; lighting systems; and energy conservation features. Include in the discussion earthquake impacts to normal and alternate power, and vulnerability to the electrical distribution system, switches, and other features serviced by these power systems.

#### **C-5.3.11 Communications.**

Discuss design considerations and space requirements for all communications systems required for the project.

#### **C-5.3.12 Fire Protection.**

Address the fire detection, alarm, and suppression systems and features for the facility.

#### **C-5.3.13 Life Safety.**

Address the type of construction, fire rating of materials, and occupancy classification for the facility. For addition/alteration projects, provide an LSA Report. Reference paragraph 14-6.1, Life Safety Assessment.

#### **C-5.3.14 Physical Security.**

Discuss the physical security system design, consideration, parameters, major features, and space requirements for the overall facility and specialized areas such as those processing classified or sensitive information. Refer to Appendix A for requirements for Behavioral Health.

**C-5.3.15 Antiterrorism/Force Protection (AT/FP).**

Discuss site, design, space considerations and requirements for AT/FP systems. Project must conform to requirements of UFC 4-010-01. Deviations to include improvements or detriments to the UFC 4-010-01 standards must remain within the limits specified by UFC 4-010-01 Section 1-1.3.2 and all requirements of the remaining document.

**C-5.3.16 Sustainability and Energy Conservation Compliance.**

Discuss status toward meeting project goals, known and potential sustainable rating system points, and initial calculated energy costs and energy consumption status relative to the ANSI/ASHRAE 90.1 baseline. This narrative must include separate sections for Architecture, Site, Mechanical, and Electrical. Include proposed checklist.

**C-5.3.17 Commissioning.**

A preliminary Commissioning Plan must be developed and submitted that defines the method by which commissioning must be performed. The Commissioning Plan must outline and define its processes to include; commissioned systems, participants, roles and responsibilities, communication procedures, and deliverables. Discuss procedures for achieving required commissioning of all commissioned systems. Reference Chapter 19 Commissioning for additional information.

**C-5.3.18 Transportation and Logistics.**

Provide a preliminary, overall TLS that discusses the rationale for the proposed transportation, logistics, waste management, and food service solutions. The TLS must include impacts to programmed scope and cost and: (1) an Elevator Traffic Analysis and Study, (2) an LCCA for automatic and manual material handling systems, (3) a Waste Management Study (WMS), and (4) a Food Service Study, as applicable. The Waste Management Study must include the major design parameters and features that address trash removal; hazardous, infectious, and biological waste; retort sterilizers; incinerators; and other waste handling features of the design. See Chapter 16 Transportation and Logistics and Appendix F Food Service for additional requirements regarding these studies. In addition, address and discuss PTS's, as well as dumbwaiters and AGV systems.

**C-5.3.19 Wayfinding.**

A preliminary wayfinding master plan must be provided that addresses necessary orientation cues and information for patients, staff and visitors who navigate in and around a facility. Identify environmental paths, edges, regions, nodes, and landmarks used to successfully move from one destination to another. Analyze a facility's spatial organization and layout to identify specific areas, directional challenges, and wayfinding tools that can help in navigation. Consider all types of functions and activities a person must perform when in a Military Medical Facility. Reference Chapter 6 Architectural for further requirements in developing a wayfinding master plan.

#### **C-5.3.20 Food Service.**

If applicable, discuss the food service design and considerations to include optimal movement of food products to ensure effective monitoring and control of food temperatures through conventional flow while minimizing personnel cross-traffic, backtracking, and queuing conditions.

#### **C-5.3.21 Construction Phasing.**

When required by the Design and Construction Agent, develop a written narrative of the overall requirements for a phased approach to the construction that addresses all work associated with all the major disciplines. Develop a preliminary construction phasing plan that addresses “major” areas of work requiring specific parameters, sequence, or milestones. This phasing plan is not a typical technical sequence of normal construction work, but describes any situation that would prevent the contractor from doing all areas of the work simultaneously or at his discretion. Preliminary identification of phased areas and durations should be identified with reference to scope, constructability, timing, and overall construction length. Requirements unique to phased projects such as swing space, utilities that must have to serve two areas simultaneously, demolition sequence, and engineering system support for isolated or independent areas, must be addressed in reference to the operational, constructability, and cost constraints of the project.

#### **C-5.3.22 Addition/Alteration Projects.**

For addition/alteration projects, develop and discuss a preliminary construction phasing plan that supports continued/uninterrupted operations of the existing facility during construction and associated impact on construction costs and scope. Identify the requirements for temporary buildings to serve as swing space. In addition, identify actions that reduce or interrupt service to an existing, occupied area. Identify potential temporary connections, extensions of service that increase system demand, locations of new connections, or other measures necessary to sustain service for engineering systems within the existing building.

#### **C-5.4 20 Percent Submittal Design Drawings.**

The following are minimum 20 percent submittal drawings depicting proposed architectural and engineering aspects of the project, and must be provided in electronic format. DHA/FE requests ½ size drawings format.

##### **C-5.4.1 Architectural Drawings.**

Provide floor plans for each floor showing all programmed spaces and corridors; key building dimensions; structural grid system (including columns and type of system proposed) and key building dimensions; electrical and mechanical equipment rooms; stairs, elevators, and escalators; transportation equipment for movement of material and supplies; and specific locations of vertical and horizontal transportation systems, e.g., pneumatic tubes, dumb waiters, automated guidance systems, elevators, escalators, and stairs. All spaces identified in the PFD must be labeled with the Room Name and



Room Code, in addition to the programmed and designed net areas. Also, addition/alteration projects must include preliminary demolition drawings with photographs depicting existing conditions. Provide preliminary exterior elevations with proposed finishes.

**C-5.4.2 Interstitial Building System (IBS).**

If approved for project, a preliminary IBS design must be developed, e.g., plans and sections, that delineates interdisciplinary cross-sections at critical locations.

**C-5.4.3 HVAC, Plumbing, and Electrical Plans.**

Provide plans showing single line drawings of the distribution systems of major MEP, and communications from these spaces to the areas served. MEP space designs must be based on estimates of equipment capacity and building demand.

**C-5.4.4 Food Service Plans.**

If applicable, provide plans showing an initial layout of food service areas. Show circulation paths from servers to seating, loading dock to storage, kitchen to inpatient units, general material movement, principal dimensions, and dining seating counts. Optimize movement of food products and minimize personnel cross-traffic, backtracking, and queuing conditions. Reference Appendix F Food Service for additional requirements.

**C-5.4.5 Construction Phasing Plan.**

When required by the Design and Construction Agent, provide a graphic "Node" diagram of major elements and areas showing proposed sequential and parallel phased work. Indicate interim swing space, temporary facilities and locations of existing and relocated functions.

**C-5.4.6 Addition/Alteration Projects.**

For addition/alteration projects, update and continue to differentiate where existing conditions end and new conditions begin. Define extent and scope of renovations. Provide documentation of existing conditions.

- a. Existing building as-builts.
- b. Statement of conditions.
- c. Existing/Prior hazardous material abatement reports and studies

**C-5.5 20 Percent Submittal Calculations.**

Provide the 20 Percent Submittal Calculations to the Design and Construction Agent. DHA/FE requests CD electronic format only.

### **C-5.5.1 A/E Calculations.**

All calculations that support A/E features within the design must be provided. Supporting documentation must include life cycle cost analysis (LCCA) per UFC 1-200-02, to include energy systems, renewable systems, LED lighting, solar hot water use, and utility demand. Documentation should also include validation of the parking requirements.

### **C-5.5.2 Gross/Net Area Tabulations.**

Gross and net area tabulations for all floors must be submitted with a small-scale, single-line, dimensioned key plan, must be provided to reflect the total space required per Chapter 3 Design. Provide a departmental area summary tabulation to include; net areas, net to gross area and factor, and net area difference. Functional areas and or rooms must address room quantity, net area, and total area comparing the net as-designed area against the PFD values. Comparison must include: net areas, departmental gross areas, minimum grossing ratios, and building gross area. Provide justification if deviation between as-designed and PFD values is +/- 10 percent, except for rooms programmed for 50 SF or less.

### **C-5.5.3 20 Percent Submittal Cost Estimates.**

Provide schematic cost estimates in CD electronic format reflecting all design features and elements. Update all project costs based on refined project design details. Provide an updated DD Form 1391. Show PCAS and "Other" special cost as separate line items.

## **C-6 35 PERCENT SUBMITTAL**

This submittal is a minimum 35 percent of the total design across all disciplines and incorporates response to all review comments. This is considered the "technical submission" in which all major architectural and engineering systems and A/E design decisions are finalized into the project scope and costs. Load demand, equipment sizing, energy consumption, LCC, life safety, and other calculations for all building systems and features defined herein must be required and reflected in the cost estimate. Provide a Physicist Report for all radiation areas. Additional submission requirements must be defined by the Design and Construction Agent. The 35 percent design must be reviewed by the Design and Construction Agent, Using Agency and DHA/FE. A formal presentation to DHA/FE will be required. DHA/FE will provide review comments on the 35 percent Submittal with appropriate authority to proceed to 100% Design within 14 days of the formal presentation. Final changes to the project's enacted DD Form 1391 description, justification, and execution timelines are made at this submittal level. The following are the minimum requirements for the 35 percent design submittal:

### **C-6.1 35 Percent Submittal Design Narratives.**

Concept design narratives describing further refinement of the 20 percent design requirements to a 35 percent design effort must be provided as noted here:

**C-6.1.1 World-Class Checklist.**

Update the draft World-Class Checklist..

**C-6.1.2 Civil.**

Include the site investigation and utilities reports. Summarize the civil design parameters, parking, and major features of the design.

**C-6.1.3 Architectural.**

Address the overall architectural concept including interior design (in accordance with Appendix B Architectural and Engineering Design Requirements) and exterior finish materials, wall systems, roofing systems, acoustics, base architectural plan, floor-to-floor heights, and contingency and mobilization features. Provide a final functional narrative that describes alignment of the design with the design CONOPS developed for the project. See the CONOPS sections of Chapter 1 Introduction, Chapter 2 Predesign, and Chapter 3 Design. Describe how proposed material selections and finishes must promote aseptic environments and infection control and patient/staff safety.

**C-6.1.4 Interstitial Building System (IBS).**

If approved, update the design parameters and major features, including interstitial space considerations.

**C-6.1.5 Structural.**

Address the selected structural foundation and framing systems considered and provide an economic basis for system selection. Summarize the structural design parameters and major features of the design.

**C-6.1.6 Seismic.**

Summarize the seismic design considerations including “S” values and the level of protection required. Discuss post-earthquake operation requirements. For alteration and repair projects, complete the Facility Upgrade Report.

**C-6.1.7 HVAC.**

Provide a summary of the primary and secondary HVAC systems considered and the economic basis for system selection. Summarize the proposed control systems, fire protection features, and the energy conservation features being considered. Provide preliminary heating and cooling load calculations utilized in determining the preliminary equipment selections.

**C-6.1.8 Plumbing.**

Describe the various plumbing systems to include domestic hot and cold water, fuel gas, sanitary waste and vent, and storm drains. Summarize the water supply, quality, required storage, and distribution systems. Discuss hot water generation, storage,

temperatures, and distribution systems. Address various types of medical gases, storage, and distribution systems.

**C-6.1.9 Electrical.**

Summarize the electrical design parameters and the major features of the design. Address voltage, routing, and reliability of primary services; connected and demand load; normal/essential/emergency electrical systems; lighting systems; and energy conservation features. Provide cut sheets for all electrical equipment.

**C-6.1.10 Communication.**

Summarize all communication system design parameters and major features. Provide cut sheets for all communications equipment.

**C-6.1.11 Fire Protection.**

Summarize the fire protection system design parameters and major features to include: fire detection, alarm, and suppression systems. For addition/alteration projects, provide a summary of the analysis of the FSES Study. Include related design considerations and criteria that have been coordinated among all the affected disciplines.

**C-6.1.12 Life Safety.**

Summarize the life safety considerations, design parameters, and major features. Address type of construction, fire rating of materials, life safety features, and occupancy classification. For addition/alteration projects, provide a summary of the analysis of the latest LSA Report.

**C-6.1.13 Physical Security.**

Summarize the security system design parameters and major features.

**C-6.1.14 Antiterrorism/Force Protection (AT/FP).**

Summarize the AT/FP system design parameters and major features.

**C-6.1.15 Sustainability and Energy Performance/Conservation Compliance.**

Identify status toward reaching sustainable certification by providing a matrix listing and briefly describing achievable and potential “points” with economic impact. Identify energy cost reduction and energy conservation compliance relative to ANSI/ASHRAE 90.1 baseline. Discuss all energy conservation design features considered and those to be implemented. Confirm energy budget compliance and energy conservation features.

**C-6.1.16 Commissioning.**

Summarize the Commissioning Plan and process to achieve the required commissioning of all commissioned systems. Include the final Commissioning Plan

incorporating comments received. Further clarify the process by which commissioning must be performed.

**C-6.1.17            Transportation and Logistics.**

Summarize the recommendations and analyses (pros and cons), rationale, and scope and cost impacts of the overall Transportation and Logistics Study to include all sub-studies, e.g., Elevator Traffic Analysis and Study, Life-Cycle Cost Analysis for automatic and manual material handling systems, a Waste Management Study, and a Food Service Study (include all food serve areas). The MTLC must also present at the 35 percent design meetings describing how the facility design addresses the transportation, logistics, and waste management requirements of the facility. The Transportation and Logistics Study must be completed at the 35 percent submission.

**C-6.1.18            Wayfinding.**

Summarize the wayfinding master plan recommendations, solutions, and tools for patients, staff, and visitors to navigate in and around a facility. Identify any scope and cost impacts to proposed recommendations, solutions, and tools. Summarize the types of functions and activities a person may perform in a Military Medical Facility.

**C-6.1.19            Food Service.**

If applicable, summarize the food service design. Discuss its parameters and major features to include optimal movement of food products to all designated locations; minimal cross-traffic, backtracking, and queuing conditions; and separation of personnel traffic.

**C-6.1.20            Equipment Specifications.**

Equipment List. The A/E must further refine the initial for-record equipment list into a viable Military Medical Facility room contents list or room-by-room contents listing. Coordinate all categories of equipment for each room identified on the list as well as substitutions or changes with the Using Agency. The type, quantity, and location of biological, radioisotope, fume, canopy, and laminar air hoods must also be indicated in the equipment list. Provide appropriate equipment data and catalog cut sheet(s) for all items of equipment having unique utility requirements, structural support, or space requirements.

Develop requirements for all equipment that does not have current information, as directed by the Design and Construction Agent.

**C-6.1.21            Outline Specifications.**

Provide outline specifications.

**C-6.1.22 Construction Phasing.**

A written narrative must be provided, developed, and documented by the A/E that shows one overall workable phasing plan. This phasing plan must indicate proposed construction duration and describe major elements of the work and any impacts on or by the Government. The phasing plan must include the scope and timing sequence of each identifiable phase or major activity with required precedents, procurement, Government move durations, commissioning, and outfitting. Each phase must be described in terms of the work involved and what work has to come before and after the phase. Phasing elements affecting the Government but not the contractor, such as Government only actions, should be determined and documented.

**C-6.1.23 Addition/Alteration.**

For addition/alteration projects, further identify work activities in a phasing plan that would impact any requirements for continued operation of a facility, including temporary utilities, swing space, implementation of hygienic barriers, and temporary access routing.

**C-6.1.24 35% Design Narrative Record Copy**

The 35% design narrative record copy must be provided to the Design and Construction Agent documenting the outcome of the 35 percent meeting and must be submitted in accordance with the directives established above.

**C-7 35 PERCENT SUBMITTAL DESIGN DRAWINGS.**

35 percent submittal design drawings describing refinement of the 20 percent design requirements must be provided to the Design and Construction Agent in CD electronic format, as well as drawings to be submitted to the Design and Construction Agent in full size format.

**C-7.1 World-Class Checklist.**

Graphically locate all draft World-Class Checklist elements to be provided in specific project documents, i.e., for typical plans, elevations, sections, and details, across all architectural and engineering disciplines.

**C-7.1.1 Civil (Site).**

Show building location, future expansion, existing and proposed structures, topography, final master plan of the site, utilities (include point of origin), utility modifications, roads, parking (surface and structured), and landscaping.

**C-7.1.2 Architectural.**

C7-1.2.1 Floor. For each floor, show all programmed spaces; corridors; structural grid systems (including columns); electrical/communications/mechanical equipment rooms; all vertical and horizontal transportation, e.g., stairs, elevators, escalators,

pneumatic tubes, dumbwaiters; and AGV to meet functional requirements and CONOPS for the building. All spaces identified in the PFD must be labeled with the Room Name and Room Code. Provide programmed and designed net area tabulations. Provide key building dimensions.

C-7.1.2.2 Reflected Ceiling. Show ceiling grid and light fixture placement.

C-7.1.2.3 Exterior Elevations and Major Building Sections. Include all exterior views and multiple cross sections through all unique building areas.

### **C-7.1.3 Interstitial Building System (IBS).**

If approved for project, a conceptual IBS design must be developed, e.g., plans and sections, and that delineates interdisciplinary cross-sections at critical locations.

### **C-7.1.4 Structural.**

Provide drawings of the selected structural system adequately developed so no additional major engineering decisions are required.

### **C-7.1.5 HVAC.**

Show layout of mechanical rooms with all major equipment and one line drawing of distribution systems. Footprints of air handling and other major equipment must be established from catalog dimensional data of three manufacturers. Include clearance space for component cleaning, removal, and maintenance. Distribution mains must be dimensioned. If integral sound attenuating devices are required in VAV/CAV terminal units, indicate these on the project design documents for the respective terminal unit(s).

### **C-7.1.6 Plumbing.**

Show plumbing, medical air, vacuum, medical gas equipment, and major distribution lines. Water supply and gravity drainage mains must be dimensioned. Design all aspects of the piping systems to control thermal expansion and distribution. In the design drawings, include all necessary control features such as location of guides, anchors, expansion ells, offsets, flexible couplings, and other piping features that may affect expansion forces in the piping. For steam and condensate piping, show the required direction, degree of line slope, details of drip traps, and other drainage features.

### **C-7.1.7 Electrical.**

Show placement and location of electrical room layouts, light fixtures, receptacles, motor controls, panelboards, and distribution equipment. Provide single line diagrams of the normal/essential electrical systems, emergency power, and uninterruptible power supply (UPS). Include NFPA 99 risk analysis for wet procedure locations in accordance with Chapter 11 Electrical. Include the grounding system design and initial testing requirements in the project design documents.

#### **C-7.1.8 Communication.**

Show layout of communication equipment, devices, and closets. Provide single line diagrams for each system. Develop, in detail, a Zone Light Activation Matrix (including identification numbers) that must be detailed on the telecommunication systems project design documents. A matrix must be developed for each patient care unit served.

#### **C-7.1.9 Physical Security.**

If ESSs are included in the project design, these systems must be detailed in the project design documents. Include information such as sensor locations, floor plans, riser diagrams, security equipment schedules, monitoring and control equipment, alarm control panels, switches, and access control devices.

#### **C-7.1.10 Fire Protection.**

Show sprinklered areas, fire pumps, stand pipes, fire extinguisher cabinets, and fire alarm systems. Coordinate all design features with applicable criteria and all architecture and engineering disciplines.

#### **C-7.1.11 Life Safety.**

Show sprinklered areas, fire-rated walls and doors, smoke compartments, fire extinguisher cabinets, and fire exits. Show the occupancy classifications and maximum travel distances to smoke and fire barriers.

#### **C-7.1.12 Wayfinding.**

Graphically indicate specific wayfinding locations, proposed solutions, and tools that relates to each of the facility's paths, edges, regions, nodes, and landmarks.

#### **C-7.1.13 Food Service.**

Food service equipment items must be identified in detail in the project design documents and represent the latest available technology. Specific equipment locations, utility requirements including ventilation, and equipment installation must also be shown. Include mounting heights for all wall-hung equipment items.

#### **C-7.1.14 Equipment (to include FFE).**

Show all Categories of equipment. Show all types equipment (to include FFE) on the equipment drawings and floor plans. Clearly identify and differentiate between real property installed equipment (RPIE) and personal property (PP) equipment. Provide JSNs as indicated in the PRC on floor plans, on all Interior Design FF&E sheets, and in tabular format for all applicable logistical categories. Provide separate Architectural equipment plans and Interior Design FF&E plans. Indicate and properly detail the type, quantity, and location of biological, radioisotope, fume, canopy, and laminar air hoods on the drawings. Coordinate all equipment locations and details to ensure adequate utility requirements, structural support, or space requirements are provided.



**C-7.1.15 Structural Interior Design (SID).**

Provide a 35 percent SID package. The SID package must be fully coordinated with all interior and exterior finishes, colors, and materials. Key the room finishes schedule to the plans by room number, room code, and room name, for each room labeled in the PFD. Include proposed SID color scheme/selections. Provide color boards (or binders) with samples of finishes or pictures - scanned pictures are not permitted. An aseptic environment Infection Control Risk Assessment must be coordinated with the SID package to define infection control risks associated within each project. Reference Chapter 6 Architectural, paragraph 6-5.1 for additional details. The wayfinding plan must also be an integral part of the facility's SID package and enhance the design features. The Infection Control Risk Assessment and the wayfinding plan are critical to begin early in the design process. See Glossary for expanded definitions of the SID.

**C-7.1.16 Comprehensive Interior Design (CID)**

Provide a 35 percent CID package for furniture and accessory selection. The CID package must be fully coordinated with all finishes, colors, and materials included in the SID package. Provide CID floor plans, table of all JSNs, and binders with samples of finishes - scanned pictures are not permitted. Provide description and cut sheets for all CID items. Include specific artwork selections. Reference Chapter 6 Architectural, paragraph 6-5.1 for additional details. See Glossary for expanded definitions of the CID.

**C-7.1.17 Construction Phasing.**

Provide a graphic "node" diagram (not a bar chart or time-scaled bar chart) to show the relationships established in the phasing narrative. The graphic representation of the phasing plan in the contract documents should not indicate durations (numerical or graphical) except for the contractually established durations such as Owner moves. Individual phase durations should be considered only in developing the Government's proposed overall contract duration. This phasing plan should not be confused with the requirement to determine the overall constructability and construction timeline that may involve a more detailed milestone chart. The phasing should be coordinated and documented in the design drawings either as a segregated set with all engineering disciplines addressed or have associated drawings within each discipline. A separate overall phasing plan must be developed for the Government's use only to inform, educate, and track Government actions. It should include interaction of Government activities such as move times, swing space durations, and Government outfitting and training activities. This plan must further delineate the coordination of required actions of the Government that are not a part of the contractor's responsibility or contract.

**C-7.1.18 Addition/Alteration Projects.**

For addition/alteration projects, provide 35 percent demolition drawings indicating removal of structural, architectural, MEP, communications systems, and asbestos and other hazardous materials.

**C-7.2 35 Percent Submittal Calculations.**

**C-7.2.1 Calculations.**

Provide conceptual level calculations for all engineering systems being proposed. Include water chemistry test and analysis as per 9-2.4.

**C-7.2.2 Gross and Net Area Tabulations.**

Update all gross and net area tabulations based on refined floor plans.

**C-7.2.3 Sustainability and Energy Performance/Conservation Compliance.**

Provide all supporting calculations.

**C-7.3 35 Percent Submittal Cost Estimates.**

**C-7.3.1 Cost Estimate.**

Update all project costs. Align all revised costs in accordance with the DD Form 1391 format. Provide any changes to the project's DD Form 1391 description, justification, and execution timelines.

**C-7.3.2 Energy Performance/Conservation Compliance.**

Identify energy cost reduction and energy conservation compliance relative to the ANSI/ASHRAE 90.1 baseline. Include return on investment cost calculations and LCC analyses that address all features.

**C-7.4 35 Percent Design Drawing Record Copy.**

The record copy of the 35% design drawing submittal must be provided to the Design and Construction Agent documenting the outcome of the 35 percent meeting, and must be submitted in accordance with the directives established above.

**C-8 65 PERCENT DESIGN SUBMITTAL.**

The Design and Construction Agent must develop the specific submittal requirements to define this level of effort. The project design documents must reflect a 65 percent level of coordination across all architecture, interior design, equipment, and engineering disciplines. Specifications should include a preliminary Division 01.

**C-9 100 PERCENT AND FINAL DESIGN SUBMITTAL.**

The Design and Construction Agent must develop the specific submittal requirements to define this level of effort. When the design is complete, the Design and Construction Agent must submit a complete copy of the final submittal documents, e.g., drawings, specifications, equipment SID & CID packages, cost estimate, instructions to bidders. These documents must be fully coordinated across all architecture and engineering

disciplines within 30 days of completing the 100 percent design documents. This information must be used by facility managers to continue supporting world-class initiatives during construction, transition, outfitting, and O&M of the facility.

**C-10 STATEMENT OF CONDITIONS (SOC).**

If required by the Design and Construction Agent, a completed SOC must be provided at the conclusion of construction by the designer of record.

**C-11 REQUEST FOR PROPOSAL (RFP) FOR DESIGN-BUILD (DB) PROJECTS.**

The RFP for Design/Build (DB) acquisition projects must clearly define all the requirements and background information that a DB contractor must have to estimate, bid, design, and construct the project. These requirements must be included in the RFP as appropriate to the project:

- a. Project Technical Requirements
- b. Updated DD Form 1391
- c. Program for Design (PFD)
- d. Medical Concept of Operations (CONOPS) for the facility
- e. Project Room Contents (PRC)
- f. Requirements for:
  - g. Comprehensive Interior Design (CID)
  - h. Structural Interior Design (SID)
  - i. Additional requirements as determined by the Design and Construction Agent to facilitate fast track construction.
  - j. User needs specific to the design of the facility
- k. Installation approved site location Base Commander signed document.

**C-12 RFP DEVELOPMENT SUBMITTALS.**

These submittals are required during the RFP development:

- a. 5 Percent Level Design Report
- b. Draft RFP (RFP Development). If 20 percent design is provided, include all required submittals in paragraph C-5.3.

- c. Final RFP (RFP Development). If 35 percent design is provided, include all required submittals in paragraph C-6.1.

**C-13 AFTER CONTRACT AWARD.**

Following the successful selection of a DB contractor and award of a DB contract, the DB contractor must provide these comprehensive submittals to include, but not limited to, the following as previously defined:

- a. Final 35 Percent Design Submittal
- b. 65 Percent Design Submittal
- c. 100 Percent Design Submittal

CANCELLED

## APPENDIX D UNIVERSAL X-RAY ROOM

### D-1 GENERAL.

This appendix contains mandatory criteria for Universal X-ray Room design and construction. The Universal X-ray Room is capable of accepting radiographic and fluoroscopic equipment, regardless of manufacturer, with minimal facility modification.

#### D-1.1 Applications.

The Universal X-ray Room applies to Appendix B Architectural and Engineering Design Requirements, Room Codes XDR01 and XDRF1 (reference Figures D-1, D-2 and D-3). The A/E must select an X-ray system for a basis of design based on the JSN provided in the PRC. The designer must design this room to accommodate the selected system and the criteria listed here.

### D-2 SPECIFIC REQUIREMENTS.

#### D-2.1 Electrical Raceway System.

The Electrical Raceway System includes a floor trench, wall ducts, and ceiling cable trays that meet the criteria listed here and additional requirements of the X-ray system selected as a basis of design for installation (reference Figures D-1, D-2 and D-3). All raceways and cable trays must be UL-listed for enclosure of wiring to all X-ray system components and concealed in floors and walls or above the ceiling.

#### D-2.2 Floor Trench.

Floor trench must be bottom-type trench duct, with nominal 3.5-inch by 12-inch duct and a 12-inch-wide by 1/4-inch-thick steel cover plate. Cover plate must be installed flush with the floor with the same tile insert as the floor. Provide a gasket on the cover plate to maintain water tightness. Location of floor trench to the radiology table must be determined by the X-ray system selected for the basis of design.

#### D-2.3 Core Drilling.

Provide oversized conduits below the floor deck in lieu of floor trench when the Universal X-Ray Room is located on a floor other than ground level.

#### D-2.4 Wall Ducts.

Wall ducts are nominal 3.5-inch by 10-inch with 12-inch-wide flush-mounted cover plates finished to match the walls. Transition wall ducts to the floor trench or the conduit below the floor deck.

##### D-2.4.1 Ceiling Cable Trays.

Ceiling cable trays are nominal 3.5-inch by 12-inch with 3-inch load depth National Electrical Manufacturers Association (NEMA) Class 12A ladder type installed above the finished ceiling.

#### **D-2.4.2 Partition Separation.**

Partitions must be provided to separate high- and low-voltage cables in all trenches, ducts, and cable trays.

#### **D-2.5 Electrical Service Requirements.**

Each Universal X-ray Room must have adequate power service to ensure the X-ray system can be installed without additional facility-related electrical work. All feeder conductors must be copper.

##### **D-2.5.1 Power Quality.**

The facility power system must provide the specified nominal voltage (480 V) +/-5 percent to each Universal X-ray Room. Special power conditioning equipment, if required, must be identified and provided with the X-ray system installation.

##### **D-2.5.2 X-Ray Equipment Service.**

Provide 150 ampere, 480Y/277 V, 3-phase (5-wire, neutral, and ground) service to the room. Provide an adjustable trip, 150 ampere, 3-pole, shunt trip circuit breaker in a NEMA 1, flush-mounted enclosure.

##### **D-2.5.3 Emergency Shutdown.**

Provide a large, clearly identified push button to actuate the shunt trip circuit breaker to disconnect all power to the X-ray system.

##### **D-2.5.4 Auxiliary Panelboard.**

Provide a 120/208 V, single-phase, 100 A panelboard with a 50 A shunt trip main breaker to support the single-phase loads in each room. Provide a 20-pole-space panelboard with at least two 20 A, 2-pole circuit breakers, and five 20 A, 1-pole circuit breakers. This panelboard may be served from the nearest general-purpose 120/208 V transformer, or a dedicated step-down transformer fed from the 480 V service to the room. Calculations must be based on 180 A maximum demand if fed from the 480 V service to the room.

##### **D-2.5.5 Voltage Drop and Regulation.**

Total voltage drop in a branch circuit and feeder conductors must not exceed 2 percent from the facility distribution transformer to the Universal X-ray Room. Total voltage regulation of the distribution transformer, feeder, and branch circuit conductors must not exceed 5 percent. For circuits that serve only one room, this calculation must be based on the maximum demand current of the single X-ray generator. For circuits that serve more than one room, this calculation must be based on the maximum demand current of the two largest rooms. Calculations must be based on 180 A minimum demand. Wiring must be sized for maximum 1 percent impedance.

#### **D-2.5.6 Distribution Transformers.**

Distribution transformers must not be dedicated solely to the X-ray system. Voltage regulation is better when an X-ray system is connected to a transformer that is partially loaded with other equipment. X-ray systems must always be connected line-to-line, never line-to-neutral.

#### **D-2.5.7 Essential Power.**

Essential power for X-ray systems, illumination, and duplex receptacles must be in accordance with the Using Agency guidance documents.

### **D-3 WARNING LIGHTS.**

Provide "X-ray In-Use" warning light outside and above patient entry door. The "X-ray In-Use" light must be controlled by applying power to the X-ray system control console. Conduit and wiring from the "X-ray in Use" light to the X-ray unit control console must be provided.

## **D-4 STRUCTURAL REQUIREMENTS.**

### **D-4.1.1 Walls.**

Provide studs on either side of the vertical electrical raceways. Design walls to support 220 pounds vertical-to-horizontal pull. Double walls must be provided between adjacent X-ray rooms. Wall backing and support is required for wall bucky units and control panels.

### **D-4.1.2 Ceiling Support System.**

Provide an overhead tube-mount support system with a load-bearing capacity of 1000 pounds vertical point load and 50 pounds per square foot uniformly distributed load. Ceiling support system to cover the complete ceiling area of the room. Spanning members must be mounted perpendicular to the centerline of the X-ray table and positioned at 25-5/8 inches on center to provide 2 feet of clearance between members. The acoustical ceiling tiles must be suspended from the spanning members. Bottom of spanning members must be flush with the finished ceiling.

### **D-4.1.3 Floors.**

When a floor trench is utilized, provide appropriately thickened slat to accommodate the floor trench.

### **D-4.1.4 Radiology Shielding.**

#### **D-4.1.4.1 At a minimum:**

- a. Radiation shielding must be designed by a health physicist to ensure that the required degree of protection is achieved in compliance with

NCRP Report No. 147. Certify in accordance with NCRP Report No. 102 and the Using Agency qualified expert.

- b. Lead shielding must be 1/16 inch lead or lead equivalent up to 7 feet above the finished floor. Avoid penetrations through the shielding or mitigate penetrations when necessary.
- c. Lead shielding must be applied to the Universal X-ray Room side of the wall partitions and laminated behind gypsum board for protection.

D-4.1.4.2 Use built-in or modular shielding for Operator's Booth and maximize viewing pane(s) where practical.

D-4.1.4.3 All ductwork, grilles, registers, and diffusers must be located above or flush with the ceiling to avoid conflict with overhead equipment rail travel. Thermostat transmission lines must be routed to avoid penetration of shielding.

#### **D-4.2 Fire Protection.**

Automatic sprinkler heads must be recessed.

CANCELLED



Figure D-1 Floor Plan

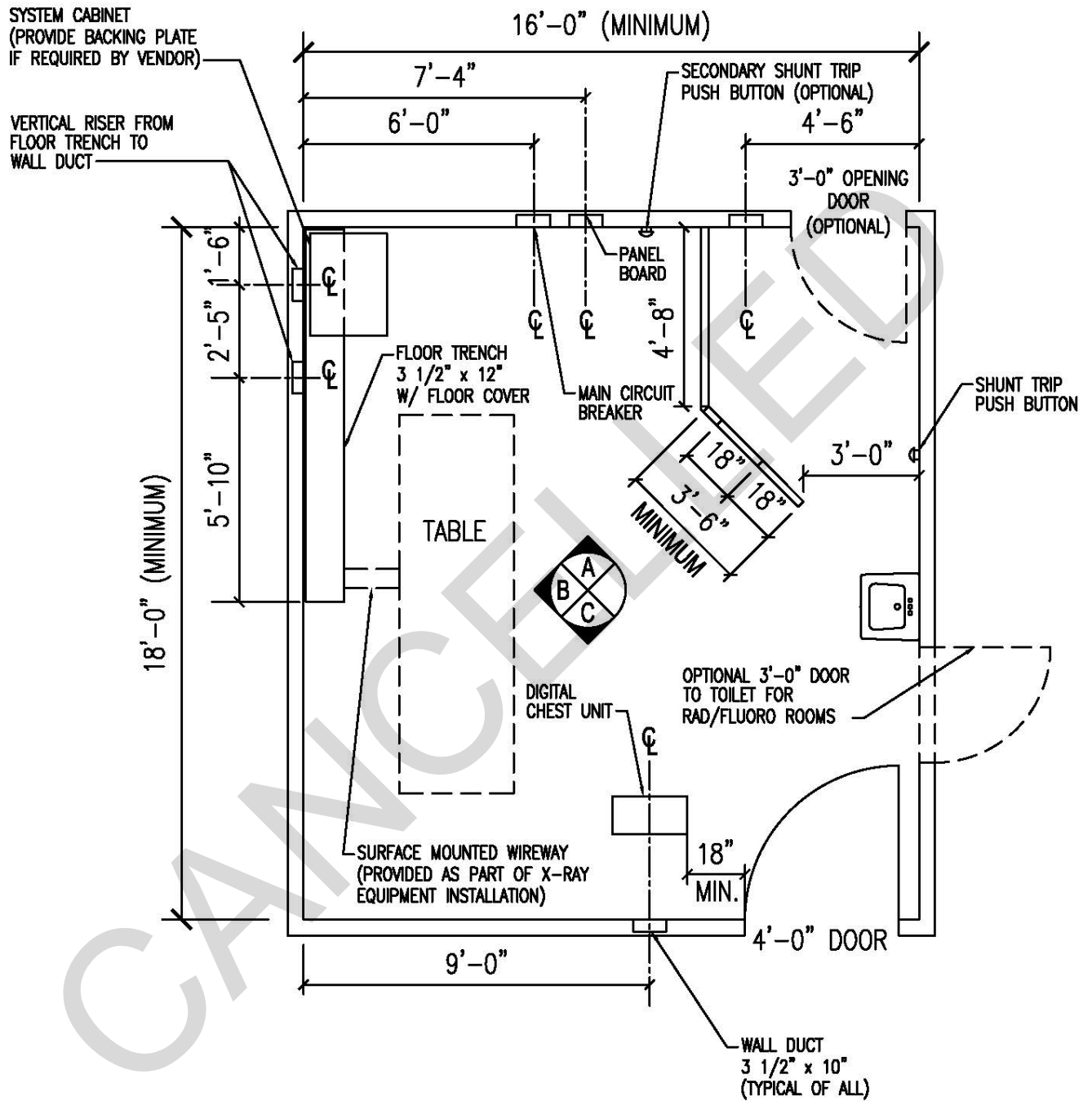

Figure D-2 Above Ceiling Plan

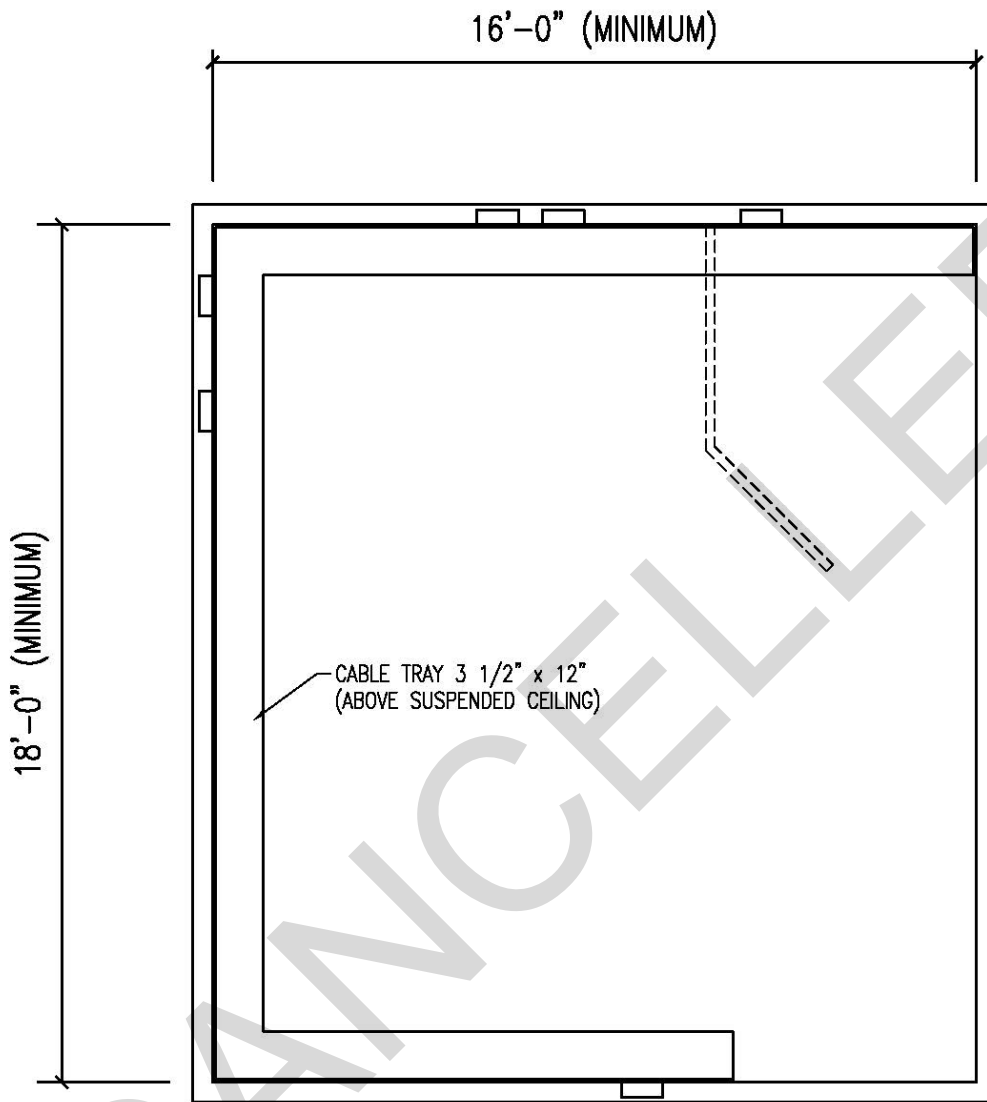
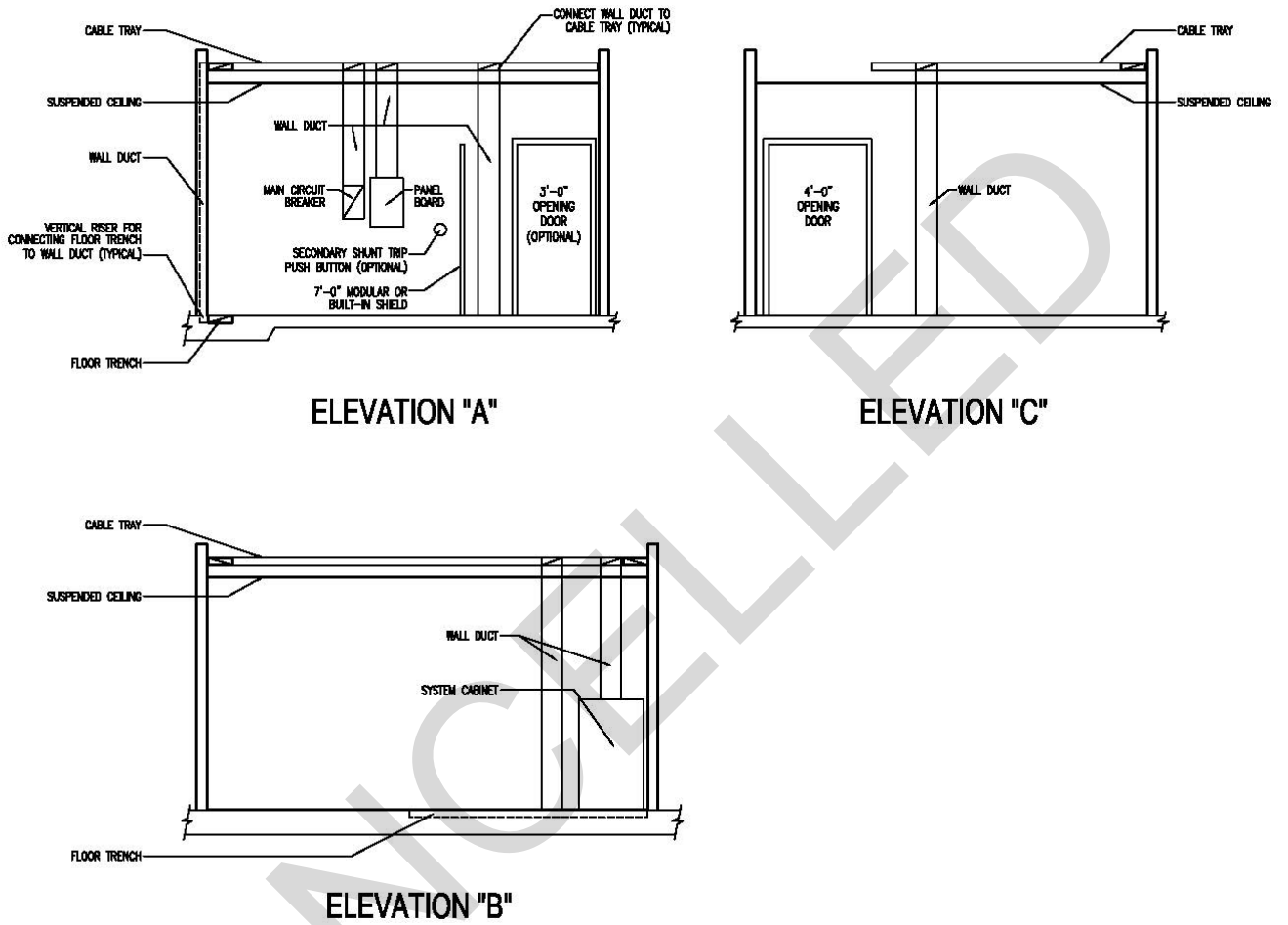

Figure D-3 Elevations



*This Page Intentionally Left Blank*

CANCELLED

## APPENDIX E INTERSTITIAL BUILDING SYSTEM (IBS)

### E-1 GENERAL.

This appendix provides mandatory criteria for the use and application of IBS concepts, including interstitial utility spaces.

### E-2 IBS DESIGN CONCEPT.

The primary concept of interstitial spaces located between functional floor spaces is a non-traditional design feature that permits locating the majority of facility utility distribution and terminal equipment within the interstitial space, and not within functional spaces. This IBS concept offers the DoD several advantages over standard building design in providing convenient installation, maximizing utility access and maintainability, providing for future building flexibility, while minimizing disruption to medical or laboratory services.

#### E-2.1 DoD Systems Module Concept.

The fundamental approach to interstitial building design in DoD is the DoD Systems Module. The DoD Systems Module organizes building areas into discrete modules, normally defined by major medical department or occupancy boundary, and limited to the size of the relevant smoke compartment as permitted by NFPA 101. Each module is served by equipment, e.g., mechanical, electrical, and piping, located in a dedicated utility pod, from which the services are distributed within the confines of the module boundaries via a dedicated distribution zone (interstitial space) and connection zone (above-ceiling space) to the occupied zone (functional space) associated with the respective module. (Refer to Figure E-1.) Having dedicated services for each module, the user has full knowledge of the areas affected by O&M services and by future system modifications. The DoD Systems Module concept also results in greater standardization of major MEP equipment (such as AHUs), reducing the storage of spare parts, and increasing the overall dependability of the systems.

Figure E-1 DoD IBS Systems Module (Typical)

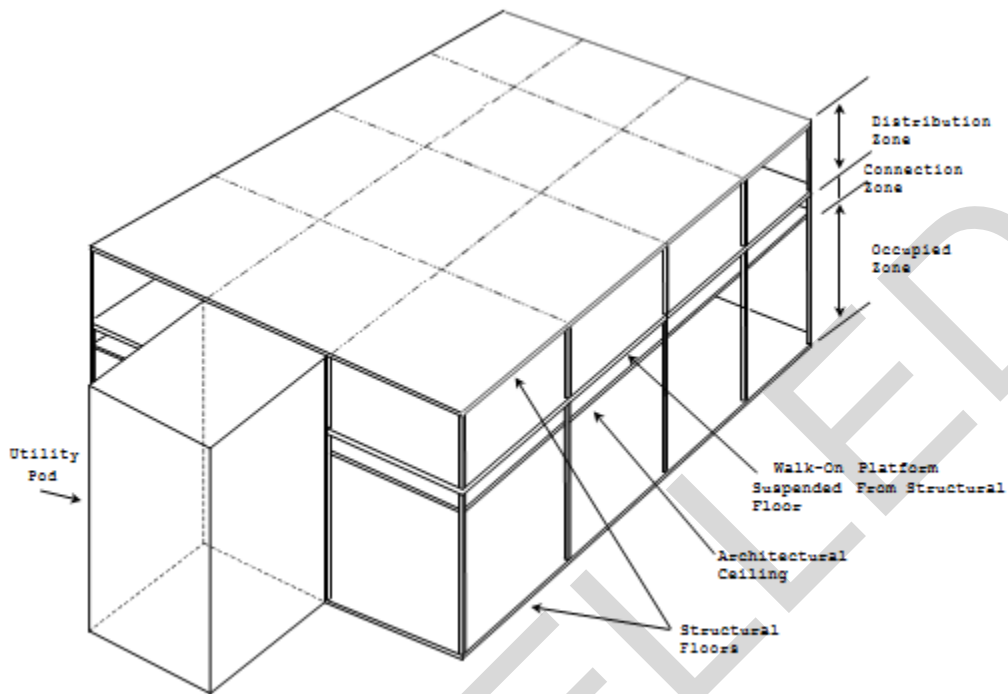

### E-2.2 Alternate Non-Modular Concept.

An alternative, non-modular approach, also with interstitial floors for utility distribution, may in some cases be utilized for some types of DoD facilities. In some instances, the DoD Systems Module design concept can be less economical than a non-modular approach, and is not ideally suited for all building types, e.g., laboratories, in all locations. The non-modular designs typically differ from the DoD Systems Module in permitting equipment, such as AHUs, to serve different (multiple) functional areas, occupancies, or compartments. This can involve horizontal service distribution to differing parts of the building.

### E-2.3 IBS Design Concept Approval.

For any IBS design, most requirements in this appendix including those for construction of the interstitial floor (walk-on platform), utility penetrations, and the organization of the distribution zone for accessibility and fire safety must be incorporated into the design. The decision as to whether an IBS building must follow the DoD Systems Module concept or an alternate non-modular design must be evaluated following the 5 percent design submission and completed by the 20 percent submission by an economic comparison with alternatives. All costs associated with acquisition, operation, maintenance, and alteration for the designated service life of the proposed facility must be included in the comparison. Reference Appendix C Design Submittals and Documentation for submission requirements.

## **E-3 IBS DESIGN.**

### **E-3.1 DoD Systems Module Design.**

The DoD Systems Module, a designated unit of space one story in height, is the basic building block of a DoD Systems Module facility, i.e., the facility is composed of separately identifiable DoD Systems Modules each consisting of a utility pod, a distribution zone, a connection zone, and an occupied zone. Each DoD Systems Module is served by its own utility distribution systems. The relationship of the various zones is illustrated in Figures E-1 and E-2. DoD Systems Modules must not exceed the size permitted by NFPA 101 for the smoke compartment associated with the relevant IBS system module, exclusive of the utility pod. Although there is a spatial discipline associated with the DoD Systems Module, the overall organization and massing of a facility can be varied according to specific project requirements.

#### **E-3.1.1 Utility Pod.**

The utility pod contains AHUs and associated risers, fans, pumps, and other related equipment; electrical and heat exchange equipment; and associated risers serving the DoD Systems Module. Fresh air and exhaust openings are generally part of the utility pod enclosure. The utility pod is the space between two adjacent structural floors or between the highest structural floor and the roof. In multi-story buildings, the utility pods must be stacked from floor to floor so that plumbing and electrical risers can be efficiently and economically accommodated.

#### **E-3.1.2 Distribution Zone.**

The distribution zone is the space between the walk-on platform and the structural floor or roof above. The maximum height of the distribution zone measured from top of walk-on platform to underside of floor slab above must be 9 feet. The distribution zone accommodates the horizontal distribution of main utility systems and provides convenient access to these systems by means of a walk-on platform. Central equipment for mechanical, electrical, plumbing, and communications systems, as well as motorized equipment, is not permitted in the distribution zone. Utility distribution systems enter and leave the utility pod through the distribution zone. The utilities (piping, ducts, VAV boxes, raceways, conduits, and cable trays) must be arranged to minimize future modifications of the mains and to accommodate future modifications of branches and laterals. Except for gravity piping services, most systems in the distribution zone down-feed to the connection zone below. The walk-on platform surface must have a finish, or capability of receiving finish materials, with sufficient bond strength and resistance to abrasion and impact to permit maintenance personnel to walk on the surface without affecting the structural integrity of the platform and without generating a dust problem. Concrete surfaces to be painted must be sealed.

#### **E-3.1.3 Connection Zone.**

The connection zone is the space between the walk-on platform and the architectural ceiling of the occupied zone below. The connection zone accommodates recessed

lighting fixtures, sprinkler piping, and air diffusers and their supports, as well as the horizontal distribution of utilities to individual rooms or spaces. Access to the connection zone must be from the occupied zone, usually through the architectural ceiling.

#### **E-3.1.4 Occupied Zone.**

The occupied zone is the space of functional activity. The occupied zone is defined by the structural floor and the architectural ceiling above.

### **E-3.2 Alternate (Non-DoD) IBS Design.**

#### **E-3.2.1 Use of Mechanical Rooms or Penthouse.**

When utility pods are not provided, AHUs are typically located on the roof (in an enclosed, conditioned penthouse) or on another floor level in a mechanical equipment room. Remotely locating AHUs from the serviced area, compartment, occupancy, or smoke compartment boundary can require vertical distribution of ductwork passing through multiple floors. Also, to reach the intended serviced location, HVAC ductwork may be run horizontally through more than one smoke zone.

#### **E-3.2.2 AHU Serving More Than One Area, Occupancy, or Smoke Zone.**

Where air handling systems are designed to serve multiple areas, occupancies, or compartments, the primary supply and return ductwork must be designed to enter each individual smoke zone boundary at a single point. Provide isolation smoke dampers to allow modifications in that smoke compartment to occur without impact on adjacent compartments. Crossing smoke compartment separation barriers multiple times must require smoke dampers similar to a non-IBS facility.

#### **E-3.2.3 Duct Smoke Dampers.**

Smoke dampers are required in ducts in the distribution zone where a duct serves more than one smoke compartment. Where required, the smoke damper must be located in the duct at the approximate location where the smoke barrier is located below in the occupied zone.

#### **E-3.2.4 Boundary Partitions.**

To manage systems distribution, partitions relative to the boundary of the predominant occupancy are required in the same locations of the distribution zone as located below in the occupied zone. This non-rated partition extends from the surface of the walk-on platform to the underside of the occupied zone above. This partition is required to maintain the separation of the support area relative to the boundaries of only the predominant occupancies, rather than every possible occupancy separation. In addition to utility management, another benefit is the added perimeter wall space for locating additional means of egress paths for the distribution zone.



**E-3.3 General IBS Design Requirements.**

Design requirements for the distribution zone, connection zone, and occupied zone are the same as defined and described for DoD Systems Module designs. Arrangement of IBS elements must be in accordance with Figure E-2.

**Figure E-2 Interstitial Design Elements**

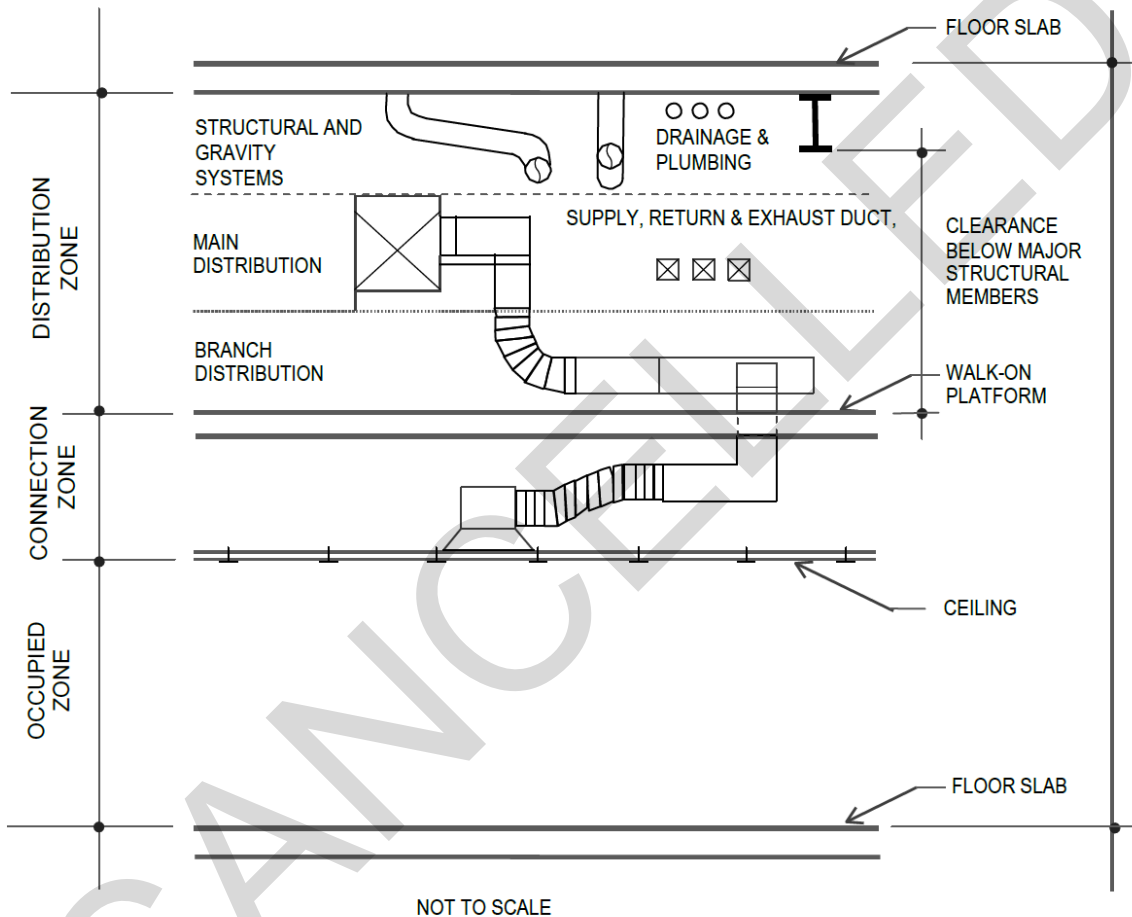

**E-3.3.2 Exceptions.**

As early as possible in the design process, but no later than the 20 percent design submittal, identify any spaces or uses within a facility's proposed design that would either prevent, or otherwise negatively impact, the use of walk-on platforms. Spaces to consider include (but are not limited to) sloped floor areas; high-ceiling spaces, e.g., auditoriums, high-pile storage, and atria; and MRI suites where equipment weight or unusual structural requirements may be applicable.

**E-3.3.3 Number of Stories.**

The walk-on platform constitutes the floor of the distribution zone. A walk-on platform does not constitute an independent story. Each occupied zone and the corresponding

distribution zone are counted together as an independent floor (for the purpose of determining the number of stories).

#### **E-3.3.4 Facility Expansion.**

In DoD Systems Module buildings, placement of utility pods must not encumber vertical or horizontal facility expansion.

#### **E-3.3.5 Existing Facilities.**

When an IBS facility is to be connected to an existing conventional facility, design concerns may arise. Existing floor-to-floor heights are typically less than the heights required for IBS construction. Therefore, it must be necessary to determine which new floors must align with existing floors. Continuity with existing facilities must not be hastily assumed to preclude application of the IBS design concepts.

#### **E-3.3.6 System and Equipment Capacity Increases.**

The designers must recommend which utility systems must be oversized to accommodate future change. AHUs and ducts must be designed to have their capacities increased for future demand growth by a minimum of 15 percent. Other distribution systems may also be designed to accommodate a degree of capacity increase. During initial design, the Design and Construction Agent and the Using Agency must jointly determine the extent of system and equipment capacity increases required.

#### **E-3.3.7 Distribution Zone Accessibility.**

Means of egress paths are provided on the walk-on platform throughout the distribution zone. All means of egress paths accommodate ease of access for maintenance and provide a defined means of egress. The available vertical space clearances within the distribution zone must be sufficient to permit the organization of the utility distribution systems for ease of accessibility. (Refer to Figure E-3.) It may not be practical to arrange the distribution zone for complete accessibility to every component. However, it is important to examine the various accessibility requirements in order to best locate means of egress paths to reach all main systems, feeders, connections, and maintainable equipment. Paths must not be obstructed by utility lines or other equipment. Means of egress paths must provide sufficient clearance for a worker to stand, exclusive of major structural members. Additionally, means of egress paths must have clearly marked walking surfaces that must be maintained free of dust and debris. Access to the distribution zone must be from adjacent stairs and also, in multi-story facilities, from key-operated service elevators designed to stop at the walk-on platform levels. No access to the distribution zone will be permitted through access panels from the connection zone.

Figure E-3 Interstitial Access-Egress (Typical)



**E-3.4 General IBS Mechanical and Plumbing Requirements.**

**E-3.4.1 Riser Locations.**

In DoD Systems Module designs, risers and vertical circulation elements not located in the utility pods must be located at the boundaries of the DoD Systems Modules adjacent to permanent structural elements, stairs, or elevators.

**E-3.4.2 Valves.**

Control valves, except those required to be in the occupied zone such as medical gas control valves, must be located in utility pods or equipment rooms to permit centralized control. Shut-off and balancing valves located in the distribution zone must be tagged and identified on a valve list that shows their distribution zone locations and the areas or equipment served in the occupied zone. Valves must not be located in the connection zone for any utility system unless specifically permitted by the Using Agency.

### **E-3.4.3 Systems Expandability.**

Prime moving equipment, e.g., pumps and fans, must be selected for operation at the midpoint of their operating characteristic curves. Ducts and piping must be sized to permit future flow increases. Stubs, valves, and caps must be provided in plumbing risers and in horizontal branch terminations for future service extensions.

### **E-3.4.4 Air Handling System Selection.**

System selection must be based on functional needs, LCCA, energy efficiency, and ease of maintenance and repair. To enhance maintainability, it is normally desirable to “standardize” the size of AHUs when practical from a performance standpoint. For example, several AHUs of the same unit size and motor horsepower allow economy in the stocking of spare parts. “Off-the-shelf” packaged AHUs must be selected in lieu of custom manufactured units to ensure parts availability and ease of future modification.

### **E-3.4.5 Ventilation of Distribution Zone.**

Under normal conditions, the distribution zone must not require fresh air ventilation. However, if so determined by the designers, ventilation may be required for moisture or temperature control in distribution zones exposed to roofs.

### **E-3.4.6 Gravity Systems in IBS Facilities.**

The location and elevation of sloped gravity piping must be designed to maximize the access around the piping. Gravity systems must not block designated access pathways in the distribution zone.

## **E-3.5 General IBS Electrical and Communications Equipment.**

### **E-3.5.1 Distribution Systems.**

Distribution system routing (horizontal and vertical) and the quantity and location of unit substations must be based on the size of the facility, LCCA, overall flexibility, and long-term system reliability. The benefits of underground (or crawlspace) utility service distribution to the utility pods must be compared with service distribution through the distribution zones considering flexibility, reliability, system maintainability, and safety.

### **E-3.5.2 Electrical Room Locations.**

In all IBS designs, electrical rooms must be stacked to the extent feasible. In DoD Systems Module design facilities, electrical rooms must be located in the utility pods and stacked vertically from floor to floor. Provisions must be made for easily running vertical cabling from floor to floor, i.e., separate/independent conduit risers with pull boxes at each distribution zone. (Refer to Chapter 11 Electrical.) Cabling and wiring must be sized for allowable voltage drop at full design load.

The need for additional electrical rooms, located at opposite ends of the DoD Systems Modules from the utility pods, must be evaluated for maintenance of acceptable voltage

drops, reasonable lengths of secondary cable runs, and numbers of devices per circuit. These additional rooms must be located in the occupied zones adjacent to permanent structural elements, stairs, or elevators, and must also be stacked vertically from floor to floor.

**E-3.5.3 Capacities for Flexibility.**

Capacities of major electrical components, such as main distribution panels and transformers, must be based on the areas served, rather than specific use, to allow for flexibility.

**E-3.5.4 Electrical Secondary Distribution.**

Branch circuiting must be routed through the distribution zone to allow for modification with minimal disruption of the occupied zone. Totally enclosed cable trays must be used to distribute electrical systems wiring. Ground continuity must be provided throughout the cable tray system. Cable trays must be designed with space dedicated in the distribution zone to electrical services for future cable trays.

**E-3.5.5 Communications Systems Distribution.**

Cable trays must be used to distribute communications systems wiring. Ground continuity must be provided throughout the cable tray system.

**E-3.5.6 Identification.**

Coded identification of electrical raceway and junction boxes by voltage and function must be provided at 40-foot intervals and on junction boxes. Circuit identification for electrical wiring and system identification for communications wiring must also be provided.

**E-3.5.7 Lighting.**

Fifty lux (five foot-candles) of lighting must be provided throughout the distribution zone. One hundred fifty lux (15 foot-candles) must be provided over access-egress pathways and at distribution zone elevator lobbies using damage-resistant lighting fixtures. Egress lighting and exit signs must also be provided over access-egress paths and at distribution zone exits as indicated in "Means of Egress Paths" of this appendix. Switches must be provided at each distribution zone entry and exit.

**E-3.5.8 Power.**

Provide specification-grade, heavy-duty, ground fault-protected electrical outlets in the distribution zone for use with portable tools and located to accommodate maximum 50-foot extension cords.

### **E-3.6 General IBS Fire Protection Design.**

Fire protection and life safety features for facilities designed using IBS must be in accordance with the same codes and standards applicable to any non-interstitial facility. The IBS criteria noted here are based upon two special studies conducted by the National Institute of Standards and Technology (NIST)—one in May 1985 (NBSIR 85-3158) and the other in February 1995 (NISTIR 5560). The criteria herein have been coordinated with the requirements of the referenced codes and standards to accommodate the non-traditional characteristics of the interstitial building approach. Proposed designs that vary from the special studies will require a new fire test in accordance with NFPA 251. Note that the use of engineering evaluation in lieu of fire tests is not permitted. Where variations between this standard and other applicable codes and standards occur, the fire safety design requirements for interstitial facilities indicated herein must govern; however, this document must not be applied in such a manner as to exempt NFPA 101 or other applicable code requirements.

#### **E-3.6.1 Occupancy.**

The distribution zone is a “normally unoccupied building service equipment support area” (NUBSESA) as defined by NFPA 101. All IBS distribution zones and interstitial spaces are NUBSESA and must comply with NFPA 101 as modified in this appendix.

#### **E-3.6.2 Smoke Compartmentation.**

In all IBS building designs, smoke barrier separation for smoke compartmentation must be required for occupied and connection zones. Smoke compartmentation is not required for the distribution zone in an interstitial floor.

In DoD Systems Module designs, the integration of facility building modules with NFPA smoke compartmentation requirements is a basic fire protection/life safety principle of this non-traditional building concept. When applying NFPA 101, the modular configuration of the DoD Systems Module approach becomes a significant benefit because compartmentation is a natural byproduct.

#### **E-3.6.3 Floor-to-Floor Fire Separation.**

A two-hour fire separation is required between each functional floor level for IBS facilities. The functional floors are separated by a fire-resistive “floor/ceiling” assembly. The limits of each floor/ceiling assembly are defined by the bottom of the walk-on platform and the top of the structural floor above. In the DoD Systems Module concept, the fire resistance rating runs in a horizontal plane along the utility pod floor, then vertically along the wall separating the utility pod from the occupied zone and connection zone. The fire resistance rating then continues along the walk-on platform to the outside wall. The walk-on platform of the distribution zone must be designed in accordance with NBSIR 85-3158. Figure E-4 illustrates fire protection for the DoD Systems Module concept. The same figure is applicable to alternative non-modular designs, except the Utility Pods are not utilized.

Figure E-4 DoD Systems Module Typical Two Floor Section – Fire Protection

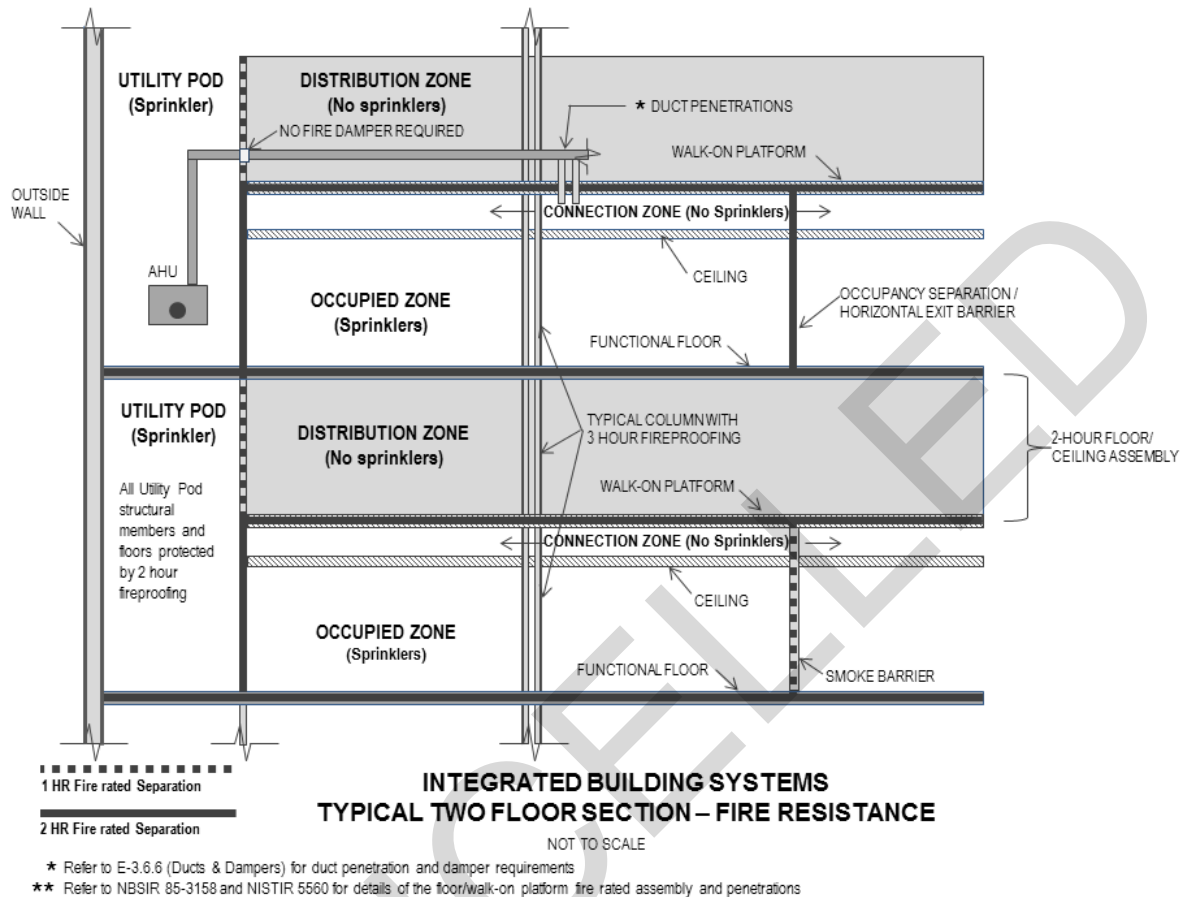

**E-3.6.3.1 Occupied Zone.**

- a. The occupied zone must meet the smoke barrier requirements of NFPA 101.
- b. All barriers and partitions with fire-resistive ratings of two hours or less must pass through the connection zone and terminate at the bottom of the walk-on platform.

**E-3.6.3.2 Distribution Zone.**

- a. Dividing the distribution zone into smoke compartments with smoke barriers is not required.
- b. In DoD Systems Module design facilities, horizontal exit, occupancy separation, or smoke barrier walls located in the occupied/connection zone need not be extended up into the distribution zone.



### **E-3.6.3.3 DoD Systems Module Utility Pods.**

- a. Utility pods must be separated from the distribution zones by one-hour fire-rated construction and from the occupied and connection zones by two-hour fire-resistive construction.
- b. The structural members in the utility pod must have a two-hour fire-resistive rating.
- c. The limits of the connection zone, occupied zone, and the distribution zone must be readily identifiable from the utility pod, particularly with respect to delineation of one- and two-hour fire-rated assemblies.

### **E-3.6.4 Structural Members Fire Protection.**

Results of NBSIR 85-3158 determined that all structural steel within the interstitial space (distribution zone), except the columns, is adequately protected from the effects of fire for a minimum duration of two hours by the walk-on platform/interstitial space arrangement without any fireproofing directly applied to the structural steel within the tested interstitial space. Structural steel within the distribution zone (interstitial space) includes structural members supporting the walk-on platform.

E-3.6.4.1 Provide all columns with three-hour fire-resistive rating within all zones.

E-3.6.4.2 Primary structural members (supporting more than one floor) located within the distribution zone, such as girders and trusses, must have a two-hour fire-resistive rating or be protected in accordance with the fire resistance requirements of the IBC. Secondary structural members (supporting only one floor) within the distribution zone are not required to be fireproofed. Lateral and seismic bracing within the distribution zone need not be fireproofed provided these members do not carry vertical loads (live or dead).

### **E-3.6.5 Openings.**

To prevent fire and smoke migration into the distribution zone, openings through the walk-on platform must be protected as noted here:

E-3.6.5.1 All penetrations, e.g., ducts, pipe, cables, and conduit, must be firestopped at the walk-on platform with approved material in accordance with NBSIR 85-3158 or with an approved through-penetration protection system. All proposed designs with utility penetrations of the walk-on platform must incorporate one of the following methods of firestopping:

- a. Approved firestopping material using materials from the NBSIR 85-3158.
- b. A listed through penetration assembly for the proposed walk-on platform design.



- c. A tested system that complies with ASTM E814 or ANSI/UL 1479 for the proposed walk-on platform.

E-3.6.5.2 Enclose shafts in properly rated construction and tightly sealed for the full perimeter of the penetration at the walk-on platform in accordance with NBSIR 85-3158 or with an approved through-penetration protection system.

### **E-3.6.6 Ducts and Dampers.**

E-3.6.6.1 One-hour Rated Partitions. Fire dampers are not required where ducts penetrate the one-hour fire-rated partition between the utility pod and the distribution zone.

E-3.6.6.2 Two-hour Rated Partitions. Fire dampers are required where ducts penetrate two-hour fire-rated partitions between the utility pod and the occupied and connection zones.

E-3.6.6.3 Walk-on Platform Limitations on Unprotected Penetrations. The total cumulative open space created by unprotected duct penetrations in the walk-on platform above any single smoke compartment or room in the occupied zone must not exceed 0.98 percent of the area of the respective smoke compartment or room. NOTE: this includes annular space between duct and the inside edge of the walk on platform opening. This limit is provided as a design control feature to prevent over penetrating a given area of walk-on platform with un-dampened duct penetrations. The 0.98 percent value is based upon the percentage used in NBSIR 85-3158 and has been coordinated with TJC. Individual duct penetrations must comply with paragraph 0.

E-3.6.6.4 Walk-on Platform Duct Opening Greater than 225 Square Inches. Fire dampers are required for duct penetrations greater than 225 square inches in the walk-on platform. Fire dampers are not required in ducts for openings in the walk-on platform less than or equal to 225 square inches. This includes supply ducts from the distribution zone to the occupied zone, exhaust ducts, and return ducts from the occupied zone to the distribution zone. Flexible, round duct work (UL 181, Class I) is permitted in interstitial space for connections less than 5 feet long and must be no larger than 12 inches in diameter.

### **E-3.6.7 Automatic Sprinkler Protection.**

Approved automatic supervised sprinkler protection as defined by NFPA 101, must be provided throughout the occupied zone and, in DoD Systems Module facilities, in the utility pod. Sprinkler protection is not required throughout the distribution zone or connection zone unless otherwise required by UFC 3-600-01. However, sprinkler protection is required in rooms being used for electrical, communications, and elevator machine equipment, as well as over automatic box conveyor rails and tracks for electric track vehicle systems when located within the distribution zone. Standpipe Protection.

Standpipe protection must be provided in accordance with UFC 3-600-01. In addition, provide hose outlets at each entrance to the distribution zone exit/access door.

### **E-3.6.8 Management of Smoke.**

Each facility must be evaluated on an individual basis for the requirements for a smoke management system. A means for purging the distribution zone of smoke and other products of combustion for post-fire operations must be provided.

### **E-3.6.9 Fire Alarm, Fire Detection, and Mass Notification.**

Fire alarm, fire detection, and mass notification must be provided in accordance with Chapter 14 Fire Protection and Life Safety. In addition, system supervision and alarm zoning must match the fire and smoke compartments associated with the IBS design. Fire alarm and fire detection devices located in the distribution zone must be identified as a subset of the fire alarm evacuation system.

- a. Manual Alarm Initiation. A manual pull station must be provided in the distribution zone at each exit/access door. Zoning for annunciation must be coordinated with the exit enclosure serving the occupied zone exit/access.
- b. Occupant Notification. Alarm notification appliances (speakers) utilizing voice evacuation must be provided for occupant notification throughout the distribution zone. Upon any alarm initiating signal, the alarm notification appliances within the corresponding distribution zone must activate. Provide supplemental visual notification (signaling) in accordance with NFPA 72 along the means of egress paths.
- c. Smoke Detection. Smoke detection is required at each elevator access landing in the distribution zone. The smoke detector(s) must be connected to the elevator controls and provide elevator response per NFPA 101.

### **E-3.6.10 Distribution Zone.**

The distribution zone must not be utilized for any storage.

#### **E-3.6.10.1 Exit/Access.**

Exiting from the distribution zone is provided by a side-hinged swinging door assembly located in each exit stairway enclosure. The exit/access door is the primary means of egress for distribution zone occupants and must meet the exit and ease of operability requirements of NFPA 80 and 101. The leaf of the door assembly must have a minimum width of 36 inches and height of 80 inches. The door must be lockable, self-closing, positive latching, and accessible only by key. Each access door must bear the sign "Storage in This Area is Prohibited by Order of the Fire Marshall." A similar sign must also be placed inside the distribution zone.

### **E-3.6.10.2 Means of Egress Paths**

A designated means of egress path must be provided throughout the distribution zone space in accordance with NFPA 101. Any means of egress path connecting the exit/access doors are required at the perimeter of the distribution zone. Egress travel along means of egress paths must be no more than 100 feet before two separate and distinct means of egress paths of travel to two remote exits are available. Additionally, means of egress paths must be within 25 feet of any portion of the distribution zone where the only available access requires crossing over or under obstructions or distribution equipment. The minimum clear width for all paths is 36 inches, except paths of existing distribution zones must maintain a minimum clear width of 28 inches. Paths must be nominally level with thresholds and elevation changes in accordance with NFPA 101.

- a. Paths must be delineated for the full 36-inch width on the surface of the walk-on platform from the most remote point to the exit/access door. Paths must be painted yellow with direction arrows or cross-hatching indicating direction to each exit/access door. Paths must be treated with a surface sealant prior to painting.
- b. Exit signs must be illuminated and located at each exit/access door. Provide an exit sign adjacent to the doorway within 36 inches of the walk-on platform. Exit signs must also be located along the pathways to provide clear direction toward exits. Exit signs must be in accordance with the size and illumination requirements of NFPA 101.

### **E-3.6.10.3 IBS Headroom Clearance.**

A designated means of egress path must have a minimum headroom clearance of 80 inches and must be maintained along the entire designated pathway, exclusive of interferences from major structural members. Headroom clearance may be reduced to 72 inches for no more than 36 inches along any given path. The minimum spacing between each location with limited headroom clearances must be 36 inches.

### **E-3.6.10.4 Exit Signage and Egress Lighting.**

Exit signage and egress lighting must be on life safety circuits and provided with standby or emergency power, if provided in the facility. Since the distribution zone space is normally unoccupied, separate keyed-alike key-operated light switches (for normal lighting, egress lighting, and exit sign lighting) located at each access doorway must activate normal lighting, egress illumination, and exit sign illumination within the module in accordance with NFPA 70 switch requirements for control of emergency lighting circuits. This must minimize electrical usage and replacement of lamps in the distribution zone.

### **E-3.6.11 Variations.**

In the event a variation from applicable IBS criteria herein is considered, documentation must be provided to justify the need and identify alternate solutions. Solutions may

include equivalent concepts. All documentation must be supported by sound engineering principles that are economically feasible and practical to apply. Variations must be addressed and approved by the Design and Construction Agent prior to incorporation into the design.

Interstitial floor construction characteristics, including the features, properties, and attachment methods of structural support members, walk-on deck materials and properties, and limitations and characterization of allowable deck penetrations, should be in accordance with the referenced NIST-tested assemblies. Where the proposed interstitial design does not replicate NIST tested assemblies, it must be demonstrated to be structurally and thermodynamically equivalent by full-scale testing in accordance with NFPA 251.

### **E-3.7 Documentation and Construction Considerations.**

#### **E-3.7.1 Construction Documentation.**

Drawings for IBS facilities must include plans and sections delineating zones reserved for utility distribution, branches, and laterals. Drawing information must indicate location of all utility system walk-on platform penetrations, and include installation details for each type of utility system penetration. Drawings must be coordinated with all disciplines. Interdisciplinary cross-sections at critical locations, e.g., above ORs, equipment rooms, and corridors, must be provided. Requirements for coordination of all disciplines prior to construction must be included in all pertinent specification sections.

#### **E-3.7.2 Pre-Bid Conferences.**

To ensure that construction contractors take the IBS DoD Systems Module design concepts into account when preparing bids, presentations of these concepts are recommended for pre-bid conferences conducted by the Design and Construction Agent.

#### **E-3.7.3 Pre-Construction Consideration.**

For a DoD Systems Module construction project, a mock-up distribution zone at least 1,000 square feet in area must be constructed at the project site, at the discretion of the Design and Construction Agent. The mock-up must include a complete walk-on platform assembly with suspension members. The sample must also include elements of the utility systems within the distribution zone. Construction of the mock-up must be sufficiently in advance of facility construction to allow time for necessary testing and approval. Various construction details can also be addressed and finalized with the mock-up, i.e., temporary protection of the walk-on platform during construction, proper support and sealing of ducts and fire dampers at walk-on platform penetrations, and permanent fire sealing of the walk-on platform to abutting walls and other permanent structural elements.

**E-3.7.4 Coordination Drawings.**

Coordination drawings must be provided prior to construction that show all utilities and penetrations. This information must be included in the record drawings indicating the as-built conditions.

CANCELLED

CANCELLED

*This Page Intentionally Left Blank*

## APPENDIX F FOOD SERVICE

### F-1 GENERAL.

This Appendix provides criteria and guidance for the design and development of food service systems in new and existing Military Medical Facilities. The Appendix includes lessons learned from Using Agency consultants and Post-Occupancy Evaluations for the purpose of minimizing errors on all future projects.

### F-2 CONSULTING SERVICES.

The A/E of record must provide the services of a qualified hospital food service consultant at project initiation, who must provide design function, flow and equipment input throughout the design process. The consultant must also provide input on the cost estimate of the equipment. A qualified food service consultant is one who has been in business solely as a food facilities design professional for a period of not less than five years and is a member of the Food Service Consultants Society International (FCSI) or equal. The consultant should not be involved in the sale, installation, distribution, manufacture, or representation of food service equipment. Furthermore, the consultant must demonstrate prior experience with Military Medical Facilities that relates to the scope and nature of the project to include locations OCONUS, if applicable.

### F-3 FOOD SERVICE DESIGN OBJECTIVES.

#### F-3.1 Environment.

Provide a functional, efficient, and aesthetically pleasing food and nutrition environment for patients, service members, staff, and guests, within staffing, budgetary guidelines and space requirements. This includes a functional, efficient patient tray assembly area designed to provide room service style patient feeding.

#### F-3.2 Design Elements.

Design dietary facilities that optimize the performance of existing personnel, the facility, and the equipment, while producing high-quality nutrition care products. The design must incorporate EBD elements, such as access to outdoor dining, access to natural views, a variety of spaces for social, dining, and collaborative engagement among patients, family, and staff, and providing positive distractions in all public spaces. Patient tray assembly area must efficiently support room service style patient feeding, please refer to F-4.5. Colocation of all food service spaces and functions on one level should be given the highest priority.

#### F-3.3 Design Flexibility.

Design a food service system with the ability to adapt readily to changing missions, requirements, food preparation processes, labor conditions, and equipment technology.

This objective requires forethought from the Using Agency component, end user, and food service consultant. Recommended methods to build flexibility into the design include planning multiple sources of power with additional electrical capabilities, incorporating dual use equipment, and integrating information technology effectively. The design of the dining area must aim to maximize the projected seating capacity without sharing with non-food service departments, allow for flexibility to accommodate various sized groups as needed within the dining area, and provide a clear flow of traffic into and out of the dining area. The servery, dining area, cash registers and condiments bar must be designed as securable, discrete areas during non-operational hours.

#### **F-3.4 Equipment.**

Provide high-quality food service equipment that is manufactured in the United States (or as designated by regional requirements in OCONUS locations) and sized to accommodate the maximum capacity of the facility at the time of design. Equipment should be dual functional when possible, e.g., a serving line capable of being self-serve or full service. Equipment should be selected and incorporated into the design to create an efficient flow of materials and personnel. Custom-fabricated equipment is permitted in the servery, walk-in refrigeration and freezers, and space-restricted equipment; specified modular equipment must be easily disassembled and reassembled by the end user and must be off of the floor or on wheels or coasters for ease of movement and reconfiguration. Equipment must also be designed and built to promote ease of sanitation and food safety measures.

#### **F-3.5 Energy Efficiency and Sustainability.**

Energy efficiency and sustainability must be considered in the design. The design must incorporate sustainable design features and requirements including day-lighting, energy and water conservation measures, the use of nontoxic materials and finishes, and sustainable O&M practices. The food service design must incorporate space and equipment to maximize waste reduction, reuse, recycling, and composting IAW local Installation requirements. The design must incorporate a blend of reusable dishware and other food service-related disposables.

#### **F-3.6 Food Service Systems.**

Three food service systems—ready prepared, cook/serve, and Grab and Go—or a mix thereof, must constitute the basis of physical planning. Most facilities must likely be a mix of food systems utilizing a conventional flow of food. See the Functional Diagrams depicting flows for the various food service systems in the DoD 510 Food Service Space Planning Criteria.

### **F-4 DESIGN CRITERIA.**

#### **F-4.1 Design.**

Food service design must provide movement of food products to ensure effective monitoring and control of food temperatures through conventional flow while minimizing personnel cross-traffic, backtracking, and queuing conditions. The design also must



incorporate the Food and Drug Administration (FDA) Hazard Analysis and Critical Control Points (HACCP) system, and the Tri-Service Food Code (TSFC) to ensure food safety. The designer of record and food service design consultant must, at the 35 percent submittal, provide schematic plans; circulation paths from servery to seating, loading dock to storage, and kitchen to inpatient units; general material movement; principal dimensions; and dining seating counts in accordance with current DoD 510 Food Service Space Planning Criteria.

#### **F-4.2 Configuration.**

The general configuration of the food service operation must be rectangular to optimize use of space. The capacity to close off and secure the food storage areas, food service preparation, servery area, cash registers and cash control room from the public areas after normal operational serving times must be provided. Configuration must provide an efficient flow of products from storage to preparation, to service in the servery and the patient tray assembly areas. The servery must accommodate large numbers of customers in short periods of time. Utilize a scatter, hollow square, or scramble servery design. Beverage stands should be supplied with water sources and piggyback soda fountain conduit. Serving stations must require extensive planning based on input from the DoD Nutrition Committee, and the local end user, as well as coordination with the DoD 510 Food Service Space Planning Criteria, and Chapter 13 Accessibility Provisions for the Disabled.

#### **F-4.3 Staging.**

The food service storage areas must be collocated with the food service operation. A dedicated food service dock that distinctly separates “dirty” and “clean” receiving must also be provided. The receiving area must provide adequate space and associated utility connections for a large, digital readout platform scale. The food service operations and receiving areas must fully comply with HACCP principles and the TSFC. With respect to food safety, consider staging refrigerators and freezers near the loading dock to minimize elevation in food temperature. Provide a transportation and handling study during the planning stage that addresses the transportation of foods, food products, and food material throughout the Military Medical Facility to include recycling and holding, trash compaction, paths of travel, efficiencies in operations and locations, and waste management associated with food service. Refer to Chapter 16 Transportation and Logistics, for coordinated information related to transportation and waste management requirements. All supply areas where pallet jacks are used must have corridors that are a minimum width of 6 feet, and door design must accommodate pallet jacks with pallets.

#### **F-4.4 Refrigerator and Freezer.**

All refrigerators and freezers must be connected to a single control panel with corresponding temperature readouts. All refrigerators must be fitted with a visual and audio alarm that annunciates in the Food Service Department and in the Facility Management Control Room. All refrigerator systems must be equipped with temperature gauges located outside the entrance of the walk-in unit. Design must

accommodate walk-in access to freezers directly via a walk-in refrigerator for optimal temperature control. Compressors must be located in close proximity to the refrigeration system, in a ventilated room with a floor drain and hose b. Refer to Chapter 10 Heating, Ventilation, and Air Conditioning (HVAC) for ventilation criteria. Compressors must be labeled with the refrigeration unit(s) they service. When using chilled water backup, a redundant pump must be included to avoid refrigeration and freezer compressor damage and food product loss. All refrigeration and freezer units must be placed on an equipment EPS to provide department functionality during periods of crisis. Refer to Chapter 11 Electrical and Appendix B Architectural and Engineering Design Requirements for emergency power requirements.

#### **F-4.5 Patient Tray Assembly.**

Patient Tray Assembly area must be designed to support Patient Room Service. Patient Room Service allows patients to call a dedicated call center that receives patient meal orders. Patients may order meals anytime between established hours (typically between 0600-1800). Meals are prepared and delivered on-demand within a specified time after the patient calls (typically 40 minutes). The Room Service call center must be adjacent to the Patient Tray Assembly area. The Patient Tray Assembly food preparation area must be separate from the dining room food preparation area and must be designed as part of the Patient Tray Assembly area including its own cold preparation/holding area, hot cooking/holding area with appropriate hooded ventilation, tray assembly area and cart staging area. Hot cooking area must have equipment appropriately scaled to support historical patient feeding workload for on demand food preparation such as a griddle (grill), flash oven and stove top. All areas must be designed to include adequate adjoining work space collocated with equipment; for example space to land hot pans, and adequate power, grates, drains, hood systems and exhaust systems.

A directly accessible route from tray assembly to service corridors or elevators to patient care areas is required. Dedicated elevators must be provided to food service in large medical centers. Cart routes must prevent dirty carts from crossing food preparation areas. Patient tray assembly areas must include flexible energy distribution systems. The design must include warmers and refrigeration to ease bulk movement. Beverage islands must be planned and include a water source, ample electricity for expansion, under-floor installation of a 4 inch (minimum size) PVC conduit for "piggy-back" soda fountain conduit and juice machines, steam, and adequate drainage. If beverage dispensers have an ice machine affixed to the top, a minimum ceiling height of 9 feet 0 inches (reference Appendix B Architectural and Engineering Design Requirements) must be planned. The tray line itself should be flexible to decrease or increase the number of trays without changes in infrastructure requirements. Electrical outlet drops from the ceiling must be available to ensure versatility of tray line reconfiguration. Adequate space is required for cart staging, loading, storage, and cleaning.

#### **F-4.6 Dishwashing and Ware Washing.**

F-4.6.1 Design dishwashing and ware washing (pot washing) to prevent crossing workflows between soiled and clean wares, and the food preparation and service areas.

Dishwashing and pot washing must be located adjacent to each other to share labor and equipment. Pot and Pan washing area must be located in proximity to the main food preparation area. Dishwashing space must be designed to provide ample space as dirty dishes arrive on a conveyor system, followed by a disposal system, then a spray mechanism prior to dishes being loaded in the dishwasher. Space to accommodate clean dish air drying and storage, dish racks, pots, plate warmers/low-raiders, inpatient tray racks, and tray delivery carts must be planned. The tray drop-off and dishwashing areas must be located as close to the dining area exit as possible to permit patron self-bussing. Workflow must be designed to prevent garbage and dirty dishes from crossing into clean areas.

F-4.6.2 For manual ware-washing operations, water temperatures for sanitization must comply with the TSFC requirements. In accordance with the TSFC, manual washing must have sufficient space to accommodate air-drying of dish racks, pots, utensils, mobile plate warmers/low-raiders, inpatient tray racks, and tray delivery carts (see DoD 510 Food Service Space Planning criteria). Additionally, after manual cleaning and sanitizing, equipment and utensils must be air-dried or used after adequate draining as specified in 40 CFR 180.940.

F-4.6.3 Install all mechanical ware washers and pot and pan washers with a condensation hood designed to remove hot, moisture-laden air as described in TSFC. For mechanical ware-washing equipment and sanitizing units, the wash solution temperature must comply with the TSFC requirements. Booster heaters must be provided as needed to obtain this temperature requirement. If low temperature ware-washers are used, they must be designed to dispense approved chemical sanitation agents in accordance with Federal, state, and local requirements. The design must include floor drains in the ware washer center where equipment cleaning actually occurs. Special consideration must be given to the coordination of appropriate drain types and their locations. Runs of piping from equipment to drains must be minimized.

#### **F-4.7 Communications.**

Coordinate communications requirements with the MTF and Chapter 12 Communications. Coordinate wiring, conduit, routing devices, and equipment with the Using Agency and Food Service Consultant. Telephone and data lines are required in all offices, the Room Service call center, the tray assembly area, serving lines, storage, receiving, and food preparation areas. Provide connectivity to a wireless network or the internet throughout the kitchen to accommodate capabilities for patient tray ticket transfer and printing, temperature monitoring systems, inventory systems, and communications among staff. Prewiring is required for computerized communication at the cashier stations for electronic payment options and at serving stations for electronic menu boards. The dining area requires a base or post telephone capability for medical staff responses. Prewiring also is required for security systems (Service component coordination), intercom systems, and TV in the dining room. The video surveillance system, at a minimum, must include cameras in the cash control room, at cash registers and in storage and supply areas, and per the requirements of the project specific CONOPS.

#### **F-4.8 Waste Handling.**

Dietary trash and waste handling requirements must be considered in conjunction with the total health facility waste handling requirements to minimize duplication of facilities. (Refer to Chapter 16 Transportation and Logistics.) Dining, food preparation, servery, and processing areas must be designed to avoid transporting trash through food-handling or preparation areas for disposal. Waste pulping disposing systems must be provided to minimize the volume of solid waste products. Current disposal methods for the pulping residue must be accommodated in the design as required per local contract agreement. Recycling areas and equipment must be provided in the Food Service Department for separating and recycling of cardboard, plastics, and other recyclable materials as required per local contract agreement. Handling of waste must be in compliance with local Installation requirements.

#### **F-4.9 Emergency Power.**

Evaluate food service equipment for inclusion on the EPS to ensure impact to food service operations is minimized by loss of power. The cash register electrical power system, at a minimum, must be on UPS; however, evaluation of the cash register system must be part of the overall evaluation of kitchen equipment and may be deemed appropriate for inclusion on the EPS by the Using Agency. Refer to Chapter 11 Electrical and Appendix B Architectural and Engineering Design Requirements for emergency power source requirements.

#### **F-4.10 Steam.**

Steam in direct contact with food must be "clean", containing no amines, oxygen scavengers, or other potentially harmful treatment chemicals. Where treated steam is available, it may be used for the indirect generation of clean steam for cooking. All equipment used in the generation and distribution of clean steam must be constructed of stainless steel in accordance with Chapter 10 Heating, Ventilation and Air Conditioning.

#### **F-4.11 Shelving.**

All storage areas (dry, non-food, refrigerated, and frozen) must be equipped with shelving systems that maximize space utilization and are appropriate to their specific applications. The use of high density or track shelving must be utilized where feasible to expand storage capabilities and maximize available storage areas. Shelving must be finished with galvanized steel, zinc-coated carbon steel, chrome-plated carbon steel, or extruded aluminum. Louvered and open-wire shelving is recommended to encourage air movement. The Chemical Storage Room is best located near the dishwashing and pot-washing area in accordance with applicable safety and environmental requirements.

#### **F-4.12 Plumbing.**

F-4.12.1 Hand washing. All hand-washing sinks must be stainless steel and have "hands free" operation (wrist-, elbow-, or knee-operated). Install in accordance with the

manufacturer's instructions Ensure compliance with the requirements of the TSFC for water temperature, valves and water flow.

F-4.12.2 Floor Drains and Sinks. Provide floor drains or floor sinks at all "wet" equipment (including ice machines) and as required for wet cleaning of floors. Coordinate location of floor drains and floor sinks with equipment to avoid conditions that prohibit removal of drain/floor sink covers (i.e. ensure drain/sink covers can be removed for cleaning).

F-4.12.3 Trough Drains. Provide a floor trough at steam-jacketed kettles and tilt frying pans to facilitate cleaning of food service equipment. Trough grates should be constructed of fiberglass, or heavy gauge stainless steel. Where pallet jacks are utilized, do not provide troughs in front of walk-in refrigerators and freezers. Floors throughout the storage (to include refrigerators and freezers), food preparation, food service and sanitation areas will be graded to eliminate water accumulation.

#### **F-4.13 Compliance Standards.**

Design food services to comply with TJC standards of care of patients, the NSF standards, the TFSC, and the HACCP. Food service equipment must be manufactured or fabricated in accordance with industry standards governing safety such as the NSF, UL, the American Gas Association (AGA), the ASME, and the EPA ENERGY STAR program.

#### **F-4.14 Exhaust Hoods.**

Design all kitchen exhaust hoods to meet ASTM standard for open joints and solid welding, maximum noise thresholds (85 dBA time-weighted average is the maximum allowable exposure), and be self-cleaning. Increased ventilation capability must be considered where deep fat fryers and charbroilers are planned. Refer to Chapter 10 Heating, Ventilation, and Air Conditioning.

#### **F-4.15 Interior Finishes.**

Interior finishes throughout food service must comply with Appendix B Architectural and Engineering Design Requirements. Corner guards, wall guards, and steel kick plates for doors that continue up the wall partitions, toe-kicks, or cabinetry at least four (4) inches, forming a 3/8 inch minimum radius cove as an integral unit must be installed in applicable location per manufactures requirements. Cart wash areas and dish machine areas must be finished for wet environments to include non-slip floors. Acceptable flooring material is durable, light-colored, waterproof, grease-resistant, easily cleanable and can withstand the load of heavy cart traffic. In areas where two contiguous Food Service functions have different flooring finishes in accordance with the Appendix B Architectural and Engineering Design Requirements, provide the finish that is most appropriate throughout the contiguous areas/functions. Grouting should be nonabsorbent and impregnated with epoxy, silicone or polyurethane. Flooring must meet NSF/ANSI 52-2012 minimum standards. Acceptable wall material is durable,

waterproof, grease-resistant and easily cleanable, and can withstand high levels of moisture and the constant movement of carts that will bump and scrape against walls.

**F-4.16 Data Processing Equipment and Security.**

If the facility utilizes an information system or other interdepartmental system, the Food Service operation must be linked to this system (the Hospital Information Management Computer Room). Visual security monitoring systems with data recording and retrieval must be provided in the cash control room where cash counting occurs, the cashier stations, the loading dock, and the corridor utilized to move Food Service supplies into their designated storage areas. The cash control room must be wired for a duress alarm. Reference Chapter 12 Communications, Table 12-3 for further duress alarm requirements.

**F-4.17 Grease Traps.**

Grease traps must be located outside the building. Grease traps must be accessible for cleaning in accordance with Federal, state, and local fire, safety, and environmental requirements.

**F-4.18 Sealants.**

All openings or penetrations of any horizontal or vertical finish surface must be thoroughly sealed so as not to provide hiding places for vermin or encourage the growth of bacteria. Sealant must be water- and detergent-resistant silicone.

**F-4.19 Franchised/Leased Food Services.**

Identification of the type of franchised or leased space for Food Services provided by entities other than DoD Food Service components must be identified during project planning and programming. To minimize unnecessary construction change orders, careful coordination is necessary to identify room net square footages, equipment, engineering requirements, and wireless coverage for government networks to support these distinct functions. These requirements must be submitted to the Design and Construction Agent prior to the 20 percent design submittal.

**F-5 SEISMIC CRITERIA.**

The planning, selection, and installation of food service equipment must be carefully considered with regard to potential damage by earthquakes. Special attention must be given to the mounting of fixed equipment, to utility connections, and to the design features of selected equipment. The required seismic protection must depend on the seismic design level prescribed for individual projects. All bracing details for food service equipment must be indicated on contract documents. Reference Chapter 6 Seismic for additional requirements.

**F-6 FOOD SERVICE EQUIPMENT SPECIFICATIONS.**

All contractor-provided food service equipment items identified on the contract drawing must be specific in detail. The latest technology must be specified. Commercial kitchen appliances must be either ENERGY STAR-qualified or Federal Energy Management Program (FEMP)-recommended. All equipment must meet EPA standards where required, as well as NSF, UL, and AGA.

CANCELLED

CANCELLED

*This Page Intentionally Left Blank*



## APPENDIX G PARKING REQUIREMENTS

### **G-1 GENERAL**

This appendix provides mandatory criteria for parking associated with Military Medical Facilities.

### **G-2 PARKING AUTHORITY.**

DHA/FE is the sole Approving Authority over DoD Military Medical Facilities' parking requirements. Inadequate parking at Military Medical Facilities can impede the MHS' ability to provide prompt and unhindered care to patients. It may also require ill patients to walk extended distances, and potentially increase infectious incidence on public transportation. Parking requirements for Military Medical Facilities within this document and shown in Table G-1 consider these issues, and have been calculated and formulized by professional traffic engineers directly considering patient, staff, and visitor populations at DoD Military Medical Facilities. Military Medical Facility parking requirements at DoD Installations as stated in this document supersede all non-medical state, regional, and or local jurisdiction criteria or requirements.

#### **G-2.1 Facilities and Location.**

The parking area designer must size the required parking area based on calculation as described in this appendix. The designer must consider the minimum use of land, the economical and efficient use of existing and future utilities, ecological conditions, the impact on the environment, sustainability and conservation considerations, maintenance and operations requirements, and the potential need for future growth. Shared parking may be considered where feasible. Landscaping appropriate to the locality should be considered and utilized where applicable, affordable, and practical. Every reasonable and practical effort should be used to integrate existing trees or vegetation into the parking areas.

Parking structures or garages must be considered by DHA/FE when the site is too small to accommodate the required parking, when the value of the land is excessive, the site is located in a harsh climate, the required amount of spaces creates extreme walking distances, or sustainability or ecological issues prevail. Parking structures must be included as a separate line item in the project CIDM and later project DD Forms 1391. DHA/FE must approve parking structures on a case-by-case basis.

**Table G-1 Required Parking Spaces for Military Medical Facilities**

<b>Calculating the Required Parking Spaces for Military Medical Facilities</b>	
Number of Parking Spaces Required = $(.75)(X_1) + (.40)(X_2) + (X_3) + (X_4)$	
Where:	<p><math>X_1</math> = All personnel working in the Military Medical Facility on a full-time basis, plus an allowance for visitors and part-time staff. Include FTE's, contract maintenance, Red Cross volunteers, base exchange, clergy, interns, technical school trainees, Veterans Affairs and other Using Agency liaison staff, Reserve, Guard, Professional Military Exchange (PME), and visitors. Visitors include: Installation Commander, TRICARE, RMO Security, Fire Department consultants, salespersons, and shift change overlap. (Use 10 percent if statistics are unavailable for additional visitors, shift overlap, and part-time staff.)</p>
	<p><math>X_2</math> = For hospitals, clinics and dental facilities, use projected M2 (Military Medical business objects database) outpatient visits for the peak month (typically either August or September) and peak day of the week (typically a Monday). Include projected M2 pharmacy encounters: new scripts ("FCC" and "FCD") and refills except those scripts that are picked up at satellite pharmacies.</p>
	<p><math>X_3</math> = One space for each inpatient bed.</p>
	<p><math>X_4</math> = One space for each organizational Government vehicle, and MTF contractor support vehicle that regularly uses the MTF parking facilities. For those vehicles that are too large to use a standard parking space, provide an oversized space.</p>
Notes:	
1. Additional parking spaces must be justified.	
2. "Reserved" spaces for Command, General Officers, Rewards, and Disabled are included in the above factors.	
3. Spaces for Disabled are included in the above total and must be allocated in accordance with Chapter 13 Accessibility Provisions for the Disabled for both inpatient and outpatient requirements as applicable.	
4. Calculations adjustments may be made to the $X_1$ parking requirement for carpooling, public transportation (if reliable and available within reasonable walking distance) and for Quarters/Housing (if within reasonable walking distance). The adjustment must only be based on those staff that routinely avoids using the MTF parking facilities.	
5. Parking lot segregation for staff, patients, and visitors must be addressed by Using Agency during design.	

## APPENDIX H GLOSSARY

### H-1 ACRONYMS

A	ampere(s)
A/E	Architect/Engineer Firm
ABA	Architectural Barriers Act
AC	Alternating current
ACGIH	American Conference of Governmental Industrial Hygienists
ACI	American Concrete Institute
ADT	Admissions-Discharge-Transfer
AFCEC	Air Force Civil Engineer Center
AGA	American Gas Association
AGV	Automatic guided vehicle
AHA	American Hospital Association
AHRI	Air-Conditioning, Heating, and Refrigeration Institute
AHU	Air handling unit
AIA	American Institute of Architects
AICUZ	Air Installations Compatible Use Zones
AISI	American Iron and Steel Institute
AMR	Autonomous Mobile Robot
ANSI	American National Standards Institute
APFSS	Automatic Primary Feeder Selector Switch
APL	Approved Product List
ASCE	American Society of Civil Engineers
ASHRAE	American Society of Heating, Refrigerating and Air-Conditioning Engineers
ASME	American Society of Mechanical Engineers

ASTM	American Society of Testing and Materials
AT/FP	Antiterrorism/Force Protection
ATS	Automatic transfer switch
AV	Audio visual
BDF	Building distribution frame
BFE	Base Flood Elevation
BGSF	Building Gross Square Feet
BIM	Building Information Modeling
BOD	Beneficial occupancy date
BP/IS	Bypass/isolation switch
BSC	Biological Safety Cabinets
Btuh	British thermal unit per hour
BUMED	U.S. Navy Bureau of Medicine and Surgery
C	Celsius
CATCODE	Category Code
CATV	Cable television
CAV	Constant Air Volume
CCT	Correlated color temperature
CCTV	Closed-circuit television
CCU	Cardiac Care Unit
CDC	Centers for Disease Control and Prevention
CEHNC-EDX	U.S. Army Corps of Engineers Medical Facilities Mandatory Center of Expertise and Standardization, Huntsville Engineering and Support Center
CFCI	Contractor furnished and contractor installed
CFM	Cubic foot per minute
CFR	Code of Federal Regulations

CGA	Compressed Gas Association
CHAPI	Chase Helicopter Approach Path Indicator
CID	Comprehensive Interior Design
CIDM	Capital Investment Decision Model
CIDM-PG	Capital Investment Decision Model Process Guide
CIP	Capital Investment Proposal
CMS	Central Material Service
CO2	Carbon dioxide
CONOPS	Concept of Operations
CONUS	Contiguous United States
CPD	Central Processing and Distribution
CWE	Current Working Estimate
CxC	Commissioning Specialist for the Construction Phase
CxD	Commissioning Specialist for the Design Phase
CxG	Commissioning Specialist for the Government
DA	Design Authorization, or dental compressed air
DALT	Duct Air Leak Testing
dB	Decibel
DB	Design-Build, or dry bulb
DBB	Design-Bid-Build
dBmV	Decibel (referenced to millivolt)
DC	Direct current
DDA	Design Directive Amount
DDC	Direct digital control
DFE	Design Flood Elevation
DGSF	Departmental Gross Square Feet

DHA	Defense Health Agency
DHA/FE	Defense Health Agency/ Facilities Enterprise
DHP	Defense Health Program
DIN	Deutsche Industrie Normen
DISA	Defense Information Systems Agency
DISS	Diameter Index Safety System
DMLSS	Defense Medical Logistics Standard Support
DoD	U.S. Department of Defense
DoDM	U.S. Department of Defense Medical
DSV	Dental surgical vacuum
DTR	Dental Treatment Room
DUF	DTR Usage Factor
DX	Direct Expansion
EA	Economic Analysis
EBD	Evidence-Based Design
ECEv	The Environment of Care-Europe, Version V
ECG	Electrocardiogram (also EKG)
EEG	Electroencephalography, electroencephalogram
EENT	Eye, ear, nose, and throat
EIA	Electronic Industries Alliance
EMG	Electromyography
EMI	Electromagnetic interference
EMS	Emergency Medical Service
EN	European Norm
ENT	Ear, Nose, and Throat
EO	Executive Order

EPA	U.S. Environmental Protection Agency
EPS	Emergency Power System
ER	Emergency Room
ESS	Electronic Security System
ETL	Engineering Technical Letter
ETSA	Elevator Traffic Study and Analysis
EWD	Engineering Weather Data
F	Fahrenheit
FACP	Fire Alarm Control Panel
FAR	Federal Acquisition Regulation
FDA	Food and Drug Administration
FDMF	Fiber Main Distribution Frame
FEMA	Federal Emergency Management Agency
FLCM	Facilities Life Cycle Management
FO	Fiber optic
FPT	Functional Performance Test
FRG	Federal Republic of Germany
FSES	Fire Safety Evaluation System
FTE	Full-Time Equivalent.
FY	Fiscal year
GFCI	Ground-Fault Circuit Interrupter, or Government furnished, contractor installed
GFGI	Government furnished, Government installed
gpg	grain(s) per gallon
GPM	Gallon(s) per minute
GPS	Global positioning system

GSF	Gross square footage/feet
GSM	Gross square meters
HACCP	Hazard Analysis and Critical Control Points
HAG	Historical Analysis Generator
HCRA	Healthcare Service Requirements Analysis
HDMI	High-definition multimedia interface
HDTV	High-definition television
HEPA	High-efficiency particulate air
HID	High intensity discharge
HIS	Hospital Information System
hp	horsepower
HQ	Headquarters
HVAC	Heating, ventilation, and air conditioning
HW	Hazardous Waste
Hz	Hertz
I/O	Input and output
IA	Instrument air
IBC	International Building Code
IBS	Interstitial Building System
ICU	Intensive Care Unit
ID	Identification
IDS	Intrusion Detection System
IEEE	Institute of Electrical and Electronics Engineers
IMD-IA	Information Management Department Information Assurance
in-Hg	inches of mercury
IPC	International Plumbing Code



IRES	Intrafacility Radio Reinforcement System
ITV	Interactive Television
JITC	Joint Interoperability Testing Committee
JSN	Joint Schedule Number
KHz	Kilohertz
kPa	kilopascal(s)
kV	kilovolt(s)
kVA	kilovoltampere(s)
L&D	Labor and Delivery
L/s	Liter(s) per second
LA	Laboratory Air
LAN	Local area network
LCC	Life-cycle cost
LCCA	Life-cycle cost analysis
LCD	Liquid crystal display
LDE	Laboratory dust evacuation
LDR	Labor, delivery, and recovery
LDRP	Labor, delivery, recovery, and postpartum
LED	Light-emitting diode
LOD	Level of detail/development
LPM	Liter(s) per minute
LS	Life Safety
LSA	Life Safety Assessment
LUF	Laboratory Usage Factor
MA	Medical compressed air
MCWB	Mean coincident wet bulb

MDI	Medical Design Instructions
MEP	Mechanical, electrical, and plumbing
MFDO	Medical Facilities Design Office
MHS	Military Health System
MILCON	Military Construction
MINC	Multimedia Interactive Network Center
Mips	micro inch per second
MMA	Material Management Analysis
MRI	Magnetic resonance imaging
MRT	Modified Rhyme Test
MTLC	Medical Transport and Logistics Consultant
MTF	Medical Treatment Facilities or Military Medical Facilities
MV	Medical surgical vacuum
N	Nitrogen
NAVFAC	Naval Facilities Engineering Command
NC	Nurse Call, or noise coefficient
NCAV	Nurse Call Audio Visual
NCPC	National Capital Planning Commission
NCR	National Capital Region
NCRP	National Council of Radiation Protection and Measurements
NCTV	Nurse Call Tone Visual
NEC	Network Enterprise Center
NEMA	National Electrical Manufacturers Association
NEPA	National Environmental Policy Act
NFPA	National Fire Protection Association
NICU	Neonatal Intensive Care Unit

NIOSH	National Institute for Occupational Safety and Health
NIST	National Institute of Standards and Technology
NO	Nitrous Oxide
NRC	Nuclear Regulatory Commission
NSF	Net Square Feet
NTP	Normal temperature and pressure
NTS	Network Time Synchronization
O	Oxygen
O&M	Operations and maintenance
OASD(HA)	Office of the Assistant Secretary of Defense (Health Affairs)
OCONUS	Outside the Contiguous United States
OE	Oral evacuation
OMB	Office of Management and Budget, Executive Office of the President
OPR	Owner's Project Requirements or Office of Primary Responsibility
OR	Operating room
OSHA	Occupational Safety and Health Administration
PA	Process Air or Program Amount
PACU	Post-Anesthesia Care Unit
PAPD	Public address and program distribution
PC	Personal computer
P.E.	Professional Engineer
PF	Power factor
PFC	Pre-Functional Checklists
PFD	Program for Design
PoE	Power over Ethernet
PRC	Project Room Contents

psf	Pounds per square foot
PSI	pounds per square inch
psig	pound-force per square inch gauge
PT	Physical therapy
PTS	Pneumatic tube system
PTZ	Pan/tilt/zoom
PVC	Polyvinyl chloride
QA	Quality Assurance
QC	Quality Control
RA	Requirements Analysis
RF	Radio frequency
RFI	Radio frequency interference
RFP	Request for Proposal
RH	Relative humidity
RMF	Risk Management Framework
RMS	Root mean square
RMW	Regulated Medical Waste
RP	Radio Paging
RTA	Ready to Advertise
SATV	Satellite television
SCFM	Standard cubic feet per minute
SEPS	Space and Equipment Planning System
SID	Structural Interior Design
SOC	Statement of Condition
SOFA	Status of Forces Agreement
SOW	Statement of Work or Scope of Work

SPL	Sound pressure level
SRA	Safety Risk Assessment
SRM	Sustainment, Restoration, and Modernization
STC	Sound Transmission Class
SUF	System Usage Factor
TAB	Test and Balance
TBCx	Total Building Commissioning
TIA	Telecommunications Industry Association
TIS	Telecommunications Infrastructure System
TJC	The Joint Commission
TLA	Transportation Logistics Analysis
TR	Telecommunication Room
TSS	Telephone Switching System
TV	Television
UFC	Unified Facilities Criteria
UHF	Ultra-high frequency
UMCS	Utility Monitoring and Control System
UPS	Uninterruptible power supply
USACE	United States Army Corps of Engineers
U.S.C.	United States Code
USGBC	United States Green Building Council
UTP	Unshielded twisted pair
UV	Ultraviolet
V	Volt
VA	U.S. Department of Veterans Affairs
VAV	Variable air volume

VE	Value Engineering
VMC	Visual meteorological condition
VoIP	Voice over Internet Protocol
W	watt(s)
WAGD	Waste anesthesia gas disposal
WAN	Wide Area Network
WAP	Wireless access point
WB	White Board
WMA	Waste Management Analysis

CANCELLED

## H-2 DEFINITION OF TERMS

For additional terminology, please reference the following:

DoD 6015.1-M, *Glossary of Healthcare Terminology*, January 1999, Assistant Secretary of Defense For Health Affairs, TRICARE Management Activity.

*NFPA Glossary of Terms*, 2008 National Fire Protection Association, [www.nfpa.org](http://www.nfpa.org)

---

**Air Handling Unit (AHU).** An air conditioning unit consisting of fan(s), coil(s), filter(s), and other components designed and sized for supplying conditioned air to a given area or space(s).

**Ambulatory.** Able to walk; not confined to bed.

**Ambulatory Healthcare Center.** A facility, with FAC code of 5501, capable of providing four or more simultaneous outpatients surgical procedures and other medical treatment, not requiring extensive patient convalescence or overnight observation.

**Anesthesia.** Partial or complete loss of sensation, with or without consciousness, as a result of drug, disease, or injury.

**Anesthetic.** Applies to any inhalation agent used to produce relative analgesia or general anesthesia.

**Anesthetizing Location.** Any area of the facility that has been designated to be used for the administration of any flammable or nonflammable inhalation anesthetic agents in the course of examination or treatment including the use of such agents for relative analgesia.

**Antiseptic.** The prevention of decay, putrefaction, or sepsis through use of an agent that must prevent or arrest the development of microorganisms.

**Apparatus.** Furniture, laboratory hoods, centrifuges, refrigerators, and commercial or man-made onsite equipment used in a laboratory.

**Architect and Engineer (A/E) Firm.** A business composed of professional architects and engineers.

**Asbestos.** A natural mined mineral that is a good thermal insulator, a good acoustical insulator, fire resistant, resistant to friction and wear, and a poor conductor of electricity. Known to cause lung cancer, mesothelioma, and other forms of cancer in the stomach and colon.

**Aseptic Environment.** An environment or area that is intended to be free from pathogenic microorganisms to prevent infection.

**Automatic Box Conveyor (ABC).** Also known as Electric Track Vehicle (ETV) or Powered Track Tote Box Conveyor System (PMTCS). A rail system utilizing self-

contained buss bars to provide power to special carriers that contain and move small supply, demand, and other items between stations on the track network.

**Automated Data Processing (ADP).** Any equipment that is used in the automatic acquisition, storage, manipulation, management, movement, control, display, switching, interchange, transmission, or reception of data information.

**Automatic Data Processing Equipment (ADPE).** General purpose, commercially available automatic data processing equipment, and the systems created by them.

**Autoclave.** An apparatus for sterilizing utilizing steam under pressure.

**Automated Guided Vehicle System (AGVS).** Also known as Driverless Vehicle System (DVS). This system utilizes a battery-powered, electronically-controlled vehicle that follows a predetermined route (guide path or track that is buried in the floor or adhered to its surface) to move carts and material throughout the facility. The system utilizes the guide path network and special elevators to make the horizontal and vertical routings. Different degrees of automation and capabilities are available. The basic system components commonly found in a hospital application include: driverless vehicles, elevators, carts (modules), guide path and controls, cart wash(s), and battery charge equipment.

**Average Interval.** The elapsed time in seconds between elevator departures from a terminal floor averaged over a specific time period. Average interval is a measure of the “quality” of elevator service. Average interval can be measured in existing buildings but must be calculated for new buildings. For practical purposes, it can also be viewed as the average roundtrip time of an elevator, divided by the number of elevators within the group in question. Average interval is not a direct measure of how long prospective passengers wait for service.

**Average Maximum Ride Time (AMRT).** The amount of time a passenger is in an elevator from the point of origin to the destination is referred to as the “ride time.”

**Average System Response Time.** The average time it takes for hall calls to be answered by an arriving elevator car. This is an estimated or simulated factor for new facilities but can be measured for existing facilities.

**Average Waiting Time.** The average period that users wait for elevator service. This is an estimated or simulated factor. For example, if one person arrives at a lobby and initiates a hall call, and waits for 20 seconds for the car to arrive, while a second person arrives at the same time as the car, the average for these two persons being served is 10 seconds (20 seconds plus 0 seconds divided by 2). Tests indicate that average passenger waiting time (AWT) for service at a typical intermediate floor approximates 65–80 percent of the average interval during heavy two-way traffic periods.

**Backflow Prevention.** The use of a recognized device to prevent the backflow of water or other liquids, mixtures, or substances into the distributing pipes of the potable supply of water from any source such as a plumbing fixture or mechanical equipment.



**Base Isolation.** This is a seismic construction element to prevent ground motion from being transmitted from the building foundation into the superstructure.

**Basic Life Safety (Seismic).** A seismic damage risk classification category and an operational level category. Facilities in this category meet the minimum requirements and objectives of seismic building codes—to provide a collapse-resistant structure and thereby save lives. The life safety of the immediate building occupants is the sole objective of this category. Efforts to control damage due to earthquake in this category are minimum and limited primarily to the saving of human life. Reference Chapter 8 Seismic.

**Beneficial Occupancy Date (BOD).** The date on which a facility is available to serve the mission for which it is constructed.

**Built-in Equipment.** That equipment that is affixed to the facility and usually included in the construction contract.

**Bulk Nitrous Oxide System.** An assembly of equipment as described in the definition of bulk oxygen system that has a storage capacity of more than 3,200 pounds, approximately 28,000 cubic feet (normal temperature and pressure [NTP]) of nitrous oxide.

**Bulk Oxygen System.** An assembly of equipment such as oxygen storage containers, pressure regulators, pressure relief devices, vaporizers, manifolds, and interconnecting piping that has a storage capacity of more than 20,000 cubic feet of oxygen (normal temperature and pressure [NTP]) including unconnected reserves on-hand at the site. The bulk oxygen system terminates at the point where oxygen at service pressure first enters the supply line. The oxygen containers may be stationary or movable, and the oxygen may be stored as gas or liquid.

**C-Arm.** Term referring to a specific type of radiographic machine used for fluoroscopic examinations.

**Cardio.** Related to the heart.

**Cart (also called a “Module”).** A wheeled vehicle upon which material is placed to transport it throughout the facility. Many cart variations are available. The movement of carts can be accomplished by employees, or semi-automated or automated transportation systems as determined by careful analysis for each individual hospital.

**Cart Lift.** A small vertical lift that is dedicated to the movement of carts. Cart lifts are usually automated and provide automatic dispatch and loading and unloading of carts. “Cart lifts” that are manually dispatched and require manual loading and unloading of carts are generally called “cart dumbwaiters.”

**Cart Wash.** The semi- or fully-automated machine that washes and rinses carts as required by the individual hospital’s program. Units may provide automated or manual loading and unloading. Units may or may not provide a full drying capability. Selection of the correct unit(s) for an application should be made after a complete analysis of all requirements, to include financial (life-cycle cost [LCC]) and traffic. When the cart wash

function is to be done manually, it is done by hose or steam gun in an equipment washroom or area.

**Category Code (real property).** A series of numerical codes used to classify and categorize real property. These code numbers are based on ten basic functional classes coded by the DoD. They are generally a five-digit code to plan, program, budget, design and construct, inventory and maintain its facilities. Some commands add digits to refine the functional description. A category code may consist of a collection of attributes that come together to form the specific category code

**Category Code (NFPA).** The terms “Risk Category”, “System Category” and “Space Category” are used throughout NFPA 99 and can be confusing as the definitions appear similar and all have a range of 1 to 4 with category 1 being the highest risk (or most stringent requirement) and category 4 being the lowest risk (or least stringent requirement). Space categories relate to the typical function in a given space and are defined by NFPA 99 paragraph 3.3.127, and for the Military Health System, are provided with the room code in Appendix B Architectural and Engineering Design Requirements. Risk categories are defined by NFPA 99 paragraph 3.3.146 and are determined by a risk assessment IAW NFPA 99 paragraph 4.2.1. System Categories are the resultant design criteria to be applied to a given system after considering the Risk Category and Space Category, but note that there is not always a direct correlation between these categories.

**Central Material Service (CMS).** The physical area and functional operation that is responsible for cleaning, sterilizing, preparing, packaging, storing, and distributing sterile items within the facility. CMS is the primary support element for the Operating suites and Labor and Delivery Rooms.

**Central Processing and Distribution (CPD).** An all-inclusive term for that function in a hospital that encompasses those terms variously known as Central Supply, Central Nursing Supply, Central Sterile Supply, and Central Material Services. Generally refers to a materials handling methodology. Provides for the central management of all medical material required to support patient care activities. The heart of this concept is an automatic distribution system. CPD requires the standardization and centralization of the elements of storage and distribution.

**Civilian Health and Medical Program for the Uniformed Services (CHAMPUS).** An indemnity-like program called TRICARE standard that is available as an option under DoD’s TRICARE program. There are deductibles and cost shares for care delivered by civilian healthcare providers to active duty family members, retirees and their family members, certain survivors of deceased members, and certain former spouses of members of the seven Uniformed Services of the United States.

**Code of Federal Regulations (CFR).** The CFR annual edition is the codification of the general and permanent rules published in the Federal Register by the departments and agencies of the Federal Government. It is divided into 50 titles that represent broad areas subject to Federal regulation. The 50 subject matter titles contain one or more individual volumes, which are updated once each calendar year, on a staggered basis. The annual update cycle is as follows: titles 1–16 are revised as of January 1, titles 17–

27 are revised as of April 1, titles 28–41 are revised as of July 1, and titles 42–50 are revised as of October 1. Each title is divided into chapters, which usually bear the name of the issuing agency. Each chapter is further subdivided into parts that cover specific regulatory areas. Large parts may be subdivided into subparts. All parts are organized in sections, and most citations to the CFR refer to material at the section level.

**Commission of Fine Arts (CFA).** A regulatory body in the U.S. National Capital Region (NCR) that helps determine applicability of all Federal Military Construction (MILCON)-funded facilities within the NCR. Reference National Capital Planning Commission [NCPC].

**Compaction.** A waste-handling methodology whereby the volume of waste materials is reduced for ease of disposal.

**Concepts.** The first phase of design that includes Block Plans (S1), Schematics (S2), Design Development (S3), and the final 35 percent submission (S4). The basis on which a Programmed Amount (PA) can be set for the Budget Submission. Approximately 35 percent of the design effort, as opposed to the second phase of design that is called the “working drawings” phase of design.

**Constructability.** An analytical study that reviews the methodology, ease (or difficulty) with which a project can be administered, bid, built, enforced, understood, and phased that determines degrees of difficulty and construction time required to build a Medical Treatment Facility. Reference Chapter 3 Design.

**Construction Contract Solicitation.** The point in the design-construction process when all review comments from the 100 percent design submittal have been incorporated, the Current Working Estimate (CWE) is within the Project Amount, DHA/FE has notified the Design and Construction Agent that funds are available, and DHA/FE has notified the Design and Construction Agent to advertise the project for bids. It is generally the point in the process when the project ceases to be a design effort and becomes a “Construction Project.”

**Construction Management Plan (CMP).** Establishes processes and procedures for the execution of the construction contract.

**Contingency Medical Treatment Facility (CMTF).** An entity within the Services’ wartime organization structure that provides medical care during the contingency, war, or national emergency. CMTFs include Medical Treatment Facilities (MTFs) afloat, deployable medical systems (DEPMEDS), and organizational medical assets.

**Contract Documents (CDs).** Design drawings and specifications that, as a unit, constitute the basis for receiving bids and awarding a contract for construction. Contract documents are the basis on which a building is constructed.

**Cost-Benefit Analysis (CBA).** The process of assessing all pertinent costs and benefits, usually performed in terms of an expected life-cycle of the system.

**Court, Enclosed.** A court bounded on all sides by the exterior walls of a building, or exterior walls and lot lines on which walls are permitted.

**Criteria.** Military Unified Facilities Criteria (UFCs), criteria manuals, guide specifications, definitive designs, Using Agency guidance, standard designs, and other related guidance published to promote quality facilities' engineering, design, construction, and maintenance.

**Critical Facility.** Critical Facility provides selective protection for critical healthcare mission staff and functions following catastrophic Chemical, Biological, Radiological, Nuclear, and High-Yield Explosive (CBRNE) attacks.

**Critical Path.** The linear path through a work schedule network determining the shortest time within which all work can be completed.

**Current Working Estimate (CWE).** The current cost of the project including construction cost, contingency, and supervision inspection and overhead (SIOH). Required at certain levels of effort of design to compare against programmed amount (PA) to determine whether the project is executable given projected funds availability.

**Damage Risk Classification Categories (Seismic).** Three seismic categories that attempt to relate the seriousness of the consequences of damage due to earthquake. The selection of a category may consider the density of human occupancy, the importance of the activity, or the value of the contents or structure itself. These categories are as follows: Basic Life Safety, High Risk Facility, and Essential Facility. Reference Chapter 8 Seismic.

**Dedicated Elevators or Lifts.** A vertical transportation element that must be restricted in use to a singular predefined function, i.e., clean surgical material only, or soiled material only.

**Defense Health Agency/Facilities Enterprise (DHA/FE).** The office of primary responsibility for all DoD MILCON funded facilities. <https://home.facilities.health.mil/>.

**Dental Compressed Air (DCA).** Compressed air system used for drying applications during dental procedures and as a power or drive source for lifts, locks, and pneumatic dental instruments and equipment. Not used for breathing or respiratory support of any kind. Reference Chapter 9 Plumbing and Medical Gases.

**Dental Surgical Vacuum (DSV).** Dry vacuum system used to support patient care in dental treatment rooms and oral surgeries. Refer to Chapter 9 Plumbing and Medical Gases.

**Dental Low Vacuum for Oral Evacuation (OE).** Low vacuum, high volume, wet pipe system to provide scavenging, collection, and disposal of liquids, solids, and aerosols from dental procedures. Refer to Chapter 9 Plumbing and Medical Gases.

**Departmental Gross Area.** The functional space within a department plus intra-departmental circulation. Does not include "general" circulation.

**Design and Construction Agent.** The agency designated by the Secretary of Defense (SECDEF) responsible geographically (or by agreement) for the design or construction execution associated with the military construction program. Responsible for the project

during design, construction, warranty period and financial closeout. Current Design and Construction Agents are:

- a. The U.S. Army Corps of Engineers (USACE)
- b. The Naval Facilities Engineering Command (NAVFAC)
- c. The Air Force Civil Engineer Center (AFCEC) in the United Kingdom

**Design Authorization (DA).** Notices from DHA/FE to the Design and Construction Agents to proceed with A/E selection and award, design a project to varying levels of effort, advertise, and ultimately award a construction contract. Usually designates project, project fiscal year, project location, programmed amount (PA), scope of the project (size in square feet), which meetings DHA/FE will attend, any deviations from the submittal requirements in this document, and whether or not DHA/FE wishes to participate in the A/E selection process. Reference Chapter 3 Pre-design.

**Design Energy Target (DET).** An energy-use performance target for a facility, not to include process loads. Reference Chapter 4 Sustainable Design Principles.

**Design Energy Use (DEU).** A calculation of the estimated energy consumption of a facility, not to include process loads. Reference Chapter 4 Sustainable Design Principles.

**Designated Seismic Systems.** The seismic force-resisting system in all structures and those architectural, electrical, and mechanical systems or their components in RC III and IV structures that require design in accordance with Chapter 13 of ASCE 7 and for which the component importance factor,  $I_p$ , is greater than 1.0. This designation applies to system that are required to be operational following the Design Earthquake for RC III and IV structures and follow the MCER for RC V structures. All system in RC V facilities designated as MC-1 (see Chapter 4 of UFC 3-310-04) must be considered part of the Designated Seismic Systems. Designated Seismic Systems will be identified in Chapter 6 of this UFC and will have an Importance Factor  $I_p = 1.5$ .

**Disabled Person.** An individual who has a physical or behavioral condition that, to a material degree, limits, contributes to limiting, or if not corrected will probably result in limiting the individual's performance or activities to the extent of constituting a substantial physical, behavioral, or vocational handicap.

**Drug Dispensing.** The issuance of one or more doses of prescribed medication in containers that are correctly labeled to indicate the name of the patient, the contents of the container, and all other vital information needed to facilitate correct patient usage and drug administration.

**Dumbwaiter.** A small vertical lift that is dedicated to the movement of carts, tote boxes, and other similarly-sized items. Generally, this term implies manual loading and unloading of the cargo.

**Economic Analysis (EA).** A cost-benefit analysis done to identify the relative cost-effectiveness of delivering healthcare to a projected beneficiary population under

different MTF sizing scenarios. P.L. 97-337 (15 October 1982), amended by Section 1087 of Title 10, U.S.C., requires an EA be done to determine the space to be programmed in MTFs for military retirees and their dependents.

**Electrical Life Support Equipment.** Electrically powered equipment whose continuous operation is necessary to maintain a patient's life.

**Elevator Population.** The people (and other users) affecting the elevators in question.

**Etiologic Waste.** Any viable microorganism or its toxins that causes or may cause human disease.

**Evaluation.** Implies an analysis to be performed by the designer (A/E) in the basic contract (as opposed to "studies" or "investigations," that are extra services to be performed to complete the contract intent and requirements).

**Evidence-Based Design (EBD).** The conscientious, explicit, and judicious use of current best evidence in making planning and design decisions that advance the needs of patients, staff, families, and organizations. Reference Chapter 6 Architectural.

**Facilities.** Building(s), equipment, and supplies necessary for the implementation of services by personnel.

**Facilities Sustainment.** Facilities sustainment provides resources for maintenance and repair activities necessary to keep a typical inventory of facilities in good working order over the specific facility's expected service life.

**Facility.** A separate individual building, structure, utility system, or other item of real property improvement each item of which is subject to separate reporting and recording in accordance with DoD Instruction 4165.14, Real Property Inventory and Forecasting.

**Federal Energy Management Program (FEMP).** The U.S. Department of Energy (DOE) Federal Energy Management Program (FEMP) provides services, tools, and expertise to Federal agencies to help them achieve their legislated and executive-ordered energy, greenhouse gas, and water goals. These are delivered through project, technical, and program services.

**Federal Information Processing (FIP).** Any automatic data processing (ADP) equipment procured with Federal Government funds.

**Fenestration.** The arrangement of windows in a building, their size, placing, style, etc.

**Fire Protection Engineer.** A person, persons, or firm specializing in building fire protection design who (that) is qualified to interpret and design fire protection drawings and specifications in accordance with NFPA, JCAHO, UBC, and other regulatory requirements.

**Fire Safety Evaluation System (FSSES).** In accordance with NFPA 101M.

**Fire Watch.** A person or persons assigned to an area for the purpose of protecting.

**Fixed.** Fastened to walls, floors, or ceiling or to steam, gas, plumbing, electrical power, or sensor lines in a permanent manner.

**Flammable Storage Cabinet.** A cabinet for the storage of flammable and combustible liquids constructed in accordance with NFPA 30, Flammable and Combustible Liquids Code.

**Floor Area, Gross.** Gross floor area must be the total floor area within the building to include all rooms, mechanical rooms, hallways, stairs, closets, thickness of interior or exterior walls, columns, or other features. Where the term “area” is used, it must be understood to be gross area unless otherwise specified. Reference Chapter 3 Design and Figure 3-1 for expanded explanation.

**Floor Area, Net.** Net floor area must be the actual occupied area in a functional space, not including thickness of walls, chases, columns, or general circulation. Reference Chapter 3 Design and Figure 3-2 for expanded explanation.

**Functional Requirements.** Those requirements necessary to ensure a particular facility continually meets the objective of the function for which it was constructed.

**Grade.** The degree or inclination of slope at ground level.

**Gravity Chutes.** Usually used for the vertical return of trash and linen (separate chutes) to a holding and collection room at the base of each chute.

**Green Board.** Moisture resistant gypsum board.

**Handling Capacity, Elevator.** The “quantity” measure of elevator service is called handling capacity. Handling capacity is the number of persons and vehicles that can be transported by the elevator system in a given length of time. Average interval and handling capacity must be measured or calculated for the same designated time period to be meaningful.

**Hazardous Area in Laboratories.** The area inside fume hoods or enclosures where tests or procedures are being conducted.

**Health.** A condition in which all functions of the body and mind are “normal” and active.

**Healthcare Occupancies.** Reference NFPA 101 for occupancy definitions.

**Hematology.** The science of the blood.

**High Efficiency Particulate Air (HEPA) Filter.** Replaceable filters having a minimum collective efficiency of 99.97 percent for 0.3 micron particle. Reference Appendix B Architectural and Engineering Design Requirements.

**High Hazard Areas.** Areas of structure, buildings, or parts thereof used for purposes that involve highly combustible, highly flammable, or explosive products or materials that are likely to burn with extreme rapidity, or that may produce poisonous fumes or gases, including highly toxic or noxious alkalis, acids, or other liquids or chemicals that involve flame, fume, explosive, poisonous, or irritant hazards; also uses that cause

division of material into fine particles or dust subject to explosion or spontaneous combustion, and uses that constitute a high fire hazard because of the form, character, or volume of the material used.

**High Risk Facilities (Seismic).** A seismic damage risk classification category. Facilities in this category are recognized as warranting a higher level of damage risk than the average building but less than for an essential facility. Efforts to control damage due to earthquake in this category are intermediate. Reference Chapter 8 Seismic.

**Histology.** Study of the microscopic structure of tissue.

**Hospital Bed.** A bed for an adult or child patient. Bassinets for newborns in maternity units, beds in labor rooms, recovery rooms, and other beds used exclusively for emergency purposes are not included in this definition.

**Illuminated, Externally.** An illumination source contained outside the device that is to be illuminated.

**Illuminated, Internally.** An illumination source contained inside the device that is to be illuminated.

**Incineration.** In waste handling, the act of burning pathological and other designated waste/infectious waste in an incinerator in order to render the waste material(s) harmless.

**Inspection Certificate.** An identification applied on a product by an approved agency containing the name of the manufacturer, the function and performance characteristics of the product, and the name and identification of an approved agency indicating that the product or material has been inspected and evaluated by an approved agency

**Interdepartmental Circulation.** General circulation. Circulation that provides access to and from various departments; included elevators, stairs, and major corridors.

**Interstitial Building System (IBS).** System involving coordinated design of all elements to achieve a building of optimum functionality, appearance, maintainability, and adaptability. Reference Appendix E Interstitial Building Systems.

**Interstitial Space.** Unfinished and unoccupied space between floors used for horizontal utility distribution systems, of sufficient size to accommodate workmen, and that permit maintenance and alteration without interruption of activities on the floors. Reference E Interstitial Building Systems.

**Intradepartmental Circulation.** The area reserved for corridors and passages that are found immediately within the departmental area.

**Japanese Facilities Improvement Program (JFIP).** A government of Japan initiative, which started in 1979 to ease the financial burden of stationing U.S. Forces in Japan. The program reduces U.S. Government cost to improve the quality of life and military posture. Approximately 21 percent of the government of Japan host nation support provided to the U.S. Forces in Japan is allocated to JFIP.



**Joint Schedule Number (JSN).** The number used to identify equipment on architectural drawings and plans supporting Military Construction (MILCON) projects.

**kvp.** Unit used to describe the radiation quality of X-rays. X-rays generated by electrons accelerated in a potential difference of, e.g., 100 kilovolts (kV), are termed 100 kvp (kV peak voltage) X-rays.

**Laboratory Air (LA).** Compressed air system for use in medical or dental laboratories. May be combined with a dental compressed air (DA) system. Reference Chapter 9 Plumbing and Medical Gases.

**Life-Cycle Cost (LCC).** Reference UFC 1-200-02.

**Life-Cycle Cost Analysis (LCCA).** Reference UFC 1-200-02.

**Local Area Network (LAN).** A modular communication methodology whereby the facility is prewired during construction for current and future communications needs, i.e., telephone, Composite Healthcare (computer) Systems (CHCS), without having to surface-mount additional wires or coax in the future and thereby reduce future communication installation costs.

**Logistics Elevator.** An elevator whose primary purpose is to transportation various supplies, i.e., dietary or medical/surgical supplies, devices, and equipment, as well as occasional construction materials.

**Material Handling (MH).** The function of moving, packaging, and storing of substances in any form. Material handling does not alter, change, enhance, or add value to a product in any way. It is a “cost” function only that should be minimized to the greatest extent possible (within given aseptic, physical, operational, and functional parameters).

**Materials Management (MM).** Material management is a scientific technique, concerned with planning, organizing, and control of flow of materials, from their initial purchase to destination.

**May.** “May” is used to indicate provisions that are used at the option of the designer.

**Mechanical Space.** The area that houses the primary and intermediate components of the air conditioning, plumbing, communication, electrical, and ventilation systems. This area includes chases and shafts as well as mechanical and electrical equipment rooms.

**Medical Compressed Air (MCA).** Compressed air system used only for medical functions requiring breathable air to support respiration or for air-driven instruments that discharge into the pharynx. Reference Chapter 9 Plumbing and Medical Gases.

**Medical Military Construction (MILCON) Program.** That portion of the President’s budget devoted exclusively to the renovation, upgrade, and replacement of Medical Treatment Facilities (MTFs) that cost more than \$750,000. MILCON is not supposed to include Operations and Maintenance (O&M) or Repair and Maintenance (R&M) unless the area that could be done with O&M or R&M is affected by the larger MILCON project and must be accomplished to provide a complete and usable facility in accordance with NFPA and JCAHO requirements.

**Medical Surgical Vacuum (MV) System.** Dry vacuum system used only for medical functions involving patient care, therapy, and diagnostic functions. May be used for Dental Surgical Vacuum (DSV) requirements in dental treatment rooms and oral surgeries. Reference Chapter 9 Plumbing and Medical Gases.

**Migration.** When more than one elevator group is available in a building, a passenger's origin does not necessarily dictate which elevator group will be used. A certain percentage of the population will migrate to other areas of a building to use an elevator for reasons such as meeting a friend or dropping off something on the way to their destination. This percentage is usually estimated to be 5-10 percent of the population (or as otherwise appropriate for the facility being studied).

**Military Construction (MILCON) Programming.** The annual processing, review, and approval of MILCON project proposals by the Military Department Secretaries, the OSD, and the OMB for submission to Congress.

**Milliampere (mA).** The unit of electrical current flow equal to 0.001 ampere.

**Mixed Occupancies.** Reference NFPA 101 for occupancy definitions.

**Modernization.** Alteration, repair, remodeling, replacement, and renovation of existing buildings (including initial equipment thereof) and replacement of obsolete, built-in equipment of existing buildings. Does not include replacement of a facility or a portion to a capacity greater than the capacity of the existing facility.

**Modular.**

- a. Having commensurable dimensions.
- b. Capable of arrangement with exact fit in more than one sequence or direction.
- c. Composed of or containing predetermined dimensional or functional units such as repetitive structural bays or service modules.

**National Capital Planning Commission (NCPC).** A regulatory body in the U.S. National Capital Region (NCR) that helps determine applicability of all Federal MILCON-funded facilities within the U.S National Capital Region. (See definitions of Commission of Fine Arts and NCR.)

**National Fire Codes.** Codes published by the National Fire Protection Association (NFPA).

**National Stock Number (NSN).** Medical equipment identification consisting of an applicable four-digit class code number plus the nine-digit national item identification number.

**Noise Criteria-Level (NC-Level).** Refers to a set of contours roughly corresponding to the ear's response to sound pressure level at various frequencies that define the background sound level existing within a space.

**Nonflammable Anesthetizing Location.** Any anesthetizing location designated for the exclusive use of nonflammable anesthetizing agents.

**Nonflammable Medical Gas System.** A system of piped oxygen, nitrous oxide, compressed air, or other nonflammable medical gases.

**Non-Regulated Medical Waste (NRMW).** Waste not classified as regulated medical waste (RMW), recyclable materials, or hazardous materials. Poses no special danger of infection or injury to personnel or the public.

**Nurses' Stations.** Areas intended to provide a center of nursing activity for a group of nurses serving bed patients where the patient calls are received, nurses are dispatched, nurses' notes written, inpatient charts prepared, and medications prepared for distribution to patients. Where such activities are carried on in more than one location within a nursing unit, all such separate areas are considered a part of the nurses' station.

**Operational Level Category (Seismic).** These categories define the post-earthquake performance requirements for various facilities with respect to operational mission, disaster preparedness, and medical post-earthquake needs.

**Operationally Ready Mode.** A critical facility that completed its functional checks and determined to be capable of transforming to a higher level of preparedness. Ready for the next higher Operational Mode.

**Operations and Maintenance (O&M) Funds.** Those funds other than MILCON used for the express purpose of upgrading and maintaining existing facilities and equipment, or for the purchase of government furnished equipment and furnishing (not built-in) to provide a complete and usable facility at BOD.

**Passenger Elevator.** An elevator configured to move visitors, staff, and other ambulatory pedestrian traffic between floors. This elevator is generally wide and shallow in configuration to facilitate the movement of pedestrians.

**Patient Service Elevator.** An elevator configured to move patients on beds and gurneys, as well as patient care-related equipment such as portable X-rays, inhalation equipment, empty gurneys, wheelchairs, etc. The elevation is generally narrow and deep to facilitate the loading and unloading of this traffic.

**Permanent.** For the purposes of Medical Military Construction (MILCON), any structure designed for a useful lifespan of 25 years or longer.

**Planning and Design (P&D) Funds.** Funds for costs associated with preparation of design plans and specifications (A/E and in-house design costs) and costs to develop Operation and Maintenance Support Information (OMSI) products for a specific project.

**Plumbing Fixture.** An installed receptacle, device, or appliance that is supplied with water or that receives liquid or liquid-borne wastes and discharges such wastes into drainage systems to which it may be directly or indirectly connected.

**Pneumatic Tube System (PTS).** A pneumatically-powered, small diameter (usually 4 or 6 inches) tube that moves special carriers that contain messages, small supplies, or other items that physically “fit” and can tolerate this method of transport. These systems can be point-to-point or multi-station in design.

**Post-Occupancy Evaluation (POE).** An evaluation of the design and construction of a facility performed after BOD to obtain lessons learned that can be applied to present and future designs and criteria.

**Precious Metals Recovery Program.** Promotes the economical recovery of precious metals from excess and surplus material, and the use of recovered precious metals as Government Furnished Material.

**Pre-Engineered Building (PEB).** For the purpose of these criteria, pre-engineered buildings are considered as those buildings in various configurations and sizes that are available from manufacturers as a standard item. This type of construction may be used for DoD medical and dental facilities where such use is indicated by life-cycle cost to be economical, where they will meet the performance and functional requirements of the project, and are architecturally compatible with the environment in which they will be erected. Because of the great variance in the quality and cost of such structures on the market, extreme care must be used in selection to ensure that the quality of the facility to be provided is commensurate with the project requirement and expected longevity of the mission to be served.

**Process Air (PA).** Compressed air system to support functions such as medical service columns or shop operations. Reference Chapter 9 Plumbing and Medical Gases.

**Program Amount (PA).** The initial PA is the estimated cost of a facility based on the DoD Cost Guidance and DD Form 1391 preparation prior to any design effort that establishes a project’s viability in the budget cycle. Once Concept Design is completed, the PA may be adjusted (up or down) based on the developed and validated Current Working Estimate (CWE) from the Design and Construction Agents. This PA (new) may be the amount sent to Congress and the basis of Final Contract Document Design phases through Construction Contract Solicitation.

**Program Objective Memorandum (POM).** Formal document to identify major initiatives, their resource consumption estimates, and their operational justification used to prioritize and allocate manpower and fiscal resources.

**Rad/Fluoro.** Radiographic/Fluoroscopic.

**Radio Frequency Interference (RFI).** Electromagnetic radiation that is emitted by electrical circuits carrying rapidly changing signals, as a by-product of their normal operation, and which causes unwanted signals (interference or noise) to be induced in other circuits.

**Readiness, Military.** The ability of forces, units, weapons systems, or equipment to perform as they were intended and to deploy and employ without unacceptable delays.

**Regulated Medical Waste (RMW).** Waste that poses danger of disease transmission and/or objectionable appearances to personnel and the public.

**Request for Proposal (RFP).** A procurement document released to commercial industries outlining a requirement for development or implementation of a system or design. Industry provides its formal response in the form of proposed solutions to the problem defined, its cost and development schedules, and other pertinent data upon which the Government selects a vendor(s) with whom to contract.

**Respiratory Care Department/Service.** An organizational unit of the hospital that is designed for the provision of ventilator support and associated services to patients.

**Root Mean Squared (RMS).** Also known as Effective Value. The value of alternating current or voltage equal to 0.707 times its peak value.

**Schematic Design.** Room-by-room scaled drawings defining the size and arrangement of areas in a building or building configuration as a basis for design development.

**Section 2807, Title 10, U.S.C.** The appropriate committees of Congress must be notified of the intent to award a contract for A/E services and construction design for the proposed Military Construction (MILCON) project if the estimated cost of such services exceeds \$1,000,000. This notification must include the scope of the proposed project and the estimated cost of such services and must be made not less than 14 days before the initial obligation of funds for such services.

**Semi-Permanent.** For the purposes of Medical Military Construction (MILCON), any structure designed to last between 5 and 25 years of useful life. An example is an overseas free-standing contingency facility off-base.

**Service Elevator.** An elevator that is “narrow and deep” in configuration to move patients and vehicular-type traffic between floors.

**Must.** Indicates a mandatory requirement, synonymous with “will.”

**Should.** Indicated a recommendation or alternative that is highly advised but not absolutely required.

**Simulation.** The use of a computer program as a model of a real situation.

**Single-Loaded Corridor.** A corridor with a single entry and exit point.

**Sound Transmission Class (STC).** A single-number rating system that compares the sound transmission loss of a test specimen with a standard contour.

**Standby Mode.** A critical facility capable of quickly, and with minimum effort, transforming from its peacetime mode of operation to a higher level of preparedness. Ready for the next higher Operationally Ready Mode.

**Statement of Work or Scope of Work (SOW).** A formalized document describing the details of an effort to be accomplished through contracted resources.

**State-of-the-Art.** The level of development (as of a device, procedure, process, technique, or science) reached at any particular time usually as a result of modern methods.

**Status of Forces Agreements (SOFA).** Agreements between the U.S. Government and the government of a foreign nation (host nation) that allows U.S. Forces to engage in some activity (such as occupy, build, or otherwise have temporary rights) that otherwise would not be possible. SOFA agreements usually stipulate governing rules, codes, and standards that must be followed in the course of construction on that nation's soil.

**Structural Interior Design (SID).** The portion of basic design services concerned with establishment of "motif," color, and finish selection usually very early in the Concept Design phase of all fixed, "structurally related" finishes, i.e., walls, floors, ceilings, columns, fixtures, casework, equipment, and exteriors, as opposed to Comprehensive Interior Design (CID) that is an option to design services and relates to such things as moveable, mobile, or portable equipment, fixtures, and furnishings. For unity of color selection and design, both the SID and the CID must be compatible, conform to the finish schedule, and coordinate early and throughout the design, procurement, construction, and installation processes. Reference Chapter 3 Design and Chapter 6 Architectural.

**Sustainable Design.** Design, construction, operation, and reuse/removal of the built environment in an environmentally and energy-efficient manner.

**Tactical (Operational) Mode.** A critical facility, having completed its Operationally Ready functional checks, and activated its limited number of simple tasks during changeover, that is operating in an independent, sustained, continuous operation without resupply for a predetermined period of time. This is the highest level of preparedness or operation.

**The Joint Commission (TJC).** Private, not-for-profit organization composed of representatives of the American College of Surgeons, American College of Physicians, American Hospital Association, American Medical Association, and American Dental Association whose purpose is to establish standards for the operation of health facilities and services, conduct surveys, and determine accreditation status of medical treatment facilities.

**Total Building Commissioning (TBCx).** Commissioning is defined by the building industry as the process of verifying that all building systems perform interactively according to the design intent, and the systems meet the Owner's operational needs. Reference Chapter 1 Introduction.

**Total Gross Area.** The total area including intra-departmental circulation, inter-departmental circulation, walls and structure, mechanical space, and total net area.

**Universal X-Ray Room.** The universal X-ray room must be capable of accepting all routine radiographic, fluoroscopic, and tomographic equipment up to 1200 milliampères (mA), 150 kVp, regardless of manufacture, during initial installation and subsequent replacement actions with little, if any, facility modification. The procedures must be

performed unencumbered and without any restriction of system components, patient size, or any known procedure that any installed X-ray equipment can perform now or in the future. This definition does not apply to digital radiography, special procedure rooms, C-arms, or angiography rooms. Reference Appendix D Universal X-Ray Room.

**Using Agency.** The using Military Department Surgeons General representative and/or DHA.

**Value Engineering (VE).** Value engineering studies consist of analyses of certain high-cost areas of a design to determine if an alternate way exists to achieve the same or improved function at a lower life-cycle cost (LCC). The main objectives of VE studies are reduced LCC and improved quality of design. The application of value engineering must not result in a lowering of criteria, quality standards, or reduction of scope as established by the guidance in this document. Reference Chapter 3 Design.

**Vehicular Traffic.** Generally defined as that traffic that is pushed or rolled into elevators on wheels. Examples of vehicular traffic are beds and gurneys. Wheelchairs are considered vehicular traffic where they are pushed by an escort or attendant, and where the occupant is a patient. Where wheelchairs carry staff or visitors, they are generally counted in with the pedestrian population since they would utilize passenger elevators.

**War Reserve Material (WRM).** Material required to augment peacetime assets to completely support forces, missions, and activities reflected in DoD/Joint Chiefs of Staff war plans.

**Whole Building Design Guide (WBDG).** WBDG was created to assist the design community with integrating Government criteria, non-Government standards, vendor data, and expert knowledge into a 'whole building' perspective. This 'whole building' concept is an integrated design approach that employs a collaborative team process to achieve high-performance buildings.

**Working Drawings.** The second phase of the Design process that includes the final development of all contract documents to prepare for the bidding phase.

**X-Ray Installations (Long-Time Rating).** A rating based on an operating interval of 5 minutes or longer.

**X-Ray Installations (Mobile).** X-ray equipment mounted on a permanent base with wheels or casters for moving while completely assembled.

**X-Ray Installations (Momentary Rating).** A rating based on an operating interval that does not exceed 5 seconds.

**X-Ray Installations (Portable).** X-ray equipment designed to be hand-carried.

**X-Ray Installations (Transportable).** X-ray equipment to be installed in a vehicle or that may be readily disassembled for transport in a vehicle.

*This Page Intentionally Left Blank*

CANCELLED



## APPENDIX I REFERENCES

### AIR FORCE SURGEON GENERAL

*AFMS Interior Design Standards*

### CENTERS FOR DISEASE CONTROL AND PREVENTION

<http://www.cdc.gov/biosafety/publications/bmbl5/>.

*Biosafety in Microbiological and Biomedical Laboratories (BMBL) 5th Edition*

### DEFENSE HEALTH AGENCY (DHA)

<https://facilities.health.mil>

*Achieving World-Class – An Independent Review of the Design Plans for the Walter Reed National Military Medical Center and the Fort Belvoir Community Hospital, May 2009, National Capital Region Base Realignment and Closure Health Systems Advisory Subcommittee of the Defense Health Board*

CEHNC-EDX, *Hospital Electrical Code Study, U.S. versus German Codes, Contract W912DY-13-D-0123.*

DHA/FE World Class Facilities Toolkit

MHS Capital Investment Decision Model Process Guide (CIDM-PG)

MHS Facility Life Cycle Management (FLCM) Building Information Modeling (BIM) Minimum Requirements

### DEPARTMENT OF DEFENSE

<http://www.dtic.mil/whs/directives>

DD Form 1391, FY\_\_ Military Construction Project Data

DoD Directive 4270.5, SUBJECT: Military Construction

DoDI 6015.17, SUBJECT: *Military Health System (MHS) Facility Portfolio Management*

DoDI 6055.01, SUBJECT: *DoD Safety and Occupational Health (SOH) Program*

### DEPARTMENT OF LABOR

[www.osha.gov](http://www.osha.gov)

OSHA - Part 1910, *Occupational Safety and Health Standards*

**ENVIRONMENTAL PROTECTION AGENCY**

<http://www.energystar.gov>

ENERGY STAR, U.S. Department of Energy, US EPA

<http://www.epa.gov>

Significant New Alternatives Policy (SNAP) Program

**FEDERAL AVIATION ADMINISTRATION**

<http://www.faa.gov>

AC150/5345-49C, *Specification L-854, Radio Control Equipment*

**FOOD AND DRUG ADMINISTRATION**

<http://www.fda.gov>

*Controlled Substances Act*

*Food Code*

*Hazard Analysis and Critical Control Points (HACCP)*

**NATIONAL INSTITUTE OF STANDARDS AND TECHNOLOGY (NIST)**

<http://fire.nist.gov>

NBSIR 85-3158, *Fire Performance of Interstitial Space Construction System*

**OFFICE OF THE DEPUTY UNDER SECRETARY OF DEFENSE, INSTALLATIONS AND ENVIRONMENT**

ODUSD(I&E) Memorandum, *Subject: Department of Defense Sustainable Buildings Policy*

ODUSD(I&E) Memorandum, *Subject: DoD Implementation of Storm Water Requirements under Section 438 of the Energy Independence and Security Act (EISA)*

**OFFICE OF MANAGEMENT AND BUDGET (OMB)**

<http://www.whitehouse.gov>

Circular No. A-131, May 21, 1993, *Value Engineering*

NISTIR 5560, *Fire Performance of an Interstitial Space Construction System*

**PHARMACOPOEIA (USP)**

<http://www.usp.org>

USP 797, *General Chapter 797, Pharmaceutical Compounding — Sterile Preparations*

USP 800, *Hazardous Drugs – Handling in Healthcare Settings*

**UNIFIED FACILITIES CRITERIA**

<https://wbdg.org/ffc/dod/unified-facilities-criteria-ufc>

UFC 1-200-01, *General Building Requirements*

UFC 1-200-02, *High Performance and Sustainable Building Requirements*

UFC 1-300-09N, *Design Procedures*

UFC 3-101-01, *Architecture*

UFC 3-240-01, *Wastewater Collection*

UFC 3-260-01, *Airfield and Heliport Planning and Design*

UFC 3-301-01, *Structural Engineering*

UFC 3-310-04, *Seismic Design for Buildings*

UFC 3-400-01, *Energy Conservation*

UFC 3-400-02, *Design: Engineering Weather Data*

UFC 3-410-01, *Mechanical Engineering*

UFC 3-420-01, *Plumbing Systems*

UFC 3-450-01, *Noise and Vibration Control*

UFC 3-490-06, *Elevators*

UFC 3-501-01, *Electrical Engineering*

UFC 3-520-01, *Interior Electrical Systems*

UFC 3-530-01, *Interior and Exterior Lighting Systems and Controls*

UFC 3-535-01, *Visual Air Navigation Facilities*

UFC 3-535-02, *Design Drawings for Visual Air Navigation Facilities*

UFC 3-540-01, *Engine Driven Generator Systems for Backup Power Applications*

UFC 3-575-01, *Lightning and Static Electricity Protection Systems*

UFC 3-580-01, *Telecommunications Interior Infrastructure Planning and Design*

UFC 3-600-01, *Fire Protection Engineering for Facilities*

UFC 3-701-01, *DoD Facility Pricing Guide*

UFC 3-730-01, *Programming Cost Estimates for Military Construction*

UFC 3-740-05, *Handbook: Construction Cost Estimating*

UFC 4-010-01, *DoD Minimum Antiterrorism Standards for Buildings*

UFC 4-020-01, *DoD Security Engineering Facilities Planning Manual*

UFC 4-021-01, *Design and O&M: Mass Notification Systems*

UFC 4-021-02, *Electronic Security Systems*

UFC 4-023-03, *Design of Buildings to Resist Progressive Collapse*

UFC 4-030-01, *Sustainable Development*

UFC 4-159-01N, *Design: Hyperbaric Facilities*

#### **UNITED STATES ACCESS BOARD**

<https://www.access-board.gov>

*Architectural Barriers Act (ABA) Accessibility Standard for DoD Facilities, 23 July 2004*

*Architectural Barriers Act (ABA) Standards*

DoD Policy Memorandum, *SUBJECT: Access for People with Disabilities, 31 October 2008*

#### **UNITED STATES CODE**

<http://www.gpo.gov/fdsys/browse/collectionUScode.action?collectionCode=USCODE>

10 U.S.C. Section 2807, *Architectural and Engineering Services and Construction Design*, Office of the Law Revision Counsel of the U.S. House of Representatives

10 U.S.C. Section 2851, *Supervision of military construction projects*, Office of the Law Revision Counsel of the U.S. House of Representatives

10 U.S.C. Section 2853, *Authorized cost and scope of work variations*, 2010, Office of the Law Revision Counsel of the U.S. House of Representatives

10 U.S.C. TITLE 10 - *ARMED FORCES*, January 2011, Office of the Law Revision  
Counsel of the U.S. House of Representatives

**UNITED STATES CODE OF FEDERAL REGULATIONS**

<http://www.gpo.gov/fdsys/browse/collectionCfr.action?collectionCode=CFR>

10 CFR Part 436.20, *Net savings*

10 CFR Part 436.21, *Savings-to-investment ratio*

10 CFR Part 436.22, *Adjusted internal rate of return*

21 CFR 1310.72, *Physical security controls for non-practitioners; narcotic treatment programs and compounders for narcotic treatment programs; storage areas*

29 CFR 1910.134, *Respiratory Protection*, Occupational Safety & Health Administration (OSHA)

29 CFR 1910.1030, *Bloodborne pathogens*, Occupational Safety & Health Administration (OSHA)

29 CFR 1910.1200, *Hazard Communication*, Occupational Safety & Health Administration (OSHA)

40 CFR Part 22, *Consolidated Rules of Practice Governing the Administrative Assessment of Civil Penalties and the Revocation/Termination or Suspension of Permits*

40 CFR Part 261, *Identification and Listing of Hazardous Waste*

40 CFR Part 262, *Standards Applicable to Generators of Hazardous Waste*

40 CFR Part 263, *Standards Applicable to Transporters of Hazardous Waste*

40 CFR Part 264, *Standards for Owners and Operators of Hazardous Waste Treatment, Storage, and Disposal Facilities*

40 CFR Part 265, *Interim Status Standards for Owners and Operators of Hazardous Waste Treatment, Storage, and Disposal Facilities*

47 CFR Part 15, Telecommunication, Part 15 – *Radio Frequency Devices*

47 CFR Part 76, Telecommunication, Part 76 – *Multichannel Video and Cable Television Service*

49 CFR 171, *General Information, Regulations, and Definitions*

49 CFR 172, *Hazardous Materials Table, Special Provisions, Hazardous Materials Communications, Emergency Response Information, Training Requirements, and Security Plans*

49 CFR 173, *Shippers – General Requirements for Shipments and Packagings*

49 CFR 174, *Carriage by Rail*

49 CFR 175, *Carriage by Aircraft*

49 CFR 176, *Carriage by Vessel*

49 CFR 177, *Carriage by Public Highway*

49 CFR 178, *Specifications for Packagings*

49 CFR 179, *Specifications for Tank Cars*

49 CFR 180, *Continuing Qualification and Maintenance of Packagings*

#### **AIR CONDITIONING AND REFRIGERATION INSTITUTE**

[www.ansi.org](http://www.ansi.org).

ARI 1010-2002, *Self-Contained, Mechanically-Refrigerated Drinkingwater Coolers*

#### **AMERICAN CONFERENCE OF GOVERNMENTAL INDUSTRIAL HYGIENISTS (ACGIH)**

*Manual of Recommended Practices for Industrial Ventilation*

#### **AMERICAN NATIONAL STANDARDS INSTITUTE**

<http://www.ansiz97.com>

ANSI C84.1- *American National Standard for Electric Power Systems and Equipment - Voltage Ratings (60 Hz)*

<https://www.ies.org>

ANSI/IESNA RP-29, *Lighting for Hospitals and Health Care Facilities*

#### **AMERICAN NATIONAL STANDARDS INSTITUTE/ACOUSTICAL SOCIETY OF AMERICA**

ANSI/ASA S3.2-2009, (R2014) *Method for Measuring the Intelligibility of Speech over Communications Systems*

#### **AMERICAN NATIONAL STANDARDS INSTITUTE/AMERICAN SOCIETY OF SAFETY PROFESSIONALS**

ANSI/ASSP Z590.3: *Prevention through Design Guidelines for Addressing Occupational Hazards and Risks in Design and Redesign Processes*

**AMERICAN SOCIETY OF CIVIL ENGINEERS/STRUCTURAL ENGINEERING INSTITUTE**

<http://www.seinstitute.org>

ASCE/SEI 7-16, *Minimum Design Loads for Buildings and Other Structures*

ASCE/SEI 24-05, *Flood Resistant Design and Construction*

**AMERICAN SOCIETY OF HEATING, REFRIGERATION AND AIR-CONDITIONING ENGINEERS**

[www.ashrae.org](http://www.ashrae.org)

ANSI/ASHRAE 15-2016, *Safety Standard for Refrigeration Systems*

ANSI/ASHRAE 34-2016, *Designation and Safety Classification of Refrigerants*

ANSI/ASHRAE 52.2-2017, *Method of Testing General Ventilation Air-Cleaning Devices for Removal Efficiency by Particle Size*

ANSI/ASHRAE 62.1, *Ventilation for Acceptable Indoor Air Quality*

ANSI/ASHRAE 90.1, *Energy Standard for Buildings Except Low-Rise Residential Buildings*

ASHRAE Guideline 0-2013, *The Commissioning Process*

ASHRAE Guideline 1.1-2007, *HVAC&R Technical Requirements for The Commissioning Process*

ASHRAE Handbook Series

ASHRAE Handbook: *Fundamentals*

ASHRAE Handbook: *HVAC Applications*

**AMERICAN SOCIETY OF MECHANICAL ENGINEERS INTERNATIONAL**

ASME A112 Standard Series, *Plumbing Fixtures and Appurtenances, e.g., "Enameled Cast Iron Plumbing Fixtures," "Vitreous China Plumbing Fixtures," and "Porcelain Enameled Formed Steel Plumbing Fixtures"*

ASME A17.1/CSA B44-2016, *Safety Code for Elevators and Escalators*

ASME A17.2, *Guide for Inspection of Elevators, Escalators, and Moving Walks*

ASME A17.3, *Safety Code for Existing Elevators and Escalators (Includes Requirements for Electric and Hydraulic Elevators and Escalators)*

ASME A17.5/CSA B44.1 - 2014, *Elevator and Escalator Electrical Equipment*

### **AMERICAN SOCIETY OF PLUMBING ENGINEERS**

[www.aspe.org](http://www.aspe.org)

ASPE Data Book, Chapter 4 “Service Water Heating Systems”

### **ASTM INTERNATIONAL**

[www.astm.org](http://www.astm.org)

ASTM C1071 - 05e1, *Standard Specification for Fibrous Glass Duct Lining Insulation (Thermal and Sound Absorbing Material)*

ASTM D1193-06, *Standard Specification for Reagent Water*

ASTM D975-17, *Standard Specification for Diesel Fuel Oils*

ASTM E136, *Standard Test Method for Behavior of Materials in a Vertical Tube Furnace at 750°*

ASTM E814, *Standard Test Method for Fire Tests of Through-Penetration Fire Stops*

### **CARPET AND RUG INSTITUTE (CRI) FACT SHEET**

<http://dpmcare.com>

*Carpet and Rug Institute (CRI) Fact Sheet*

### **CENTERS FOR DISEASE CONTROL AND PREVENTION**

<http://www.cdc.gov/biosafety/publications/bmbl5/>.

*Biosafety in Microbiological and Biomedical Laboratories (BMBL) 5th Edition*

### **COMPRESSED GAS ASSOCIATION**

[www.cganet.com](http://www.cganet.com)

CGA Pamphlet C-9, *Standard Color-Marking of Compressed Gas Containers for Medical Use*

CGA Pamphlet P-2, *Characteristics and Safe Handling of Medical Gases*



CGA Pamphlet V-5, *Diameter-Index Safety System (Noninterchangeable Low Pressure Connections for Medical Gas Applications)*

**DOOR AND HARDWARE INSTITUTE (DHI)**

<http://www.dhi.org>

*Hardware for Healthcare Facilities*

**ILLUMINATING ENGINEERING SOCIETY**

<http://www.ies.org/handbook>

IES, *Model Lighting Ordinance (MLO)*

IES, *Lighting Handbook*

IES RP-29, *Lighting for Hospitals and Healthcare Facilities*

IES TM-30, *Method for Evaluating Light Source Color Rendition*

**INSTITUTE OF ELECTRICAL AND ELECTRONICS ENGINEERS**

<https://standards.ieee.org>

IEEE C2, *National Electrical Safety Code (NEC)*

IEEE STD 242, *IEEE Recommended Practice for Protection and Coordination of Industrial and Commercial Power Systems*

IEEE STD 1789, *IEEE Recommended Practices for Modulating Current in High-Brightness LEDs for Mitigating Health Risks to Viewers*

**INTERNATIONAL CODE COUNCIL**

<http://shop.iccsafe.org/>

IBC-2015, *2015 International Building Code*

*International Plumbing Code*

**INTERNATIONAL ORGANIZATION FOR STANDARDIZATION**

[www.iso.org](http://www.iso.org)

ISO 7396-1:2016, *Medical gas pipeline systems -- Part 1: Pipeline systems for compressed medical gases and vacuum*

ISO 7396-2:2007, *Medical gas pipeline systems -- Part 2: Anaesthetic gas scavenging disposal systems*

ISO 9170-1:2017, *Terminal Units for Medical Gas Pipeline Systems - Part 1: Terminal Units for Use with Compressed Medical Gases and Vacuum*

ISO 9170-2:2008, *Terminal units for medical gas pipeline systems -- Part 2: Terminal units for anesthetic gas scavenging systems*

**NATIONAL COUNCIL ON RADIATION PROTECTION AND MEASUREMENTS  
(NCRP)**

<http://www.ncrponline.org>

NCRP Report No. 102, *Medical X-Ray, Electron Beam and Gamma-Ray Protection For Energies Up to 50 MeV (Equipment Design, Performance and Use)*

NCRP Report No. 147, *Structural Shielding Design for Medical X-Ray Imaging Facilities*

**NATIONAL FIRE PROTECTION ASSOCIATION**

[www.nfpa.org](http://www.nfpa.org)

NFPA 2, *Hydrogen Technologies Code*

NFPA 13, *Standard for the Installation of Sprinkler Systems*

NFPA 30, *Flammable and Combustible Liquids Code*

NFPA 37, *Installation and Use of Stationary Combustion Engines and Gas Turbines*

NFPA 45, *Standard for Fire Protection for Laboratories Using Chemicals*

NFPA 45, *Standard for Fire Protection for Laboratories Using Chemicals*

NFPA 54, *National Fuel Gas Code*

NFPA 55, *Compressed Gases and Cryogenic Fluids Code*

NFPA 70, *National Electrical Code*

NFPA 72, *National Fire Alarm and Signaling Code*

NFPA 80, *Standard for Fire Doors and Other Opening Protectives*

NFPA 82, *Standard on Incinerators and Waste and Linen Handling Systems and Equipment*

NFPA 90A, *Standard for the Installation of Air Conditioning and Ventilating Systems*

NFPA 92, *Standard for Smoke Control Systems*

NFPA 96, *Standard for Ventilation Control and Fire Protection of Commercial Cooking Operations*

NFPA 99, *Health Care Facilities Code*

NFPA 101, *Life Safety Code*

NFPA 101A, *Guide on Alternative Approaches to Life Safety*

NFPA 101M, *Manual on Alternative Approaches to Life Safety*

NFPA 110, *Emergency and Standby Power Systems*

NFPA 150, *Standard on Fire and Life Safety in Animal Housing Facilities*

NFPA 251, *Standard Methods of Tests of Fire Resistance of Building Construction and Materials*

NFPA 418, *Standard for Heliports*

NFPA 780, *Installation of Lightning Protection Systems*

#### **NATIONAL INSTITUTE OF BUILDING SCIENCES**

NIBS Guideline 3-2012, *Exterior Enclosure Technical Requirements For the Commissioning Process*

#### **NATIONAL RESEARCH COUNCIL, THE NATIONAL ACADEMIES PRESS**

<http://www.aaalac.org/resources>

*Guide for the Care and Use of Laboratory Animals, Eighth Edition, 2011*, Committee for the Update of the Guide for the Care and Use of Laboratory Animals

#### **NSF INTERNATIONAL**

[www.nsf.org](http://www.nsf.org)

NSF/ANSI 49-2016, *Biosafety Cabinetry: Design, Construction, Performance, and Field Certification*

#### **SHEET METAL AND AIR CONDITIONING CONTRACTORS' NATIONAL ASSOCIATION (SMACNA)**

<http://www.smacna.org>

*HVAC Systems-Duct Design, 4th Edition, 2006*

*IAQ Guidelines for Occupied Buildings Under Construction*

**TELECOMMUNICATIONS INDUSTRY ASSOCIATION (TIA)**

TIA-1179, *Healthcare Facility Telecommunications Infrastructure Standard*

TIA-222, *Structural Standard for Antenna Supporting Structures and Antennas*,  
December 2009, Telecommunications Industry Association

TIA-329, *Minimum Standards for Communications Antennas*

TIA-568, *Commercial Building Telecommunications Cabling Standard*

TIA-569-A, *Commercial Building Standard for Telecommunications Pathways and Spaces*

TIA-606, *Administration Standard for the Commercial Telecommunications Infrastructure*

TIA-607, *Generic Telecommunications Bonding and Grounding (Earthing) for Customer Premises*

TIA-758, *Customer-Owned Outside Plant Telecommunications Infrastructure Standard*

**THE JOINT COMMISSION**

<http://www.jointcommission.org/>

*Comprehensive Accreditation Manual for Hospitals (CAMH)*

**UNDERWRITERS LABORATORIES INC.**

[www.ul.com](http://www.ul.com)

UL 181, *Standard for Factory-Made Air Ducts and Air Connectors*

UL 1069, *Hospital Signaling and Nurse Call Equipment*

UL 1778, *Uninterruptable Power Systems*

**WHOLE BUILDING DESIGN GUIDE**

[http://www.wbdg.org/references/pa\\_dod.php](http://www.wbdg.org/references/pa_dod.php)

*DoD Space Planning Criteria for Health Facilities*

*Federal Leadership in High Performance and Sustainable Buildings Memorandum of Understanding*

MIL-HNBK-419A, *Grounding, Bonding, and Shielding for Electronic Equipments and Facilities*

Military Health System (MHS) *Templates (formerly "Guide Plates")*

Military Health System (MHS): *DoD Space Planning Criteria for Health Facilities*

MIL-STD-1691, *Construction and Material Schedule for Military Medical and Dental Facilities*

MIL-STD-3007, *Standard Practice for Unified Facilities Criteria and Unified Facilities Guide Specifications*

NAVAIR 51-50AAA-2, *General Requirements for Shore Based Airfield Marking and Lighting*

**OTHER REFERENCES:**

DEFENSE HEALTH BOARD (<http://www.health.mil/>), Military Health System - The Pentagon, Washington, D.C. 20301-1200.

DoD Financial Management Regulation 7000.14-R, Office of the Under Secretary of Defense (Comptroller), <http://comptroller.defense.gov/fmr/>

*Guidelines for Preventing the Transmission of Mycobacterium Tuberculosis in Health-Care Facilities* (the TB Guidelines), October 28, 1994, Federal Register Vol. 59, No. 208, <http://www.gpo.gov/fdsys/pkg/FR-1994-10-28/html/94-26598.htm>.

HISTORICAL ANALYSIS GENERATOR, Project Time & Cost, Inc. (for Tri-Service Automated Cost Engineering Systems), 2727 Paces Ferry Road, Suite 1-1200, Atlanta, GA 30339, 800.486.5752. <https://www.hnc.usace.army.mil/Media/Fact-Sheets/Fact-Sheet-Article-View/Article/482084/tri-services-automated-cost-engineering-system/>

MIL-E-8881, *Enclosure, Electromagnetic Shielding, Demountable, Prefabricated General Specification for*, U.S. Department of Defense

SS521-AA-MAN-010, *Hyperbaric Systems Safety Certification Manual*

*This Page Intentionally Left Blank*

CANCELLED