

UNIFIED FACILITIES CRITERIA (UFC)

ENGINE-DRIVEN GENERATOR SYSTEMS FOR BACKUP POWER APPLICATIONS



APPROVED FOR PUBLIC RELEASE; DISTRIBUTION UNLIMITED

ENGINE-DRIVEN GENERATOR SYSTEMS FOR BACKUP POWER APPLICATIONS

Any copyrighted material included in this UFC is identified at its point of use. Use of the copyrighted material apart from this UFC must have the permission of the copyright holder.

U.S. ARMY CORPS OF ENGINEERS (Preparing Activity)

NAVAL FACILITIES ENGINEERING COMMAND

AIR FORCE CIVIL ENGINEER CENTER

Record of Changes (changes are indicated by \1\ ... /1/)

Change No.	Date	Location

This UFC supersedes UFC 3-540-04N, Design: Diesel Electric Generating Plants, and TM 5-811-6, Electric Power Plant Design.

FOREWORD

The Unified Facilities Criteria (UFC) system is prescribed by MIL-STD 3007 and provides planning, design, construction, sustainment, restoration, and modernization criteria, and applies to the Military Departments, the Defense Agencies, and the DoD Field Activities in accordance with [USD \(AT&L\) Memorandum](#) dated 29 May 2002. UFC will be used for all DoD projects and work for other customers where appropriate. All construction outside of the United States is also governed by Status of Forces Agreements (SOFA), Host Nation Funded Construction Agreements (HNFA), and in some instances, Bilateral Infrastructure Agreements (BIA.) Therefore, the acquisition team must ensure compliance with the most stringent of the UFC, the SOFA, the HNFA, and the BIA, as applicable.

UFC are living documents and will be periodically reviewed, updated, and made available to users as part of the Services' responsibility for providing technical criteria for military construction. Headquarters, U.S. Army Corps of Engineers (HQUSACE), Naval Facilities Engineering Command (NAVFAC), and Air Force Civil Engineer Center (AFCEC) are responsible for administration of the UFC system. Defense agencies should contact the preparing service for document interpretation and improvements. Technical content of UFC is the responsibility of the cognizant DoD working group. Recommended changes with supporting rationale should be sent to the respective service proponent office by the following electronic form: [Criteria Change Request](#). The form is also accessible from the Internet sites listed below.

UFC are effective upon issuance and are distributed only in electronic media from the following source:

- Whole Building Design Guide web site <http://dod.wbdg.org/>.

Refer to UFC 1-200-01, *General Building Requirements*, for implementation of new issuances on projects.

AUTHORIZED BY:



JAMES C. DALTON, P.E.
Chief, Engineering and Construction
U.S. Army Corps of Engineers



JOE SCIABICA, SES
Director
Air Force Civil Engineer Center



JOSEPH E. GOTT, P.E.
Chief Engineer
Naval Facilities Engineering Command

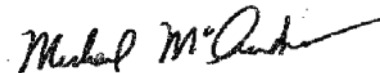

MICHAEL McANDREW
Director, Facilities Investment and Management
Office of the Deputy Under Secretary of Defense
(Installations and Environment)

**UNIFIED FACILITIES CRITERIA (UFC)
NEW DOCUMENT SUMMARY SHEET**

Document: 3-540-01, *Engine-Driven Generator Systems for Backup Power Applications*

Superseding:

- UFC 3-540-04N, *Design: Diesel Electric Generating Plants*
- TM 5-811-6, *Electric Power Plant Design*

Description: This UFC provides guidance for the design and installation of engine generator systems for use as backup power systems.

Reasons for Document:

- Provide technical requirements for design.
- Consolidate design criteria currently located in multiple documents.
- Update the existing material to reflect new and revised industry standards.

Impact: There are minor cost impacts associated with this UFC. However, the following benefits should be realized

- Standardized guidance has been prepared to assist engineers in the development of the plans, specifications, calculations, and Design/Build Request for Proposals (RFPs).
- Overlap of material with other UFCs has also been eliminated with the issue of this UFC.
- Adopting NFPA 110 as a basis for engine generator design results in additional requirements; however, these requirements are intended to improve the reliability of emergency generator installations.

Unification Issues

None.

TABLE OF CONTENTS

CHAPTER 1 INTRODUCTION	1
1-1 PURPOSE AND SCOPE.....	1
1-2 APPLICABILITY.....	1
1-3 GENERAL BUILDING REQUIREMENTS.	1
1-4 REFERENCES.	2
1-5 DESIGN STANDARDS.....	2
1-6 PROJECT REQUIREMENTS.....	2
1-7 GLOSSARY.....	2
CHAPTER 2 DESIGN GUIDANCE	3
2-1 APPLICATIONS.....	3
2-1.1 NFPA 110 Compliance.	3
2-1.2 NFPA 70 and NFPA 110 Compliance.....	4
2-2 AUTHORIZED FUEL TYPES.....	4
2-3 ONSITE FUEL STORAGE CAPACITY.....	4
2-4 ANALYSIS REQUIREMENTS.....	5
2-4.1 Design Analysis.	5
2-4.2 Power Rating Category.....	6
2-4.3 Performance Class Transient Limits.....	7
2-5 DESIGN CRITERIA.....	8
2-5.1 Circuit Wiring for Legally Required and Optional Standby Systems.	8
2-5.2 Automatic Startup.....	8
2-5.3 Single Operation Generator Sets.....	9
2-5.4 Paralleling Generator Applications.....	9
APPENDIX A REFERENCES.....	13
APPENDIX B EXAMPLES.....	15
B-1 SINGLE GENERATOR SYSTEM CONFIGURATIONS.....	15
B-1.1 Single Engine Generator Supply to Essential Loads.	15
B-1.2 Permanently Installed Engine Generator with Portable Connection. ...	15
B-1.3 Single Engine Generator Configuration for Whole Building Supply.	16
B-1.4 Single Engine Generator Configuration with Multiple ATS.....	17
B-1.5 Single Engine Generator with Redundant Utility Supply.	17
B-1.6 Dual Engine Generator with Redundant Utility Supply.....	18

B-2	PARALLEL GENERATOR SYSTEM CONFIGURATIONS.....	19
B-2.1	Utility Supply.....	19
B-2.2	Parallel Generator Control Systems.....	20
B-3	AUTOMATIC TRANSFER SWITCH CONFIGURATIONS.....	21
APPENDIX C CHECKLIST.....		23
C-1	GENERAL.....	23
C-2	ELECTRICAL.....	23
C-3	MECHANICAL.....	25
C-4	CIVIL/STRUCTURAL.....	27
C-5	ARCHITECTURAL.....	27
APPENDIX D GENERATOR SIZING.....		29
D-1	LOAD EVALUATION.....	29
D-1.1	Uninterruptible, Essential, and Nonessential Loads.....	29
D-1.2	Conditions of Loading.....	30
D-1.3	Nonlinear Loads.....	30
D-1.4	Step Loading.....	30
D-1.5	Motor Starting Requirements.....	31
D-2	GENERATOR RATING.....	31
D-2.1	Industry Ratings.....	31
D-2.2	Generator Capacity Rating.....	32
D-2.3	Uninterruptible Power Supply (UPS) Systems.....	32
D-2.4	Power Quality.....	33
APPENDIX E CONNECTION METHODS FOR PORTABLE GENERATORS.....		35
E-1	INTRODUCTION.....	35
E-2	CONNECTION METHODS.....	35
E-2.1	MIL-C-22992, Class L, QWLD-Rated Connectors.....	35
E-2.2	Single-Pole (Cam-Lok style) Connectors.....	36
APPENDIX F FACILITY DESIGN TYPES.....		39
APPENDIX G GLOSSARY.....		45
G-1	ACRONYMS.....	45
G-2	DEFINITION OF TERMS.....	47

FIGURES

Figure B-1 Typical Single Engine Generator Configuration..... 15
Figure B-2 Configuration for Permanently Installed and Portable Generator 16
Figure B-3 Whole Building Generator Supply Configuration 16
Figure B-4 Configuration to Supply Multiple ATS 17
Figure B-5 Selection Between Redundant Utility Supply and Generator..... 18
Figure B-6 Selection Between Redundant Utility Supply and Dual Generators..... 19
Figure B-7 Parallel Generators with Single Utility Supply..... 19
Figure B-8 Parallel Generators with Alternate Utility Supply 20
Figure B-9 Parallel Generators with Alternate Utility Supply for UPS Systems 20
Figure B-10 Parallel Generator Control System Architecture 21
Figure B-11 Typical Four-Pole ATS Arrangement..... 21
Figure B-12 Typical Three Pole ATS Arrangement 22

TABLES

Table 2-1 Performance Class Transient Limits 8
Table F-1 Naval Facilities Authorized for Backup Power..... 40
Table F-2 UFCs Addressing Backup Power Requirements..... 42

CANCELLED

CHAPTER 1 INTRODUCTION

1-1 PURPOSE AND SCOPE.

This Unified Facilities Criteria (UFC) has been issued to provide guidance for the design of generator systems for backup power applications.

The information provided here must be utilized by engineers in the development of the plans, specifications, calculations, and Design/Build Request for Proposals (RFP) and serves as the minimum design requirements. It is applicable to the traditional services customary for Design-Bid-Build construction contracts and for Design-Build construction contracts. Project conditions may dictate the need for a design that exceeds these minimum requirements.

1-2 APPLICABILITY.

Compliance with this UFC is mandatory for the design and installation of engine-driven generator systems for backup power applications at all DoD installations. The connection of portable generator systems to a facility is covered by this UFC. Refer to Appendix E regarding portable generator connection design criteria. This UFC does not apply to:

- Tactical engine generators.
- Prime power applications. A prime power application is defined as electrical generation where there is no other source for primary electrical power. Prime power plants require specialized designs beyond the scope of this UFC; develop the design requirements for prime power plants on a project-by-project basis.

For the Air Force, Engineering Technical Letter (ETL) 13-4: *Standby Generator Design, Maintenance, and Testing Criteria*, defines emergency or standby generator authorizations. Design agencies are required to comply with this document.

1-3 GENERAL BUILDING REQUIREMENTS.

Comply with UFC 1-200-01, *General Building Requirements*. UFC 1-200-01 provides applicability of model building codes and government unique criteria for typical design disciplines and building systems, as well as for accessibility, antiterrorism, security, high performance and sustainability requirements, and safety. Use this UFC in addition to UFC 1-200-01 and the UFCs and government criteria referenced therein.

Modernization of existing systems solely for the purpose of meeting design criteria in this UFC is not required. Upgrades or modifications of existing facilities should consider the design criteria in this UFC, but it is not intended that an entire facility require modernization solely because of a minor modification to a part of the facility.

1-4 REFERENCES.

Appendix A contains a list of references used in this UFC. References applicable to a specific topic are also listed and described in the appropriate sections of this UFC.

1-5 DESIGN STANDARDS.

Codes and standards are referenced throughout this UFC. The publication date of the code or standard is not routinely included with the document identification throughout the text of the document. In general, the latest issuance of a code or standard has been assumed for use.

1-6 PROJECT REQUIREMENTS.

Provide analyses that document the multi-discipline requirements and impacts of the following:

- Facility – features and siting.
- System sizing and rating.
- System configuration.
- System operation and control.
- Emissions and permitting.
- Noise mitigation.
- Seismic classification.
- Fuel.
- Utility requirements for paralleling.

Appendix C provides a checklist of items to consider as part of system planning and design.

1-7 GLOSSARY.

Appendix G contains acronyms, abbreviations, and terms.

CHAPTER 2 DESIGN GUIDANCE

2-1 APPLICATIONS.

Refer to Appendix F for a list of facility types and typical applications within DoD. For the Army and Navy, the major command or program element determines if a generator system for backup power is required and its classification.

Refer to UFC 4-510-01 for generator system requirements associated with Medical Military Facilities.

2-1.1 NFPA 110 Compliance.

For permanently installed generator systems, comply with the NFPA 110 requirements for emergency power supply systems (EPSS) with the following clarifications.

2-1.1.1 Classification.

Designate the EPSS as Class X, where "X" is the required operating time in hours.

Designate the EPSS as Type 10 for medical systems covered by UFC 4-510-01 and Type 60 for all other applications.

2-1.1.2 Remote Manual Stop.

Provide a remote manual stop station for the EPSS in one of the following locations:

- In a separate room of the same building that houses the generator system.
- In a separate building that the generator system is serving.
- On the outside of the building that houses the generator system.
- On the outside of an enclosure that contains the generator system.

The requirement for a remote manual stop station may be deleted, such as when it has been determined that a location is not available that restricts access to unqualified operators. The designer of record must receive documentation from the activity that their fire marshal or designated equivalent concurs with this determination.

2-1.1.3 Remote Control and Alarm.

Provide a remote control and alarm panel for the EPSS in a separate room of the same building that houses the generator system or In a separate building that the generator system is serving. The requirement for a remote control and alarm panel may be deleted when it has been determined that a location is not available that restricts access

to unqualified operators or if not desired by the activity. The designer of record must receive documentation from the activity for this determination.

Provide a remote common audible alarm to a 24 hour staffed location when the EPSS location is not staffed 24 hours per day. The requirement for a remote common audible alarm may be deleted when it has been determined that a suitable location is not available or if not desired by the activity. The designer of record must receive documentation from the activity for this determination.

2-1.2 NFPA 70 and NFPA 110 Compliance.

Comply with NFPA 70 and NFPA 110 as follows.

- Generator systems that are required to comply with NFPA 70 Article 700, *Emergency Systems*, must also comply with NFPA 110 Level 1 criteria.
- Generator systems that are required to comply with NFPA 70 Article 708, *Critical Operations Power Systems (COPS)*, must also comply with NFPA 110 Level 2 criteria.
- Systems utilizing permanently installed generators that are not designated as Emergency Systems or COPS must comply with NFPA 70 Article 701, *Legally Required Standby Systems*, and also comply with NFPA 110 Level 2 criteria.
- Systems utilizing portable generators must comply with NFPA 70 Article 702, *Optional Standby Systems*.

2-2 AUTHORIZED FUEL TYPES.

Select diesel or diesel/jet fuel as the primary fuel source for applications where onsite storage is required. Natural gas can be used as the primary fuel source only for applications where onsite storage is not required.

- Diesel/natural gas dual fuel units are allowed. For the Air Force, natural gas systems are not allowed.
- Bio-diesel and liquefied petroleum gas (LPG) fuel types are not allowed.

2-3 ONSITE FUEL STORAGE CAPACITY.

Provide seven days of fuel storage either in a dedicated on-site main fuel tank or from a confirmed delivery source. Base this storage capacity on the fuel consumption required to support the mission load. When the seven day requirement is accomplished by a delivery source, provide each generator set with a minimum local 24 hour capacity tank based on the full-load fuel consumption rate of the engine.

The above requirements can be modified if it is validated (documented in writing and dated) that mission operations require a different operational duration (longer or shorter).

2-4 ANALYSIS REQUIREMENTS.

2-4.1 Design Analysis.

Provide a design analysis which covers the general facility design requirements in accordance with UFC 1-200-01 and its referenced documents. Document in the design analysis how compliance with NFPA 37, NFPA 70, and NFPA 110 is achieved. In addition to the UFC 3-501-01 requirements for preliminary basis of design and follow-on submittals, provide the following general system specific analysis information:

2-4.1.1 Facility – Features and Siting.

- Geographic and operating environment, including coastal locations/corrosive conditions, humidity, altitude, seismic zones, and ambient temperature extremes.
- Exhaust system design, including stack height and location.
- Vibration (transmitted to structures).
- Ventilation.

2-4.1.2 Engine Generator Sizing.

- Generator sizing calculations. The Designer of Record must use commercially available generator sizing software provided by a generator manufacturer to determine the required rating. Refer to Appendix D for additional information regarding generator sizing. Verify the commercially available sizing software addresses the generator sizing topics listed in Appendix D.
- Accommodate the effects or rating adjustments for nonlinear loads and uninterruptible power supply (UPS) systems.

2-4.1.3 System Configuration.

- Classification of loads.
- Redundancy.
- Maintenance and testing.

2-4.1.4 System Operation and Control.

- Load shed plan.
- Refueling capability to support generator operation during extended power outages at mission essential/critical facilities.

2-4.1.5 Emissions and permitting information as required to establish compliance with project requirements and environmental impact study.

2-4.1.6 Noise Mitigation.

2-4.1.7 Seismic Classification.

2-4.1.8 Fuel Storage Design and Capacity.

Apply UFC 3-460-01, *Design: Petroleum Fuel Facilities*.

2-4.1.9 Utility Requirements for Paralleling.

2-4.2 Power Rating Category.

Determine the required power rating category in accordance with ISO 8528-1, *Reciprocating internal combustion engine driven alternating current generating sets — Part 1: Application, ratings and performance*, and as described below.

Note: ISO 8528-1 was selected as a reference because it is the only industry standard that has defined power rating categories. Each manufacturer has developed their own unique rating definitions that may not comply with the ISO standard.

2-4.2.1 Continuous Power.

The maximum power which the generating set is capable of delivering continuously while supplying a constant electrical load when operated for an unlimited number of hours per year under the agreed operating conditions with the maintenance intervals and procedures being carried out as prescribed by the manufacturer.

Note: The continuous power category is unlikely to be required for the backup power applications associated with this UFC.

2-4.2.2 Prime Power.

The maximum power which a generating set is capable of delivering continuously while supplying a variable electrical load when operated for an unlimited number of hours per year under the agreed operating conditions with the maintenance intervals and procedures being carried out as prescribed by the manufacturer.

Note: The prime power rating category is required for generator systems designated as critical operations power systems (COPS) in accordance with NFPA 70 Article 708.

2-4.2.3 Limited Time Running Power.

The maximum power available, under the agreed operating conditions, for which the generating set is capable of delivering for up to 500 hours of operation per year with the maintenance intervals and procedures being carried out as prescribed by the manufacturers.

2-4.2.4 Emergency Standby Power.

The maximum power available during a variable electrical power sequence, under the stated operating conditions, for which a generating set is capable of delivering in the event of a utility power outage or under test conditions for up to 200 hours of operation per year with the maintenance intervals and procedures being carried out as prescribed by the manufacturers.

2-4.3 Performance Class Transient Limits.

Determine the required electrical performance class in accordance with ISO 8528-1, *Reciprocating internal combustion engine driven alternating current generating sets — Part 1: Application, ratings and performance*, and as described below. Transient response limits are provided in Table 2-1 in accordance with ISO 8528-5:2013, *Reciprocating internal combustion engine driven alternating current generating sets - Part 5: Generating sets*.

2-4.3.1 Class G1.

Connected loads require only basic parameters of voltage and, such as general purpose lighting and other simple electrical loads.

2-4.3.2 Class G2.

Applies to generating set applications where the required voltage characteristics are very similar to those for the commercial public utility electrical power system with which it operates. When load changes occur, there may be temporary but acceptable deviations of voltage and frequency. Examples of this category include lighting systems, pumps, fans, and hoists.

2-4.3.3 Class G3.

Applies to applications where the connected equipment makes severe demands on the stability and level of the frequency, voltage and waveform characteristics of the electrical power supplied by the generating set. Examples of this category include telecommunications and thyristor-controlled loads. Note that both rectifier and thyristor-controlled loads may need special consideration with respect to their effect on generator-voltage waveform. Class G3 loads require an evaluation by the designer of record to document the system voltage and frequency limitations, including transient response.

2-4.3.4 Class G4.

Applies to applications where the demands made on the stability and level of the frequency, voltage and waveform characteristics of the electrical power supplied by the generating set are exceptionally severe. Examples include data-processing equipment or computer systems. Class G4 loads require an evaluation by the designer of record to document the system voltage and frequency limitations, including transient response.

Table 2-1 Performance Class Transient Limits

Parameter	Performance Class			
	G1	G2	G3	G4
Frequency Deviation (Percent) for 100 Percent Load Increase	<-15	<-10	<-7	TBD
Frequency Deviation (Percent) for 100 Percent Load Decrease	<+18	<+12	<+10	TBD
Frequency Recovery Time (Seconds) for 100 Percent Load Change	<10	<5	<3	TBD
Voltage Deviation (Percent) for 100 Percent Load Increase	<-25	<-20	<-15	TBD
Voltage Deviation (Percent) for 100 Percent Load Decrease	<+35	<+25	<+20	TBD
Voltage Recovery Time (Seconds) for 100 Percent Load Change	<10	<6	<4	TBD
Frequency Droop (Percent)	<-8	<-5	<-3	TBD
Steady-State Frequency Band (Percent)	<2.5	<1.5	<0.5	TBD
Steady-State Voltage Regulation (Percent)	<5	<2.5	<1	TBD

Note: The Table 2-1 column for performance class G4 states “TBD”, which means that a site-specific analysis is required to determine the voltage and frequency limits.

2-5 DESIGN CRITERIA.

Note: Appendix B provides examples of various configurations.

2-5.1 Circuit Wiring for Legally Required and Optional Standby Systems.

For Legally Required (NFPA 70 Article 701) or Optional Standby Systems (NFPA 70 Article 702), keep the circuit wiring from the generator to the loads served entirely independent of all other general wiring unless otherwise permitted in NFPA 70 Article 700.

2-5.2 Automatic Startup.

Use fixed (permanently installed) generators with automatic startup for facilities designated as emergency and COPS systems.

Generators associated with facilities designated as standby systems may be either fixed or portable with automatic or manual startup.

2-5.3 Single Operation Generator Sets.

2-5.3.1 Configuration.

Configure single operation generator sets as separately derived systems.

Provide four-pole devices for a three-phase system to switch the supply to essential loads and to switch between multiple single operation generator sets.

2-5.3.2 Automatic Transfer Switches.

Use automatic transfer switches that are listed in accordance with UL 1008, *Automatic Transfer Equipment*. Provide drawout automatic transfer switches with integral maintenance bypass isolation for systems designated as Emergency, COPS, or where validated (documented in writing and dated) by the user as being required. Non-enclosed automatic transfer switches must be in a dedicated isolated compartment when installed in switchgear or switchboards. A design using double-throw safety switches to accomplish maintenance bypass is not allowed.

Provide an open transition transfer scheme unless facility operating procedures require paralleling with the utility. Closed transition transfer is rarely required for backup power applications. Closed transition will require coordination with the local utility and will require designing for the higher available short circuit current of the combined parallel power sources.

2-5.3.3 Automatic Transfer Switch Maintenance Access.

Ensure the ATS installation design allows the front-access enclosure door to be fully opened. Provide a minimum of 30 inches of working clearance around the ATS when it is in its withdrawn position.

2-5.3.4 Utility Service.

Provide draw out circuit breakers as the utility service disconnecting means when redundant utility services are provided to allow for maintenance without incurring power outages.

2-5.4 Paralleling Generator Applications.

2-5.4.1 Main Power Distribution Equipment.

Provide switchboard or switchgear construction with drawout power or insulated case circuit breakers for the main power distribution equipment. Provide a minimum of 30 inches of working clearance around each circuit breaker when in its withdrawn position.

2-5.4.2 Control Power.

Provide redundant AC control power for systems designated as Emergency, COPS, or where validated by the user as being required. Provide a redundant AC control power system that is selectable via an automatic transfer switch.

Provide redundant DC control power for systems designated as Emergency, COPS, or where validated by the user as being required. Provide a redundant DC control power system through a best battery selector.

2-5.4.3 Control System.

Provide the following:

2-5.4.3.1 Redundant master controllers that run the logic for all programmed and operator initiated automatic system sequences. The redundant master programmable logic controllers via paralleled input/output points must control and monitor the main breakers, the tie breakers, the feeder breakers (if load shedding is required), and the common system auxiliaries.

2-5.4.3.2 Separate and dedicated generator controllers that run the logic for operation of each respective generator set. Automatic startup of the generator sets must be via commands from the master controllers. Design system so that manual startup of the generator sets is via operator initiated commands independent of the master controllers. The generator controllers must control and monitor the generator breakers and associated generator set auxiliaries.

2-5.4.3.3 Close control commands for synchronizing that are direct outputs from separate controllers for each respective utility source and generator circuit breaker.

2-5.4.3.4 System operator interface via 15 inch TFT (thin film transfer) color touch panels. Provide a touch panel for each generator set plus one additional local panel and an optional remote panel. Each display controller must provide real-time graphical control and monitoring for the system and all generators.

2-5.4.3.5 Communication between the master controllers, the generator controllers, and the operator interface touch panels enabled via an Ethernet network configured in a ring with one of the Ethernet switches being a ring master. Provide connection of the touch panels and system controllers to the Ethernet network such that no two touch panels are connected to the same switch and no two controllers are connected to the same switch.

2-5.4.3.6 Breaker control switch for each main breaker, tie breaker, feeder breaker (if control is required for load shedding), and generator breaker to enable automatic control when the switch is in the "normal after close" position and disable automatic control when the switch is in the "normal after trip" position.

2-5.4.4 Protection.

Install current transformers (CTs) on the neutral side of the generator windings. Use these CTs as an input to a generator protective relay for overcurrent protection.

For medium voltage generators, provide zig-zag grounding transformers with a grounding resistor connected to the generator bus via a circuit breaker. Provide differential protection for the zig-zag transformer. Do not provide ground fault

protection; the purpose of the zig-zag transformer is to enable a reduced ground fault current.

CANCELLED

This Page Intentionally Left Blank

CANCELLED

APPENDIX A REFERENCES

Note: The most recent edition of referenced publications applies, unless otherwise specified.

UNIFIED FACILITIES CRITERIA

http://www.wbdg.org/ccb/browse_cat.php?o=29&c=4

UFC 1-200-01, *General Building Requirements*

UFC 3-460-01, *Design: Petroleum Fuel Facilities*

UFC 3-501-01, *Electrical Engineering*

UFC 4-510-01, *Design: Medical Military Facilities*

IEEE (FORMERLY INSTITUTE OF ELECTRICAL AND ELECTRONICS ENGINEERS)

IEEE Std 446-1995 (R 2000), *Recommended Practice for Emergency and Standby Power Systems for Industrial and Commercial Applications* (IEEE Orange Book).

NATIONAL FIRE PROTECTION ASSOCIATION

NFPA 30-2012, *Flammable and Combustible Liquids Code*

NFPA 37-2010 (Through AMD 3), *Standard for the Installation and Use of Stationary Combustion Engines and Gas Turbines*

NFPA 70-2014, *National Electrical Code*

NFPA 99-2012, *Health Care Facilities*

NFPA 110-2013 (Through AMD 5), *Emergency and Standby Power Systems*

MISCELLANEOUS DOCUMENTS

ISO 8528-1:2005, *Reciprocating internal combustion engine driven alternating current generating sets — Part 1: Application, ratings and performance*

ISO 8528-5:2013, *Reciprocating internal combustion engine driven alternating current generating sets - Part 5: Generating sets*

UL 1008-2012 (Reprint Aug 2013), *Automatic Transfer Equipment*

US Air Force Engineering Technical Letter (ETL) 13-4: *Standby Generator Design, Maintenance, and Testing Criteria*

CANCELLED

This Page Intentionally Left Blank

APPENDIX B EXAMPLES

Appendix B provides examples and simple depictions of different configurations.

B-1 SINGLE GENERATOR SYSTEM CONFIGURATIONS.

B-1.1 Single Engine Generator Supply to Essential Loads.

If the facility has a permanently installed emergency power source, provide a separate panel to supply only the loads requiring emergency power. This panel will normally be supplied by the upstream main distribution panel. Figure B-1 provides an example of this configuration

Figure B-1 Typical Single Engine Generator Configuration

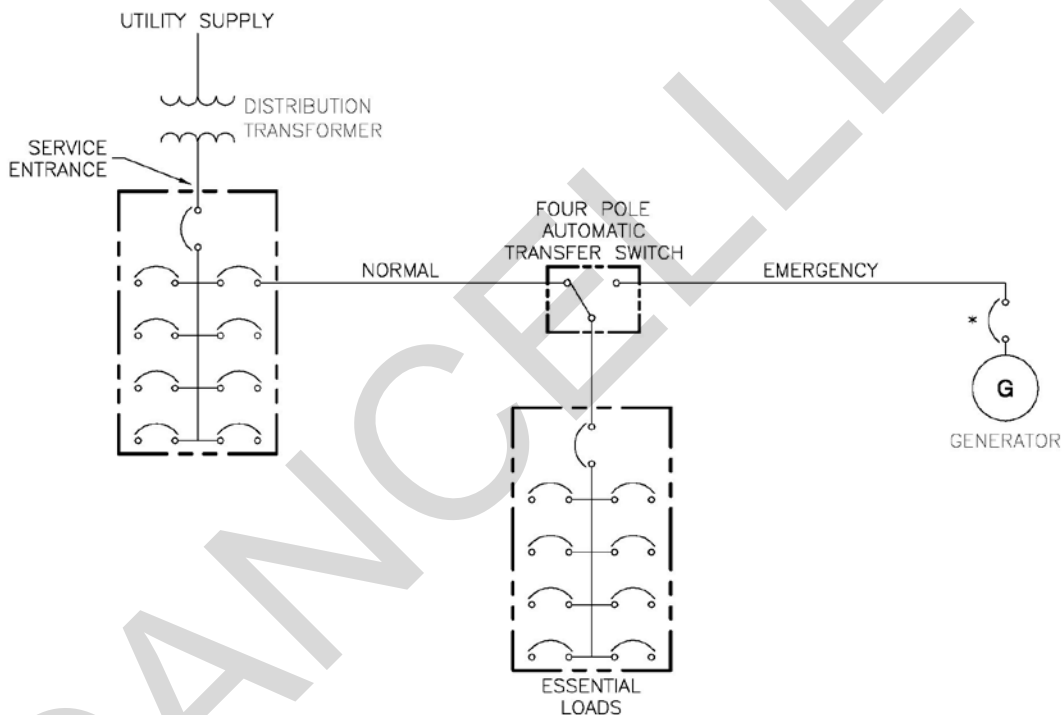

* Note that the circuit breaker shown on the generator can be located on the generator skid, in a separate enclosure mounted adjacent to the ATS, or integral with the ATS.

B-1.2 Permanently Installed Engine Generator with Portable Connection.

If the facility is designed with a permanently installed generator and a connection for a portable generator, do not connect the conductors for both generators directly onto the emergency side of the associated ATS. Install a double-throw switch upstream of the ATS; connect the permanently installed generator and the portable generator connection to this double-throw switch, with the output of the switch connected to the ATS. Figure B-2 provides an example.

Figure B-2 Configuration for Permanently Installed and Portable Generator

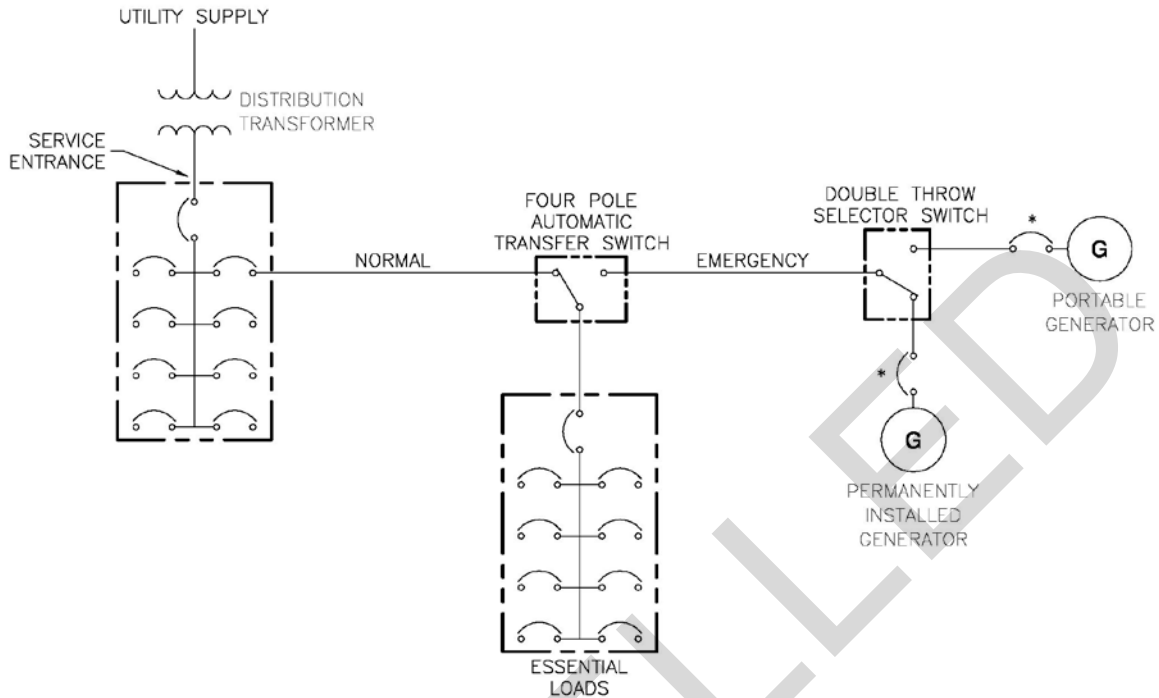

B-1.3 Single Engine Generator Configuration for Whole Building Supply.

If the engine generator is designed to supply the entire facility, provide circuit breakers on each supply to the ATS as shown in Figure B-3.

Figure B-3 Whole Building Generator Supply Configuration

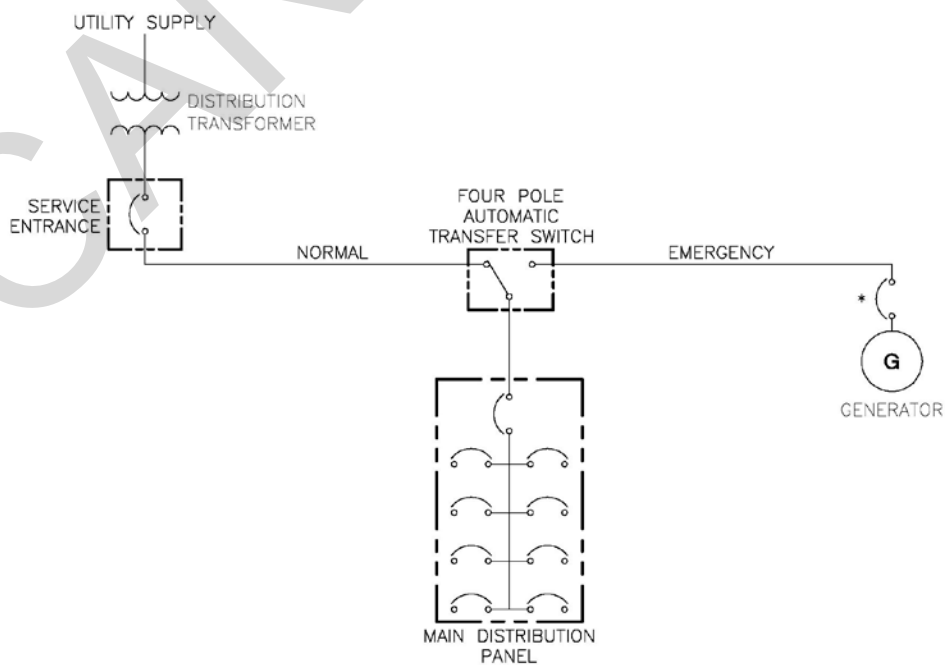

B-1.4 Single Engine Generator Configuration with Multiple ATS.

If the engine generator supplies more than one ATS, install an emergency distribution panelboard or switchboard as shown in Figure B-4.

Figure B-4 Configuration to Supply Multiple ATS

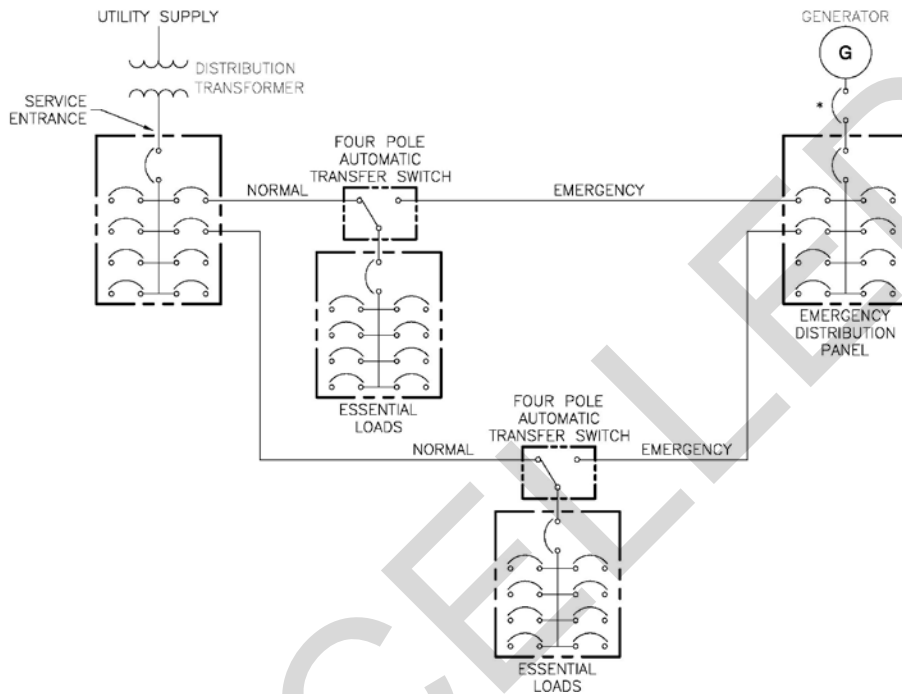

B-1.5 Single Engine Generator with Redundant Utility Supply.

If redundant utility sources are available, design the system to select either normal utility source with the generator as a backup if both utility sources fail. Figure B-5 provides an example.

Figure B-5 Selection Between Redundant Utility Supply and Generator

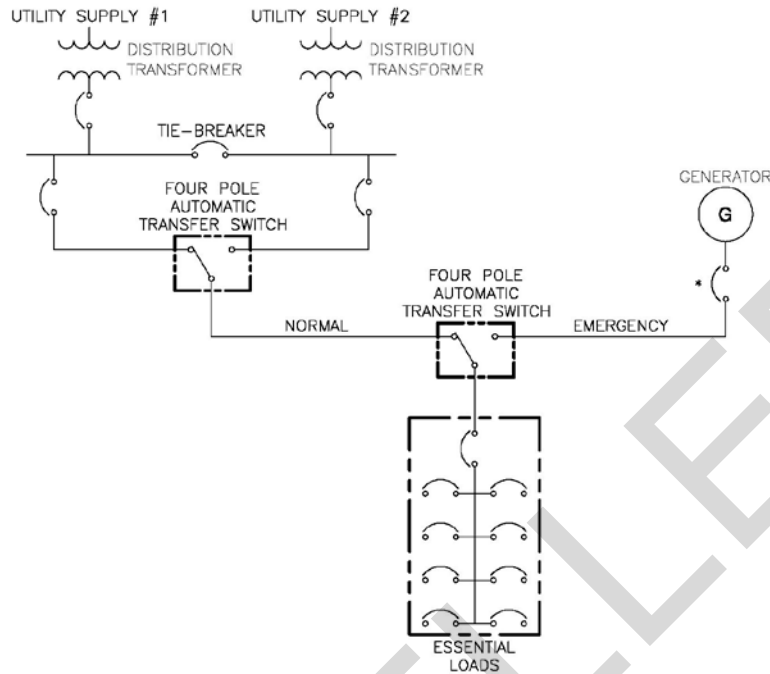

B-1.6 Dual Engine Generator with Redundant Utility Supply.

If redundant utility sources are available, design the system to select either normal utility source with the generator as a backup if both utility sources fail. If dual rather than parallel generators are provided, use an ATS to select between the generator supplies also. Figure B-6 provides an example.

Figure B-6 Selection Between Redundant Utility Supply and Dual Generators

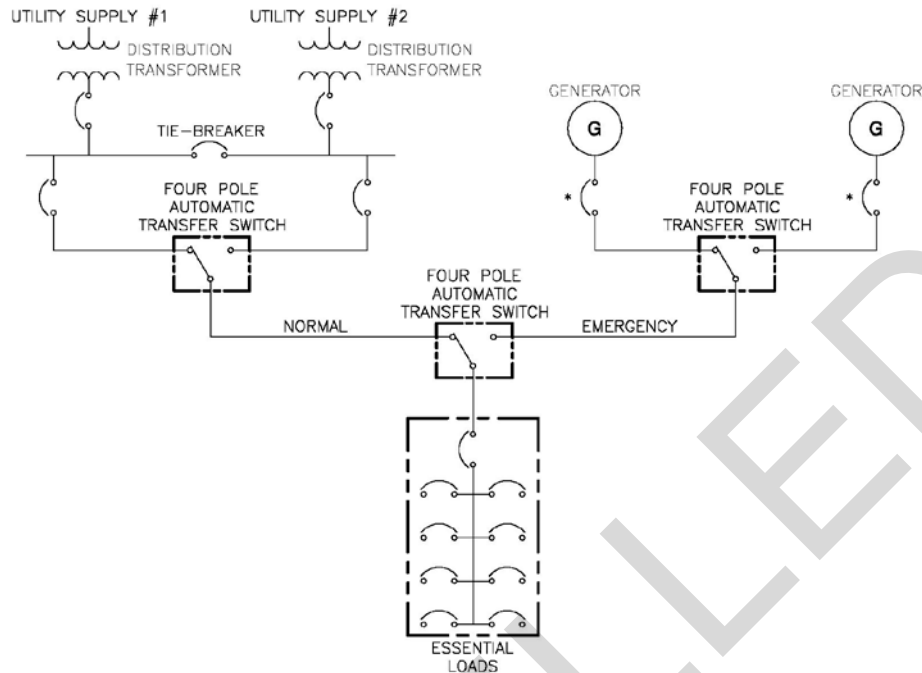

B-2 PARALLEL GENERATOR SYSTEM CONFIGURATIONS.

B-2.1 Utility Supply.

Parallel generators require the use of paralleling switchgear that results in a more complex operating system. Determine if a single utility supply (Figure B-7) satisfies reliability requirements. If additional system reliability is required, install an alternate commercial power supply as shown in Figure B-8. If feasible for the commercial power distribution system design, provide an alternate commercial power supply from a different source than the normal supply. Figure B-9 shows the preferred configuration if UPS systems are also supplied by alternate commercial and emergency power.

Figure B-7 Parallel Generators with Single Utility Supply

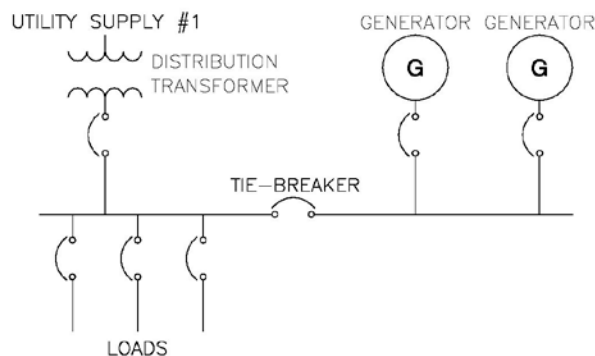

Figure B-8 Parallel Generators with Alternate Utility Supply

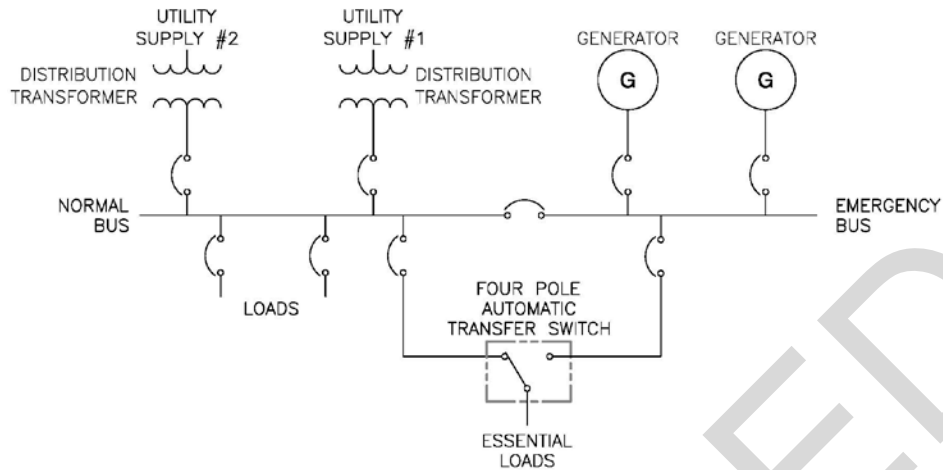
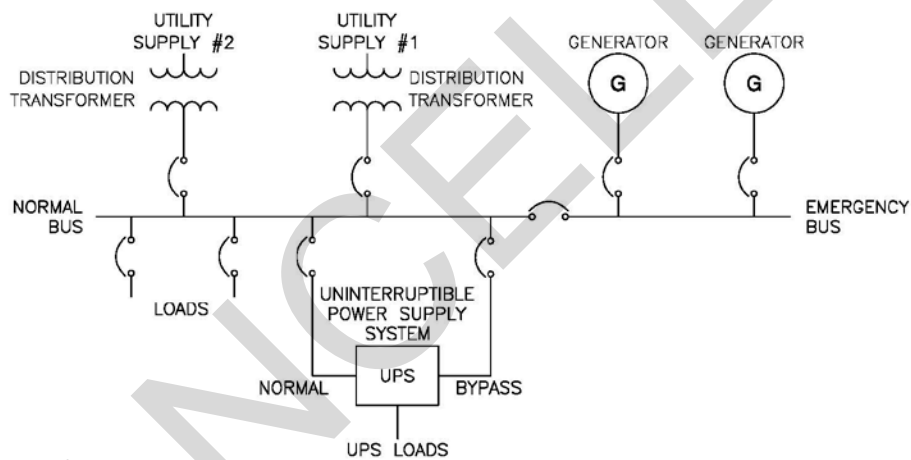

Figure B-9 Parallel Generators with Alternate Utility Supply for UPS Systems



B-2.2 Parallel Generator Control Systems.

Provide a redundant system in which any control system display can operate the control system. Design redundant programmable logic controllers (PLCs) for system control. A properly designed system can withstand a single failure and still operate. Figure B-10 shows an example of the control system architecture.

Figure B-10 Parallel Generator Control System Architecture

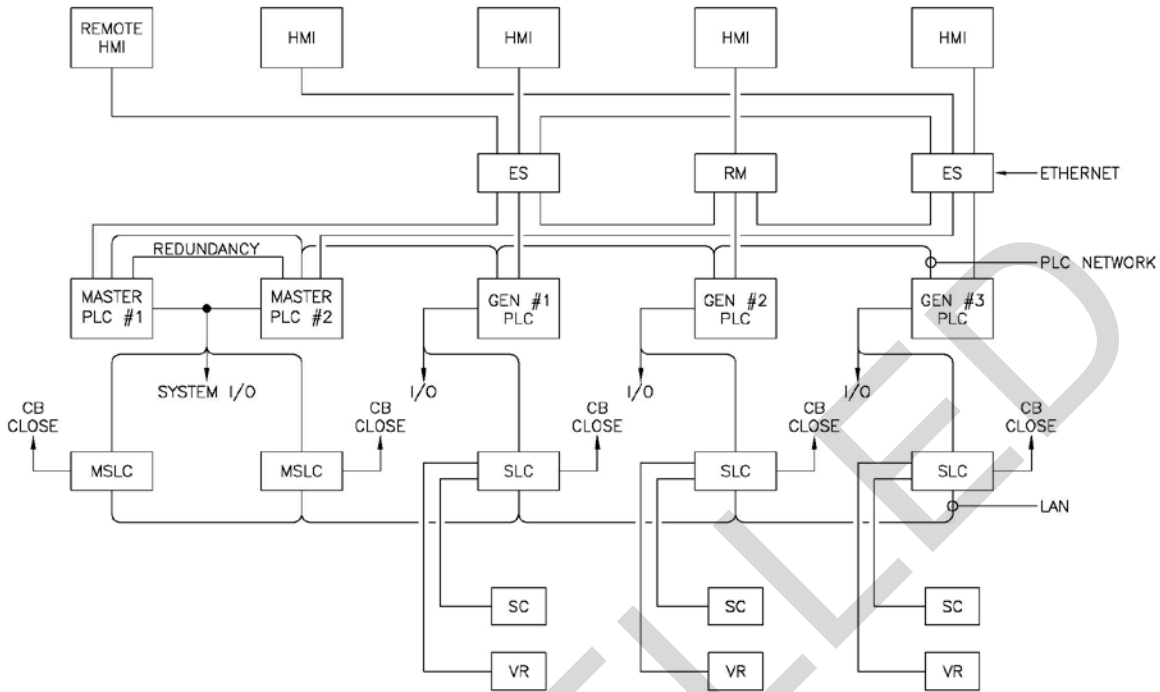

B-3 AUTOMATIC TRANSFER SWITCH CONFIGURATIONS.

Figure B-11 shows a simplified configuration with a four-pole ATS. For purposes of comparison, Figure B-12 shows a simplified configuration with a three-pole ATS.

Figure B-11 Typical Four-Pole ATS Arrangement

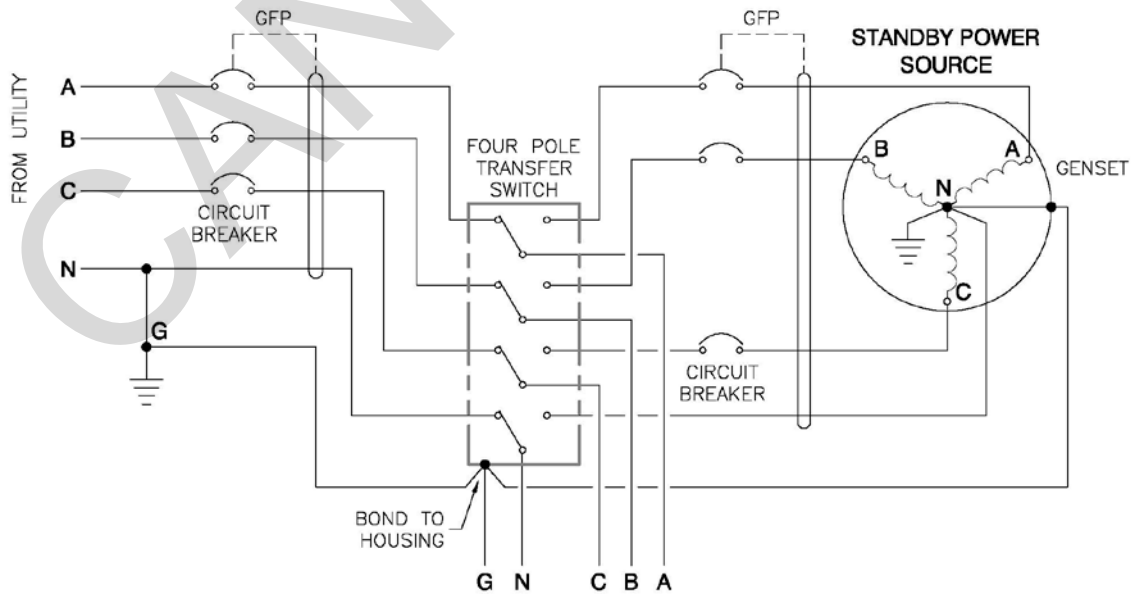
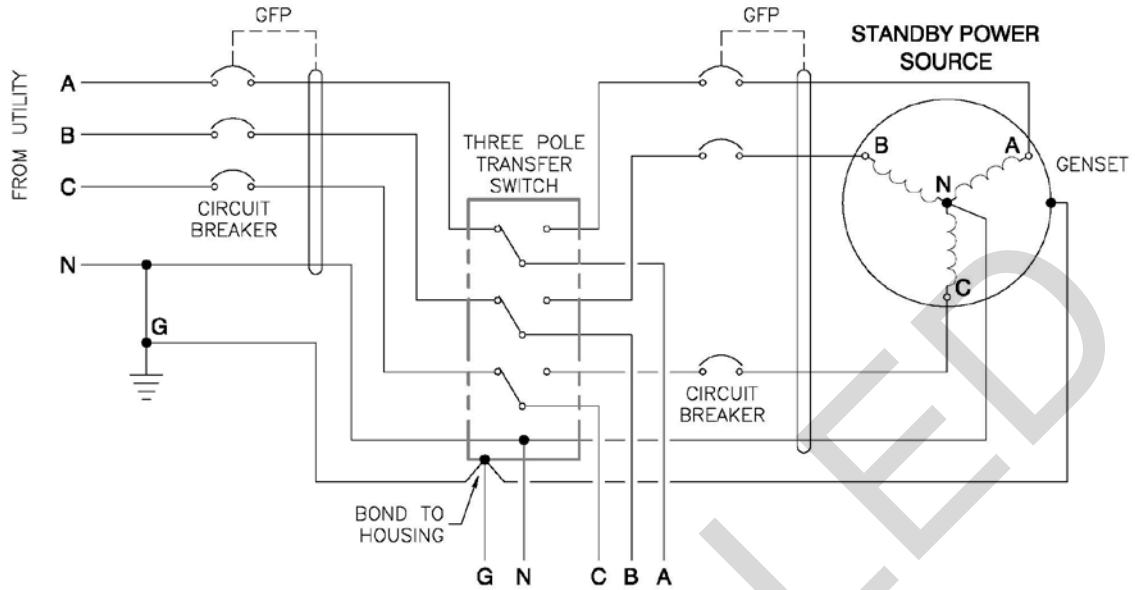

Figure B-12 Typical Three Pole ATS Arrangement



CANCELLED

APPENDIX C CHECKLIST

This appendix provides a design checklist of items to consider or address as part of the system design.

C-1 GENERAL.

A. Physical Space Requirements

1. Engine-generator dimensions.
2. Operation and maintenance space.
3. Cooling system space.
4. Fuel system space.
5. Ventilation (cooling air intake and exhaust).
6. Electrical panels, transfer switches, control panel spaces.
7. Exhaust system space and silencer location.
8. Starting system (electrical / air start).
9. Draw-out equipment requirements.

B. Power Rating – Continuous, prime, limited time running power, or emergency standby power.

C. Maximum time to start and be ready to assume load

(Emergency application consequences)

D. Emissions

1. Exhaust gas composition and particulate limits.
2. Noise limits.
3. Thermal emissions (air/water).
4. Fuel system constraints.

E. Generator Paralleling

1. Define sources.
2. Define configuration. Provide single-line diagram with the 35% design submittal.

C-2 ELECTRICAL.

A. Generator Sizing

1. Electrical load (kVA) – facility loads plus loads for fans, fuel pumps, lighting, battery charging, etc.

2. Motor starting kVA.
3. Nonlinear loads and effect on generator rating.
4. Power factor.
5. Engine-generator application – single set / parallel.
6. Frequency bandwidth (steady state).
7. Frequency regulation maximum – no load to full load.
8. Voltage regulation – no load to full load.
9. Voltage bandwidth – steady state.
9. Frequency – 50 / 60 Hz.
10. Voltage – output volts.
11. Phases – 3 phase, wye / delta, single phase.
12. Max step load increase – kVA.
13. Transient recovery time – seconds (voltage and frequency).
14. Maximum voltage deviation (transient).
15. Maximum frequency deviation – hertz.
16. Convenience duplex receptacles in generator room (for tools, testing, house-keeping).

B. Generator Protection

1. Subtransient reactance – percent (minimum).
2. Switchgear/breaker size, location, characteristics, enclosure.
3. Parallel generators – current transformers installed on neutral side of generator windings.

C. Automatic Transfer Switch

1. Sizing, controls, transfer options.
2. Coordination of ground fault protection (four-pole/three pole).
3. In-phase protection for large motors downstream of transfer switch.
4. Define sequence of operation “Upon loss of normal power...”. Define load shedding, motor starting sequence, if required, multiple generator operation, method of return to normal power (time delays), etc.

D. Starting System (Electric-Start)

1. Battery location – on skid.
2. Battery charger location.
3. Circuit size and routing.

4. Ventilation for battery charging.
5. Battery temperature limitations.

E. Starting System Controls

F. Generator Controls

G. Additional Circuits – coolant pumps, fuel transfer pumps, engine heaters, fuel heaters, piping heat-trace, cathodic protection, etc.

H. Grounding

1. Generator grounding - ungrounded, solidly-grounded, impedance-grounded.
2. Equipment grounding.
3. Building grounding and connections.
4. Surge arrester grounding.

I. Lighting

1. Equipment room normal lighting.
2. Equipment room alternate-source lighting.
3. Equipment room emergency lighting.
4. Outdoor enclosure lighting (access for controls).

J. Electrical Connections – connections with strain relief on power and communication connections to generator circuit breakers.

k. Load bank requirements for future testing.

C-3 MECHANICAL.

Evaluate system for compliance with NFPA 30, 37, and 110.

A. Engine

1. Installation elevation above sea level (derating).
2. Maximum speed (900 / 1200 / 1800 rpm).
3. Fuel consumption.
4. Starting system (air-start).
5. Ambient temperature extremes (HVAC, and/or derating).
6. Vibration limitations.
7. Ancillary equipment.

B. Fuel System

1. Main fuel tank (location, fill point, environmental requirements, cathodic protection) – UFC 3-460-01.
2. Day tank (space, location, shape, venting, NFPA 30 – capacity constraints, elevation relative to fuel injectors).
3. Fuel level controls.
4. Fuel transfer pump.
5. Supply line / return line routing.
6. Fuel coolers.
7. Fuel heaters.

C. Lube-Oil System

1. Integral to engine.
2. External to engine.
3. Space and provision for changing the oil.

D. Governor

1. Type: isochronous.
2. Frequency bandwidth (steady state).
3. Frequency regulation maximum – No load to Full Load.

E. Engine Cooling

1. Heat exchanger location (local/remote).
2. Cooling system design:
 - a. Local – Usually unit mounted radiator ducted through wall.
 - b. Remote heat exchanger – Usually requires expansion tank, pumps, piping, local heat exchanger, remote heat exchanger (radiator, cooling tower, etc.).
3. Maximum summer outdoor temperature (ambient).
4. Minimum winter outdoor temperature (ambient).
5. Cooling medium (glycol/water, raw water, etc.).

F. Engine Room Ventilation

1. Cooling - Maximum allowable heat transferred to engine generator space at rated output capacity.
2. Maximum summer indoor temperature (prior to generator operation)
3. Minimum winter indoor temperature (prior to generator operation)

4. Combustion air source (separate from cooling system).

G. Engine Controls (NFPA 37).

H. Exhaust System

1. Insulated/non-insulated).
2. Silencer (muffler location – inside /outside).
3. Penetration (roof/wall, location, thimble detail).
4. Multiple generating units - common exhaust considerations.
5. Exhaust considerations: flappers, gooseneck, bird-screen, rain shields.

I. Sound Limitations (OSHA, State, City Ordinances, Post/Base regulations)

1. Mechanical noise mitigation (interior/exterior).
2. Combustion-air intake noise mitigation (interior/exterior).
3. Exhaust noise mitigation (exterior).
4. Posting of signage - Hearing Protection Required.

J. Safety

1. Guarding of mechanical hazards.
2. Posting of signage for equipment which may auto-start.
3. Insulation of hot equipment.
4. Enclosure of electrical hazards.

C-4 CIVIL/STRUCTURAL.

- A. Seismic zone design.
- B. Vibration isolation.
- C. Foundation, house-keeping pads, etc.
- D. Grading, fuel tank installation.

C-5 ARCHITECTURAL.

- A. Building design, louvers, doors, etc.
- B. Bird screens for penetrations.
- C. Enclosure type – corrosion and high humidity location, desert environment.

CANCELLED

This Page Intentionally Left Blank

APPENDIX D GENERATOR SIZING

Appendix D discusses the input data required as part of a generator sizing calculation.

D-1 LOAD EVALUATION.

When specifying engine-generator sets, the designer will analyze the load characteristics and profiles of the load to be served to determine the peak demand, maximum step load increase and decrease, motor starting requirements (represented as starting kVA), continuous and non-continuous (cyclical/periodic), and the non-linear loads to be placed on the engine generator set. This information represents the essential elements that determine generator capacity and controls requirements. Engine generator set configuration is determined to some degree by characterization of the loads to be served and the interaction of that load with the engine generator set. Size, speed, allowable alternator temperature rise, and generator controls are all greatly affected by the character of the load to be served, and any of the above factors may determine generator sizing.

D-1.1 Uninterruptible, Essential, and Nonessential Loads.

As part of the backup power load analysis, classify each load as to the type of power that it should have. Determine which loads within the facility need to continue to function following a loss of normal power. Evaluate which loads must be uninterruptible, those to which power must be restored to perform an essential function (essential), or are not required for the facility/mission to function if the normal power source is interrupted (non-essential)

- Uninterruptible – Loads in this category require continuous power and cannot experience even momentary power disruptions. Loads in this category usually involve life safety or include hazardous or industrial process equipment, command, control, computer, data center, and communications systems. These loads will usually require the use of battery backup or an uninterruptible power system (UPS) to power them until supplied with power from an engine generator system.
- Essential – loads in this category require backup power, but can be deenergized until they can be supplied from an engine generator system. Loads in this category usually include HVAC loads to vital facilities or other load types that can be deenergized for short periods without severe consequence.
- Nonessential – loads in this category can be deenergized for extended periods without severe consequence. Although these loads might be classified as nonessential, they might still be capable of being energized from engine generators, depending on the facility design. For most systems, nonessential loads do not require generator backup.

D-1.2 Conditions of Loading.

Peak demand calculation provides one factor that determines the alternator size. Peak demand is the sum of continuous loads and non-continuous loads that are likely to be coincident.

- Continuous loads are energized for periods greater than 3 hours, such as lighting, UPS systems, and some HVAC equipment.
- Non-continuous loads do not meet the definition of continuous and the proportion of on to off time varies with each load.
- Coincident loads are those that are not prevented by character or controls from being energized at the same time.
- Non-coincident loads are dissimilar loads, fed from a common source that are prevented by character or controls from being energized at the same time. An example of a non-coincident load might be all compressors on an air conditioning chiller that are sequenced by a control system such that they do not operate simultaneously.

D-1.3 Nonlinear Loads.

Identify loads that are nonlinear. Non-linear loads are loads that draw a non-sinusoidal current waveform when supplied by a sinusoidal voltage source. Typical non-linear loads include solid state switching power supplies, computer power supplies (including those found in desktop PC's, uninterruptible power supplies, variable frequency drives, radar power supplies, and solid state ballasts in fluorescent light fixtures. These loads cause distortion of the source voltage and current waveforms that can have harmful effects on many types of electrical equipment and electronics, including generators. A low generator subtransient reactance minimizes the voltage waveform distortion in the presence of such loads. For this reason, when the non-linear loads comprise 25% or more of the loads served, the generator subtransient reactance should be limited to no more than 0.12.

Provide the assessment of the proportion of linear versus nonlinear loads to the generator supplier. Depending on the proportion of nonlinear loads, the generator supplier might recommend oversizing the generator, might modify the generator control system, or provide a generator with a lower subtransient reactance.

D-1.4 Step Loading.

Step load increase/decrease is used to account for the addition/loss of significant blocks of load. The significance of this is that the generator must be sized and controlled to maintain voltage and frequency within specific limits after sudden acquisition/loss of load (described as transient response). Establish the step loads that will be applied to or removed from the generator after startup. Some systems might apply all loads in a single step and other systems might establish multiple steps in order to limit the voltage and frequency transient during generator loading/unloading.

If the calculated generator size is based on transient response capability (control of voltage or frequency excursion from rated value) rather than peak load, consider load steps to reduce the amount of loads acquired at any single instant. Consider the following as part of the load analysis:

- Smaller generator systems will usually have a single automatic transfer switch (ATS) and all required loads will be energized at the same time.
- Larger generator systems might have multiple ATS, which can allow staggering of the load with discrete load steps.
- Some connected loads can have restart time delays independent of any ATS time delay.
- Parallel generator systems will usually have multiple ATS or distribution circuit breakers in the paralleling switchgear to establish step loading time delays.

D-1.5 Motor Starting Requirements.

Motor starting requirements are important to properly size engine generator sets because the starting current (inrush) for motors can be as much as six times the running current, and can cause generator output voltage and frequency to drop, even though the generator system has been sized to carry the running load. The designer must analyze the motor loads to determine if the starting characteristics of a motor or a group of motors to be started simultaneously will result in inadequate system performance.

Provide a motor starting kVA value for the largest motor or combination of motors to be started simultaneously. An increase in the size rating of the engine generator may be necessary to compensate for the inrush current. This information assists the engine generator supplier in properly sizing the engine generator set.

D-2 GENERATOR RATING.

The generator rating depends on the load analysis results, the projected annual and continuous run-time, and the overall system design and configuration.

D-2.1 Industry Ratings.

The generators addressed by this UFC will normally be rated based on their limited time running power classification (ISO 8528-1), which engine-generator manufacturers often refer to as the standby rating.

Apply the generator prime power rating for the installation if any of the following conditions apply:

- The expected annual operating time is longer than stated above, which might occur if the system will be used for utility peak shaving.

- The generator will be operating at near 100 percent of rating and the load is nonvarying. *Note: Historical experience indicates that most diesel generators will rarely be loaded near 100 percent and less than 50 percent loading is common.*
- The system is designated as a Critical Operations Power System (COPS) in accordance with NFPA 70 Article 708.

D-2.2 Generator Capacity Rating.

The required generator capacity depends on:

- Load analysis results; refer to paragraph D-1.1. Size the generator based on expected power demand rather than connected load.
- Magnitude of load steps that will be applied to the generator, together with the desired transient response characteristics.
- Allowable voltage and frequency variation, including initial loading effect.
- Oversizing to mitigate the effects of nonlinear loads. *Note: For combinations of linear and non-linear loads where the percentage of non-linear loads is small relative to the capacity rating of the generator (25% or less), standard generator configurations are normally acceptable.*

Small generators with a relatively simple load analysis can be sized by hand calculations. Larger generator systems with a large proportion of nonlinear loads or multiple load steps will require software specifically designed for generator sizing. Generator suppliers can provide this software or will perform the calculations.

D-2.3 Uninterruptible Power Supply (UPS) Systems.

UPS systems can have a detrimental effect on generator control systems and need to be considered in the generator performance requirements and generator commissioning. Ensure the following are addressed in the design:

- Generator and UPS communication so that the UPS recognizes when it is operating on a generator.
- Allowed battery charging current while the UPS operates on a generator source. UPS battery charging is not considered a critical/mission-essential load during generator operation and should be reduced to the minimum allowed by the UPS design, if it is an available UPS design feature.
- Power walk-in – limit the rate at which the UPS transfers from its internal battery to the generator, if available in the UPS design.

- UPS input filter energized only after adequate load is established. Generator sets inherently have difficulty controlling voltage with leading power factors, which can cause an increasing voltage as the voltage regulator attempts to control voltage. This condition can be exacerbated during UPS start-up by the power walk-in feature. Typically, a UPS has some means of gradually applying load to the source over a 3 to 60 second period. An unloaded input filter may cause a leading capacitive power factor load beyond the generator's voltage control ability. Other loads connected to the generator will counter this effect. Also, disconnecting the filter at lower UPS loads will minimize this effect. This is an essential design requirement.
- Rotary UPS on DC bus – limit the rotary recharge rate when the UPS is operating on generator.
- If the system has step loading capability, energize nonlinear loads such as a UPS after other mechanical-type loads have been energized.

Ensure the engine generator commissioning process confirms acceptable operation of the fully connected system with the UPS systems in service.

D-2.4 Power Quality.

The load analysis described in paragraph D-1 requires an assessment of the proportion of linear versus nonlinear loads. Nonlinear loads can adversely affect the generator control system. Provide this information to the generator supplier for evaluation.

Ensure the engine generator commissioning process confirms acceptable operation of the fully connected system with the nonlinear loads in service. If power factor correction capacitors are installed, ensure they are energized during the commissioning process if they are to remain in service.

CANCELLED

This Page Intentionally Left Blank

APPENDIX E CONNECTION METHODS FOR PORTABLE GENERATORS

E-1 INTRODUCTION.

This appendix provides information regarding the use of NFPA 70, UL-listed, CSA-certified, double-locking, single pole connectors (Cam-Lok style) or MIL C-22992, Class L, QWLD-rated multiple cylindrical pin connectors (Cannon plug) as quick connection/disconnection means for portable generator connections of 600 volts or less for facilities. This is the typical Air Force connection method for portable generators.

Portable generators are referred to as standby generators within the Air Force and are classified as equipment authorization inventory data (EAID) generators.

E-2 CONNECTION METHODS.

Generator facility connections must either be hardwired or utilize connection methods as noted below.

E-2.1 MIL-C-22992, Class L, QWLD-Rated Connectors.

Heavy-duty cylindrical, MIL-C-22992, Class L, QWLD-rated connectors (Cannon plug) with appropriately rated disconnect switch selected in accordance with NFPA 70 are permitted as follows:

- Up to three (3) connections per generator are permitted. The maximum single connector rating must be 200 amperes. Mobile Electric Power (MEP) 6/806 units are permitted to utilize a single 200A Cannon plug connection.
- The combined loads from multiple connections must not exceed the rated capacity of the standby generator.
- The single conductor size used in any connector must not exceed #4/0 American Wire Gauge (AWG).
- Unused connector receptacles must be capped with manufacturer-recommended covers to prevent exposure to live electrical contacts. Plastic dust caps are not acceptable.
- A data plate style placard must be permanently attached, using sheet metal screws or rivets, adjacent to the connection(s), which reads:

DANGER
UNUSED CONNECTOR RECEPTACLES ARE ENERGIZED DURING
GENERATOR OPERATION.
EXERCISE EXTREME CAUTION.
PROPER PPE REQUIRED WHEN MAKING CONNECTIONS

- Cable assemblies connected in parallel must comply with all of the following:
 - Be the same length.
 - Have the same conductor material.
 - Be the same size in circular mil area.
 - Have the same insulation type, including cable assembly sheathing.
 - Be terminated in the same manner and be of the same rating. For example, a 200-ampere connection cannot be paralleled with a 60-ampere connection even though the cable assemblies are rated for 200 amperes.
- All operators must be trained on the danger associated with multiple connections on the generator bulkhead. Supervisors must document this training.

E-2.2 Single-Pole (Cam-Lok style) Connectors.

Single-pole (Cam-Lok style) connectors and receptacles that are double locking in accordance with the NEC and NEMA 3R rated are permitted with limitations. For standby generators, paralleled connections are prohibited. A single connector per phase must be used for each load and meet the following requirements (Note: MEP 6/806 units are permitted to utilize a single 200-ampere Cam-Lok style connector/plug connection per phase.):

- Connectors and receptacles must be rated 200 amperes or less, UL listed and CSA certified.
- Connector and receptacle contacts must be made of high-conductivity copper base alloy.
- Connector and receptacle must provide a double-locking means to ensure a minimum 600 lb/in² pressure on contact.
- Connector contacts must be recessed. A thermoplastic rubber or neoprene-insulated jacket must extend past the ends of both the male and female contacts and meet the strain relief requirements listed below.
- Receptacles must be provided with NEMA 3R color-coded (for phase and ground identification) snap-back covers (150 amperes and less) or protective caps.
- Cable plugs must be provided with color-coded (for phase and ground identification) protective caps with lanyards.
- Tapping tees are not permitted.

- Connectors and cable plugs must be fully rated for intended use.
- Cable-to-plug connections must be crimped. Set-screw connection means are not allowed because of their tendency to loosen due to heating/cooling, high load, and vibration.
- The only approved cable strain relief means is vulcanized style terminations.

Up to three (3) Cam-Lok style connectors (max twelve [12] single-phase connectors) per generator are permitted to allow connection to three separate loads. The maximum single connector rating must be less than 200 amperes.

CANCELLED

CANCELLED

This Page Intentionally Left Blank

APPENDIX F FACILITY DESIGN TYPES

Appendix F discusses different facility design types that might be authorized to have a backup power system.

For Army applications, each major command/program defines its standby and emergency power requirements based on mission requirements, location/environmental parameters, and the NFPA criteria (life-safety). Typical applications that require standby or emergency power include: Command, Control, Communications, Computers (Data Centers), health care, industrial process facilities, RDT&E Facilities, Laboratories, and Installation Critical Support Services (including force protection, readiness, community support).

For Air Force applications, generator authorizations are defined in Engineering Technical Letter (ETL) 13-4: *Standby Generator Design, Maintenance, and Testing Criteria*.

For Navy applications, Table F-1 provides a list of the types of facilities that are typically authorized to have emergency generators. This information was obtained from UFC-000-05N, *Facility Planning for Navy and Marine Corps Shore Installations*, and is not considered a complete list; it only contains the occurrences in UFC-000-05N where generators are mentioned.

For various Tri-Service applications, Table F-2 provides a summary of facilities that are authorized to have emergency power. This information was obtained from UFCs.

Table F-1 Naval Facilities Authorized for Backup Power

Category Code	Facility Type	Comments
12330	Vehicle and Equipment Ready Fuel Storage	Authorized for buildings and utilities that may be needed in a hurricane or other base emergency.
13120	Communications Relay Facility	Contains rack mounted communications receiving, amplification, and transmitting equipment, along with an Uninterruptible Power Source (UPS) and an Emergency Generator.
13122	VHF/UHF Communications Facility	Contains a small UPS and an emergency generator.
13135	Receiver Building	Contains a UPS and an emergency generator.
13140	Telephone Exchange Building	Can contain the telephone switch, main distribution frame, intermediate distribution frame, staff support spaces, operators work positions, maintenance and storage spaces, and is supported by UPS and emergency generators.
13150	Transmitter Building	Contains a UPS and an emergency generator.
13372	Military Terminal Radar Approach Control Facility	Space is provided in the mechanical room for an emergency generator and UPS system.
13373	Fleet Area Control Surveillance Facility	The mechanical space should include sufficient room for as emergency generator and a UPS system.
13374	Joint Control Facility	The mechanical spaces should include sufficient space for an emergency generator and UPS system.
13375	Air Surveillance Radar (ASR) Facility	The building and its associated antenna tower are located in a remote area of the airfield and an access road and emergency generator are required.
14365	Operations Control Center	UPS and emergency generators are required for continuous operation during natural disasters and increased security postures.

Category Code	Facility Type	Comments
14380	Command, Control, Communications, Computers, and Intelligence Facility (C4I)	The technical and operational mission of a C4I will require that it contain, Secure Compartmented Information Facility (SCIF) areas, a UPS, emergency generators, and in selected cases, Radio Frequency Interference (RFI) shielding, Electromagnetic Interference (EMI) shielding, and Telecommunications Electronics Material Protected from Emanating Spurious Transmissions (TEMPEST) protection
14385	Joint Reserve Intelligence Center (JRIC)	The technical and operational mission of a JRIC will require that it contain, SCIF areas, a UPS, emergency generator(s), and in selected cases, RFI shielding, EMI shielding, and TEMPEST protection.
51010	Hospital	Stand-by/ emergency electrical generation, operational fuel storage of the generators or building heat systems and electrical transformers in direct support of the medical facilities should have the BUMED activity as the User and Maintenance UIC. The BUMED facility is not a complete and useable facility without the inclusion of these directly supporting utility systems.
81159	Standby Generator Building	Standby generators are used to provide electrical power when the normal source of power is not available. This category includes all necessary equipment for the production of the commodity, including tanks, pumps, electrical equipment, and all other equipment for electrical generation.
81160	Standby Generator Plant	Standby generators are used to provide electrical power when the normal source of power is not available. This category includes all necessary equipment for the production of the commodity, including tanks, pumps, electrical equipment, and all other equipment for electrical generation.

Table F-2 UFCs Addressing Backup Power Requirements

UFC	Title	Requirement Summary
4-133-01N	Navy Air Traffic Control Facilities	Requires emergency generators for various facility types, including radar air traffic control facilities (RATCF), fleet area control and surveillance facility (FACSFAC), joint control facility (JCF), and air traffic control tower (ATCT).
4-141-04	Emergency Operations Center Planning and Design	When required, only essential systems should be placed on the emergency system with a generator being the primary emergency power source. The type, size and number of generators is based on the operational requirements of the EOC.
4-141-10N	Design: Aviation Operation and Support Facilities	UFC 4-141-10N issues MIL-HDBK-1024/1, Aviation Operational and Support Facilities, for use for Navy applications. Requires emergency generators for a variety of aviation operation and support facilities.
4-150-02	Dockside Utilities for Ship Service	Requires standby power for nuclear submarines.
4-211-01N	Aircraft Maintenance Hangars: Type I, Type II, and Type II	Coordinate and provide emergency power as dictated by the mission. At a minimum, hangar doors must be operable in the event of utility power failure by means of a generator.
4-213-10	Graving Drydocks	Install a back-up emergency diesel generator near each pumphouse to run at least the drainage pumps and alarms in the event all electrical power is lost
4-510-01	Design: Medical Military Facilities	Requires emergency generators for hospitals.
4-722-01F	Air Force Dining Facilities	AFI 32-1063, "Electric Power Systems", authorizes an emergency generator for one feeding facility per installation, with MAJCOM having authority to approve additional eating facilities.
4-722-01N	Navy and Marine Corps Dining Facilities	Provide facility service entrance with the capability to temporarily connect a portable generator, via an external connection point. Systems utilizing portable generators must comply with NFPA 70 Article 702, Optional Standby Systems. If the facility has been designated as a Mass Care feeding facility, provide a permanent, external self-contained emergency generator that must power the entire facility load. Provide 72 hours of fuel storage.

UFC	Title	Requirement Summary
4-730-04AN	Military Police Facilities	<p>Auxiliary Support Power Back-up power may be provided as auxiliary support by individual battery units, a central battery system or by an engine-generator set. Determination of the type of auxiliary support provided will be based upon economics alone.</p> <p>Special requirements exist for an automatic emergency source or power for critical communications, surveillance security systems using monitoring devices (CCTV I D alarms, etc.) linked to the MP desk and for other special equipment or functional areas where power outage would jeopardize mission-effectiveness.</p>
4-730-10	Fire Stations	<p>Provide 100% emergency generator back-up power for HQ/Main and Large HQ stations. For Satellite stations, provide emergency back-up power, at a minimum, for the following spaces/systems:</p> <ul style="list-style-type: none"> • Apparatus Bay lighting and doors, • Watch Desk/Dispatch and all associated equipment, • IT Room systems related to the Dispatch and communication functions, • Lighting. <p>If required by Installation mission requirements, consider providing emergency power for additional spaces, such as the Day Room, or providing 100% emergency back-up power for the entire Satellite station.</p>

UFC	Title	Requirement Summary
4-470-02N	Navy and Marine Corps Fitness Centers	<p>Provide facility service entrance with the capability to temporarily connect a portable generator, via an external connection point.</p> <p>Systems utilizing portable generators must comply with NFPA 70 Article 702, Optional Standby Systems. Coordinate with activity representatives to develop a written, manual load-shedding procedure for the facility. Document size of generator required to support design conditions.</p>

CANCELLED

APPENDIX G GLOSSARY

G-1 ACRONYMS

A	Amperes
AC	Alternating Current
AFCEC	Air Force Civil Engineer Center
AFI	Air Force Instruction
AHJ	Authority Having Jurisdiction
ATS	Automatic Transfer Switch
AWG	American Wire Gauge
CE	Civil Engineering
COPS	Critical Operations Power Systems
CT	Current Transformer
DC	Direct Current
EAID	Equipment Authorization Inventory Data
EPA	Environmental Protection Agency
EPSS	Emergency Power Supply System
Ft	Feet
HVAC	Heating, Ventilating, and Air Conditioning
Hz	Hertz
IEEE	formerly Institute of Electrical and Electronics Engineers
kVA	Kilo-Volt-Amperes
kW	Kilowatt
NAVFAC	Naval Facilities
NEMA	National Electrical Manufacturers Association
NFPA	National Fire Protection Association
RPIE	Real Property Installed Equipment

rpm	Revolutions per Minute
TBD	To Be Determined
THD	Total Harmonic Distortion
UFC	Unified Facilities Criteria
UL	Underwriters Laboratories
UPS	Uninterruptible Power Supply
USACE	U.S. Army Corps of Engineers
V	Volts

CANCELLED

G-2 DEFINITION OF TERMS

Automatic Transfer Switch (ATS) – A switch designed to sense the loss of one power source and automatically transfer the load to another source of power.

Availability: The long-term probability of success with repair and scheduled maintenance of electrical power plants, generators, and power systems. Calculate availability as the ratio in percentage of total period minus repair downtime minus maintenance downtime to total period. The calculation assumes power generated meets quality standards.

Closed Transition Switch: Transfer switch that provides a momentary paralleling of both power sources during a transfer in either direction. The closed transition is possible only when the sources are properly interfaced and synchronized.

Critical Operations Power Systems: Systems that are installed in vital infrastructure facilities that, if destroyed or incapacitated, would disrupt national security, the economy, public health or safety; and where enhanced electrical infrastructure for continuity of operation has been deemed necessary by governmental authority. COPS design criteria are specified by NFPA 70 Article 708.

Emergency Systems: As specified by NFPA 70, emergency systems are those systems legally required and classed as emergency by municipal, state, federal, or other codes, or by any governmental agency having jurisdiction. These systems are intended to automatically supply illumination, power, or both, to designated areas and equipment in the event of failure of the normal supply or in the event of accident to elements of a system intended to supply, distribute, and control power and illumination essential for safety to human life.

Harmonic: A sinusoidal component of a periodic wave or quantity having a frequency that is an integral multiple of the fundamental frequency.

Legally Required Standby Systems: Those systems required and so classed as legally required standby by municipal, state, federal, or other codes or by any governmental agency having jurisdiction. These systems are intended to automatically supply power to selected loads (other than those classed as emergency systems) in the event of failure of the normal source.

Linear Load: An electrical load device that presents an essentially constant load impedance to the power source throughout the cycle of applied voltage in steady-state operation.

Listed: Applies to equipment or materials included in a list published by an organization acceptable to the authority having jurisdiction. The organization periodically inspects production and certifies that the items meet appropriate standards or tests as suitable for a specific use.

N+1: A reliability term indicating that if a total of n units are installed, an additional unit is installed to ensure system reliability in the event of a single unit failure or to accommodate other activities such as periodic maintenance.

Nonlinear Load: A steady state electrical load that draws current discontinuously or has the impedance vary throughout the input ac voltage waveform cycle. Alternatively, a load that draws a nonsinusoidal current when supplied by a sinusoidal voltage source.

Optional Standby Systems: Those systems intended to supply power to public or private facilities or property where life safety does not depend on the performance of the system. Optional standby systems are intended to supply on-site generated power to selected loads either automatically or manually.

Power Quality: The concept of powering and grounding sensitive equipment in a manner that is suitable to the operation of that equipment.

Transfer Switch: A device for transferring one or more load conductor connections from one power source to another.

Uninterruptible Power Supply System: A system that converts unregulated input power to voltage and frequency controlled filtered ac power that continues without interruption even with the deterioration of the input ac power.

CANCELLED