

UNIFIED FACILITIES CRITERIA (UFC)

STATIONARY BATTERY AREAS



STATIONARY BATTERY AREAS

Any copyrighted material included in this UFC is identified at the point of use. Use of the copyrighted material apart from this UFC must have the permission of the copyright holder.

NAVAL FACILITIES ENGINEERING COMMAND (Preparing Activity)

U.S. ARMY CORPS OF ENGINEERS

AIR FORCE CIVIL ENGINEER SUPPORT AGENCY

Record of Changes (changes are indicated by \1\ ... /1/)

Change No.	Date	Location

FOREWORD

The Unified Facilities Criteria (UFC) system is prescribed by MIL-STD 3007 and provides planning, design, construction, sustainment, restoration, and modernization criteria, and applies to the Military Departments, the Defense Agencies, and the DoD Field Activities in accordance with [USD\(AT&L\) Memorandum](#) dated 29 May 2002. UFC will be used for all DoD projects and work for other customers where appropriate. All construction outside of the United States is also governed by Status of forces Agreements (SOFA), Host Nation Funded Construction Agreements (HNFA), and in some instances, Bilateral Infrastructure Agreements (BIA.) Therefore, the acquisition team must ensure compliance with the more stringent of the UFC, the SOFA, the HNFA, and the BIA, as applicable.

UFC are living documents and will be periodically reviewed, updated, and made available to users as part of the Services' responsibility for providing technical criteria for military construction. Headquarters, U.S. Army Corps of Engineers (HQUSACE), Naval Facilities Engineering Command (NAVFAC), and Air Force Civil Engineer Support Agency (AFCESA) are responsible for administration of the UFC system. Defense agencies should contact the preparing service for document interpretation and improvements. Technical content of UFC is the responsibility of the cognizant DoD working group. Recommended changes with supporting rationale should be sent to the respective service proponent office by the following electronic form: [Criteria Change Request \(CCR\)](#). The form is also accessible from the Internet sites listed below.

UFC are effective upon issuance and are distributed only in electronic media from the following source:

- Whole Building Design Guide web site <http://dod.wbdg.org/>.

Hard copies of UFC printed from electronic media should be checked against the current electronic version prior to use to ensure that they are current.

AUTHORIZED BY:

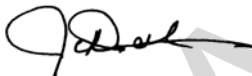

JAMES C. DALTON, P.E.
Chief, Engineering and Construction
U.S. Army Corps of Engineers



PAUL A. PARKER, P.E.
The Deputy Civil Engineer
DCS/Installations & Logistics
Department of the Air Force



JOSEPH E. GOTT, P.E.
Chief Engineer
Naval Facilities Engineering Command

EMAIL CONFIRMATION

CAPT Paz Gomez, USN, P.E.
Acting Director, Installations Requirements and
Management
Office of the Deputy Under Secretary of Defense
(Installations and Environment)

**UNIFIED FACILITIES CRITERIA (UFC)
NEW DOCUMENT SUMMARY SHEET**

Document: 3-520-05, Stationary Battery Areas

Superseding: None

Description: This UFC 3-520-05 provides design guidance for the design of stationary battery installations.

Reasons for Document:

- Provide technical requirements for enclosed battery areas.
- Address multi-discipline requirements for battery room layout and design. This document addresses architectural, electrical, mechanical, civil, fire protection, and plumbing requirements.
- Incorporate new and revised industry standards.

Impact: There are negligible cost impacts associated with this UFC. However, the following benefits should be realized.

- Standardized guidance has been prepared to assist engineers with the unique installation requirements for battery systems.
- Over design of battery areas should be avoided by ensuring that industry standard guidance is preferentially applied.
- Safety requirements associated with batteries are addressed.

CONTENTS

	<u>Page</u>
CHAPTER 1 INTRODUCTION.....	1
1-1 PURPOSE.....	1
1-2 SCOPE.....	1
1-3 EXCLUSIONS.....	1
1-4 APPLICATION.....	2
1-4.1 Installations.....	2
1-4.2 Facilities.....	2
1-4.3 Conflicts.....	2
1-4.4 Compliance.....	2
1-5 SAFETY.....	2
1-6 REFERENCES.....	2
CHAPTER 2 DESIGN CRITERIA.....	3
2-1 GENERAL.....	3
2-2 ARCHITECTURAL REQUIREMENTS.....	3
2-3 MECHANICAL REQUIREMENTS.....	6
2-4 ELECTRICAL REQUIREMENTS.....	7
2-5 EMERGENCY FACILITIES.....	8
2-6 FIRE PROTECTION REQUIREMENTS.....	8
GLOSSARY	9
APPENDIX A REFERENCES	11
APPENDIX B SAMPLE VOLUMETRIC FLOW RATE CALCULATION.....	14
APPENDIX C STATIONARY BATTERY APPLICABILITY	16

FIGURES

Figure 2-1. Two-Step Battery Rack Configurations (End View).....	4
Figure 2-2. Larger Battery Rack Configurations (End View).....	5

TABLES

Table 2-1. Battery Rack Requirements by Seismic Design Category	5
---	---

CHAPTER 1 INTRODUCTION

1-1 PURPOSE.

Unified Facility Criteria (UFC) 3-520-05 provides design guidance for stationary secondary battery installations. It serves as a planning, engineering, and design reference for professional facility planners, designers, and constructors, including DoD personnel and Government contractors. Designers and planners will use this document for individual project planning, for preparing engineering documentation, and for preparing contract documents for construction and renovation projects.

1-2 SCOPE.

This UFC cites and supplements existing Government and commercial standards and specifications governing the architectural, mechanical, plumbing, and electrical requirements for design of stationary secondary battery installations. These batteries are operated on a continuous float charge and require ventilation to limit hydrogen gas concentrations.

Note: The additional requirements identified in MIL-HDBK 411B, Power and the Environment for Sensitive DoD Electronic Equipment, can apply to larger battery installations, such as for fixed Department of Defense (DoD) communications, data processing, and information systems facilities. However, this UFC has more stringent criteria with respect to hydrogen control, and conforms with current industry practices and standards (single fan versus dual fan criteria). Therefore, MIL-HDBK 411B is no longer required with respect to battery area design.

1-3 EXCLUSIONS.

Design of primary battery installations, mobile applications of secondary batteries, and battery maintenance facilities are not covered by this UFC.

For Navy projects, see UFC 4-229-01N, *Design: General Maintenance Facilities*, and UFC 3-410-04N, *Design: Industrial Ventilation*, for design criteria relating to the design of facilities for battery maintenance and repair.

Stationary battery installations, regardless of size, designed as part of a manufacturer's equipment and contained within one or more enclosures furnished as part of that equipment are also excluded, provided that the enclosing room (if any) meets all of the battery manufacturer's minimum requirements for ventilation and temperature control.

Appendix C provides examples of battery installation types that are covered by this UFC.

1-4 APPLICATION.

1-4.1 Installations.

Stationary battery installations, where required by NFPA 70E Article 320.4 (2004 Edition), shall be installed in a battery enclosure or battery room meeting the requirements of this UFC.

1-4.2 Facilities.

Criteria in this UFC apply to DoD owned or leased facilities located on or outside of DoD installations, whether acquired by appropriated or non-appropriated funds, or third party financed and constructed. Facilities include all temporary or permanent structures independent of their size.

1-4.3 Conflicts.

If a conflict exists between this UFC and any other DoD document, referenced code, standard, or publication, this UFC takes precedence.

1-4.4 Compliance.

Comply with the design criteria of this UFC for new construction and major renovation projects. For Air Force projects, comply with any additional criteria of AFPAM 32-1186, *Valve-Regulated Lead acid Batteries for Stationary Application*. Renovation of existing battery installations solely for the purpose of meeting the design criteria of this UFC is not required. Where existing conditions present a hazard to personnel, that hazard shall be immediately remedied by renovation in accordance with the applicable section of this UFC. Apply the criteria in this UFC for retrofits of existing installations.

1-5 SAFETY.

Comply with UFC 3-560-01, *Electrical Safety, O&M*, and NFPA 70E, *Standard for Electrical Safety in the Workplace*, Article 320, for battery-related electrical safety requirements. EM 385-1-1, *Safety and Health Requirements*, and OSHA 1926.441 also apply to this UFC.

1-6 REFERENCES.

Appendix A contains a complete list of references used in this manual. The publication date of the referenced code or standard is included in this list. In general, and when the publication date is not given, the latest available issuance of the reference shall be used.

CHAPTER 2 DESIGN CRITERIA

2-1 GENERAL.

2-1.1 Comply with NFPA 70, *National Electrical Code* (NEC), and NFPA 70E Article 320.6 (2004 Edition) for battery room design requirements.

2-1.2 Comply with the recommendations of UFC 3-520-01, *Design: Interior Electrical Systems*, for battery selection, sizing, and application.

2-1.3 Regulatory requirements and restrictions vary depending upon location. Battery installations may require permits and environmental control and reporting due to their component heavy metals and acidic or basic electrolyte. Consult Title 29 Code of Federal Regulations (CFR) Parts 1910 and 1926 *Occupational Safety and Health Standards*, Title 40 Code of Federal Regulations *Protection of Environment*, and other applicable regulations for additional information.

2-2 ARCHITECTURAL REQUIREMENTS.

2-2.1 Locate the battery near the loads to be served while still satisfying the mechanical design criteria.

2-2.2 Provide the occupancy separation requirements specified in NFPA 1, *Uniform Fire Code*. When more than one battery chemistry is employed, each type of battery shall be located in a separate room with each room individually meeting the occupancy separation requirements and with no direct access between the rooms. Services not associated with the battery room shall not pass through the room. The battery room shall not be used for access to other spaces. Battery rooms shall not be used for material storage, such as storage of office supplies, cleaning supplies, or spill control equipment; design a separate space for these materials.

2-2.3 Provide battery enclosures that are a commercial manufactured product, designed and UL listed for battery containment. Provide a minimum 200 mm (8 in.) working clearance around the batteries within the enclosure. For outside installations prevent entry of contaminants, water, insects, and wildlife.

2-2.4 Provide spill control for battery installations as required by NFPA 1. An electrolyte spill is defined as an unintended release of liquid electrolyte that exceeds 1.0 liters. Battery enclosures that do not provide integral spill containment shall not be used. Permanently installed physical containment structures shall be capable of resisting continuous exposure to a 70 percent concentration of the electrolyte's acid or alkaline chemical. The containment area shall not encroach upon space designated for room egress.

Note: Valve-regulated lead acid (VRLA) batteries have the electrolyte immobilized in a gel or absorbent glass mats. The immobilization limits the potential release of electrolyte to much less than the definition of a spill. For this reason, VRLA designs do not require permanently installed spill containment systems. Electrolyte releases from

VRLA batteries, while small, can occur and the necessary supplies for manual cleanup should be available in the battery area.

2-2.5 Provide for spilled electrolyte neutralization in accordance with NFPA 1. Provide neutralizing and absorbing materials local to, but outside of, the battery area to address local incidents.

2-2.6 Floor finish in all battery rooms and enclosures shall be slip-resistant and acid or alkali resistant as appropriate for the battery chemistry employed. Wall and ceiling finishes in vented (flooded) cell installations shall be acid or alkali resistant.

2-2.7 Obtain the battery rack from the same manufacturer that supplies the battery. Racks and trays shall resist corrosion from continuous exposure to a 70 percent concentration of the electrolyte's acid or base chemical. Battery lifting devices shall be insulated and tools shall be provided with insulated handles.

2-2.7.1 Select the battery rack to fit within the defined footprint while also satisfying the need for maintenance access. Figures 2-1 and 2-2 show acceptable battery rack configurations for vented cells.

Figure 2-1. Two-Step Battery Rack Configurations (End View)

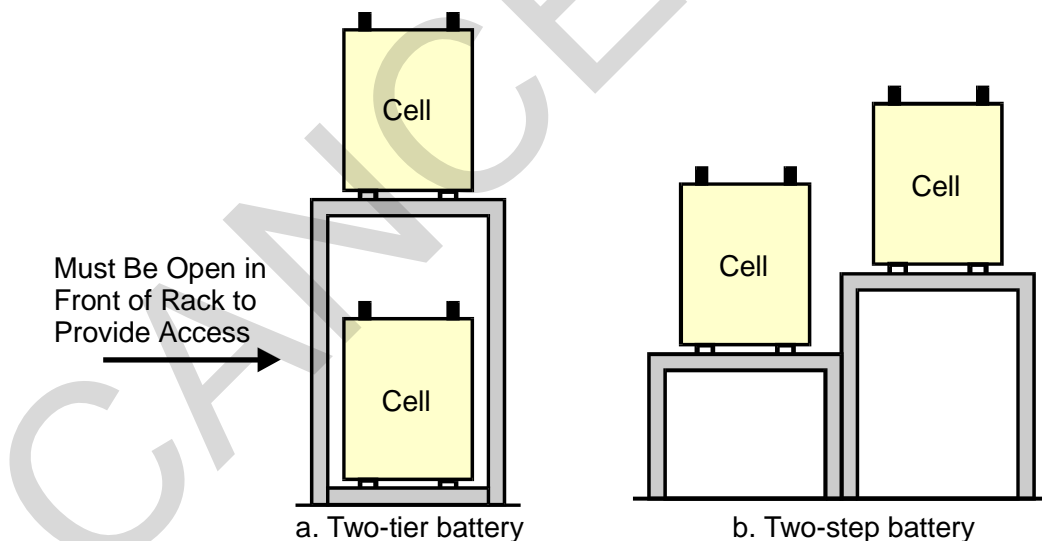
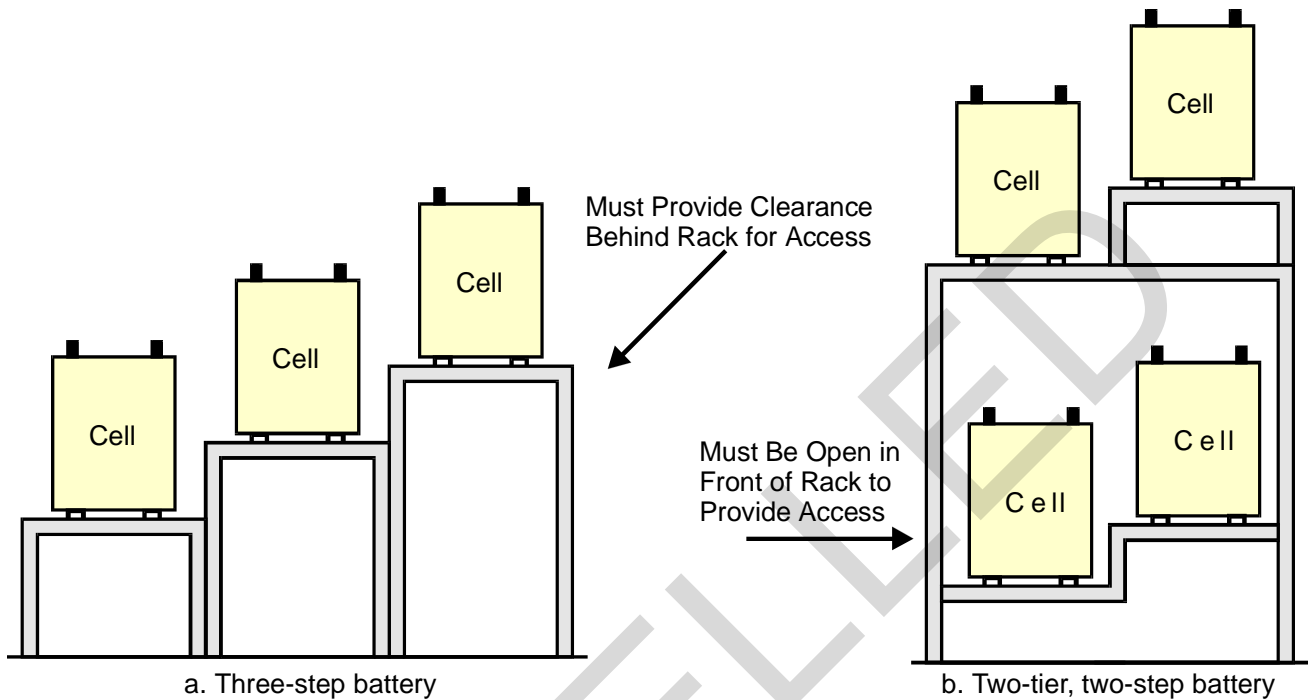

Figure 2-2. Larger Battery Rack Configurations (End View)



2-2.7.2 All racks for vented cell installations shall provide restraints to prevent the individual cells from overturning. In addition, battery racks shall comply with the latest edition of ASCE/SEI 7-05. Table 2-1 shows the rack requirements based on seismic design category.

Table 2-1. Battery Rack Requirements by Seismic Design Category

Seismic Design Category	Description
A—earthquakes are unlikely.	Racks do not require cell restraints.
B—distant earthquakes might cause minor motion.	Racks require side restraints.
C, D, E, F—local or nearby earthquake.	Racks require heavy-duty construction with side restraints and should have additional floor anchor points.

2-2.8 Batteries with a nominal voltage above 250 volts require special installation considerations as detailed in NFPA 70 Article 480.7 (2008 Edition).

2-2.9 Provide an overhead hoist or equivalent portable material handling equipment for the handling of batteries.

2-3 MECHANICAL REQUIREMENTS.

2-3.1 Design mechanical systems to maintain ventilation rates in accordance with NFPA 70E. Areas designated as a battery room shall be mechanically ventilated. Areas designated as battery enclosures shall be ventilated as required by the system manufacturer to meet the applicable codes.

2-3.2 Installation, operating, and maintenance requirements vary for each battery type. Refer to UFC 3-520-01 for battery selection guidance.

Note: Gelled electrolyte (Gel-cell) batteries and absorbed electrolyte batteries are both types of valve-regulated lead acid (VRLA) batteries, and have been inappropriately referred to as sealed maintenance-free batteries. Although the cell modules are sealed, making it incapable of water addition to the cells, each cell is equipped with a vent, which opens periodically to release internal pressure. The vent is typically open only for a fraction of a second, permitting small amounts of gas to escape. NFPA 70E and IEEE 1187 specify that VRLA cells be treated with the same hydrogen control measures as vented lead acid cells.

2-3.3 Comply with the following IEEE documents for temperature control criteria, as appropriate for the selected battery type:

- IEEE Std 484-2002, *IEEE Recommended Practice for Installation Design and Installation of Vented Lead acid Batteries for Stationary Applications.*
- IEEE Std 1106-2005, *IEEE Recommended Practice for Installation, Maintenance, Testing, and Replacement of Vented Nickel-Cadmium Batteries for Stationary Applications.*
- IEEE Std 1187-2002, *IEEE Recommended Practice for Installation Design and Installation of Valve-Regulated Lead acid Storage Batteries for Stationary Applications.*

Evaluate temperature conditions, and provide heating and ventilation as necessary to maintain temperature within the range 60° F (17° C) and 90° F (32° C). Base requirements on weather data obtained from UFC 3-400-02, *Design: Engineering Weather Data*. Air conditioning is not authorized. However, extended periods of high temperatures can reduce battery life; in those climates where dry-bulb temperatures are greater than 93° F (34 ° C) for more than 1,000 hours per year, air conditioning can be justified based upon life cycle costs. Compare initial, operating, and maintenance costs of providing air conditioning to the reduction in battery replacement costs. Perform the life cycle cost analysis IAW 10 CFR 436 and use Annex C from IEEE Std 1187 to determine expected battery life.

2-3.4 Design ventilation systems to maintain concentrations of hydrogen gas in the battery room below 1 percent concentration. Design the makeup (replacement) air volumetric flow rate equal to approximately 95 percent of the exhaust flow rate to

maintain the battery room under negative pressure and prevent the migration of fumes and gases into adjacent areas. Provide means for balancing air flow to ensure a negative pressure relationship. Exhaust all air directly to the outdoors. Exhaust air through a dedicated exhaust duct system if the battery room is not located on an outside wall. Makeup air can be transferred from a Class 1 or Class 2 area in the facility as defined in ASHRAE 62.1 or supplied directly. If supplied directly, it shall be filtered. Refer to Appendix B for an example of a volumetric flow rate calculation.

2-3.5 Fans shall be roof-mounted with an upwardly directed discharge. Fans will have non-sparking wheel and motor location outside of the air stream.

2-3.6 The air inlets shall be no higher than the tops of the battery cells of the lower tier if more than one tier is present. Locate exhaust grills at highest point of room. Ductwork shall be fabricated from fiberglass reinforced plastic (FRP) or polyvinyl chloride (PVC).

2-3.7 Design mechanical systems for continuous operation, free from excessive vibration. Provide green indicator light confirming fan operation located in battery area. Isolate mechanical equipment to eliminate structure-borne vibration which will have an adverse effect on battery usage and performance.

2-4 **ELECTRICAL REQUIREMENTS.**

2-4.1 Bond conductive battery racks, enclosures, and cable racks to ground using #6 AWG minimum conductors.

2-4.2 Provide overcurrent protection for each battery string. Paralleled battery strings shall provide separate overcurrent protection for each individual string. Provide a disconnect device at the point where the DC conductors leave the battery room, outside the room near the entrance.

2-4.3 Type AC, NM, NMC, NMS, and UF cable shall not be used in battery rooms. No flexible metal conduit or flexible metallic tubing shall be used. Connections to battery terminal posts, including intercell connections, shall minimize strain on the battery posts.

2-4.4 Provide temperature compensated charging for VRLA batteries based on the battery temperature, not the ambient temperature. Include temperature compensated charging for other battery installations where the area is not environmentally controlled and large temperature variations can occur.

2-4.5 Illuminance levels in the battery room shall be designed to meet IESNA Lighting Handbook recommendations with a minimum illumination level of 300 lux (30 fc). The lighting design shall consider the type of battery rack and the physical battery configuration to ensure that all points of connection, and maintenance and testing are adequately illuminated.

Battery room lighting fixtures shall be pendant or wall mounted and shall not provide a collection point for explosive gases. Fixtures shall offer lamp protection by shatterproof lenses or wire guards. Fixtures in battery rooms for vented cells shall be constructed to resist the corrosive effects of acid vapors. Luminaires and lamps shall provide minimal heat output in general and shall provide minimal radiant heating of the batteries. Lighting track shall not be installed in battery rooms. Fixture mounting shall not interfere with operation of lifting devices used for battery maintenance. Receptacles and lighting switches should be located outside of the battery area.

2-4.6 Provide instrumentation to measure battery voltage with high and low alarms, battery current, and ground detection for ungrounded systems. Provide the alarm system operation, level of reporting, and any additional instrumentation and alarm options appropriate for the specific conditions of each battery system.

2-4.7 Provide convenience receptacles as required for maintenance of the batteries, charging equipment, and distribution system.

2-5 **EMERGENCY FACILITIES.**

Provide portable or stationary water facilities for rinsing eyes and skin in case of electrolyte spillage. Locate within 20 feet of the battery. The station shall meet the requirements of ISEA Z 358.1. Provide a floor drain in the area of the station if a stationary water facility is provided.

2-6 **FIRE PROTECTION REQUIREMENTS.**

2-6.1 Comply with the requirements of UFC 3-600-01.

2-6.2 Provide fire protection for the battery system as required by NFPA 1. Smoke detection is not required.

2-6.3 Provide portable fire extinguishers within and adjacent to the battery room. The number, size, and location of portable fire extinguishers shall be appropriate for the battery system and shall be in accordance with NFPA 10, *Standard for Portable Fire Extinguishers*.

GLOSSARY

Abbreviations and Acronyms:

A—Ampere

AC—designation for NFPA 70 Armored Cable

Ah—Ampere-hour

AFPAM—Air Force Pamphlet

ANSI—American National Standards Institute

ASCE—American Society of Civil Engineers

AWG—American wire gauge

CFM—Cubic Feet per Minute

CFR—Code of Federal Regulations

DC—Direct Current

DoD—Department of Defense

fc—Footcandle

FRP—Fiberglass Reinforced Plastic

HR—Hydrogen Rate

IEEE—Institute of Electrical and Electronics Engineers

IESNA—Illuminating Engineering Society of North America

in—inches

mm—millimeters

NEC—National Electrical Code

NFPA—National Fire Protection Association

NM, NMC, and NMS—designations for NFPA 70 Nonmetallic Sheathed Cable

O&M—Operations & Maintenance

PVC—Polyvinyl Chloride

UF—designation for NFPA 70 Underground Feeder and Branch-Circuit Cable

UFC—Unified Facility Criteria

VR—Ventilation Rate

VRLA—Valve-Regulated Lead Acid

Terms:

Enclosure — A surrounding case or housing to protect the contained equipment against external conditions and to prevent personnel from accidentally contacting live parts. With respect to enclosures for stationary batteries, the enclosure might be a dedicated battery cabinet or it might contain additional equipment, such as an uninterruptible power supply.

Float Charge — The method of maintaining a battery in a charged condition by continuous, long-term charging at a level to balance self-discharge.

Full Float Operation — Operation of a dc system with the battery, battery charger, and load all connected in parallel, and with the battery charger supplying the normal dc load plus any self-discharge or charging current, or both, required by the battery. The battery will deliver current only when the load exceeds the charger output.

Primary Battery — A battery that produces electric current by electrochemical reactions without regard to the reversibility of those reactions. In the context of this UFC, a primary battery is not rechargeable, and is intended to be used once, then discarded.

Room — A contained area within a facility, normally accessible through a door. With respect to stationary batteries, a room might be dedicated for the battery installation or it might contain additional equipment.

Secondary Battery — A battery that is capable of repeated use through chemical reactions that are reversible, i.e., the discharged energy can be restored by supplying electrical current to recharge the cell.

Stationary Battery — A storage battery designed for service in a permanent location.

Storage Battery — A battery consisting of one or more cells electrically connected for producing electric energy.

Valve-Regulated Lead Acid (VRLA) Cell — A cell that is sealed with the exception of a valve that opens to the atmosphere when the internal gas pressure exceeds atmospheric pressure by a pre-selected amount. VRLA cells provide a means for recombination of internally generated oxygen and the suppression of hydrogen gas evolution to limit water consumption.

Vented Battery — A battery in which the products of electrolysis and evaporation are allowed to escape freely to the atmosphere. These batteries are commonly referred to as “flooded.”

APPENDIX A REFERENCES

GOVERNMENT PUBLICATIONS:

Department of Defense
<http://www.wbdg.org/ccb/>
<http://assist.daps.dla.mil/>

AFPAM 32-1186, Valve-Regulated Lead
Acid Batteries for Stationary Applications

EM 385-1-1, Safety and Health
Requirements

MIL-HDBK 411B, Power and the
Environment for Sensitive DoD
Electronic Equipment

UFC 3-400-02, Design: Engineering
Weather Data

UFC 3-410-04N, Design: Industrial
Ventilation

UFC 3-520-01, Design: Interior Electrical
Systems

UFC 3-560-01, Electrical Safety, O&M

UFC 3-600-01, Design: Fire Protection
Engineering for Facilities

UFC 4-229-01N, Design: General
Maintenance Facilities

U.S. Government Printing Office
Superintendent of Documents
U.S. Government Printing Office
Washington, DC 20402
<http://bookstore.gpo.gov/>

Title 29 Code of Federal Regulations,
Labor – Occupational Safety and Health
Administration (OSHA), Department of
Labor – Parts 1910 and 1926

Title 40 Code of Federal Regulations
Protection of Environment

NON-GOVERNMENT PUBLICATIONS:

American Society of Civil Engineers
1801 Alexander Bell Drive
Reston, Virginia 20191-4400
(800) 548-2723
www.asce.org

ASCE/SEI 7-05, Minimum Design Loads
for Buildings and Other Structures

ASHRAE
American Society of Heating,
Refrigerating and Air-Conditioning
Engineers, Inc.
720 Tully Circle
Atlanta, GA 30335
(800) 527-4723
<http://www.ashrae.org/>

ANSI/ASHRAE Standard 62.1,
Ventilation for Acceptable Indoor Quality

Illuminating Engineering Society of North
America (IESNA)
120 Wall Street, Floor 17
New York, NY 10005
212-248-5000
www.iesna.org

IESNA Lighting Handbook

IEEE
Institute of Electrical and Electronic
Engineers
3rd Park Avenue
New York, NY 10001
(212) 419-7900
<http://www.ieee.org>

IEEE Std 484-2002, IEEE
Recommended Practice for Installation
Design and Installation of Vented Lead
acid Batteries for Stationary Applications

IEEE Std 1106-2005, IEEE
Recommended Practice for Installation,
Maintenance, Testing, and Replacement
of Vented Nickel-Cadmium Batteries for
Stationary Applications

IEEE Std 1187-2002, IEEE
Recommended Practice for Installation
Design and Installation of Valve-
Regulated Lead acid Storage Batteries
for Stationary Applications

ISEA
International Safety Equipment
Association
1901 North Moore Street
Arlington, VA 22209-1762
(703) 525-1695
www.safetysafetyequipment.org

ISEA Z 358.1-2004, Emergency
Eyewash and Shower Equipment
(formerly ANSI Z 358.1)

NFPA
National Fire Protection Association
One Batterymarch Park, P.O. Box 9101
Quincy, MA 02269
(617) 770-3000
<http://www.nfpa.org>

NFPA 1, Uniform Fire Code
NFPA 10, Standard for Portable Fire
Extinguishers
NFPA 70, National Electrical Code
NFPA 70E, Electrical Safety in the
Workplace

CANCELLED

APPENDIX B SAMPLE VOLUMETRIC FLOW RATE CALCULATION

Appendix B provides a sample calculation of the required volumetric flow rate for the maximum expected hydrogen generation rate.

Design ventilation systems to maintain concentrations of hydrogen gas in the battery room below 1 percent concentration. Design the makeup (replacement) air volumetric flow rate equal to approximately 95 percent of the exhaust flow rate to maintain the battery room under negative pressure and prevent the migration of fumes and gases into adjacent areas.

One of the most effective methods of ventilation to control the concentration of hazardous gases is commonly referred to as dilution ventilation, or dilution of contaminated air. This is accomplished by exhausting the contaminated air from the battery room and replacing it with clean air from outside the room. Exhaust fans should be able to remove the air quickly.

The size of the fan, rated in cfm, is determined by the number of cells, maximum charge rate, cubic feet of hydrogen released per hour per cell per amp during charging, and the desired hydrogen gas buildup limit. The following formula is used to determine fan size:

$$\text{Hydrogen rate (HR)} = \text{emission rate} \times \text{charging current per 100 Ah} \times \\ \text{doubling factor} \times \frac{\text{cell capacity per 8 hour}}{\text{increment of cell}} \times \text{number of cells} \\ \text{capacity passing} \\ \text{charging current}$$

For example:

$$\text{Hydrogen rate (HR)} = 0.000269 \times 0.24/100 \times 2 \times 1360 \times 182 = 0.319$$

where:

0.000269	=	hydrogen emission rate per cell per ampere charge (cubic feet per minute)
0.24	=	charging current per 100-Ah cell capacity at 77 °F (ampere)
2	=	doubling factor for 15 °F (8 °C) rise in electrolyte temperature (above the normal 77 °F (25 °C))
1360	=	example capacity of one cell at the eight-hour rate (ampere-hour)
100	=	increment of cell capacity that will pass 0.24-A current charge (ampere hour)
182	=	number of cells

To meet the NFPA 70E ventilation requirements, limit hydrogen concentration to 1 percent. The required ventilation rate is:

$$\text{Ventilation rate (VR)} = \text{HR}/0.01$$

Ventilation rate (VR) = $0.317/0.01 = 31.7$ cfm

CANCELLED

APPENDIX C STATIONARY BATTERY APPLICABILITY

Appendix C provides examples of the types of stationary batteries that are addressed by this UFC. Examples of batteries not addressed by this UFC are also provided. The examples are typically provided in terms of the end-use application.

Applicable Battery Types/Locations

- Power plant backup power applications.
- Substations and switching stations – switchgear power.
- UPS batteries.
- Engine generator batteries, if installed inside enclosed areas.
- Centralized emergency lighting.
- Communication center batteries.
- Stationary batteries maintained on float charge before shipboard installation.

Excluded Battery Types/Locations

- Small batteries used for portable equipment.
- Vehicle batteries.
- Batteries in storage and not on float charge.
- Small emergency lights with an internal battery.
- Shipboard and airplane batteries.
- Battery maintenance and repair facilities – excluded from this UFC only because these facilities are specifically addressed by UFC 4-229-01N, *Design: General Maintenance Facilities*, and UFC 3-410-04N, *Design: Industrial Ventilation*. These facilities typically handle large quantities of electrolyte, which leads to unique designs for ventilation control.