

UNIFIED FACILITIES CRITERIA (UFC)

HAZARDOUS WASTE LAND DISPOSAL/LAND TREATMENT FACILITIES



APPROVED FOR PUBLIC RELEASE; DISTRIBUTION UNLIMITED

**HAZARDOUS WASTE LAND DISPOSAL/LAND
TREATMENT FACILITIES**

HEADQUARTERS DEPARTMENT OF THE ARMY

NOVEMBER 1984

REPRODUCTION AUTHORIZATION/RESTRICTIONS

This manual has been prepared by or for the Government and is public property and not subject to copyright.

Reprints or reproductions of this manual should include a credit substantially as follows: "Department of the Army Technical Manual TM 5-814-7, Hazardous Waste Land Disposal/Land Treatment Facilities, date."

CANCELLED

**HAZARDOUS WASTE LAND DISPOSAL/
 LAND TREATMENT FACILITIES**

	Paragraph	Page
Chapter 1. INTRODUCTION		
Purpose	1-1	1-1
Scope	1-2	1-1
2. REGULATORY FRAMEWORK		
Federal regulations	2-1	2-1
State and local regulatory requirements	2-2	2-1
Army regulations	2-3	2-2
3. PRE-DESIGN EVALUATION OF SITE CONDITIONS		
Environmental and sociopolitical conditions	3-1	3-1
Review of relevant site data	3-2	3-1
Hydrogeologic conditions	3-3	3-2
Climate elements	3-4	3-4
Impact of site conditions on selection of disposal method	3-5	3-4
Design requirements imposed by hydrogeologic conditions	3-6	3-5
4. DISPOSAL AND HANDLING CONSTRAINTS IMPOSED BY WASTE COMPOSITION		
Impact of waste stream on selection of disposal type	4-1	4-1
Design and handling constraints imposed by waste composition	4-2	4-1
Waste analysis plan	4-3	4-1
5. LAND DISPOSAL/LAND TREATMENT OPTIONS		
Introduction	5-1	5-1
Landfills	5-2	5-3
Surface impoundments	5-3	5-4
Land treatment	5-4	5-7
Deep well injection	5-5	5-12
Waste piles	5-6	5-13
6. HAZARDOUS WASTE FACILITY DESIGN ELEMENTS		
Introduction	6-1	6-1
Flood control systems	6-2	6-1
Liner systems	6-3	6-1
Leak detection and leachate collection and removal systems	6-4	6-11
Surface water run-on and run-off control systems	6-5	6-14
Gas control systems	6-6	6-21
Final cover	6-7	6-22
Special design elements	6-8	6-25
7. OPERATIONS AND CONTINGENCY PLANS/TRAINING		
Operations	7-1	7-1
Permit application assistance	7-2	7-2
Contingency plans	7-3	7-2
Personnel requirements, training, and safety	7-4	7-2
8. GROUND-WATER MONITORING		
Introduction	8-1	8-1
Monitoring requirements	8-2	8-1
Monitoring program	8-3	8-1
9. CLOSURE AND POST-CLOSURE PLANS		
Introduction	9-1	9-1
Closure procedures	9-2	9-1
Components of closure plan	9-3	9-1
Post-closure plans	9-4	9-2
10. COST ANALYSIS		
Cost elements	10-1	10-1
Unit costs	10-2	10-1
Appendix A REFERENCES		A-1
B FEDERAL AND STATE HAZARDOUS WASTE REGULATIONS.....		B-1
C EXAMPLE DESIGN PROBLEM.....		C-1
BIBLIOGRAPHY		BIBLIO-1

LIST OF FIGURES

		Page
Figure	5-1 Illustrative hazardous waste master plan	5-2
	5-2 Landfill operations plan	5-5
	5-3 Land treatment area details	5-9
	5-4 Land treatment operations plan	5-11
	5-5 Deep injection well	5-14
	6-1 Flood control structures	6-2
	6-2 Base liner details for landfills and surface impoundments	6-5
	6-3 Base liner details for waste piles	6-6
	6-4 Typical clay liner compatibility evaluation	6-10
	6-5 Typical leak detection systems and leachate collection drains	6-13
	6-6 Typical run on control ditches	6-16
	6-7 Typical run-on control ditch for waste units	6-17
	6-8 Typical run-off control ditch for final cover areas	6-18
	6-9 Run-on sedimentation control run-off retention basins	6-20
	6-10 Final cover details	6-23
	8-1 Monitoring well details	8-3
	8-2 Monitoring well installations	8-4

LIST OF TABLES

Table	3-1 Composition and quantity data resources	3-2
	3-2 Design/operational requirements imposed by hydrogeologic conditions	3-6
	5-1 Design features required by RCRA for DA land disposal and treatment facilities	5-1
	6-1 Requirements for liner systems	6-3
	6-2 Summary of liner types	6-7
	6-3 Seaming provisions for synthetic liners	6-11
	6-4 Requirements for leachate collection and removal systems	6-12
	6-5 Requirements for surface water run on and run-off control systems	6-15
	6-6 Requirements for final cover at closure	6-22
	6-7 Requirements for special design elements	6-26
	10-1 Summary of unit costs for lined facility	10-1

CHAPTER 1

INTRODUCTION

1-1. Purpose

The purpose of TM 5-814-7 is to establish Army design criteria that comply with the national goal of ground-water protection. On the Federal level, subtitle C of the Resource Conservation and Recovery Act (RCRA) of 1976 (42 United States Code [USC] 6901 et. seq.) promulgated standards for the management of hazardous wastes. Of particular interest to the design engineer in subtitle C of (RCRA) are design standards for land disposal/land treatment facilities presented in 40 Code of Federal Regulations (CFR) 264. This section of the law presents two sets of performance standards applicable to this technical manual-one for land disposal/land treatment facilities and the other for ground-water monitoring. The performance standards are directed toward (1) minimization of leachate generation in the waste management facilities and removal of leachate produced before it can enter the subsurface environment (subparts K through N), and (2) backup ground-water monitoring and response programs to remove any detected leachate from the ground water (subpart F).

1-2. Scope

The regulatory framework for these design standards is described in chapter 2 of the manual; as noted throughout this manual, where Army criteria are more stringent than other regulatory standards, the Army criteria are preeminent. Chapter 3 addresses pre-design evaluation of site conditions, the important first step the design engineer must take prior to developing design criteria for a facility. Another essential pre-design consideration, disposal and handling constraints imposed by waste composition, is addressed in chapter 4. The heart of the design manual lies in chapters 5 and 6. Chapter 5 describes landfills, impoundments, land treatment, deep well injections and waste piles with respect to waste suitability, disposal constraints, procedures and equipment; chapter 6 presents the specific engineering design elements for the five disposal options. Summarized in chapters 7 through 9 are plans and monitoring requirements for hazardous waste land disposal/land treatment facilities generally dictated by 40 CFR 264. Cost elements for lined hazardous waste facilities are described in chapter 10.

CHAPTER 2

REGULATORY FRAMEWORK

2-1. Federal regulations

a. The Resource Conservation and Recovery Act (42 USC 6901 et. seq.) or, as it is more commonly referred to, (RCRA), requires all operators of hazardous waste management facilities to apply to the US Environmental Protection Agency (EPA) or an authorized state agency for a permit to operate the facility. In addition to providing compliance requirements for the private sector, (RCRA) mandates compliance for each department, agency and instrumentality of the executive, legislative and judicial branches of the Federal Government (42 USC 6961, subtitle F). Subtitle F states that the compliance is to be "... both substantive and procedural (including any requirements for permits or reporting or any injunctive relief and such sanctions as may be imposed by a court to enforce such relief).

Neither the United States nor any agency, employee or officer thereof shall be immune or exempt from any process or sanction or any State or Federal Court with respect to the enforcement of any such injunctive relief."

b. The applicability of (RCRA) as the primary instrument regulating the treatment, storage, transportation and disposal of hazardous wastes is underscored by 42 USC 6905, subtitle A. This part of the law instructs EPA to avoid administrative and enforcement duplication by integrating the program of (RCRA) regulations to the maximum extent possible with applicable provisions of the--

- Clean Water Act
- Safe Drinking Water Act
- Clean Air Act
- Federal Insecticide, Fungicide and Rodenticide Act
- Marine Protection Research and Sanctuaries Act

c. The principal source of design criteria for land treatment/disposal facilities, is title 40, (CFR) part 264.

Other sections of the law and regulatory program, such as the definitions in part 260 and the hazardous waste criteria in part 261, may also influence the design of facilities in a less direct manner. Presented in appendix B are the parts of 40 (CFR) and the elements of those parts pertinent to this technical manual.

d. The (RCRA) part 264 regulations consist primarily of two sets of performance standards-one for land disposal/land treatment units and the other for ground-water monitoring. The first set of standards, contained in subparts K through N of the regulations, enumerates design and operating standards separately tailored to surface impoundments, waste piles, land

treatment and landfills, respectively. The second set of standards contained in subpart F, establishes criteria for a ground-water monitoring and response program applicable to land disposal/land treatment facilities.

2-2. State and local regulatory requirements.

a. state cannot assume the responsibility for regulating hazardous wastes until the administrator of EPA determines that the state program is equivalent to the Federal requirements. Thus, the EPA standards are minimum requirements; nothing prevents states from establishing additional or more stringent regulations. In a number of states this is precisely the situation. For example, the majority of states have laws which actively discourage the use of land disposal for hazardous wastes or ban burial of these materials; New York has denied land disposal permits on the grounds that applicants failed to provide adequately for alternative technologies to landfilling (US Congress, Office of Technology Assessment IOTA], 1983). In other states the laws may require additional permits for hazardous waste facilities besides those required by (RCRA), or they may have commissions authorized to impose more stringent land use controls than the state regulatory program. It is therefore, necessary for the facility designer to review the requirements of the state where the facility is or will be located.

b. In addition, it is important to determine whether or not the state is fully authorized to control its hazardous waste management program. As of February 1983, 16 states were operating under cooperative arrangements or partial authorizations; 34 states and 1 territory had interim authorization, while 9 states had partially satisfied the Phase II requirements leading to complete authorization of their program.

c. The differences between states will usually be related to the types and quantities of controlled wastes, exemptions, geotechnical requirements, and the use of more specific design criteria to implement part 264 performance standards. Early review of applicable state requirements, and a comparison of their technical and regulatory elements with the EPA program can disclose any variations which may affect design work. Appendix B further defines the individual state programs by comparing the "universe of regulated wastes" with the (RCRA) waste listing and identifying land disposal restrictions and siting procedures for each state.

d. Local controls will be secondary to state and federal requirements with respect to Army installations;

they will principally relate to zoning, roads and air quality.

2-3. Army regulations

a. The Department of the Army's (DA) program for compliance with environmental protection standards of Federal, State, interstate and local agencies is established by Army Regulations (AR) 200-1 and 200-2. AR 200-1, paragraph 1-1, "prescribes (DA) policy, responsibilities, and procedures to protect and preserve the quality of the environment." AR 200-2, paragraph 1-1, states (DA) policy and "establishes procedures for the integration of environmental considerations into Army planning and decision-making in accordance with 42 USC 4321 et. seq., the 'National Environmental Policy Act of 1969' (NEPA)."

b. Management programs for both hazardous materials and hazardous wastes are described in chapters 5 and 6 of AR 200-1. Procedures to implement the management programs are tied to the requirements of the primary hazardous waste/hazardous material regulations: NEPA, RCRA, The Clean Water Act, The Marine Protection Research and Sanctuaries Act of 1932, and the Toxic Substances Control Act of 1976. AR 200-1, paragraph 6-3, increases the range of regulatory compliance by emphasizing DA's policy on source

reduction, recovery and recycling.

c. AR 200-2 describes procedures that the Army will employ to comply with the requirements set out by NEPA. Specifically, paragraph 3-1 of the regulation requires the DA to integrate NEPA's "systematic examination of the possible and probable environmental consequences of implementing a proposed action," and development of a written report Environmental Impact Statement (EIS). Certain categories of actions are exempt from the above requirement; AR 200-2, paragraph 3-3, defines the categories and associated requirements (or exemptions). However, even if an EIS is not required, an Environmental Assessment (EA) may be needed (AR 200-2, para 5-1). Actions typically requiring an EA include changes to established installation land use which may be expected to have some impact on the environment, and generation of hazardous or toxic materials (AR 200-2, para 5-3).

d. AR 200-2, paragraph 3-5, states that these environmental assessment documents "should be forwarded to the planners, designers, and/or implementers so that recommendations and mitigations.. . may be carried out." Prior to the start up of any construction work, the designer (through the installation) must ensure that required EA's and EIS's have been completed and project go-ahead has been finalized.

CHAPTER 3

PRE-DESIGN EVALUATION OF SITE CONDITIONS

3-1. Environmental and sociopolitical conditions

a. An owner or operator of any facility that treats, stores, or disposes of hazardous waste must be aware of and respond to the concerns of the public in the surrounding communities. In many cases defense installations are physically isolated and treated as separate entities in matters of operations management, land use, and economics. Personnel employed on the base must respond to Army security regulations, thereby defining recreational, public service and housing issues.

b. Health and safety risks are minimized by allowing only authorized personnel into and around restricted hazardous waste treatment, storage or disposal areas. Actual security measures for a facility are given in AR 200-1 and 40 CFR 264 in addition to specific state requirements.

c. If a new Army installation were constructed, an Environmental Impact Statement (EIS) would be required in accordance with AR 200-2; in many cases, projects at existing facilities would also require an EIS or, at minimum, an environmental assessment. The EIS would address the sociopolitical and environmental concerns associated with the planned hazardous waste treatment/disposal facilities. Other activities at the installation may require the approval of local air basin authorities and water quality control boards.

d. Transportation of hazardous waste materials off site requires compliance with state and federal transportation regulations. The potential health risks associated with transport of chemicals on public roads implies that the public and health officials will be concerned and involved.

3-2. Review of relevant site data

a. Prior to the initiation of any design work involving hazardous waste treatment, storage or disposal, the design engineer must become familiar with available records concerning overall site conditions, and those concerning waste types and quantities associated with the particular unit. If an existing unit is being modified to treat an existing waste stream, documentation on the design and engineering aspects of the facility, as well as documentation on the composition and quantity of the waste stream should be available from on-post sources. However, if a new disposal/treatment facility is being designed and constructed to handle new waste streams from either on or off post, a more exhaustive data search will be required.

(1) Data sources available to the design engineer include RCRA-related documents, installation manuals and records, and agency maps, drawings and guidance manuals. Source documents for each facility will vary depending upon the unit to be constructed or modified, the anticipated waste stream, and the record keeping system at the installation. Examples of these data sources include

- (a) RCRA-Related Documents:
 - Part A Permit Application
 - Part B Permit Application
 - Hazardous Waste Annual Reports
 - Operating Records
 - Hazardous Waste Manifests
 - Interim Status Documents
 - Regulations (regarding design and operating parameters)
- (b) Installation Documents:
 - Design, Construction and Operating Provisions
 - Site Plans; Topographic Maps
 - Waste Discharge Requirements
 - Environmental Impact Statements
 - Installation Assessments
 - Spill Prevention Control and Countermeasure Plan
 - USATHAMA Records Search Reports
 - Standard Operating Procedures
 - Department of Defense Form 1348-1 (Item Release/Receipt Document)
 - DA Form 4508 (Ammunition Transfer Record)
 - Waste Inventories
 - Site Photographs
 - Subsurface and Foundation Investigation Reports
 - Installation Master Plan Drawings
- (c) State or Federal Agency Documents:
 - National Pollutant Discharge Elimination System (NPDES) Permits
 - Installation Inspection Reports
 - US Geological Survey (USGS) Maps
 - Federal Emergency Management (FEMA) Flood Insurance Study
 - State Geologic and Hydrologic Maps and Reports
 - Design Guidance Manuals

(2) A number of these resource documents offer valuable information on the composition and quantities of wastes handled by a given facility. Table 3-1

Table 3-1. Composition and Quantity Data Resources

Specific Source	Authority	Information Available
RCRA Part A Permit Application process	40 CFR 270.1	Identifies, in a cursory manner, the types of wastes generated (coded according to 40 CFR 261 Subpart D), estimated annual generation quantities, the process and design capacities.
RCRA Part B Permit Application	40 CFR 270.14	Requires the submittal of all Interim Status Documents. Pertinent information includes: chemical and physical analysis of hazardous wastes to be handled at the facility, waste analysis plan, description of procedures, structures and equipment, procedures for handling ignitable, reactive, corrosive and incompatible wastes, closure plan, plus specific information pertaining to individual wastes treatment/disposal facilities, (e.g., waste piles, surface impoundments).
Hazardous Waste Annual Reports: (EPA forms 8700-13 and 8700-13A)	40 CFR 262.41 Subpart D	Gives a summation of all waste types and quantities generated during each year. Submitted to EPA and/or state officials.
Hazardous Waste Manifests concentration	40 CFR 264.70 Subpart E	Identifies waste transported to the site and off site; includes proper shipping names, hazard class (49 CFR Part 172), weight or volume, components and range. Copies of the manifest must be kept at the facility for at least three years.
Operating Records	40 CFR 264.73	Description and quantity of each hazardous waste received and the methods and dates of treatment, storage or disposal; records maintained until facility closure.
DD Form 1348-1: (DOD Single Line Release/Receipt Document)	AR200-1 Paragraph 5-6(d)	Identifies (DPDO) material or waste, its origination and destination, type and number of containers, material condition, and freight classification.
Spill Prevention Control and Countermeasure (SPCC) Plan	Section 311 of the Clean Water Act PL 95-217	Inventory of all sources of oil and hazardous substances
National Pollutant Discharge Elimination System (NPDES) Permit	AR 200-1 (paragraph 8-6) Section 402 of the Clean Water Act PL 95-217	Permit specifies the type and quantities of liquid wastes that may be discharged into the nation's water sources.

US Army Corps of Engineers

reviews the kind of information available in some of these documents.

(3) Interviews with facility or installation personnel in connection with site visits will aid in the collection and interpretation of the various sources of information on waste generation and site conditions. The Defense Property Disposal Office has chemical inventories of both waste materials and off-spec supplies (being stored for resale). Many installations have an Environmental Office which is responsible for securing permits, record keeping, and waste stream update information.

b. Information may also be obtained from off-site resources. The following is a partial list of sources:

- US EPA Office of Solid Waste
- US EPA Municipal Environmental Research Laboratory
- US Army Environmental Hygiene Agency
- US Army Toxic and Hazardous Materials Agency
- US Army Corp of Engineers' Research and Development Laboratories (WES, CERL and CRREL)
- Defense Logistics Agency

Public Libraries (EIR, EIS, local and state requirements)
State Health Department

3-3. Hydrogeologic conditions

a. Protection of ground-water resources is a primary concern in the design and operation of any facility involved with the handling of wastes. The potential for pollution can develop if wastes are placed in improper hydrogeologic settings where wastes and/or leachate products may easily enter the ground-water system.

(1) Ground-water protection has been one of EPA's central concerns in devising a regulatory strategy for hazardous waste land disposal. A large number of the documented damage cases for hazardous waste land disposal have involved ground-water contamination. Likewise the legislative history of RCRA, including the damage cases cited in the 1976 Senate Report, indicates that the Congress was quite concerned about ground-water contamination when it created the hazardous waste program. Accordingly, today's regulations deal very explicitly with ground-water protection.

(2) Ground-water protection can be ensured only

through a clear understanding of the hydrogeologic environment in which the wastes are to be placed. Hydrogeologic considerations to be addressed include:

- Review of published and unpublished data on ground-water availability and quality
- Ground-water flow quantity and direction under the site *
- Relationship of the site to ground-water basin recharge areas
- Ground-water use near the site, including review of available well logs and water well inventories (available from some state agencies)
- Identification of uppermost aquifers
- Location of regional aquifers and aquicludes and regional flow information

b. Protection of surface-water resources is another important concern in the design and operation of a hazardous waste land disposal/land treatment facility. A surface-water assessment of the site is recommended to determine (1) water quality of streams and other surface-water sources within the area, and (2) the ratio of baseflow discharge from upstream sources to any potential permitted discharges (to determine how much dilution occurs).

c. Information relating to regional and site hydrogeologic conditions on the following is also required:

- Geologic mapping of the site.
- Detailed boring logs and test pits of subsurface soils and geology characterizing the base of the uppermost aquifer.
- Detailed chemical analysis of all aquifers that are potential water supply sources or which have the potential for contamination.
- Surface elevations and drainage.
- Soil classification and geotechnical properties.
- Measurement of permeability of soils and formations between the base of the disposal unit and uppermost aquifer.

d. A comprehensive geotechnical testing program might include:

- Soil classification tests.
- Compaction tests.
- Unconfined compressive strength tests.
- Triaxial compression tests.
- Direct shear tests.
- Permeability testing.
- Background contaminant level tests (EM 11102-1906).

These tests are typically conducted in accordance with American Society for Testing and Materials (ASTM) methods.

e. Methods of approach for site investigations may be found in Design of Small Dams, US Department of Interior (1973), TM 5-818-1, NAVFAC DM 7.1 and EPA Manual SW-963.

f. Subsurface information obtained from boring

logs may also be supplemented by geophysical methods. Geophysical surveys give the designer the advantage of examining large areas at one time, facilitating the correlation of borehole data around the site and delineation of overall site geology. However, it is important to note that the usefulness of a given geophysical method is dependent on site-specific conditions and must be assessed on a case-by-case basis. Geophysical methods include:

(1) Electrical "E" Logs-This process involves measuring electrical properties of soils and geologic formations in uncased boreholes. The data collected will yield information on potential of strata to transmit water, occurrence of water and general water quality. Cost may vary depending on hole depth and condition.

(2) Electrical Resistivity Survey-This method employs vertical electrical soundings (VES) which transmit electrical currents into the ground. The VES may be considered an electrical "drill hole" which may define subsurface strata. This relatively inexpensive technique enables rapid evaluation of subsurface conditions to a depth of approximately 200 feet.

(3) Magnetometer Survey-This method measures magnetic intensity of rock and strata for defining geologic structure. Magnetometer surveys can cover large areas at minimum cost.

(4) Seismic Refraction Survey-Seismic refraction surveys use sonic waves created by small explosions (or sledge hammer or other vibro-mechanical means) to map variations in bedrock hardness. These surveys can provide information on competency of bedrock (indicative of rock rippability) and degree of weathering, as well as changes in these properties with depth. Seismic surveys are capable of scanning large areas for a moderate cost.

g. Additional information on regional seismicity is required in seismically active areas of the United States: 40 CFR 264.18 requires special seismic studies for new hazardous waste facilities in a number of western and midwestern states. Appendix VI to part 264 lists political jurisdiction for which this requirement is mandated. The design engineer is also advised to review seismic zone maps presented in TM 5-809-10 (para 3-4) for additional information. In seismically active areas, the services of a soils engineer familiar with seismic engineering may be needed to determine the effects of seismic loads to foundations and fills caused by ground acceleration and shaking. Static and dynamic analysis may be required to predict potential slope failure.

h. In summary, data evaluation is critical to individual facility siting and must consider maximum advantage of the site's hydrogeologic and geotechnical factors. Assessment of soil engineering properties will dictate types of design and availability of on-site mate

rial. All facilities must be designed for specialized problems such as seismic shaking in seismically active areas, or expansive soils.

3-4. Climatic elements

a. Climatic conditions, particularly precipitation, evaporation, temperature, and wind, can significantly influence the selection, design and operation of land disposal facilities. Adverse climatic conditions can, for example:

- (1) Prevent use or operation of
 - Surface Impoundments practicing evaporative disposal of wastes, if annual precipitation is greater than annual evaporation.
 - Land Treatment facilities, if soils in the treatment area are frozen or saturated.
- (2) Restrict operation of—
 - Surface Impoundments, where heavy rainfall reduces storage capacity.
 - Land Treatment facilities, where lower temperatures will decrease biodegradation rates.
 - Landfills, where (1) freezing soil or wastes interfere with proper placement or compaction of wastes, soil cover or earthfills, (2) accumulation of snow may require clearing, or (3) snow melt may increase the moisture content of the waste.
- (3) Impact closure practices at impoundments and landfills
 - Disruption of the compacted soil zone through frost heave (water migration and freezing in layers, lenses or veins of ice).
 - Sliding resulting from thawing of a shallow, saturated zone of soil cover.
 - Rainfall erosion of the soil cover.

b. Generalized climatic data are available from the National Climatic Center of the National Oceanic and Atmospheric Administration and the National Weather Service. Local meteorological data is often available at Army installations that have air fields. In addition, some states have official weather observation stations that offer climatic data. Selected publications which provide recorded data, frequency and duration analyses, and general charts for various climatic elements are listed in the references (appendix A).

c. Another source of information is the US Weather Bureau, whose 300 first-order weather stations provide data on:

- Daily and monthly temperature
- Dewpoint
- Precipitation
- Pressure
- Wind
- Sunshine and cloud cover
- Solar radiation

d. Weather stations also publish climatic tables of

normal, mean and extreme values for long periods of record and climatic maps of the United States. Design data directly available from the US Weather Bureau include isobars for 24-hour rainfalls and for average annual lake evaporation.

e. In addition, numerous theories, empirical correlations, modeling procedures and charts have been developed for defining and predicting the impact of climatic elements on design. Those useful in designing land disposal facilities include equations for infiltration and run off, rainfall and wind erosion, and wind waves; depth of freezing indices; and evaporation/evapotranspiration calculations. State and local agencies have used available climatic data to develop charts and tables which can be used in these predictive calculations—including the rainfall and storm recurrence tables and rainfall intensity/duration charts used for run-off calculations.

3-5. Impact of site conditions on selection of disposal method

a. Most regulations dealing with disposal to land clearly reflect the sensitive relationship between waste type, disposal method, and potential for natural or engineered protection of the environment at the proposed disposal facility. Sites that are designed to accept only solid, generally inert substances, obviously require fewer natural containment features than do those intended for liquid hazardous waste. Similarly, siting of waste piles or land treatment facilities may be far less restrictive than siting of impoundments.

b. Site conditions which obviously prohibit development of a disposal site of any type are wetlands and locations in critical aquifer recharge areas. Site conditions that impact selection of disposal methods fall into three basic areas (1) ability for ground-water protection, (2) potential for surface water contact with wastes, and (3) availability of materials required by each disposal method. Almost any negative site condition can be overcome by engineering designs; however, these engineering solutions can often result in unacceptable economic impacts and/or regulatory monitoring requirements.

(1) In selecting a disposal method, two key elements regarding ground-water protection must be considered: (1) vertical separation of wastes from the uppermost ground-water, and (2) permeability of the subsurface material providing the hydraulic separation. These two elements are interrelated. Far less separation between waste and ground-water can be tolerated in a low permeability clay environment than in a site underlain by sand and gravel. However, design considerations of the natural ground-water setting can be greatly influenced by regulations mandated by 40 CFR 264 requiring the placement of impermeable liners beneath landfills, impoundments and waste piles.

(a) Surface impoundments should be sited and designed with maximum protection of ground water provided by liners, low permeability clay (10-8 cm/sec) underlying soils, and maximum separation. The hydraulic head formed in the impoundment provides for a high potential for liquid seepage and subsurface migration.

(b) Since potential for buildup of hydraulic head in landfills and waste piles is much less than for impoundments, siting criteria can be somewhat relaxed for these facilities. With liners beneath the waste, soils with permeabilities in the vicinity of 10-6 cm/sec (silts, silty clays) may be acceptable separation materials.

(c) In land treatment facilities little or no hydraulic head buildup is created; however, strict operational criteria are required by RCRA to ensure their protection. Such facilities can be located in most locales that provide a minimum separation from groundwater of approximately 10 feet, and moderately low permeability soils (10-4 to 10-5 cm/sec-silty sands, silts).

(d) Limitations in locating injection wells are discussed in paragraph 5-5.

(2) Isolation of wastes from surface water is a major concern in the design and locating of all disposal methods. It is highly recommended that disposal units be located out of a 100-year flood plain and away from topographic areas prone to flash flooding and/or severe erosion; avoidance of flood plain areas may be mandatory for certain types of hazardous wastes. All disposal modes (landfills, impoundments, etc.) should be designed with drainage diversion and surface run on protection and isolation facilities (i.e., berms, dikes, etc.). High design and construction costs may be associated with sites located within flood areas and/or in areas requiring diversion of surface runoff from large upgradient watersheds. With proper facility design, surface water conditions should not be a major factor in selection of a disposal type, but only in selection of design criteria.

(3) Each disposal type has its own soil requirements for construction and operation. Although all materials can be imported from off-site sources, project costs can, as a result, become prohibitive. In sites located in areas underlain by shallow cemented bedrock, nearly all soil materials may need to be imported; as a result, costs for landfilling in such areas can be prohibitive. Sites underlain by clay deposits significantly reduce the cost of construction of all types of disposal facilities. Below is a summary of soil needs for different disposal methods:

<i>Disposal Type</i>	<i>Soil Needs</i>
Landfill	Daily and intermediate cover; a variety of soil types are acceptable. Final cover soils must be low permeability clays. Liner soil must be clay.
Surface Impoundments	Liner soil must be low permeability clay.
Waste Piles	Liner soil must be low permeability clay.
Land Treatment	Treatment zone must have minimum of 5 feet of suitable soil, as described in section 5-4 b (2).

3-6. Design requirements imposed by hydrogeologic conditions

Less than ideal hydrogeologic conditions can be overcome by engineering designs in all but the most extreme conditions. However, the site owner/operator must be aware that great expense may be involved in these engineering solutions, and may make the project economically unfeasible. Table 3-2 summarizes the major design/operational requirements imposed by unfavorable hydrogeologic conditions.

Table 3-2. Design/Operational Requirements Imposed by Hydrogeologic Conditions

Unfavorable Hydrogeologic Conditions	Requirements
<i>Ground Water</i> High ground-water table High permeability soils	Placement of impermeable liners; dewatering systems to lower ground water; increased monitoring.
<i>Surface Water</i> Within flood plain Inter-related to shallow ground water beneath facility Extensive upgradient watershed	Construction of perimeter dikes/levees; liners to interrupt connection between ground and surface waters; construction of drainage diversion facilities.
<i>Faults</i>	Location of facilities outside of a fault buffer zone.
<i>Soils</i> Inadequate soils for cover or impermeable barriers*	Importation of soils that meet regulatory requirements.
<i>Active Karst Zones</i> Sinkhole-prone areas Solution channels	Location of facilities outside of active Karst zones is recommended.

*As used here, inadequate means either (1) unable to meet regulatory requirements for soil type and permeability, or (2) insufficient quantities to meet design/operational needs.

US Army Corps of Engineers

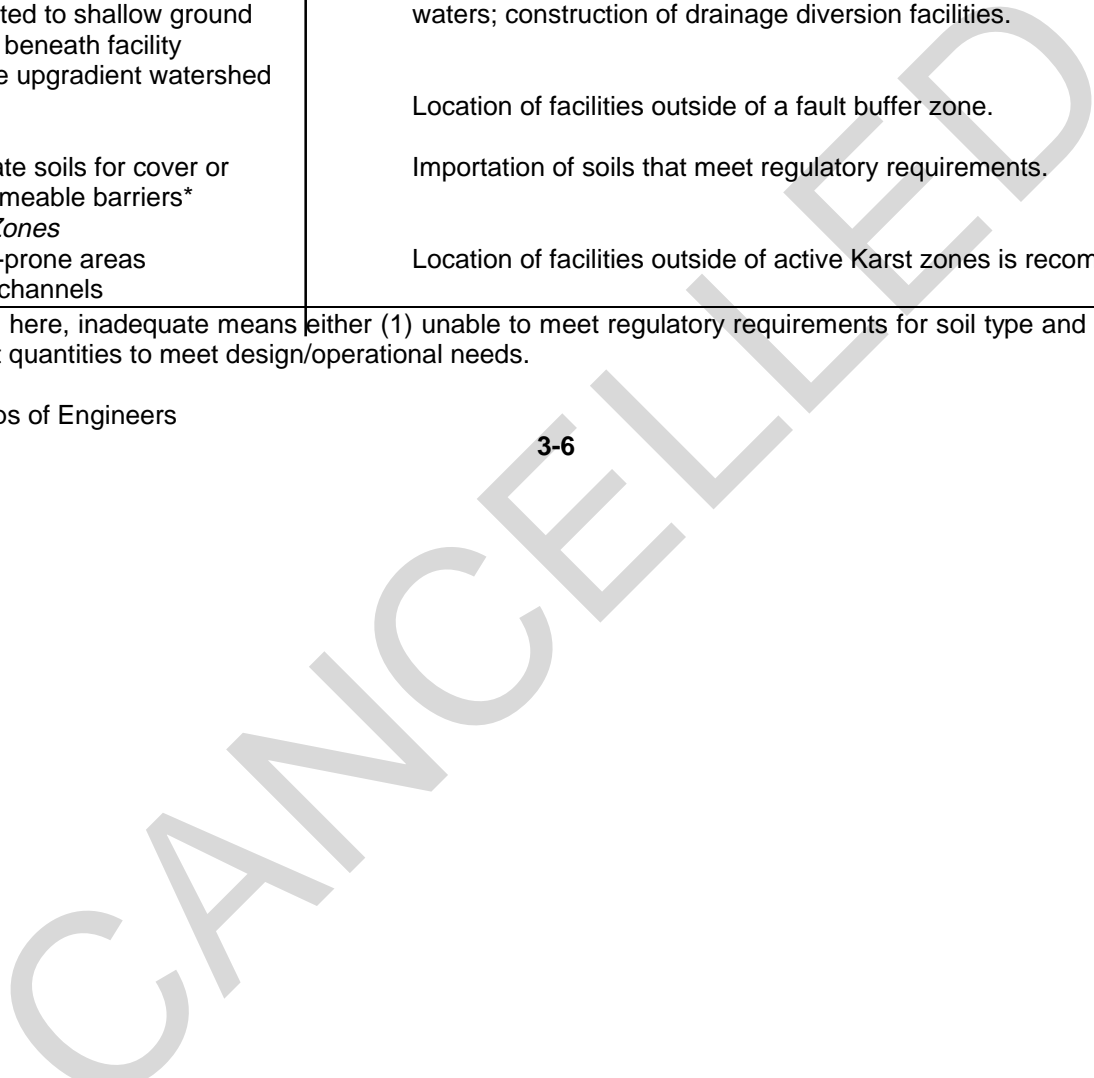

CHAPTER 4

DISPOSAL AND HANDLING
CONSTRAINTS IMPOSED BY WASTE COMPOSITION**4-1. Impact of the waste stream on selection of disposal type.**

a. The physical state of the hazardous waste and the chemical characteristics of the waste are the two most important factors to be evaluated in selecting the appropriate disposal option. With respect to physical state, disposal options at Army installations for bulk liquid hazardous wastes and sludges with leachable liquids are limited to surface impoundments and, in certain special cases, injection wells. The latter, rarely used because of the hydrogeologic constraints inherent in their siting, are suitable for large quantities of aqueous wastes, including acids, alkalis, inorganic brines and oily waste waters (see chapter 5).

b. Most solid hazardous wastes are disposed of in landfills; however, small quantities of semi-solid and solid hazardous wastes such as mine tailings are stored or treated in waste piles. It is important to note that RCRA regulations stipulate that waste piles may not be used as an ultimate disposal method; if the owner/operator of a waste pile wants to dispose of the accumulated wastes, he must obtain a landfill permit and manage the pile as a landfill.

c. The second major factor concerning the waste stream that impacts selection of disposal type is the chemical/physical characteristics of the waste. Restrictions based on these characteristics are that ignitable or reactive wastes may not be placed in a facility unless the waste is rendered non-ignitable or non-reactive and incompatible wastes may not be placed in the same facility.

4-2. Design and handling constraints imposed by waste composition

a. The physical and chemical characteristics of a particular waste impose the primary constraints in managing these wastes. Characteristics which must be considered include ignitability, reactivity, corrosivity, compatibility and physical state (liquid or a solid). Other composition factors which must be evaluated are the chemical makeup of the waste, its mobility in soil (and water), metal concentrations and, indirectly, the containerization method.

b. Ignitability and reactivity are defined in 40 CFR 261. These definitions, in combination with the federal requirements given in the Hazardous Waste Permit Program outline the requirements and waste composition constraints for individual hazardous waste facilities; surface impoundments, waste piles, land treat

ment and landfills. In general, ignitable or reactive waste must not be placed in a hazardous waste facility unless "the waste is treated, rendered, or mixed before or immediately after placement so that the resulting waste, mixture, or dissolution of material no longer meets the definition of ignitable or reactive waste" (40 CFR 264).

c. Incompatible wastes may not be treated or disposed of unless the owner or operator takes precautions to prevent reactions which: (1) Generate extreme heat or pressure, fire or explosions, or violent reactions.

(2) Produce uncontrolled toxic mists, fumes, dusts, or gases in sufficient quantities to threaten human health or the environment.

(3) Produce uncontrolled flammable fumes or gases in sufficient quantities to pose a risk of fire or explosions.

(4) Damage the structural integrity of the device or facility.

(5) Threaten human health or the environment through similar means.

d. The owner or operator of a waste pile must also physically separate any pile containing wastes potentially incompatible with materials stored nearby in containers, open tanks, etc., by means of a dike, wall, berm, or similar means.

e. Chemical composition may also impose some handling/disposal constraints. For example, if the waste material is defined as toxic by the EPA Extraction Procedure Toxicity Characteristic (40 CFR 261.24) or the Acute Hazardous Waste Designation [40 CFR 261.11(2)], special handling or disposal methods may be required. Another impact the design engineer should consider is the potential effect of toxic organic emissions from the treatment/disposal of selected halogenated organic compounds; several states are now considering the elimination of disposal of these materials.

4-3. Waste analysis plan

a. 40 CFR 264, subpart B, requires that owners or operators of all hazardous waste management facilities obtain a chemical and physical analysis of a representative sample of all waste to be managed by their facilities. At a minimum, the analysis must contain all the information necessary to treat, store, or dispose of the wastes properly in accordance with part 264.

b. The analysis may include data from part 261

(Identification and Listing of Hazardous Waste), and existing published or documented data on the hazardous waste or on hazardous waste generated from similar processes. At a minimum the plan must specify: (1) The waste sampling method used to obtain a representative sample.

(2) The parameters selected for laboratory analysis for each waste, including those required in subparts J through Q.

(3) The rationale for selection of these parameters for laboratory analysis.

(4) The methods or procedures applied during laboratory analysis.

(5) The frequency of sampling and analysis to be conducted on subsequent shipments of the same waste to ensure that the analysis is accurate and up to date.

(6) For off-site facilities, the sampling methods and procedures used to identify each movement of hazardous waste to ensure that the wastes are the same as those indicated on the accompanying manifest or shipping paper.

c. 40 CFR 264.13(aX3) requires that the plan be up

dated and changed as needed to remain accurate.

d. The waste analysis plan must include analytical methods to determine ignitability (section 261.21), reactivity (section 261.23) and incompatibility (appendix V, part 264) with respect to the disposal/treatment method. Section 264.17 gives the general requirements for handling these types of wastes and outlines waste constituent constraints which should be considered in developing the waste analysis plan.

e. Each facility also has unique identification (analysis) requirements which would be contained in the waste analysis plan. For example, a "trial test" is required whenever a "substantially different" waste or process is introduced to a surface impoundment; land treatment and landfill operations require the owner/operator to obtain information on the composition, characteristics, and mobility of the wastes to determine the extent of closure and post-closure care which will be necessary to protect human health and the environment.

f. Analytical methods, to ensure compliance with the regulatory requirements, are contained in EPA SW-846.

**CHAPTER 5
LAND DISPOSAL/LAND TREATMENT OPTIONS**

5-1. Introduction

a. This chapter of the manual presents a general discussion of landfills, surface impoundments, land treatment, deep well injection and waste piles with respect to:

- Wastes Suitable for Disposal
- Limitations of Each Disposal Option
- Disposal Procedures
- Design Elements
- Equipment

b. The treatment of each of these topics is brief, focusing on the needs of the design engineer. Where appropriate, reference has been made to source documents for additional information on these topics. With respect to design elements, this chapter summarizes the elements required for each of the five disposal options at Army installations. Since these elements constitute the key design tools for meeting RCRA requirements for hazardous waste land treatment/disposal facilities, they are treated in detail in chapter 6.

c. Table 5-1 lists the design elements required for DA land disposal/land treatment facilities and refers to the sections of the manual where these are discussed in detail. Figure 5-1 presents a conceptual layout of a hazardous waste facility master plan with landfill, surface impoundment, land treatment, and waste pile units.

d. The design engineer should be familiar with closure requirements for a given unit; therefore, these are

included in this chapter for each disposal option under the section on Design Elements. Closure standards, mandated by 40 CFR 264, subpart G, are designed to extend protection of human health and the environment beyond the active life of a facility.

e. As defined by RCRA, each of the disposal options has characteristics that distinguishes it from the others; however, as noted below, some overlapping in definition occurs with landfills and surface impoundments. The RCRA definitions of these five disposal options are summarized below.

(1) A landfill is defined in 40 CFR 260.10 as a disposal facility or part of a facility where hazardous waste in bulk or containerized form is placed in or on land, typically in excavated trenches or cells. However, DA hazardous waste landfills must not accept bulk liquids or sludges with leachable liquids.

(2) A surface impoundment, according to 40 CFR 262.10, is a facility (or part of a facility) that is a natural topographic depression, man-made excavation, or diked area formed primarily of earthen materials (although it may be lined with man-made materials) designed to hold an accumulation of liquid wastes or wastes containing free liquid. According to this definition, a surface impoundment is assumed to have a fluid surface and hold non-containerized free bulk liquids. Examples of surface impoundments are holding, storage, settling, and aeration pits, ponds, and lagoons. Surface impoundments can be classified as disposal, storage or treatment facilities, as follows:

Table 5-1. Design Features Required by RCRA For DA Land Disposal/land Treatment Facilities^a

Facility Elements	Reference ^b	Disposal/Land Treatment Facilities			Landfills
		Surface Impoundments	Waste Piles	Land Treatment	
Liner System C	6-3	Required	Required	NA	Required
Leak Detection System	6-4	Required	Required	NA	Required
Monitoring Wells	8-3	Required	Required	Required	Required
Leachate Collection and Removal Systems	6-4	NA	Required	NA	Required
Run-on/Run-off Controls	6-5	Required	Required	Required	Required
Wind Dispersal Controls	6-8	NA	Required	Required	Required
Overtopping Controls	6-8	Required	NA	NA	NA
Cap (Final Cover)	6-7	Required (disposal)	NA	NA	Required
Closure and Post-Closure Care	5-2, 5-3, 5-4	Required (disposal)	NA	Required	Required

^a Injection wells are excluded from this table since their design features are unique. See paragraph 5-5 of this manual.
^b Paragraph(s) in this TM describing the design feature.
^c Double liners are required at all DA installations unless a waiver is obtained from HQ, (DAEN-ECE-G), Washington, DC 20314
 US Army Corps of Engineers.

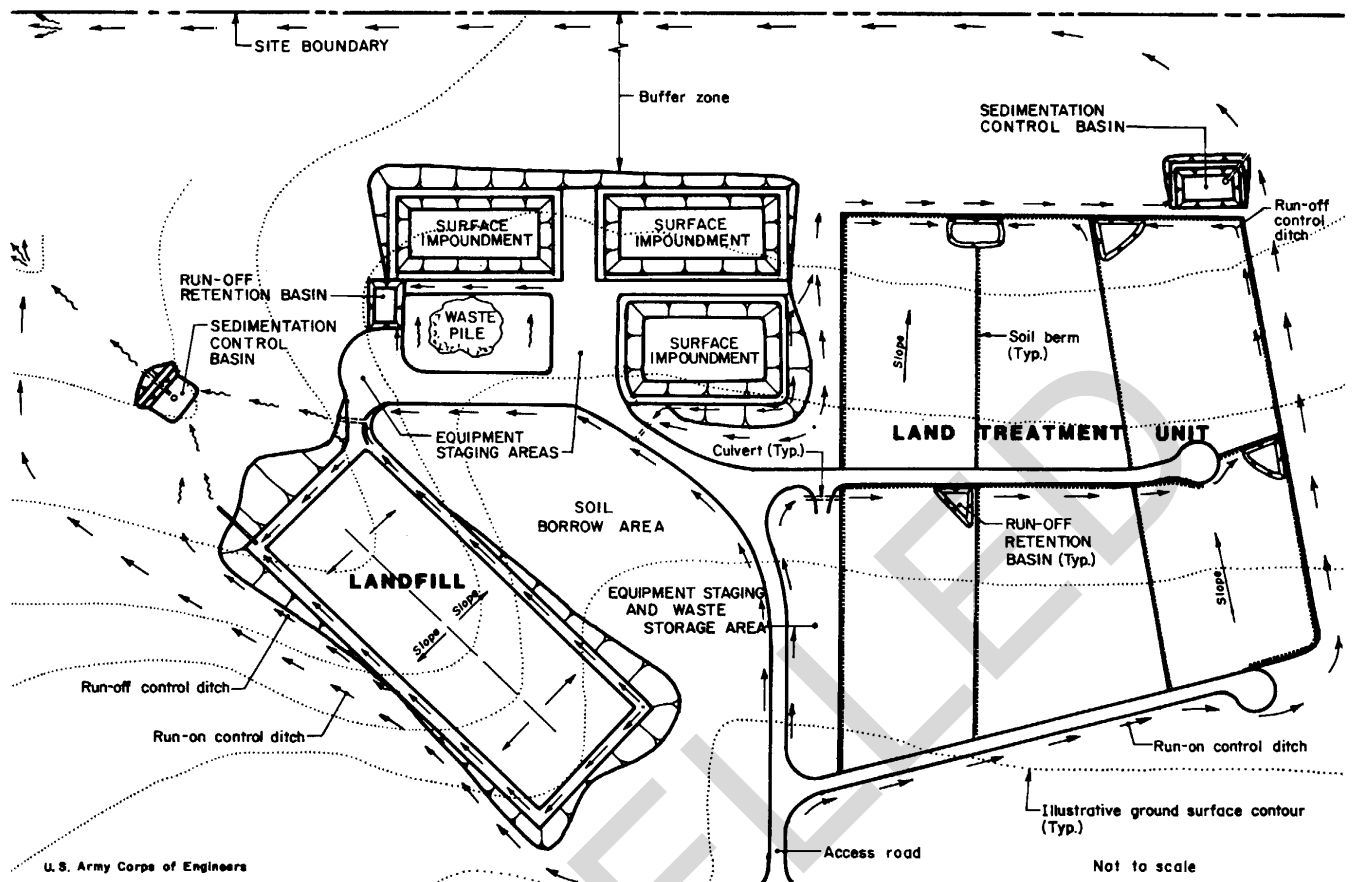

Figure 5-1. Illustrative hazardous waste master plan.

(a) Disposal-Hazardous wastes remain after closure.

(b) Storage-Wastes are held for a temporary period and removed at closure.

(c) Treatment-Wastes are modified physically or chemically to render them less toxic, mobile, or otherwise less hazardous.

(3) A land treatment unit is a facility or part of a facility at which hazardous waste is applied onto or incorporated into the soil surface. As provided in 40 CFR 264, subpart M, a waste must not be land treated unless the hazardous constituents in the waste can be degraded, transformed or immobilized in the treatment zone (ranging up to 5 feet in depth). Units designed primarily for the purpose of dewatering without treatment are considered surface impoundments rather than land treatment units. Land treatment units are unlike other land disposal units in that they are not designed and operated to minimize all releases to ground-water; rather, they are open systems that allow liquids to move out of the unit.

(4) Underground injection is the subsurface emplacement of fluids through a bored, drilled, or driven well, or through a dug well, wherein the depth of the dug well is greater than the largest surface dimension. Septic tanks or cesspools used to dispose of hazardous waste have been specifically included in the RCRA definition of injection well.

(5) A waste pile is any non-containerized accumulation of solid, non-flowing hazardous waste that is used for treatment or storage; however, waste piles may not be used to intentionally dispose of wastes. If the owner or operator of a waste pile wishes to dispose of wastes, he must apply for a landfill permit and manage the pile as a landfill. Piles are generally small, and many are in buildings or maintained outside on concrete or other pads. They are frequently used to accumulate waste before shipment, treatment, or disposal and are typically composed of a single dry material.

5-2. Landfills

a. *Suitable wastes.* The primary restriction on landfilling of hazardous wastes is the elimination of liquid disposal. Bulk liquids or sludges with leachable liquids must not be landfilled at DA hazardous waste facilities; disposal of such wastes will be permitted only in surface impoundments. RCRA regulations permit disposal of small quantities of liquids in small containers in an overpack drum (lab pack), provided that the latter contains sufficient absorbent material to absorb all of the liquid contents of the inside containers. The inside containers must be non-leaking and compatible with the contained waste. The overpack drum must be an open head DOT-specification metal shipping container of no more than 110-gallon capacity. Batteries,

capacitors or similar non-storage containers which contain free liquids may not be landfilled. Acutely hazardous wastes such as carcinogens must be solidified prior to disposal, regardless of their quantities.

b. *Disposal constraints.* Landfills should be sited in a hydrogeologic setting that provides maximum isolation of the waste from ground-water. This is achieved by vertical separation of wastes from the uppermost ground-water, and low permeability of the subsurface material providing the hydraulic separation. In addition, the landfill must be located above the 100-year flood level and not interfere with major surface drainage.

(1) Ideally, the soils in the area should be suitable for daily cover as well as final cover. In cold regions where frost penetration is significant (3 to 6 feet), the cover material should be stockpiled and maintained in as dry a condition as possible to facilitate wintertime operations.

(2) Location of landfills in karst terrain (or similar geologic formations) and in seismic zones 3 and 4 (as defined in TM 5-809-10) should be avoided whenever possible. However, if landfills are sited in such areas, the following precautions should be taken:

(a) An extensive geological investigation must be performed to ensure that the facility is not located on or in the near vicinity of sink holes or caverns and that the soil and rock in the area are suitable for location of this type of facility.

(b) After the final site selection has been completed, USACE (DAEN-ECE-G) shall be notified of proposed location and geological conditions. This notification shall be made a minimum of 30 days before design begins.

c. *Procedures.* Disposal by landfilling involves placement of wastes in a secure containment system that consists of double liners, a leak detection system, a leachate collection system and final cover. Wastes delivered to the landfill are unloaded by forklift or front-end loaders and placed in the active waste lift. Hazardous materials shall be segregated in cells or subcells according to physical and chemical characteristics to prevent mixing of incompatible wastes. Following their placement, the hazardous wastes are covered with sufficient soil to prevent wind dispersal. Successive lifts are placed and the cover soil graded so that any direct precipitation is collected in a sump. All direct precipitation collected in the sump is tested for contamination. As filling continues, wastes are placed so as to direct any run off toward a temporary sump at the lower segment of the base liner. For operations during extremely wet conditions, tarps may be used to cover the active area to minimize infiltration of rainfall. In high rainfall regions, semi-permanent roof/rainfall protection can be installed over the entire cell using either rigid or stress-tensioned structures

The structure should be designed to prevent all rainfall from entering the cell until final cover is completed; then it is dismantled and erected over the next cell. Another alternative to operations during extremely wet weather is to containerize or store wastes until the rainfall season is over. As areas of the secure landfill are filled to final grade, a final soil cover is installed in accordance with the facility's operation plan. Figure 5-2 illustrates a typical landfill operations plan.

d. The major design elements of hazardous wastes landfills, discussed in detail in chapter 6, are:

- Double liners
- A leak detection system between the liners
- A leachate collection and removal system above the liner
- Run-on and run-off control systems
- A final cover to minimize infiltration of precipitation into the closed landfill

(1) The base liner system is designed and constructed to prevent migration of wastes during the active life of the disposal unit into the liner, and out of the landfill into subsurface soil, ground-water or surface water. A leak detection system between the double liners enables the detection and removal of any seepage, and evaluation of liner performance.

(2) Located above the double liners is the leachate collection and removal system, which consists of slotted drainage pipes designed to collect leachate that flows under the influence of gravity to low points within the landfill. The leachate collection and removal system must be designed and operated to ensure that the depth of leachate over the liner does not exceed 1 foot.

e. *Closure.* Closure of a landfill is achieved by installing a final cover which has a permeability less than or equal to that of the bottom liner. The cover should be capable of (1) minimizing infiltration of liquids, (2) functioning with minimum maintenance, (3) promoting drainage and minimizing erosion of cover, and (4) accommodating settling and subsidence.

f. *Equipment needs.* Secure landfills require equipment for (1) handling wastes and cover material, (2) performing support functions, (3) spill and fire control, and (4) decontamination. For waste handling, a forklift and a front-end loader are typically used to unload and place containers and solid materials in assigned active waste lifts. Dozers and self-loading scrapers are used to spread and compact cover material. For grading final surfaces, the crawler dozer is effective; it can economically doze earth over distances up to 300 feet. Scrapers can haul cover material economically over relatively long distances (more than 1, 000 feet). Since construction equipment is heavy when loaded, precautions must be taken in placing initial lifts of wastes over the base liner. Subsequent lifts of bulk wastes and soil cover should be consoli-

dated by compactors to minimize settlement.

(1) Support equipment for a secure landfill may include a road grader, water truck, pickup trucks and vacuum trucks. The road grader can be used to maintain dirt and gravel roads on the site, to grade the soil cover, and to maintain any unlined drainage channels surrounding the fill. Water trucks range from converted tank trucks to highly specialized, heavy vehicles that are generally used in road construction operations. They are used at the landfill for construction, to control dust, and if necessary, fight fires.

(2) In accordance with 40 CFR 264.32, all facilities must be equipped with communication or alarm systems, fire control equipment, spill control equipment, and decontamination equipment (unless an exemption is obtained from the EPA Regional Administrator [RA]). Paragraph 7-1 describes procedures and equipment required for facility contingency plans.

(3) All equipment used to unload and place wastes must be decontaminated before being taken out of the disposal operation and staging area. Incoming vehicles not used in the unloading operation should be restricted to staging areas, or clean soil areas within the landfill.

5-3. Surface Impoundments

a. Wastes suitable for impoundments. Surface impoundments are used for the evaporation and treatment of bulk aqueous wastes. Typical DA wastes which would be considered appropriate for impoundments include waste acids and rinse water with traces of propellant. Reactive wastes must not be placed in a surface impoundment unless they are made nonreactive and defined in 40 CFR 261.23. Since mixing of wastes is inherent in a surface impoundment, incompatible wastes should not be placed in the same impoundment. The potential dangers from the mixing of incompatible wastes include extreme heat, fire, explosion, violent reaction, production of toxic mists, fumes, dusts, or gases, and damage to the structural integrity of the surface impoundment. Clearly the potential impacts on human health or the environment which could result from such conditions must be avoided.

b. Disposal constraints. Surface impoundments should be located in a hydrogeologic setting that limits vertical and horizontal hydraulic continuity with ground-water. Surface impoundments should be sited and designed with maximum protection of groundwater provided by liners, and low-permeability underlying soils. The hydraulic head formed in the impoundment provides for a high potential for liquid seepage and subsurface migration. The precautions concerning location of landfills in karst terrain or seismic zones 3 and 4 also pertain to surface impoundments (see para 5-2b(2)).

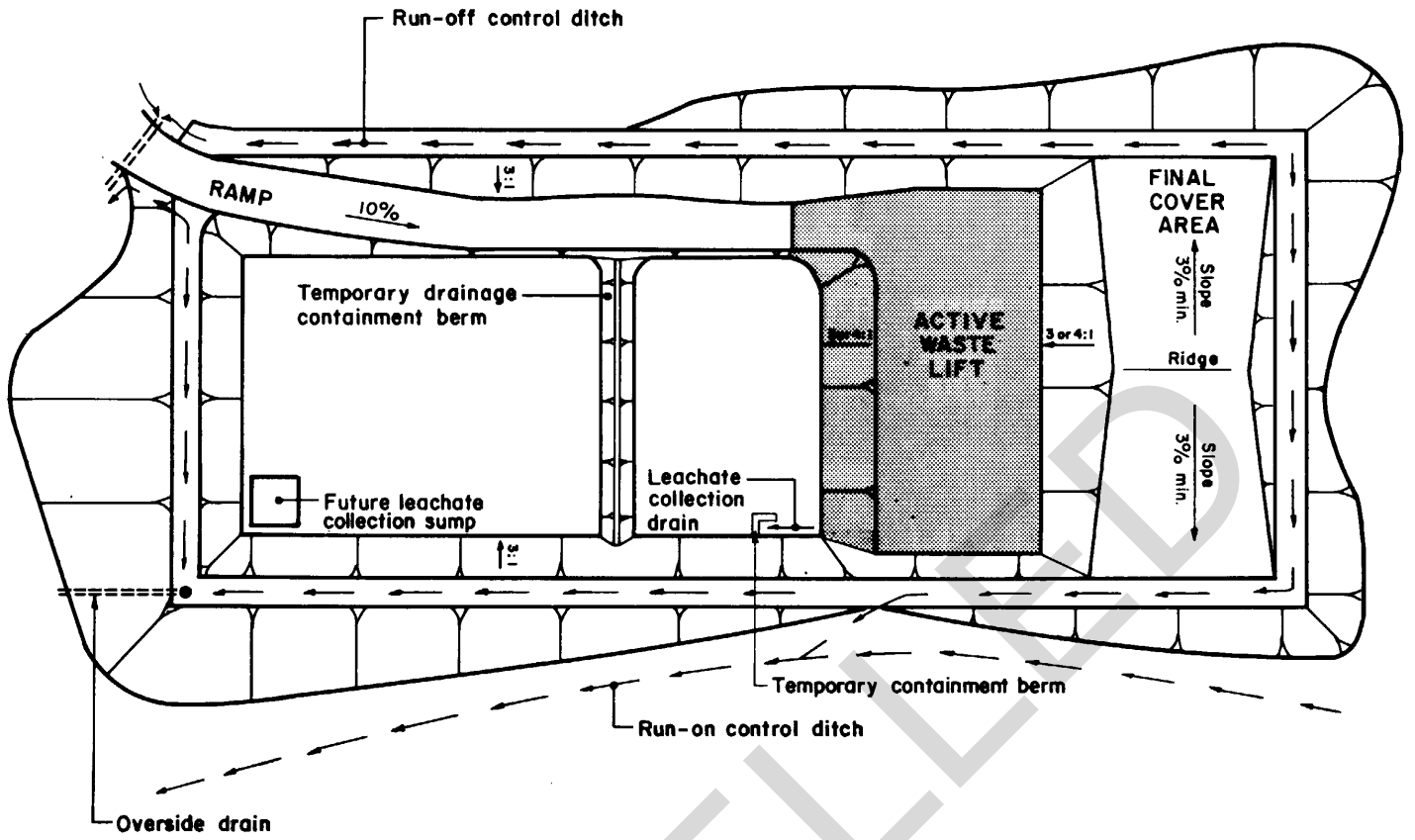

Figure 5-2. Landfill operations plan.

c. Procedures. Impoundment of hazardous waste involves disposing of liquid wastes in a man-made excavation or diked area that ranges in surface area from tenths to hundreds of acres. Wastes are typically delivered to the impoundment by pipe systems or bulk tankers which offload into the impoundment at a "discharge apron."

(1) During the time that the liquid wastes are impounded, operations include, but are not limited to, the following inspection activities:

- Monitoring to ensure that liquids do not rise into the freeboard (prevention of overtopping)
- Inspecting containment berms for signs of leakage or erosion
- Periodic sampling, if needed, of the impounded wastes for selected chemical parameters
- Inspecting periodically for floral and faunal activities (such as animal burrows) that could cause leaks through earthen dikes, levees or embankments
- Monitoring of leak detection systems

(2) The major operations at an impoundment involve "removal" of the liquid waste. There are a number of different methods for removing liquid wastes; each method must be implemented in accordance with the standards described in this manual. Waste removal methods include:

(a) Decanting-Liquids within or ponded on the surface of the impoundment can be removed by gravity flow or pumping to a treatment facility if there is not a large percentage of settleable solids.

(b) Pumping and settling-Liquids or slurries composed of suspended or partially suspended solids can be removed by pumping into a lined settling pond and then decanting. Sludges are disposed of in a dry state, and either returned to the impoundment or disposed of in another contained site.

(c) Solar drying-Liquids are removed by evaporation; sludges remaining after evaporation are left in the impoundment or disposed of in another contained site. Note that volatile organics shall not be handled in this manner.

(d) Chemical neutralization-Aqueous waste with low levels of hazardous constituents frequently lends itself to chemical neutralization and subsequent normal discharge under NPDES permit requirements.

(e) Infiltration-Certain aqueous waste can be handled by infiltration through soil, provided that the hazardous substances are removed by either soil attenuation or underdrain collection of the solute. Collected solutes are usually treated.

(f) Process reuse-Some aqueous waste can be recycled in the manufacturing process a number of times until the contaminants are at a level requiring disposal by one of the methods previously mentioned.

Reuse does not dispose of the waste but can significantly reduce the quantities requiring disposal.

(g) Addition of Absorbents-Materials can be added to aqueous impounded wastes to absorb free liquids. Absorbents include fly ash, kiln dust and commercially available sorbents. The designer should avoid selecting biodegradable absorbents such as straw or rice, since they can decompose, resulting in the formation of landfill gas, or contribute to void space, which might lead to subsidence.

(3) Cleaning and closure processes normally involve removal of waste residuals from the impoundment. Removal methods for settled residues and contaminated soil include removal of the sediment as a slurry by hydraulic dredging; excavation of the sediments with a jet of high-pressure water or air; vacuum transport of powdery sediments; or excavation of hard solidified sediments by either dragline, front-end loader or bulldozer. Sediments removed by one of these methods may require dewatering to comply with EPA guidelines for disposal.

(4) When residual wastes will be left in the impoundment at closure (e.g., the impoundment is used for disposal), the wastes must be stabilized to a bearing capacity sufficient to support the final cover. Typically, stabilization is achieved by either passive (evaporation) or active dewatering. Active processes, including mechanical dewatering or thermal drying, are described in EPA SW-873.

d. Design elements. Basic design requirements for surface impoundments mandated by 40 CFR 264 include:

(1) Double liners with a leak detection system and monitoring wells to prevent wastes from migrating into subsurface soil and ground water and surface water during the active life of the site (see figures 6-2 and 6-5).

(2) Prevention of overtopping the sides of the impoundment.

(3) Construction specifications that ensure the structural integrity of dikes.

e. Closure. As specified in 40 CFR 264, a surface impoundment can be closed in one of two ways: (1) Removing or decontaminating all wastes, waste residues, system components (such as liners), subsoils and structures or equipment. No post-closure care is required as long as removal or decontamination is complete.

(2) Removing liquid waste or solidifying the remaining waste. A final cover will be placed over the closed impoundment. Post-closure care will consist of monitoring ground-water and conducting corrective action if it is warranted (see para 8-5), and maintaining the effectiveness of the final cover. For a doublelined disposal unit, the leak detection system will be monitored as part of post-closure care.

f. *Equipment needs.* Equipment for surface impoundments includes that needed for

- Removal of liquid from the impoundment.
- Removal of settled residuals and contaminated soil.
- Dewatering sediments prior to their final disposal.
- Solidification and stabilization of residual wastes.

(1) At the time of closure, impounded liquid can be removed by a number of methods described in paragraph 5-3c; typical equipment used for this purpose is a centrifugal pump or a hydraulic pipeline dredge. Waste residuals can be removed by means of a vacuum truck to pump slurried sediment from the impoundment, a rotary cutter to remove hardened sediments that do not flow freely, or a dragline or front-end loader to excavate hard, solidified sediments. To dewater sediments, filter presses may be used to produce a nonflowable solid.

(2) Any equipment used for liquid sediment removal or dewatering must be decontaminated before being taken out of the disposal operation area.

5-4. Land Treatment

a. *Suitable Wastes.* Land treatment is potentially a cost-effective method of disposing of industrial wastes such as bulk organic sludges that have a high water content. A variety of industrial wastes, effluents, sludges and solid wastes are suitable for treatment and disposal by the land treatment method, including those containing or derived from hazardous constituents listed in appendix VIII of 40 CFR 261. However, for wastes that contain very high concentrations of toxic organics, a disposal method other than land treatment is required.

(1) Hazardous waste land treatment facilities must include plans for conducting a treatment demonstration and reporting the complete demonstration results. The objective of the demonstration is to establish the operating practices that will completely degrade, transform or immobilize hazardous constituents. Regardless of the demonstration method selected, the following criteria must be met:

- Accurate simulation of the characteristics and operating conditions of the proposed treatment unit, including
 - waste characteristics
 - climate in the area
 - regional topography
 - soil characteristics and depth of the treatment zone
 - operating practices to be used
- Complete degradation, transformation, or immobilization in the treatment zone of the hazardous constituents in the waste

- Operation of the land treatment unit in a manner that protects human health and the environment

(2) Additional information on conducting a treatment demonstration, selecting appropriate field tests, and designing test procedures for the demonstration is presented in EPA SW-874.

(3) Special requirements for ignitable or reactive wastes and for incompatible wastes are contained in 40 CFR 264.281 and 264.282. Ignitable and reactive wastes must be immediately incorporated into the soil so that they are no longer considered ignitable or reactive. They must also be protected from any material or condition that could cause ignition or reaction. Incompatible wastes, such as those listed in appendix V of 40 CFR 264, may not be placed in the same treatment zone unless precautions are taken to avoid fires, explosion and violent reactions, the generation of heat and pressure, the production of toxic mists, fumes and gas, or the creation of other conditions that might threaten human health or the environment. Federal regulations (40 CFR 264.276) also outline special requirements for application of cadmium and other hazardous wastes to lands used for growth of food-chain crops.

b. The land treatment option is limited by (1) the availability of sufficient quantities of usable land, (2) the assimilative capacity of the plant-soil system, (3) regulatory restrictions concerning food-chain crops, and (4) environmental conditions.

(1) The availability of sufficient quantities of usable land is dependent upon a number of additional limiting factors, including the application rate and regulatory requirements specifying the depth of the treatment zone.

(a) The application rate is dependent not only on the waste constituent, but also on the assimilative capacity of the soil (see EPA SW-874). While it is theoretically possible to specify land application rates and required land areas for most wastes, in practice, the complete degradation, transformation or immobilization of some constituents would require application over such large tracts of land that land treatment would not be cost-effective. Economic factors might therefore preclude land treatment of some wastes.

(b) With respect to the treatment zone, EPA regulations require that the zone which wastes are introduced be no deeper than 5 feet and that there be a 3-foot separation between the bottom of the treatment zone and the seasonal high water table. These requirements could limit land treatment in certain areas.

(2) The second factor limiting the land treatment option is the assimilative capacity of the plant-soil system to handle a particular hazardous waste; this is a complex limiting factor due to the large number of variables within the system. Among these are the physical, chemical, and biological properties of the

particular soil, the compatibility of the soil and the waste to be treated, and the capacity of the soil to receive and transmit water (hydraulic capacity). These variables are described in detail in Overcash, 1981, a definitive text on land treatment. In addition to identifying the factors limiting land treatment as a disposal option, Overcash presents detailed procedures for the design of land treatment systems for all waste types.

(3) The third limiting factor, regulatory restrictions concerning food-chain crops, is also complex. For most hazardous constituents, RCRA stipulates that there can be no uptake by food-chain crops and no greater concentration of the constituents in the crop than is found in the surrounding area. As summarized in 40 CFR 264.276, the owner/operator of a land treatment unit must demonstrate that there is no "substantial risk to human health caused by the growth of such crops in or on the treatment zone."

(a) This objective may be met either by demonstrating that hazardous constituents will not be transferred to food or feed portions of a crop, or will not occur in greater concentrations in or on identical crops grown on untreated soils under similar conditions in the same region. Both of these options require that the following be addressed: crop uptake, physical adherence to the crop, and direct ingestion of contaminated soil by grazing animals.

(b) With respect to hazardous wastes containing cadmium, even more restrictive limitations apply. If such wastes are to be land treated, the following criteria must be met:

- A pH of at least 6.5
- An application rate of no more than 0.44 lb/acres/yr
- Limits on cumulative application, as dictated by the soil's cation exchange capacity
- Special conditions for animal feed (specific details are outlined in 40 CFR 264.276)

(4) The last limiting factor, environmental conditions, actually refers to a number of natural features that restrict the siting of a land treatment unit. The precautions concerning location of landfills in karst terrain or seismic zones 3 and 4 also pertain to land treatment facilities (see para 5-2b(2)). In general, limiting environmental conditions should either be avoided or should serve as design constraints in developing the facility layout. These include:

- Hydrogeologic Conditions
 - Bedrock outcrops
 - Irregularities such as fissures or faults
 - Aquifer recharge zones
 - Flood-prone areas such as river flood plains
 - Wetlands
 - Karst terrain
 - Seasonally high water tables (< 4-6 ft)

- Proximity to private or community water supply wells or reservoirs
- Climate
 - Location upwind of large populations
 - Extremely wet or cold conditions
- Topography -Steep slopes -Broken terrain
- Soils
 - Thin soil above ground-water
 - Saline soils
 - Highly permeable soils above shallow ground water
 - Soils with extreme erosion potential
- Land use -Areas formerly used for landfills
 - Areas contaminated with persistent residues from past chemical spills or waste treatment processing

c. *Procedures.* Land treatment is both a method of disposal and a treatment mechanism. It involves applying a waste to land and incorporating it into the soil, where it undergoes biochemical action which attenuates its negative impact on the environment. A number of techniques are available for applying the waste, depending largely on the wastewater content, but also hinging on such considerations as soil properties, topography and climate.

(1) For land application purposes, wastes are generally classified as

- * Liquid (less than 8 percent solids, with particle diameters less than 1 inch)
- * Semiliquid (8 to 15 percent solids and/or particle diameters greater than 1 inch)
- * Solid (greater than 15 percent solids)

(2) Application of liquid wastes is generally accomplished by either spraying the waste on the land with sprinklers or by using flood or furrow irrigation techniques. Semiliquid sludges are normally applied by surface spreading, with subsequent incorporation into the soil, or by subsurface injection 4 to 8 inches below the soil surface. Low-moisture solids are spread on the surface and later incorporated into the soil (figure 5-3).

(3) Waste volatility, site terrain and weather conditions may dictate the choice of other application techniques, regardless of the water content of the waste. For example, highly volatile wastes should not be applied by irrigation or surface spreading, but be injected at least 6 inches below the soil surface. On steep slopes or in freezing weather, alternatives to spray irrigation will likewise be required. The objectives in any land treatment system, regardless of method used, are uniform application of wastes, and use of application rates within the assimilative capacity of the soil.

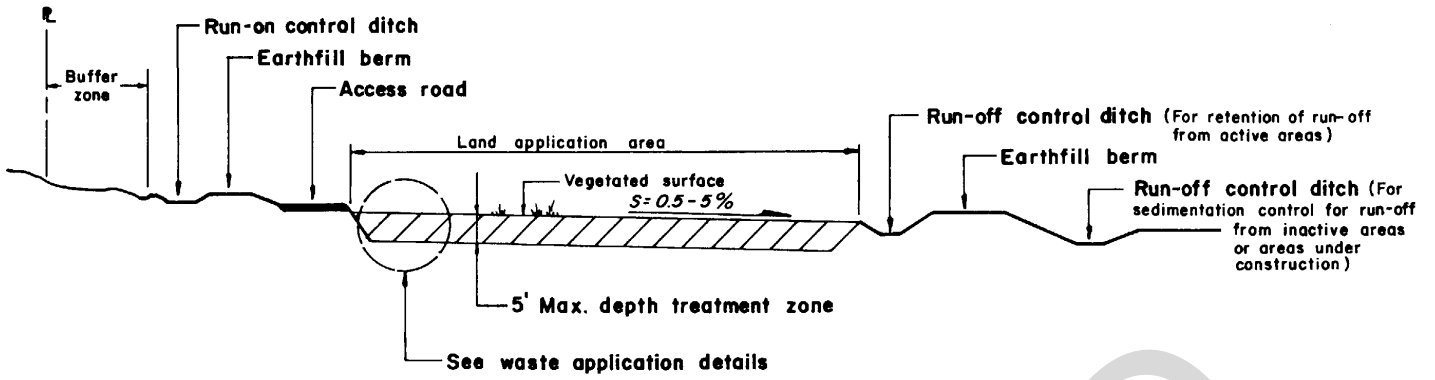

TYPICAL SECTION FOR A LAND TREATMENT AREA

(Fixed position type shown)

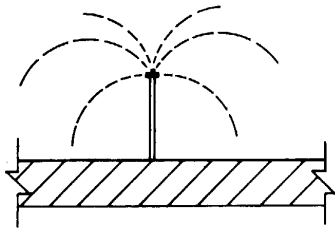

SPRINKLER IRRIGATION

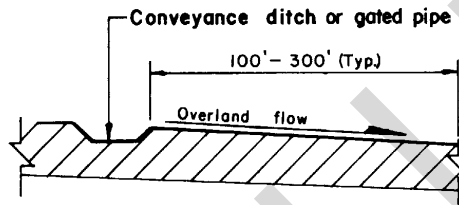

SURFACE IRRIGATION

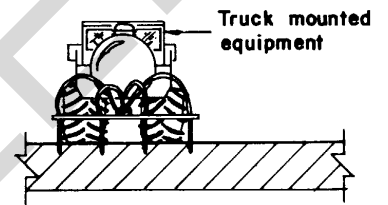

SEMI-LIQUID INJECTION

TYPICAL WASTE APPLICATION DETAILS

Not to scale

Figure 5-3. Land treatment area details.

d. Design elements. Design requirements, as well as requirements for construction, operation and maintenance, of a land treatment facility are specified in the facility permit to ensure compliance with regulations. The design goal must be to maximize the degradation, transformation or immobilization of hazardous constituents in the specified treatment zone, in accordance with all design and operating conditions used in the treatment demonstration; and minimize both runoff of hazardous constituents from the treatment area and inflow of water into the treatment area.

(1) Fulfillment of these specific design requirements, as well as meeting the principal design goal of nondegradation of the land, requires a number of steps, including analysis of the waste stream and site soil characteristics, evaluation of waste-soil interactions and site assimilative capacity, determination of application rate, selection of an application method, and layout of the facility and control structures.

(2) 40 CFR 264.278 of RCRA requires an unsaturated zone monitoring program for all land treatment units to determine whether hazardous constituents have migrated below the treatment zone. Soil and soil pore liquid must be monitored on a background plot and immediately below the treatment zone. If any migration is detected, the owner/operator of the land treatment unit must notify the EPA Regional Administration (RA) of this finding within seven days. Within 90 days the owner/operator should recommend modifications to the facility permit that will maximize treatment of hazardous constituents within the treatment zone.

(3) There are several possible configurations for a land treatment facility, including single cell, rotating cell and progressive cell configurations. In the single cell configuration a waste is applied uniformly over the required acreage without subdividing the land treatment area. In the progressive cell configuration (figure 5-3), the land treatment unit is subdivided into cells or areas which are treated sequentially, cultivated and revegetated.

(4) Adequate buffer zones should be provided between the land treatment unit and property boundaries to minimize odor problems, permit easy access to water retention facilities, and allow implementation of contingency measures to control unusual runoff.

(5) To protect ground-water, surface waters and off-site property, water management facilities must be designed and coordinated with application method and facility configuration. The amount of water which contacts treatment areas (run on) must be minimized, and run off from treated areas must be collected and treated prior to discharge, unless it is free of contamination from hazardous wastes. Two types of structures are needed: (1) diversion structures, which either intercept clean run on and divert it around the treatment

area or prevent contaminated water from leaving the unit by directing it to a retention basin; and (2) run-off retention and sedimentation control basins (figure 5-4). In addition, tanks, surface impoundments, or waste piles may be needed for waste storage during inclement weather. For example, land treatment facilities in cold regions may require storage facilities, particularly if the application season is limited to spring, summer, and fall. A water balance may be performed to aid in design of such facilities. Subsurface drainage systems and leachate control and treatment systems may also be required at some hazardous waste land treatment facilities.

e. Closure. Closure of a land treatment unit may be accomplished by either establishing a permanent vegetative cover capable of maintaining growth without extensive maintenance, removing and landfilling the zone of incorporation, or capping the land treatment area to control wind and water erosion. General closure practices called for include minimizing run-off from the treatment zone, continuing ground-water monitoring, and continuing restrictions on food-chain crops. In addition, the unsaturated zone should be monitored as part of the closure procedures; however soil-pore liquid monitoring may be suspended 90 days after the last application of waste at the unit. Each of these practices is described in chapter 12 of EPA SW-874.

f. Equipment needs. Equipment required for a land treatment operation ranges from the simple to the sophisticated, depending on the application technique employed. However, all are conventional and readily available. Any equipment used for operations must be decontaminated before taking from the treatment unit

(1) For surface irrigation by furrow or flood techniques, piping and a pump are needed to transmit the waste to the point of discharge. Alternatively, a truck or trailer-mounted tank may be used to apply wastes by gravity flow or through a sprayer or manifold. Equipment needs for sprinkler systems will vary, depending on system type, but will generally require properly sized piping, pump, nozzles.

(2) A vacuum truck with flotation tires and rear sprayer or manifold may be used for surface spreading of sludge. If the sludge is too thick to be pumped, a conventional truck with moisture-proof bed may be used to dump the waste, which is then spread with a road grader or bulldozer. The blades of both road graders and bulldozers should be equipped with depth control skids and edge wings to aid in uniform application. Once the waste has been spread on the land, there are several types of equipment that can be used to incorporate the waste into the soil-moldboard plow, disk, and/or rotary tiller. Similar equipment can also be used for low-moisture solids. A spreader can also be used to apply solids which tend to be sticky or chunky.

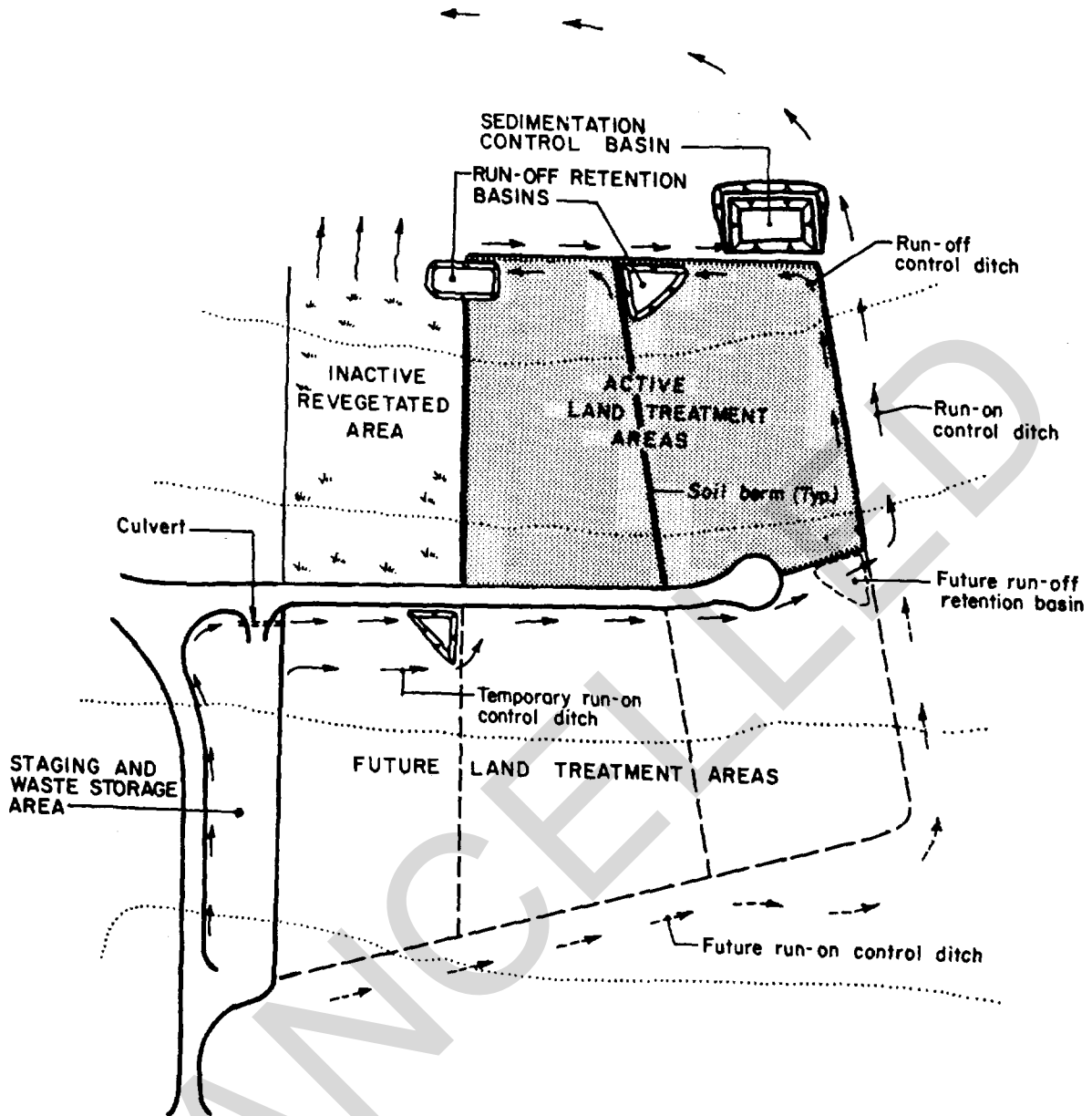

Not to scale

Figure 5-4. Land treatment operations plan.

(3) Basic equipment for subsurface injection of wastes consists of a truck or tractor with two or more chisels attached. Adjustable sweeps are mounted near the bottom of the chisels to open a wide but shallow underground cavity. Waste is injected into the cavity through a tube attached to the back of the chisel. For repeated application of wastes over long time periods, underground supply pipes may be installed, with flexible tubing used to connect the supply pipe to truck or tractor-mounted injectors.

5-5. Deep Well Injection

a. *Suitable Wastes.* Injection wells are used to dispose of large quantities of liquid hazardous wastes into the subsurface. Injection well disposal is regulated by the EPA Underground Injection Control Program (UICX40 CFR 146) and authorized by subpart C of the Safe Drinking Water Act. Currently injection wells may accept large quantities of chemical, waste-water brines or mining wastes in deep, isolated porous geological formations. Large volumes of waste, on the order of hundreds of thousands or millions of gallons, may be disposed by injection. Approximately 160 injection wells are now operating, with most used by the chemical and petrochemical industry.

(1) A wide variety of wastes can be disposed by injection. These wastes include, but are not limited to:

- Dilute or concentrated acid or alkaline solutions
- Solutions containing metals
- Inorganic solutions
- Hydrocarbons and chlorinated hydrocarbons
- Solvents
- Organic solutions with a high biochemical oxygen demand

(2) The UIC criteria and standards cover construction, operating, plugging and closure of deep wells, and monitoring and reporting requirements. The UIC classification of injection wells is as follows:

Class I	- Injects hazardous wastes as defined in 40 CFR 146, subpart A
Class II	- Injects petroleum fluids or byproducts
Class III	- Injects fluid for mineral extraction
Class IV	- Injects fluids into or above an underground drinking water source
Class V	- Injects fluids not covered in Classes I-IV

b. *Disposal constraints.* The injection well disposal option is limited by

- regulations and policy
- waste types
- selective geological environment
- construction and operation expense

(1) Most importantly, injection wells are considered by EPA policy to be a "last resort" means of disposal. It must be demonstrated that the injected fluids will not contaminate ground-water or damage the environment, and injection is used after all other means of disposal are found unsatisfactory.

(2) In addition, types of wastes to be disposed of may limit disposal options: only liquid wastes may be disposed of in injection wells. Injected wastes are strictly covered in UIC; justification for injection must be presented and pretreatment of waste streams may be required prior to injection.

(3) To ensure their separation from drinking water aquifers, injection wells are limited to sites that are in geologically isolated environments. Extensive geologic research and field work must be done to site wells and to determine injection zone isolation. Injection horizons must be tested for waste compatibility to ensure that the wastes do not contain materials that are chemically reactive with site soils or rock. Waste constituents that could pose problems include corrosive mineral salts, acids (capable of dissolving carbonate rock), and precipitated salts. In addition, the proposed injection area should be tested for overall permeability to define the injection zone. Typical siting investigations and well developments and construction information is found in comprehensive technical documents (EPA 600/2-77-240).

(4) Another disposal limitation is the existence of unexpected subsurface problems such as pressure around the formation, induced earthquake activity and dissolution of injection zone host rock. The precautions concerning location of landfills in karst terrain or seismic zones 3 and 4 also pertain to injection wells (see para 5-2b(2)). Pressure mound formation may result in a "mound" of injected fluid that forms near the injection well hose and interferes with rates of fluid injection and ground-water flow. Low magnitude earthquake swarms may be caused by injecting fluids into deep fault zones; such a case was documented at Rocky Mountain Arsenal in the 1960's. Finally, host rock may dissolve if it is incompatible with the injected waste, thereby creating voids at depth and possible subsidence effects.

(5) Worst of the subsurface problems is aquifer contamination as a result of injection. Contamination could occur as a result of incompletely plugged abandoned injection wells, displacement of saline water into potable water, or well bore failure.

(6) Finally, the substantial costs of implementing injection well disposal systems are a significant limiting factor; these systems require much professional expertise in site evaluation, testing, construction and waste stream analysis. Furthermore, the system requires stringent monitoring and maintenance to ensure good operation. Costs for typical Class I-EI type

wells may easily range into the hundreds of thousands of dollars.

c. Procedures. Wastes are disposed in injection wells by injecting waste under pressure to porous injection zones. Following their collection, wastes may be pretreated and then sent into the pressurized system. Injection may proceed round the clock, so that large volumes may be disposed of continuously. The injection well system consists of a cased and sealed borehole containing the injection tube; wastes are forced through the tube to the injection zone. Use of a tube for injection helps reduce the possibility of leaks; a tube may be replaced easily, saving wear on borehole casings (see figure 5-5). All phases of injection are monitored for leakage detection and proper operation. Disposal operations are reported quarterly, so corrective action or adjustments to the system may be made if necessary.

d. Design elements. UIC regulations require all aspects of injection well systems to be reported and classified, including construction requirements that pertain to casing type and cement type, well dimensions, waste characteristics, corrosiveness and leak prevention. The regulations also call for tests and logs, including electric logs on the injection zone formation and integrity of completed wells. In addition, midcourse evaluation of well performance is required for the first two years of operation. In general, all types of materials and procedures must be specifically described or referenced. As an example, steel and concrete corrosion resistance to the waste stream must be demonstrated.

e. Equipment needs. Injection well siting and construction requires specialized equipment, material and professional expertise. Well siting requires an exhaustive review of geology and in-situ formation testing. Injection wells are commonly 1,000 to 5,000 feet deep; therefore, drilling equipment is needed that is capable of reaching that depth. Once the geologic environment has been defined, waste compatibility studies and construction material selection may commence.

(1) Since hazardous and corrosive material will be injected, construction materials must be selected that can handle the waste stream. Concrete mixes and steel casing are chosen for their ability to ensure delivery of waste to the injection zone. Pumps and injection casing are also chosen to handle wastes and maintain injection pressure. The object of design and material selection is to choose non-reactive, non-corrosive material to deliver and isolate wastes in the injection zone only.

(2) Finally, waste pretreatment may be necessary prior to injection. One or more types of wastes may be injected, so the size and function of the facility may vary. Such a surface facility would include impound

ments, filters, clarifiers, sludge collection, pH control and several injection pumps.

5-6. Waste Piles

a. Suitable Wastes. Waste pile storage and treatment is suitable for semi-solid and solid hazardous wastes such as mine tailings. Waste piles may not be used to intentionally dispose of wastes; if disposal is required, the owner/operator must obtain a landfill permit and manage the pile as a landfill. The regulatory standards for management of waste piles requires that the owner or operator take precautions in treating or storing ignitable, reactive or incompatible waste so that it does not ignite or explode, emit toxic gases, damage the contaminant structure or through other like means threaten human health or the environment. Section 264.256 prohibits the placement of ignitable or reactive wastes in a waste pile, unless the waste is made non-ignitable or non-reactive. Reactive wastes may be especially difficult to manage since waste piles are directly exposed to the environment. Incompatible wastes may not be placed on the same waste pile (section 264.257) to ensure prevention of fires, explosions, gaseous emissions, leaching, or other discharge which could result from the contact or mixing of incompatible wastes or materials.

b. Disposal constraints. Waste piles are not an ultimate disposal method; they are intended only for storage or treatment of certain solid hazardous wastes. Given this restriction, the siting criteria for this disposal method are somewhat less stringent than those for landfills or surface impoundments. In general, however, it is preferable that waste piles be located in a hydrogeologic setting that offers sufficient vertical separation of wastes from the uppermost groundwater, and low permeability soils providing the hydraulic separation. The precautions concerning location of landfills in karst terrain or seismic zones 3 and 4 also pertain to waste piles (see para 5-2b(2)).

c. Procedures. As noted above, a waste pile is any non-containerized accumulation of solid hazardous waste collected for treatment or storage; it is not used to intentionally dispose of wastes. Procedures for depositing wastes in such a unit are therefore quite simple: wastes are trucked to the waste pile location, unloaded, and then placed on the pile.

d. Design elements. Basic design requirements for waste piles include:

- Liners with a leak detection system and monitoring wells
- Leachate collection and removal
- Run-on and run-off control
- Wind dispersal control

(1) Liners selected for a waste pile must be adequate to contain wastes until closure. Considerable

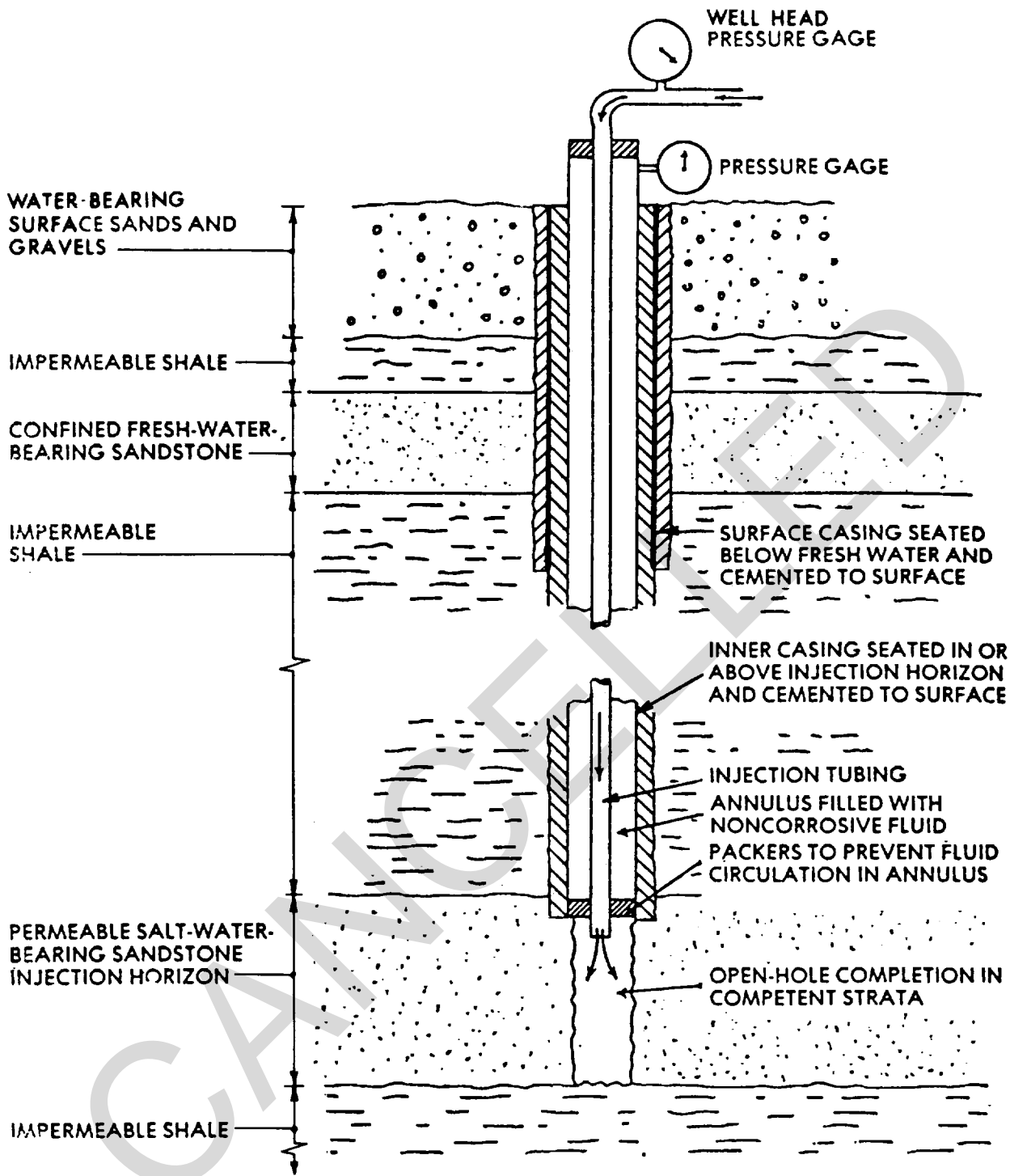

Reproduced from *An Introduction to the Technology of Subsurface Wastewater Injection*, EPA 600/2-77-240, 197 7

Figure 5-5. Deep injection well.

flexibility is permitted in choice of liners, which may, for short-term storage of wastes, be constructed of clay, synthetic materials or admixes. If the waste pile will not be closed for 10 years or more (and cannot be periodically cleaned and inspected for leakage), a double-lined system with leak detection and monitoring wells is required. Details on liner requirements are presented in paragraph 6-3.

(2) A leachate collection and removal system is also required to collect any leachate that may be produced in a waste pile by infiltration of moisture, decomposition or reaction. Leachate systems are discussed in paragraph 6-4. Run-on and run-off control facilities, which are required for waste piles, are addressed in paragraph 6-5.

(3) If the waste pile contains particulate matter, wind dispersal controls are mandated by the regulations. Mechanisms for preventing dispersal of particulate are discussed under special design elements in paragraph 6-9.

e. Closure. Since waste piles cannot be used for permanent disposal of wastes, and can be permitted only for storage, closure requirements are less stringent than for disposal facilities such as landfills. The principal closure requirement for a waste pile which has achieved adequate waste containment during its active life is removal or decontamination of all

waste and waste residue and all system components (e.g., liners), subsoil, structures and equipment which have been contaminated by contact with the waste. However, if contamination of the subsoil is so extensive as to preclude complete removal or decontamination, the closure and post-closure requirements applying to landfills must be observed. Ensuring adequate containment of waste should therefore be an important consideration in initial design of a waste pile.

f. Equipment needs. The type of equipment employed in operation of a waste pile depends to a large extent on the waste characteristics and the size of the pile. With the exception of compactors, many of the vehicles used in landfill operations can also be employed for waste piles. Bulldozers and front end loaders are widely used to place wastes; scrapers can also be used on some applications, particularly where the size of the pile and the coarseness of the waste permit the scraper to deposit wastes over the top of the pile. Large-scale operations may also be able to use conveyor belts or drag lines to deposit the wastes over the pile. Any equipment used to unload and place wastes must be decontaminated before being taken out of the disposal operation area.

CHAPTER 6 HAZARDOUS WASTE FACILITY DESIGN ELEMENTS

6-1. Introduction

a. Federal regulations on hazardous waste land treatment, storage and disposal facilities (40 CFR 264) are expressed as performance standards; therefore, while required design elements are stipulated, design details are not. The EPA, however, as the agency charged with enforcement of the regulations and permitting of hazardous waste facilities, has provided specifications for the required design elements in a series of RCRA guidance documents. These documents, referenced in appendix A, contain recommendations for constructing the design features that the agency considers the minimum necessary to achieve the required performance standards. This chapter focuses on the key elements required by the regulations, including flood control systems (para 6-2), liner systems (para 6-3), leak detection and leachate collection and removal systems (para 6-4), surface water control systems (para 6-5), gas control systems (para 6-6), final cover (para 6-7), and special design features (i.e., dikes and overtopping controls and wind dispersal methods) (para 6-8). EPA specifications are generally adhered to; however, variations in design are suggested if the proposed alternative meets the performance standards set in paragraph 264, Note, however, that in cases where DA criteria are more stringent than state or federal regulations, Army standards are preeminent. Table 5-1 in chapter 5 summarizes the design elements required for each type of DA hazardous waste facility.

b. The limited scope of this design manual prevents detailed treatment of all elements of design. Reference to pertinent resource documents, noted in the text, will be necessary to provide the needed design detail.

c. Facility operations, which are treated generally in chapters 5 and 7, are discussed in this chapter only if the operational element is integrally connected with facility design and a necessary component of achieving performance standards.

6-2. Flood control systems

a. To minimize the adverse impact that washout of hazardous wastes could have on the environment, land disposal facilities must be located and designed to prevent flooding by a 100-year return frequency flood (or any greater return specified by state regulations).

(1) RCRA regulations (40 CFR 264.18(b)) require that washout be prevented, unless the owner or operator demonstrates that wastes can be removed before flooding, and that no adverse effect would result if washout were to occur. While removal of wastes is an

acceptable option, it should be avoided in favor of installing flood control features. At existing sites, an evaluation should be made of potential flood levels and the ability of design features to prevent flooding. If such features are not feasible, procedures should be developed for removal of wastes before flooding or for preventing the adverse effects of washout.

(2) Evaluation and assessment of the 100-year flood level for land disposal facilities should be based on analyses performed by the local Corps of Engineers District Office or other federal or local flood agencies, and/or on data collected at any upstream control facilities. Should such information be lacking, the need for determining the probable flood level by other means should be assessed.

(3) Earthen embankments (levees) constructed of compacted impervious soil, are commonly used to form barriers to flood waters and protect the facilities behind them. Levees may be constructed along the perimeter of disposal sites or at the base of fill along slope faces subject to inundation. To provide sufficient flood protection, levee elevations should be at least 2 feet above the 100-year flood level.

(4) Figure 6-1 presents design features of a typical levee at the perimeter of a new or uncompleted landfill. If lack of soil or available space limit levee construction, landfill slopes subject to flooding can be protected by a heavy clay structure such as that also shown in figure 6-1.

b. Additional features which may be needed for flood control structures include subsurface cutoff trenches and interior drainage structures to control seepage or run off. Furthermore, although levees are designed for long-term flood protection, proper functioning can only be ensured by periodic inspection and maintenance to guard against bank caving or sloughing, erosion and settlement of the foundation.

6-3. Liner systems

a. Introduction. Liner systems are required for all hazardous waste landfills, surface impoundments and waste piles. Liners required as part of the final cover at facility closure are discussed in paragraph 6-8. This section refers to required base liner systems. Double liners with a leak detection system are required at all DA installations unless waivers are obtained from USACE (DAEN-ECE-G), Washington, DC 20314.

(1) Specific federal regulations concerning base liner systems are summarized in table 6-1. The liner system must function for the active life of the waste unit through scheduled closure and be capable not only

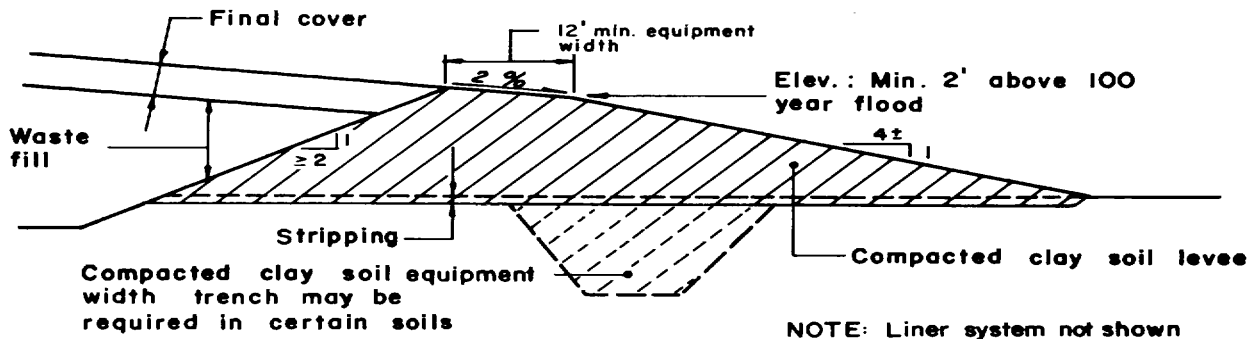

TYPICAL LEVEE AT PERIMETER OF LANDFILL

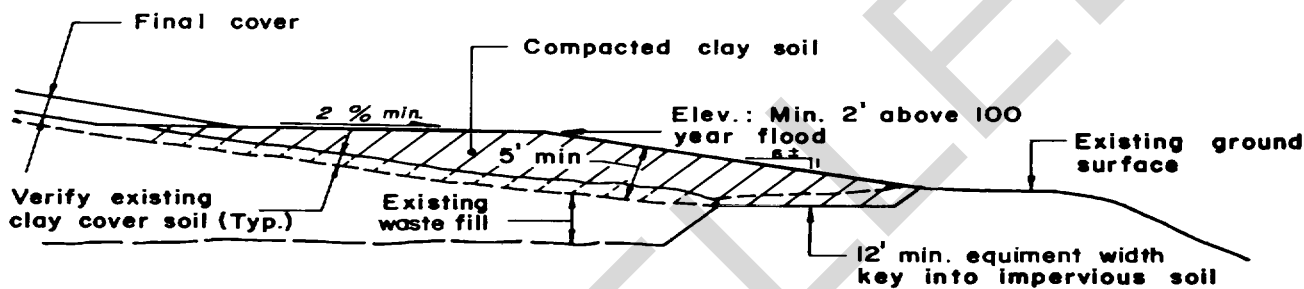

REMEDIAL FLOOD PROTECTION STRUCTURE

U. S. Army Corps of Engineers

Not to scale

Figure 6-1. Flood control structures.

of preventing migration of liquids from the facility, but also allowing no infiltration of liquids into the liner itself. The latter requirement in effect mandates use of a synthetic material as a primary liner at most hazardous waste units.

(2) Leachate collection and removal systems, capable of maintaining a leachate head no greater than 1 foot, must be installed in a drainage layer above the liners in all landfills and waste piles; leak detection systems are also required. Specific design provisions

for leachate collection and leak detection systems are discussed in paragraph 6-4.

(3) The EPA has developed design recommendations for various elements of the required liner system. Although the EPA currently considers its recommendations the minimum acceptable to ensure achievement of the performance goals set forth in the regulations, variations in system design are permitted upon successful demonstration of comparable performance.

b. Elements of the liner system. Liner systems for

Table 6-1. Requirements for Liner Systems

Section of 40 CFR 264 Describing Requirements

Design Requirements	K Surface Impoundments	L Waste Pile	M Land Treatment	N Landfill
Except for an existing portion, a unit must have a liner that is designed, constructed, and installed to prevent any migration of wastes out of the unit to the adjacent subsurface soil or ground water or surface water at any time during the active life (including the closure period).	264.221(a)	264.251(a)(1)	NA	264.301(a)(1)
Constructed of materials that have appropriate chemical properties and sufficient strength and thickness to prevent failure due to pressure gradients (including static head and external hydrogeologic forces), physical contact with the waste or leachate to which they are exposed, climatic conditions, the stress of installation, and the stress of daily operation. Installed to cover all surrounding earth likely to be in contact with the waste or leachate.	264.221(a)	264.251(a)(1)	NA	264.301(a)(1)
Placed upon a foundation or base capable of providing support to the liner and resistance to pressure gradients above and below the liner to prevent failure of the liner due to settlement, compression, or uplift.	264.221(a)	264.251(a)(1)	NA	264.301(a)(1)
Liner systems must be monitored and inspected during construction and installation, (except in the case of existing portions of units exempted from liners, as noted above).	264.221(a) 264.226(a)	264.251(a)(1) 264.254(a)	NA NA	264.301(a)(1) 264.303(a)
Cover systems (e.g., membranes, sheets, or coatings) must be inspected for uniformity, damage, and imperfections (e.g., holes, cracks, thin spots, or foreign materials) immediately after construction or installation	264.226(a)	264.254(a)	NA	264.303(a)
Soil-based and admixed liners and covers must be inspected for imperfections including lenses, cracks, channels, root holes, or other structural non-infirmities that may cause an increase in the permeability of the liner or cover	264.226(a)	264.254(a)	NA	264.303(a)

Adapted from 40 CFR 264

- For landfills, (and surface impoundments and waste piles operated for more than 30 years), regulations include an additional requirement that wastes not migrate into the liner during the active life of the site.

all facilities must be (1) constructed in unsaturated soil above the seasonal high water table, (2) placed on a foundation which will provide adequate support to the liner, and (3) installed to cover all earth likely to come into contact with waste or leachate. Required elements of the liner system depend on the type of facility and the anticipated period of time from first placement of waste to site closure.

(1) Surface impoundment liner systems depend on whether the impoundment is permitted for storage (requiring removal of all wastes, waste residues and liners at closure) or for disposal (requiring removal of free liquids, stabilization of wastes and capping at closure). The following elements are required for DA impoundments:

- Primary synthetic liner
- Secondary (clay soil or synthetic) liner
- Leak detection system
- Monitoring wells

(2) Waste piles, which can be permitted only as storage facilities, require base liner systems consisting

of a single liner of soil (clay), synthetic material, or admixed material, and a leachate collection and removal system. If closure is not scheduled for 10 years or more, a synthetic liner is to be used, and the base liner system should consist of-

- Leachate collection and removal system above primary liner
- Primary liner of synthetic material
- Secondary liner of clay soil or synthetic material
- Leak detection system between liners

(a) Alternatively, admixed materials such as concrete and asphalt may be used for long-term storage if physical and chemical analyses of their characteristics indicate they will not deteriorate during the life of the waste pile. Admixed liners are preferred for waste piles where repeated removal and replacement of wastes may occur, since synthetic membrane liners could be easily damaged by the required waste-handling equipment, and exposed areas of clay liners could dry out and crack. Reinforced concrete with appro-

appropriate coatings would be a suitable liner in such cases.

(b) Waste piles storing only dry wastes which will not generate leachate through decomposition or reaction are exempt from the provisions of this technical manual, provided they are located inside or under structures protected from infiltration of moisture.

(3) Landfill base liner systems should consist, at a minimum, of-

- Leachate collection and removal system
- Primary liner of synthetic material
- Secondary liner of clay soil or synthetic material
- Leak detection system between liners
- Monitoring wells

(4) The types of liner systems recommended for landfills, surface impoundments and waste piles are depicted in figures 6-2 and 6-3. Specific design elements necessary to ensure the performance of DA hazardous waste facilities include the following:

(a) Synthetic liners should be a minimum 30 mil in thickness when not reinforced, but a minimum 36 mil if reinforced. They must be carefully selected for compatibility with the waste and leachate to be contained.

(b) Soil liners for DA facilities should be constructed of a minimum 3-foot compacted layer of soil materials with a permeability of 1×10^{-7} cm/sec or less by EPA test methods.

(c) Soil liners should be tested for compatibility with the hazardous waste designated for disposal. A list of compatible wastes should be made available to the facility operator and made part of the permanent record. This list should also be included in facility operation manuals and related documents.

(d) Drainage layers constructed above the liners as part of leachate control or leak detection should be at least 12 inches thick, have a minimum hydraulic conductivity of 1×10^{-3} cm/sec, and be sloped at > 2 percent. Sands should be classified as either SW or SP by the USCS, with less than 5 percent passing the No. 100 sieve. In addition, sands intended to act as filters must meet filter gradation requirements, such as those shown in chapter 5 of TM 5-820-2.

c. Liner system exemptions. Retrofitting of liners is not required in already existing portions of hazardous waste units, but liners are normally required for all new portions of existing facilities, unless the owner/operator demonstrates to the EPA and USACE (DAEN-ECE-G), Washington, DC 20314, that no hazardous constituents will migrate from the facility to ground or surface waters. Migration of liquids into or out of the space between the liners is prevented by lapping and sealing the liner edges at the surface.

d. Liner types. A variety of liner materials are available for control of hazardous wastes. Table 6-2 presents their principal characteristics, advantages and

disadvantages. While soil liners are suitable for use as secondary liners and, in certain applications, as the only liner, synthetic membrane liners are considered by the EPA to be the primary mechanism for long term containment of waste and leachate from hazardous waste land treatment and disposal facilities. However, to ensure the continued effectiveness of the liners, whether soil or synthetic material, they must be compatible with the waste and leachate they are to contain and be properly installed.

e. Liner characteristics. The major categories of liners are soil liners and synthetic liners; their characteristics are summarized in table 6-2 and described in greater detail below.

(1) Soil liners may be constructed of native clay materials exhibiting a remolded permeability of 1×10^{-7} cm/sec or less and obtained on site, from selected borrow areas, or from off-site sources. The soil liner should generally fall into the CL/CH Unified Soil Classification System (USCS) with not less than 50 percent by weight passing a No. 200 sieve (US Standard), a liquid limit between 35 and 60, and a plasticity index above the "A" Line in the plasticity chart of the USCS. If available soils do not have the required low permeability, they can be blended with clay, bentonite or other additives.

(a) Soil liners have been the liner of choice at many solid waste disposal facilities (when available on site) because of their natural attenuation of many chemical substances, resistance to leachate, high cation exchange capacity, and relatively low cost. In all cases, on-site clays must be prepared for use as liners in accordance with paragraph 6-3g(1). However, because they do permit migration of leachate into the liner, the EPA considers soil liners unacceptable as the primary line of defense in preventing hazardous waste migration. Except for surface impoundments permitted for storage only and for waste piles, synthetic liners are specified for the primary liner. Soil liners are acceptable as secondary liners.

(2) Synthetic liners currently in use at hazardous waste land facilities include the following types:

- Polyvinyl chloride (PVC)
- Chlorinated polyethylene (CPE)
- High-density polyethylene (HDPE)
- Chlorosulfonated polyethylene, Hypalon (CSPE)
- Butyl rubber
- Epichlorohydrin rubber (ECO)
- Ethylene propylene terpolymer (EPT)
- Ethylene propylene rubber
- Neoprene (chloroprene rubber)
- Thermoplastic elastomers

(a) Flexible membrane linings, commonly called "plastics", include those with either polyvinyl chloride (PVC) or polyethylene (PE) bases. To produce the de-

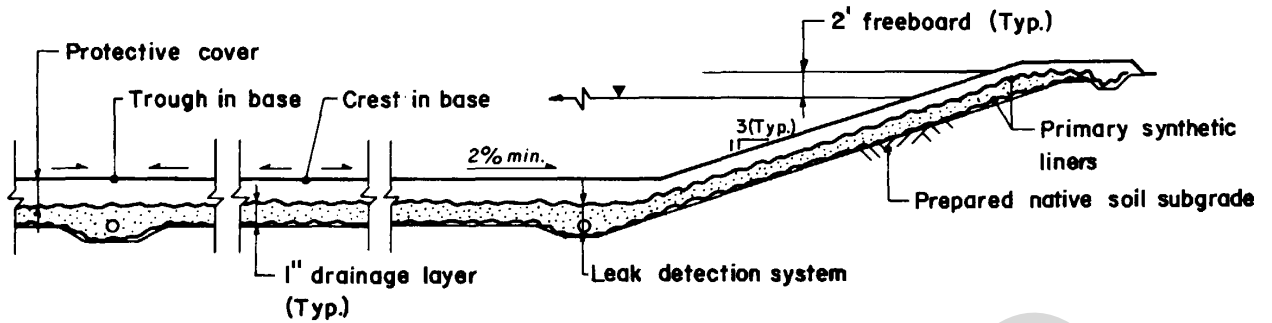

SURFACE IMPOUNDMENT UNIT

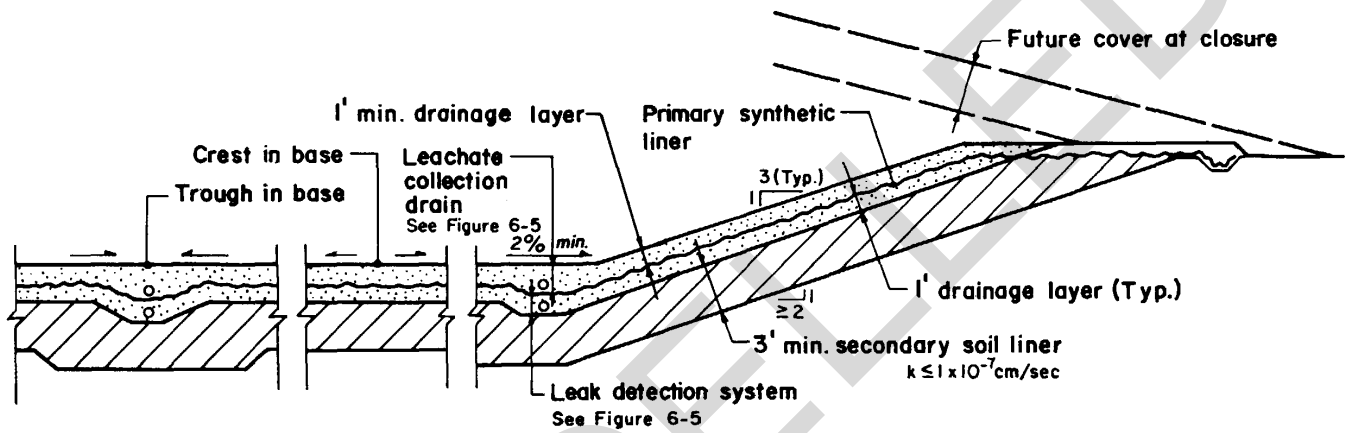

NOTE: Double liners with leak detection systems are required for surface impoundments and landfills on Army installations unless a waiver is obtained from OCE

SCALE: 1"=10'

LANDFILL UNIT

Figure 6-2. Base liner details for landfills and surface impoundments.

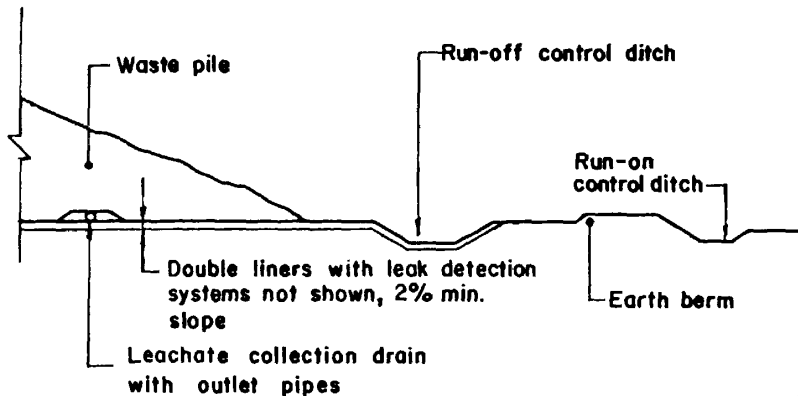

TYPICAL WASTE PILE DETAILS

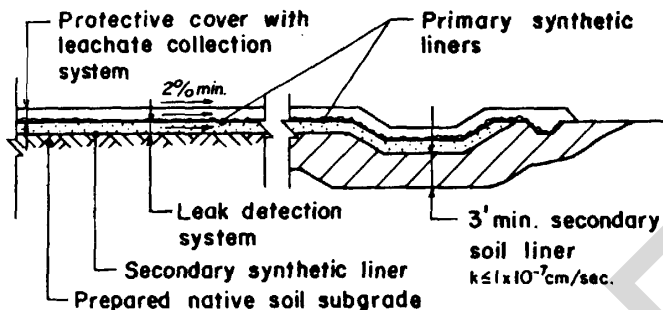

DOUBLE LINER SYSTEMS

Not to scale

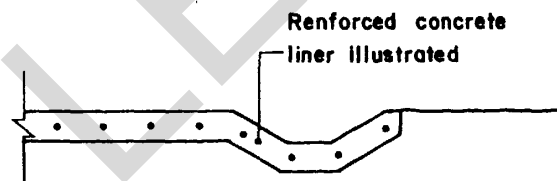

ADMIX LINER

(Where waste removal enables liner inspections)

NOTE: Double liners with leak detection systems are required for waste piles on Army installations, unless the estimated service life is 10 years or less, and wastes are periodically removed for liner inspection.

Figure 6-3. Base liner details for waste piles.

Table 6-2. Summary of Liner Types

Liner material	Characteristics	Range of costs a	Advantages	Disadvantages
<i>Soils:</i>				
Compacted clay soils	Compacted mixture of onsite soils to a permeability of 10 ⁻⁷ cm/sec	L	High cation exchange capacity; resistant to many types of leachate	Organic or inorganic acids or bases may solubilize portions of clay structure
Soil-bentonite	Compacted mixture of onsite soil, water and bentonite	L	High cation exchange capacity; resistant to many types of leachate	Organic or inorganic acids or bases may solubilize portions of clay structure
<i>Admixes:</i>				
Asphalt-concrete	Mixtures of asphalt cement and high quality mineral aggregate	M	Resistant to water and effects of weather extremes; stable on side slopes; resistant to acids, bases, and inorganic salts	Not resistant to organic solvents; partially or wholly soluble in hydrocarbons; does not have good resistance to inorganic chemicals; high gas permeability
Asphalt-membrane	Core layer of blown asphalt blended with mineral fillers and reinforcing fibers	M	Flexible enough to conform to irregularities in subgrade; resistant to acids, bases, and inorganic salts	Ages rapidly in hot climates; not resistant to organic solvents, particularly hydrocarbons
Soil asphalt	Compacted mixture of asphalt, water, and selected in-place soils	L	Resistant to acids, bases, and salts	Not resistant to organic solvents, particularly hydrocarbons
Soil cement	Compacted mixture of Portland cement, water, and selected in-place soils	L	Good weathering in wet-dry/freeze-thaw cycles; can resist moderate amount of alkalis, organics and inorganic salts	Degraded by highly acidic environments
<i>Polymeric membranes:</i>				
Butyl rubber	Copolymer of isobutylene with small amounts of isoprene	M	Low gas and water vapor permeability; thermal stability; only slightly affected by oxygenated solvents and other polar liquids	Highly swollen by hydrocarbon solvents and petroleum oils; difficult to seam and repair
Chlorinated polyethylene	Produced by chemical reaction between chlorine and high density polyethylene	M	Good tensile strength and elongation strength; resistant to many inorganics	Will swell in presence of aromatic hydrocarbons and oils
Chlorosulfonate polyethylene	Family of polymers prepared by reacting polyethylene with chlorine and sulfur dioxide	H	Good resistance to ozone, heat, acids, and alkalis	Tends to harden on aging; low tensile strength; tendency to shrink from exposure to sunlight; poor resistance to oil
Elasticized polyolefins	Blend of rubbery and crystalline polyolefins	L	Low density; highly resistant to weathering, alkalis, and acids	Difficulties with low temperatures and oils
Epichlorohydrin rubbers	Saturated high molecular weight, aliphatic polyethers with chloromethyl side chains	M	Good tensile and test strength; thermal stability; low rate of gas and vapor permeability; resistant to ozone and weathering; resistant to hydrocarbons, solvents, fuels, and oils	None reported
Ethylene propylene rubber	Family of terpolymers of ethylene, propylene, and non conjugated hydrocarbon	M	Resistant to dilute concentrations of acids, alkalis, silicates, phosphates and brine; tolerates extreme temperatures; flexible at low temperatures; excellent resistance to weather and ultraviolet exposure	Not recommended for petroleum solvents or halogenated solvents
Neoprene	Synthetic rubber based on chloroprene	H	Resistant to oils, weathering, ozone and ultraviolet radiation; resistant to puncture, abrasion, and mechanical damage	None reported
Polyethylene	Thermoplastic polymer based on ethylene	L	Superior resistance to oils, solvents, and permeation by water vapor and gases	Not recommended for exposure to weathering and ultraviolet light conditions

See footnote at end of table.

Table 6-2-Summary of Liner Types-Continued

Liner material	Characteristics	Range of costs ^a	Advantages	Disadvantages
Polyvinyl chloride	Produced in roll form in various widths and thickness; polymerization of vinyl chloridemonomer	L	Good resistance to inorganic; good tensile, elongation, puncture, and abrasion resistant properties; wide ranges of physical properties	Attacked by many organics, including hydrocarbons, solvents - and oils; not recommended for exposure to weathering and ultraviolet light conditions -
Thermoplastic elastomers	Relatively new class of polymeric materials ranging from highly polar to nonpolar	M	Excellent oil, fuel, and water resistance with high tensile strength and excellent resistance to weathering and ozone	None reported
Portland cement	Hydraulic cement of silica, lime, and alumina	H	Excellent base for waste handling equipment	Cracking

a L-\$1 to \$4 installed costs per sq yd in 1981 dollars; M-\$4 to \$8 per sq. yd.; H-\$8 to \$12 per sq. yd.

Adapted from Technologies and Management Strategies for Hazardous Waste Control, Office of Technology Assessment, Congress of the U.S1983.

sired membrane, both material resins are mixed with monomers under controlled temperature and pressure conditions in a polymerizer. Many manufacturing companies utilize these basic resins in combination with their own compounding to produce specialty membranes. A list of the producers and suppliers of raw material polymer can be found in the EPA SW-870.

(b) Specifications for individual sheet materials can be obtained from the producer. Suppliers are also able to provide specifications for the base polymers and their individual synthetic membrane sheet.

(c) To increase tensile strength, to provide resistance to shrinkage, punctures and tears and to permit easier handling and seaming, a fabric reinforcement (scrim) may be laminated between two synthetic membrane sheets. When installing reinforced liners, care must be taken to ensure that all exposed edges are sealed. Failure to do so could result in the scrim acting like a wick and drawing in moisture, resulting in eventual liner breakdown.

f. *Compatibility and physical testing.* Since the prime purpose of a liner is to prevent liquids from leaving a hazardous waste facility, the physical integrity and chemical compatibility of the liner with the waste constituents must be ensured.

(1) *Soil liners.* Permeability tests, in which soil liners are brought into contact first with water, then with leachate or chemical waste, are the most important indicators of the compatibility of soil liner materials with the waste they are to contain. Permeability is a function of many variables, including pore size, pore space tortuosity, particle shape and size, and mineralogy of the soil material, the permeant characteristics, and temperature. The permeability of a soil liner can be affected by waste types that are incompatible with the liner material. For example, clay soils may exhibit high permeability when exposed to concentrated organics, especially organics of high and low pH.

(a) To test the permeability of soil materials, samples which have been tested for their physical,

chemical and mineralogical properties may be remolded to specified moisture content and maximum dry density specified by ASTM D1557 to determine the permeability of test specimens. Test methods acceptable to EPA are contained in appendix A of the draft RCRA guidance documents for waste piles and surface impoundments. Both water and representative chemical wastes would be used for the permeant.

(b) Figure 6-4 shows the moisture content versus dry density curve for a clay liner, as well as the relationship between moisture content, relative compaction and permeability for a clay liner subjected to water and aqueous hazardous waste. All clay liners must have a permeability of 10⁻⁷ cm/sec or less.

(2) *Synthetic Liners.* Proof of the chemical resistance of the selected synthetic membrane liner is required by RCRA regulations. In recent years, all manufacturers of synthetic liners, as well as most suppliers, have operated testing facilities and developed chemical resistance tables and guides for their respective products. Reference to chemical resistance guideline sheets or compatibility charts that classify a generic flexible membrane liner will not, however, provide sufficient data on which to base a final liner selection, since the manufacturer's compounding can produce significant differences in liner properties and performance in the field. Furthermore, since the chemical characteristics of both liners and wastes are extremely variable, it is difficult to generalize concerning incompatibility. Data currently available, however, suggest that the following combinations of wastes and liner materials can be incompatible:

- * Polyvinyl chloride (PVC) tends to be dissolved by chlorinated solvents.
- * Chlorosulfonated polyethylene can be dissolved by aromatic hydrocarbons.
- * Asphaltic materials may dissolve in oily wastes.
- * Concrete- and lime-based materials are dissolved by acids.

(a) A test method accepted by the EPA for evaluating waste/liner compatibility involves exposing a liner sample to the waste or leachate encountered at the facility. After exposure, the liner sample is tested for strength (tensile, tear, and puncture) and weight loss. Any significant deterioration in the measured properties is considered evidence of incompatibility, unless it can be demonstrated that the deterioration exhibited will not impair the integrity of the liner over the life of the facility.

(b) Standard specifications for flexible membrane liners are currently being developed by the National Sanitation Foundation (NSF). Upon their final adoption, these standards will be used by the EPA to provide minimum recommendations on physical properties, construction practices and seaming. In the interim, the design engineer may review suggested standards in appendix IX of EPA SW-870.

g. Liner installation. Whether the liner to be installed is soil or synthetic material, a thorough analysis of the proposed liner foundation is necessary to ensure adequate support of the liner and resistance to pressure gradients above or below the liner. An unsuitable foundation could result in settlement, compression, or uplift of the liner which could lead to liner damage. An analysis of foundation suitability may include evaluation of geologic, hydrologic, geotechnical and other pertinent data. Such data are particularly important in the design of surface impoundments. Specific requirements for installation of soil liners and flexible membranes are discussed below.

(1) Proper installation of a soil liner is needed to maintain the specified permeability of 1×10^{-7} cm/sec or less. Prior to placement of the clay liner, the subbase must be properly prepared to ensure structural integrity and proper bonding with the clay liner. To ensure adequate compaction, soil materials should be spread in loose lifts no more than 6 inches thick, be wetted or dried to the specified moisture content of optimum or above, and be compacted with a sheepsfoot-type roller to the specified relative compaction. Specified values must be based upon the tested relationships between moisture content, relative compaction and permeability. See figure 6-4.

(a) Successive lifts should be placed and compacted until a liner thickness of 3 feet is achieved. The finished surface of the soil liner should then be rolled or bladed smooth. Installation of a clay liner should not be attempted under adverse weather conditions, such as heavy precipitation or freezing temperatures.

(b) Following installation, the liner should be inspected for imperfections, such as lenses, cracks, or other structural defects which could cause an increase in liner permeability. Until placement of waste or, in the case of a double-lined facility, the overlying synthetic liner, care must be taken to ensure that the liner

does not dry out. Controlled moisture application or coating the liner with an asphaltic emulsion may be required in some instances to prevent drying and cracking. Protection from freezing is also an important consideration in colder climates.

(2) Considerations in installation of a synthetic membrane liner include providing protective soil layers above and below the liner and proper seaming of the liner. Failure to consider these important factors could result in liner failure and undermine the goal of complete waste containment. To ensure proper membrane liner placement, seaming, and placement of protective soil cover, the best installation procedures and practices should be developed for the type of membrane proposed. Guidance in installing synthetic liners should be obtained from experienced manufacturers of the membrane, fabricators who have assisted in preparing panel installation plans and have fabricated large panels of the materials, and experienced contractors. Project specifications for the installation of the liner should state the experience required for the manufacturer, the fabricator and the installing contractor for the project.

(a) Protection of the liner involves proper preparation of the subgrade and placement of protective soil layers. Procedures to be used in preparation of the surface include compaction, scraping and rolling to provide a smooth surface for the liner. A minimum 6inch layer of material not coarser than sand (classified by USCS as SP or SW, with less than 5 percent passing the No. 100 sieve) is recommended by the EPA as a protection against puncture, equipment damage, and exposure to the elements; sands which act as filters must meet filter gradation requirements, such as those shown in chapter 5 of TM 5-820-2. Note, however, that the EPA draft guidance document for liners permits substitution of drainage layers, on-site soils or soil liners for the 6-inch sand layer.

(b) In surface impoundments, the liquid material overlying the liner is considered sufficient protection unless dredging or operation of other equipment could damage the liner. If so, an 18-inch layer of soil is recommended. Sterilization of any underlying organic materials may be necessary, particularly in the case of surface impoundments, to prevent formation of gases and subsequent uplift of the liner. In cold climates, the use of a protective soil cover may be necessary to minimize the possibility of cracking caused by freezing.

(c) Heavy geotextile fabrics (>400 g/m²) are increasingly being used in combination with flexible membrane liners in hazardous waste units to protect the membranes from puncture and abrasion. In surface impoundments, geotextiles are also used for gas relief beneath membranes (Collins and Newkirk, 1982). In addition, geotextiles may also serve as a clean base for seaming membrane panels. If geotex-

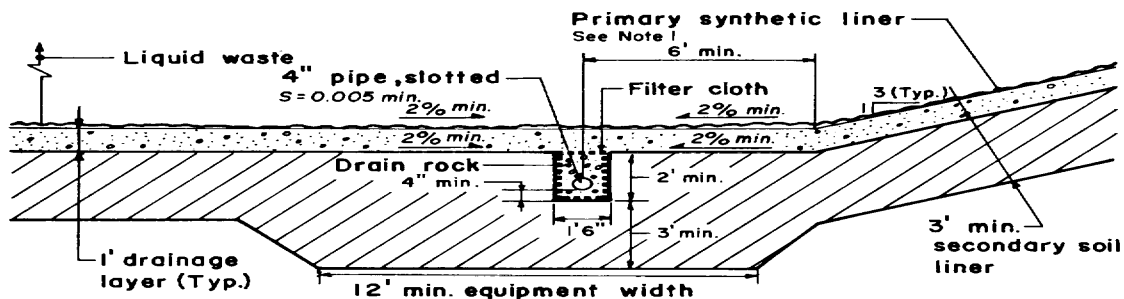

LEAK DETECTION SYSTEM FOR SURFACE IMPOUNDMENT WITH SECONDARY SOIL LINER

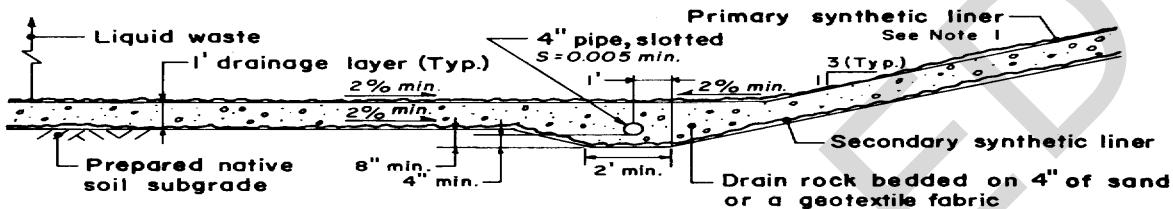

LEAK DETECTION SYSTEM FOR SURFACE IMPOUNDMENT WITH SECONDARY SYNTHETIC LINER

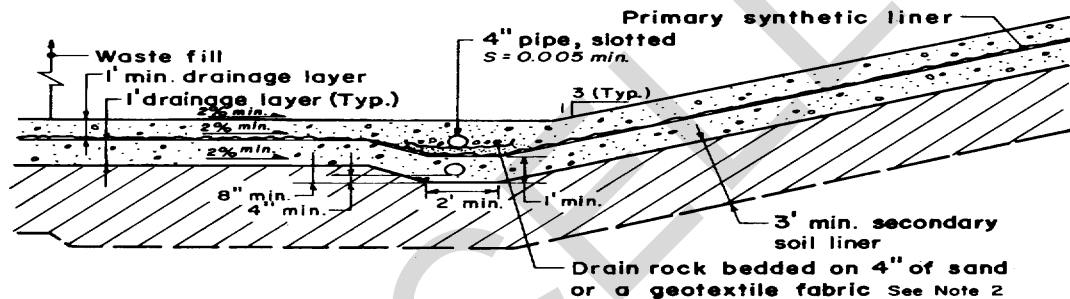

LEACHATE COLLECTION DRAIN AND LEAK DETECTION SYSTEM FOR LANDFILLS

Notes: 1. Protective cover not shown.
2. Geotextile fabrics must be evaluated for use with synthetic liners.

SCALE: 1" = 5'

Figure 6-4. Typical clay liner compatibility evaluation.

tiles are used to protect synthetic membranes, it is important that they, like the synthetic membranes, be tested for compatibility with hazardous waste. Only very limited compatibility testing data are currently available on geotextile fabrics; however, many such fabrics are made of polypropylene or polyester materials and may have compatibility characteristics similar to those exhibited by liners of the same materials.

(d) Fabricated liner panels must be constructed so as to minimize the number of field seams and to enable placement of field seams at locations where least severe field conditions occur (e.g., at ridge areas for leak detection and leachate collection systems; see figure 6-2). Project specifications should delineate liner placement procedures for field panel, shop and field seaming procedures, and protective cover requirements. Additional specifications include work responsibilities and quality assurance/certification requirements of the engineer, contractor, manufacturer, fabricator and installer. As part of the project details for the base liner system, a panel installation plan must be prepared with the grading plan.

(e) Aside from puncture and tearing of the liner, the most common cause of liner failure is inadequate seaming. The joining of liner panels should therefore be conducted under controlled conditions, in strict accordance with the manufacturer's recommendations and with installer's trained personnel. The installer should pay strict attention to the overlap specified by the manufacturer, which may range from a minimum of 2 upwards to 12 inches. In addition, field seams shall always be lapped over the downslope liner to prevent piping if a seam fails. Each type of membrane liner also requires specific seaming provisions to achieve an effective bond, as summarized in table 6-3. Since adverse weather conditions (e.g., extreme heat or cold, precipitation, and winds) can affect adequate bonding of

the liner field seams, installation should be avoided during these periods.

(f) During placement of the liner and before wastes are placed, tests of the seam strength and bonding effectiveness should be conducted, using visual inspection, air lance, ultrasonic and vacuum techniques. In addition, random samples of seams should be cut from the liner and subjected to on-site and laboratory testing. A replacement patch will be required. Liner placement, seaming and testing are covered in detail in a number of publications, including EPA SW-870.

6-4. Leak detection and leachate collection and removal systems

a. Introduction. The leak detection system, located between the two liners underlying the hazardous waste facility, enables the owner or operator to determine whether any liquid has entered the space between the liners. Should the presence of liquid in this space lead to the discovery that the liner has leaked, the owner/operator will implement procedures to ensure protection of ground water. Leachate collection and removal systems are required immediately above the liners in new hazardous waste landfills and waste piles. Such systems must be capable of maintaining a leachate depth of 1 foot or less above the liner and of withstanding clogging, chemical attack, and forces exerted by wastes, equipment or soil cover. General procedures for designing leachate collection and removal systems are provided in SW-870, paragraph 5-6 and appendix V.

b. Components of the leak detection system. The leak detection system can be a drain system or instrumentation that will permit detection of any liquid that migrates into the space between the liners. Although

Table 6-3. Seaming Provisions for Synthetic Liners'

	Type of compound a	Place used	Solvents	Bodied solvents	Solvent cements	Contact cements	Vulcanizing adhesives	Tapes	Heat sealed	Dielectric
Butyl rubber	XL	Factory	X	X
		Field	X	X
Chlorinated Polyethylene	TP	Factory	X	X	X	X	X	X
		Field	X	X	X	X	...	X	X	...
Chlorosulfonated polyethylene	TP	Factory	X	X	X	X	...	X	X	X
		Field	X	X	X	X	X	...
Elasticized polyolefin	TP	Factory	X	X	...
		Field	X	X
Ethylene propylene rubber	XL	Factory	X	X
		Field	X	X	X
Low-density polyethylene	TP	Factory	X	X	...
		Field	X	...	X	X	...
Neoprene (polychloroprene)	XL	Factory	X
		Field	X
Poly(vinyl chloride)	TP	Factory	X	X	X	X	X	X
		Field	X	X	X	X	...	X	X	...

a XL = Crosslinked or vulcanized; TP = Thermoplastic

Adapted from Liner Materials Exposed to Municipal Solid Waste Leachate (Draft), EPA Contract No. 68-03-2134, February 1982

sophisticated instrumentation is available for detection systems, direct collection in a porous medium, with removal through slotted pipes, is a simple and reliable method. Design details for such a system are similar to those for leachate collection and removal systems.

c. *Components of the leachate collection system.* Specific regulations concerning leachate systems are summarized in table 6-4. EPA guidance documents recommend that the leachate collection system consist of a drainage layer at least 1-foot-thick with a hydraulic conductivity > 1 x 10⁻³ cm/sec, and a minimum slope of 2 percent. When installed over a secondary clay liner with hydraulic conductivity of 1 x 10⁻⁷ cm/sec, such a system provides the four-order-of-magnitude difference in permeability known to significantly increase drainage efficiency.

(1) A drainage layer of clean sand, classified by USCS as SP or SW (with less than 5 percent passing the No. 100 sieve), and free of rock, fractured stone, debris, and cobbles, will also satisfy the EPA requirement for a minimum 6-inch protective layer over synthetic liners. A sand layer or filter cloth should be provided over the drainage layer if drainage rock is used to prevent infiltration of fines from the waste and subsequent clogging of the drainage layer. Sands which act as filters must meet filter gradation require-

ments, such as those shown in chapter 5 of TM 5-820-2.

(2) Nondegradable synthetic filter cloths and geotextile fabrics have also been used to replace granular materials in subdrain systems. However, the long-term performance of such materials has not been firmly established; clogging and filter cake formation can reduce the perpendicular permeability of both geotextiles and filter cloths, and overburden pressures can significantly decrease in-plane permeability of geotextile fabrics.

d. *Leachate collection pipe.* Leachate collection pipe networks should consist of slotted or perforated drain pipe bedded and backfilled with drain rock. The network should include collection pipes, installed around the base of the fill and across the base. Layouts must include base liner slopes >, 2 percent, pipe grades >0.005, and pipe spacing determined for the unit. All pipes should be joined and, where appropriate, bonded.

(1) Collection pipes must be adequately sized and spaced to minimize the leachate head on the liner system. Layouts which incorporate 4-inch-diameter pipes on 50 to 200-foot centers are considered adequate by the EPA.

(2) Procedures to evaluate and establish the spacing for collection drain pipes, based upon the anticipated maximum infiltration rate and the hydraulic

Table 6-4. Requirements for Leachate Collection and Removal Systems

Section of 40 CFR 264 Describing Requirements

Design Requirements	K Surface Impoundments	L Waste Pile	M Land Treatment	N Landfill
A leachate collection and removal system immediately above the liner that is designed, constructed, maintained, and operated to collect and remove leachate from the unit. The Regional Administrator will specify design and operating conditions in the permit to ensure that the leachate depth over the liner does not exceed 30 cm (one foot). The leachate collection and removal system must be constructed of materials that are:				
Chemically resistant to the waste managed in the unit and the leachate expected to be generated; and Of sufficient strength and thickness to prevent collapse under the pressures exerted by overlying wastes, waste cover materials, and by any equipment used at the unit; and Designed and operated to function without clogging through the scheduled closure of the unit	NA	264.251(aX2)	NA	264.301(aX2)
While in operation, leachate collection systems should be inspected weekly and after storms for the presence of leachate and proper functioning of the systems	NA	264.254(bX4)	NA	264.303(bX4)
After closure, continue to operate the no longer detected Adapted from 40 CFR 264	NA	NA	NA	264.310(bX3)

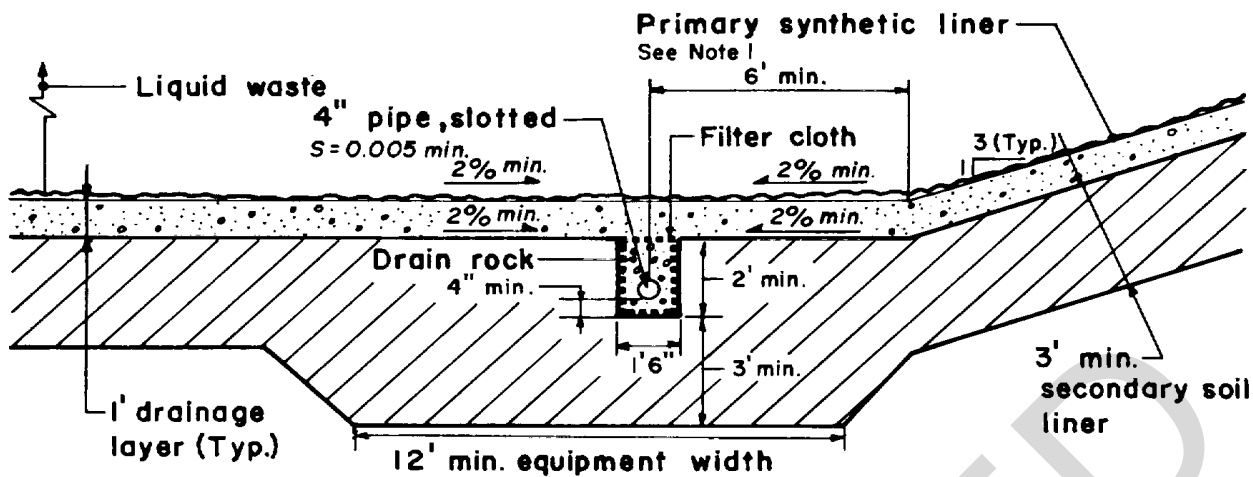

LEAK DETECTION SYSTEM FOR SURFACE IMPOUNDMENT WITH SECONDARY SOIL LINER

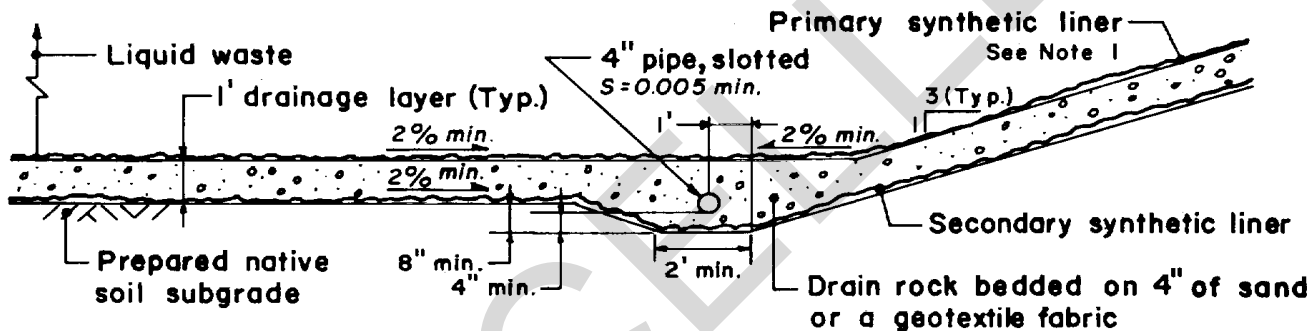

LEAK DETECTION SYSTEM FOR SURFACE IMPOUNDMENT WITH SECONDARY SYNTHETIC LINER

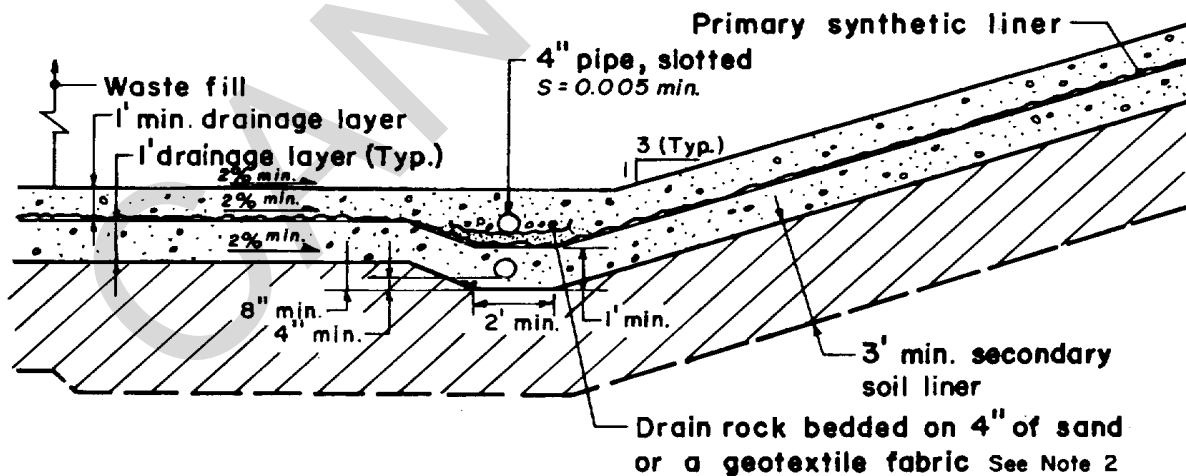

LEACHATE COLLECTION DRAIN AND LEAK DETECTION SYSTEM FOR LANDFILLS

- Notes: 1. Protective cover not shown.
2. Geotextile fabrics must be evaluated for use with synthetic liners.

SCALE : 1" = 5'

Figure 6-5. Typical leak detection systems and leachate collection drains

conductivity of the drainage layer material available, are presented in EPA SW-873, EPA SW-870 and EPA 625/1-81-013.

e. Leak detection and leachate collection drains.

As shown in figure 6-5, trench installations can be used for leak detection drains in secondary clay liners. Projecting installations should be used for synthetic liners. Slopes for bedding should be no steeper than the angle of repose of the drainage layers and all slope breaks should be rounded. Collection drains over synthetic liners should incorporate a 4-inch-minimum bedding of clean sand (SP) to satisfy requirements for liner protection. Drain rock used over synthetic liners should be rounded pea gravel. Geotextile fabrics might be evaluated to serve as an alternative protective measure.

f. Leachate collection sump and riser.

The current state-of-the-art in leachate collection system design uses sumps or basins at low points on the base of the fill to which the leachate collection network discharges. A riser pipe extending from the sump to the ground surface enables leachate removal. The lower segment of the riser pipe in the drain rock of the sump is slotted, and can be connected to a slotted header pipe in the sump to allow a higher rate of flow to, and withdrawal from, the riser pipe.

(1) The riser must be of a diameter that will accommodate a pump suction line or submersible pump. The riser pipe can be installed in a trench excavated in the wall of the clay liner, or bedded in suitable soil on the surface of the synthetic liner.

(2) Leachate collection networks for landfills, which must remain functional during the 30-year postclosure period, should include pipe cleanouts extending from major collection drains to the ground surface, to enable system inspection and/or cleaning.

g. Design considerations. In designing a leachate collection system, one must consider resistance to chemical attack, prevention of clogging, and pipe stability.

(1) All components of leachate collection systems must be able to withstand the chemical attack which can result from waste or leachate. Plastic (PVC and polyethylene) and fiberglass piping are usually selected for such systems; however, if solvents in the waste stream contain organics capable of attacking collection pipes, sumps or risers, an alternative to the use of plastic or fiberglass piping might be concrete or cast iron. Any geotextile filter cloth or fabric used in the leachate collection system shall be evaluated for its ability to withstand attack from the hazardous waste and the leachate generated from that waste.

(2) The drainage layer, any geotextile filter cloth or fabric, drain rock, pipe slotting, and waste fines must be evaluated to determine the ability of the system to transmit leachate without clogging. Although

the EPA guidance document recommends use of a granular layer above the drainage layer, if clean sand is used for the drainage layer, it will serve to preclude plugging and possibly eliminate the need for a filter cloth or fabric.

(3) The pipe used in leak detection and leachate collection systems must be of sufficient strength and thickness to withstand the pressures exerted by the weight of the overlying waste, the cover materials, and any equipment to be used on the waste unit. Slotting will reduce the effective strength of pipe and its ability to carry loads and resist pipe deflection under loading. The capacity of buried pipe to support vertical stresses may be limited by buckling and by the circumferential compressive strength of the pipe. Information on deflection, buckling capacity and compressive strength may be obtained from the pipe manufacturer.

(a) Even when correctly designed to withstand waste loading, piping can fail from equipment loading during construction or operation of the waste unit. Moving loads result in impact loading one and one-half to two times greater than stationary loading. Therefore, equipment should, if possible, not cross leachate collection drains installed in projecting installations or in trenches with shallow cover. When equipment must be routed across a drain, impact loading should be minimized by mounding material over the pipe to an adequate depth to prevent pipe failures.

(b) Specific design procedures and examples used to determine loads resulting from the waste fill and/or construction equipment are provided in appendix V.2 of SW-870.

6-5. Surface water run-on and run-off control systems

a. Regulatory requirements. Surface water run-on and run-off control systems are required for landfills, waste piles and land treatment units and indirectly for surface impoundments. Regulatory requirements for surface water control at land disposal facilities are summarized in table 6-5. While federal regulations require control systems for 24-hour, 25-year storms, state regulations may require sized control for storms with a return frequency up to 100 years. In such cases, the more stringent requirement should be considered in sizing surface water run-on and run-off control facilities. The designer must also size collection and holding facilities, and develop specific management procedures to enable all run off from active disposal areas to be retained for treatment prior to its evaporation or discharge to natural drainage courses or back to an approved hazardous waste facility.

b. Types of control systems. Run-on and run-off control systems at hazardous waste units utilize a variety of structures for control of surface water, including conveyance, barrier and control/retention systems.

Table 6-5. Requirements for Surface Water Run-on and Run-off Control Systems

Design Requirements	Section of 40 CFR 264 Describing Requirements			
	K Surface Impoundments	L Waste Pile	M Land Treatment	N Landfill
Design, construct, operate and maintain a run-on control system capable of preventing flow onto the active portion of the treatment zone during peak discharge from at least a 25-year storm.	NA	264.251(c) a	264.273(c) b	264.301(c) a
Design, construct, operate and maintain a run-off management system to collect and control (at a minimum) the water volume resulting from a 24-hour, 25-year storm	NA	264.251(d) C	264.273(d)C	264.301(d)
Design, construct, maintain and operate to prevent overtopping or overfilling by wind and wave action, rainfall and run-on	264.221(c)	NA	NA	NA
Collection and holding facilities for run-off control systems must be emptied or otherwise managed after storms to maintain design capacity of the system.	NA	264.251(e)	264.273(e)	264.301(e)
While in operation, inspect weekly and after storms to detect evidence of deterioration, malfunctions, or improper operation of run-on and run-off control systems	264.226(b)(1)d	264.254(bX1)	264.273(c)	264.303(bX1)
After closure, maintain the run-on control system and the run-off management system.	NA, unless closed as a landfill	NA, unless closed as a landfill	264.280(3),(4) 264.280(cX3),(4)	264.310(bX5)d

a The active portion.

b The treatment zone.

c Does not state that this pertains to the active portion; however, it is assumed to be such.

d This subsection of 40 CFR 264 indirectly applies.

Adapted from 40 CFR 264

(1) Typical examples of conveyance facilities, as well as erosion control measures, are provided in EPA 600/2-79-165, section 10. Examples of standard surface water control facilities, along with design procedures for their selection, design and construction, are provided in the Engineering Field Manual for Conservation Practices published by the US Department of Agriculture, Soil Conservation Service (SCS). Examples of conveyance facilities used for run-on and runoff control at hazardous waste units are shown in figures 6-6 through 6-8 and described below. These figures show grass areas with slopes of 2:1; note, however, that any vegetated final slope areas to be tractor mowed should have slopes no greater than 3:1.

2) Examples of barrier conveyance and detention/retention systems include:

- Barriers: berms, dikes
- Conveyance: swales, ditches, channels, pipe cross drains and over- side drains with inlet and outlet appurtenances; pipedrop inlets, hooded inlets, drop and chute spillway structures
- Detention/retention: sedimentation control bas-

ins and run-off retention basins

c. *Run-on control systems.* Drainage berms, ditches and overside drains or spillways can be selected and designed to prevent flow onto the active portion of waste units during peak discharges from specified return storms. Drainage swales and ditches with berms can be located to intercept and convey water run-on flows around hazardous waste sites and around waste units within the site. To reduce the potential for erosion and minimize maintenance, spillways or overside drain systems should be considered for steep ditch reaches and where collected flows must be carried down slopes for discharge.

(1) If there is any chance that overflows could damage constructed elements of waste units or enter active operation areas, they should be sized for carrying peak flows from storms with return frequencies upwards to 100 years. Erosion control measures for the conveyance system should be evaluated and selected to minimize maintenance over the anticipated service life. As described in paragraph 6-5d(2), conveyance systems developed for the waste unit perimeter to intercept run on may also be used to intercept run off from closed areas, if the surface water does not require retention.

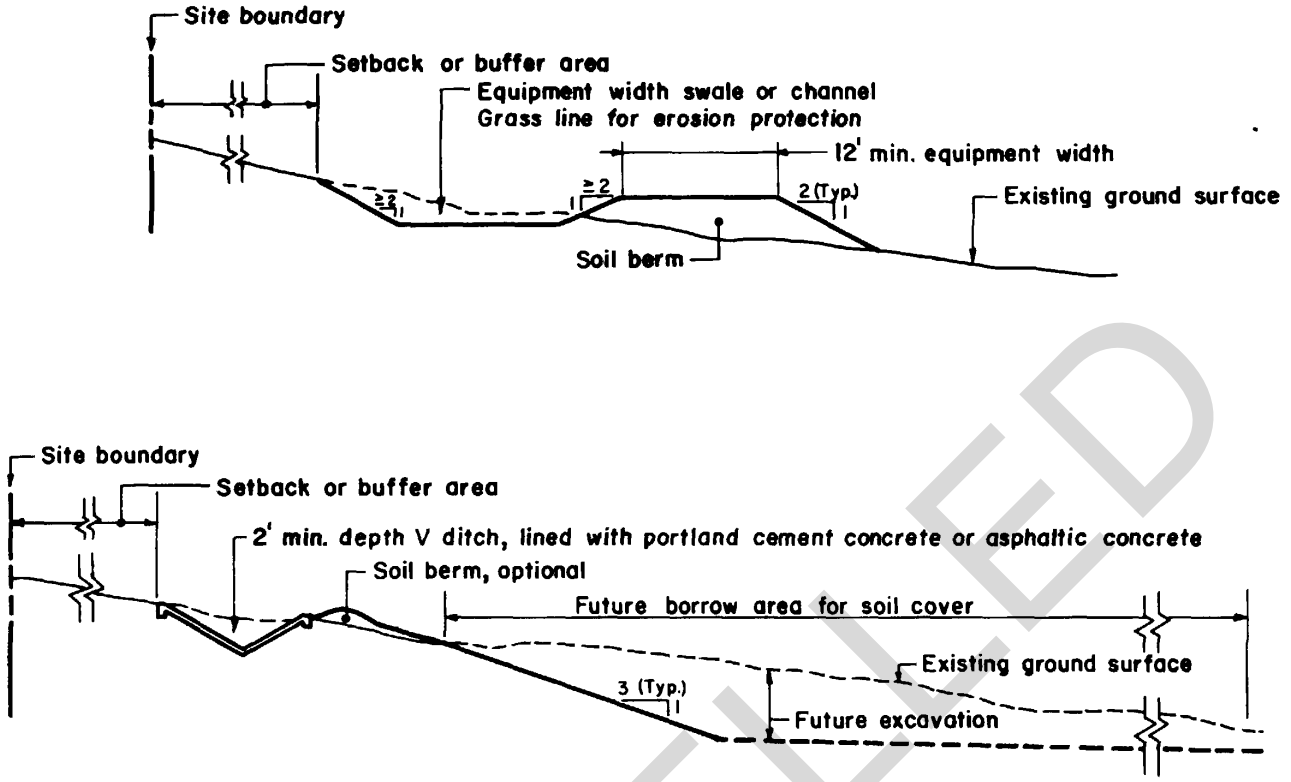

SCALE: 1" = 10'

Note: Stripping and keys for soil berms not shown.

Figure 6-6. Typical run-on control ditches.
6-16

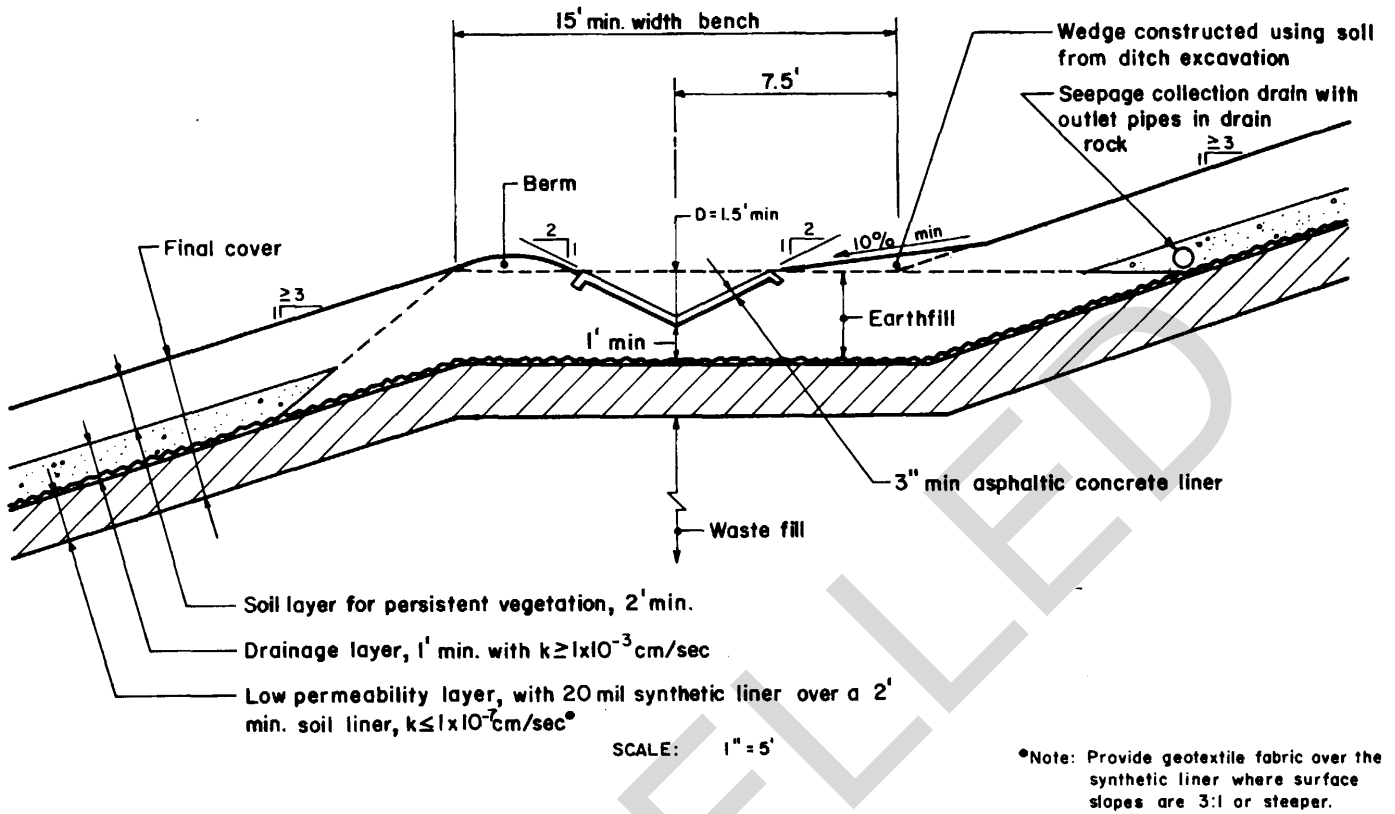

Figure 6-7. Typical run-on control ditch for waste units.
6-17

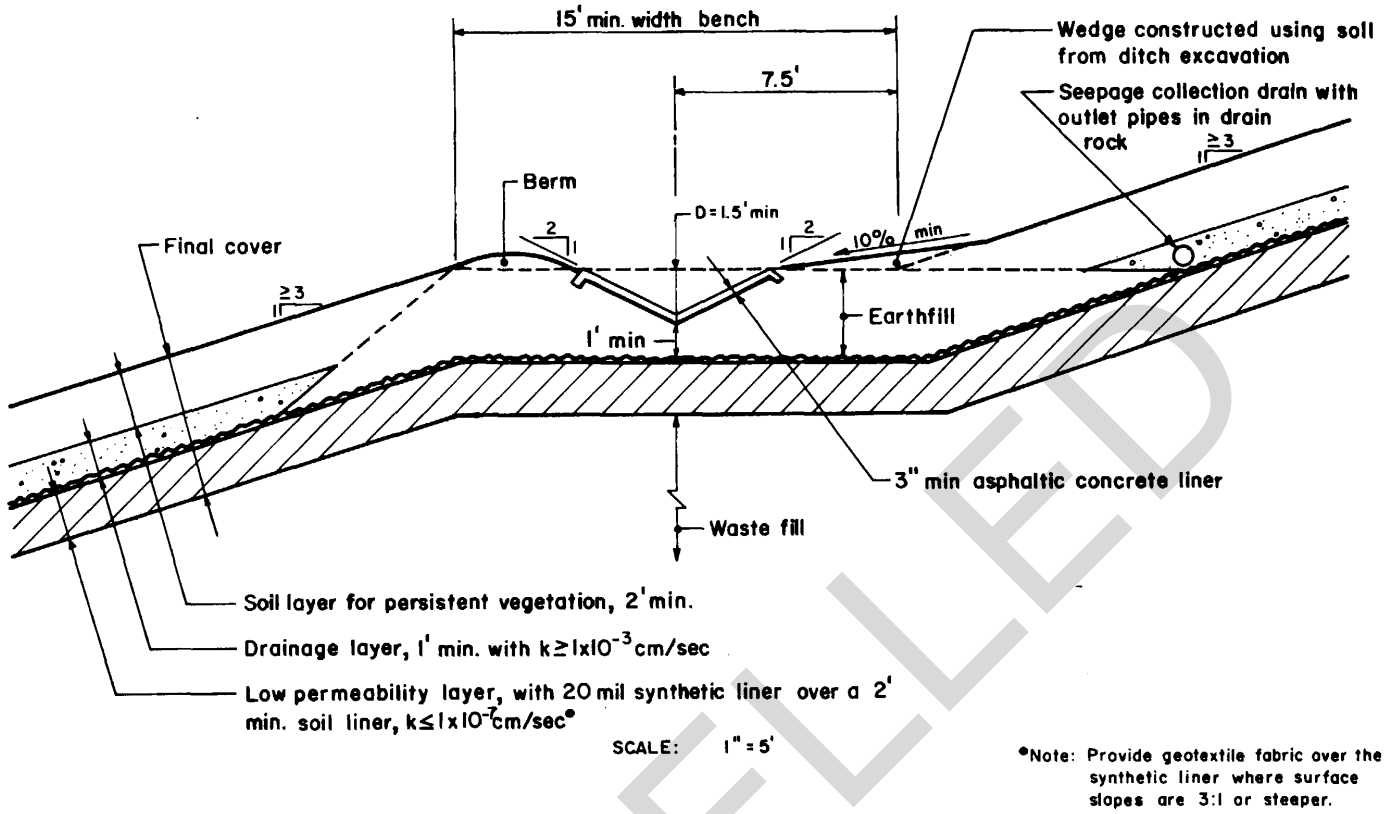

Figure 6-8. Typical run-off control ditch for final cover areas.

(2) Sedimentation controls should be established for onsite borrow areas and construction areas. Where possible, facilities for control of sediment transport should be located near the source, so that only sediment-laden waters need be handled. The near-source system requires less extensive structures than the downstream sedimentation control basin alternative for intercepted run-on flows.

(3) Sediment control facilities for source areas include:

(a) Temporary Sediment Basins-At construction areas, where run off is usually confined to ditches or depressions in the topography, basins can be constructed by excavating shallow depressions and placing berms or sandbags to contain water for sedimentation.

(b) Silt Barriers-Where sheet flow occurs (on perimeter construction slopes, and in large excavations), silt fences or hay bales placed in a shallow trench can be positioned to intercept run off and remove sediment. Silt fences normally consist of filter cloth fastened to wire fencing.

(c) Vegetation-Completed borrow areas, inactive stockpile areas, and final cover areas can be seeded, fertilized or hydroseeded to establish a vegetative cover which will provide erosion and sediment control. When vegetation has become established, downgradient silt fences or other sedimentation control structures may be removed.

(4) Sedimentation control basins (figure 6-9), used for settling out sediment being carried by surface flows, are often established at discharge locations by constructing containment dikes and excavating a basin area. To discharge surface water, emergency overflow spillways and pipe drains are typically provided.

(5) The principal maintenance requirement for sedimentation basins is removal of accumulated sediment by draglines or loaders during dry-weather periods.

d. *Run-off control systems.* Run-off control systems which handle surface water flows from active portions of hazardous waste units and any site staging areas that might contain wastes residue must include collection and holding facilities (figure 6-9). These facilities retain run off for treatment before its release, evaporation, or discharge back to an approved hazardous waste facility.

(1) For large sites located in semi-arid regions, collection and holding facilities might be developed to receive run off from the majority of the site, rather than specific waste units. Such facilities could easily be sized to retain and effect evaporation of run-off volumes much larger than those from the required 24hour, 25-year storm, ensuring full containment while minimizing operational requirements. For sites located in more humid areas, the immediate waste handling

areas and active disposal units should be confined, and operations effectively controlled, to enable collection and retention of the minimum volume of run off which may best be treated for release, or discharged back to an approved hazardous waste facility.

(2) The conveyance systems developed to carry run off from active areas of waste units, and the retention facilities developed to contain run off, must prevent any release of liquid. Closed pipes or ditches with synthetic liners should be considered for waste piles and landfills.

(3) Conveyance systems within land treatment units may include unlined terraces and grass waterways for both application of liquid waste, and for intercepting flows and minimizing erosion within the land treatment area.

(4) Retention facilities designed for all waste units should meet either storage or surface impoundment requirements. However, a lower area of either waste unit might be developed and used for the retention and treatment of run off from active areas. The adequacy of the retention basin size should be demonstrated, based upon a monthly tabulation of run-off storage requirements, and the methods for emptying the basins and dispersing of the accumulated waters, (i.e., treatment and discharge, evaporation, spray irrigation, solidification, etc.).

(5) Procedures which may be required to minimize the active area from which run off must be collected could include internal berms, synthetic cover, encapsulated wastes, and restrictions during wet-weather periods.

e. *Sizing run-on/run-off control systems.* Methods used to predict run-off volumes and peak flow rates include the Rational Formula, empirical expressions and charts of the USDA's Soil Conservation Service (SCS), and various hydrographic procedures. Both the Rational Formula and the SCS charts provide predictions which can be used in sizing surface water control systems at disposal facilities.

(eq 6-1)

- (1) For the Rational Equation: $Q = CiA$
 where: Q = flow rate (cfs)
 C = run-off coefficient (assumed)
 i = intensity of rainfall
 (inches/hour) for the selected
 design duration and frequency
 A = tributary area, in acres

(2) The value of C for sizing run-off control systems should be 0.8 to 1.0 when the active areas are barren or lined. The same factor should also be used to determine the volume of run off into holding facilities over the specified period of time. Run-off coefficients for other surface conditions applicable to land disposal facilities are available in TM 5-820-4.

(3) The SCS method provides empirically based

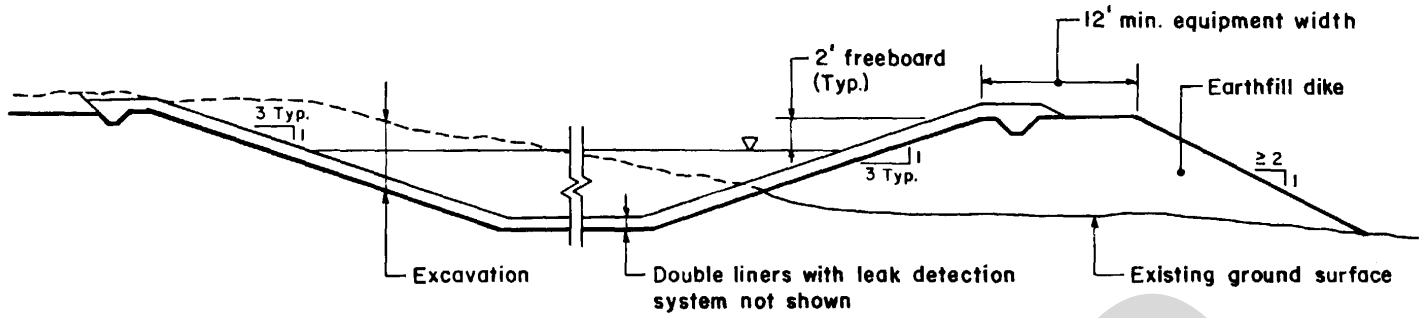

RUN-OFF RETENTION BASIN

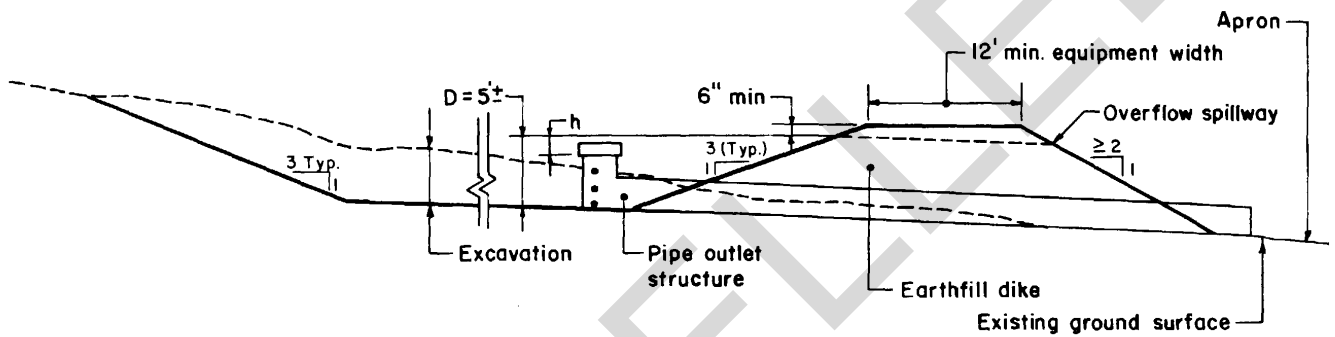

SEDIMENTATION CONTROL BASIN

SCALE: 1" = 10'

Note: Stripping and keys for earthfill dikes not shown.

Figure 6-9. Run-on sedimentation control/run-off retention basins.

charts for determining the peak rate of discharge from small watersheds, based on values for surface soil types and antecedent moisture conditions. Basic information and values are summarized in EPA 60012-79-165 and detailed in the US Department of Agriculture's engineering field manual.

(4) Sedimentation basins are sized based on analysis of settlement time for suspended solids, i.e., sands, silts and clays. Sizing procedures are provided in TM 5-820-1 through TM 5-820-4. The trapping efficiency of a basin is related to its surface area; the basin's depth only provides for sediment storage. The latter document provides an assessment of SCS sizing criteria, and demonstrates that constructing basins to control clay-sized particles during peak flows may not be practicable because the basins would need to be ten times larger than those used for control of silts.

6-6. Gas control systems

a. Introduction. Gaseous emissions from hazardous waste land disposal facilities—including landfills, surface impoundments, and land treatment sites—generally fall into two categories: (1) methane gas, produced by the anaerobic decomposition of organic wastes, and (2) toxic vapors, produced by the volatilization of chemical wastes. Methane gas, explosive in concentrations of 5 to 15 percent by volume in air, is generated mainly in landfills containing organic wastes; waste volatilization can occur at landfills, surface impoundments and land treatment sites.

(1) There are no specific regulations for control of gaseous emissions at hazardous waste facilities. In landfills containing organic wastes, compliance with the RCRA solid waste criterion for explosive gases is recommended (40 CFR section 257.3-8). This criterion stipulates that methane concentrations at the property boundary not exceed the lower explosive limit (LEL) of 5 percent; in facility structures the limit is 25 percent of the LEL, or 1.25 percent methane.

(2) EPA regulations do not specifically address the effects of hazardous waste land disposal facilities on air quality, due to the limited information on emissions from such facilities and the fact that the problem is waste-specific. However, 40 CFR 241.206-2 recommends that the need for gas control should be assessed; if the need for control measures is warranted, the location and design elements for vents, barriers or related systems should be provided on design plans for the facility. A collection system is not required at new facilities if the owner/operator can demonstrate that no gas will be produced or, if produced, would neither contribute any air pollutant to the atmosphere nor create a flammable or explosive environment.

b. Control techniques. Control techniques for volatile emissions from surface impoundments and land treatment sites are largely preventive in nature. Emis-

sions from surface impoundments can be minimized by increasing impoundment depth and decreasing surface area, and by constructing wind barriers. Removal of volatiles from the waste stream by stream stripping, distillation or incineration can also be used, where practical. In all cases, codisposal of reactive and/or incompatible wastes should be avoided. At land treatment facilities, volatilization can be mitigated by injecting volatile substances at least 6 inches below the ground surface into moist but friable soils.

(1) Venting is required at surface impoundments if gases accumulate beneath a liner and build up pressure. Sufficient gas pressure can lift the liner, creating an area where additional gas can accumulate. The higher the "gas bubble" rises, the more the membrane stretches and the less the hydrostatic pressure is able to restrain the membrane. If this condition is not controlled by venting, the liner could rupture or float to the surface of the impoundment.

(2) A number of control alternatives are available at landfills. Choice of the appropriate control system will depend on control objectives and involve determination of the type of wastes present, the depth of fill, and the subsurface characteristics of the sites and adjacent areas. In addition, field measurements should be used to determine gas concentrations, positive and negative pressure, and soil permeability.

(3) Atmospheric pipe vents, either of the "U" or mushroom configuration, can be used in landfills to control vertical movement of gases; they are most effective in areas where gases are collecting and causing pressure buildup. For example, venting is effective in preventing uplift of the top liner following closure of a landfill. Forced ventilation, on the other hand, provides an effective means of controlling both lateral and vertical migration of gases. Such systems usually employ a series of pipe vents or wells installed within lined landfills and are connected by a manifold to a motor blower. The effectiveness of vent trenches can be increased by capping the trench with clay or other impervious material and employing lateral and riser pipes connected by a manifold to a motor blower. The gas to be vented or withdrawn from the landfill may require collection and treatment to control odors and to prevent discharge of volatile toxics to the atmosphere.

c. Design considerations and constraints. Pipe vents are usually constructed of perforated PVC pipe installed in a gravel pack to prevent clogging and encourage gas migration to the vent. They should be sealed to prevent excess air from entering the system and to prevent methane or volatile toxics from leaking out. The key design considerations in installation of pipe vents, as part of either atmosphere or forced ventilation systems, are proper placement and spacing. An additional consideration for forced ventilation sys-

tems is the gas flow rate. Flow rates should be at least equal to the rate of gas production but low enough to prevent excess oxygen from being drawn into the system. Details concerning proper design of pipe vent systems are contained in Methane Generation and Recovery from Landfills, EMCON Associates (1980).

(1) Vent trenches are constructed by excavating a deep trench which is backfilled with gravel to provide a path of least resistance through which gases can migrate vertically. Design considerations in constructing vent trenches include ensuring proper ventilation by backfilling with sufficiently permeable material and avoiding infiltration of precipitation and clogging by solids. In passive closed vent trenches, ventilation can be enhanced by proper design of laterals and risers.

(2) In active vent trenches with forced ventilation, the equations and design criteria for active control wells apply, with allowances for the smaller area and greater permeability of the trench backfill. The key design consideration for vent trenches is that the depth of the trench extend to the ground-water table or an unfractured impervious stratum to prevent gas from migrating under the trench.

6-7. Final cover

a. Regulatory requirements. Final cover is required for closure of all hazardous waste landfills, surface impoundments developed for waste disposal, and those surface impoundments and waste piles at which all contaminated subsoils cannot be removed or decontaminated at closure.

(1) Specific regulations concerning final cover are summarized in table 6-6. The prime function of final cover is to minimize infiltration of precipitation. Other functions include preventing contamination of surface water run off, wind dispersion of hazardous waste, and direct contact with hazardous waste by animals or humans. To prevent liquid accumulation within closed disposal units, the regulations specify final cover must have a permeability less than or equal to the permeability of any bottom liner system or natural subsoils present.

(2) For long-term performance with minimum maintenance, the final cover must be designed to promote drainage, minimize erosion, preclude accumulation of gas pressures, and accommodate settling and subsidence.

b. Elements of the cover system. Design features and criteria recommended for final cover in the EPA guidance documents are shown in figure 6-10. The recommended three-layered final cover includes:

- * A soil layer for vegetation
- * A drainage layer
- * A low permeability layer

(1) The upper soil layer is to sustain vegetation and minimize erosion of the cover; the middle drainage layer is to carry infiltrating water from sustained precipitation to the sides of the cover for discharge; the low-permeability layer is to prevent fluid inflow and ensure that infiltrating water is carried by the drainage layer.

(2) An overview of procedures for evaluating clo-

Table 6-6. Requirements for Surface Water Run-on and Run-off Control Systems

Design Requirements	Section of 40 CFR 264 Describing Requirements			
	K Surface Impoundments	L Waste Pile	M Land Treatment	N Landfill
Cover the unit with a final cover designed and constructed to:	264.2282(iii)	May apply	NA	264.310(a)
Provide long-term minimization of the migration of liquids through the closed unit. Function with minimum maintenance Promote drainage and minimize erosion or abrasion of the final cover Accommodate settling and subsidence so that the cover's integrity is maintained; and Have a permeability less than or equal to the permeability of any bottom liner system or natural subsoils present.				
Maintain the integrity and effectiveness of the final cover, including making repairs to the cap as necessary to correct the effects of settling, subsidence, erosion, or other events.	264.228(bXI)	May apply*	NA	264.310(bXI)
Prevent run-on and run-off from eroding or otherwise damaging the final cover.	264.228(bX4)	May apply'	NA	264.310(bX5)

*If not all contaminated subsoils can be practicably removed or decontaminated, the unit must be closed in accordance with requirements that apply to landfills.

Adapted from 40 CFR 264

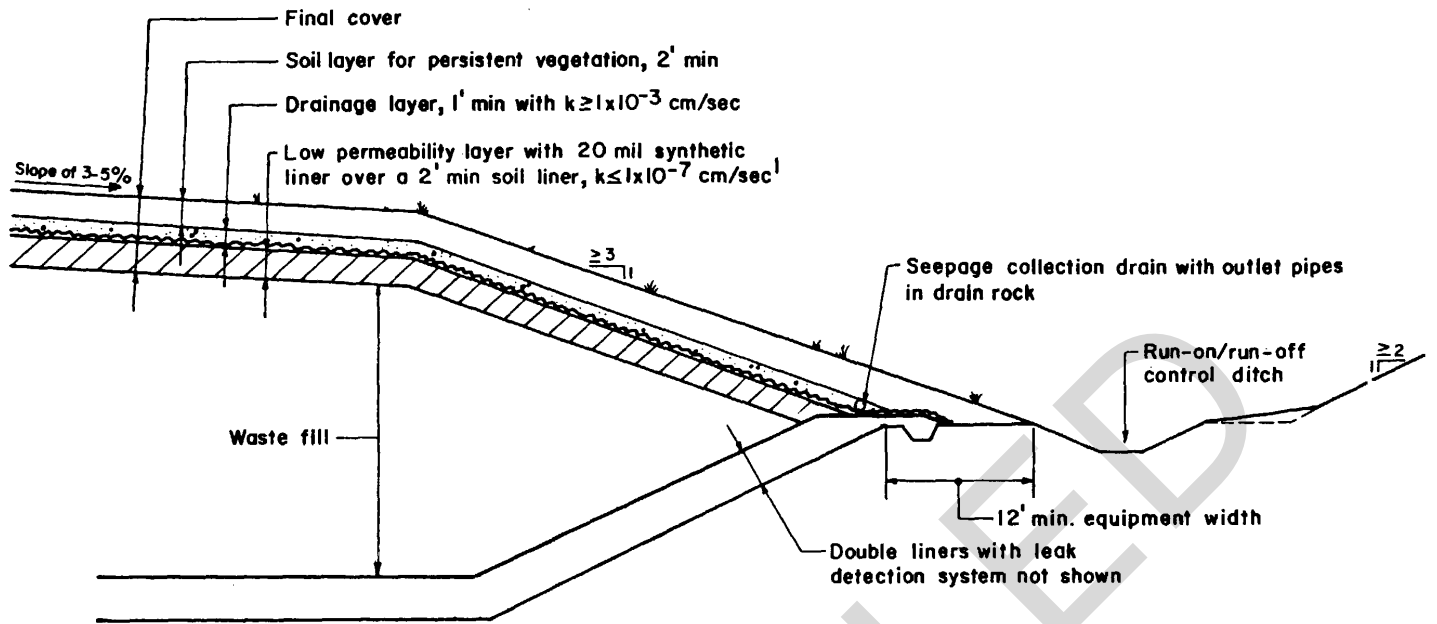

NOTES:

1. Provide geotextile fabric over the synthetic liner where surface slopes are 3:1 or steeper
2. Provide run-off control ditches for final cover areas where needed to minimize surface erosion

SCALE: 1"=10'

U.S. Army Corps of Engineers

Figure 6-10. Final cover details.
6-23

sure covers is provided in EPA SW-867. More detailed design criteria and procedures are provided in EPA 600/2-79-165 and EPA SW-873.

(3) The low permeability layer includes a minimum 2-foot-thick soil liner and a synthetic membrane at least 20 mil thick. General design, selection, and construction procedures for both synthetic and clay liners are provided in paragraph 6-2.

(a) soils suitable for the lower liner are native clay materials, or soils blended with clay, bentonite, or other additives, which can exhibit, when placed on a firm base, a recomacted permeability of 41×10^{-7} cm/sec. The soil liner should generally fall into the CL/CH Unified Soil Classification System, with not less than 50 percent by weight passing a No. 200 sieve (U.S. Standard), a liquid limit between 35 and 60, and a plasticity index above the "A" Line in the plasticity chart of the USCS. Any additive which increases the soil's vulnerability to cracking by settlement or excessive shrinkage should be avoided.

(b) Achievable field densities for cover soil liners are generally less than for base liners, because waste fill areas provide a softer, more flexible construction subgrade. The designer should obtain laboratory tests of the permeability of representative soil liner samples remolded to achievable field densities at moisture contents greater than optimum to establish construction procedures for low in-place permeability of the soil liner.

(c) The designer should specify moisture conditioning requirements, the thickness of soil layers for compaction, the type and weight of equipment, and the number of equipment passes required to achieve the required density/permeability and avoid flexural cracking during placement. The constructed soil liner shall be protected from drying until placement of the synthetic membrane. Spraying with water or application of an emulsion to prevent drying may be necessary.

(d) The EPA guidance documents specify a synthetic liner at least 20 mil thick; demonstration of the liner's compatibility with the waste or leachate is not required in this case, because the liner is not expected to be in contact with waste or leachate. Nevertheless, liner selection should be based upon its resistance to the waste present and to degradation, as well as its ability to undergo deflection due to settlement without cracking or tearing.

(e) The synthetic liner must be protected both above and below by a layer of material no coarser than sand. Sands should be classified as either SW or SP by the USCS, with less than 5 percent passing the No. 100 sieve. In addition, sands which act as filters must meet filter gradation requirements, such as those shown in chapter 5 of TM 5-820-2. The synthetic liner can be placed directly on the soil liner with ade-

quate protection, provided the upper 6 inches is no coarser than sand and free of rock, fractured stone, debris, cobbles, rubbish, and roots. A drainage layer selected to meet the requirement for bedding material can be used above the liner.

(f) Where surface slopes are 3:1 or steeper, geotextile fabrics are recommended for placement over the synthetic liner. Heavy geotextile fabrics $>, 12$ oz/yd are increasingly being used in combination with flexible membrane liners in hazardous waste units to protect the membranes from puncture and abrasion. If geotextiles are used to protect synthetic membranes, it is important that they, like the synthetic membranes, be tested for compatibility with hazardous waste. However, many such fabrics are made of polypropylene or polyester materials and may have compatibility characteristics similar to those exhibited by liners of the same materials.

(g) Care must be taken to avoid any penetration of the liner. Where inlets or outlets are required (e.g., for an impoundment), inflow/outflow piping should be designed to go over the top whenever possible. Energy dissipaters may be needed at the pipe inlet/outlets. Where penetrations cannot be avoided, precautions must be taken to ensure an adequate seal between the liner and any unavoidable penetration. In such cases, flange-type connections should be considered. EPA SW-870 outlines procedures for sealing between the liner and any penetration.

(h) EPA requires that the liner must also be protected from damage by sudden changes in slope; to prevent liners from freezing, they must be located entirely below the frost line. Procedures are provided in EPA 600/2-79-165.

(4) The drainage layer must be at least 12 inches thick, exhibit a permeability of $>1 \times 10^{-3}$ cm/sec, and be able to carry infiltrating waters to the sides of the cover for discharge.

(a) The designer should carefully evaluate the drainage layer for its ability to carry waters for discharge, and the need for a synthetic fabric filter or graded granular layer to prevent plugging due to infiltration of soils from the vegetated soil cover layer. Measures should be considered to preclude piping of the drainage layer at discharge areas.

(b) Selection of a clean sand (SP), which exhibits the required permeability and is able to carry the volume of infiltrating water, will not only satisfy the bedding requirements for the synthetic liner, but may also eliminate the need for a granular layer to prevent plugging; nevertheless, a synthetic fabric filter should be considered to ensure the long-term effectiveness of the drainage layer.

(c) Although the EPA guidance documents indicate drainage collection devices are not necessary, a perforated drainage collection pipe to intercept and

carry water from the drainage layer to surface drainage facilities may be a better alternative than granular drainage discharge areas.

(5) The soil layer for vegetation should be a high quality topsoil at least 2 feet thick, and capable of sustaining vegetation.

(a) The vegetation must be a persistent but shallow-rooted species which will minimize erosion, while not penetrating below the vegetative and drainage layers (EPA SW-867 and EPA 600/2-79-165). The vegetated soil layer must also have an erosion rate of < 2.0 tons per acre per year using the US Department of Agriculture Universal Soil Loss Equation (USLE). This equation and data for its use are described in EPA SW-867 and EPA 600/2-79-165.

(b) As noted, steeper perimeter slopes must be provided with surface drainage systems capable of conducting run off across the slope without damaging the vegetated soil cover. Stability against slippage under saturated or seismic conditions must also be demonstrated.

c. Design considerations. Because hazardous waste fills can undergo settlement, and any damaging effect of settlement on final cover must be repaired during the post-closure period, the designer should assess the potential for uniform settlement of the waste fill, recommend operating practices which minimize differential settlement, and select construction slopes which minimize the damaging effect of settlement.

(1) Settlement of waste fills generally occur due to

(a) Mechanical consolidation: a decrease in void space related to applied load(s) of the fill and soil cover and their depth.

(b) Biological decomposition: a decrease in volume by loss of solids.

(c) Displacements: differential settlements which result from liquefaction of saturated layers, creep of the waste fill, and/or collapse of drums placed prior to the ban of such practice.

(2) In new facilities, where design procedures minimize foundation settlement, and placement procedures minimize differential settlement of the fill, consolidation of the waste fill will be the primary source of settlement. The potential for settlement should be analyzed for the following conditions: compression of the foundation and compression of the waste due to dewatering, liquefaction, primary and secondary consolidation, biological oxidation of organics, * and chemical conversion of solids to liquids. EPA SW-873 provides current state-of-the-art design information to determine settlement, and additional studies are being performed for EPA.

(3) The following provisions should be considered to minimize damage by anticipated settlement:

* Calculate assuming one pound of organic matter will be destroyed for each two pounds of oxygen consumed in a BOD5 test.

(a) Selecting design slopes which will minimize the damaging effect of settlement, i.e., use 4 percent construction slopes for upper surfaces over fill areas where settlements can be expected to be uniform, due to placement procedures and a uniform depth of fill, and use 10 to 33.3 percent slopes (10:1 to 3:1 horizontal to vertical slopes) over perimeter and interim fill areas, where the depth of fill increases significantly due to the perimeter excavation, and can result in settlements which decrease the construction slope by 10 percent or more (see figure 6-10).

(b) Using uniform fill placement and solidification procedures which minimize differential settlement and enable prediction measurements for the order of settlement that can be expected after closure.

(c) Staging final closure to delay placement of final cover where substantial settlement is expected (may require an extension in the 180-day limit for closure, and placement of an expendable interim cover).

(4) Design slopes should be selected to allow for any settlement. Final slopes should be at least 3 percent to prevent ponding due to irregular surface areas, but less than 5 percent to prevent excessive erosion. Perimeter slopes may be steeper, but must be provided with surface drainage systems capable of conducting run off across the slope without forming erosion rills and gullies. Steeper slopes must be evaluated for stability against slippage under saturated or seismic conditions, and for acceptable resistance to erosion.

6-8. Special design elements

a. Regulatory requirements. Regulations within sections of 40 CFR 264 establish design, construction and maintenance requirements for structural integrity of impoundment dikes, overtopping controls, and wind dispersal controls. Requirements related to air emissions have not been established, but are expected to be developed in the future by EPA. The specific regulations are summarized in table 6-7.

b. Design considerations for dikes. Since dikes are the principal containment components of surface impoundments and are partially or completely above ground, it is essential that they be designed, constructed and maintained with sufficient structural integrity to prevent failure. Dike slopes must be stable at all times, especially during rapid drawdown of waste liquids; they must also be protected against erosion due to wave action, wind, rain or animal intrusion. Dikes must be designed so that excessive stresses are not put on the foundation.

(1) To accomplish these goals, the designers must evaluate the materials of construction, liner type(s), weather factors, loads imposed by wastes, drainage systems, and the hydrologic and geotechnical characteristics of the site. Analyzing the stability of the pro-

Table 6- 7. Requirements for Special Design Elements

Section of 40 CFR 264 Describing Requirements

Design Requirements	K Surface Impoundments	L Waste Pile	M Land Treatment	N Landfill
<i>Dikes</i>				
Dikes are designed, constructed, and maintained with sufficient structural integrity to prevent massive failure of the dikes. In ensuring structural integrity, it must not be presumed that the liner system will function without leakage during the active life of the unit.	264.221(d)	NA	NA	NA
Weekly inspection for severe erosion or other signs of deterioration in dikes.	264.226(bX4)	NA	NA	NA*
<i>Overtopping</i>				
The unit must be designed, constructed, maintained, and operated to prevent overtopping resulting from normal or abnormal operations overfilling; wind and wave action; rainfall; run- on; malfunctions of level controllers, alarms and other equipment; and human error.	264.221(c)	NA	NA	NA
Weekly inspections to detect evidence of deterioration, malfunctions, or improper operation of overtopping control systems.	264.226(bXI)	NA	NA	NA
<i>Wind Dispersal</i>				
If the unit contains any particulate matter which may be subject to wind dispersal, the owner or operator must cover or otherwise manage the unit to control wind dispersal.	NA	264.250(cX3)	264.233(f)	264.301(f)
Inspected weekly and after storms for proper functioning of wind dispersal I control systems,) where present.	NA	264.254(bX3)	264.273(gX2) 264.280(aX5)	264.303(X)(3)

* No standards or requirements established.

Adapted from 40 CPFR 264

posed or existing dike system is of primary importance; slope failure due to saturation, earthquake or poor construction could result in extensive environmental, property and human damage.

(2) Stability assessments should utilize in situ properties of the dikes and foundations and pertinent geologic information. Assessment methods and evaluative criteria are presented in NAVFAC DM 7.1 and EPA SW-873. Evaluations and monitoring must be repetitive to ensure structural integrity and containment of liquids.

c. Prevention of overtopping. Surface impoundments must be designed, constructed, maintained and operated to prevent overtopping. Designing impoundments with significant freeboard, establishing operating practices to monitor and regulate liquid levels, using automatic liquid level controllers, and/or using alarms can prevent overtopping.

(1) Specific guidance requirements to preventing overtopping include:

* For stormwater: design and operating provisions which can withstand, at a minimum, the flow generated by a 24-hour, 100-year storm.

*For flow-through units: adequately sized spillway or weir-type discharge structures which can maintain a constant liquid level and freeboard.

-pipes with valved intakes and outlets for regulating flows.

-pumping systems for control of inflows and outflows.

- For units without outlets: provisions to assess the freeboard level and regulate inflow to prevent overtopping.

(2) A 2-foot freeboard is documented as providing sufficient protection against overtopping due to inflow fluctuations or wave action; however, when manual operation is involved, greater freeboards may be necessary to ensure protection.

(3) Water balance studies must be performed for evaporation surface impoundments. The summation of liquid wastes volume and precipitation inflows, minus the evaporation losses, determines the anticipated liquid levels. The EPA believes stormwater should be diverted from surface impoundments. The guidelines to accomplish this are that structures be designed to di-

vert the maximum flow from a 100-year storm, unless the volume of the contributing flow will not cause appreciable loss of freeboard.

(4) If overtopping is imminent or a failure occurs, provisions must be available to divert flow to another unit or stop the inflow.

d. Control of wind dispersal. Wind dispersal control measures are required for waste piles, land treatment areas, and landfills. The generation and dispersion of dust from a hazardous waste unit can pose potential health hazards as well as affect visibility. Dust emissions can occur by wind erosion of exposed soil or waste areas, vehicle traffic on unpaved haul roads, and soil handling activities.

(1) Although watering for immediate control can be an effective short-term wind dispersal method, additional control methods should be implemented to minimize long-term wind erosion of open soil or waste areas. Control methods include physical, chemical or vegetative stabilization of exposed surfaces.

(2) Physical stabilization involves covering exposed surfaces with a material that prevents wind from disturbing the surface particles; materials used for this purpose include rock, soil (including daily and intermediate cover), crushed or granulated clay, bark or wood chips. Chemical stabilizers, often used in conjunction with water, can provide dust suppression for several months. Since many of these chemical compounds are proprietary, their characteristics are difficult to evaluate without site-specific field testing. Information concerning these chemical stabilizers, in-

cluding a discussion of their characteristics, is presented in EPA 600/2-79-165.

(3) A more permanent solution to controlling wind dispersal of dust is vegetating exposed inactive soil borrow areas, land application areas, and soil stockpile areas. Vegetative cover not only serves as a permanent method of suppressing dust, it also serves to enhance the aesthetics of the site. The particular vegetative species selected should be compatible with soil type, growing conditions, climate, and site end use. Additional information concerning selection of vegetative species and planting techniques is presented in EPA 600/2-79-128.

(4) Control provisions to reduce or eliminate the generation of fugitive dust from unpaved haul roads include (1) physical stabilization (placing a gravel layer on the road), or (2) chemical stabilization (application of binding materials).

(5) Imposing speed reductions on unpaved roads during dry weather can also help to reduce dust generation.

(6) For land treatment facilities, wind dispersal control measures include (1) surface wetting (irrigation) with water or chemical agents, (2) development of a vegetative cover, (3) windbreaks, and (4) waste application timing. The specific control measure(s) selected will depend on site-specific conditions. Additional information concerning wind dispersal control for land treatment units is available in EPA SW-874 and the EPA Office of Solid Waste Draft RCRA Guidance Document for Land Treatment.

CHAPTER 7 OPERATIONS AND CONTINGENCY PLANS/TRAINING

7-1. Operations

a. Purpose. The designer of hazardous waste land disposal/land treatment facilities must have an understanding of their basic operations. Such an understanding is fundamental to the development of design plans that take into account day-to-day operations, required equipment, health and safety provisions, and operator needs. A summary of general operations for landfills, surface impoundments and land treatment facilities is presented below. For a brief discussion of procedures for injection wells and waste piles, see paragraph 5-5 and 5-6, respectively.

b. Landfill operations. Typical operations at a hazardous waste landfill include the following activities:

- Unloading wastes onto the active lift by forklift or front-end loader.
- Segregating wastes in cells or subcells to prevent mixing of incompatible wastes.
- Covering wastes with soil to prevent wind dispersal.
- Grading cover soil to facilitate collecting any direct precipitation in a sump.
- Placing cover soil on areas of the landfill that have been brought to final grade.

(1) To minimize infiltration of rainfall during very wet conditions, tarps may be used to cover the active area of the landfill. In areas of very high rainfall, wastes are often containerized or stored until the rainfall season is over.

(2) Equipment for landfill operations is used for handling wastes and cover material, spill and fire control, and decontamination. Typical equipment includes:

- Forklift and front-end loader to unload and place solid waste and containers.
- Dozens and self-loading scrapers to spread and compact cover material.
- Road graders and water pickup and vacuum trucks to provide support functions such as maintenance of site roads.
- Fire control, spill control and decontamination equipment.

c. Surface impoundment operations. During the time that liquid wastes are impounded, the following inspection activities are required:

- Monitoring to ensure that liquids do not rise into the freeboard (prevention of overtopping).
- Monitoring leak detection system.
- Inspecting containment berms for signs of leakage or erosion.
- Periodic sampling of the impounded wastes for selected chemical parameters.

- Inspecting periodically for floral and faunal activities (such as animal burrows) that could cause leaks through earthen dikes, levees or embankments.

(1) Liquid wastes may be removed from an impoundment by a variety of methods, including (but not limited to) decanting, pumping and settling, solar drying, and chemical neutralization. Details concerning removal methods are presented in SW-873.

(2) Typical equipment used for closing an impoundment includes:

- Centrifugal pump or hydraulic pipeline dredge to remove impounded liquids.
- Vacuum truck to pump slurried sediment from the impoundment.
- Rotary cutter to extract hardened sediments.
- Dragline or front-end loader to excavate solidified sediments.

d. Land treatment operations. Typical land treatment operations include:

- Applying liquid wastes (less than 8 percent solids) by either spraying the waste on the land with sprinklers or by using flood or furrow irrigation techniques.
- Spreading semiliquid sludges (8 to 15 percent solids) on the land or injecting them 4 to 8 inches below the soil surface.
- Applying low-moisture solids (> 15 percent solids) to the surface and later incorporating into the soil.

(1) Regardless of which waste application method is used, the most important objectives are uniform application of wastes, and use of application rates that are tailored to the assimilative capacity of the soil.

(2) Equipment used for land treatment varies, depending on application technique selected. Typically, this includes:

- Piping and a pump to transport wastes to the point of discharge (for surface irrigation by furrow or flooding).
- Truck or trailer-mounted tank if wastes are to be applied by gravity flow or through a sprayer or manifold.
- Vacuum truck with flotation tires and rear sprayer or manifold for surface spreading of sludge.
- Moldboard plow, disk or rotary tiller for incorporating waste into the soil.
- Truck or tractor with two or more chisels if wastes are to be injected into the subsurface.

7-2. Permit application assistance

a. The design engineer should develop a detailed operations plan for the facility that will include preclosure, closure and post-closure operations. These plans are usually required as part of the state permit application process. Generally such plans describe the characteristics of the wastes handled at the facility, equipment and operating procedures, site personnel, and provisions for emergencies and other contingencies.

b. Typical components of operations plans include:

- Access Procedures
- Waste Identification
- Entry Procedures
- Waste Handling and Control
- Management and Personnel
- Operations and Safety Training
- Safety
- Facility Equipment
- Security
- Monitoring

7-3. Contingency plans

a. Section 3004(s) of the Resource Conservation and Recovery Act (RCRA) stipulates that regulatory standards for hazardous waste facilities shall include "contingency plans for effective action to minimize unanticipated damage from any treatment, storage or disposal of any such hazardous waste."

b. Subpart D (Contingency Plan and Emergency Procedures) of 40 CFR 264.50-56 outlines the required contents of the plan, personnel responsibilities and emergency procedures. Specifically, the plan must be designed to minimize hazards to human health or the environment from fires, explosions, or any unplanned sudden or non-sudden release of hazardous waste constituents to air, soil or surface water. Section 264.52(b) of subpart D states that if the owner/operator has a SPCC plan, "he need only amend that plan to comply with the requirements of this part."

c. From a facility design perspective, the contingency plan must include the facility provisions which will aid in quick and effective emergency response procedures as well as those features that will help to avoid emergency situations. These might include the following:

- (1) Primary and secondary spill containment structures and methods.
- (2) Structures and equipment used for the containment and suppression of fires (e.g., installed sprinkler or foam systems, fire breaks).
- (3) Location of facility:
 - away from active faults
 - away from sources of ignition
 - away from flood zones or low-lying coastal areas

- (4) Adequate ground-water monitoring program.
- (5) Communication and alarm systems.

d. Specific design features are not required by the contingency plan, however, an acceptable contingency plan is based on the intrinsic safety features of the individual facilities. Surface impoundments require additional contingency planning, as well as development of emergency repair procedures; similar regulations are proposed for waste piles.

7-4. Personnel requirements, training, and safety

a. Regulations promulgated under RCRA on May 19, 1980, require owners or operators of hazardous waste management facilities to train their personnel. Specifically, 40 CFR 264.16 states: "Facility personnel must successfully complete a program of classroom instruction or on-the-job training that teaches them to perform their duties in a way that ensures the facility's compliance with the requirements of this Part ..."

b. This program must be directed by a person trained in hazardous waste management procedures and must include instruction which teaches facility personnel hazardous waste management procedures (including contingency plan implementation) relevant to the positions in which they are employed. At a minimum, the training program must be designed to ensure that facility personnel are able to respond effectively to emergencies by familiarizing them with emergency procedures, emergency equipment, and emergency systems, including where applicable:

- (1) Procedures for using, inspecting, repairing, and replacing facility emergency and monitoring equipment;
- (2) Key parameters for automatic waste feed cutoff systems;
- (3) Communications or alarm systems;
- (4) Response to fires or explosions;
- (5) Response to ground-water contamination incidents; and
- (6) Shutdown of operations.

c. This training must be completed within six months from the date of employment or assignment to a facility or to a new position at a facility, whichever is later.

d. The regulations state explicitly that facility personnel must be trained and that the training must be correlated to job classification. The regulations do not provide criteria for acceptable training programs.

e. For some types of activities existent at hazardous waste management facilities, personnel training is required under the Occupational Safety and Health Act (29 CFR 1910 et seq.). However, personnel training which is required under RCRA has been interpreted as going beyond that designed to protect workers and ex-

tending into the area of community protection as well.

f. States requiring training as part of their hazardous waste regulatory program may impose training

requirements more restrictive than the RCRA requirements. As a minimum, however, all states must comply with the federal training requirements.

CANCELLED

CHAPTER 8

GROUND-WATER MONITORING

8-1. Introduction

a. Subpart F of 40 CFR 264 establishes standards for groundwater protection and monitoring that apply to owners or operators who treat, store or dispose of hazardous waste in surface impoundments, waste piles, land treatment units, or landfills.

b. Under Interim Status regulations in 40 CFR 265:F, existing surface impoundments, landfills or land treatment facilities are also required to implement ground-water monitoring programs to determine the facilities' impact on ground water.

c. If an existing facility is upgraded, the facility owner or operator must continue to comply with the interim status regulations specified in 40 CFR 265:F until final administrative action on the facility's permit application. Initial background water quality data collected during this period is used for the detection and/or compliance monitoring programs regulated by 40 CFR 264:F once a permit is granted to the facility. The designer should be aware, however, that the monitoring system installed at existing facilities in compliance with the interim status regulations may not meet the more stringent standards for permitted facilities and may require modifications or additions.

d. Many variables exist within a given hydrogeologic environment that affect ground-water occurrence. To yield usable information, as well as to ensure their effectiveness, monitoring programs must therefore be designed based on a thorough knowledge of site hydrogeology (EPA SW-963, SW-611).

8-2. Monitoring requirements

a. *Background ground-water quality.* Section 264.97 requires that ground-water quality data be collected at all hazardous waste units to establish a background value for any hazardous constituents or monitoring parameters specified in the facility permit. Sampling frequency and techniques are detailed in the regulations.

b. *Detection monitoring.* A detection monitoring program (section 264.98) is required at all hazardous waste units to provide an early indication of leakage into the uppermost aquifer.

(1) Detection monitoring, conducted at least semiannually, determines ground-water quality at the point of compliance. The parameters or constituents requiring monitoring are specified in the facility permit.

(2) The information collected is analyzed to determine whether there has been a statistically significant increase over background values for any parameter or

constituent specified in the permit. If so, the EPA Regional Administrator (RA) establishes a ground-water protection standard for the facility.

c. *Ground-water protection standard.* The groundwater protection standard indicates when corrective action is necessary to control contamination from a regulated hazardous waste unit. The standard has four main parts: (1) the hazardous constituents to be monitored (section 264.93), (2) the concentration limits for each hazardous constituent that trigger corrective action (section 264.94), (3) the point of compliance (section 264.95), and (4) the compliance period (section 264.96).

d. *Compliance monitoring.* Compliance monitoring (section 264.99) is implemented when detection monitoring reveals a confirmed, statistically significant increase in any parameter or constituent specified.

(1) Compliance monitoring requires quarterly sampling at the compliance point for hazardous constituents specified in the ground-water protection standard. Analysis for all appendix VI of 40 CFR 261 hazardous constituents must also be done annually.

(2) Data collected from these tests are analyzed to determine if a statistically significant increase in hazardous constituent concentration has occurred. If so, a corrective action program is implemented at the RA's direction.

e. *Corrective action program.* A corrective action program (section 264.100) is undertaken to ensure that hazardous waste units are brought into compliance with the ground-water protection standard. This goal must be achieved by either removing the hazardous constituents or treating them in place. Corrective action may be terminated only after ground-water monitoring data demonstrate that the standard has not been exceeded for three consecutive years.

8-3. Monitoring program

a. Determining the hydrogeologic environment of a waste disposal unit is an essential first step in designing and planning a monitoring program. The hydrogeologic investigation should include identification of the uppermost aquifer, determination of the hydraulic conductivity of underlying formations, and determination of seasonal and other fluctuations in ground-water surface elevation, which will yield information on hydraulic gradients and flow direction. Subsurface cross-sections, prepared from boring logs, geophysical surveys and existing site information, may be used in conjunction with a base map to characterize the hydrogeologic environment of the site. Methods of determin-

ing hydrogeologic conditions are detailed in chapter 3 of this manual.

b. A minimum of four ground-water monitoring wells will be installed, one hydraulically upgradient of the waste disposal unit, to provide background groundwater quality data, and three downgradient of the facility to detect contaminant discharge. Small indoor waste piles are the only waste facilities at which fewer wells will be considered.

c. Upgradient wells should be installed in the uppermost aquifer at a location not likely to be affected by the waste facility. Downgradient wells should also be installed in the uppermost aquifer, but along pathways likely to transport contaminants, should any be released from the facility. Care must be taken in locating and constructing monitoring wells to ensure that they not serve as conduits for contaminants to enter the ground water, or allow contaminated ground water to migrate to an uncontaminated aquifer.

d. Well depth should be determined on a sitespecific basis. Factors which influence well depth, as well as the depth of the sampling (or intake) interval of the well casing, include ground-water levels and the behavior of specific contaminants in the aquifer. These determinations are dependent on a detailed log of borings and on the subsurface geologic conditions. *e.* The principal components of the monitoring well are the well casing and the perforated or screened sampling interval. A typical ground-water monitoring well is shown on figure 8-1. Details on well design and sampling methods appear in SW-611 and in the RCRA guidance manual on ground-water monitoring. It must be stressed that well design must always be based on a clear and detailed understanding of site hydrogeologic conditions.

(1) One of the considerations in design of the well is selection of the proper well diameter, which depends on a number of factors, including state and federal requirements, drilling method and subsurface conditions, as well as the diameter of the sampler. Monitoring wells generally have casing diameters of either 2 or 4 inches. The larger casing size permits greater flexibility in sampling methods, since an inner diameter of 4 inches is generally required to accommodate submersible pumps and other equipment used for evacuation and sampling. Two-inch casings may be necessary or favorable in some instances, however, since they can be installed by the dry hollow-stem continuous flight auger drilling method. Some drill rigs can install 4-inch casings but such rigs are not always readily available.

(2) Proper location of the intake, or sampling, interval of the monitoring well is extremely important to ensure that it is in the path of likely contaminants and therefore likely to yield representative samples. Where aquifer zones are relatively thin (i.e., no more

than 20 feet thick), the well should be perforated throughout the zone. In thicker aquifers, multiple wells (see figure 8-2) should be used to define water quality stratification within the aquifer. Care should be taken to ensure that the perforated interval does not provide hydraulic connection between isolated aquifers.

(3) Also important is the sizing of the perforations or screen. A properly sized screen, generally one designed to exclude up to 60 percent of formation materials, will prevent passage of fines from the formation, while allowing passage of sufficient water for sampling. In most cases a commercially fabricated screen is recommended, although a factory-slotted casing may be adequate for some applications. Field perforation of well casings is not recommended.

(4) Materials selected for the well casing should be compatible with the expected contaminants to minimize the potential for interaction between the casing material and the sample. Steel casings may contribute iron and other ions to the sample. Furthermore, the metallic oxides which form on a steel casing influence concentrations of cautions and some organic molecules. PVC pipe, unlike steel well casing, is resistant to most chemicals, nonconductive, and chemically inert; however, PVC is not recommended for sampling certain reactive organic constituents such as ketones or aromatic compounds, which can better be accomplished using stainless steel or teflon. However, the final selection of well materials should be determined by a person knowledgeable about the probable chemical reactions (e.g., a chemist or chemical engineer). Needed joints in PVC casings should be fashioned using threaded couplings instead of glue to avoid contamination.

(5) Locking caps and concrete pads should be installed on all monitoring wells. Pads should be designed to divert drainage from the casing, thereby preventing precipitation or extraneous substances from entering the well.

f. Well drilling methods, filter packing, sealing and development are the components of concern in well construction, both to maintain the integrity of the borehole and to prevent contamination of samples.

(1) The drilling method selected should avoid spreading any ground-water contamination and/or interfering with the sample to be collected. Both dry and wet drilling methods are commonly used to construct monitoring wells. Conventional auger drilling is advantageous, since the potential for introducing extraneous fluids is less than with rotary drilling methods. Auger drilling is best suited to fine-grained, nonconsolidated materials; rotary (air or water) drilling is required for wells in cemented or consolidated materials such as bedrock. The maximum casing diameter in wells drilled by the standard continuous flight auger

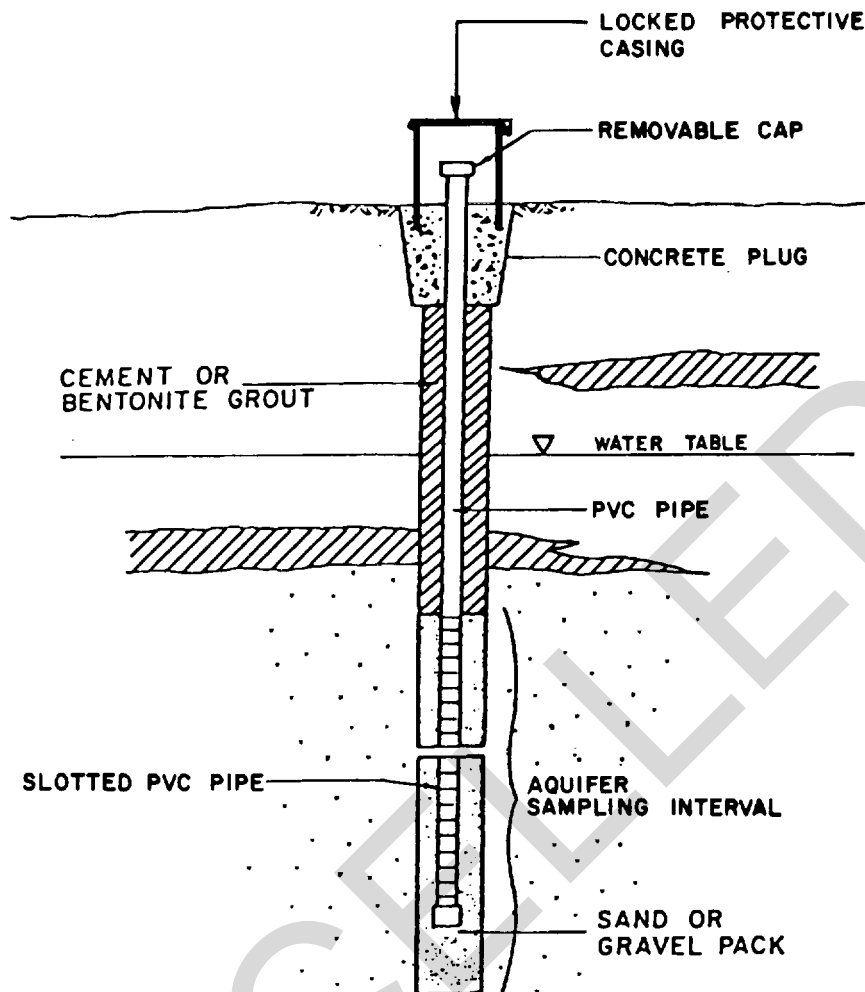

U.S. Army Corps of Engineers

Not to scale

Figure 8-1. Monitoring well details.

method is 4 inches (2 inches if inserted into hollowstem augers). However, larger non-continuous auger drilling equipment can be used in primarily finegrained deposits to install shallow wells with casing diameters up to 12 inches.

(2) If well drilling methods are employed, drilling fluids should be chosen to minimize contamination, and care should be taken to prevent entry of drilling fluids into aquifer flow zones. Generally, all additives or drilling fluids are disallowed at DA facilities except clean water and/or bentonite clay. When subsurface or contaminant conditions warrant, a variance should be requested and justification submitted to the Major Command for consideration.

(3) Filter packing is used to develop a zone of in-

creased hydraulic conductivity around the sampling interval and to prevent clogging. The filter pack consists of gravel or sand placed in the borehole around the sampling interval of the well (see figure 8-2).

Selection of the grain-size of a filter pack requires sampling and sieve analysis of the aquifer materials.

Proper installation of the filter pack is necessary to prevent separation of the fine and coarse particles and consequent bridging of the material, which could result in formation of void spaces. Use of a tremie pipe is recommended for installation of the filter pack; however in shallow wells, slow pouring or shovelling may be acceptable. For wells drilled in soil, the minimum boring diameter in the filter pack portion of the well should be at least 4 inches larger than the inner diame

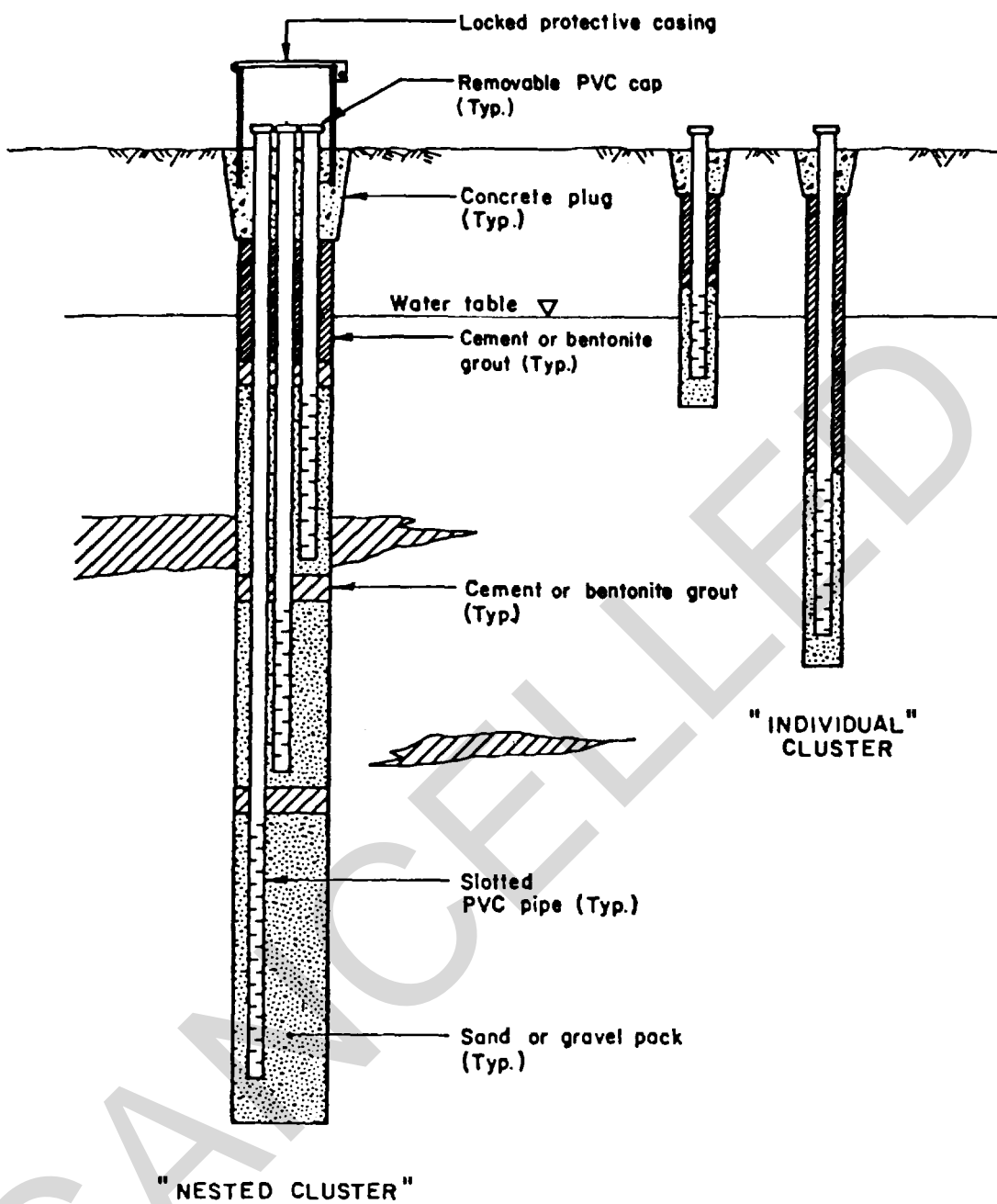

U.S. Army Corps of Engineers

Not to scale

Figure 8-2. Monitoring well installations.

ter of the screened interval; in wells drilled in rock, well diameters may be as little as 2 inches larger than the screened interval.

(4) Regulations in 40 CFR 264:F require that the annular space between the well casing and the borehole be sealed to prevent contamination of the ground water and/or sample. Both cement grout and bentonite are effective agents that are commonly used for sealing monitoring wells. If portland cement is used, special care should be taken to minimize shrinkage, as well as to prevent migration of the grout into adjacent formations. Alternatively, a grout mixture of portland cement, sand, bentonite and water can be used. If bentonite is used, a 3to 5-foot seal of bentonite pellets must be placed between the well casing and the borehole. A base of sand may also be necessary around and above the screen. Installation of sealing agents is best accomplished with a tremie pipe; pouring and tamping may, however, be adequate for shallow wells of small diameter.

(5) Well development is necessary to ensure the free flow of water into the sampling interval, to purge drilling fluids and other contaminants, and to eliminate clay, silt and other fines which could contribute to water turbidity and interfere with chemical analysis. In developing the well, ground water within the casing is repeatedly forced in and out of the sampling interval by flow reversal or surge. The well is then pumped or bailed until a volume of clear water equal to that required for operation of the sampling program is obtained. If the well cannot be adequately developed, it should be replaced with a new well.

g. Federal regulations for both existing facilities and new facilities require that a ground-water sampling and analysis plan be prepared which details procedures and techniques to be followed in collecting, preserving, shipping and analyzing samples.

(1) Water level measurements are required each time a sample is collected. Such measurements are nec-

essary to detect seasonal changes or other fluctuations in the water table which could affect flow direction and the well's ability to yield a representative sample.

(2) Before a sample is withdrawn, standing water should be purged from the well. This is an important procedure, since such water can have substantially different chemical characteristics from the ground water to be sampled, due to dissolution of gases; leaching or adsorption of casing, screen or grout materials; and/or biological activity within the well. It is generally recommended that wells be completely evacuated before sampling. High-yield wells should, if possible, be pumped dry twice and allowed to recover before sampling; one complete evacuation is sufficient for lowyield wells. If complete evacuation is not possible, a volume of water equal to 4 to 10 times the amount of standing water should be withdrawn. The exact volume to be withdrawn will depend on site-specific conditions.

(3) A variety of sampling devices are available, including bailers, portable pumps, air-lift sampler and suction pumps. Care should be taken to choose equipment that will not contaminate the sample, particularly when trace elements are to be analyzed. All equipment should be thoroughly cleaned before introduction into a monitoring well. Once a sampling device has been chosen, the same equipment and sampling procedure should be used in subsequent sampling, if values are to be compared.

(4) Accepted procedures for preserving and protecting ground-water samples during shipping and while awaiting laboratory analysis should be followed. All samples should be firmly sealed, clearly labelled and packed in compatible containers that will prevent breakage, spills and contamination. The sampling schedule and methods of analysis should be according to the regulations in 40 CFR 264:F and the guidelines presented in the RCRA ground-water monitoring guidance manual.

CHAPTER 9

CLOSURE AND POST-CLOSURE PLANS

9-1. Introduction

a. Subpart G of 40 CFR 264 establishes performance standards that must be met by individual hazardous waste treatment, storage or disposal facilities to extend protection of human health and the environment beyond the active life of the facility. These closure and post-closure standards are the basis for written plans that the facility owner or operator must prepare, amend as necessary, and submit with the permit application. Approval of the designated closure procedures and, where applicable, post-closure plans is a condition of facility operation.

b. The plan must identify the steps necessary to close or partially close the facility at any point during its intended operating life, and to completely close it at the end of its intended life. Copies of the closure and post-closure plans must be kept at the facility and revised whenever changes in the operating plans or facility design affect the closure or post-closure procedures, or whenever the anticipated year of closure changes.

9-2. Closure Procedures

a. Each hazardous waste management unit must be closed in a manner that minimizes the need for further maintenance, particularly with respect to escape of hazardous waste, leachate, contaminated rainfall or waste constituents to ground water, surface water, soil or the atmosphere. The owner or operator and a certified engineer should certify that the land disposal/land treatment facility has been closed in accordance with the approved closure plan. Closure procedures for each disposal mode are summarized below.

b. Landfill closure is achieved by installing a final cover which has a permeability less than or equal to that of the bottom liner. The cover should be capable of (1) minimizing infiltration of liquids, (2) functioning with minimum maintenance, (3) promoting drainage and minimizing erosion of cover, and (4) accommodating settling and subsidence.

c. Surface impoundments can be closed in one of two ways:

(1) Removing or decontaminating all wastes, waste residues, system components (such as liners), subsoils and structures or equipment. No post-closure care is required as long as removal or decontamination is complete.

(2) Removing liquid waste or solidifying the remaining waste. A final cover must be placed over the impoundments closed by solidification. Post-closure care of such impoundments will consist of monitoring ground water and conducting corrective action if it is

warranted (see para 8-5), and maintaining the effectiveness of the final cover. For double-lined disposal units, the leak detection system must be monitored as part of post-closure care.

d. Closure of a land treatment unit may be accomplished by either (1) establishing a permanent vegetative cover capable of maintaining growth without extensive maintenance, (2) removing and landfilling the zone of incorporation, or (3) capping the land treatment area to control wind and water erosion. General closure practices called for include minimizing run off from the treatment zone, continuing ground-water monitoring, and continuing restrictions on food-chain crops. In addition, the unsaturated zone should be monitored as part of the closure procedures; however, soil-pore liquid monitoring may be suspended 90 days after the last application of waste at the unit. Each of these practices is described in chapter 12 of EPA SW-874.

e. Closure requirements for waste piles are less stringent than those for facilities such as landfills since waste piles cannot be used for permanent disposal. The principal closure requirement for a waste pile that has achieved adequate waste containment during its active life is removal or decontamination of all waste and waste residue, and all system components (e.g., liners), subsoils, structures and equipment which have been contaminated by contact with the waste. However, if contamination of the subsoils is so extensive as to preclude complete removal or decontamination, the closure and post-closure requirements applying to landfills must be observed. Ensuring adequate containment of waste should therefore be an important consideration in initial design of a waste pile.

9-3. Components of closure plan

a. The components of the closure plan summarized below apply to all hazardous waste disposal facilities, as well as to storage facilities, i.e., those from which the wastes will be removed at closure. In addition to the general requirements, there are special provisions for the different types of hazardous waste land treatment and disposal facilities. Specific procedures to be followed in closure of hazardous waste landfills, waste piles, surface impoundments and land treatment units are contained in chapter 5.

b. At a minimum, the closure plan for all facilities must include the following elements:

(1) Procedures for partial and final closure: partial closure may involve closing part of a unit, such as a landfill cell, while other parts of the same facility continue to operate.

- (2) Estimated date(s) of partial closure.
- (3) The maximum extent of the operation that will remain open during the life of the facility.
- (4) Estimates of the maximum waste inventory in storage and in treatment at any time during the life of the facility.
- (5) Procedures to decontaminate equipment during closure.
- (6) Estimated year of final closure.
- (7) Schedule to close facility allowing 90 days after final volume of wastes is received for treatment, removal or onsite disposal. Closure must be completed within 180 days of receipt of last volume of wastes.
- (8) Procedure for updating the closure plan.

9-4. Post-closure plans

a. Post-closure plans must be prepared for all disposal facilities that will contain hazardous wastes after closure. Surface impoundments permitted for storage, i.e., those from which all wastes are to be removed at closure, must have not only a closure plan for waste removal, but also contingency closure and post-closure plans to close the unit as a landfill, should complete waste removal not be possible. Likewise, if decontamination of a waste pile cannot be completed at closure by removing the waste, waste residues, contaminated subsoils, structures and equipment, landfill closure and post-closure requirements will apply.

b. The post-closure plan for a hazardous waste disposal unit or facility describes the owner or operator's responsibilities for maintaining the environmental protection and physical security of the site for 30 years after closure. The deed of the property, or other document that would be examined during a title search, must alert any potential purchaser that the land has been used to manage hazardous wastes. The deed must notify the purchaser that post-closure use must not disturb the protective features of the site such as the liner, cap, or monitoring systems. Any variation from this standard requires approval of the

EPA administrator or authorized state department.

c. The 30-year post-closure period may be reduced if the owner or operator demonstrates that a shorter time period will be sufficient to protect human health and the environment. Conversely, the period may be extended if, for example, groundwater monitoring data indicate a potential for harmful migration of wastes.

d. The actual contents of the post-closure plan will vary with each site to reflect the degree and type of maintenance dictated by the facility life, the closure procedures, and the site's design. For most units, the post-closure plan will include activities in two principal categories: (1) ground-water monitoring, and (2) maintenance activities. Components of these plans are summarized below.

- Ground-Water Monitoring
 - Include a copy of ground-water monitoring and analysis plan
 - Indicate: (a) number, location and depth of wells to be monitored during post closure, (b) frequency of monitoring, and (c) monitoring procedures and analyses
- Maintenance Activities
 - Facility inspection schedule
 - Care of cover and/or vegetation
 - Erosion control activities
 - Maintenance of ground-water monitoring
 - Collection and disposal of leachate
 - Maintenance of gas control system
 - Care of security systems
 - Response to unplanned events such as severe storm erosion, drainage failure, drought or other occurrence that could threaten facility integrity

Within 90 days after closure is completed, a survey plat indicating the location and dimension of landfill cells or other disposal areas, must be submitted to the EPA administrator and the local zoning authority or the authority with jurisdiction over local land use.

**CHAPTER 10
COST ANALYSIS**

10-1. Cost Elements

a. Cost elements for hazardous waste facilities are based on a number of variables, including:

- Regional hydrogeologic setting
- Condition of the existing facility
- Local construction costs
- Available water quality data

Because of the number and complexity of the variables governing costs, the analysis is limited to typical hazardous waste land disposal/land treatment facilities, namely lined units.

b. Cost elements for lined hazardous waste units include materials costs for liners, underdrain systems, and ground-water monitoring wells; and installation costs, including the costs of necessary equipment and labor. Since there will be considerable variation between projects, however, a number of factors must be considered in estimating the capital cost of a lined hazardous waste unit.

(1) *Type of liner material.* Liner material costs can vary significantly, depending on the type of liner installed, the required thickness of the liner and, in the case of synthetic liners, whether they are reinforced or not. Liner type will also influence installation costs. For example, seaming methods for synthetic liners (solvent, heat or contact adhesive) may differ depending on the liner material selected; preparation of the liner base is also different for soil liners than for synthetic membranes.

(2) *Location of the facility.* The location of the hazardous waste unit can affect both the cost of labor and the delivery cost for materials. Materials costs can also be affected by the facility location, depending on the availability of needed soils and aggregates.

(3) *Facility size.* The size of the waste unit to be

lined can have a significant effect on unit costs. Polymeric membranes and natural soil materials are usually sold at a discount when purchased in large quantities.

(4) *Site conditions.* The soil types, topography and configuration of a site can influence liner installation costs. Preparation of the liner base is essential to liner effectiveness and integrity; the ease with which the base can be prepared will depend on site conditions. Whether soils for liners and earthwork must be imported (at higher cost) will also depend on site conditions.

(5) *Economic factors.* The cost of synthetic liners depends, to a large extent, on the cost of the petroleum used in their manufacture. Market supply and demand will also influence the cost of liner materials.

10-2. Unit Costs

a. Unit costs for various elements of a hazardous waste facility are presented in table 10-1.

b. The costs presented in table 10-1 are based upon standard building cost references, bid prices and telephone inquiries to material suppliers. Unit costs have, in general, been expressed in ranges to account for the variation likely to occur from site to site. In estimating the cost of a specific hazardous waste unit, the designer should consider the preliminary design criteria as well as any site-specific factors which would influence the cost of materials or installation. Contingency and wastage factors should be added to the cost of installation, to account for adverse weather, seam overlap requirements, and other such considerations; soil shrinkage and compaction should also be factored into the cost analysis.

**Table 10-1.
SUMMARY OF UNIT COSTS FOR LINED FACILITY**

Element	1983 Costs
Excavation (including clearing and grubbing)	\$1.50/yd ³
Earthfill	
berms and levees	\$2.00/yd ³
soil liners	\$3.00/yd ³
Soil Import	
sand (gradation for drainage)	\$10.00/yd ³
drainage rock (rounded) (cost delivered)	\$10.00/yd ³
Soil Placement	
sand	\$1.00/yd ³
Vegetation	
mulch and hydroseed	\$1,000/acre
Filter Cloth	\$0.75-1.50/yd ²

Table 10-1-Continued
SUMMARY OF UNIT COSTS FOR LINED FACILITY

Element	1983 Costs
Geotextile Fabrics	\$1.00-3.00/yd ²
Membrane Liners'	
Non-reinforced Materials	
30 mil PVC	0.25-0.30ft ²
30 mil CPE	0.35-0.40mft ²
30 mil Butyl/EPDM	0.45-0.50/ft ²
30 mil Neoprene	0.70-0.75/ft ²
100 mil HDPE	1.00-1.50/ft ²
Reinforced Materials	
36 mil Hypalon (CSPER)	0.50-0.55/ft ²
60 mil Hypalon (CSPER)	0.80-0.90ft ²
36 mil CPER	0.50-0.55/ft ²
Installation, excluding earthwork	0.06-0.121ft ²
2"Slotted plastic drain pipe	\$3.00/ft
Monitoring Wells	\$50.00/ft
(drilling, casing and gravel pack up to 50 feet deep)	

*Prices from Watersaver, Inc., based upon 400,000 ft² installations

U.S. Army Corps of Engineers

APPENDIX A

REFERENCES

Government Publications

Department of Agriculture, Soil Conservation Service (SCS).

National Technical Information Service, U.S. Department of Commerce, Springfield, Virginia 22161

Engineering Field Manual for Conservation Practices

Department of the Army.

AR 200-1 Environmental Protection and Enhancement

AR 200-2 Environmental Effects of Army Actions

TM 5-809-10 Seismic Design

TM 5-818-1 Foundation Design of Buildings

TM 5-820-1 Surface Drainage Facilities for Air Fields and Heliports

TM 5-820-2 Subsurface Drainage Facilities for Air Fields

TM 5-820-3 Drainage and Erosion Control for Air Fields and Heliports

TM 5-820-4 Drainage for Areas Other Than Air Fields

Department of the Interior, Bureau of Reclamation.

Superintendent of Documents, Government Printing Office, Washington D.C. 20402

Design of Small Dams, 1973.

Environmental Protection Agency (EPA).

National Technical Information Service, U.S. Department of Commerce, Springfield, Virginia 22161.

600/2-79-128, August 1979. Adapting Woody Species and Planting Techniques for Landfill Conditions.

600/2-79-165, August 1979. Design and Construction of Covers for Solid Waste Landfills.

SW-611, 1980. Procedures Manual for Ground-Water Monitoring of Solid Waste Disposal Facilities.

SW-846, 1982. Test Methods for Evaluating Solid Waste.

SW-867, Lutton, R. J., 1982. Evaluating Cover Systems for Solid and Hazardous Waste.

SW-870, Matrecon, Inc., 1983. Lining of Waste Impoundment and Disposal Facilities.

SW-873, Acurex Corporation and Metcalf & Eddy, Inc., 1982. Closure of Hazardous Waste Surface Impoundments.

SW-874, K. W. Brown & Associates, 1983. Hazardous Waste Land Treatment.

SW-963, 1980. Ground-Water Monitoring Guidance for Owners and Operators of Interim Status Facilities.

Office of Solid Waste, 1983. RCRA Guidance Document for Land Treatment (Draft).

625/1-81-013, 1981. Process Design Manual-Land Treatment of Municipal Wastewater.

General Services Administration.

Superintendent of Documents, Government Printing Office, Washington, D.C. 20402

Code of Federal Regulations, Title 40, Part 146

Code of Federal Regulations, Title 40, Part 260

Code of Federal Regulations, Title 40, Part 261

Code of Federal Regulations, Title 40, Part 262

Code of Federal Regulations, Title 40, Part 264

Code of Federal Regulations, Title 40, Part 265

Code of Federal Regulations, Title 40, Part 270

Naval Facilities Engineering Command (NA VFAC).

Superintendent of Documents, Government Printing Office, Washington D.C. 20402

DM 7.1 Soil Mechanics

U.S. Congress.

Superintendent of Documents, Government Printing Office, Washington D.C. 20402

Clean Air Act, PL 95-396, 42 USC 7401 et seq.

Clean Water Act, PL 95-217, 33 USC 1251 et seq.

Federal Insecticide, Fungicide, and Rodenticide Act, PL 94-140, 7 USC 136 et seq.

Marine Protection Research and Sanctuaries Act of 1972, PL 92-532, 33 USC 1401 et seq.

National Environmental Policy Act (NEPA), PL 91-190, 42 USC 4321 et seq.

Occupational Safety and Health Act, PL 91-596, 29 CFR 1910 et seq.

Resource Conservation and Recovery Act (RCRA), PL 94-580, 42 USC 6901 et seq.

Safe Drinking Water Act, PL 93-523, 42 USC 300f et seq.

Toxic Substances Control Act, PL 94-469, 15 USC 2601, et seq.

U.S. Congress, Office of Technology Assessment, March 1983. Technologies and Management Strategies for Hazardous Waste Control.

Nongovernment Publications

American Society for Testing and Materials, 1916 Race Street, Philadelphia, PA 19103

ASTM Method Test for Moisture-Density Relations of Soils and Soil-Aggregate Mixtures Using 10-lb (4.54-kg) Rammer and 18-in (457-mm) Drop

APPENDIX B

B-1. Purpose and scope

The tables presented in this appendix are intended to illustrate the regulatory requirements applicable to the design of land disposal/land treatment facilities

B-2. Tables

Table B-1 Summary of RCRA Hazardous Waste Regulations Applicable to TM 5-814-7.

Table B-2. Review of State Hazardous Waste Management Programs.

Table B-1. Summary of RCRA Hazardous Waste Regulations Applicable to TM 5-814- 7'

Regulation	Title	Applicable Elements of the Regulation
40 CFR 260	Hazardous Waste Management System: General	<ul style="list-style-type: none"> • Definitions • Petitions for equivalent testing • Petitions to exclude a waste generated at a particular facility
40 CFR 261	Identification and Listing of Hazardous Waste	<ul style="list-style-type: none"> • Defines hazardous waste and those wastes which are excluded under the broad definition • Recycled or recovered waste exclusion • General hazardous waste characteristics • Lists of hazardous waste
40 CFR 262	Standards Applicable to Generators of Hazardous Waste	<ul style="list-style-type: none"> • Hazardous waste determination • Recordkeeping and reporting requirements • Procedures for notification of hazardous waste activity
40 CFR 264 Subpart A	Standards for Owners/Operators of Hazardous Waste Treatment, Storage and Disposal Units	<ul style="list-style-type: none"> • Scope and applicability of the standards • Enforcement in cases of "imminent Hazard" • Relationship of these standards to the permitting process
Subpart B	General Facility Standards	<ul style="list-style-type: none"> • Waste analysis requirements • Security • Inspections • Personnel training • Requirements for ignitable, reactive or incompatible waste
Subpart C	Preparedness and Prevention	<ul style="list-style-type: none"> • General design and operation criteria to prevent unplanned sudden or non-sudden releases of hazardous wastes
Subpart D	Contingency Plan and Emergency Procedures	<ul style="list-style-type: none"> • Contents of the contingency plan • Emergency procedures for responding to fires, explosions or material release • Definition of personnel responsibilities
Subpart E	Manifest System, Record-keeping and Reporting	<ul style="list-style-type: none"> • Use of manifest system • Reporting requirements
Subpart F	Ground-Water Protection	<ul style="list-style-type: none"> • Procedures to identify escape of contaminants from facilities • General ground-water monitoring requirements • Protection standards and allowable concentration limits for permit obtainment • Detection monitoring program • Compliance monitoring program • Corrective action program
Subpart G	Closure and Post Closure	<ul style="list-style-type: none"> • Establishes closure performance standards • Post-closure care and property use
Subpart K	Surface Impoundments	<ul style="list-style-type: none"> • Prevention of overtopping • Liner design and materials (DA impoundments are required to have double liners and leak detection or secondary leachate collection systems for non-inspectable installations) • Ground-water monitoring requirements • Run-on/run-off controls • Cap requirements • Closure requirements
Subpart L	Waste Piles	<ul style="list-style-type: none"> • Liner design and materials (DA waste piles are required to have double liners and leak detection or secondary leachate collection systems for non-inspectable installations) • Leachate collection and removal systems • Ground-water monitoring requirements • Monitoring exemptions

* The regulations summarized in this table represent technical and performance standards for hazardous waste units; omitted from the table is 40 CFR 270, which presents the procedural requirements and criteria for the part B permit process.

Table B-1. Summary of RCRA Hazardous Waste Regulations Applicable to TM5-814- 7 (Continued)

Regulation	Title	Applicable Elements of the Regulation
Subpart M	Land Treatment	<ul style="list-style-type: none"> • Run-on/run-off controls • Special waste controls • Closure/post-closure care • Treatment program performance standards based on treatment zone and waste constituents • Site selection criteria • Soil preparation and care • Run-on/run-off controls and treatment • Wind dispersal controls • Vegetation • Unsaturated zone monitoring requirements <ul style="list-style-type: none"> -soil-pore liquid tests -chemical make up of soil
Subpart N	Landfills	<ul style="list-style-type: none"> • Closure/postclosure care • Design and operating requirements: liners, leachate collection systems, exemption demonstration, run-on or run-off control systems, wind dispersal control • DA landfills are required to have double liners and leak detection or secondary leachate collection systems • Exemption from Subpart F for double-lined units • Monitoring program <ul style="list-style-type: none"> -detection -compliance -correction • Inspections • Special requirements for liquid wastes • Special requirements for containerized waste • Closure/post-closure requirements

US Army Corps of Engineers.

Table B-2. Review of State Hazardous Waste Management Programs

State	Universe of Waste ¹	Specific Siting Procedures ²	Burial Restriction	Policies Discourage Landfilling
Alabama	RCRA		X	
Alaska	RCRA			
Arizona	Equivalent + expanded criteria	X		X
Arkansas	RCRA + PCB's			
California	RCRA + expanded criteria	X		X
Colorado	Equivalent		X	
Connecticut	RCRA by statute	X		X
Delaware	RCRA			
Florida	RCRA by reference	X		X
Georgia	RCRA by reference	X		X
Hawaii	RCRA			
Idaho	RCRA			
Illinois	RCRA + special wastes	X	X	X
Indiana	RCRA	X		X
Iowa	RCRA by reference	X		X
Kansas	RCRA	X		X
Kentucky	RCRA by reference	X		X
Louisiana	RCRA + expanded waste list			
Maine	RCRA	X		X
Maryland	RCRA + PCB's	X	X	X
Massachusetts	RCRA + PCB's, oil, radioactive wastes	X		X
Michigan	RCRA + oil, other toxic wastes	X		X
Minnesota	RCRA + oil	X		X
Mississippi	Equivalent		X	
Missouri	RCRA	X		X
Montana	RCRA			
Nebraska	RCRA by reference	X		

Table B-2. Review of State Hazardous Waste Management Programs (Continued)

State	Specific Siting Universe of Waste ¹	Burial Procedures ²	Policies Discourage Restriction	Landfilling
Nevada	RCRA			
New Hampshire	RCRA	X		X
New Jersey	RCRA + PCB's, oil	X		X
New Mexico	RCRA			
New York	RCRA by statute	X		X
North Carolina	RCRA	X		X
North Dakota	RCRA		X	
Ohio	RCRA	X		X
Oklahoma	RCRA: no recycling exemption		X	
Oregon	Equivalent: no waste listing	X		X
Pennsylvania	Equivalent		X	
Rhode Island	Equivalent: limited listing	X		X
South Carolina	RCRA: no recycling exemption		X	
South Dakota	RCRA			
Tennessee	Equivalent	X		X
Texas	RCRA + halogenated hydrocarbons			
Utah	RCRA		X	
Vermont	Equivalent			
Virginia	RCRA			
Washington	RCRA + expanded waste list	X		
West Virginia	RCRA			X
Wisconsin	RCRA			X
Wyoming	RCRA			

NOTES:

1. Universe of Waste: refers to the list of regulated wastes in that state.
 RCRA-State program is nearly identical to Federal regulations.
 Equivalent-State program is equivalent, but not identical to Federal regulations.
 RCRA by reference-State program adopted Federal regulations by reference.
2. Specific Siting Procedures: refers to measure taken by the individual states to ensure new facilities are sited in a manner and location that is acceptable (or tolerable) to local citizenry.
 Adapted from Technologies and Management Strategies for Hazardous Waste Control, Office of Technology Assessment, Congress of the US, 1983.

APPENDIX C

EXAMPLE DESIGN PROBLEM

C-1. Purpose and Scope

The design example in this appendix illustrates pre-design considerations and design principles that relate to the development of plans for a hazardous waste landfill and surface impoundment. Both facilities are assumed to be developed for an existing government owned, contractor-operated, industrial installation that manufactures small arms, ammunition and chemical materials. Where appropriate, the design engineer is directed to primary references for additional details, as well as to several figures in this TM for typical layouts and design details. As needed, assumptions underlying the selection of design elements will be noted.

C-2. Design Example

a. Site Scenario. The general location, size, hydrogeologic conditions, climate, and anticipated wastes for this hypothetical installation are summarized below:

- A 2,000-acre installation in the Midwest characterized by rolling hills above an adjacent valley region.
- Located within Seismic Zone 2, as defined by paragraph 3-4 of TM 5-809-10.
- Annual precipitation of 39 inches and mean total snowfall of 17 inches.
- Average daily maximum temperature of 80°F for May through October and average daily minimum of less than 32°F for December, January and February.
- Annual pan evaporation is 45 inches, with 76 percent of the evaporation occurring from May through October.
- 100-year, 24-hour design storm of 5.8 inches.
- Design freezing index of 500 for the region.
- Silty clay topsoil 1 to 3 feet in thickness.
- Glacial till clayey soils interspersed with discontinuous sand stringers to a depth of 200 feet over a shale bedrock.
- Ground water (which occurs within on-site swales) found at depths ranging from 90 to 120 feet below the surface; flow direction is toward the adjacent valley.
- Ground water of drinking water quality exists in only limited amounts; it is not a measurable source of recharge to the valley aquifer.
- Liquid wastes (designated for the surface impoundment) consist of acidic wastewater; maximum volume of liquid waste storage is 2,000,000 gallons.

- Solid hazardous wastes (for landfilling) consist of (1) incinerator ash containing lead (10 cubic yards (cy) per day), and (2) sludges produced by an acid neutralization process (20 cy per day).

b. Pre-design evaluation. Given the scenario described above, the design engineer will initially review available documents and evaluate site conditions and waste types and quantities. In addition, the engineer will perform additional hydrogeologic services identified in paragraph 3-3 of this TM including geologic mapping of the proposed site locations, drilling borings and excavating test pits, and testing soils for geotechnical properties. Based on the available information, logs of borings, and additional test results, engineering properties of soils and related pre-design calculations and evaluations will be made; these are summarized below:

(1) Available data verify that both the surface impoundment and the landfill can be developed with adequate vertical separation, and hydraulic separation from ground water. Construction areas are well above the 100-year flood plain. Both units allow excavations which can provide needed topsoils, clayey soils for soil berms and secondary liners, and soil cover needs for the operation and closure of the landfill.

(2) Tests of clayey soils determine that they exhibit a Liquid Limit of 40 and a PI of 18, a dry density of 105 pcf, an optimum moisture content of 19 percent, and a permeability of 3×10^{-8} cm/sec at optimum plus 4 percent. When they were subjected to the hazardous wastes to be contained, the clayey soils exhibited a permeability of 5×10^{-8} cm/sec.

(3) Based on stability analysis, earthfill berms or dikes constructed with on-site clayey soils will have an adequate factor of safety for stability under static and seismic loadings, provided they are constructed with a 12-foot-minimum crest width, a maximum height of 25 feet, and side slopes of 3:1 or less (see para 3-3).

(4) Based on current publications on compatibility testing (EPA SW-870), supportive information from several lining manufacturers, and accelerated testing (using the waste to be contained), the following liners were determined to be suitable for the project: chlorinated polyethylene (CPE), chlorosulfonated polyethylene (CSPE), and high density polyethylene (HDPE) (see para 6-3).

(5) In accordance with the Universal Soil Loss Equation, (EPA SW-867, page 37) $A = RKLSCP$, where

(eq C-1)

R, the rainfall erosion index for the location, is
175

- K, the erodibility factor for the above topsoil, is 0.21
- C, the cover factor for well established grass-like plants is, 0.01
- P, the erosion control practice for normal conditions, is 1.0
- A, the soil loss in tons/acre/year, limited to < 2 per RCRA guidance documents

(a) The LS landslope factor must be < 5.4; therefore the following design slopes could be used:

Slope	Slope Length	Vertical Height
3:1	34	11
4:1	85	21
5:1	180	35

(b) Based upon a design freezing index of 500 for the region, the silty clay topsoil when barren can freeze to a depth of about 2 feet (EPA SW-867, page 29).

(6) The sludges produced by the acid neutralization process can be solidified by adding nonbiodegradable absorbents or by solar drying; when absorbents are used, the resultant waste volume is doubled. The net May through October evaporation rate of 24 inches allows solar drying (the net annual evaporation of 5 inches precludes use of solar evaporation ponds).

c. Required design elements and procedures.

(1) Design elements for the surface impoundment include:

- a dike along two perimeters of the impoundment
- run-on control ditches
- a double liner system with leak detection which includes a protective cover, a primary synthetic liner, a leak detection system, and a secondary soil liner.
- inlet and outlet pipes (12-inch-diameter pipes to be provided; these will be equipped with automatic flow controls to prevent overtop ping).
- ground-water monitoring wells

(2) Design elements for the landfill include:

- an earthfill berm along the end of the landfill
- run-on/run-off control facilities
- a double liner system with leak detection, which includes a leachate collection system, a primary synthetic liner, a leak detection system and a secondary soil liner
- final cover (for closure)
- ground-water monitoring wells

(3) Figure 5-1 illustrates layouts for typical surface impoundments and a landfill, and figures 5-2, 6-1, 6-2, 6-5, 6-6, 6-7 and 6-10 show design details.

(4) Proposed dimensions for the 2, 000, 000 gallon capacity surface impoundment are a 10-foot liquid depth with a 2-foot freeboard, 3:1 construction slopes, base dimensions 100 feet wide by 180 feet long (in-

board crest-to-crest dimensions are 172 feet by 252 feet).

(5) Proposed dimensions of the 200, 000 cy landfill are approximately 20 feet deep, with inboard crest-to-crest dimensions 400 feet wide by about 800 feet long. The size of the landfill is based upon the following disposal volumes:

Containerized ash	10 cy/day
Sludges (20 cy/day, with 1/2 dried without volume change, and 112 solidified by absorbents, with a doubled volume)	30 cy/day
Operational soil cover needs (2:1 waste:soil ratios for 40 cy of waste)	20 cy/day
TOTAL	60 cy/day 1,200 cy/mo 14,400 cy/yr ²

(6) When 100-year flood levels are determined to be above the project area, earthfill levees of compacted impervious soil can be constructed to prevent flooding (see figure 6-1).

(7) Liner systems details for this hypothetical facility (including leak detection and leachate collection systems) are illustrated in figures 6-2 and 6-5. The proposed incorporation of a secondary soil liner for the two waste units in this example problem (and for any waste unit) should be based upon the premise that there is little or no potential for ground-water flow into the detection system. The construction of project earthfills and proposed clay liners (in accordance with placement requirements described in paragraph 6-3 and in EPA SW-870) will provide an adequate secondary liner and soil subbase for other liner elements at this facility.

(a) Given a DA requirement to limit the number of field seams and locate such seams to minimize the potential for leakage, field panel widths of approximately 100 feet for the primary synthetic liner are proposed. The liner material for the two waste units will be restricted to CPE and CSPE, based upon compatibility testing and panel size needs. The actual panel sizes and layouts are contingent upon required spacing for the leak detection and leachate collection systems and will be developed after selecting these design dimensions.

(b) Calculations for the leak detection and leachate collection systems, and material selections, are:

- Infiltration rates for system design:
—Assuming seepage through the secondary

¹ A desired service life of 15 years requires about 200,000 cubic yards of capacity.

² Based upon 5 days/week, 20 days/month, 240 days/year.

liner due to a 10-foot head of liquid acting on the clay liner:

$$Q = KiA \text{ (Darcy's Law) where} \quad (\text{eq C-2})$$

$$q = \frac{Q}{A}$$

$i =$ (liquid head plus liner thickness/liner thickness)

$$q = Ki$$

$$q = Ki = (1 \times 10^{-7} \text{ cm/sec}) \left(\frac{2835 \text{ ft/day}}{\text{cm/sec}} \right) \left(\frac{13 \text{ feet}}{3 \text{ feet}} \right) = 1.23 \times 10^{-3} \text{ ft/day (0.4 inches/month)}$$

—Assuming infiltration through a clay loam soil cover of $q = 2.6$ inches/month (EPA SW-870, page 267).

- Pipe spacing for leak detection system (L), the collection drain spacing, for a 1-foot-thick sand layer, $K \geq 1 \times 10^{-3}$ cm/sec, can be calculated:

$$Q = KiA$$

$$Q = q(L)(1) = 1.23 \times 10^{-3}L$$

$$K = 1 \times 10^{-3} \text{ cm/sec}$$

$$i = \frac{(1 + 0.01L)}{L/2}$$

$$A = 1 \text{ foot} \times 1 \text{ foot}$$

$$(L) = \left(\frac{1}{1.23} \times 10^{-3} \right) (1 \times 10^{-3}) (2835) \frac{(1 + .01L)(1 \times 1)}{L/2}$$

$$L^2 - 46.1L - 4610 = 0$$

$$L = 95 \text{ feet}$$

Therefore sand with a permeability slightly greater than 1×10^{-3} cm/sec would be required in connection with a 100-foot panel/pipe spacing interval.

- Pipe spacing for leachate collection system for a 1-foot-thick sand layer, $K \geq 1 \times 10^{-3}$ cm/sec, assuming infiltration through the final cover at 2.6 inches/month

$$L = \left(\frac{1}{7.22 \times 10^{-3}} \right) 2.835 \left(\frac{(1 + .01L)}{.5L} \right) (1 \times 1)$$

$$L = 32 \text{ feet}$$

For a 1-foot-thick sand layer $K \geq 1 \times 10^{-2}$ cm/sec, 2.6 inches/month infiltration

$$L = 136 \text{ feet}$$

Therefore sand with $K \geq 1 \times 10^{-2}$ cm/sec could be used in connection with 100-foot panel/pipe spacing interval.

- Piping ratio between clay liner and sand, using design criteria for plastic clay (Cedergren, page 181):

$$\frac{D_{15} \text{ of sand}}{D_{85} \text{ of clay}} < 5^3 \text{ (piping ratio)}$$

$$\frac{D_{60} \text{ of sand}}{D_{10} \text{ of sand}} < 20 \text{ for single layer filter}$$

with sand gradation guideline specs:

$$D_{10} \text{ of sand} = \#50 = 0.295 \text{ mm}$$

$$D_{15} \text{ of sand} = \#50 = 0.295 \text{ mm}$$

$$D_{60} \text{ of sand} = \#16 = 1.168 \text{ mm}$$

$$D_{85} \text{ of clay} = \#200 = .074 \text{ mm}$$

$$\frac{D_{15}}{D_{85}} = \frac{.295}{.074} = 4$$

$$\frac{D_{60}}{D_{10}} = \frac{1.168}{.295} = 4$$

Thus the proposed sand drainage layer can be used without any geotextile filter cloth or fabric.

- Pipe slot size
Using design criteria of:

$$\frac{85\% \text{ size of filter materials}}{\text{slot width}} > 1.2$$

For rounded clean drain rock:

$$D_{85} = 3/8 \text{ inches}$$

$$\text{Maximum slot width} = \frac{3/8}{1.2} = .31 \text{ inch}$$

For sand:

$$D_{85} = \#4 \text{ sieve} = .185 \text{ inches}$$

$$\text{Maximum slot width} = .185/1.2 = .154 \text{ inch}$$

³ "If a protected soil is a plastic clay, the piping ratio often can be much higher than 5 or 10, as indicated by U.S. Army Corps of Engineers practice previously noted," Cedergren, Harry R., 1977. *Seepage, Drainage, and Flow Nets*, p 183.

Standard slot size selected for the piping is 0.102 for both sand and drain rock drainage layers.

- Pipe capacity, leak detection system:

For the proposed pond with a width of 100 feet, and pipe spacing of 100 feet, and $q = 1.23 \times 10^{-3}$ ft/day

$$Q \text{ req'd} = qA = 1.23 \times 10^{-3} (100 \text{ feet})(100 \text{ feet})$$

(eq C-3)

$$= \frac{12.3 \text{ ft}^3}{\text{day}} \times \frac{\text{day}}{24 \text{ hr}} \times 3600 \frac{\text{hr}}{\text{sec}}$$

$$= 1.42 \times 10^{-4} \text{ cfs}$$

For 2-inch pipe:

$$Q = \frac{1.49}{n} A R^{2/3} S^{1/2} \text{ (Manning's equation),}$$

(eq C-4)

where

$$n = .01$$

$$s = .005$$

$$R = \frac{D}{4} = .5 \text{ inch (flowing full)}$$

$$= .042 \text{ foot}$$

$$\therefore Q = \frac{1.49}{.01} (.022)(.042)^{2/3} (.005)^{1/2}$$

$$= .028 \text{ cfs}$$

$Q > Q \text{ req'd}$,

therefore 2-inch pipe is adequate

- Pipe capacity for leachate collection system
For a landfill with a base width up to 400 feet, and a pipe spacing of 100 feet and $Q = 7.22 \times 10^{-3}$ ft/day, "Q required" can be calculated following the approach described for the leak detection system. Although such calculations show that a 2-inch pipe could also be used for leachate collection, a 4-inch pipe will be installed to ensure adequate capacity for removing any leachate that might accumulate within the landfill during operations.
- Pipe structural stability:
Positive projecting installation for maximum vertical pressure (EPA SW-870, page 378)

For maximum vertical pressure:

$$\delta_v = \text{max. vertical pressure}$$

$$\delta_v = W_f H_f + wz, \text{ where}$$

(eq C-5)

W_f , density of refuse fill, is 50 pcf
 H_f , height of fill above pipe, is 40 feet max.
 w , density of backfill (drain rock), is 110 pcf
 z , height of backfill (above pipe), is 1 foot
 $\Delta y/B_c$, allowable pipe (deflection), is .05 to .1
 E^1 , passive soil modules, is 90% \pm relative compaction

$$\therefore \delta_v = 50(40) + (110)(1) = 2110 \text{ psf}$$

$$= 14.7 \text{ psi}$$

Adjustment for pipe slots:

for slot size = .102 inch → 32 rows of slots
 slot space = .25 inch per foot

$$L_p = \frac{\text{Length of slots (inches)}}{\text{foot of pipe (ft)}} = 3.264 \text{ in/ft}$$

Pipe stress (EPA SW-870, page 382) is:

$$(\delta_v) \text{ design} = \frac{12}{12 - L_p} \times (\delta_v) \text{ actual}$$

$$= \frac{12}{12 - 3.264} (14.7 \text{ psi})$$

$$= 20.2 \text{ psi}$$

(eq C-6)

$$\frac{\delta_v}{\Delta y/B_c}$$

for $\Delta y/B_c = 0.05$

$$\frac{\delta_v}{\Delta y/B_c} = \frac{20.2}{.05} = 404$$

for $\Delta y/B_c = 0.1$

$$\frac{\delta_v}{\Delta y/B_c} = \frac{20.2}{.1} = 202$$

From the monograph in figure V-6, EPA SW-870:

For $E^1 = 700 \text{ psi}$

and $\frac{\Delta y}{B_c} = .05$ 2" Sch 40 (extrapolated solution) or 4" Sch 80

for $\frac{\Delta y}{B_c} = .1$ 2" Sch 40
 4" Sch 40

Selected pipes (with allowable deflections of 5 percent) are 2-inch Schedule 40 PVC pipe, (or equivalent alternative), for the leak detection system, and 4-inch Schedule 80 PVC pipe (or equivalent alternative) for the leachate collection system.

(c) Based upon these calculations, the design engineer will develop liner panel installation plans with leak detection and leachate collection networks for the surface impoundment. Design elements will include:

- A base grade configuration which slopes at 0.5 percent across the 100-foot width of the pond, with a crest-to-trough distance of 50 feet along the pond's 180-foot length to accommodate the leak detection pipe network.
- Two-inch slotted detection pipes in trenches over the troughs, with risers up the side slopes within the drainage layer.
- A 36-mil reinforced primary synthetic liner.
- A 1-foot sand/riprap protective cover.

(d) Based upon the calculations outlined above, liner, leak detection and leachate collection design elements for the landfill include:

- A base grade configuration which slopes at 0.5 percent across the 400-foot width of landfill, with crest-to-trough distances of 50 feet along the landfill's length to accommodate the leak detection pipe network.
- A trough along the lower side of the landfill to accommodate a collection drainpipe to connect leachate laterals to a sump area.
- Two-inch slotted detection pipe, as described above for the surface impoundment.
- A 36-mil reinforced primary synthetic liner.
- Four-inch slotted leachate collection pipes surrounded with rounded drain rock, within the 1-foot thick drainage layer.

(8) Gas control measures for the facility will be limited to a few pipe vents for the surface impoundment. The absence of organic materials below or within the landfill and surface impoundments minimizes the likelihood of air pressure developing below proposed liners. Nevertheless, since even a small amount of gas pressure can lift synthetic liners in impoundments, atmospheric pipe vents should be considered at selected perimeter locations of the surface impoundment.

(9) Surface water control features for the proposed surface impoundment and landfill will be similar to those illustrated in figure 5-1. They will include ditches and drainage pipes normally used to prevent flow into active portions of waste units. Upon closure, the run-on control ditches of the landfill carry run off from closed final cover areas as well.

(a) Run-on control ditches, V ditches and the typical trapezoidal ditch shown in figure 6-7, can be constructed with adequate slopes to carry run-off volumes. For example, with contributory areas of less than 5 acres, a peak discharge of less than 20 cfs results from the 100-year design storm. (SCS run-off method, with a type C soil classification, a CN value of

70 for grasslands and a steep slope, $S > 8$ percent.)

(b) A sedimentation basin will be established for the landfill construction area; in addition, sediment control facilities will be utilized at all temporary construction sites.

(c) For the active waste area of the landfill, temporary containment berms can be used to retain run off for treatment when limited run off volumes are involved. By limiting the active waste lift and containment area for the proposed landfill to an area about 200 feet long and 100 feet wide, the run off from the 100-year storm is 72, 000 gallons. This is based on 100 percent run off from a 5.8-inch intensity rainstorm over the active area.

(d) Due to limited evaporation, the run off from active areas should be discharged to the surface impoundment for subsequent treatment. If no additional rainfall run-off control measures are selected (i.e., tarps, restricted operations during rainfall periods), the annual rainfall of 39 inches would produce about 500,000 gallons of liquid.

(10) Ground-water monitoring wells will be installed in accordance with federal regulations, one hydraulically upgradient of the facility (to provide background water quality data) and three downgradient to detect contaminant discharge. Well design and sampling procedures will reflect details presented in paragraph 8-3.

(11) Special design elements needed for this facility are impoundment dikes and overtopping controls (part of the plant equipment), with a 2-foot freeboard. Addressed under liner details are requirements for developing adequate anchor pads for the "over-the-line" inlet/outlet pipes and appurtenant structures for flow control. The only penetrations allowed will be liner "boots" clamped to penetrations for the leak detection and leachate collection pipe risers, and gas vents within the berm crest of the levee of the surface impoundment (see EPA SW-870, figure IV-22, page 371). No wind dispersal provisions will be needed since the ash is containerized.

(12) As segments of the fill are brought to final grade, final cover for the proposed landfill will be placed to minimize infiltration of precipitation. As stated in EPA SW-870, table V-5, page 267, water balance calculations result in a 2.6-inch maximum monthly infiltration for a 2-foot clay cover. Final cover slopes (selected based on LS factors) will be a minimum 3 percent and 5:1 or less; assuming proper placement procedures, settlement is not expected to pose a design constraint. The final cover system will consist of a 20-mil PVC liner placed over a 2-foot soil liner (permeability of 1×10^{-7} cm/sec), a drainage layer of sand, and topsoil to facilitate vegetative growth. General details for the final cover are illustrated in figures 6-7 and 6-10.

BIBLIOGRAPHY

- Braunstein, J., 1973. *Underground Waste Management and Artificial Recharge*, Vol. 2, American Association of Petroleum Geologists.
- Brown, K. W., June 1983. *Landfills in the Future*. Public Works, 200 South Boward Street, Ridgewood, New Jersey 07451.
- Cedergren, Harry R., 1977. *Seepage, Drainage and Flow Nets*, John Wiley and Sons, Inc., One Wiley Drive, Somerset, New Jersey 08873.
- Cheremisinoff, N. P., P. N. Cheremisinoff, F. Ellerbusch, A. J. Perna, 1979. *Industrial and Hazardous Wastes Impoundment*. Ann Arbor Science.
- Collins, T. G. and Newkirk, D. D., 1982. *The Use of Geotextile Fabrics in Pond Construction Beneath an Impermeable Membrane*. Crown Zellerbach Corporation, Northeast 4th and Adams Street, Camas, Washington 98607.
- Cook, T. D., ed., 1972. *Underground Waste Management and Environment Implications*. American Association of Petroleum Geologists.
- EMCON Associates, 1980. *Methane Generation and Recovery from Landfills*. Ann Arbor Science, 10 Tower Office Park, Woburn, Massachusetts 01801.
- Engineering Science, May 1982. *Comparative Evaluation of Incinerators and Landfills*. Engineering Science, Inc., 150 N. Santa Anita Avenue, Arcadia, California 91006.
- Freeze, R. A. and J. A. Cherry, 1979. *Groundwater*. Prentice-Hall, Inc., Englewood Cliffs, New Jersey 07632.
- Geraghty and Miller, Inc., 1982. *Guidance Document on Mechanical Integrity Testing of Injection Wells*. Geraghty and Miller, Inc., North Shore Atrium, 6800 Jericho Turnpike, Syosset, New York 11791.
- Geraghty and Miller, Inc. and Booz, Allen and Hamilton, Inc., 1982. *Injection Well Construction Practices and Technology*. Geraghty and Miller, Inc., North Shore Atrium, 6800 Jericho Turnpike, Syosset, New York 11791.
- Kays, W. B., 1977. *Construction of Linings for Reservoirs, Tanks, and Pollution Control Facilities*. John Wiley and Sons, Inc., One Wiley Drive, Somerset, New Jersey 08873.
- National Water Well Association, 1982. *Aquifer Restoration and Ground-Water Rehabilitation, Proceedings of the Second National Symposium on Aquifer Restoration and Ground-Water Monitoring*. National Water Well Association, 500 W. Wilson Bridge Road, Worthington, Ohio 43085.
- Overcash, M. R. and D. Pal, 1981. *Design of Land Treatment Systems for Industrial Wastes-Theory and Practice*. Ann Arbor Science, 230 Collingwood, P.O. Box 1425, Ann Arbor, Michigan 48105.
- Parr, J. F., Marsh, P. B., and J. M. Kla, 1983. *Land Treatment of Hazardous Wastes*. Noyes Data Corporation, Mill Road at Grand Avenue, Park Ridge, New Jersey 07656.
- Rankilor, P. R., 1981. *Membranes in Ground Engineering*. John Wiley and Sons, Inc., One Wiley Drive, Somerset, New Jersey 08873.
- Sittig, M., 1979. *Landfill Disposal of Hazardous Wastes and Sludges*. Noyes Data Corporation.
- Yrjanainen, G., July 1975. "Sediment Basin Design," *Water and Sewage Works*, University Micro Films International, 300 N. Zeeb Road, Department PR, Ann Arbor, Michigan 48106.

The proponent agency of this publication is the Office of the Chief of Engineers, United States Army. Users are invited to send comments and suggested improvements on DA Form 2028 (Recommended Changes to Publications and Blank Forms) direct to HQDA DAEN-ECE-G, WASH DC 20314.

By Order of the Secretary of the Army:

Official:

ROBERT M. JOYCE
Major General, United States Army
The Adjutant General

E. C. MEYER
General, United States Army
Chief of Staff

Distribution:

To be distributed in accordance with DA Form 12-34B, TM 5-800 Series: Requirements, for ENGINEERING AND DESIGN FOR REAL PROPERTY FACILITIES.

* U.S. GOVERNMENT PRINTING OFFICE: 1984-461-028:10038

CANCELLED

RECOMMENDED CHANGES TO EQUIPMENT TECHNICAL PUBLICATIONS



THEN... JOT DOWN THE DOPE ABOUT IT ON THIS FORM, CAREFULLY TEAR IT OUT, FOLD IT AND DROP IT IN THE MAIL!

SOMETHING WRONG WITH THIS PUBLICATION?

FROM: (PRINT YOUR UNIT'S COMPLETE ADDRESS)

DATE SENT

PUBLICATION NUMBER

PUBLICATION DATE

PUBLICATION TITLE

BE EXACT... PIN-POINT WHERE IT IS

PAGE NO.

PARA-GRAPH

FIGURE NO.

TABLE NO.

IN THIS SPACE TELL WHAT IS WRONG AND WHAT SHOULD BE DONE ABOUT IT:

TEAR ALONG PERFORATED LINE

PRINTED NAME, GRADE OR TITLE, AND TELEPHONE NUMBER

SIGN HERE:

DA FORM 2028-2
1 JUL 79

PREVIOUS EDITIONS ARE OBSOLETE.

P.S.—IF YOUR OUTFIT WANTS TO KNOW ABOUT YOUR RECOMMENDATION MAKE A CARBON COPY OF THIS AND GIVE IT TO YOUR HEADQUARTERS.

CANCELLED

UNIFIED FACILITIES CRITERIA (UFC)

HAZARDOUS WASTE LAND DISPOSAL/LAND TREATMENT FACILITIES

Any copyrighted material included in this UFC is identified at its point of use. Use of the copyrighted material apart from this UFC must have the permission of the copyright holder.

U.S. ARMY CORPS OF ENGINEERS (Preparing Activity)

NAVAL FACILITIES ENGINEERING COMMAND

AIR FORCE CIVIL ENGINEER SUPPORT AGENCY

Record of Changes (changes are indicated by \1\ ... /1/)

Change No.	Date	Location

This UFC supersedes TM 5-814-7, dated 29 November 1984. The format of this UFC does not conform to UFC 1-300-01; however, the format will be adjusted to conform at the next revision. The body of this UFC is the previous TM 5-814-7, dated 29 November 1984.

FOREWORD

\1\

The Unified Facilities Criteria (UFC) system is prescribed by MIL-STD 3007 and provides planning, design, construction, sustainment, restoration, and modernization criteria, and applies to the Military Departments, the Defense Agencies, and the DoD Field Activities in accordance with [USD\(AT&L\) Memorandum](#) dated 29 May 2002. UFC will be used for all DoD projects and work for other customers where appropriate. All construction outside of the United States is also governed by Status of forces Agreements (SOFA), Host Nation Funded Construction Agreements (HNFA), and in some instances, Bilateral Infrastructure Agreements (BIA.) Therefore, the acquisition team must ensure compliance with the more stringent of the UFC, the SOFA, the HNFA, and the BIA, as applicable.

UFC are living documents and will be periodically reviewed, updated, and made available to users as part of the Services' responsibility for providing technical criteria for military construction. Headquarters, U.S. Army Corps of Engineers (HQUSACE), Naval Facilities Engineering Command (NAVFAC), and Air Force Civil Engineer Support Agency (AFCEA) are responsible for administration of the UFC system. Defense agencies should contact the preparing service for document interpretation and improvements. Technical content of UFC is the responsibility of the cognizant DoD working group. Recommended changes with supporting rationale should be sent to the respective service proponent office by the following electronic form: [Criteria Change Request \(CCR\)](#). The form is also accessible from the Internet sites listed below.

UFC are effective upon issuance and are distributed only in electronic media from the following source:

- Whole Building Design Guide web site <http://dod.wbdg.org/>.

Hard copies of UFC printed from electronic media should be checked against the current electronic version prior to use to ensure that they are current.

AUTHORIZED BY:



DONALD L. BASHAM, P.E.
Chief, Engineering and Construction
U.S. Army Corps of Engineers

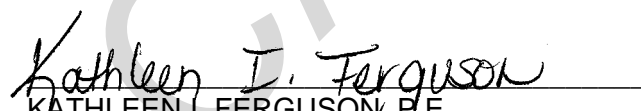

KATHLEEN I. FERGUSON, P.E.
The Deputy Civil Engineer
DCS/Installations & Logistics
Department of the Air Force



DR. JAMES W. WRIGHT, P.E.
Chief Engineer
Naval Facilities Engineering Command



Dr. GET W. MOY, P.E.
Director, Installations Requirements and
Management
Office of the Deputy Under Secretary of Defense
(Installations and Environment)