

UNIFIED FACILITIES CRITERIA (UFC)

O&M: AIRFIELD DAMAGE REPAIR



APPROVED FOR PUBLIC RELEASE: DISTRIBUTION UNLIMITED

UNIFIED FACILITIES CRITERIA (UFC)

CRITERIA FORMAT STANDARD

Any copyrighted material included in this UFC is identified at its point of use. Use of the copyrighted material apart from this UFC must have the permission of the copyright holder.

U.S. ARMY CORPS OF ENGINEERS

NAVAL FACILITIES ENGINEERING COMMAND

AIR FORCE CIVIL ENGINEER SUPPORT AGENCY (Preparing Activity)

Record of Changes (changes are indicated by \1\ ... /1/)

Change No.	Date	Location

FOREWORD

The Unified Facilities Criteria (UFC) system is prescribed by MIL-STD 3007 and provides planning, design, construction, sustainment, restoration, and modernization criteria, and applies to the Military Departments, the Defense Agencies, and the DoD Field Activities in accordance with [USD\(AT&L\) Memorandum](#) dated 29 May 2002. UFC will be used for all DoD projects and work for other customers where appropriate. All construction outside of the United States is also governed by Status of forces Agreements (SOFA), Host Nation Funded Construction Agreements (HNFA), and in some instances, Bilateral Infrastructure Agreements (BIA.) Therefore, the acquisition team must ensure compliance with the more stringent of the UFC, the SOFA, the HNFA, and the BIA, as applicable.

UFC are living documents and will be periodically reviewed, updated, and made available to users as part of the Services' responsibility for providing technical criteria for military construction. Headquarters, U.S. Army Corps of Engineers (HQUSACE), Naval Facilities Engineering Command (NAVFAC), and Air Force Civil Engineer Support Agency (AFCESA) are responsible for administration of the UFC system. Defense agencies should contact the preparing service for document interpretation and improvements. Technical content of UFC is the responsibility of the cognizant DoD working group. Recommended changes with supporting rationale should be sent to the respective service proponent office by the following electronic form: [Criteria Change Request \(CCR\)](#). The form is also accessible from the Internet sites listed below.

UFC are effective upon issuance and are distributed only in electronic media from the following source:

- Whole Building Design Guide web site <http://dod.wbdg.org/>.

Hard copies of UFC printed from electronic media should be checked against the current electronic version prior to use to ensure that they are current.

AUTHORIZED BY:



DONALD L. BASHAM, P.E.
Chief, Engineering and Construction
U.S. Army Corps of Engineers



DR. JAMES W. WRIGHT, P.E.
Chief Engineer
Naval Facilities Engineering Command



KATHLEEN I. FERGUSON, P.E.
The Deputy Civil Engineer
DCS/Installations & Logistics
Department of the Air Force



Dr. GET W. MOY, P.E.
Director, Installations Requirements and
Management
Office of the Deputy Under Secretary of Defense
(Installations and Environment)

CONTENTS

	<u>Page</u>
CHAPTER 1 INTRODUCTION	
Paragraph 1-1	PURPOSE AND SCOPE 1-1
1-2	APPLICATION 1-1
CHAPTER 2 REQUIREMENTS	
Paragraph 2-1	SPALL REPAIRS 2-1
2-1.1	Materials Currently in Use 2-1
2-1.2	Technical Representatives 2-1
2-1.3	Repair/Acceptance Process 2-1
2-2	EXPEDIENT/SUSTAINMENT CRATER REPAIRS 2-1
2-2.1	Repair Methods Currently in Use 2-1
2-2.2	Criteria for Selecting Best Repair Options 2-3
2-2.3	Equipment and Manpower Requirements 2-3
2-2.4	Crater Repair Procedures 2-5
2-3	FOD COVERS 2-15
2-3.1	Army FOD Cover Assembly Procedures 2-15
2-3.2	Air Force FFM 2-15
2-4	AM-2 ALUMINUM MAT 2-18
2-4.1	Navy/Marine Corps 2-18
2-4.2	Air Force 2-18
2-5	REPAIR EVALUATION METHODS 2-21
2-5.1	Acceptance Criteria 2-21
2-5.2	Airfield Certification 2-21
2-6	PERMANENT REPAIRS 2-22
GLOSSARY G-1
APPENDIX A	REFERENCES A-1
APPENDIX B	AIRFIELD DAMAGE REPAIR LOG B-1

FIGURES

<u>Figure</u>	<u>Title</u>	
2-1	Crushed Stone Repair	2-7
2-2	Sand Grid Repair	2-9
2-3	Stone and Grout Repair	2-11
2-4	Concrete Cap Repair	2-13
2-5	Pedestal Designs	2-14

TABLES

<u>Table</u>	<u>Title</u>
2-1	Repair Suitability for Airfield Surfaces and Aircraft Types 2-2
2-2	Stone and Grout Mix Properties 2-10

CANCELLED

CHAPTER 1

INTRODUCTION

1-1 PURPOSE AND SCOPE

This document outlines the various services' (Army, Navy, Marine Corps, Air Force) ADR concept of operations. Recent operations identified the lack of familiarity and consistency in ADR procedures, equipment, material, and unified pavement specifications. This document is the first effort toward developing joint ADR guidance in the context of recent operations.

Note: This document will be revised as additional information on Navy and Marine Corps FRP panel mat FOD covers becomes available.

ADR encompasses more than just pavement repair. Damage assessment, explosive ordnance reconnaissance, MOS selection, repair quality criteria, aircraft arresting system and utility system repairs are just a few of the areas that must also be considered. **This document only addresses airfield pavement repairs.** All branches of service accomplish pavement repair in a similar manner. The major differences occur in the final 457 to 610 millimeters (18 to 24 inches) of crater repair and capping due to mission differences, team configuration, and available resources. Understanding the various services' repair procedures will expedite the re-repair and/or upgrade of those repairs by follow-on forces, regardless of branch of service. Extensive efforts are still required to find the ultimate answers to pavement repair problems and compatibility issues with new aircraft.

Note: The use of the name or mark of any specific manufacturer, commercial product, commodity, or service in this publication does not imply endorsement by the Department of Defense.

1-2 **APPLICATION.** All Department of Defense (DOD) organizations responsible for ADR planning, design, construction, maintenance, repair, evaluation, and training. The current international situation dictates a flexible force capable of ADR. Both the initial and follow-on force, regardless of branch of service, must be familiar with each services' repair procedures, techniques, and materials in order to keep an airfield operational. Familiarity with the different repair procedures will significantly expedite maintenance, upgrades, and permanent repairs.

CHAPTER 2

REQUIREMENTS

2-1 SPALL REPAIRS

2-1.1 **Materials Currently in Use.** Numerous commercial-off-the-shelf (COTS) materials are available. Some of these materials have been tested and approved for DOD use while others have not. Before any material can be used on DOD airfields it must be certified for use. Contact your service technical representative for the appropriate material and installation procedures for your particular application.

2-1.2 Technical Representatives

2-1.2.1 **Army.** Engineering Research and Development Center, Geotechnical and Structures Laboratory, Airfields and Pavements Branch, Internet <http://pavement.wes.army.mil/>, DSN 446-2731, commercial (601) 634-2731.

2-1.2.2 **Navy.** Naval Facilities Engineering Service Center, Code ESC63, Internet <http://www.nfesc.navy.mil/>, DSN 551-1447, commercial (805) 982-1447, FAX (805) 982-1074.

2-1.2.3 **Marine Corps.** Expeditionary Airfields (EAF) Aircraft Rescue and Firefighting (ARFF), HQMC ASL-38, DSN 224-1835, commercial (703) 614-1835/1028/2742, FAX (703) 697-7473.

2-1.2.4 **Air Force.** Headquarters Air Force Civil Engineer Support Agency, Technical Support Directorate (HQ AFCESA/CES), Internet <http://www.afcesa.af.mil/>, DSN 523-6334, commercial (850) 283-6334.

2-1.3 Repair/Acceptance Process

2-1.3.1 Locate the damage.

2-1.3.2 The repair material must be compatible with the existing surface being repaired.

2-1.3.3 Prepare the damaged area and mix the repair material in accordance with the manufacturer's instructions. Adjust the preparation and mixing procedures in accordance with environmental conditions and experience.

2-1.3.4 Place the material and level as required.

2-2 EXPEDIENT/SUSTAINMENT CRATER REPAIRS

2-2.1 Repair Methods Currently in Use

Table 2-1. Repair Suitability for Airfield Surfaces and Aircraft Type

ADR Methods						
Current Repair Methods	Runway Repair		Taxiway/Apron Repair		Taxiway/Apron Expansion	
	Expedient	Sustain	Expedient	Sustain	Expedient	Sustain
Crater Repair						
Crushed stone with FOD cover	X ⁽¹⁾		X ⁽¹⁾			
Crushed stone without FOD cover	X ⁽²⁾		X ⁽²⁾			
Sand grid with FOD cover	X ⁽¹⁾		X ⁽¹⁾			
Stone and grout		X		X		
AM-2 mat	X ⁽³⁾	X ⁽³⁾	X	X	X	X
Rapid-set materials	X	X	X	X	X	X
Concrete cap		X		X		X
Asphalt		X		X		X
FOD Covers						
FRP (Army)	X ⁽¹⁾		X ⁽¹⁾			
FRP (Navy)	X ⁽¹⁾		X ⁽¹⁾			
FFM (Air Force)	X ⁽¹⁾		X ⁽¹⁾			
Semi-prepared Surfaces						
Unsurfaced					X ⁽⁴⁾	X ⁽⁴⁾
Stabilized surface	X ⁽⁴⁾		X ⁽⁴⁾		X ⁽⁴⁾	X ⁽⁴⁾

Notes:

(1) Folded fiberglass mat (FFM)/fiberglass reinforced plastic (FRP) foreign object damage (FOD) covers are suitable only for fighter aircraft and C-130 operations. These FOD covers are not approved for C-17, C-5 Galaxy, C-141 Starlifter, KC-10 Extender, and KC-135 Stratotanker operations.

(2) Crushed stone repairs without FOD covers are approved for C-17, C-5, C-141, KC-10, and KC-135 operations.

(3) AM-2 mat is suitable as a runway surface only for fighter aircraft and C-130 operations, and then only if accomplished as a flush repair and installed and certified in accordance with Naval Air Systems Command Instruction

(NAVAIRINST) 13800.12B, *Certification of Expeditionary Airfield AM-2 Mat Installations, Aircraft Recovery Equipment, Visual/Optical Landing Aids, and Marking/Lighting Systems*, NAVAIR 51-60A-1, *AM-2 Airfield Landing Mats and Accessories; Installation, Maintenance, Repackaging, & Illustrated Parts Breakdown*, and Naval Air Warfare Center Aircraft Division Lakehurst (NAWCADLKE)-MISC 48J200-0011, *Expeditionary Airfield AM-2 Mat Certification Requirements*. AM-2 is not an approved runway surface for C-17, C-5, C-141, KC-10, and KC-135 operations.

(4) Unsurfaced and/or stabilized surfaces are suitable for C-130 and C-17 operations.

2-2.2 Criteria for Selecting Best Repair Options

2-2.2.1 **Aircraft Type and Load.** Each aircraft has distinct characteristics (e.g., wing span, tire pressure, load capacity, braking mechanism) that must be known when choosing the type of repair to accomplish.

2-2.2.2 **Available Material.** The type and quantity of material (e.g., backfill, crushed stone, fiberglass mat, spall) available for a repair.

2-2.2.3 **Available Equipment.** The type and quantity of various pieces of construction equipment (e.g., dozer, front-end loader, roller) available for a repair.

2-2.2.4 **Repair Quality Criteria (RQC).** A single number representing the maximum allowable repair height in inches various aircraft can tolerate on an MAOS. See Technical Order (T.O.) 35E2-4-1, *Repair Quality Criteria System for Rapid Runway Repair*.

2-2.2.5 **Existing Pavement Structure.** The configuration of the current pavement layers (e.g., concrete, asphalt over concrete, asphalt, concrete slab).

2-2.2.6 **Time Criteria.** The time allotted to accomplish the repairs before the first aircraft arrival or departure.

2-2.2.7 **Repair Crew Capability.** The repair crew's capacity for the task (e.g., experience, number of repair people, resource availability).

2-2.3 Equipment and Manpower Requirements

Note: Requirements vary by branch of service, type of unit, and the number of repair team members assigned. This listing identifies the types of equipment typically used in ADR.

2-2.3.1 **Army.** Airborne and Air Assault engineer units have the sole capability of repairing airfields to obtain a required MOS during forcible entry operations. They accomplish this mission through the installation of an air-transportable ADR kit. This

expedient pavement repair kit was developed to provide all the materials and non-organic unit equipment required to repair one 7.6-meter (25-foot) diameter crater on either a concrete- or asphalt-surfaced runway. To install this kit, Army units have developed a Light Airfield Repair Package (LARP) that is comprised of organic construction equipment and the ADR kit. **Note:** All equipment in these packages is inserted either by Airborne (heavy drop) or Air Assault (external cargo helicopter loads) techniques. Equipment included in the LARP:

2-2.3.1.1 Airborne LARP. (Requires seven platforms via C-17 or C-130)

- 2.5 cubic yard front-end loader – one each
- SEE (Small Emplacement Excavator) – one each
- Dozer (Deployable Universal Combat Earthmover [DEUCE]) – one each
- Single drum vibratory compactor – one each
- Dump truck – one each
- FAS (Forward Aerial Supply) Box - Includes additional sand grids; water for compaction; 50 repair parts from the Prescribed Load List (PLL) for LARP equipment; petroleum, oil, lubricants (POL) products; gas-powered hand tampers; generator; and assorted miscellaneous hand tools
- ADR kit – two each

2-2.3.1.2 Air Assault LARP. (Requires five lifts via CH-47D Chinook)

- 836G Bobcat with bucket – one each
- 836G Bobcat with sweeper – one each
- JD 450 dozer – one each
- SEE – one each
- ADR kit (with gas-powered hand compactor) – one each

2-2.3.2 Navy/Marine Corps.

2-2.3.2.1 For Navy crater repair units, most of the construction equipment is contained in Advanced Base Functional Component (ABFC) P-36. Typically, ABFC P-36 is provided to an advanced naval airbase located in friendly territory for rapid runway repair (RRR). ABFC P-36 is also included with the ABFCs to be deployed with the Naval Construction Force (NCF) participating in the seizure, construction, and occupation of an advanced naval airbase in enemy territory. The ABFC P-36 RRR component contains the material and equipment required for repairing bomb craters using specified types of earthmoving and earthworking equipment for crater cleanout, backfilling, grading, and compaction. Traffic surface panels, emplaced over the repaired craters, are fabricated from the following:

- Prefabricated panels of AM-2 matting.
- On-site-assembled traffic surface panels prepared from prefabricated bolt-together panels.
- On-site preparation of fiberglass mats.

2-2.3.2.2 Basic earthmoving and compaction equipment is available in MWSS and Force Engineer Support Battalions. Crater repair cover material is configured in an

RRR kit that contains FRP panels and all the necessary ancillary hardware to field two larger or four small mats.

2-2.3.3 Air Force. An RRR equipment set is a standardized set of equipment and vehicles that enables Air Force civil engineers to conduct RRR. There are three fielded RRR sets. The sets are graduated in a building-block manner to provide a designated crater repair capability. For a detailed listing of equipment and vehicles contained in each kit, see Air Force Pamphlet (AFPAM) 10-219, Volume 4, *Rapid Runway Repair Operations*.

2-2.3.3.1 Basic (R-1) Set. This set supports the repair of three bomb craters (15 meters [50 feet] in diameter) with AM-2 matting and/or FFM in four hours. Basic sets are currently in place at most theater locations and contain approximately 59 items of vehicles/construction equipment (e.g., front-end loaders, dump trucks, excavators) and additional supplemental items (flood lights, spall repair material, AM-2, fiberglass mats).

2-2.3.3.2 Supplemental (R-2) Set. This set contains additional vehicles and equipment which are additive to the R-1 set and gives the capability to repair six craters in four hours. The R-2 set contains 26 items of vehicles/construction equipment and supplemental items.

2-2.3.3.3 Supplemental (R-3) Set. This set contains additional vehicles and equipment that, when combined with the R-1 and R-2 sets, enables six repair teams to accomplish 12 crater repairs in four hours. Only a few main operating bases have the R-3 package in-place. The R-3 set contains 18 pieces of vehicles/construction equipment and supplemental items.

2-2.4. Crater Repair Procedures

2-2.4.1 Crushed Stone Crater Repairs

2-2.4.1.1 Different Types

Debris Backfill Crater. Use when subsurface debris is plentiful and suitable for filling the crater. Fill the crater with debris up to 457 millimeters (18 inches) below the surface. Fill the remaining portion of the crater with crushed stone.

Choke Ballast Over Debris Crater. Use when subsurface debris is suitable for fill, but limited. Fill the crater with useable debris. Continue to fill the crater up to 457 millimeters (18 inches) below the surface with ballast rock, and fill the remaining portion of the crater with crushed stone.

Choke Ballast Repair. Use when water is standing in the crater or if subsurface material is unsuitable for filling the crater. Fill the crater with ballast rock up to 457 millimeters (18 inches) below the pavement surface. Fill the remaining portion of the crater with crushed stone.

2-2.4.1.2 **Crushed Stone Repair Procedures.** See Figure 2-1.

(1) Clear debris from around the crater at least 6 meters (20 feet) in all directions to allow identification of the upheaved pavement surface. Identification and removal of all upheaval or damaged pavement is critical. **It cannot be rolled down flush with the existing pavement and left.** The upheaved pavement will eventually break up and create additional problems adjacent to the crater repair.

(2) Perform profile measurement and visual inspection to identify and mark upheaval around the crater.

(3) Remove upheaved pavement using an excavator with bucket or moil point attachment, and the front-end loader. The dozer may also be used, depending on the runway surface.

(4) All debris material in excess of 304 millimeters (12 inches) must be removed or reduced in size. Breaking the pavement into smaller pieces will minimize the potential for voids and settling problems in the future.

(5) Push unusable debris at least 9 meters (30 feet) off the MOS and pile no higher than 0.9 meter (3 feet).

(6) Place backfill material into the crater in accordance with the repair procedure chosen. **Note:** If settling problems are anticipated, placement of membrane fabric between dissimilar backfill materials is recommended.

(7) Fill and compact the crater with crushed stone material, placing it in lifts approximately 152 to 177 millimeters (6 to 7 inches) thick. For C-17 operations, limit the aggregate size to a maximum of 25 millimeters (1 inch) in the top 152 millimeters (6 inches) of the crushed stone repair. Overfill the crater by approximately 76 millimeters (3 inches) above the original pavement surface height. Compact each lift of crushed stone using a **minimum of four passes** of a single drum vibratory roller or **two passes** with a 10-ton vibratory roller. One pass of the roller means traveling across and back in the same lane. If the crushed stone material is placed upon soft subgrade materials, it may be beneficial to separate the material using geomembrane fabric and place the crushed stone material in thicker lifts. In any case, the crushed stone should be compacted with a **minimum of four passes** of a single drum vibratory roller or **two passes** of a 10-ton vibratory roller per each 152 millimeters (6 inches) of thickness. A 457-millimeter (18-inch) crushed stone layer should receive a **minimum of 12 passes** with a single drum vibratory roller or **six passes** with a 10-ton vibratory roller prior to cut for the final grade.

(8) Grade the compacted crushed stone to approximately 25 millimeters (1 inch) above the pavement surface.

(9) Compact the crushed stone using **two passes** of a single drum vibratory roller or **one pass** with a 10-ton vibratory roller. The crushed stone layer should have a

minimum 25 California Bearing Ratio (CBR) to support C-17 operations or a minimum 15 CBR to support C-130 operations.

(10) Perform profile measurement. The repaired crater must not exceed the maximum RQC of ± 19 millimeters (± 0.75 inch). A repair outside this tolerance may still be useable, depending on its location, but will have a much shorter life before requiring additional maintenance to bring it back within this limitation.

(11) The crushed stone repair is complete at this point. Depending on the particular location on the airfield or the type of mission aircraft, it may be left uncovered or may require a FOD cover (see paragraph 2-3).

Figure 2-1. Crushed Stone Repair

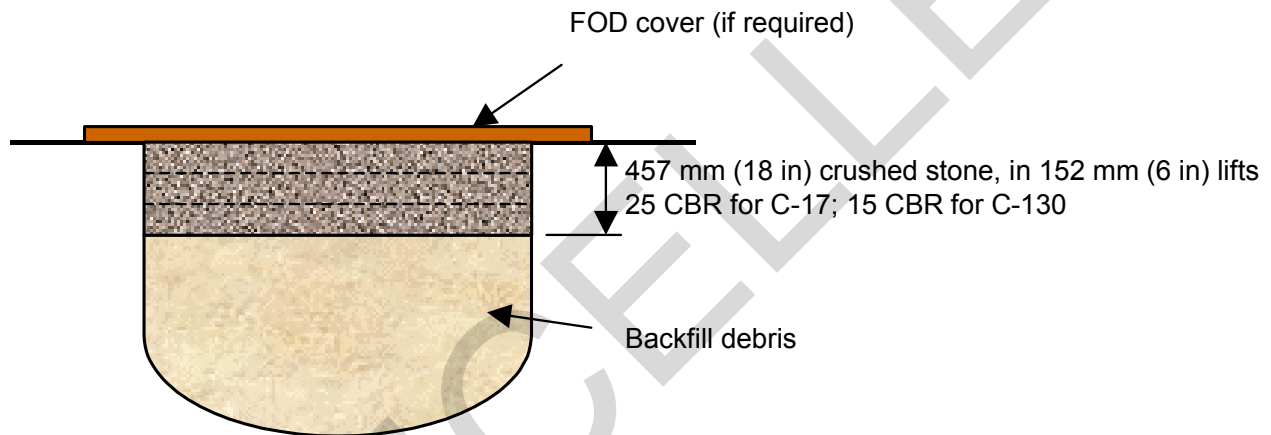

2-2.4.2 Sand-Grid Repair Procedures. See Figure 2-2.

2-2.4.2.1 Clear debris from around the crater at least 6 meters (20 feet) in all directions to allow identification of the upheaved pavement surface. Identification and removal of all upheaval or damaged pavement is critical. **It cannot be rolled down flush with the existing pavement and left.** The upheaved pavement will eventually break up and create additional problems adjacent to the crater repair.

2-2.4.2.2 Perform a profile measurement and visual inspection to identify and mark the upheaval around the crater.

2-2.4.2.3 Break out the upheaved pavement.

2-2.4.2.4 Square the sides to vertical from the original pavement surface down to 406 millimeters (16 inches).

2-2.4.2.5 All debris material in excess of 304 millimeters (12 inches) must be removed or reduced in size.

2-2.4.2.6 Move unusable debris at least 9 meters (30 feet) off the MOS and stockpile no higher than 0.9 meter (3 feet).

2-2.4.2.7 Standing water in the crater must be pumped out, if possible.

2-2.4.2.8 Any reinforcing material protruding from the original pavement must be cut off and removed.

2-2.4.2.9 Clean an area 30 meters (100 feet) from the crater edge for assembling the FOD cover, if possible. The mat assembly site should be no further than 0.8 kilometer (0.5 mile) from the repaired crater. An area approximately 15 meters by 15 meters (50 feet by 50 feet) square is required for assembling the mat.

2-2.4.2.10 Backfill the crater with useable debris or a combination of debris and/or crushed stone. Level this material to 406 millimeters (16 inches) below the original pavement surface. This measurement is critical to ensure a flush repair.

2-2.4.2.11 Compact the debris backfill to a minimum 4 CBR.

2-2.4.2.12 Line the crater with an impervious membrane.

2-2.4.2.13 Place the first layer of sand-grid parallel to the centerline of the runway. Place fill material or short U-shaped pickets in the corners of the grid and along the sides to hold it in place.

2-2.4.2.14 Backfill the sand-grid using cohesionless material, if possible. Overfill the grid by approximately 50 millimeters (2 inches).

2-2.4.2.15 Compact this first layer of fill material. Typically, two passes with a vibratory roller are required for compaction.

2-2.4.2.16 After compaction, all excess material must be struck off level with the top of the sand-grid. This is critical to ensure a flush repair meeting the RQC.

2-2.4.2.17 Place a membrane over the first layer of sand-grid.

2-2.4.2.18 Lay the second layer of sand-grid perpendicular to the first layer and the runway centerline.

2-2.4.2.19 Backfill and overfill the sand-grid using cohesionless material, if possible.

2-2.4.2.20 Compact this layer of backfill. If the two sand-grids were installed and compacted properly the sand-grid should not protrude above the pavement surface.

2-2.4.2.21 Grade off excess material so the repair is flush with the original pavement surface.

2-2.4.2.22 Install and anchor the FRP mat cover. The sand-grid repair must have a FOD cover installed to be operational.

2-2.4.2.23 Verify that the repair does not exceed surface roughness criteria.

Figure 2-2. Sand Grid Repair

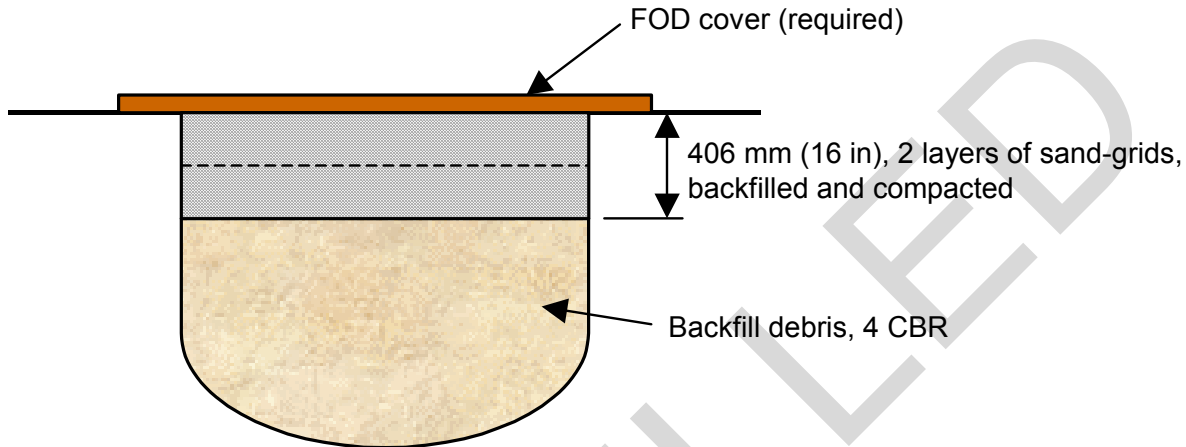

2-2.4.3 **Stone and Grout Repair (Above Freezing Temperatures).** See Figure 2-3.

2-2.4.3.1 This type of repair is considered a *sustainment airfield repair*. It may be used as a replacement for both the crushed stone and sand-grid repairs when additional resources are available. Uniform compaction of backfill material is critical.

2-2.4.3.2 If upgrading a sand grid or crushed stone repair, try to recycle previous repair materials.

2-2.4.3.3 Clear debris from around the crater at least 6 meters (20 feet) in all directions to allow identification of the upheaved pavement surface. Identification and removal of all upheaved or damaged pavement is critical. **It cannot be rolled down flush with the existing pavement and left.** The upheaved pavement will eventually break up and create additional problems adjacent to the crater.

2-2.4.3.4 Perform a profile measurement and visual inspection to identify and mark upheaval around the crater.

2-2.4.3.5 Break out the upheaved pavement.

2-2.4.3.6 Square the sides to vertical from the original pavement surface down to a minimum depth of 406 millimeters (16 inches).

2-2.4.3.7 All debris material in excess of 304 millimeters (12 inches) must be removed or reduced in size.

2-2.4.3.8 Standing water in the crater must be pumped out, if possible.

2-2.4.3.9 Any reinforcing material protruding from the original pavement must be cut off and removed.

2-2.4.3.10 Backfill the crater with useable debris and level to exactly 711 millimeters (28 inches) below the original pavement surface.

2-2.4.3.11 Backfill material must be compacted to a minimum 4 CBR.

2-2.4.3.12 Install a 304-millimeter (12-inch) layer of crushed stone (38 millimeters [1.5 inches] minus) over the backfill material. Place and compact the crushed stone material in lifts approximately 152 millimeters (6 inches) thick. Compact each lift of crushed stone using a **minimum of four passes** of a single drum vibratory roller or **two passes** with a 10-ton vibratory roller per each 152-millimeter (6-inch) lift. One pass of the roller means traveling across and back in the same lane. If the crushed stone material is placed upon soft subgrade materials, it may be beneficial to separate the crushed stone from the backfill with a geomembrane and to place the crushed stone material in thicker lifts. In any case, the crushed stone should be compacted with a **minimum of four passes** of a single drum vibratory roller or **two passes** of a 10-ton vibratory roller per each 152 millimeters (6 inches) of thickness. A 304-millimeter (12-inch) crushed stone layer should receive a **minimum of eight passes** with a single drum vibratory roller, or **four passes** with a 10-ton vibratory roller. This crushed stone material must be compacted to a minimum 25 CBR.

2-2.4.3.13 Place a layer of sand approximately 304 millimeters (12 inches) wide by 25 to 50 millimeters (1 to 2 inches) deep around the entire inside of the crater's lip to prevent seepage of the grout around the edge of the crater.

2-2.4.3.14 Position a layer of impervious membrane material over the entire crushed stone surface.

2-2.4.3.15 Place a 203-millimeter (8-inch) layer of grout material mixed in accordance with Table 2-2 into the crater.

Table 2-2. Stone and Grout Mix Proportions

Grout Mixture	Percentage by Weight	Weight of Additive Per Cubic Yard
Portland cement	67.8	22.3.2 lb (999.4 kg)
Calcium chloride (accelerator)	1	32.67 lb (14.8 kg)
Friction retarder	0.2	6.68 lb (2.9 kg)
Water	31	1004.4 lb (455.6 kg)

Note: This mixture will develop a compressive strength of at least 1500 pounds per square inch (psi) in 24 hours

2-2.4.3.16 Add the calcium chloride accelerator to the grout mix.

2-2.4.3.17 Place a 203-millimeter (8-inch) layer of 76-millimeter (3-inch) stone into the grout mixture, producing a 406-millimeter (16-inch) layer of stone and grout. This stone is worked into the grout by walking a dozer or high-speed tamping foot roller across the repair.

2-2.4.3.18 A vibratory roller is used to percolate the grout up through the stone to the surface.

2-2.4.3.19 The level of the stone and grout mixture should be within 19 millimeters (0.75 inch) of the original pavement surface. Add equal parts of stone and grout until the repair is level with the original pavement surface.

Figure 2-3. Stone and Grout Repair

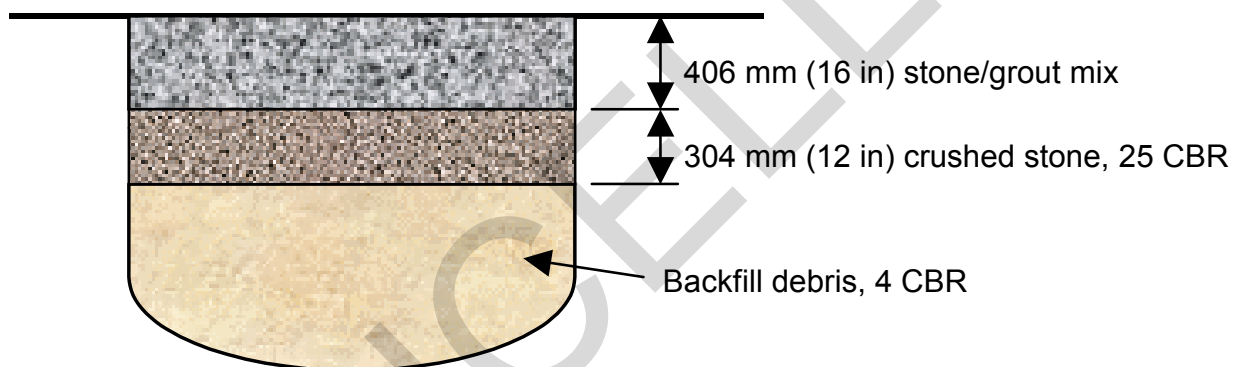

2-2.4.4 Stone and Grout Repair (Below Freezing Temperatures).

2-2.4.4.1 Special consideration must be made when placing the stone and grout mixture in freezing temperatures. There are several methods that can be employed to help ensure successful mission accomplishment.

2-2.4.4.2 Add additional calcium chloride accelerator (up to as much as 3 percent by weight from the normal amount of 1 percent) to the solution of stone and grout to decrease the set time.

2-2.4.4.3 Heat the aggregate; this can be done in a tent surrounding aggregate stockpiles.

2-2.4.4.4 Heat the water. One possible method is to use immersion heaters. It is best to heat both the water and the aggregate, rather than just one. This helps ensure that the extremely cold condition of either component will not offset the heated condition of the other. Do not mix the water and aggregate until the last possible moment.

2-2.4.4.5 Do not uncover the subgrade until immediately before placement to allow

heat to be retained. This necessitates a change in repair priorities since several craters cannot be worked on concurrently (as their subgrades would be left exposed while awaiting grout); rather, one crater is completely repaired before moving on to repair the next.

2-2.4.4.6 Place an insulated blanket over the finished surface. One possible composition of this blanket is a layer of impervious membrane, approximately 254 millimeters (10 inches) of straw or hay, followed by an additional layer of impervious membrane.

2-2.4.5 **Concrete Repair.** See Figure 2-4.

2-2.4.5.1 This type of repair may be used in lieu of or as a replacement for both the crushed stone and sand-grid repairs when additional resources are available. Uniform compaction of backfill material is critical.

2-2.4.5.2 Clear debris from around the crater at least 6 meters (20 feet) in all directions to allow identification of the upheaved pavement surface. Identification and removal of all upheaved or damaged pavement is critical. **It cannot be rolled down flush with the existing pavement surface and left.** The upheaved pavement will eventually break up and create additional problems adjacent to the crater repair.

2-2.4.5.3 Perform a profile measurement and visual inspection to identify and mark upheaval around the crater.

2-2.4.5.4 Square to vertical the sides from the original pavement surface down to a minimum depth of 304 millimeters (12 inches).

2-2.4.5.5 All debris material in excess of 304 millimeters (12 inches) must be removed or reduced in size.

2-2.4.5.6 Standing water in the crater must be pumped out, if possible.

2-2.4.5.7 Any reinforcing material protruding from the original pavement must be cut off and removed.

2-2.4.5.8 Backfill the crater with useable debris and level to exactly 711 millimeters (28 inches) below the original pavement surface to support C-17 operations, or 457 millimeters (18 inches) to support C-130 operations.

2-2.4.5.9 Backfill material must be compacted to a minimum 4 CBR.

2-2.4.5.10 If settling problems are anticipated, a geomembrane fabric is recommended for use between dissimilar backfill and the next layer of material.

2-2.4.5.11 Place a layer of crushed stone (38 millimeters [1.5 inches] minus) over the backfill material. This layer should be 406 millimeters (16 inches) thick to support C-17

operations, or 152 millimeters (6 inches) thick to support C-130 operations. Place the material in lifts approximately 152 millimeters (6 inches) thick. Compact each lift of crushed stone using a **minimum of four passes** of a single drum vibratory roller or **two passes** with a 10-ton vibratory roller. One pass of a roller means traveling across and back in the same lane. If the crushed stone material is placed upon soft subgrade materials, it may be beneficial to separate the crushed stone from the subgrade with a geomembrane and to place the crushed stone material in thicker lifts. In any case, the crushed stone should be compacted with a **minimum of four passes** of a single drum vibratory roller or **two passes** of a 10-ton vibratory roller per each 152 millimeters (6 inches) of thickness. This crushed stone must be compacted to a minimum of 25 CBR.

2-2.4.5.12 The final 304 millimeters (12 inches) is filled with concrete and leveled with the existing pavement surface.

Figure 2-4. Concrete Cap Repair

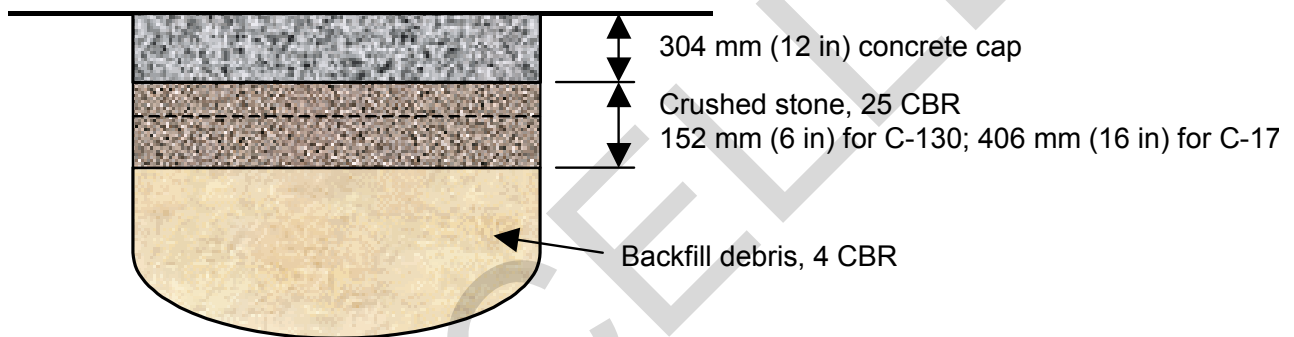

2-2.4.5.13 For craters smaller than 9.1 meters (30 feet) in diameter, screeding can generally be performed by hand. When single craters or overlapping craters form a damaged area greater than 9.1 meters (30 feet) in diameter, a screed method using a concrete pedestal is recommended. See Figure 2-5.

Figure 2-5. Pedestal Designs

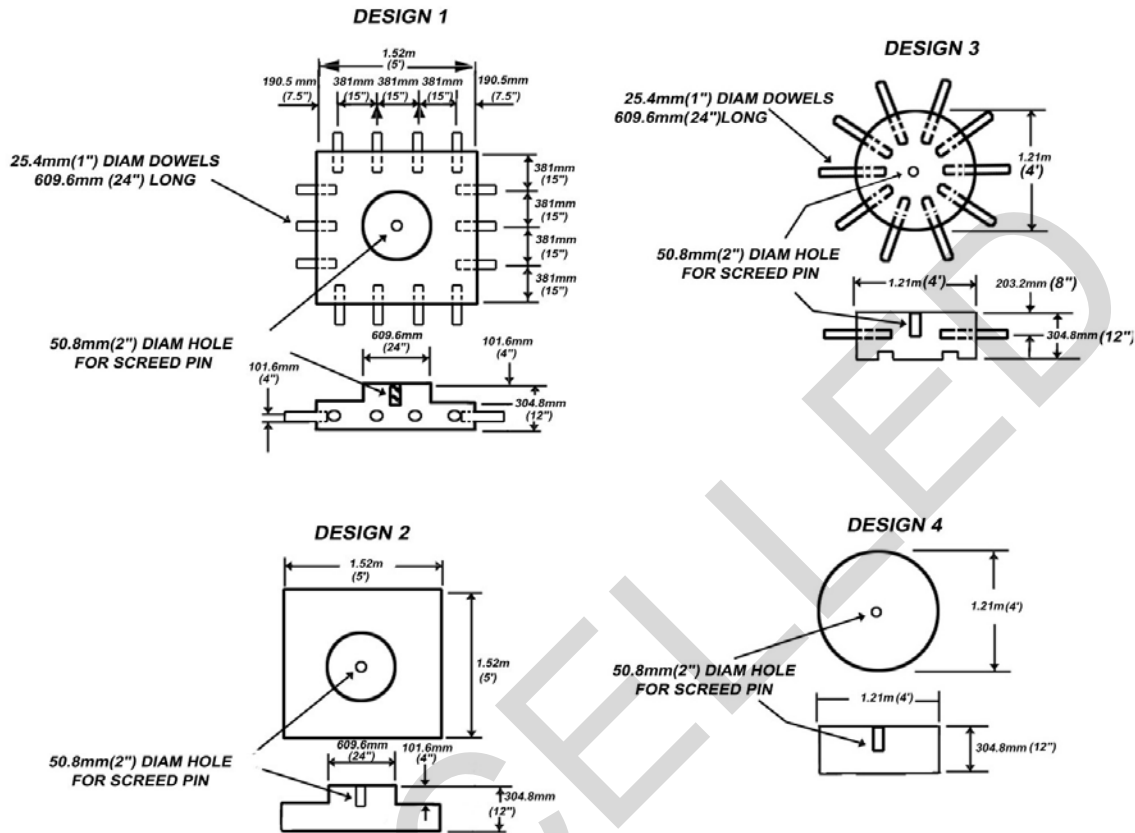

2-2.4.5.14 Prepare the center of the crater so that the surface of the prefabricated concrete pedestal is even with the surface of the runway pavement. This is best accomplished with a string line.

2-2.4.5.15 Secure the screed beam to the pedestal by placing a steel pin through the beam into the slot in the pedestal.

2-2.4.5.16 Clean the edges of the crater and place a starter form in the crater. The starter form is an artificial headboard form that allows the concrete to be rapidly leveled as it is placed into the crater. The starter form is removed from the crater as soon as the placement is completed. Experience has shown that load transfer devices (such as dowels) are not needed to permit better bonding to the existing runway.

2-2.4.5.17 It is critical to ensure a homogeneous placement of the concrete cap. At least three concrete ready-mix or concrete-mobile modules should be pre-positioned around the crater to allow an initial steady placement of concrete into the crater.

2-2.4.5.18 Finish the surface until it is smooth and level with the surrounding pavement. An accelerator must be added to quicken the curing time. The concrete must be allowed to cure at least 24 hours before trafficking fighter aircraft.

2-3 FOD COVERS

2-3.1 Army FOD Cover Assembly Procedures

2-3.1.1 This FOD cover is referred to as an FRP mat. The Army ADR kit contains FRP panels in three sizes. There are four full-size panels (5.49 meters by 2.01 meters by 12.7 millimeters thick [18 feet by 6.6 feet by 0.5 inch thick]); two right-half panels (2.62 meters by 2.01 meters by 12.7 millimeters thick [8.6 feet by 6.6 feet by 0.5 inch thick]); and two left-half panels (2.83 meters by 2.01 meters by 12.7 millimeters thick [9.3 feet by 6.6 feet by 0.5 inch thick]). When assembled, this cover will cap one crater 7.6 meters (25 feet) in diameter.

2-3.1.2 Assembled mat dimensions are 8.11 meters by 8.11 meters (26.6 feet by 26.6 feet). On one side and on one end of the mat are holes 63.5 millimeters (2.5 inches) in diameter for inserting anchor bushings or connector bushings.

2-3.1.3 Position the panels on a smooth level surface for assembly. Assemble in a brickwork-type pattern.

2-3.1.4 Install and tighten panel-connecting bolts as each row of panels is aligned.

2-3.1.5 Pull the assembled mat into position over the crater. The mat must overlap the crater edges by at least 304 millimeters (12 inches) on each side.

2-3.1.6 Secure the mat on the leading and trailing edge or perpendicular to the direction of flight. Drill pilot holes for the anchor bolts.

2-3.1.6.1 Concrete anchoring uses a Wej-it[®] anchor bolt. There are two sizes of Wej-it[®] bolts in the kit: the bolt 177.8 millimeters long by 15.9 millimeters in diameter (7 inches long by 0.625 inch in diameter) is installed using rotary hammer tools; the bolt 177.8 millimeters long by 19.1 millimeters in diameter (7 inches long by 0.75 inch in diameter) is placed with the SEE (for this bolt, a pilot hole must be drilled 203 millimeters [8 inches] deep with a 19.1-millimeter [0.75-inch] bit).

2-3.1.6.2 Asphalt anchoring consists of a screw spike style F head. This screw is 152.4 millimeters long by 19.1 millimeters in diameter (6 inches long by 0.75 inch in diameter). A pilot hole must be drilled 177 millimeters by 15.9 millimeters in diameter (7 inches deep by 0.625 inch in diameter).

2-3.2 **Air Force FFM.** Air Force FFM is manufactured by Rapid Mat US Inc., 3112 M Street, Washington, DC, 20007, phone (202) 295-9097. Mat manufacturing takes place at 8478 Old Monroe Road, Bastrop, Louisiana, 71220-5646.

2-3.2.1 The FFM is air-transportable, can be moved easily by vehicles, can be positioned at greater distances from airfield pavement surfaces, and can be stored indoors out of the elements.

2-3.2.2 A standard FFM weighs about 1360 kilograms (3,000 pounds) and consists of nine fiberglass panels, each 1.83 meters wide by 9.14 meters long by 12.7 millimeters thick (6 feet wide by 30 feet long by 0.5 inch thick). Elastomer hinges 76.2 millimeters (3 inches) wide connect the panels. When folded, these mats are 1.83 meters wide by 9.14 meters long and 203 to 254 millimeters thick (6 feet wide by 30 feet long and 8 to 10 inches thick).

2-3.2.3 This repair system also includes joining panels and two support mat kits. The joining panels come in 7.32-meter and 9.14-meter (24-foot and 30-foot) lengths. One of each size is needed to connect two 9.14-meter by 16.46-meter (30-foot by 54-foot) mats. The resulting 16.46-meter by 18.29-meter (54-foot by 60-foot) mat is the normal size suitable for most crater repairs. If larger FOD covers are required, additional mats may be spliced together.

2-3.2.4 There are two types of support mat kits for the FFM. Mat Kit A contains all the necessary tools and hardware required to assemble, install, and maintain the system. Mat Kit B contains the anchor bolts required to attach the mat to the pavement surface.

2-3.2.5 The mat assembly area can be any area near the crater repair. This area must be cleared of all debris and swept. It must be large enough to accommodate the unfolding of both mats, allow equipment operations around the mat, and not interfere with crater preparations. This area should be approximately 30.4 meters by 30.4 meters (100 feet by 100 feet) square, and located a minimum of 30.4 meters (100 feet) from the crater and off the MAOS.

2-3.2.6 Mats are placed end-to-end about 1.2 meters (4 feet) apart, with the first panel up and positioned such that both mats unfold in the same direction.

2-3.2.7 Unfold the mats in preparation for being joined together. The top panel of the mat is attached to a tow vehicle with a nylon strap. A crew of four people, or a forklift positioned on the opposite side of the mat, lifting each successive panel as the mat is being pulled open, speeds the unfolding process.

2-3.2.8 Resin flaking at the mat hinge can occur and create a FOD problem with mats that were procured from the initial manufacturing programs. To eliminate this problem, make one pass with a vibratory roller down each hinge, followed with a sweeper. This operation normally loosens and removes the flaking material from the hinges.

2-3.2.9 Join the mats together so they are aligned, the 9.14-meter (30-foot) edges are even, and the 16.46-meter (54-foot) edges are roughly parallel with each other.

2-3.2.10 Lift one end of the 16.46-meter (54-foot) edge and slip either the 7.32-meter (24-foot) or the 9.14-meter (30-foot) section of joining panel underneath the raised edge. Align the holes in the mat with the joining panel bushing holes and lower the mat.

2-3.2.11 Install the top joining bushings and tighten by hand. This process is repeated

at the other end of the 16.46-meter (54-foot) edge of the same mat using the remaining joining panel. Hand-tighten these bushings; final tightening will be accomplished later.

2-3.2.12 The second mat is then towed over to the first mat with joining panel attached. One of the holes near the end of the second mat is aligned with its counterpart on the joining panel and a top joining bushing is installed.

2-3.2.13 This end connection acts as a pivot point when the second mat is moved into position so all the remaining holes on the joining panel are in alignment. Install the remaining top bushing and tighten the entire second mat bushing with an impact wrench.

2-3.2.14 Revert to the first top joining bushings and tighten them with the impact wrench. All joining bushings should be tightened and the joined mats are now ready to be towed over the repaired crater.

2-3.2.15 Before any towing operation can commence, the area between the mat assembly area and the repaired crater must be completely swept. Any debris that is picked up under the mat as it is being towed could damage the matting and affect the smoothness of the repair.

2-3.2.16 When the width of the MAOS permits, the mat should be towed parallel to and next to the crater. Align the joining panel with the center of the crater. Use a front-end loader or similar vehicle to tow the mat over the crater with the hinges perpendicular to the tow direction. Position the mat so the hinges are parallel to the direction of the MAOS traffic. The mat should not be more than 5 degrees off parallel.

2-3.2.17 With the mat in position over the crater, it must be anchored in place. Techniques for anchoring the FFM will depend on the type of pavement surface. The FFMs are predrilled for anchoring bolts. All three anchoring techniques use a 101.6-millimeter (4-inch) bushing through which the bolt passes to hold down the mat.

2-3.2.17.1 **Concrete Pavements.** The concrete anchor is normally a rock bolt that is 127 to 152.4 millimeters long and 15.9 to 19.1 millimeters in diameter (5 to 6 inches long and 0.625 to 0.75 inch in diameter). At each predrilled hole in the leading and trailing edges of the mat, drill a hole into the pavement corresponding to the diameter of the bolt being used. Position an anchor bushing in the predrilled hole as a guide for centering the drill bit. The depth of the hole must be at least 12 millimeters (0.5 inch) longer than the length of the bolt. Clean out the drill cutting with compressed air and insert the bolt through the bushing. Stand on the mat and bushings and tighten the bolt with an impact wrench.

2-3.2.17.2 **Asphalt-overlaid Concrete Pavements.** Asphalt-overlaid concrete usually entails using a rock bolt that is 241.3 millimeters long and 15.9 to 19.1 millimeters in diameter (9.5 inches long and 0.625 to 0.75 inch in diameter). The installation procedure is the same as those for all-concrete pavements. The key factor in this installation is to ensure the bolt has been set deep enough into the concrete layer for a

firm grip.

2-3.2.17.3 **Asphalt Pavements.** Anchoring in asphalt pavement requires a 241.3-millimeter (9.5-inch) bolt and polymer. A hole 254 millimeters deep and 38 millimeters in diameter (10 inches deep and 1.5 inches in diameter) is drilled at the center of each predrilled mat hole. A two-part resin polymer is mixed and poured into each hole to about 38 millimeters (0.5 inch) below the surface of the pavement. An anchor bushing and bolt are immediately placed into each hole and pressed firmly (standing on the bolt and bushing) against the mat. The polymer will harden in about three minutes. Unless extra people are available, there may not be time to drill all the holes before beginning to pour the polymer. Drilling and setting the bolts are usually accomplished concurrently.

2-4 **AM-2 ALUMINUM MAT**

2-4.1 **Navy/Marine Corps.** AM-2 matting is used for the construction of complete runways, taxiways, parking areas, and vertical takeoff and landing (VTOL) pads in accordance with NAWCADLKE-MISC-48J200-0011 and NAVAIR 51-60A-1. Assembling AM-2 to accommodate these various applications requires a number of special pieces (e.g., connectors, keylocks, spacer mats, adapters) not normally used for an AM-2 patch. Many applications require anchoring or staking to stop vertical and horizontal movement. Anchors and stakes must be installed and tested in accordance with NAWCADLKE-MISC-48J200-0011 and NAVAIR 51-60A-1.

2-4.2 **Air Force.**

2-4.2.1 **Purpose.** The extruded aluminum alloy matting designated as AM-2 has been in the Air Force inventory for almost 40 years. Once the mainstay of rapid runway crater repairs, it has been mostly relegated to a secondary use for taxiway repairs and parking apron expansion. It does, however, represent an option for runway repairs if other methods cannot be used. AM-2 mat repair must meet the RQC for its location on the runway.

2-4.2.2 **Limitations.** AM-2 mat repair kits are generally acceptable for fighter aircraft and C-130s but inadequate for jet cargo aircraft landing strips. This limitation is due to the inadequate anchoring system, narrow patch width (16.5 meters wide by 23.6 meters long [54 feet wide by 77.5 feet long]), and susceptibility to jet blast from outboard engines. AM-2 mats can be used to repair taxiways and aprons if braking and tight turns are limited on the mat. Adequate drainage of the base and subbase layers is important. Excess moisture in these layers will cause a reduction in the load-bearing capacity of the subsurface material, and subsequently mat failure.

2-4.2.3 **Factors Affecting AM-2 Life.** AM-2 has proven over the years to be the best metal surface matting in the DOD inventory; however, it is not the panacea for all expedient and theater of operations airfield problems. Its life expectancy is directly proportional to the quality of the base, subbase, and the amount of traffic. Weather also seriously affects its service and life. Where there is heavy rainfall, water collects under

the matting unless there is adequate drainage. When this happens, water eventually pumps through the matting and erodes the base.

2-4.2.4 Base Quality. Experience has shown that AM-2 performs best on a layer of clean, well-graded, compacted crushed stone subbase. The amount of maintenance required to care for this mat varies depending on the following factors: soil condition; quality of the base and subbase; type of membrane used; weather; and the impact of aircraft traffic.

2-4.2.5 Plastic Membrane. On a base of inferior silt or clay, AM-2 matting gives much better service if a geomembrane is placed beneath the AM-2 surface. Although the initial cost of geomembrane is high, it can be cost-effective for long-term operations.

2-4.2.6 Traffic. The most important step in prolonging the life of AM-2 that is laid directly on a silt or clay base is to keep aircraft and vehicular traffic to an absolute minimum during and following periods of inclement weather. This will allow water under the surface to drain completely from the base; otherwise, the impact of the traffic will pump the water into the base and destroy it.

2-4.2.7 Precautions in Repairing/Laying AM-2 Panels. Remember that AM-2 can only be laid in one direction: right to left facing the direction in which the mat is placed. Experience with AM-2 has shown the following:

2-4.2.7.1 It requires 200 to 300 percent more effort to place/install AM-2 than it does to remove it.

2-4.2.7.2 The more perfect the finished grade of the base course, the easier it is to lay AM-2.

2-4.2.7.3 Six hours is about the maximum time a person can sustain production when handling AM-2. In the tropics, people can handle more matting in a six-hour night shift than in a 10-hour shift in the heat of the day.

2-4.2.7.4 Use a string line along the edge for proper alignment.

2-4.2.7.5 To maintain proper alignment, always use a locking bar as a spacer behind the last joint.

2-4.2.7.6 Never crowd the bundles of stacked panels next to the panels being laid, as this may require moving the stacked bundles twice.

2-4.2.8 General AM-2 Assembly Guidelines

2-4.2.8.1 AM-2 matting can be assembled in place (taxiway and aprons) or assembled away from the repair and towed into position (crater repair). Mats assembled in place usually don't require all the ancillary pieces, like starter key lock, mandrels, or towing tubes that a mat to be towed into place will require to keep it from separating during

towing.

2-4.2.8.2 AM-2 can be assembled as a crater cover that is usually 16.5 meters wide by 23.6 meters long (54 feet wide by 77.5 feet long), or as a FOD cover, to extend a parking ramp whose dimensions are limited only by the amount of AM-2 available. The assembly procedures are similar; however, for specific instructions on how to assemble a towed patch, see AFPAM 10-219.

2-4.2.8.3 Assemble the matting from right to left in the direction in which the mat will be placed. You can assemble this matting using all full mats (3.65 meters [12 feet]) or a combination of full and half (1.83 meters [6 feet]) mats. A standard bundle of AM-2 contains 11 full-length mats and two half-length mats; both will be described since every piece of mat will be needed.

2-4.2.8.4 Position the first piece of full mat so that the left end of the mat has the prongs facing up. Position the second full mat so that the right end of the mat prongs is facing down. The prongs of both mats should join together. To increase stability and lock the mats together, insert a flat locking bar into the rectangular slot formed where the end prongs are joined. Continue this process across the full width of the assembly. The only exception is the last piece of mat; use a half mat instead of a full mat.

2-4.2.8.5 The second row is placed similar to the first except it is started with a half mat first. Before placing each mat into position, make a quick check of the prongs for debris. Use a broom or brush to remove dirt and stone that might prevent the mat from joining together. As each mat is positioned, install the locking bars.

2-4.2.8.6 The mats are designed with a loose fit that allows for expansion; therefore, it is possible to have a row of mats installed so misaligned as to prevent the proper engagement of follow-on rows. Using locking bars as temporary spacers between the rows can normally prevent this condition. Place a locking bar on edge where the ends of two mats join and at the row ends. After three or four rows have been laid using locking bar spacers, remove the spacers further away and use them on the row that has just been laid. These locking bar spacers are commonly referred to as "T" spacers.

2-4.2.8.7 Use extreme caution in adjusting the mat; always place a wooden block against the mat edge. Strike the wooden block and not the mat. Sledgehammer blows against the edge of the mat can deform the edge enough to make it impossible to connect the next row of mats.

2-4.2.8.8 Ramps have been developed to ease the transition from the pavement surface onto the mat. Start at the right corner of the assembled mat to connect the first ramp. Place the next ramp so that the holes in the overlapping plate are aligned with the threaded inserts on the ramp just installed. Fasten with flat-head screws coated with anti-seize compound. Use locking bar spacers between the mat and the ramp to keep it properly aligned.

2-4.2.8.9 After all ramps are placed and screwed together, use the ramps as a template

or guide to drill holes in the pavement. Hole depth and size is dependent on the type of anchor bolt being used.

2-5 REPAIR EVALUATION METHODS

2-5.1 **Acceptance Criteria.** Crater repairs must be evaluated before acceptance for aircraft operations. The following areas should be considered:

2-5.1.1 **Repair Compaction.** The strength of the backfill, debris, or subgrade materials must be verified. Depending upon the repair method used, the thickness and strengths of all surface and/or base course materials must also be verified. The soil structure should be tested using a dynamic cone penetrometer (DCP) to determine CBRs of each layer. These tests must be accomplished before placing the FOD covers, AM-2 matting, stone and grout, asphalt, concrete, or other surface materials that would prevent the use of the DCP.

2-5.1.2 **Surface Roughness.** The final grade of the repair must be checked using line-of-sight profile measurement stanchions, upheaval posts, or string lines to ensure the repair meets surface roughness criteria contained in T.O. 35E2-4-1. Procedures are described in T.O. 35E2-5-1, *Crushed-Stone Crater Repair and Line-Of-Sight Profile Measurement for Rapid Runway Repair*. In the case of a crushed stone repair without a FOD cover, the repair surface should be checked for loose aggregate or potential FOD.

2-5.1.3 FOD Covers

2-5.1.3.1 FOD covers should be no more than 5 degrees off parallel with the runway centerline.

2-5.1.3.2 Check connection bolts and verify that all connections between panels are tight and secure.

2-5.1.3.3 Check anchor bolts and verify that all bolts are secure and that the FOD cover is held snugly against the pavement surface. In taxiway and apron applications, the leading and trailing edges of the FOD cover must be anchored. The side edges must also be anchored if the cover is located in an area where aircraft will be required to turn.

2-5.1.4 **Setting/Curing.** If the repairs are capped with concrete, stone and grout, or rapid-set materials, verify that the surface material has set and that adequate cure time is allowed prior to aircraft operations.

2-5.1.5 **Clean-up.** For all repair methods, verify that the repair and adjacent area is cleared of any excess repair materials.

2-5.2 Airfield Certification

2-5.2.1 The on-site engineer responsible for the repair will certify that the repair was

accomplished in accordance with the procedures in this ETL.

2-5.2.2 The repair procedures will be documented on an ADR log similar to the one provided in Attachment 1. This form will then be updated to reflect subsequent aircraft traffic and required maintenance throughout the history of the repair. If another team replaces the initial repair team, this form should be given to the follow-on team. This information will be useful in planning or performing any further maintenance and/or upgrade of the repairs.

2-5.2.3 Upon completion of repairs, the status of the airfield/repairs should be provided to the airfield manager or other individual authorized to monitor and control on-site aircraft operations. This individual can then issue a NOTAM to change the airfield status. If questions arise, the following contacts may be useful:

2-5.2.3.1 **Navy/Marine Corps Operations.** Contact the Marine Corps Airfield Service Officer. All AM-2 mat airfield installations on which aircraft operate under their own power require certification in accordance with NAWCADLKE-MISC-48J200-0011. AM-2 mat expanses on which aircraft are **towed only** do not require certification. The inspector must use the instructions and procedures in NAWCADLKE-MISC-48J200-0011 to ensure the structural and functional integrity of AM-2 mat and accessories. Annual certifications will be accomplished after the initial certification.

2-5.2.3.2 **Air Force Operations**

For questions regarding the suitability of paved airfields, contact Headquarters Air Mobility Command, Airfield Analysis (HQ AMC/DOVS), DSN 779-3112.

For questions regarding the suitability of semi-prepared airfields, contact Headquarters Air Mobility Command, Directorate of Operations (HQ AMC/DOK), DSN 779-3727.

If information on a particular airfield is not available from HQ AMC/DOVS or HQ AMC/DOK, or if a site survey is required, contact Headquarters Air Mobility Command, Tanker Airlift Control Center, Mission Support Cell (HQ AMC TACC/XOPM), DSN 779-4015, who tasks Tanker Airlift Control Elements (TALCE) and/or Air Mobility Operations Groups (AMOG) to perform suitability surveys of paved airfields; or Headquarters Air Force Special Operations Command, Operations and Training (HQ AFSOC/DOO), DSN 579-4073, who tasks Special Tactics Teams (STT) through the 720th Special Tactics Group, Operations and Training (STG/DOO), DSN 579-4250, to perform semi-prepared airfield or landing zone surveys.

2-6 **PERMANENT REPAIRS.** Permanent airfield pavement repairs should be accomplished in accordance with the design standards contained in UFC 3-260-02 and with procedures contained in TM 5-822-7, *Standard Practice for Concrete Pavements*, and TM 5-822-8, *Bituminous Pavements Standard Practice*, for rigid and flexible pavements, respectively.

GLOSSARY

Acronyms and Abbreviations

720 STG/DOO — 720th Special Tactics Group, Operations and Training

ABFC — Advanced Base Functional Component

ADR — airfield damage repair

AFJPAM — Air Force Joint Pamphlet

AFM — Air Force Manual

AFMAN — Air Force Manual

AFPAM — Air Force Pamphlet

AFPD — Air Force Policy Directive

AMOG — Air Mobility Operations Group

CBR — California Bearing Ratio

COTS — commercial-off-the-shelf

DCP — dynamic cone penetrometer

DEUCE — Deployable Universal Combat Earthmover

DOD — Department of Defense

ETL — Engineering Technical Letter

FAS — Forward Aerial Supply

FFM — folded fiberglass mat

FLIP — Flight Information Publication

FM — Field Manual

FOD — foreign object damage

FRP — fiberglass reinforced plastic

HQ AFCESA/CES — Headquarters Air Force Civil Engineer Support Agency, Technical Support Directorate

HQ AFCESA/CEC — Headquarters Air Force Civil Engineer Support Agency, Civil Engineering Division

HQ AFSOC/DOO — Headquarters Air Force Special Operations Command, Operations and Training

HQ AMC TACC/XOPM — Headquarters Air Mobility Command, Tanker Airlift Control Center, Mission Support Cell

HQ AMC/DOK — Headquarters Air Mobility Command, Directorate of Operations

HQ AMC/DOVS — Headquarters Air Mobility Command, Airfield Analysis

in— inch

kg — kilogram

LARP — Light Airfield Repair Package

lb — pound

MAOS — minimum airfield operating surface

mm— millimeter

MOS — minimum operating strip

MWSG — Marine Wing Support Group

MWSS — Marine Wing Support Squadron

NAVAIRINST — Naval Air Systems Command Instruction

NAVAIRMAN — Naval Air Systems Command Manual

NAVFAC — Naval Facilities Engineering Command

NAWCADLKE — Naval Air Warfare Center Aircraft Division Lakehurst

NCF — Naval Construction Force

NMCB — Navy Mobile Construction Battalions

NOTAM — Notice to Airman

PLL — Prescribed Load List

POL — petroleum, oil, lubricants

Prime BEEF — Priority Improved Management Effort - Base Engineer Emergency Force

psi — pound per square inch

RED HORSE — Rapid Engineers Deployable - Heavy Operations Repair Squadron Engineers

RQC— Repair Quality Criteria

RRR— rapid runway repair

SEE — Small Emplacement Excavator

STT — Special Tactics Team

T.O. — Technical Order

TALCE — Tanker Airlift Control Element

TC — Training Circular

UFC — Unified Facilities Criteria

USACE — US Army Corps of Engineers

VTOL — vertical takeoff and landing

Terms

Actual crater diameter: Opening in the airfield surface after all the debris and upheaved surface have been removed. Also measured from lip-to-lip, and in most cases is significantly larger than the apparent diameter.

Airfield: An airfield may be captured, constructed, or provided by the host nation, and may consist of any suitable aircraft operating surface.

Apparent crater diameter: Opening in the airfield surface that can be seen before any work is accomplished on the crater; measured from upheaval lip-to-lip.

Camouflet: Craters with relatively small apparent diameters but deep penetration and subsurface voids. Penetration-type projectiles with time-delay fuses normally cause camouflets.

Expedient airfield repair: Provides an accessible and functional MAOS that will sustain 100 C-17 passes with a gross weight of 227,707 kilograms (502 kips), or 100 C-130 passes with a gross weight of 79,380 kilograms (175 kips), or 100 passes of a particular aircraft at its projected mission weight if other than the C-17 or C-130, or the number of passes required to support the initial surge mission aircraft.

Large crater: Damage that penetrates into the base course from the airfield surface. Large craters have an apparent diameter that exceeds 6 meters (20 feet).

Minimum airfield operating surface (MAOS): The minimum surface on an airfield that is essential for the movement of aircraft. It includes the aircraft dispersal areas or parking aprons, the runways, and the taxiways between them.

Minimum operating strip (MOS): The smallest amount of area that must be repaired to launch and recover aircraft. Selection of the MOS will depend upon mission requirements, taxi access, resources available, and estimated time to repair. The length of the MOS will depend on the take-off or landing distance of the mission aircraft, whichever is greater. For fighter aircraft, the typically accepted dimensions are 1524 meters long by 15.2 meters wide (5,000 feet long by 50 feet wide). For the C-130 Hercules, the dimensions are 1067 meters long by 18.3 meters wide (3,500 feet long by 60 feet wide). For the C-17 Globemaster III, the dimensions are at least 18.3 meters long (but may be longer depending upon altitude, surface type, and runway condition rating of the airfield; see ETL 98-5, *C-130 and C-17 Contingency and Training Airfield Dimensional Criteria*) and 27.4 meters (90 feet) wide.

Note to Airman (NOTAM): A NOTAM is issued for inclusion in DOD Flight Information

Publications (FLIP) to alert aircrews of the establishment and condition of, or changes to, airfield facilities. This would include any restrictions or limitations placed upon airfield operations due to airfield damage.

Permanent airfield repair: This repair increases the MAOS to sustain 50,000 or more C-17 passes with a gross weight of 263,008 kilograms (580 kips), or 50,000 C-130 passes with a gross weight of 79,380 kilograms (175 kips), or to support a service-defined airfield design type, depending upon mission aircraft, in accordance with UFC 3-260-02, *Pavement Design for Airfields*.

Small crater: Damage that penetrates into the base course from the airfield surface. Small craters have an apparent diameter of 6 meters (20 feet) or less.

Spall field: Cluster of spalls within an area requiring repair. May include from 10 to several hundred spalls, depending on the munitions used.

Spall: Pavement damage that does not penetrate through the pavement surface to the underlying soil layers. A spall damage area could be up to 1.5 meters (5 feet) in diameter.

Sustainment airfield repair: Maintains or increases the MAOS to support the operation of 5,000 C-17 passes with a gross weight of 227,707 kilograms (502 kips), or 5,000 C-130 passes with a gross weight of 79,380 kilograms (175 kips), or the number of passes required to support mission aircraft at the projected mission weights throughout the anticipated operation, if other than the C-17 or C-130.

APPENDIX A

REFERENCES

GOVERNMENT PUBLICATIONS:

1. Joint Publications

Unified Facilities Criteria (UFC) 3-260-02, *Pavement Design for Airfields*

UFC 3-250-03, *Standard Practice Manual for Flexible Pavements*

Army Field Manual (FM) 5-430-00-1, Air Force Joint Pamphlet (AFJPAM) 32-8013, Volume I, *Planning and Design of Roads, Airfields, and Heliports in the Theater of Operations – Road Design*

FM 5-430-00-2, AFJPAM 32-80-13, Volume II, *Planning and Design of Roads, Airfields, and Heliports in the Theater of Operations – Airfield and Heliport Design*

<http://airfielddamagerepair.com/> (This joint service Web site is currently under development.)

2. Air Force

Air Force Pamphlet (AFPAM) 10-219, Volume 4, *Rapid Runway Repair Operations*

Technical Order (T.O.) 35E2-4-1, *Repair Quality Criteria System for Rapid Runway Repair*

T.O. 35E2-5-1, *Crushed-Stone Crater Repair and Line-Of-Sight Profile Measurement for Rapid Runway Repair*

Engineering Technical Letter (ETL) 98-5, *C-130 and C-17 Contingency and Training Airfield Dimensional Criteria*

T.O. 35E2-3-1, *Folded Fiberglass Mats for Rapid Runway Repair*

ETL 97-9, *Criteria and Guidance for C-17 Contingency and Training Operations on Semi-Prepared Airfields*

Air Force publications are available online at <http://www.e-publishing.af.mil/>

Air Force ETLs are available online at <http://www.afcesa.af.mil/Publications/ETLs/default.html> and (for CCB subscribers) <http://www.ccb.org/html/home.html>

Air Force T.O.'s are available online at (<https://toindex-s.robins.af.mil/toindex/>)

Headquarters Air Force Civil Engineer Support Agency, Civil Engineering Division
(HQ AFCESA/CESC), Pavements Program:

<http://www.afcesa.af.mil/Directorate/CES/Civil/Pavements/Pavements.htm>

3. Army

Army Technical Manual (TM) 5-822-7, Air Force Manual (AFM) 88-6, Chapter 8,
Standard Practice for Concrete Pavements

TM 5-822-8, AFM 88-6, Chapter 9, *Bituminous Pavements Standard Practice*

Army Training Circular (TC) 5-340, *Air Base Damage Repair (Pavement Repair)*

Army CE Manuals: <http://www.usace.army.mil/inet/usace-docs/armytm/>

Engineering Research and Development Center, Geotechnical and Structures
Laboratory, Airfields and Pavements Branch: <http://pavement.wes.army.mil/>

4. Navy/Marine Corps

Naval Air Systems Command (NAVAIR) 51-60A-1, Technical Manual, Handbook,
*AM-2 Airfield landing Mats and Accessories; Installation, Maintenance,
Repackaging, & Illustrated Parts Breakdown*

Naval Air Systems Command Instruction (NAVAIRINST) 13800.12B, *Certification of
Expeditionary Airfield AM-2 Mat Installations, Aircraft Recovery Equipment,
Visual/Optical Landing Aids, and Marking/Lighting Systems*

Naval Air Warfare Center Aircraft Division Lakehurst (NAWCADLKE)-MISC-48J200-
0011, *Expeditionary Airfield AM-2 Mat Certification Requirements*

Naval Facilities Command (NAVFAC) P-80, *Facility Planning Criteria for Navy and
Marine Corps Shore Installations*

NAVFAC P80.3, *Facility Planning Factor Criteria for Navy and Marine Corps Shore
Installations, Appendix E, Airfield Safety Clearances*

Naval Air Systems Command Manual (NAVAIRMAN) 48J200-00-21, *Subgrade
Requirements for Expeditionary Airfields*

NAVAIR 00-80T-115, *Expeditionary Airfield NATOPS Manual*

Navy/Marine Corps Runway Crater Repair Handbook

NAWCADLKE MISC-48J200-0021, *Subgrade Requirements for Expeditionary
Airfields*

NAWCADLKE-DDR-48J200-0038, *In-Plane Bow Repair Method*

Navy/Marine Corps Web site – Under development

AM-2 Mat Repair Procedure # 1, Removal Rubber Buildup from AM-2 Utilizing the Sodium Bicarbonate Blasting Process.

CANCELLED

APPENDIX B

Airfield Damage Repair Log		
Airfield Name/Location:	Repair Location(s):	
Date of Repairs:	Repair Team:	
Repair Method: <input type="checkbox"/> Crushed Stone <input type="checkbox"/> Sand Grid <input type="checkbox"/> Stone and Grout <input type="checkbox"/> AM-2 <input type="checkbox"/> Rapid Set Material, _____ <input type="checkbox"/> Concrete Cap <input type="checkbox"/> Asphalt <input type="checkbox"/> Stabilized Surface, Type: _____ <input type="checkbox"/> Other (<i>describe in Comments</i>)	FOD Cover: <input type="checkbox"/> FRP (Army) <input type="checkbox"/> FRP (Navy) <input type="checkbox"/> FFM (Air Force) <input type="checkbox"/> None <input type="checkbox"/> Other (<i>describe in Comments</i>)	Amount: _____
Repair Criteria: <input type="checkbox"/> Expedient <input type="checkbox"/> Sustainment <input type="checkbox"/> Permanent	Mission Aircraft: <input type="checkbox"/> C-17 <input type="checkbox"/> C-130 <input type="checkbox"/> Other, _____	
Comments (<i>type and quality of repair materials, CBR of compacted materials, deviations from approved repair procedures, problems encountered, repair performance to-date, etc</i>):		
Aircraft Traffic (<i>if available</i>):		
Subsequent Maintenance:		
Certification:		
Engineer on Site:	Organization:	Date: