



**US Army Corps  
of Engineers®**

# ENGINEERING AND CONSTRUCTION BULLETIN

No. 2008- 11

Issuing Office: CECW-CE

Issued: 27 Mar 2008

**Subject:** Marking of Army Airfield-Heliport Operational and Maintenance Facilities

**Applicability:** Directive

1. References:

- a. UFC 3-260-05A, Marking of Army Airfield-Heliport Operational and Maintenance Facilities, 16 January 2004.
- b. AFI 32-1042, Standards for Airport Markings, 27 October 2005
- c. AF ETL 04-02, Standard Airfield Pavement Marking Schemes, 19 July 2004

2. This ECB provides current criteria for marking U.S. Army airfield pavements, including additional criteria and changes to UFC 3-260-05A. Chapter 2 of UFC 3-260-05A shall be used for marking all U.S. Army runways with the following exceptions: Threshold markings shall be in accordance with the attached revised threshold markings for precision and non-precision runways. Heliports shall be marked in accordance with Chapter 3 and 4 of UFC 3-260-05A. All other markings shall be in accordance with AF ETL 04-02 and AFI 32-1042.

3. Referenced documents can be found at the following web sites;

- a. UFC 3-260-05A: [http://www.wbdg.org/ccb/DOD/UFC/ufc\\_3\\_260\\_05a.pdf](http://www.wbdg.org/ccb/DOD/UFC/ufc_3_260_05a.pdf)
- b. AFI 32-1042: <http://www.e-publishing.af.mil/shared/media/epubs/AFI32-1042.pdf>
- c. AF ETL 04-02: [http://www.wbdg.org/ccb/AF/AFETL/etl\\_04\\_2.pdf](http://www.wbdg.org/ccb/AF/AFETL/etl_04_2.pdf)

4. Point of contact for this ECB is Paul Dicker, CECW-CE-D, 202-761-0995, [paul.f.dicker@usace.army.mil](mailto:paul.f.dicker@usace.army.mil) . Technical issues may be directed to John B. Gregory, USACE Transportation Systems Center, 402-995-2403, [john.b.gregory@usace.army.mil](mailto:john.b.gregory@usace.army.mil)

//S//

JAMES C. DALTON, P.E.  
Chief, Engineering and Construction  
Directorate of Civil Works

**ATTACHMENT 1**

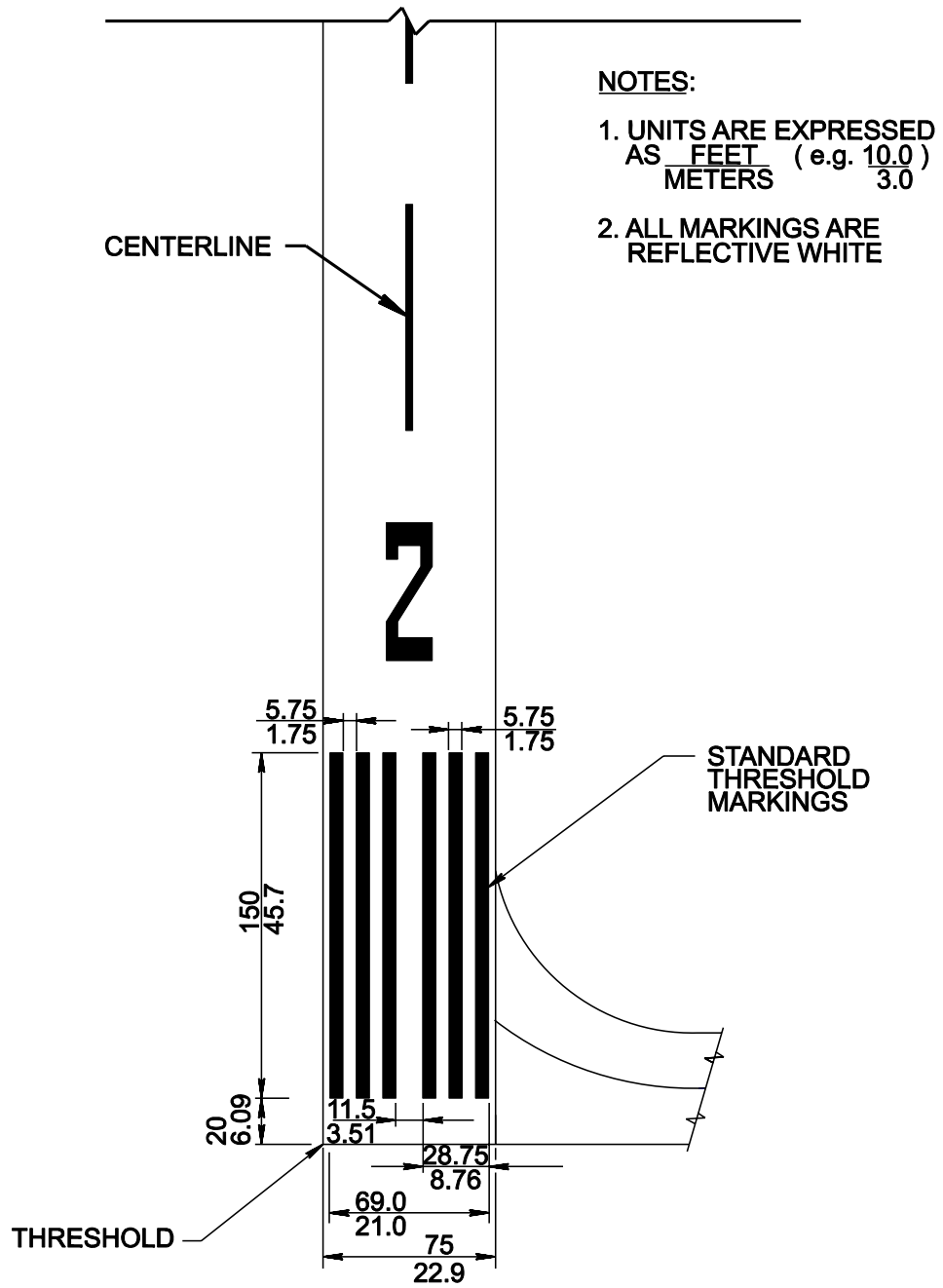

75 Foot Wide Runway  
Revised Non-Precision and Precision Runway  
Standard Threshold Runway Markings  
Revised 2008

**ATTACHMENT 2**

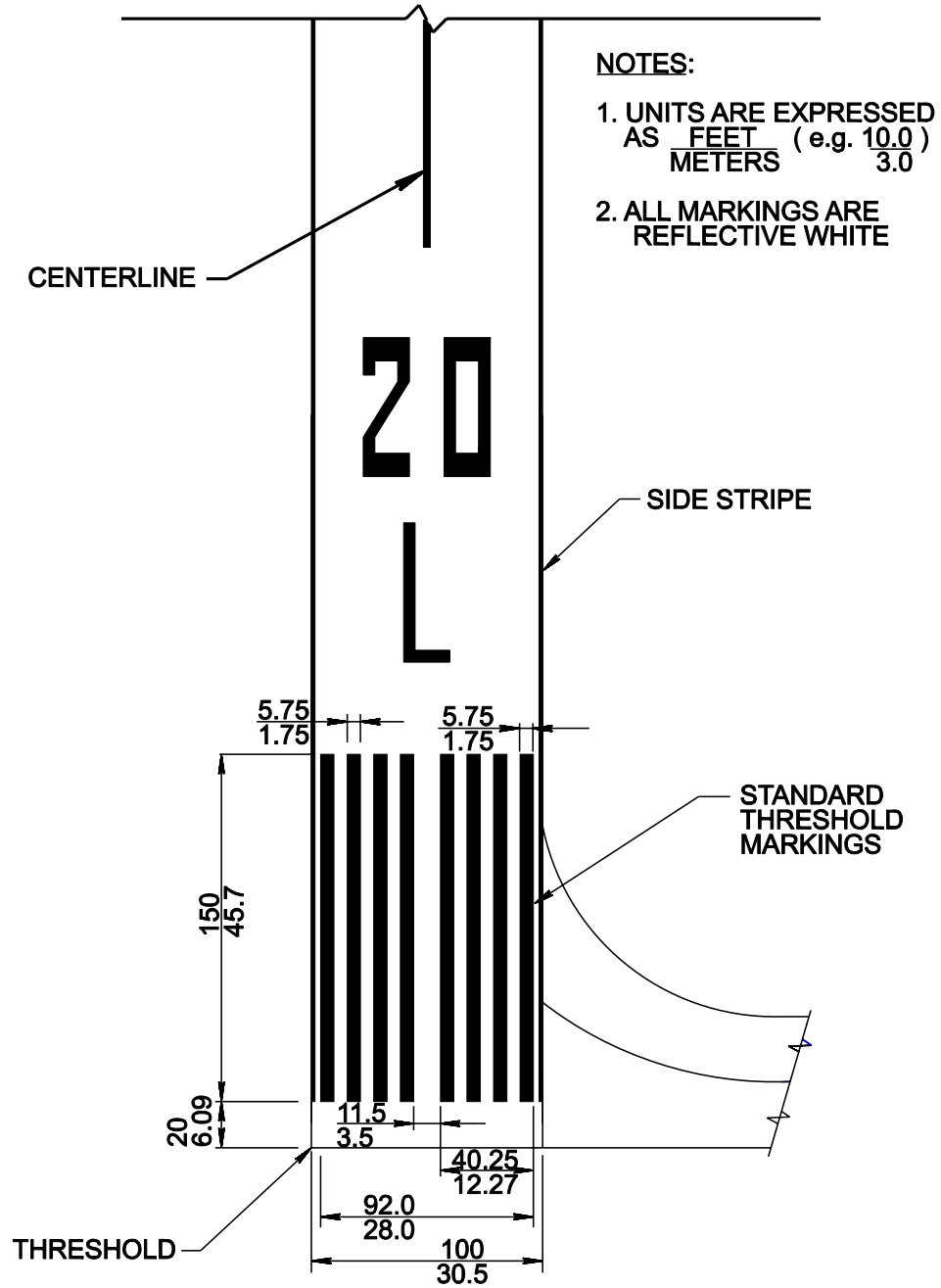

100 Foot Wide Runway  
Revised Precision and Nonprecision Instrument  
Standard Threshold Runway Markings  
Revised 2008

**ATTACHMENT 3**

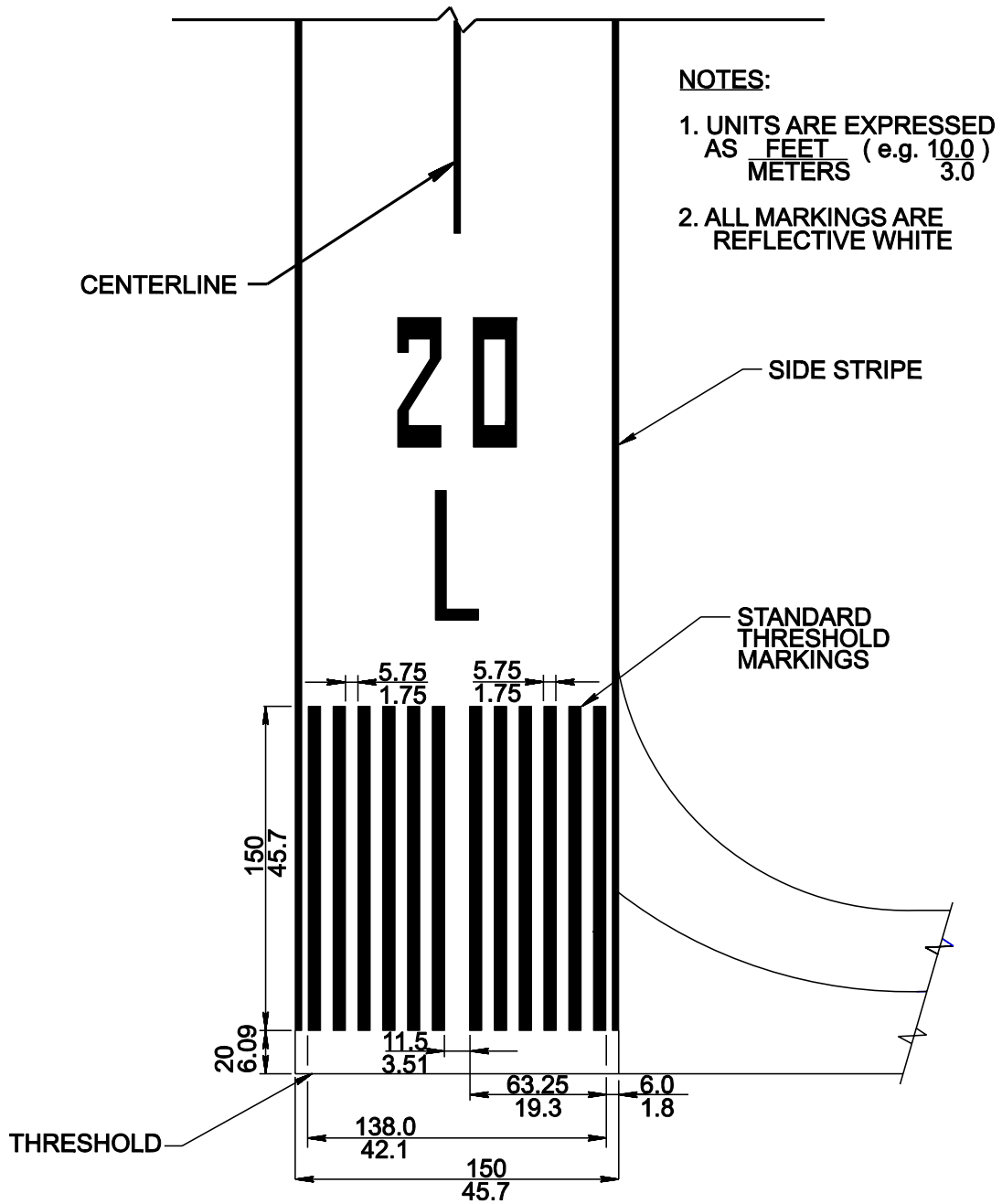

150 Foot Wide Runway  
Revised Precision and Nonprecision Instrument  
Standard Threshold Runway Markings  
Revised 2008

**ATTACHMENT 4**

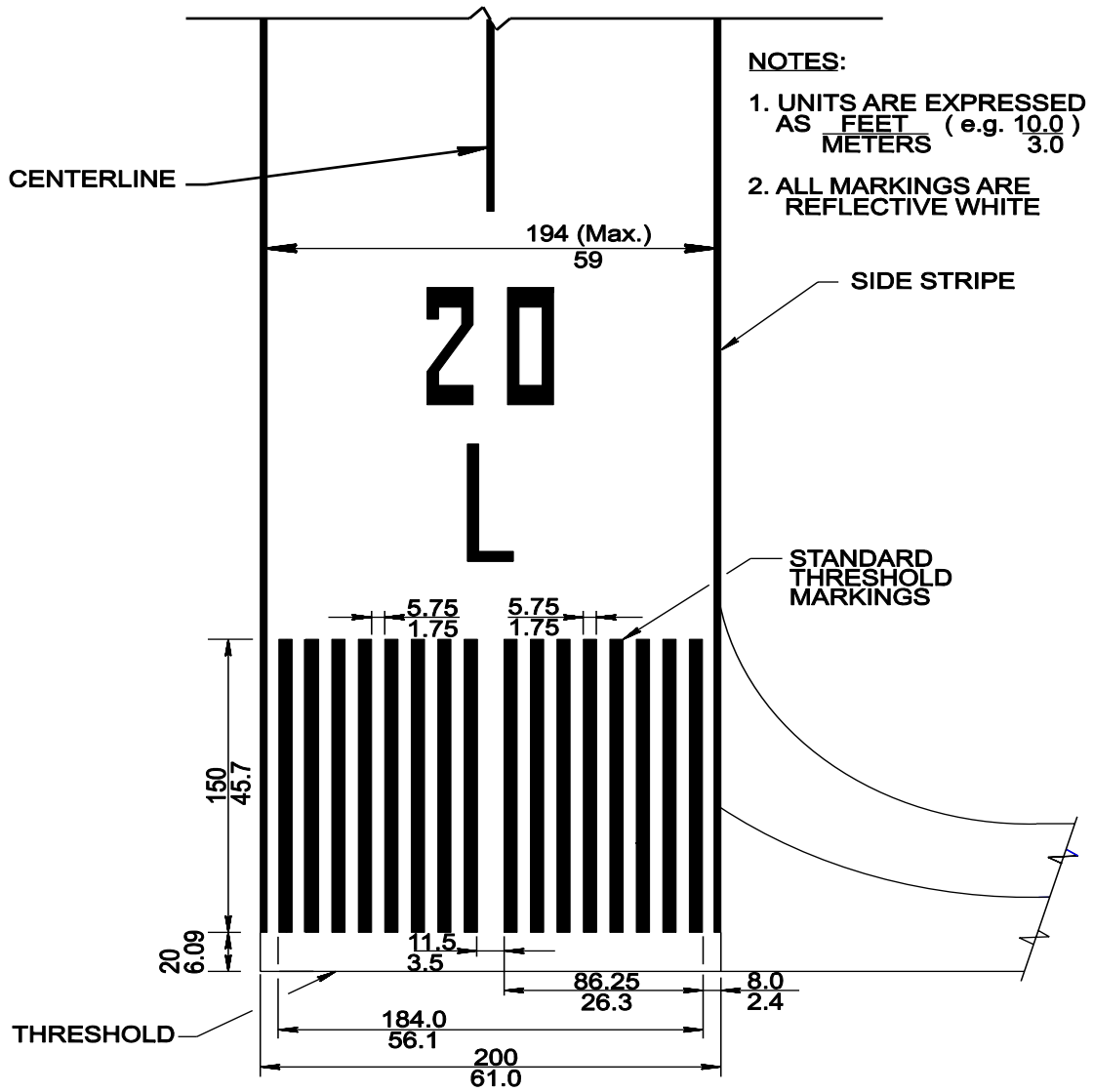

200 Foot and Wider Runways  
Revised Precision and Nonprecision Instrument  
Standard Threshold Runway Markings  
Revised 2008