

Air National Guard Handbook 32-1084
Facility Space Standards



Revised **20 March 2026**

AIR NATIONAL GUARD HANDBOOK 32-1084

FACILITY SPACE STANDARDS

ACCESSIBILITY: [NGB/A4FR 32-1084 SharePoint](#) and <https://www.wbdg.org/ffc/ang/handbooks-angh/32-1084>

RELEASABILITY: There are no release restrictions on this publication.

OPR: NGB/A4F

Certified by: NGB/A4 Deputy Director, Engineering

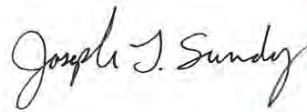

Digitally signed by
SUNDY.JOSEPH.T.1234263
273
Date: 2026.03.23 18:29:04
-04'00'

Supersedes: ANGH 32-1084, **31 October 2023**

Air National Guard Handbook (ANGH) 32-1084, *Facility Space Standards*, provides specific guidance for the Air National Guard (ANG), building upon and tailoring the broader Air Force Manual (AFMAN) 32-1024, *Facility Requirement Standards*, and its associated Air Force Guidance Memorandums (AFGMs). The Handbook provides guidance for determining functional space for ANG facilities and serves as a tool to program new facilities, modify existing spaces and manage real property inventory. The Functional Standards are organized by Category Code (CATCODE) and define specific functional, staffing, and space guidance. These Functional Standards define a basis for optimizing space in existing facilities, programming new facilities, and provide guidance for personnel engaged in planning, programming, designing, certifying, and approving ANG facilities. This Handbook does not authorize use of appropriated funds, non-appropriated funds, or private funds for construction or conversion of ANG facilities. Reference to a specific manufacturer, commercial product, or service in this Handbook does not imply endorsement by the Air National Guard or the United States Air Force.

SUMMARY OF CHANGES

This version corrects and supersedes ANGH 32-1084, *Facility Space Standards*, dated **31 October 2023**. The updated and new facility space standards have been revised with input from respective offices of primary responsibility (OPRs) and Functional Area Managers (FAMs). The updated document adds new space standards, corrects mathematical errors, and revises data and tables for some Category Codes (CATCODEs). Each change Item number is a hyperlink to the change and all changes are highlighted in Yellow. Use the Alt+Left Arrow to go back after clicking a hyperlink.

Item	CATCODE	Description	Page #	Para/Table	Comment	Addition/Deletion/Change
1	N/A	Previous version	iii	See above paragraph	Change previous version date	
2	171-445	Reserve Forces O & T, Flying Unit, 90 Personnel	6-13	Table 6-11	A-Staff removed.	Match 2 December 2025 FRAGORD 25-46B: Rescission of Wing Command Echelon Restructure
3	211-159	Aircraft Corrosion Control Summary	7-18	Table 7-18 Notes 5	Removed "Note 5" because it was moved into the table summary in 2012	Match approved Decision Memo for 211-159 to remove Note 5
4	171-447	Contingency Response Group, 160 Personnel	6-31	Table 6-29	Add in Table 7-3 and Figure 7-5 to demonstrate what is assigned 211-175	Match approved Decision Memo for 160 Personnel CRG

Item	CATCODE	Description	Page #	Para/Table	Comment	Addition/Deletion/Change
5	171-475	Range, Small Arms, Indoor 7, 10, and 14 Firing Lanes scope	6-61	Table 6-58 & Figure 6-1	Add the 7-lane scope which is being used for current designs	Changes to match coordinated project planning
6	171-476	Combat Arms Training Maintenance	6-64	Table 6-59 & Figure 6-4	Add the CATM to match the 7-lane range option	Match classroom and cleaning area
7	730-835	Security Forces Ops, Stand Alone, 74 Personnel	11-6	Table 11-4	Assigned equipment changes impact on square footage needs	Coordinated with Security Forces FAM
8	730-835	Security Forces Ops, Stand Alone, 87 Personnel	11-7	Table 11-5	Assigned equipment changes impact on square footage needs	Coordinated with Security Forces FAM
9	730-835	Security Forces Ops, Stand Alone, 118 Personnel	11-8	Table 11-6	Assigned equipment changes impact on square footage needs	Coordinated with Security Forces FAM
10	730-835	Security Forces Ops, Collocated, 61 Personnel	11-9	Table 11-7	Assigned equipment changes impact on square footage needs	Coordinated with Security Forces FAM
11	216-642	Conventional Munitions Shop	Page 7-32 to 7-34	Table 7-26 to Table 7-30	Added in the C-130J and F-15EX mission needs coordinated with the FAM	Match approved Decision Memo
12	211-152	Aircraft General Purpose Shops Details	Page 7-7	Table 7-5	Updated KC-46 Aircraft General Purpose Shops. Bathrooms and Mechanical were moved to the hangar 211-173, 211-175, or 211-177	Match approved Decision Memo and review comments to the Mission Grouped Hangars.
13	N/A	Table 1-1: UMD personnel counted in Functional Standards	Page 1-3	RIC 0160 and 8888	if there is a 15% Guard Drill Weekend increase then submit for a new Functional Standard	Clarification
14	116-672	Aircraft Wash Rack	Page 2-15	Section 2.14	Added: "Covered wash racks is existing hangar space."	Clarification
15	N/A	N/A	Page 2-16	Section 2.15.5	Added: "Air National Guard Engineer Technical Branch, NGB/A4IC"	Name Change
16	N/A	N/A	Page 1-13	Table 1-9: PAA Planning Factors	F-15EX planning factor is 1 - 18 PAA	A4FD review comment
17	116-945	Jet Blast Deflector	Page 2-17	Section 2-16	The unit of measure is linear feet (LF)	A4FD review comment
18	141-454	Tactical Operations	Page 5-10	Section 5.9	Name change from Special Operations to Tactical Operations	A4FD review comment
19	134-101	Wind Measurement Equipment	Page 4-11	Section 4.8	was 5.19 CATCODE 149-6XX, Fixed Base Automatic Meteorological Station (AN/FMQ-23) (New Mission)	Reflect updated CATCODE as the 149-6XX is no longer used. The title matched although 134-010 is not well defined. Will continue to monitor.
20	134-102	Automatic Meteorological Station	Page 4-11	Section 4.9	was 5.18 CATCODE 149-XX1, Automatic Meteorological Station (AN/FMQ-19) (New Rqmnt)	Reflect updated CATCODE as the 149-XX1 is no longer used. The description matched although 134-102 is not well defined. Will continue to monitor.

Item	CATCODE	Description	Page #	Para/Table	Comment	Addition/Deletion/Change
21	171-443	Contingency Response Flight, 31 Personnel	Page 6-9	Note 2 for Table	Added in Note 2 stating the "Contingency Response Flight, 31 Personnel replaced the Airlift Control Flight (ALCF) / Tactical Airlift Control Element (TALCE), 50 Personnel"	Clarification that the ANGH 32-1084 reflects mission change and shows any reference to Airlift Control shows it has been replaced.
22	141-753	Air Support Operations Squadron (ASOS)	Page 5-65 and 5-66	Table 5-37, 5-38, & 5-39	Updated ASOS Functional Standards to match UMD changes throughout the ANG	Match approved Decision Memo
23	311-114	Aircraft Dynamic Research Engineering Facility	Page 8-1	Section 8-2	Added in CATCODE and description	Match past approvals in the 920
24	141-454	Electromagnetic Warfare Squadron	Page 5-25	Table 5-12	Name change from Offensive Space Control Squadron (OSC) to Electromagnetic Warfare Squadron (EWS)	Clarification
25	149-962	Air Traffic Control (ATC) Tower	Page 5-78	Section 5.18.2.3	Added the conditions the 6,700 SF is sufficient when the control tower cab is on the 9th level and to coordinate for approval if the tower cab is higher.	Clarification
26	149-967	Observation Tower	Page 5-78	Section 5-19	Added in "UOM is EA, typical 80 Gross SF platform and are usually at least 20 meters (65.6 ft) tall with 360-degree range of vision per AF description."	Clarification, to specify the UOM and AF CATCODE description per A\$FD comment
27	113-321	Apron	Page 2-6	Section 2.5.3.2	Added 2.5.3.2 to match AF CATCODE 113-321 description that states C-17, C-130, KC-135, and KC-46 parking aprons subtract the hangar spots which is what ANG Basing has used for a long time.	Match NGB/A4F approval to align the ANGH 32-1084 with AF CATCODE and ANG Basing description for C-17, C-130, KC-135, and KC-46 parking apron will be PAA minus hangar spots.
28	141-459	Fighter Alert Crew Readiness	Page 5-27	Table 5-14 and Figure 5-1	Added Table 5 14: CATCODE 141-459, Fighter Alert Crew Readiness and Figure 5 1: Fighter Alert Crew Quarters, ACC/ASA Guide	Clarification of long-standing Functional standard that has been used for projects dating back to 2004
29	141-459	Tanker Alert Crew Readiness	Page 5-28	Section 5.10.3	Section 5.10.3 Added "only units with standing alert will be prioritized for construction." and updated Table 5 15: CATCODE 141-459, Tanker Alert Crew Readiness, 4/6/8 Personnel	Per direct A4F feedback
30	211-179	Fuel System Maintenance Dock	Page 7-20	Table 7-18 and Figure 7-11	For the F-15EX when a Conformal Fuel Tank (CFT) Tester is provided first use excess shop space when available as long as there is direct hangar bay access. Figure 7-11 shows one option if direct access shop space is not available.	To match approval package. The CFT Tester increases the F-15EX 211-179 Functional Standard to 10,400 SF.
31	141-753	Sqd Ops, F-15EX, 82 Personnel	5-34	Table 5 19:to include notes area	The F-15EX Basing efforts did a line-by-line review for the Sqd Ops Functional Standard	To match approval package

Item	CATCODE	Description	Page #	Para/Table	Comment	Addition/Deletion/Change
32	171-212	Sim Training Summary by Aircraft / Mission	9-3	Table 6-1	Added in F-15EX	Allows for the backseater spot on the stationary simulator
33	131-111	Telecommunications Function	4-7	Note 2 under Table 4-4	G-ASNT CATCODE 131-111 increase from 500 SF to 1,000SF	To match approval package
34	422-264	Storage Igloo	9-2	Table 9-2	Added in F-15EX which has larger and more in quantity. Coordinated with FAM to use half size or smaller igloos to conserve square footage while meeting the mission needs	To match approval package

Table of Contents

Chapter 1: Facility Space Standards..... 1-1

- 1.1 Purpose..... 1-1
- 1.2 Applicability 1-1
- 1.3 Authority 1-1
- 1.4 Handbook Focus 1-1
- 1.5 Organization..... 1-2
- 1.6 Definitions 1-3
 - Table 1-1: UMD personnel counted in Functional Standards 1-3
 - Table 1-2: ANG Northern Tier Locations per 2022 NWS NCEI data 1-5
- 1.7 Administrative Area Standards 1-6
 - Table 1-3: Administrative Work Areas 1-7
 - Figure 1-1: Typical Cubicle and Hoteling, the 64 SF and 24 SF, including circulation..... 1-7
 - Figure 1-2: Typical Operations Floor, 42 SF includes circulation and NIPR/SIPR separation needs.. 1-7
 - Table 1-4: Typical Assembly Space..... 1-8
 - Figure 1-3: Typical Assembly Space and Conference Room Space 1-8
 - Table 1-5: Conference and Meeting Space 1-9
 - Table 1-6: Training and Testing Space 1-9
- 1.8 Overhead Factor..... 1-10
 - Table 1-7: Facility Function Overhead Percentage 1-10
- 1.9 Scope Calculations..... 1-11
 - Table 1-8: Example Scope Calculations 1-11
- 1.10 Aircraft Authorization Planning Factors..... 1-13
 - Table 1-9: PAA Planning Factors 1-13
- 1.11 Physical Fitness Areas 1-13
- 1.12 Personal Mobility Equipment 1-14
- 1.13 Lactation Rooms for Nursing Mothers 1-14
- 1.14 How To Use this Handbook..... 1-14
- 1.15 Functional Standards & CATCODE Adjustments (Appendix B): 1-15
- 1.16 Responsibilities..... 1-16

Chapter 2: Category Group 11 – Airfield Pavements..... 2-1

- 2.1 General Criteria..... 2-1
- 2.2 CATCODE 111-111, Runway 2-2
 - Table 2-1: CATCODE 111-111, Minimum Runway Lengths for Fully Loaded Mission Aircraft 2-2
 - Table 2-2: CATCODE 111-111, Runway Clear Zone, Ends of Runway & Centerline 2-2
- 2.3 CATCODE 111-115, Paved Overrun 2-3
 - Table 2-3: CATCODE 111-115, Paved Overrun 2-3
- 2.4 CATCODE 112-211, Taxiway 2-4
 - Table 2-4: CATCODE 112-211, Taxiway 2-4
- 2.5 CATCODE 113-321, Apron 2-5
 - Table 2-5: CATCODE 113-321, Aircraft Dimensional Criteria 2-5
 - Table 2-6: CATCODE 113-321, Apron Taxi Lanes 2-6
- 2.6 CATCODE 116-116, Short Field Take-off and Landing Zone 2-7

	Table 2-7: CATCODE 116-116, Short Field Take-off and Landing Zone	2-7
2.7	CATCODE 116-642, Paved Shoulders.....	2-8
	Table 2-8: CATCODE 116-642, Refuelers, C-130s, C-17 Shoulders on each side	2-8
	Table 2-9: CATCODE 116-642, Exclusive Fighters, Trainers Shoulders on each side	2-8
	Figure 2-1: CATCODE 116-642, Class B Runway & Taxiway Shoulder Example	2-8
2.8	CATCODE 116-661, Arm / Disarm Pad	2-9
2.9	CATCODE 116-662, Hazardous Cargo Pad.....	2-10
2.10	CATCODE 116-664, Unsuppressed Power Check Pad.....	2-11
	Table 2-10: CATCODE 116-664, Unsuppressed Power Check Pad.....	2-11
2.11	CATCODE 116-665, Power Check Pad (with Noise Suppressor)	2-12
2.12	CATCODE 116-666, Warm-Up / Holding Pad	2-13
2.13	CATCODE 116-667, Compass Calibration Pad.....	2-14
2.14	CATCODE 116-672, Aircraft Wash Rack	2-15
2.15	CATCODE 116-922, Aircraft Arresting System (AAS)	2-16
	Table 2-11: CATCODE 116-922, Aircraft Arresting Systems Siting Criteria	2-16
2.16	CATCODE 116-945, Jet Blast Deflector.....	2-17

Chapter 3: Category Group 12 – Petroleum Dispensing and Operating Facilities..... 3-1

3.1	General Criteria.....	3-1
3.2	CATCODE 121-111, Petroleum Operations Building	3-2
	Table 3-1: CATCODE 121-111, POL Operations Building, 7 / 16 / 29 Personnel.....	3-2
3.3	CATCODE 121-122, Hydrant Fueling System	3-3
3.4	CATCODE 121-124, Hydrant Fueling Building	3-4
3.5	CATCODE 123-335, Vehicle Fueling Station (Base Service Station).....	3-5
3.6	CATCODE 124-134, Operating Storage, Diesel	3-6
3.7	CATCODE 124-135, Operating Storage, Jet Fuel.....	3-7
	Table 3-2: CATCODE 124-135, Jet Fuel Storage Capacity (planning only).....	3-7
3.8	CATCODE 124-137, Operating Storage, Motor Gas	3-8
3.9	CATCODE 125-977, Pump Station, Liquid Fuel	3-9
3.10	CATCODE 126-925, Liquid Fuel Truck Fill Stand	3-10
3.11	CATCODE 126-926, Liquid Fuel Truck Unloading Stand	3-11

Chapter 4: Category Group 13 – Communications, NavAids, Air Traffic Control, & Airfield Lighting4-1

4.1	General Criteria.....	4-1
4.2	CATCODE 130-142, Fire Crash/Rescue Station.....	4-2
	Table 4-1: CATCODE 130-142, Fire Crash / Rescue Station Vehicle Apparatus Sets.....	4-2
	Table 4-2: CATCODE 130-142, Aircraft Rescue Fire Fighting Stations Categories.....	4-4
	Table 4-3: CATCODE 130-142, Aircraft Rescue Fire Fighting Stations Summary	4-5
4.3	CATCODE 131-111, Telecommunications	4-6
	Table 4-4: CATCODE 131-111, Telecommunications Function, 37 Personnel	4-6
	Figure 4-1: G-ASNT Transportable Layouts collocated or standalone	4-7
	Table 4-5: CATCODE 131-111, Regional Operations Support Center (ROSC), 10 Personnel.....	4-8
	Table 4-6: CATCODE 131-111, Telecommunications Regional Training Center (RTC)	4-8
4.4	CATCODE 131-115, Communications Receiver.....	4-9
4.5	CATCODE 131-116, Communications Transmitter/Receiver	4-9

4.6	CATCODE 131-117, Communications Transmitter	4-9
4.7	CATCODE 132-133, Equipment Pad.....	4-10
4.8	CATCODE 134-101, Wind Measurement Equipment	4-11
4.9	CATCODE 134-102, Automatic Meteorological Station.....	4-11
4.10	CATCODE 134-341, Mobile Radar Support.....	4-12
	Figure 4-2: D-ILS equipment Pad	4-12
	Table 4-7: CATCODE 134-341, Mobile Radar Support, 37 Personnel	4-12
4.11	CATCODE 134-351, Instrument Landing System (ILS) Glide Slope	4-14
4.12	CATCODE 134-353, Instrument Landing System (ILS) Localizer	4-14
4.13	CATCODE 134-375, Radar Approach Control (RAPCON)	4-14
4.14	CATCODE 134-376, Airport Surveillance Radar (ASR).....	4-15
4.15	CATCODE 134-465, Tactical Air Navigation (TACAN)	4-15
4.16	CATCODE 134-511, VORTAC, Fixed.....	4-15
4.17	CATCODE 136-661, Approach Lighting.....	4-16
4.18	CATCODE 136-664, Runway Lighting	4-16
4.19	CATCODE 136-667, Taxiway Lighting.....	4-16
Chapter 5:	Category Group 14 – Land Operational Facilities.....	5-1
5.1	General Criteria.....	5-1
5.2	CATCODE 140-422, Secure Space Mission Planning Cell, Flying Wings	5-2
5.3	CATCODE 141-165, Explosive Ordnance Disposal (EOD) Facility	5-3
	Table 5-1: CATCODE 141-165, Explosive Ordnance Disposal Facility, 7 / 10 Personnel	5-3
5.4	CATCODE 141-181, Aircraft Shelter	5-5
5.5	CATCODE 141-183, Fighter Aircraft Alert Hangar	5-5
5.6	CATCODE 141-185, Guardian Angel.....	5-6
	Table 5-2: CATCODE 141-185, Guardian Angel, 108 Personnel	5-6
5.7	CATCODE 141-383, Audio / Visual.....	5-8
	Table 5-3: CATCODE 141-383, Audio / Visual.....	5-8
5.8	CATCODE 141-453, Base Operations	5-9
	Table 5-4: CATCODE 141-453, Base Operations	5-9
5.9	CATCODE 141-454, Tactical Operations	5-10
	Table 5-5: CATCODE 141-454, STS, 127 Personnel.....	5-10
	Table 5-6: CATCODE 141-454, Cyber ISR Group, 206 Personnel.....	5-12
	Table 5-7: CATCODE 141-454, Cyber ISR Sqd, 71 Personnel.....	5-14
	Table 5-8: CATCODE 141-454, Targeting Intel Production Group, 206 Personnel	5-15
	Table 5-9: CATCODE 141-454, Targeting Intel Production Sqd, 107 Personnel	5-18
	Table 5-10: CATCODE 141-454, DCGS Group (Large), 408 Personnel	5-19
	Table 5-11: CATCODE 141-454, DCGS Group (Small), 240 Personnel	5-22
	Table 5-12: CATCODE 141-454, Electromag Warfare Squadron, 88 Personnel	5-25
	Table 5-13: CATCODE 141-454, Defensive Space Control Sqd, 88 Personnel.....	5-26
5.10	CATCODE 141-459, Crew Readiness	5-27
	Table 5-14: CATCODE 141-459, Fighter Alert Crew Readiness	5-27
	Figure 5-1: Fighter Alert Crew Quarters, ACC/ASA Guide	5-27
	Table 5-15: CATCODE 141-459, Tanker Alert Crew Readiness, 4/6/8 Personnel	5-28
5.11	CATCODE 141-461, Command Post.....	5-29

	Table 5-16: CATCODE 141-461, Command Post, 36 Personnel	5-29
5.12	CATCODE 141-753, Squadron Operations (Sqd Ops)	5-31
	Table 5-17: CATCODE 141-753, Squadron Operations Summary	5-31
	Table 5-18: CATCODE 141-753, Sqd Ops, F-15 / F-16 , 88 Personnel	5-32
	Table 5-19: CATCODE 141-753, Sqd Ops, F-15EX , 82 Personnel	5-34
	Table 5-20: CATCODE 141-753, Sqd Ops, F-22 / F-35, 88 Personnel	5-36
	Table 5-21: CATCODE 141-753, Sqd Ops, C-130, 153 Personnel	5-38
	Table 5-22: CATCODE 141-753, Sqd Ops, C-130J, 123 Personnel.....	5-40
	Table 5-23: CATCODE 141-753, Sqd Ops, C-17, 186 Personnel	5-42
	Table 5-24: CATCODE 141-753, Sqd Ops C-38 / C-40, 72 Personnel	5-44
	Table 5-25: CATCODE 141-753, Sqd Ops C-32, 48 Personnel	5-45
	Table 5-26: CATCODE 141-753, Sqd Ops, KC-135 One Sqd, 119 Personnel	5-46
	Table 5-27: CATCODE 141-753, Sqd Ops, KC-135 One Sqd (Active Association), 138 Personnel	5-48
	Table 5-28: CATCODE 141-753, Sqd Ops, KC-135 Two Sqdns, 178 Personnel	5-50
	Table 5-29: CATCODE 141-753, Sqd Ops, KC-46 One Sqd 12PAA (Active Association), 230 Personnel.....	5-52
	Table 5-30: CATCODE 141-753, Sqd Ops, KC-46 One Sqd 12PAA, 228 Personnel.....	5-54
	Table 5-31: CATCODE 141-753, Sqd Ops, KC-46 One Sqd 8PAA (Active Association), 177 Personnel.....	5-56
	Table 5-32: CATCODE 141-753, Sqd Ops, KC-46 One Sqd 8PAA, 149 Personnel	5-58
	Table 5-33: CATCODE 141-753, Sqd Ops, Rescue HC-130 /HH-60, 171 Personnel.....	5-60
	Table 5-34: CATCODE 141-753, Sqd Ops, RPA, 213 Personnel	5-63
	Table 5-35: CATCODE 141-753, Sqd Ops, CRTC, 52 personnel	5-65
	Table 5-36: CATCODE 141-753, Air Support Ops Group Admin, 39 Personnel	5-66
	Table 5-37: CATCODE 141-753, Air Support Ops Sqd, Admin, 85 Personnel	5-67
	Table 5-38: CATCODE 141-753, Air Support Ops Squad, Shops, 20 Personnel	5-68
	Table 5-39: CATCODE 141-753, Air Support Ops Squad Admin and Shop Total	5-68
5.13	CATCODE 141-783, Small Air Terminal (SAT).....	5-69
	Table 5-40: CATCODE 141-783, Small Air Terminal KC-135, 28 Personnel.....	5-69
	Table 5-41: CATCODE 141-783, Small Air Terminal KC-46, 32 Personnel.....	5-71
	Table 5-42: CATCODE 141-783, Small Air Terminal C-17, 46 Personnel.....	5-72
	Table 5-43: CATCODE 141-783, Small Air Terminal C-130, 48 Personnel.....	5-73
	Table 5-44: CATCODE 141-783, Small Air Terminal HC-130, 24 Personnel.....	5-74
5.14	CATCODE 141-786, Deployment Processing Center.....	5-75
	Table 5-45: CATCODE 141-786, Deployment Processing Center, No SAT.....	5-75
	Table 5-46: CATCODE 141-786, Deployment Processing Center, Collocated with SAT	5-76
5.15	CATCODE 145-921, Overhead Protection	5-77
	Figure 5-2: Use CATCODE 145-921, Overhead Protection, only when not connected to the Gatehouse	5-77
5.16	CATCODE 149-511, RPA Support Operations Center (SOC)	5-78
	Table 5-47: CATCODE 149-511, RPA Support Ops Center, 72 Personnel per Shift.....	5-78
5.17	CATCODE 149-621, Wind Measuring Set (AN/FMQ-13).....	5-80
5.18	CATCODE 149-962, Air Traffic Control (ATC) Tower.....	5-81
5.19	CATCODE 149-967, Observation Tower	5-81
Chapter 6:	Category Group 17 – Training Facilities	6-1
6.1	General Criteria.....	6-1

6.2	CATCODE 171-211, Flying Training Classroom	6-1
6.3	CATCODE 171-212, Simulator Training	6-3
	Table 6-1: CATCODE 171-212, Sim Training Summary by Aircraft / Mission	6-3
	Table 6-2: CATCODE 171-212, Simulator Training, F-16 MTC, 4 Mission Simulators	6-5
	Table 6-3: CATCODE 171-212, Simulator Training, F-16 MTC, 2 Mission Simulators	6-5
6.4	CATCODE 171-443, Reserve Forces General Training Support	6-6
	Table 6-4: CATCODE 171-443, Honor Guard Flight - 30 Personnel	6-6
	Table 6-5: CATCODE 171-443, Services Flight - 20 / 30 / 41 / 51 Personnel	6-7
	Table 6-6: CATCODE 171-443, Combat Weather Flight, 15 Personnel	6-8
	Table 6-7: CATCODE 171-443, Special Operations Weather Team, 18 Personnel	6-9
	Table 6-8: CATCODE 171-443, Contingency Response Flight, 31 Personnel	6-10
	Table 6-9: CATCODE 171-443, F-15 Enhanced Eagle Test Center (EETC), 7 Personnel	6-11
6.5	CATCODE 171-445, Reserve Forces Operational Training	6-12
	Table 6-10: CATCODE 171-445, Reserve Forces O & T, Flying Unit, 90 Personnel	6-12
	Table 6-11: CATCODE 171-445, RPA Formal Training Unit (FTU), 54 Personnel	6-14
	Table 6-12: CATCODE 171-445, Reserve Forces O & T - CRTC	6-15
	Table 6-13: CATCODE 171-445, Reserve Forces O & T – 26 Prsnl, 1/2 RED HORSE Sqd	6-16
	Table 6-14: CATCODE 171-445, Reserve Forces O & T – 17 Prsnl, 1/4 RED HORSE Sqd	6-17
	Table 6-15: CATCODE 171-445, Reserve Forces O & T – REOTS, 15 Personnel	6-18
	Table 6-16: CATCODE 171-445, Reserve Forces O & T – RTS, 12 Personnel	6-19
	Table 6-17: CATCODE 171-445, Reserve Forces O & T - Lightning Force Academy, 30 Pn	6-20
6.6	CATCODE 171-447, Reserve Forces Communications & Electronics Training	6-21
	Table 6-18: CATCODE 171-447, Combat Comm Group, 46 Personnel	6-21
	Table 6-19: CATCODE 171-447, Combat Comm Sqd Admin, 108 Personnel	6-23
	Table 6-20: CATCODE 171-447, Combat Comm Sqd Shop	6-24
	Table 6-21: CATCODE 171-447, Combat Comm Sqd Admin and Shop Total	6-24
	Table 6-22: CATCODE 171-447, Collocated Combat Comm Group / Sqd Admin, 163 Personnel ..	6-25
	Table 6-23: CATCODE 171-447, Collocated Combat Comm Group / Sqd Shop	6-27
	Table 6-24: CATCODE 171-447, Collocated Combat Comm Group / Sqd Admin and Shop Total .	6-27
	Table 6-25: CATCODE 171-447, ACS / CRC, Admin, 186 Personnel	6-28
	Table 6-26: CATCODE 171-447, ACS / CRC Shop	6-29
	Table 6-27: CATCODE 171-447, ACS / CRC Admin and Shop Total	6-30
	Table 6-28: CATCODE 171-447, Contingency Response Group Admin, 153 Personnel	6-31
	Table 6-29: CATCODE 171-447, Contingency Response Group Shop, 7 Personnel	6-32
	Table 6-30: CATCODE 171-447, Contingency Response Group, Admin and Shop Total	6-32
	Table 6-31: CATCODE 171-447, Air Traffic Control Sqd Admin	6-33
	Table 6-32: CATCODE 171-447, Air Traffic Control Sqd Shops	6-34
	Table 6-33: CATCODE 171-447, Air Traffic Control Sqd Admin and Shops Total	6-34
	Table 6-34: CATCODE 171-447, Engineering Installation Sqd Admin	6-35
	Table 6-35: CATCODE 171-447, Engineering Installation Sqd Shops	6-36
	Table 6-36: CATCODE 171-447, Engineering Installation Sqd Admin and Shops Total	6-36
	Table 6-37: CATCODE 171-447, Info Warfare Aggressor Sqd, 104 Personnel	6-37
	Table 6-38: CATCODE 171-447, Cyber Ops Sqd Defense, Hunter, 73 Personnel	6-39
	Table 6-39: CATCODE 171-447, Field Maintenance Comm Electronics, MQ-9, 29 Personnel	6-41
	Table 6-40: CATCODE 171-447, Joint Communications Support Sqd (JCSS), 200 Personnel	6-42
	Table 6-41: CATCODE 171-447, AOG with JAOC and JWIC, 145 Personnel	6-44

	Table 6-42: CATCODE 171-447, AOG with JAOC, 144 Personnel	6-46
	Table 6-43: CATCODE 171-447, AOG, admin only (no Ops floor), 131 Personnel	6-47
	Table 6-44: CATCODE 171-447, AOG with JAOC, AFFOR & JWIC, 250 Personnel	6-48
	Table 6-45: CATCODE 171-447, AOG with JAOC, AFFOR & JWIC, 301 Personnel	6-50
6.7	CATCODE 171-449, Reserve Forces Aeromedical Evacuation Training.....	6-52
	Table 6-46: CATCODE 171-449, AeroMed Evac Training, 117 Personnel.....	6-52
6.8	CATCODE 171-450, Reserve Forces Medical Training / Administration.....	6-54
	Table 6-47: CATCODE 171-450, Med Training Admin	6-54
	Table 6-48: CATCODE 171-450, Med Training (Training Area)	6-55
	Table 6-49: CATCODE 171-450, Med Training Admin & Training.....	6-55
	Table 6-50: CATCODE 171-450, Med Training, Tenant	6-56
	Table 6-51: CATCODE 171-450, Med Training, GSU	6-57
	Table 6-52: CATCODE 171-450, Med Training CRTC (Full-Time)	6-58
	Table 6-53: CATCODE 171-450, Med Training, Visiting Unit	6-58
	Table 6-54: CATCODE 171-450, Med Training CRTC Total.....	6-58
	Table 6-55: CATCODE 171-450, EMEDS-CM Admin / Trng, 47 Personnel.....	6-59
6.9	CATCODE 171-471, Range Control House (RCH).....	6-60
	Table 6-56: CATCODE 171-471, Range Control House (RCH)	6-60
6.10	CATCODE 171-472, Range Supply and Equipment Storage	6-60
6.11	CATCODE 171-473, Range Target Storage and Repair	6-60
6.12	CATCODE 171-475, Range, Small Arms, Indoor	6-61
	Table 6-57: CATCODE 171-475, Range, Small Arms, Indoor 7, 10, and 14 Firing Lanes scope.....	6-61
	Figure 6-1: CATCODE 171-475, Indoor Small Arms Range 7 Lane Template	6-62
	Figure 6-2: CATCODE 171-475, Indoor Small Arms Range elevated control booth and firing line	6-63
	Figure 6-3: CATCODE 171-475, Indoor Small Arms Range showing ventilation control panel in control booth	6-63
6.13	CATCODE 171-476, Combat Arms Training Maintenance (CATM)	6-64
	Table 6-58: CATCODE 171-476, Combat Arms Training Maintenance.....	6-64
	Figure 6-4: CATCODE 171-476, CATM Template	6-64
6.14	CATCODE 171-618, Field Training Facility	6-65
	Table 6-59: CATCODE 171-618, RPA Field Training Detachment.....	6-65
	Table 6-60: CATCODE 171-618, RPA Mission Control Element (MCE) FTD.....	6-66
	Table 6-61: CATCODE 171-618, Field Training Facility, Battlefield Airmen Gym	6-67
	Figure 6-5: CATCODE 171-618, Field Training Facility, Battlefield Airmen Gym, ASOS	6-67
6.15	CATCODE 171-875, Munitions Loading Crew Training Facility	6-68
	Table 6-62: CATCODE 171-875, Munitions Loading Crew Training	6-68
6.16	CATCODE 179-371, Miscellaneous Training.....	6-69
6.17	CATCODE 179-475, Small Arms Range, Outdoor.....	6-70
	Figure 6-6: CATCODE 179-475, Small Arms Range, Outdoor	6-70
6.18	CATCODE 179-481, Aircraft Range	6-72
6.19	CATCODE 179-511, Fire Fighter Training Facility	6-73
	Table 6-63: CATCODE 179-511, Fire Fighter Training Facility, Summary	6-73
Chapter 7:	Category Group 21 – Maintenance Facilities.....	7-1
7.1	General Criteria.....	7-1
	Table 7-1: Air National Guard Mission Grouped Maintenance Hangar Sizes Summary.....	7-1

Figure 7-1: WBDG (Link) to published ANG Mission Grouped Hangar Sizes..... 7-1
Figure 7-2: Typical Mx Hangar Bathroom..... 7-2

7.2 CATCODE 211-173, Large Aircraft Maintenance Dock7-2
Figure 7-3: Six Mission Grouped Fighter with Single Door Hangar Bay Size 7-2
Table 7-2: 211-173, Large Aircraft Maintenance Dock Summary..... 7-3
Figure 7-4: Airlift/Tanker Large Mx Hangar Bay proof of concept and an existing project. 7-3

7.3 CATCODE 211-175, Medium Aircraft Maintenance Dock for Fighters7-4
Table 7-3: CATCODE 211-175, Medium Aircraft Maintenance Dock Aircraft¹ 7-4
Figure 7-5: CATCODE 211-175, Medium Mx Hangar Bay Layouts 7-4

7.4 CATCODE 211-177, Small Aircraft Maintenance Dock, C-130J-30 and smaller aircraft7-5
Table 7-3: CATCODE 211-177, Small Aircraft Maintenance Dock Aircraft¹ 7-5
Figure 7-6: C-130 and C-130J-30 Stretched Maintenance Hangar Size 7-5
Figure 7-7: CRTC Maintenance Hangar 7-5
Figure 7-8: MQ-1 and MQ-9, UAV Maintenance Final Design Guide..... 7-6

7.5 CATCODE 211-152, Aircraft General Purpose Shops7-7
Table 7-4: CATCODE 211-152, Aircraft General Purpose Shops Details 7-7
Table 7-5: CATCODE 211-152, Aircraft General Purpose Shops, RPA 7-7
Table 7-6: CATCODE 211-152, Aircraft General Purpose Shops Summary 7-8

7.6 CATCODE 211-153, Non-Destructive Inspection Shop.....7-9
Table 7-7: CATCODE 211-153, Non-Destructive Inspection Shop 7-9

7.7 CATCODE 211-154, Aircraft Organizational Maintenance Shop (AMU)7-10
Table 7-8: CATCODE 211-154, Aircraft Org Mx Shop, Fighter, 120 Personnel..... 7-10
Table 7-9: CATCODE 211-154, Aircraft Org MX Shop, KC-135/C-17/C-130, 60 Personnel..... 7-11
Table 7-10: CATCODE 211-154, Aircraft Org MX Shop, KC-46, 90 Personnel..... 7-12
Table 7-11: CATCODE 211-154, Aircraft Org MX Shop, Rescue, 95 Personnel..... 7-13
Table 7-12: CATCODE 211-154, Aircraft Org Mx, RPA LRE, 40 Personnel 7-14
Table 7-13: CATCODE 211-154, Aircraft Organizational Maintenance Shops Summary 7-14

7.8 CATCODE 211-157, Jet Engine Inspection and Maintenance Shop7-15
Table 7-14: CATCODE 211-157, Jet Engine Inspection and Maintenance Shop Details 7-15
Figure 7-9: CATCODE 211-157, F-35 Jet Engine Storage example 7-16
Table 7-15: CATCODE 211-157, Jet Engine Inspection and Maintenance Shop (Continued)..... 7-16
Table 7-16: CATCODE 211-157, Jet Engine Inspection and Maintenance Shop Summary 7-17

7.9 CATCODE 211-159, Aircraft Corrosion Control.....7-18
Table 7-17: CATCODE 211-159, Aircraft Corrosion Control Summary 7-18

7.10 CATCODE 211-161, Corrosion Control Utility Storage.....7-19
Figure 7-10: CATCODE 211-161, Corrosion Control Utility Storage 7-19

7.11 CATCODE 211-179, Fuel System Maintenance Dock7-20
Table 7-18: CATCODE 211-179, Fuel System Maintenance Dock Summary 7-20
Figure 7-11: CATCODE 211-179, Fighter Fuel System Mx Dock with Shops 7-20
Figure 7-12: F15-EX Drop Tank layout for 18 or 21PAA, each tank on cradles 7-20

7.12 CATCODE 211-193, Test Stand7-21

7.13 CATCODE 214-422, Vehicle Service Rack.....7-22
Figure 7-13: CATCODE 214-422 per 2016 AF Category Code book 7-22

7.14 CATCODE 214-425, Vehicle Maintenance Shop7-23
Table 7-19: CATCODE 214-425, Vehicle Maintenance Shop 7-23

	Figure 7-14: Proof of concept for Typical Vehicle Maintenance Admin, Shops, & Refueler	7-24
7.15	CATCODE 214-426, Vehicle Operations Heated Parking.....	7-25
	Figure 7-15: Example square footage for angled parking vs straight parking	7-25
7.16	CATCODE 214-428, Vehicle Operations Parking Shed	7-26
	Table 7-20: CATCODE 214-428, Vehicle Operations Parking Shed	7-26
7.17	CATCODE 214-467, Refueling Vehicle Shop	7-27
	Table 7-21: CATCODE 214-467, Refueling Vehicle Shop	7-27
7.18	CATCODE 215-552, Weapons and Release Systems Shop.....	7-28
	Table 7-22: CATCODE 215-552, Weapons and Release Systems, Fighters, Admin, 64 Personnel..	7-28
	Table 7-23: CATCODE 215-552, Weapons and Release Systems, Rescue HH-60 & HC-130, Admin, 12 Personnel.....	7-29
	Table 7-24: CATCODE 215-552, MQ-9, Remotely Piloted Aircraft (RPA), Total Admin and Shop	7-29
7.19	CATCODE 216-642, Conventional Munitions Shop	7-30
	Figure 7-16: CATCODE 216-642, Example Layout Admin, inert storage, and trailer Mx	7-30
	Figure 7-17: CATCODE 216-642, Example Layout M&I and Inspections.....	7-31
	Figure 7-18: CATCODE 216-642, Example Munitions Site Plan showing M&I separation to Inspections. The separation distance is always based on DDESB approved explosive site plans....	7-31
	Table 7-25: CATCODE 216-642, Conventional Munitions Shop, Admin	7-32
	Table 7-26: CATCODE 216-642, Conventional Munitions Shop, Trailer Maintenance	7-33
	Table 7-27: CATCODE 216-642, Conventional Munitions Shop, Maintenance	7-33
	Table 7-28: CATCODE 216-642, Conventional Munitions Storage	7-33
	Table 7-29: CATCODE 216-642, Conventional Munitions Shop Totals	7-34
7.20	CATCODE 217-712, Avionics Shop.....	7-35
	Table 7-30: CATCODE 217-712, Avionics Shop Summary	7-35
	Table 7-31: CATCODE 217-712, Avionics Shop Fighters Details	7-35
7.21	CATCODE 217-713, Electronic Countermeasures (ECM) Pod Shop and Storage.....	7-36
	Table 7-32: CATCODE 217-713, ECM Pod Shop and Storage	7-36
	Table 7-33: CATCODE 217-713, ECM Pod Shop and Storage for A-10 and F-16	7-36
	Figure 7-19: CATCODE 217-713, ECM Pod Shop/Storage Layouts	7-36
7.22	CATCODE 218-712, Aircraft Support Shop / Storage.....	7-37
	Table 7-34: CATCODE 218-712, Aircraft Support - Command & Control	7-37
	Table 7-35: CATCODE 218-712, Aircraft Support Equipment – Support	7-37
	Table 7-36: CATCODE 218-712, Aircraft Support Equipment - Storage	7-38
	Table 7-37: CATCODE 218-712, Aircraft Support Equipment Summary	7-38
7.23	CATCODE 218-868, Regional Precision Measurement Equipment Lab (PMEL)	7-39
	Table 7-38: CATCODE 218-868, Regional Precision Measurement Equipment Lab (PMEL).....	7-39
7.24	CATCODE 219-943, Base Civil Engineer Pavement and Grounds	7-40
7.25	CATCODE 219-944, Base Civil Engineer Maintenance Shop	7-41
	Table 7-39: CATCODE 219-944, BCE Maint Shop, Flying Unit	7-41
	Table 7-40: CATCODE 219-944, BCE Maint Shop, 1/2 RED HORSE Sqd.....	7-42
	Table 7-41: CATCODE 219-944, BCE Maint Shop, 1/4 RED HORSE Sqd.....	7-42
	Table 7-42: CATCODE 219-944, BCE Maint Shop, CRTC	7-43
	Table 7-43: CATCODE 219-944, BCE Maint Shop, FTIG & JCSS	7-43
	Table 7-44: CATCODE 219-944, Prime Power Maint Shop, Designated Units.....	7-44
	Table 7-45: CATCODE 219-944, BCE Maint Shop, ANGR CAMPUS.....	7-44
7.26	CATCODE 219-947, Base Civil Engineer Storage Shed	7-45

Table 7-46: CATCODE 219-947, BCE Storage Shed	7-45
Figure 7-20: CATCODE 219-947, BCE Storage Shed example images	7-45
Chapter 8: Category Group 31 – RDTE Buildings	8-1
8.1 General Criteria.....	8-1
8.2 CATCODE 311-114, Aircraft Dynamic Research Engineering Facility.....	8-1
Chapter 9: Category Group 42 – Explosive Facilities	9-1
9.1 General Criteria.....	9-1
9.2 CATCODE 422-258, Above Ground Multi-Cubicle Magazine Storage	9-1
Table 9-1: CATCODE 422-258, Above Ground Multi-Cubicle Magazine Storage	9-1
9.3 CATCODE 422-264, Storage Igloo.....	9-2
Table 9-2: CATCODE 422-264, Storage Igloo.....	9-2
Figure 9-1: CATCODE 422-264, Storage Igloo example, used for F-15EX	9-2
9.4 CATCODE 422-275, Ancillary Explosives Facility.....	9-3
Chapter 10: Category Groups 44, 45 – Storage Facilities: Covered, Open, Special Purpose.....	10-1
10.1 General Criteria.....	10-1
10.2 CATCODE 442-257, Base Hazardous Materials Storage	10-1
Table 10-1: CATCODE 442-257, HAZMAT Pharmacy	10-1
10.3 CATCODE 442-258, Cryogenics (LOX / LIN) Storage	10-3
10.4 CATCODE 442-628, Base Supply and Equipment Shed	10-4
Table 10-2: CATCODE 442-628, Base Supply and Equipment Shed	10-4
10.5 CATCODE 442-758, Base Supply and Equipment Warehouse	10-5
Table 10-3: CATCODE 442-758, Base Supply and Equipment Warehouse	10-5
10.6 CATCODE 452-252, Base Supply Open Storage	10-7
10.7 CATCODE 452-255, Base Civil Engineer Open Storage	10-7
Chapter 11: Category Group 61 – Administrative Facilities	11-1
11.1 General Criteria.....	11-1
11.2 CATCODE 610-121, Vehicle Operations Administration	11-1
Table 11-1: CATCODE 610-121, Vehicle Operations Admin	11-1
11.3 CATCODE 610-122, Base Supply Administration	11-2
Table 11-2: CATCODE 610-122, Base Supply Admin, Flying Unit, 43 Personnel	11-2
Table 11-3: CATCODE 610-122, Base Supply Admin, KC-135 Two Flying Sqdns, 47 Personnel..	11-4
Table 11-4: CATCODE 610-122, Base Supply Admin, Non-Flying Unit, 18 Personnel	11-5
Table 11-5: CATCODE 610-122, Base Supply Admin, CRTC, 9 Personnel	11-6
Table 11-6: CATCODE 610-122, Base Supply Admin, GSU and 1/2 RED HORSE Sqd, 7 Prsnl ...	11-7
Table 11-7: CATCODE 610-122, Base Supply Admin, 1/4 RED HORSE Sqd, 4 Personnel	11-7
11.4 CATCODE 610-123, General Administrative Building.....	11-8
11.5 CATCODE 610-127, Base Civil Engineer Administration	11-9
Table 11-8: CATCODE 610-127, BCE Admin, Flying Unit with Prime BEEF Team.....	11-9
Table 11-9: CATCODE 610-127, BCE Admin, Flying Unit w/o Prime BEEF Team	11-10
Table 11-10: CATCODE 610-127, BCE Admin, S-Team, 25 Personnel	11-11
Table 11-11: CATCODE 610-127, BCE Admin, S-Team, 40 Personnel	11-11
Table 11-12: CATCODE 610-127, BCE Admin, CRTC, 10 Personnel.....	11-13

Table 11-13: CATCODE 610-127, BCE Admin, BOS w/o Prime BEEF, 7 Personnel 11-14
 Table 11-14: CATCODE 610-127, BCE Admin, ANGRG CAMPUS, 5 Personnel..... 11-15
 11.6 CATCODE 610-129, Weapons Systems Maintenance Management (WSMM) 11-16
 Table 11-15: CATCODE 610-129, Weapons Sys Maint (Fighters), 67 Personnel 11-16
 Table 11-16: CATCODE 610-129, Weapons Sys Maint (F-35 w/o Contractors), 74 Personnel 11-18
 Table 11-17: CATCODE 610-129, Weapons Sys Maint (F-35 w/ Contractors), 84 Personnel 11-19
 Table 11-18: CATCODE 610-129, Weapons Sys Maint (Airlift), 56 Personnel 11-20
 Table 11-19: CATCODE 610-129, Weapons Sys Maint (Tanker), 54 Personnel 11-21
 Table 11-20: CATCODE 610-129, Weapons Sys Maint (MQ-9), 48 Personnel 11-22
 Table 11-21: CATCODE 610-129, Weapons Sys Maint (RPA MCE), 55 Personnel..... 11-23
 11.7 CATCODE 610-287, Specified Headquarters 11-24
 Table 11-22: CATCODE 610-287, Specified HQ, Category A, 20 Personnel 11-24
 Table 11-23: CATCODE 610-287, Specified HQ, Category B, 22 Personnel..... 11-25
 Table 11-24: CATCODE 610-287, Specified HQ, Category C, 25 Personnel..... 11-26
 Table 11-25: CATCODE 610-287, Specified HQ, Guam and Virgin Islands, 10 Personnel 11-27
 11.8 CATCODE 610-811, Administrative Office, Non Air Force 11-28
 11.9 CATCODE 610-913, Emergency Management (EM)..... 11-29
 Table 11-26: CATCODE 610-913, Emergency Management – 7 and 13 Personnel 11-29

Chapter 12: Category Groups 72, 73 – Dining Hall and Quarters, Personnel Support..... 12-1

12.1 General Criteria..... 12-1
 12.2 CATCODE 722-351, Dining & Training Facility 12-1
 Table 12-1: CATCODE 722-351, Dining & Training Facility 12-1
 Table 12-2: CATCODE 722-351, GSU and RED HORSE Dining & Training Facility..... 12-1
 12.3 CATCODE 723-392, Sanitary Latrine 12-2
 12.4 CATCODE 725-517, Troop Camp (Quarters)..... 12-3
 Table 12-3: CATCODE 725-517, Troop Camp Quarters 12-3
 12.5 CATCODE 730-832, Visitor Control Center 12-4
 12.6 CATCODE 730-835, Security Forces Operations 12-5
 Table 12-4: CATCODE 730-835, Security Forces Ops, Stand Alone, 74 Personnel..... 12-5
 Table 12-5: CATCODE 730-835, Security Forces Ops, Stand Alone, 87 Personnel..... 12-6
 Table 12-6: CATCODE 730-835, Security Forces Ops, Stand Alone, 118 Personnel..... 12-7
 Table 12-7: CATCODE 730-835, Security Forces Ops, Collocated, 61 Personnel 12-8
 Table 12-8: CATCODE 730-835, Security Forces Ops, CRTG..... 12-9
 Table 12-9: CATCODE 730-835, Security Forces Ops (Deployed / Visiting Unit - CRTG) 12-9
 12.7 CATCODE 730-837, Security Entry Control Building 12-11
 12.8 CATCODE 730-839, Traffic Gatehouse and Guard Booth 12-12
 Table 12-10: CATCODE 730-839, Traffic Check House (Gatehouse)..... 12-13
 Figure 12-1: CATCODE 730-839, Main Gate Gatehouse detailed layout, in use since 2004 12-13
 Figure 12-2: Guard Booth size based on Army Corps standard and Andrews Guard Booth 12-14
 Figure 12-3: Air Force use of ID Check 6” from edge of curb 12-14
 Figure 12-4: CATCODE 730-839, Guard Booth layout and elevation details, when used 12-14
 Figure 12-5: SDDCTEA Exhibit 1.20: Low Volume ECF with POV Processing and AF Low Volume, for reference 12-15
 Figure 12-6: NGB/A4 SharePoint Find 9 Tool intro and launch page from above link..... 12-15
 Figure 12-7: ANG ECF Template Detailed View separated vehicle inspection 12-16

Figure 12-8: ANG ECF Template Detailed View collocated commercial vehicle inspection 12-17

Figure 12-9: ANG ECF Template two lanes in with separated commercial inspection, use only if a secondary gate is available and can handle oversized vehicles 12-18

Figure 12-10: ANG ECF Template collocated commercial vehicle inspection, use only if a secondary gate is available and can handle oversized vehicles 12-19

Figure 12-11: ANG ECF Template complete layout, use of curves to meet the 9 seconds 12-20

Chapter 13: Category Groups 74, 75 – Morale, Welfare, and Recreation Facilities 13-1

13.1 General Criteria.....13-1

13.2 CATCODE 740-155, Credit Union13-1

13.3 CATCODE 740-389, Exchange Service Outlet.....13-1

13.4 CATCODE 740-674, Physical Fitness13-2

 Table 13-1: CATCODE 740-674, Physical Fitness..... 13-2

13.5 CATCODE 750-177, Athletic Field, Track13-3

 Table 13-2: CATCODE 750-177, Exclusive Use Running Track Options..... 13-3

 Figure 13-1: CATCODE 750-177, Running Track Layout..... 13-4

 Figure 13-2: CATCODE 750-177, Running Track Lane Line Details..... 13-4

13.6 CATCODE 750-371, Recreational Pavilion13-5

 Table 13-3: CATCODE 750-371, Recreational Pavilion 13-5

Chapter 14: Category Group 85, 87, 89 – Roads, Streets, and Utilities..... 14-1

14.1 General Criteria.....14-1

14.2 CATCODE 852-261, Vehicle Parking Operations14-1

 Table 14-1: CATCODE 852-261, Vehicle Parking Operations 14-1

14.3 CATCODE 852-262, Non-Organizational Vehicle Parking.....14-2

14.4 CATCODE 852-263, Vehicle Parking (Unsurfaced).....14-2

14.5 CATCODE 852-269, Refueler Vehicle Parking14-3

 Figure 14-1: CATCODE 852-269, example parking lot for refueling trucks 14-3

14.6 CATCODE 852-273, Aircraft Support Equipment Storage Yard14-4

14.7 CATCODE 872-245, Boundary Fence14-5

14.8 CATCODE 872-247, Security Fence / Vehicle Barriers14-5

14.9 CATCODE 872-248, Fence, Interior14-5

14.10 CATCODE 872-249, Gate, Boundary Fence and Wall14-5

14.11 CATCODE 872-300, Mechanical Security Barricades14-5

14.12 CATCODE 890-181, Utility Line Ducts14-6

Chapter 15: Supplementary Tables for Authorized Functional Areas by Category Code..... 15-1

15.1 Supplementary Tables.....15-1

 Table 15-1: F-15 Fighter Unit 15-1

 Table 15-2: F-15EX Fighter Unit 15-4

 Table 15-3: F-16 Fighter Unit 15-7

 Table 15-4: F-22 Fighter Unit 15-10

 Table 15-5: F-35 Fighter Unit 15-13

 Table 15-6: C-130 Airlift Unit 15-16

 Table 15-7: C-17 Airlift Unit 15-19

 Table 15-8: KC-135-R Refueling Airlift Unit 15-22

Table 15-9: KC-46 Refueling Airlift Unit.....	15-25
Table 15-10: ANG Combat Readiness Training Center (CRTC) Facility Requirements Programming Guide.....	15-28
Table 15-11: ANG RED HORSE Unit Facility Requirements Programming Guide (“1/2 RED HORSE squadron of 210 personnel” and “1/4 RED HORSE of 130 personnel” with equipment and vehicle packages.....	15-31
Table 15-12: ANG 1/2 RED HORSE squadron and 1/4 RED HORSE Assigned Locations.....	15-32
Appendices & References:.....	A
Appendix A: Weapon System / Mission Reference Guides.....	1
A.1 - Stand-Alone Weapon System or Mission.....	2
A.2 - Dependent Weapon System or Mission - High Impact	13
A.3 - Dependent Weapon System or Mission - Low Impact	18
Appendix B: Functional Standards & CATCODE Adjustments	19
B.1 – Functional Standards	20
B.2 – CATCODE Adjustments.....	20
Appendix C: Reference Information.....	21
C.1 - General Criteria.....	22
C.2 - Reference Publications	23
C.3 – List of Figures	26
C.4 - Abbreviations and Acronyms	27
C.5 - Terms	37
Appendix D: USAF comparison to ANG CATCODE Tables.....	41
D.1 - General Criteria	42

Chapter 1: Facility Space Standards

1.1 Purpose

This document provides facility space standards in support of specific mission requirements to meet Air Force and Air National Guard strategic plans and objectives identified in the Infrastructure Investment Strategy and the ANG Infrastructure Strategy. ANG installations are a weapon system, and facilities deliver mission capability. Facility space also has a cost-to-operate and this document empowers users to optimize mission capability with operating cost. This document provides a basis for programming and allocating space for facilities and infrastructure. The authorized space standards also provide a basis for calculating facility operations funding validations. This document also refers to applicable compliance and technical guidance documents. This information serves as a tool in managing real property inventory and optimizing space based on functional need. This Handbook does not address every possible mission or function; however, it does provide instructions on how to request new or revised space requirements in support of assigned or changing missions. Real Property managers must consult with NGB/A4FI for guidance when assigning CATCODEs that are not facility space related.

1.2 Applicability

The functional area standards contained in the Handbook are applicable to the Air National Guard. All space requirements will be programmed based on functional mission requirements, authorized end strength, the quantity and type of authorized mission equipment, and Concepts of Operations (CONOPs).

1.3 Authority

- 1.3.1 NGB/A4F is responsible for validating and updating the content of this Handbook. The Handbook implements: [AFPD 32-10](#), Installations and Facilities; [Title 10 US Code](#), Chapters 1011 and 1803; [Department of Defense \(DoD\) Instruction 4165.03](#), Real Property Categorization, incorporating Change 3, August 31, 2018; [MIL-STD-3007](#) Unified Facilities Criteria, Facilities Criteria And Unified Facilities Guide Specifications; and [UFC-3-101-01](#) Architecture.
- 1.3.2 ANG facility users may request either a variance or modification to an existing Functional Standard or request the creation of a new Functional Standard by following the established procedure outlined in Appendix B - Functional Standards & CATCODE Adjustments Process. NGB/A4F is the approval authority for this process.
- 1.3.3 This Handbook and all users will adhere to federal law and regulations, applicable codes, executive orders, DoD instructions and directives, Air Force and Air National Guard policy, and other standards.

1.4 Handbook Focus

- 1.4.1 This document achieves the following objectives:

- 1.4.1.1 Establishes a process and procedures to collaborate with ANG Functional Area Managers (FAMs) to define and validate space standards for specific mission functions.

1 1.4.1.2 Establish Functional Standards for ANG facilities and areas by defining space based
2 on functional need and by applying consistent administrative standards. Each
3 Category Code (CATCODE) provides a Functional Standard in Gross Square Feet
4 (Gross SF) or Square Yard (SY) to accomplish the mission and incorporate defined
5 mission functions and authorized staffing. The Functional Standard defines the
6 maximum space for a CATCODE at an installation. Functional Standards are
7 developed with FAM collaboration.

8 1.4.1.2.1 Depending on the function, many CATCODEs contain Tables with defined
9 Target Area totals, shown in Net Square Feet (Net SF). The Target Areas
10 identify functional area breakouts and personnel authorizations combined
11 with an overhead factor to define the Functional Standard.

12 1.4.1.2.2 Administrative and common spaces are based on total authorized staffing in
13 the Unit Manning Document (UMD).

14 1.4.1.2.3 Non-administrative space is based on an analysis of mission, function, and
15 published technical guidance. FAM knowledge and professional military
16 judgment are also vital.

17 1.5 **Organization**

18 1.5.1 Chapter 1 contains the framework for understanding and properly implementing the
19 Handbook content. Chapter 1 defines purpose, applicability, authority, definitions, and
20 Functional Standards; and lists reference information, allowing the user to properly address
21 Federal, DoD, USAF, and ANG guidance.

22 1.5.2 Chapters 2 through 13, organized by Category Group, define Functional Standards, arranged
23 by CATCODE, and contain descriptions, functional area breakouts, authorized staffing, and
24 referenced guidance.

25 1.5.3 Appendix A – Weapon System / Mission Reference Guide. Contains summary information
26 that cross references CATCODEs against common weapon systems and mission sets.

27 1.5.4 Appendix B – Functional Standards & CATCODE Adjustments. Summary section and
28 description with link for the Functional Space Standards Management (FSSM) Tool that is
29 only for a CATCODE with 15% or greater increase in UMD or equipment.

30 1.5.5 Appendix C – Reference Information, identifies acronyms and reference documents
31 regarding facility and area design, layout, compliance, and related standards.

32

1.6 **Definitions**

1.6.1 Authorized End Strength: The authorized number of personnel in a unit’s functional area according to the Unit Manning Document (UMD) for a guard drill weekend. Personnel on guard drill weekend are Drill Status Guard (DSG) and Active Guard Reserve (AGR). A Dual Status Technician (DST) has a military DSG position – the DST will show up on the UMD in two places thus only count the DSG position. Only count funded positions. Most of the UMD does count as most are DSG & AGR. See the table below:

Table 1-1: UMD personnel counted in Functional Standards

MNT	MNT Title	RIC	RIC Title	Counted in Functional Standard
XXXXX	FUNDED PERM	0028	ANG OFFICERS 48 DRILL	Yes
RXXXX	UNFUNDED	0028	ANG OFFICERS 48 DRILL	No (unfunded)
XXXXE	OVERHIRE	0028	ANG OFFICERS 48 DRILL	No (over hires)
XXXXX	FUNDED PERM	0034	ANG OFFICERS ACTIVE DUTY	Yes
RXXXX	UNFUNDED	0034	ANG OFFICERS ACTIVE DUTY	No (unfunded)
XXXXX	FUNDED PERM	0036	GUARD OFFICER TRAINING PIPELINE	No (Student Flight)
XXXXX	FUNDED PERM	0127	INIT ACTIVE DUTY FOR TNG - ANG	No (Student Flight)
XXXXX	FUNDED PERM	0128	ANG AIRMEN 48 DRILL	Yes
RXXXX	UNFUNDED	0128	ANG AIRMEN 48 DRILL	No (unfunded)
XXXXE	OVERHIRE	0128	ANG AIRMEN 48 DRILL	No (over hires)
XXXXX	FUNDED PERM	0148	ANG ENLISTED ACTIVE DUTY	Yes
RXXXX	UNFUNDED PERM	0148	ANG ENLISTED ACTIVE DUTY	No (unfunded)
XXXXX	FUNDED PERM	0160	CIVILIANS UNITED STATE DIRECT HIRE (USDH)	No (Title 5, if there is a 15% Guard Drill Weekend increase then submit for a new Functional Standard)
RXXXX	UNFUNDED PERM	0160	CIVILIANS UNITED STATE DIRECT HIRE (USDH)	No (unfunded)
XXXXX	FUNDED PERM	0170	CIV NATL GRD TECHS (MEMO)	No (DST already counted in military position thus does not count twice)
RXXXX	UNFUNDED PERM	0170	CIV NATL GRD TECHS (MEMO)	No (unfunded)
XXXXX	FUNDED PERM	0181	GUARD ENLISTED TNG PIPELINE PAID	No (Student Flight)
NXXCX	NON-FYDP CONTRACTOR	8888	CONTRACTOR	No (state employees or contractor, if there is a 15% Guard Drill Weekend increase then submit for a new Functional Standard)

1.6.2 Category Code: Referred to as CATCODE in this Handbook, there are six-digit identifiers for each type of mission element in the ANG built infrastructure. The applicability of any CATCODE for ANG mission is subject to NGB/A4F approval.

1.6.3 Category Group: The aggregation of one or more real property CATCODEs that have a like functional purpose and are measured in the same units. Each Category Group is identified by a two-digit designation that corresponds to the first two digits of the CATCODEs within the group. The Category Group is not used for real property classification.

1.6.4 Facility Analysis Category (FAC): A classification of real property types within a “Basic category”, represented by a four-digit code. DoD FACs aggregate Military Department

- 1 categories into common groupings based upon commonality of function, unit of measure,
2 and unit costs.
- 3 1.6.5 Facilities Board (FB): The ANG installation’s corporate decision-making body for real
4 property (RP) and facility actions is chaired by the Installation Commander. All RP and
5 facility actions require the support and approval of the Facilities Board (FB) or similar
6 committee. Previously known as the Facilities Utilization Board (FUB), the FB is
7 established in ANGI 32-1003, Facilities Board.
- 8 1.6.6 Functional Area Manager (FAM): The FAM is the individual responsible for the
9 management and planning of all personnel and equipment within a specific functional area
10 to support wartime contingencies, peacetime contingencies, and authorized staffing.
- 11 1.6.7 Functional Standard: The defined space standard for a CATCODE. The Functional
12 Standard assigned to a CATCODE typically consists of a compilation of the functional and
13 breakout area totals, authorized staffing if applicable, and combined with an overhead
14 factor. The unit of measure is Gross Square Feet (Gross SF) or Square Yards (SY).
- 15 1.6.8 Northern Tier: For applying Handbook criteria, Northern Tier installations are defined as
16 those experiencing 30 or more days per year of minus 12 ° C (10° F) or lower, or with an
17 average January temperature of minus 7° C (20° F) or lower (see Table 1-2), determined
18 from two 10-year (or longer) weather databases. This information may be obtained from a
19 number of sources including:
- 20 1.6.8.1 National Oceanic and Atmospheric Administration’s (NOAA) National Weather
21 Service (NWS)
- 22 1.6.8.2 AccuWeather
- 23 1.6.8.3 Weather Source / Weather Warehouse
- 24 1.6.8.4 WeatherBank
- 25

1

Table 1-2: ANG Northern Tier Locations per 2022 NWS NCEI data

SiteID	Installation Name	Wing	City	State	10 Year January AVG (°F)
FXSB	JB Elmendorf-Richardson	176 WG	Anchorage	AK	10.2
FTQW	Eielson AFB	168 ARW	Fairbanks	AK	-16.4
DXEB	Clear SFS	168 ARW	Anderson	AK	-16.4
JMAX	Greeley ANGS	140 WG	Greeley	CO	12.9
FFAN	Des Moines IAP	132 WG	Des Moines	IA	17
VSSB	Sioux Gateway Apt	185 ARW	Sioux City	IA	13.7
HEMT	Fort Dodge ANGS	185 ARW	Fort Dodge	IA	11.9
JLQN	General Wayne Downing Peoria IAP	182 AW	Peoria	IL	19.4
AXQD	Barnes MAP	104 FW	Westfield	MA	18.9
VVRK	South Portland ANGS	101 ARW	South Portland	ME	18.1
FKNN	Bangor IAP	101 ARW	Bangor	ME	11.9
MBMW	MI JF HQ	State HQ	Lansing	MI	19.3
CYTL	Camp Grayling Weapons Range	CRTC-MI	Grayling	MI	14.2
TDVG	Alpena County RAP	CRTC-MI	Alpena	MI	13.6
QJKL	Minneapolis-St Paul IAP	133 AW	St Paul	MN	10.5
FMKM	Duluth IAP	148 FW	Duluth	MN	4
ULYB	Rosecrans Memorial Apt	139 AW	St Joseph	MO	20
JKSE	Great Falls IAP	120 AW	Great Falls	MT	19.1
NZAS	Malmstrom AFB	120 AW	Great Falls	MT	18.3
MAGS	Minot ANGS	119 WG	Minot AFB	ND	7.2
QJVF	Minot AFB	119 WG	Minot	ND	7.2
KKGA	Hector IAP	119 WG	Fargo	ND	3.3
JFSD	Grand Forks AFB	119 WG	Emerado	ND	-0.4
NGCB	Lincoln Apt	155 ARW	Lincoln	NE	16.8
VBDZ	Schenectady CAP	109 AW	Schenectady	NY	19.1
HAAW	Syracuse Hancock IAP	174 ATKW	North Syracuse	NY	18.1
GRCL	Griffiss ANGS	174 ATKW	Rome	NY	14
FPBB	Fort Drum	174 ATKW	Fort Drum	NY	11.6
LUXC	Joe Foss Field	114 FW	Sioux Falls	SD	10.9
CURZ	Burlington IAP	158 FW	South Burlington	VT	14.4
HTUV	General Mitchell IAP	128 ARW	Bay View	WI	18.9
XGFG	Dane County RAP - Truax Field	115 FW	Madison	WI	13.5
YAQF	Volk Field	CRTC-WI	Camp Douglas	WI	9.6
GRAE	Hardwood Weapons Range	Range WI	Finley	WI	9.6
DPEZ	Cheyenne ANGB, Cheyenne Regional Airport	153 AW	Cheyenne	WY	18

2

1 1.6.9 Target Area: The estimated optimum space for a specific area or mission subset within a
2 CATCODE. The unit of measure is Net Square Feet (Net SF). The overall Functional
3 Standard for each CATCODE, after overhead is applied, is expressed in Gross Square Feet
4 (Gross SF), see [Gross Area](#) and [Net Square Feet](#) definitions. Also see Section [1.9 Scope](#)
5 [Calculations](#) for clarification.

6 1.6.10 Variance: An approved addition or subtraction to the CATCODE Functional Standard. A
7 Variance will identify adjustment to a standard, unique to a mission or installation, based on
8 circumstances such as staffing, equipment and / or mission changes. It can also result in a
9 modification to the Functional Standard if it applies to the entire ANG. The process to
10 request, validate and approve a CATCODE Adjustments is outlined in Appendix B.

11 1.7 Administrative Area Standards

12 1.7.1 This Handbook defines ANG Functional Standards for all facilities and spaces. A large
13 portion of most Functional Standards include administrative, training, testing, and meeting
14 spaces within a facility, based on the mission or functional requirement.

15 1.7.2 Functional Standards other than administrative, typically shop, hangar, and material storage
16 spaces are defined within the respective CATCODE and based on function and / or
17 equipment requirements.

18 1.7.3 Administrative area standards provide a planning guide for local leadership to allocate
19 reasonable space in support of functional requirements through established procedures, i.e.,
20 Facilities Board (FB), Design Working Group (DWG) and Commander's local authority.
21 Size, space layout and related administrative area preferences can be assessed and defined to
22 accommodate functional area priorities.

23 1.7.4 Conference and meeting space does not necessarily accommodate the total authorized
24 staffing of any CATCODE function, as ANG installations typically have facility open
25 spaces (dining facility, large squadron meeting rooms, and open hangar floor) capable of
26 accommodating unit assemblies.

27 1.7.5 Administrative areas shall maximize open space concepts using systems furniture (and / or
28 demountable partitions) to achieve efficient and flexible operations. This Handbook
29 supports a space optimization objective and minimizes enclosed office spaces.

30 1.7.6 The following categories define ANG administrative target areas used to compute
31 CATCODE Target Area Net Square Feet (SF):

32 1.7.6.1 Administrative Work Areas: Table 1-1 defines target space, in net SF, for individual
33 and staff functions.

1 **Table 1-3: Administrative Work Areas**

Category Title	Category Functions	Target Area (Net SF)	Remarks / Rationale
Senior Commander	ANG State Command, Wing Command	240	Space to accommodate small group discussion
Vice Commander / Group Commanders	Wing Command and Group Command	160	Space to accommodate staff / visitors
Sensitive Functional Position	JAGs, Chaplains & 1 st Sergeants (typical), Squadron & Flight Command	120	Predicated on the specific functional requirement
Functional Administrative Positions	Supervisory, Administrative and Technical	64	Workstation, open environment, typically 6x8' (48 SF) cubicle (64 SF accounts for circulation) (see Figure 1-1)
Operations Floor	Aviation, Space, Security, and Intel type Operations Centers	42	Multiple personnel in side-by-side desks facing flat panel screen systems, typical 5'x2' desk with chair movement and circulation for 42 SF (see Figure 1-2)
Non-permanent Assigned Individuals / Non-Administrative Position	Shared Computer Access at 25% to 50% of planned users. This is used for users that typically work in a different area and only need occasional access	24	Typical 3x4' (12 SF) workstation (24 SF accounts for chair movement and circulation) for 2 to 4 personnel shared use as Hoteling, Training Station, CBT, visiting IG, exercise-related functions, etc. (see Figure 1-1)

2 **Figure 1-1: Typical Cubicle and Hoteling, the 64 SF and 24 SF, including circulation**

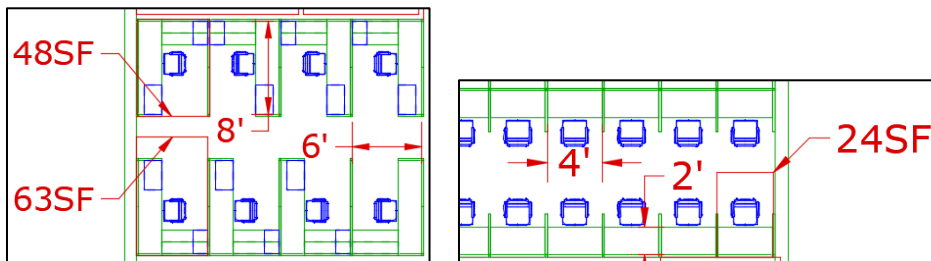

3
 4 **Figure 1-2: Typical Operations Floor, 42 SF includes circulation and NIPR/SIPR separation needs**
 5

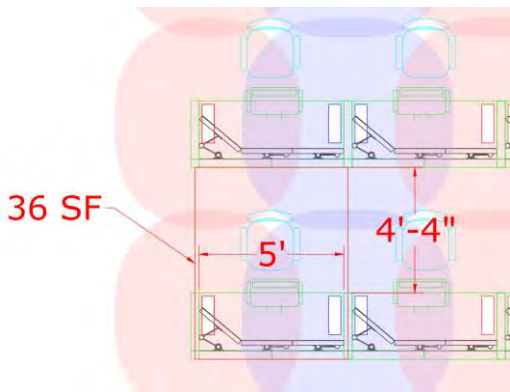

6
 7 1.7.6.1 **Table 1-4** defines Typical Assembly Space in square feet per person that includes
 8 both the seating area and space necessary for aisle-ways/circulation. Graphics below
 9 are from ANG project submittals and match the planning factors.

1 **Table 1-4: Typical Assembly Space**

Description	Planning Factor
Conference Room (13 to 30)	15 sq. ft. per person
Conference Room (6 to 12)	20 sq. ft. per person
Classroom	25 sq. ft. per person including student desk and instructor area
Assembly/Auditorium	10 sq. ft. per person

2 **Figure 1-3: Typical Assembly Space and Conference Room Space**

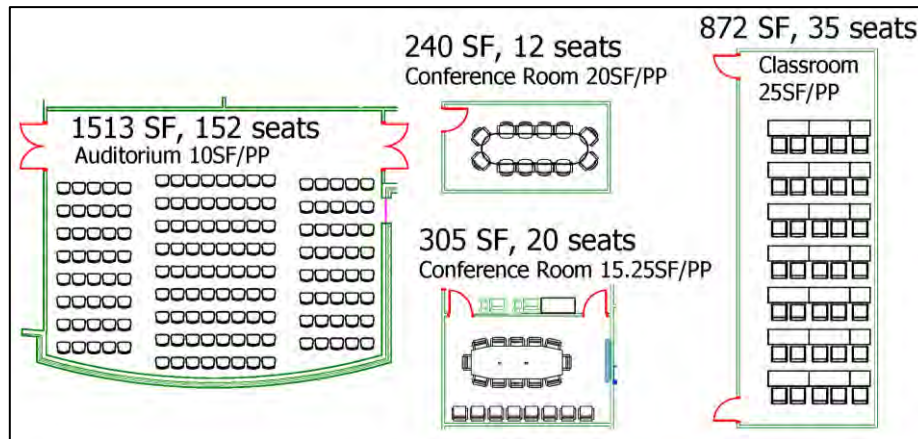

3
 4

1.7.6.2 Conference and Meeting: Table 1-3 defines CATCODE net square feet target area for conference and meeting areas, developed as a percentage of the authorized staffing, (SF/Person shown as multiplier factor).

Table 1-5: Conference and Meeting Space

Authorized Staffing	50% of Authorized	Target Area (Net SF)	SF/ Person
Up to 25	13	260	20
26 - 49	25	450	18
50 - 74	37	590	16
75 - 99	50	700	14
100 - 124	62	740	12
125 - 149	75	830	11
Over 150	90	900	10

1.7.6.3 **Table 1-4** defines CATCODE net square feet target area for classroom and testing space, including computer stations, developed as a percentage of the authorized staffing, (SF/Person shown as multiplier factor).

Table 1-6: Training and Testing Space

Authorized Staffing	25% of Authorized	Target Area (Net SF)	SF / Person
Up to 25	6	120	20
26 - 49	12	220	18
50 - 74	19	300	16
75 - 99	25	350	14
100 - 124	31	400	13
125 - 149	37	440	12
Over 150	45	500	11

1.7.7 Unless otherwise noted, the Functional Standards shown throughout this Handbook are based on the UMD for a given mission set. Increases in manning or installation population, not provided on a UMD, should not be used as the justification for larger facilities.

1.7.7.1 Authorized staffing includes all mission personnel identified on the UMD, supporting agencies, and transient personnel.

1.7.7.2 When the installation regularly serves a substantial number of military transients, the average daily strength, based on a firm projection of the total yearly load, may be added to the projected authorized staffing strength of the installation. This applies to certain CATCODEs that rely on the UMD for the Functional Standard.

1 1.7.8 Approved manpower increases do not automatically justify an increase in a Functional
 2 Standard. A 15% increase or higher in authorized staffing or equipment is the lower
 3 threshold that triggers a justification for submitting a New Functional Standard & Variance
 4 Request provided that space optimization has already occurred and still negatively impacts
 5 the mission. Finally, the Concept of Operations (CONOPs) will also be evaluated when
 6 considering a space increase due to manpower increases.

7 **1.8 Overhead Factor**

8 1.8.1 The calculation to identify CATCODE overhead space incorporates facility features
 9 typically integrated within the Functional Standard. The amount of overhead space is
 10 determined by multiplying the CATCODE Target Area (Net SF) Subtotal by the identified
 11 overhead percentage for the facility function(s).

12 1.8.2 Overhead Percentage: The following criterion, as seen in Table 1-4, determines the
 13 respective overhead factor:

14 1.8.2.1 For administrative functions consisting of a single CATCODE or the administrative
 15 CATCODE resides in a multi-functional facility, the overhead factor is 25%.

16 1.8.2.2 For industrial functions / facilities, aircraft hangars, maintenance facilities, storage
 17 facilities, etc., the overhead factor is 15%.

18 1.8.2.3 For collocated similar facility functions, whereby the specific CATCODE function is
 19 located within and subordinate to a larger functional area, and does not require facility
 20 expansion, the overhead factor is 10%.

21 1.8.2.4 Several intended collocated CATCODEs may be grouped together. Designate one of
 22 the collocated as the predominant CATCODE and apply the 25% overhead factor for
 23 administrative CATCODEs or the 15% overhead factor for industrial CATCODEs.

24 1.8.2.5 CATCODEs intended to be collocated are already identified with a 10% overhead
 25 standard in the appropriate CATCODE table.

26 1.8.2.6 Construction of an intended collocated CATCODE as a stand-alone facility will not
 27 change the overhead percentage to 25%, unless otherwise noted.

28 1.8.2.7 For facilities housing collocated (similar or non-similar) functions, the combined
 29 facility overhead factor will not exceed 25%.

30 **Table 1-7: Facility Function Overhead Percentage**

Facility Function	Overhead Factor
Administrative	25%
Industrial & Warehouse	15%
Collocated (Similar Function)	10%

1.8.3 Overhead Components: Depending on the facility function, several or all of the following features will be included in the overhead calculation for the respective CATCODE:

1.8.3.1 Building hallways, vestibules, and lobbies.

1.8.3.2 Mechanical, electrical, plumbing, communications equipment rooms, and access.

1.8.3.3 Communications equipment (reference UFC 3-580-01 and ETL 02-12).

1.8.3.4 Restrooms and personnel lockers.

1.8.3.5 Wall thickness.

1.8.3.6 Custodial supplies and equipment storage.

1.8.3.7 Administrative support space (copy / repro, supplies and document storage).

1.8.3.8 Vertical penetrations for each floor level they occupy (stairs, elevator shafts, flues, pipe shafts, vertical ducts).

1.9 Scope Calculations

1.9.1 Functional Standards for CATCODEs are expressed in terms of gross square feet (Gross SF), unless otherwise noted, and define the maximum space to perform the respective functions. Gross area is computed to the outside of exterior walls. Various facility components, identified below, will be calculated as full scope, i.e., the actual measured area, or something less than full scope. Reference UFC 3-101-01 Architecture, Building Area Calculations.

Table 1-8: Example Scope Calculations

Example Building Areas	Scope SF	Functional Standard SF
First Floor 40 ft by 40 ft measured from wall exteriors and includes a 10 ft by 40 ft atrium	1,600	1,600
Second Floor 30 ft by 30 ft measured from outside walls, center of mechanical mezzanine wall, and to the atrium empty space. The atrium void above the first floor is excluded from the area calculation.	900	900
Second Floor mechanical mezzanine of this building measured 30 ft by 10 ft	300	300
Square Full Basement of this building is 40 ft by 40 ft measured from wall exteriors	1,600	1,600
Enclosed attached stairwell 10 ft x 10 ft (exterior dimensions) provides vertical circulation between the basement, first, and second floors, adding 100 GSF per occupied level, for a total of 300 SF.	300	300
Covered exterior stairwell 10 ft x 10 ft (measured by its footprint) provides vertical circulation between the basement, first, and second floors, adding 50 GSF per occupied level, for a total of 150 SF.	150	150
Uncovered exterior stairwell 10 ft x 10 ft (measured by its footprint) provides vertical circulation between the first and second floors, adding 50 GSF per occupied level, for a total of 100 SF. Covered and uncovered but not enclosed exterior stairs covered and uncovered are One-Half Space or 50% scope.	100	100
10 ft by 10 ft covered entry to first floor, roof area 100 SF, first floor assigned 50 SF (covered entry is half scope)	50	50
Total Scope and Total Functional Standard Square Footage	5,000	5,000

1.9.2 Full Scope Space: Basements; above-grade floors; mezzanines (regardless of height); all mechanical areas are Full Scope unless otherwise approved from NGB/A4F; penthouses; interior stairs, elevators, and utility chases for each floor level they occupy; fully enclosed balconies; covered storage facilities, vertical penetrations, covered and enclosed passages / walks and door pockets for aircraft hangars. The un-enclosed shed, overhead protection,

- 1 and recreational pavilion are counted as full scope. Example of un-enclosed CATCODEs
2 that are full scope:
- 3 1.9.2.1 CATCODE 145-921, Overhead Protection, full scope
 - 4 1.9.2.2 CATCODE 214-428, Vehicle Operations Parking Shed, full scope
 - 5 1.9.2.3 CATCODE 442-628, Base Supply and Equipment Shed, full scope
 - 6 1.9.2.4 CATCODE 219-947, Base Civil Engineer Storage Shed, full scope
 - 7 1.9.2.5 CATCODE 750-371, Recreational Pavilion, full scope
- 8 1.9.3 Half-Scope Space: Covered, but not fully enclosed, walkways, ramps, porches, and
9 balconies. Exterior stairways (covered and uncovered). Covered raised loading platforms.
10 Covered ground level or depressed loading facilities. These spaces are categorized as
11 occasional use, non-storage spaces.
- 12 1.9.4 Excluded Space from Scope: Minor roof overhangs; utility tunnels, crawl spaces, and
13 catwalks with ceiling heights less than 7 feet; exterior uncovered walkways, ramps,
14 balconies, and paved pad / patios / terraces.
- 15 1.9.5 Gross square feet functional standards assume a nine to twelve-foot floor to finished ceiling
16 (not Structure) clear height for most administrative spaces and a twelve-foot floor to ceiling
17 clear height for most industrial spaces (finished ceiling or bottom of structure). Supply
18 warehouse floor to ceiling clear height assumption is twenty-five feet. Aircraft hangar
19 ceiling heights will vary according to the aircraft requirements.
- 20

1.10 Aircraft Authorization Planning Factors

1.10.1 Many CATCODEs and tables in this Handbook are based on a standard Primary Aircraft Authorization (PAA). Table 1-7 shows the ANG mission aircraft and the PAA Planning Factor used to calculate Functional Standards.

Table 1-9: PAA Planning Factors

Aircraft / Mission	Remarks
A-10 / F-15 / F-16	1 - 24 PAA
F-22 / F-35 / F-15EX	1 - 18 PAA
C-17	1 - 8 PAA
C-38 / C-40	C-38: 1 - 2 PAA / C-40: 1 - 3 PAA
C-130	1 - 12 PAA
KC-46A	1-12 PAA
KC-135, One Flying Squadron	1 - 12 PAA
KC-135, Two Flying Squadrons	13 - 18 PAA
MQ-9 Reaper	1 - 18 PAA
Rescue	HC-130: 1 - 4 PAA / HH-60: 1- 5 PAA
MC-12	1-18 PAA

1.10.2 Any ANG unit exceeding the PAA for the weapons system listed in Table 1-7 will have a custom Functional Standards existing or will have NGB/A4 Basing and Requirements work to get custom Functional Standards. An example would be FTU locations.

1.11 Physical Fitness Areas

1.11.1 Dedicated physical fitness space is only authorized at ANG installations under the following CATCODES:

1.11.1.1 [CATCODE 740-674, Physical Fitness](#)

1.11.1.2 [CATCODE 130-142, Aircraft Rescue Fire Fighting \(ARFF\) Station](#)

1.11.1.3 [CATCODE 750-177, Exclusive Use Running Track](#)

1.11.1.4 [CATCODE 171-618, Field Training Facility, Battlefield Airmen Gym, ASOS](#)

1.11.1.5 [CATCODE 141-459, Crew Readiness](#)

1.11.2 Inclusion of physical fitness space within a facility assigned to any other CATCODE will result in a redistribution of fitness space within [CATCODE 740-674, Physical Fitness](#).

1.12 Personal Mobility Equipment

- 1.12.1 Storage of installation's deployable personal mobility equipment is included in [CATCODE 442-758, Base Supply and Equipment Warehouse](#) unless otherwise indicated in another table.
- 1.12.2 Training Personal Mobility Equipment is stored at squadron or flight unit level, in the individual CATCODEs unless otherwise indicated. Space is calculated at 1.5 SF per mobility position (exception is Security Forces which is calculated at 3 SF per mobility position).
- 1.12.3 The inclusion of deployable mobility storage space within a facility of any other CATCODE will result in a redistribution of storage space from [CATCODE 442-758, Base Supply and Equipment Warehouse](#).

1.13 Lactation Rooms for Nursing Mothers

- 1.13.1 At installation level there could be one, two, or no Lactation Room(s) needed, and there could be a temporary need. The responsibility has been delegated to unit level commanders to manage IAW DAFI36-3013 which also outlines distance between buildings as can have a shared room plus Lactation Room requirements.
- 1.13.2 Must use existing CATCODE Admin space as there is no square footage assigned and no separate CATCODE assigned.

1.14 How To Use this Handbook

- 1.14.1 Document Readability and Usability: The document allows for easy navigation between the Table of Contents and each CATCODE and Appendices via hyperlinks.

1.14.1.1 Begin by installing the 'Back' button on the Microsoft Word Quick Access Toolbar (upper left hand).

1.14.1.1.1 Right click anywhere in the Quick Access Toolbar.

1.14.1.1.2 Click on 'Customize Quick Access Toolbar'.

1.14.1.1.3 Open the 'Choose Commands From' drop-down box.

1.14.1.1.4 Select 'All Commands'.

1.14.1.1.5 Scroll down and select the 'Back' button and press 'Add'.

1.14.1.1.6 Press 'Okay'.

1.14.1.1.7 The 'Back' button will appear subdued on the Quick Access Toolbar.

1.14.1.1.8 The 'Back' button will not become active (green) until the user initially navigates from one area of the Handbook to another.

1.14.1.2 To navigate from the Table of Contents to any Chapter or CATCODE table, place the mouse cursor over the desired target, press the 'Control' key and left click with the

1 mouse (Control + Click). To go back to the Table of Contents, go up to the Quick
2 Access Toolbar and click on the green 'Back' button.

3 1.14.1.3 Some CATCODE descriptions have references to other CATCODES and are
4 hyperlinked. To navigate these links, simply Control + Click on the link. To return to
5 the previous CATCODE or paragraph, click on the green 'Back' button. You may
6 navigate throughout the document in this manner and the 'Back' button will work all
7 the way back to the original starting point.

8 1.14.2 Navigation of the document also works in Adobe portable document format (.pdf) file,
9 whether on a desktop, laptop or tablet.

10 1.14.2.1 Click on any line in the Table of Contents, or any CATCODE references within a
11 paragraph, and the document will navigate to that paragraph or table just as in
12 Microsoft Word.

13 1.14.2.2 To return to the previous spot in the document, press 'Alt' + 'Back Arrow'.

14 1.14.3 Applying this Handbook to the ANG programming process:

15 1.14.3.1 Programming consists of the research, planning and decision-making process that
16 identifies the scope of work to be accomplished. This Handbook provides installation
17 leadership, their consultants and ANG Facility Programmers a tool to apply consistent
18 facility space standards across the ANG.

19 1.14.3.2 This Handbook does not provide criteria for the design process. The document
20 identifies Functional Standards focused on optimizing ANG facilities. Appendix C
21 provides applicable Unified Facilities Criteria (UFC), Air Force, ANG, Federal
22 Aviation Administration (FAA), and DoD directives and standards for executing the
23 design process.

24 1.15 **Functional Standards & CATCODE Adjustments (Appendix B):**

25 1.15.1 The CATCODE Functional Standards contained herein adequately accommodate the
26 majority of ANG missions, in some cases where a 15% or greater UMD or equipment
27 increase is identified and validated then can request an adjustment to the CATCODE as
28 outlined in Appendix B.

29 1.15.2 The FAM is both integral and responsible for verifying that required justifications and
30 documentation have been provided with the request.

31 1.15.3 Complete request routing is through A4FD, A4FR and to A4F for approval or disapproval.
32 Only the A4F makes square footage changes.

1 1.16 **Responsibilities**

2 1.16.1 NGB/A4F: Coordinate with OPRs and FAMs, administer and update this Handbook as
3 current missions change, new missions emerge, and old missions retire; and manage the
4 Functional Standards & CATCODE Adjustments Process as described in Appendix B.

5 1.16.2 FAMs: Provide NGB/A4F with current information in relation to their associated weapon
6 system or mission in order to maintain appropriate spaces aligned to Functional Standards.

7 1.16.3 Installation / Organization Command: Ensure compliance with the Handbook criteria and
8 guidance in optimizing ANG facility spaces to meet functional mission requirements.

Chapter 2: Category Group 11 – Airfield Pavements

2.1 General Criteria

- 2.1.1 The airfield is that portion of an air base used for aircraft taxiing, takeoffs, landings, servicing, and parking. The designation ‘airfield pavements’ applies to runways, taxiways, aprons, arm / disarm pads, paved shoulders, and paved overruns.
- 2.1.2 Airfield Planning Criteria: UFC 3-260-01 always applies to ANG airfield planning criteria. For FAA controlled airfields the UFC subjugates itself to the applicable FAA Circulars (See UFC 3-260-01 to determine the required planning references).
- 2.1.2.1 ANG operations at an airfield with ANG owned runways will apply Air Force standards described in UFC 3-260-01.
- 2.1.2.2 ANG operations at an airfield with Air Force owned runways will apply Air Force standards described in UFC 3-260-01.
- 2.1.2.3 ANG operations at an airfield with Army owned runways will apply Army standards described in UFC 3-260-01. Contact NGB/A4F regarding Army waivers regarding RPA airfield planning criteria.
- 2.1.2.4 ANG operations at an airfield with Navy owned runways will apply Navy standards described in UFC 3-260-01.
- 2.1.2.5 ANG Operations at an airfield with National Aeronautical and Space Administration (NASA) owned runways will apply standards defined specifically by NASA under the authority of The National Aeronautics and Space Act of 1958 (Pub. L. 85–568). NASA has informed ANG their planning factors match those of the FAA.
- 2.1.3 ANG operations at an airfield with FAA controlled runways will apply FAA Criteria Advisory Circular (AC) 150/5300-13A, *Airport Design, to Airfield Pavements* that are jointly used by military and civilian aircraft. Facilities for military use only, such as aircraft parking aprons, taxiways, arresting barriers, arm / disarm aprons, must apply UFC 3-260-01.
- 2.1.4 NGB may approve upgrades to facilities at commercial or FAA airfields in order to meet military requirements of the ANG aircraft operating at the installation.

2.2 CATCODE 111-111, Runway

- 2.2.1 Description: The runway is the paved surface provided for normal aircraft takeoffs and landings. This CATCODE also includes the runway’s grading and drainage, lateral safety zones, and clear zones (see UFC 3-260-01).
- 2.2.2 Runway dimensions and construction shall be sufficient to accommodate all assigned or programmed aircraft. Standards for minimum runway length and width are defined below for the identified aircraft type (see also UFC 3-260-01).
- 2.2.3 The required runway length is determined by the longer of the takeoff distance and the landing distance needed for the aircraft. The designer of the runway shall coordinate with the NGB/A3 (Air, Space and Information Operations Directorate) on the most accurate and economical methods to determine individual runway lengths, based on the aircraft each base supports. The authorized length of a runway also depends on the aircraft assigned and / or programmed for the base as seen in Table 2-1.

Table 2-1: CATCODE 111-111, Minimum Runway Lengths for Fully Loaded Mission Aircraft

Aircraft Type	Minimum Runway Length (ft.)	Runway Width (ft.)
MQ-1	5,000	75
MQ-9	8,000	75
A-10, F-15, F-16, F-22, F-35, C-130	8,000	150
C-17, KC-10, KC-46, KC-135	10,000	150

- 2.2.4 Runway Clear Zone: Runway clear zones are ground areas required at both ends and alongside each runway as seen in Table 2-2 (and UFC 3-260-01 for runway clear zone layout configurations permitted land uses within the clear zone). Projects should be programmed to eliminate all airfield waivers.

Table 2-2: CATCODE 111-111, Runway Clear Zone, Ends of Runway & Centerline

Clear Zone Length (ft.)	Clear Zone Width (ft.)
3,000 ft. See Note 1	3,000 ft. See Note 2

NOTES:

- 1. Full-length runway overrun extends 1,000 ft. into clear zone at runway ends.
- 2. Centered on, and measured at right angles to, runway overrun

2.3 CATCODE 111-115, Paved Overrun

Description: The runway overrun is an extension of the runway pavement (excluding shoulders) designed for possible short landings, unobstructed run-out of aircraft arresting systems, or any other extended takeoff run or landing rollout situation that would exceed the length of the basic runway as seen in Table 2-3 (and UFC 3-260-01).

Table 2-3: CATCODE 111-115, Paved Overrun

Runway Type	Overrun Length	Overrun Width
Heavy, modified heavy, medium-light, auxiliary	1,000 ft. (at each end of runway)	Equal to runway
Short Field Take-off and Landing Zone	300 ft. (at each end of runway)	Equal to runway
RPA (LRE)	300 ft. (at each end of runway)	Equal to runway

2.4 CATCODE 112-211, Taxiway

Description: Taxiways are the pavements provided for the ground movement of aircraft as seen in Table 2-4. They connect the parking and maintenance areas of the airfield with the runways, as well as provide access to hangars, docks, and various parking aprons and pads. Main taxiways are normally aligned parallel to runways to facilitate aircraft ground movement during takeoffs and landings on the runway. Taxiways are authorized on an aircraft-by-aircraft basis, based on the minimum operational requirement. At FAA airfields, taxiways owned by the ANG are exclusive use.

Table 2-4: CATCODE 112-211, Taxiway

Taxiway Class	Taxiway Width (ft.)
Heavy, modified heavy, med-light, auxiliary	75
RPA	50 with 70 turning radius
Short Field Take-off and Landing Zone	30 with 70 turning radius (C-130) and 60 with 116 turning radius (C-17)
Towed aircraft only	Lesser of 50 , or outside landing gear width +10

2.5 CATCODE 113-321, Apron

- 2.5.1 Description: Aprons are paved areas provided for aircraft parking, servicing, loading, and unloading. Apron space is required for operational aircraft, alert aircraft, and cargo aircraft. For proper aircraft apron sizing contact NGB/A4F. The active-duty Air Force criteria should be followed but omit apron space for transient aircraft unless an exception is approved by NGB/A4F.
- 2.5.2 Apron Size / Configuration: There is no standard apron size. Aprons are individually designed to support certain aircraft and missions at specific installations. The size, type, and number of aircraft that require parking determine detailed dimensions. Apron thickness of concrete should be designed to classification of assigned aircraft. The thickness should not vary across the width or length of the Apron including aircraft movement or taxi lane areas for ease of design and construction.
- 2.5.3 Apron Allowances: A proper apron allowance is the amount of space required to afford maximum operational efficiency with the minimum amount of paving. On a typical apron, aircraft are parked in rows and spaced according to the dimensions referenced in Table 2-5 and UFC 3-260-01, which permits the aircraft to move in and out of parking slots under their own power and without any additional safety considerations.

Table 2-5: CATCODE 113-321, Aircraft Dimensional Criteria

Aircraft See Note 1	Wingspan (ft.)	Length (ft.)	Tail Height (ft.)	Fuselage Height (ft.)	Min. Dist. between wings parked aircraft (ft.) See Note 2 & 6
A-10	57.5	53.3	14.9	n/a	10
F-15 / F-15EX	42.8	63.8	19.2	n/a	10
F-16	32.8	47.6	16.4	11.3	10
F-22	44.5	62.1	16.6	n/a	10
F-35	35	51.5	14.2	n/a	10
C-17	170	174	55.1	n/a	25
C-21	39.5	48.6	12.25	n/a	10
C-130	132.6	97.8	38.5	16.1	20
C-130J	132.6	112.8	38.9	16.1	20
C-38A	54.6	55.6	18.2	n/a	10
C-40C	117.4	110.3	41.2	n/a	20
HH-60G	53.7	64.9	16.7	n/a	107.4 See Note 3
KC-135R	130.8	136.2	41.7	17.8	50
KC-46	156.1	165.5	52.9	24.6	50
MC-12	57.9	46.7	14.3	n/a	10
Predator / MQ-1	55.25	27	6.9	n/a	10
Reaper / MQ-9 (See Note 5)	65.6	37.2	11	n/a	10

NOTES:

1. Dimensions vary for different models and configurations of aircraft.
2. Does not apply during contingencies or if aircraft are parked in shelters; see current aircraft T.O.
3. Minimum distance between centerline of parked aircraft (Represents two rotor diameters).
4. Confirm with NGB/A4F dimension planning factors for airframe. Subject to Air Force acquisition efforts.
5. Explosive Quantity distance requirements may dictate a greater minimum separation distance between aircraft. Contact your Wing Weapons Safety Manager.

2.5.3.1 Primary Aircraft Authorization (PAA): Operational aircraft are parked on aprons, strip aprons, or (where authorized) on dispersed stubs. To determine how many operational aircraft require apron space, begin with 100 percent of the PAA as established by official documents (see exceptions in paragraph 2.5.3.2 for AMC aircraft); then subtract: a) the number of aircraft (such as alert aircraft) parked on separate aprons, b) the number of aircraft in maintenance hangars or docks under normal maintenance schedules, and c) any aircraft parked elsewhere on existing pavement of a suitable nature and location. The Predator and Reaper missions only require one parking location per assigned orbit.

2.5.3.2 Parking for all large AMC Aircraft (e.g., C-17, C-130, KC-135, KC-46 and like-size aircraft) requires apron parking spots for the difference between PAA and the number of covered maintenance spaces. While the standard calculation provides six apron spots for a unit with an 8 PAA and two hangars (8 - 2 = 6), a transient spot (e.g., for a C-17) may be authorized by A4F on a case-by-case basis. If the transient spot is approved, the total available apron spots becomes seven. Adjust to actual PAA and covered spaces.

2.5.3.3 Backup Aircraft Inventory (BAI): Construction of new apron or upgrade of existing apron in support of backup aircraft inventory is not authorized unless approved by NGB/A4.

2.5.4 Design Considerations. Refer to UFC 3-260-01 for siting and planning considerations.

2.5.5 Taxi Lanes and Hangar Access: Refer to UFC 3-260-01 for taxiway / taxi lane definitions and design considerations.

Table 2-6: CATCODE 113-321, Apron Taxi Lanes

Min. Wingtip Clearance for Taxing	Wingspan Less Than 110 ft. (ft.)	Wingspan 110 ft. or More (ft.)
through or primary peripheral taxilane	30	50
interior taxilane	20	30

2.5.6 Alert Pad: Often referred to as an ‘alert apron’, the alert pad is an exclusive paved area where armed aircraft can park with immediate, unimpeded access to a runway. Once an alert has been declared, these aircraft must be on the runway and airborne on short notice; locating the alert pad adjacent to a runway end will allow the alert aircraft to proceed directly from the apron to the runway threshold without interruption from other traffic. Alert pads must not be located within the runway clear zone. Alert pads are authorized in conjunction with alert shelters, where operationally justified. Air Sovereignty Alert has been operationally renamed by AFNORTH as Aerospace Control Alert (ACA) and may be addressed by either term throughout this handbook. See *1st Air Force ACA Site Guide* for the requirement for fighter alert locations. Refer to UFC 3-260-01 for design criteria. If the ANG ACA tasking is less than the typical ACC ACA tasking, fewer alert pads may be required. Final decision on ANG requirements for this mission will be determined by NGB/A4F.

2.6 CATCODE 116-116, Short Field Take-off and Landing Zone

Description: A special paved / unpaved strip, also known as (aka) assault field, provided to train cargo aircraft crews in airlifting operations within a limited space as seen in Table 2-7.

Table 2-7: CATCODE 116-116, Short Field Take-off and Landing Zone

Aircraft Type	Minimum Runway Length (ft.)	Runway Width (ft.)
C-17	3,500 (See Note 1)	90
C-130	3,000	60

NOTE:

1. Add 300 ft. overruns at each end of the land zone.

2.7 CATCODE 116-642, Paved Shoulders

2.7.1 Description: The shoulders of runways, taxiways, aprons, and various airfield pads are paved to protect the shoulder areas against jet blast, reduce maintenance of the unpaved shoulder area, support aircraft outrigger gear, or accommodate snow removal equipment, aircraft service vehicles, and emergency vehicles.

2.7.2 At minimum, pave shoulders to extend at least 0.6 m (2 ft) beyond the edge lights. For apron edges where fire hydrants must be installed, widen the paved shoulder to within 4.6 m (15 ft) of the hydrant to allow paved access for firefighting vehicles. Consult UFC 3-260-01 and ETL 07-3 for further guidance. Below image is from UFC 3-260-01 page 56.

Table 2-8: CATCODE 116-642, Refuelers, C-130s, C-17 Shoulders on each side

Function	Total Shoulder Width (ft.)	Paved Shoulder Width (ft.)
Runway	150	25
Taxiways	50	25
Apron	50	25

Table 2-9: CATCODE 116-642, Exclusive Fighters, Trainers Shoulders on each side

Function	Total Shoulder Width (ft.)	Paved Shoulder Width (ft.)
Runway	150	25
Taxiways	50	10
Apron	50	10

Figure 2-1: CATCODE 116-642, Class B Runway & Taxiway Shoulder Example

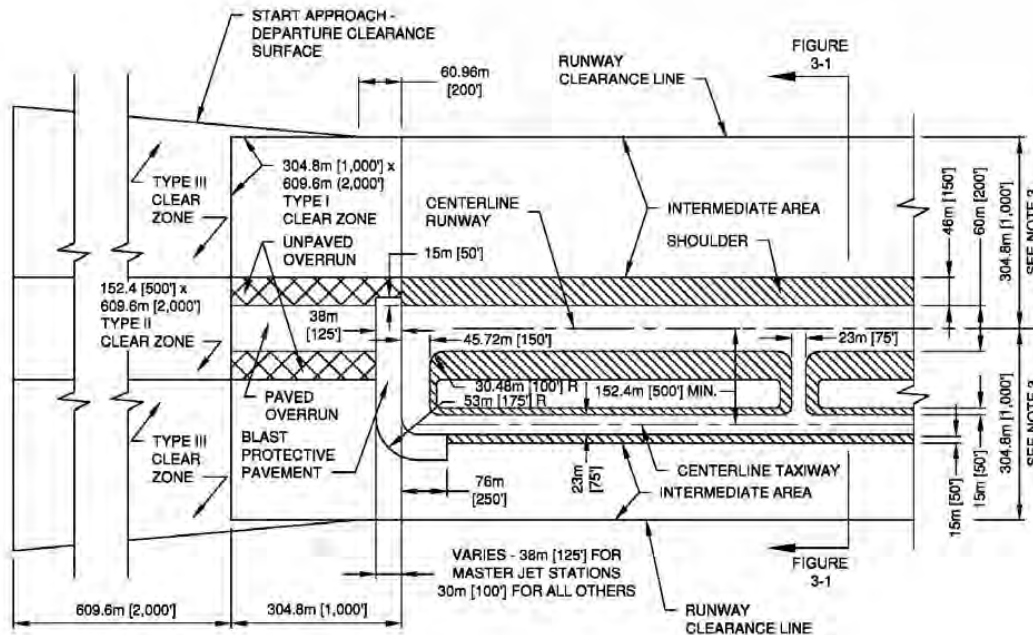

2.7.3 Apron Shoulders: Paved shoulders are provided around the perimeter of an apron to protect against jet blast and foreign object damage (FOD), support blast deflectors, and provide space to store support equipment.

2.8 CATCODE 116-661, Arm / Disarm Pad

- 2.8.1 Description: Used for both the arming of aircraft immediately before takeoff and the disarming (also known as safing) of any weapons retained or not expended upon the aircraft's return. Arm / disarm aprons should be located adjacent to runway thresholds and sited such that armed aircraft are oriented towards the least populated areas or towards revetments.
- 2.8.2 Apron Size: Each arm / disarm pad should be capable of servicing four (4) aircraft at the same time, except for the RPA arm / disarm apron which must be capable of servicing two (2) aircraft at the same time. Arm / disarm aprons to handle more than four (4) aircraft simultaneously must be operationally justified. Apron dimensions may vary with the length and wingspan of the aircraft to be served. The parking locations should have taxi-in / taxi-out capabilities to allow aircraft to taxi to and from their arm / disarm location under their own power. The parking angle is dependent on the type of aircraft, type of weapons, and the associated "uninhabited clear zone" location. The turning radius for taxi lanes on arm / disarm aprons should be designed to provide the minimum allowable turn under power of the largest aircraft which will use the arm / disarm apron. Typical layouts of arm / disarm pads are shown in UFC 3-260-01.
- 2.8.3 Access Road: An all-weather access road should be constructed from the parking apron to the arm / disarm pad apron outside the airfield's taxiway and runway clearance areas.
- 2.8.4 Tie downs and Grounding Points. Tie downs, mooring eyes, or electrical grounding points are not required on arm / disarm pads.
- 2.8.5 See UFC 3-260-01 for general information regarding explosive separation distance, Prohibited Zone, and electromagnetic radiation separation distance requirements. For specific requirements, see DESR 6055.09_AFMAN91-201.

2.9 CATCODE 116-662, Hazardous Cargo Pad

- 2.9.1 Description: These are paved areas for loading and unloading explosives and other potentially dangerous cargo from aircraft. Hazardous cargo pads are required at facilities where the existing aprons cannot be used for the loading and unloading of such items without violating quantity-distance safety criteria. Hazardous cargo pads will be specifically authorized by NGB/A4F. See UFC 3-260-01 for illustrations of various hazardous cargo pads.
- 2.9.2 Siting Criteria: Hazardous cargo pads require explosives site planning, as discussed in UFC 3-260-01.
- 2.9.3 Pad Size: The hazardous cargo pad geometric dimensions as shown in UFC 3-260-01 are minimum requirements. Hazardous cargo pads may be larger than these dimensions if the design aircraft cannot maneuver on the pad. Sources for obtaining information concerning minimum turning radii for various aircraft are presented in Army ETL 1110-3-394, *Aircraft Characteristics for Airfield-Heliport Design and Evaluation*.
- 2.9.4 Access Taxiway: An access taxiway will be provided for access from the primary taxiway to the hazardous cargo pad.
- 2.9.5 Tie downs and Grounding Points. Refer to UFC 3-260-01 for further design considerations.

2.10 CATCODE 116-664, Unsuppressed Power Check Pad

- 2.10.1 Description: A paved area, with an anchor block in the center, used to perform full-power engine diagnostic testing of aircraft engines, either on or off the aircraft. The basic unsuppressed aircraft power check pad is authorized for bases where suppressed pads are not required. This pad may also be used to perform full-power diagnostic testing of engines that are not installed in the aircraft (See [CATCODE 211-193, Test Stand](#)).
- 2.10.2 Location and Siting Considerations: Refer to UFC 3-260-01 for location and siting considerations.
- 2.10.3 Pad Size and Layout: Power check pads may either be rectangular, square, or circular shaped as shown in Table 2-11. See UFC 3-260-01 for illustrations of various unsuppressed power check pad layouts.

Table 2-10: CATCODE 116-664, Unsuppressed Power Check Pad

Geometry Type	Functional Standard (SY)
Rectangular	2,100
Square	2,500
Circular	1,710

- 2.10.4 Access Taxiway: An access taxiway will be provided for access to the power check pad. Since the aircraft may be towed to the power check pad, the access taxiway may be designed for towing the aircraft.
- 2.10.5 Thrust Anchor Block: All unsuppressed power check pads have a thrust anchor block installed in the center of the pad to anchor the engine or the aircraft during engine testing. Thrust anchor blocks are structurally designed for each individual mission aircraft and engine type.
- 2.10.6 Power Check Pad Required Facilities: Paved surface, paved shoulders, thrust anchor block, and blast deflector(s) to protect the surrounding area from jet blast.
- 2.10.7 Power Check Pad Optional Facilities: Optional facilities can be authorized by NGB/A4F depending on the need and justification provided by the unit requesting the optional facilities. These facilities may include: water supply to wash away fuel spills; oil separators, holding tank and containment area for adequate drainage for treatment of fuel wash down before its discharge to a sanitary or storm sewer; communication with both the maintenance control room and the base telephone system, fire hydrants, and a covered facility to perform minor engine adjustments without having to return to the main engine shop if the pad is at a "remote" location (see [CATCODE 211-157, Jet Engine Inspection and Maintenance Shop](#) for additional information and sizing).

1 2.11 **CATCODE 116-665, Power Check Pad (with Noise Suppressor)**

2 2.11.1 Description: The prime facility on which operational checks of jet engines are performed,
3 this type of power check pad usually supports Hush House sound suppressors, which are
4 supplied – with associated devices – as government-furnished equipment (GFE). Optional
5 features listed above (floodlighting, water supply, oil separators, holding tank, treatment of
6 fuel wash down drainage, and communications capability) may also be provided (see HQ
7 *AFLC/DEP Hush House Site Planning Bulletin*).

8 2.11.2 Installations requiring a power check pad with noise suppressor are not authorized an
9 unsuppressed pad. If one already exists, it may be used as a backup or interim facility to the
10 noise-suppressed pad if there is an operational requirement and the noise contour allows it.

11

1 **2.12 CATCODE 116-666, Warm-Up / Holding Pad**

2 2.12.1 Description: Authorized only at commercial airfields and for tankers / airlift aircraft (if
3 required for other aircraft must be approved by NGB/A4F). A paved area adjacent to a
4 taxiway at or near the end of a runway, a warm-up pad (also referred to as a ‘holding apron’)
5 provides a parking location off the taxiway for aircraft that must hold their position during
6 indeterminate delays. This allows other departing or arriving aircraft unencumbered access
7 to the taxiway / runway.

8 2.12.2 The most advantageous position for a warm-up pad is adjacent to the end turnoff taxiway,
9 between the runway and its parallel taxiway. See UFC 3-260-01 for illustrations of various
10 warm-up pad layouts.

11 2.12.3 Pad Size: For pad dimensions and layout see UFC 3-260-01.

12 2.12.4 Tie downs and Grounding Points: Tie downs, mooring points, and grounding points are not
13 required on warm-up / holding pads (see UFC 3-260-01).

14

1 2.14 **CATCODE 116-672, Aircraft Wash Rack**

2 This pad is used for the cleaning of aircraft exterior surfaces. **Covered wash racks is existing**
3 **hangar space.** The unit of measure for the Aircraft Wash Rack is 'EACH'. A corrosion control
4 utility storage building of **100 Gross SF** is authorized to store cleaning supplies and equipment
5 and is listed under [CATCODE 211-161, Corrosion Control Utility Storage](#).

6

2.15 CATCODE 116-922, Aircraft Arresting System (AAS)

- 2.15.1 Description: Aircraft arresting systems consist of engaging devices and energy absorbers. Engaging devices are net barriers, disc supported pendants (hook cables), and cable support systems that allow the pendant to be raised to the battery position or retracted below the runway surface.
- 2.15.2 Energy absorbers can be ship anchor chains, rotary friction brakes, and / or rotary hydraulic systems. The arresting system is government-furnished equipment, as discussed in AFMAN 32-1040, *Civil Engineer Airfield Infrastructure Systems*.
- 2.15.3 Authorized Number: Two aircraft arresting systems are authorized at installations where fighters are assigned and at Combat Readiness Training Centers (CRTCs) (one at each end of the most used runway). If multiple runways are used, the authorization of additional arresting barriers must be approved by NGB/A4F based on operational justification.
- 2.15.4 Procurement: Aircraft arresting systems are centrally procured. The requirements for arresting systems are first submitted by each Major Command (MAJCOM) to Headquarters, Air Force Civil Engineer Support Agency, Civil Engineering Division (HQ AFCEC/CESC) for validation. The arresting systems are then distributed according to the validated requirements; see AFMAN 32-1040 for details.
- 2.15.5 System Siting: Contact the **Air National Guard Engineer Technical Branch, NGB/A4IC**, for aircraft barrier technical support. Criteria for the placement of aircraft arresting systems are shown in Table 2-12.

Table 2-11: CATCODE 116-922, Aircraft Arresting Systems Siting Criteria

Arresting System	Siting Criteria
BAK-9	First 1,000 ft. of runway, or in overrun area (see above)
BAK-12,-13,-14	Ideal (1500 ft. (min) - 1,800 ft.) and 2,200 ft. (max) from threshold

- 2.15.6 Design, Installation, Repair and Runway Pavement: Refer to UFC 3-260-01 for detailed planning guidance and runway pavement assessment information.
- 2.15.7 Joint-Use Airfields: Arresting systems installed on joint-use civil military airfields to support military aircraft are sited in accordance with Federal Aviation Administration (FAA) Advisory Circular (AC) 150/5220-9A, Aircraft Arresting Systems for Joint Civil / Military Airports, which may be obtained from the FAA Advisory Circular database at: https://www.faa.gov/airports/resources/advisory_circulars/index.cfm/go/document.current/documentNumber/150_5220-9 or:

U.S. Department of Transportation
 General Services Section, M-443.2
 Washington DC 20590

1 2.16 **CATCODE 116-945, Jet Blast Deflector**

2 The Jet Blast Deflector is a concave corrugated metal surface, with or without baffles, fastened
3 and braced to a concrete base to withstand the force of the jet blast which is deflected upward and
4 are installed where operationally required. The unit of measure is **linear feet (LF)**. Jet Blast
5 Deflectors are authorized by exception; coordinate with NGB/A4F for approval and siting.

6

Chapter 3: Category Group 12 – Petroleum Dispensing and Operating Facilities

3.1 General Criteria

- 3.1.1 This chapter contains the major criteria and standards for petroleum dispensing and operating facilities at ANG installations nationwide, each of which must receive, store, distribute, and dispense the fuel and lubrication products necessary to achieve its assigned mission.
- 3.1.2 Defense Logistics Agency (DLA) Energy may partially or wholly fund individual Petroleum, Oil, and Lubricants (POL) Sustainment Restoration and Modernization (SRM) projects, but ANG owns, and is responsible for, all POL related programming and real property accountability.

3.2 CATCODE 121-111, Petroleum Operations Building

3.2.1 The petroleum operations building is a centralized facility for the management and control of all base functions related to the handling of petroleum products, including their receipt, storage, and issue. The building also includes a laboratory for conducting prescribed tests to ensure the aircraft fuel products conform to military specifications.

3.2.2 The size of the facility depends on the number of personnel (authorized staffing) assigned to manage fuels as listed in Table 3-1.

Table 3-1: CATCODE 121-111, POL Operations Building, 7 / 16 / 29 Personnel

Major Functions & Breakouts	JCA, RPA		Fighters, Airlift, Tankers		KC-46		Remarks
	Authorized Staffing	Target Area (SF)	Authorized Staffing	Target Area (SF)	Authorized Staffing	Target Area (SF)	
Fuels Chief – Non-Commissioned Officer In Charge (NCOIC)	1		1		1		
Training & Testing							See Chapter 1
Conference & Meeting							See Chapter 1
Administration	1		1		7		
Fuels Dispatcher	1		1		2		
Break Area							Operations / Maint
Operator Maintenance Room	1		9		12		See Note 3
Laboratory	2		3		4		One lab per installation
Accounting	1		1		3		See Note 6
PPE Training Bag Storage							
Subtotal		1,177		1,185		2,246	Net SF
25% Overhead		294		296		561	See Note 4
Subtotal		1,471		1,481		2,807	
Functional Standard		1,500		1,500		2,800	Gross SF

NOTES:

- The Operator Maintenance Room provides space for the storage of coalesce / filter elements; hoses and fittings; meter proving equipment; spare parts such as gages, valves, valve repair kits, etc.; non-sparking and intrinsically safe tools and equipment, etc. associated with the maintenance and repair of the real property installed POL complex equipment.
- Deduct laboratory 300 Gross SF at locations where the host has POL storage.
- The Operator Maintenance room can be combined with the Vehicle Checkpoint room (combined for a total of 300 Gross SF) at those locations where the POL Operations Facility is remote from the load / unload area (see [CATCODE 852-263, Vehicle Parking \(Unsurfaced\)](#)).
- The POL OPS facility should normally be a stand-alone facility due to the fuel vapor clearances required for the other POL facilities.
- If consolidated with another facility reduce overhead to 10% and recalculate the functional standard.
- Accounting position is an additional duty however, due to its sensitive nature; a stand-alone space is required to protect the integrity of the process.

3.3 CATCODE 121-122, Hydrant Fueling System

3.3.1 A hydrant fueling system provides facilities and infrastructure to deliver aviation fuel to fueling points in the aircraft parking apron. Subject to the authorization below, fueling positions, or pits, are not to exceed the Program Authorized Aircraft (PAA) parking positions, minus covered spaces.

3.3.2 A hydrant fueling system is required for the following aircraft:

3.3.2.1 Aircraft with a total tank capacity exceeding 76,000 liters (20,000 gallons)

3.3.2.2 Aircraft, regardless of tank capacity, if a complete economic analysis shows that the annual cost of owning and operating a hydrant fueling system is less expensive than a truck fueling operation

3.3.2.3 Tactical aircraft, regardless of tank capacity, in support of combat turnaround requirements

3.3.2.4 Tactical aircraft in hardened shelters, docks, or specially designed hangars; that is, fuel loop system to aircraft shelter

3.3.3 Hydrant Fueling System Capacity: Hydrant fueling systems are measured in gallons per minute (GPM) and programmed in GPM. The NGB/A4IC (Fuels Engineer) and NGB/A4RMF (Fuels Management Branch) will determine the hydrant system size based on base specific mission requirements and airframe specific upload rates, usually increments of 600 GPM. The pits are accounted for on Real Property Records as outlets (OL).

1 3.4 **CATCODE 121-124, Hydrant Fueling Building**

2 The space houses all the pumps, filter separators, valves, piping, and controls required for
3 operation of the hydrant fueling system. For a Type III hydrant fueling system see DoD Standard
4 Design AW 78-24-28.

5

1 **3.5 CATCODE 123-335, Vehicle Fueling Station (Base Service Station)**

2 3.5.1 Serves government-owned or leased vehicles: Facilities are similar to commercial service
3 stations, with separate storage and dispensing capability for each type of fuel issued.

4 3.5.2 One fueling station shall be provided at each ANG installation not collocated on another
5 DoD installation. Authorization of fueling stations at GSUs will be based upon an analysis
6 that considers the availability and accessibility of fuel from local retail vendors, size and
7 make up of assigned vehicle fleet, fueling by contract supplier, fueling by C-300 / 301
8 mobile refueling vehicles and other alternatives to providing fixed real property assets.
9 When authorized, two canopied dispensing outlets (OL) for ground fuels will be provided
10 for each increment of 150 authorized military / GSA vehicles. Generally, there will be one
11 outlet for motor gas and one outlet for diesel. The need for both grades of fuel must be
12 carefully analyzed and supported before authorization will be provided.

13 3.5.3 Authorization for dispensing and storage of alternate fuels funded by DLA Energy will be
14 determined by completion of a Capitalized Alternative (ALT) Fuels Infrastructure Decision
15 Support Checklist routed through NGB/A4IC, the Air Force Petroleum Agency, to DLA
16 Energy.

1 3.6 **CATCODE 124-134, Operating Storage, Diesel**

2 This tank stores diesel fuel prior to dispensing into vehicles or equipment. Generally, a minimum
3 storage capacity of **5,000 GL** (Flying Unit) and **1,000 GL** (GSU) are authorized unless a greater
4 capacity is needed to meet economic delivery quantities or mission requirements. Requests for all
5 tank sizing shall be routed through NGB/A4F, NGB/A4, the Air Force Petroleum Agency (AFPA)
6 and the DLA Energy Post, Camp and Stations Office.

7

3.7 CATCODE 124-135, Operating Storage, Jet Fuel

- 3.7.1 These tanks (minimum of two (2)) are provided to store jet fuel immediately before it is dispensed into aircraft or refueling service vehicles. Aboveground tanks – which shall conform to all federal, state, and local environmental regulations – are preferred, with their size based on mission support requirements.
- 3.7.2 Minimum mission-based total storage requirements are determined by DLA Energy. Table 3-3 is provided for reference only.

Table 3-2: CATCODE 124-135, Jet Fuel Storage Capacity (planning only)

Aircraft	Storage Quantity (GL)
RPA (MQ-9) – up to 4 PAA	3,000
RPA (MQ-9) – 5 PAA to 18 PAA	4,500
All fighters & HC-130	210,000
C-130	105,000
KC-135	420,000
KC-46	420,000
C-17	315,000

1 3.8 **CATCODE 124-137, Operating Storage, Motor Gas**

- 2 3.8.1 This tank stores motor gas fuel prior to dispensing into vehicles or equipment. Generally, a
3 minimum storage capacity of **5,000 GL** (Flying Unit) and **1,000 GL** (GSU) are authorized
4 unless a greater capacity is needed to meet economic delivery quantities or mission
5 requirements. Requests for all tank sizing shall be routed through NGB/A4F, NGB/A4, the
6 Air Force Petroleum Agency (AFPA) and the DLA Energy Post, Camp and Stations Office.
- 7 3.8.2 GSUs with assigned vehicle fuel pods will not have tank storage but will use the Refined
8 Fuel Distribution system.

9

1 3.9 **CATCODE 125-977, Pump Station, Liquid Fuel**

2 3.9.1 Installations without a hydrant fueling system are authorized this facility – located within
3 the Jet Fuel Storage Complex – to house all pumps, filter separators, valves, piping, and
4 controls required to receive, issue and transfer fuel into and out of the operating storage
5 tanks. Facility will be enclosed and minimally heated where required. This facility includes
6 space for the electrical switching equipment (electrical disconnects), motor control center,
7 pump control panel, fire alarm control panel, automatic tank gauging (ATG) panel,
8 telephone / communications backboard, leak detection equipment, and domestic water
9 heating equipment; space for storage of tools, equipment, parts specific to the maintenance
10 of the fuels complex

11 3.9.2 Functional standard is **1,500 Gross SF**.

12

1
2
3
4
5

3.11 CATCODE 126-926, Liquid Fuel Truck Unloading Stand

3.11.1 Truck unloading stands are provided where jet fuel products are dispensed as a means of unloading from commercial tankers or servicing vehicles.

3.11.2 Criteria: See UFC 3-460-01 for general and design criteria associated with this facility.

Chapter 4: Category Group 13 – Communications, NavAids, Air Traffic Control, & Airfield Lighting

4.1 General Criteria

- 4.1.1 This Category Group is composed of airfield support related CATCODEs. The three main sub-groups are aircraft rescue firefighting station, communications and airfield pavement lighting. Aircraft rescue firefighting activities are related to the airfield and support the ANG aircraft mission.
- 4.1.2 ANG flying missions located at commercial or civil airports are normally under the jurisdiction of the Federal Aviation Administration (FAA) and local airport authority. The FAA is responsible for ground-based aids to air traffic control, air navigation facilities, and airfield lighting programs and operations. In instances where a commercial airport encounters little or no commercial or civil air traffic, and no additional traffic is generated by other DoD and Department of Homeland Security (DHS) activities, the ANG may consider installation of terminal navigational aids such as Instrument Landing Systems and/or tactical air navigation (TACAN) systems. The requirement for terminal navigational aids should be fully documented and submitted to NGB/A3/10 for review and disposition, in coordination with NGB/A4F. NGB/A3/10 has oversight authority for ATCALs/ATC/NAVAIDS in the ANG.
- 4.1.3 Navigation, communication, or meteorological equipment in these facilities are generally Equipment Authorization Inventory Data (EAID) and the responsibility of the Base Air Traffic Control and Landing Systems (ATCALs) Maintenance Shop and maintained accordingly. Ancillary support equipment (e.g. Auxiliary Power Generators and HVAC) for fixed ATCALs items is generally Real Property Installed Equipment (RPIE); the responsibility of the BCE and accordingly maintained.

4.2 CATCODE 130-142, Fire Crash/Rescue Station

- 4.2.1 The ANG Aircraft Rescue Fire Fighting (ARFF) mission is to provide aircraft fire / crash rescue related to the airfield and installation aircraft, and conduct contingency firefighting training. The function must comply with response time standards provided in UFC 4-730-10, *Fire Stations*, and the *USAF Emergency Services Vehicle Validation and Realignment Plan*.
- 4.2.2 The Fire Crash/Rescue Station provides space for apparatus equipment, dispatch/alarm, sleeping quarters (except training stations), recreation / dining, administration, personnel lockers, equipment maintenance, storage, and physical conditioning where applicable.
- 4.2.3 The CATCODE incorporates UFC 4-730-10, *Fire Stations*, and *USAF Emergency Services Vehicle Validation and Realignment Plan* for operational, apparatus, living, maintenance, and equipment criteria, combined with ANG Administrative Area space standards.
- 4.2.4 The total Fire Crash/Rescue Station Functional Standard for a specific installation combines the assigned Vehicle Set Gross SF from Table 4-1 with the Operational and Training Space Summary Gross SF in Table 4-2.
- 4.2.5 The ANG utilizes three types of apparatus bays, defined in UFC 4-730-10: medium, large, and small.
 - 4.2.5.1 Apparatus bay sizes are determined by the specific USAF Vehicle Apparatus Set they house (as detailed in Table 4-1). These Vehicle Sets, linked to ANG weapons systems/airframes, define the total gross square footage (SF) required for the Apparatus Bay.
 - 4.2.5.2 In addition to the truck footprint, the Apparatus Bay area includes clearance space around the parked truck, defined in UFC 4-730-10.
- 4.2.6 Variations to the Functional Standard resulting from additional or reduced requirements of equipment, personnel or other assets will be evaluated through the Functional Standards & CATCODE Adjustments Process as detailed in Chapter 1 and Appendix B of this Handbook.

Table 4-1: CATCODE 130-142, Fire Crash / Rescue Station Vehicle Apparatus Sets

Vehicle Apparatus Set	Primary Airframe / Mission	Bay Size	Functional Standard (GSF) / Target Area (Net SF)
Vehicle Set 1	RPA / C-38 / MC-12 / A-10 / F-15 / F-16 / F-22 / F-35 / HH-60 / Training		10,200 Gross SF
P-22 / 24 Structural Pumper		Medium	936 Net SF
P-22 / 24 Structural Pumper		Medium	936 Net SF
P-30 Rescue Vehicle		Medium	936 Net SF
P-18 / 26 Water Tanker		Medium	936 Net SF
P-19 Crash Truck		Large	1,320 Net SF
P-34 Rapid Intervention Vehicle		Medium	936 Net SF
P-34 Rapid Intervention Vehicle		Medium	936 Net SF
P-31 Hazmat Vehicle		Medium	936 Net SF

Vehicle Apparatus Set	Primary Airframe / Mission	Bay Size	Functional Standard (GSF) / Target Area (Net SF)
Fire Chief Command Vehicle		Small	500 Net SF
Assistant Chief Support Vehicle		Small	500 Net SF
Vehicle Set 3	C-40 / C-130 / HC-130		10,600 Gross SF
P-22 / 24 Structural Pumper		Medium	936 Net SF
P-22 / 24 Structural Pumper		Medium	936 Net SF
P-23 Crash Truck		Large	1,320 Net SF
P-19 Crash Truck		Large	1,320 Net SF
P-30 Rescue Vehicle		Medium	936 Net SF
P-18 / 26 Water Tanker		Medium	936 Net SF
P-34 Rapid Intervention Vehicle		Medium	936 Net SF
P-31 Hazmat Vehicle		Medium	936 Net SF
Fire Chief Command Vehicle		Small	500 Net SF
Assistant Chief Support Vehicle		Small	500 Net SF
Vehicle Set 4	C-17 / KC-135 / KC-46A / CRTC		12,200 Gross SF
P-22 / 24 Structural Pumper		Medium	936 Net SF
P-22 / 24 Structural Pumper		Medium	936 Net SF
P-23 Crash Truck		Large	1,320 Net SF
P-23 Crash Truck		Large	1,320 Net SF
P-19 Crash Truck		Large	1,320 Net SF
P-30 Rescue Vehicle		Medium	936 Net SF
P-18 / 26 Water Tanker		Medium	936 Net SF
P-34 Rapid Intervention Vehicle		Medium	936 Net SF
P-31 Hazmat Vehicle		Medium	936 Net SF
Fire Chief Command Vehicle		Small	500 Net SF
Assistant Chief Support Vehicle		Small	500 Net SF

1
2
3
4
5
6
7
8

NOTES:

1. Fire Chief and Assistant Chief Support Vehicle bays are in addition to UFC requirements.
2. USAF Vehicle Sets 2 and 5 are not used in this table.
3. Functional standard includes 15% overhead.
4. Combine the functional standard for the correct Category Fire Crash/Rescue Station with the correct mission set from Table 4-1 for the total functional standard for the CATCODE.

4.2.7 Fire Station requirements and response time must be validated with the base fire chief in coordination with the Base Civil Engineer, NGB/A4F and NGB/A4OE.

4.2.7.1 The administrative, living, training and equipment / maintenance portion of the Fire Crash/Rescue Station is determined by number of people assigned per shift. Manned stations have a response requirement. Training stations have a training capability but no response requirement.

Table 4-2: CATCODE 130-142, Aircraft Rescue Fire Fighting Stations Categories

Major Functions & Breakouts	Authorized Staffing		Target Area (SF)		Remarks
	Manned	Training	Manned	Training	
Residential & Living	12	0	2,065	100	Net SF – See Note 1
Dorm Rooms	12				
Day Room					
Laundry Room					
Fitness Room					See Note 2
Kitchen / Break Area					
Kitchen Storage					
Dining Area					
Equipment & Maintenance	0	0	1,482	1,296	Net SF
PPE Gear Storage					
Hose Storage					
SBCA Maintenance & Repair					
SBCA Compressor					
Protective Clothing Lockers					
Equipment Wash / Disinfect					
Protective Clothing Laundry & Disinfecting Area					
HAZMAT Equip. Storage					
EMT Storage					
Spare Protective Clothing Storage					
Fire Extinguisher Inspection and Maintenance					See Note 3
Flight line Fire Extinguisher Maintenance.					
Spare Flight line Extinguisher Tank Exterior Covered Storage					100 SF counted as half scope
Training & Administrative	4	4	1,188	1,094	Net SF - See Note 4
Fire Chief	1	1			
Training & Testing / Conference & Meeting Space					See Chapter 1 (combined space based on up to 40 personnel)

Major Functions & Breakouts	Authorized Staffing		Target Area (SF)		Remarks
	Manned	Training	Manned	Training	
Assistant Chief / Shift Supervisor	1	1			Includes fold-up bed space except for Training Station
Assistant Chief, Technical Services	1	1			
Chief of Training	1	1			
HAZMAT / Safety function					
Support	5	2	1,060	400	Net SF
Dispatch / Alarm Room / ECC	5	2			See Note 6
ARFF Agent Storage					75 SF per ARFF Vehicle
Subtotal			5,765	2,890	Net SF
25% Overhead			1,441	723	
Subtotal			7,206	3,613	
Functional Standard			7,200	3,600	Gross SF

NOTES:

1. Training Station is only authorized 100 Net SF for Kitchen / Break Area.
2. [CATCODE 740-674, Physical Fitness](#), establishes the functional standard for the entire installation. Inclusion of physical fitness space in the Fire Crash/Rescue Station will count against this CATCODE unless the following condition applies: Fire fighters will use the base physical fitness area unless prohibited from meeting their established response time standards. In this case, 250 Gross SF for physical fitness may be added to the Fire Crash/Rescue Station and will not count against the installation physical fitness functional standard.
3. The target area for Equipment and Maintenance is based on UFC 4-730-10.
4. The target area for Training and Administrative is based on ANGH 32-1084 [Chapter 1](#).
5. Authorize 150 Gross SF, uncovered patio at no scope; if it is covered it will be half scope.
6. Emergency Communications Center (ECC) standard is 380 Net SF for both fire and security forces functions. If the ECC is relocated to another building; that new space will carry CATCODE 130-142, Fire Crash/Rescue Station. Training Station standard does not include space for ECC.
7. To determine the Total Functional Standard for this CATCODE, combine the Functional Standard for the assigned Vehicle Set Gross SF from Table 4-1 with the respective Fire Crash/Rescue Station Category, Table 4-2, results are summarized in Table 4-3.

Table 4-3: CATCODE 130-142, Aircraft Rescue Fire Fighting Stations Summary

Primary Airframe / Mission	Manned Response Station Functional Standard (Gross SF)	Training Station Functional Standard (Gross SF)
RPA / C-38 / MC-12 / A-10 / F-15 / F-16 / F-22 / F-35 / HH-60	17,400	N/A
C-40 / C-130 / HC-130	17,800	N/A
C-17 / KC-135 / KC-46A	19,400	N/A
Traditional Training Fire Department with no full-time personnel	N/A	13,800

4.3 CATCODE 131-111, Telecommunications

- 4.3.1 Description: The telecommunications function provides a centrally located space for termination of both intra-base and off-base, commercial communications. This space houses the centralized servers, phone switches, equipment maintenance, and administrative areas for the base communications unit.
- 4.3.2 Tenants: If an ANG unit is a tenant on an active-duty installation, the space authorizations are reduced when non-training functions are provided by the host base; if any communications services are contracted out, the space authorizations for those functions are also to be reduced accordingly.
- 4.3.3 NGB/A4F may provide authorization for additional space if a Regional Operations Support Center (ROSC) is located on an installation.
- 4.3.4 Uninterruptible Power Supply (UPS) systems are addressed in AFI 32-1062 and ANG ETL 15-01-05.
- 4.3.5 Some installations may require the addition of an Information Transfer Node (ITN) to meet communications requirements. ITNs shall be designed as large Telecommunications Equipment Spaces. An ITN serves as the collection point for all inter-building fiber within a particular zone of a Base and is directly connected with two distinct routes on the base fiber optic cable backbone. All other facilities in each designated base zone are serviced from the ITN in that zone.
 - 4.3.5.1 ANG Bases normally will have no more than four ITNs. The ITN space must be located within 50 linear feet of the outside plant cable entrance per the National Electric Code but should be as centrally located within the facility as possible. In facilities where ITNs are provided, this space shall also serve as the telecommunications space for that facility.
 - 4.3.5.2 The number and location of base ITNs are determined by the base STEM and documented in the base Communications and Information Systems blueprint.
 - 4.3.5.3 Minimum space requirement for an ITN shall be 110 Net SF.
 - 4.3.5.4 If space is not available in an existing facility, base communications personnel may recommend installation of a self-contained ITN node. This node is an equipment item located on a real property reported equipment pad ([CATCODE 132-133, Equipment Pad](#)).
- 4.3.6 Geographically Separated Units (GSUs) may require a data center and / or communications switch room not to exceed 500 Gross SF collocated with the predominant facility standard. Room size is subject to BCE and Communications Flight validation.

Table 4-4: CATCODE 131-111, Telecommunications Function, 37 Personnel

Major Functions & Breakouts	Authorized Staffing	Target Area (SF)	Remarks
Command & Administrative	2	910	Net SF
Commander	1		
Chief Stan / Eval (QA)	1		
Training & Testing			See Chapter 1
Conference & Meeting			See Chapter 1
Operations	23	920	Net SF
Operations Chief	1		

Infrastructure Shop	6		
Network Operations	5		Workspaces / Equipment
Client Service Center	2		KOM CST Workforce Restructure
Wireless Transmission Shop	4		
Plans & Resources	10	520	Net SF
Plans & Resources Chief	1		
Plans, Programs, Resources & Readiness	3		
Knowledge Operations Management Section	2		KOM CST Workforce Restructure
Base Support (SCXS)	6		
Support / Storage	2	5,829	Net SF
UTC, Preventive Maintenance Inspection, CA / CRL Storage			
Secure Storage Room - Cryptography (Crypto)			Top Secret-certified open storage
Telephone Switch			Climate Controlled
Data Center			Climate Controlled
ITE Staging / Storage			
Records Staging / Storage			Per AFI 33-364
Information Support	1		Storage & Work station
Publishing			
Official Mail Center (OMC)	1		Mail receiving, scanning, sorting, securing & distribution
Media Storage			
Base Computer Classroom			24 work stations
Break Area			
PPE Training Bag Storage			
Subtotal		8,179	Net SF
25% Overhead		2,045	
Subtotal		10,224	
Functional Standard	37	10,200	Gross SF

- NOTE:
1. Deduct 450 Gross SF from the standard for collocated "tenant" units that don't have a telephone switch or if the switch is collocated with the data center.
 2. Add 1,000 Gross SF for G-ASNT Transportable for both collocated or standalone (no further expansion since all current and future needs are accounted for in the 1,000 Gross SF). Entire area is planned to warehouse space standards per paragraph 1.9.5 page 1-12.
 3. Add 4,000 Gross SF if unit is authorized an Eagle Vision UTC 6KVE1.

Figure 4-1: G-ASNT Transportable Layouts collocated or standalone

960 Net SF - Functional Standard 1,000 Gross SF Collocated or Standalone, includes all future needs (no further expansion)

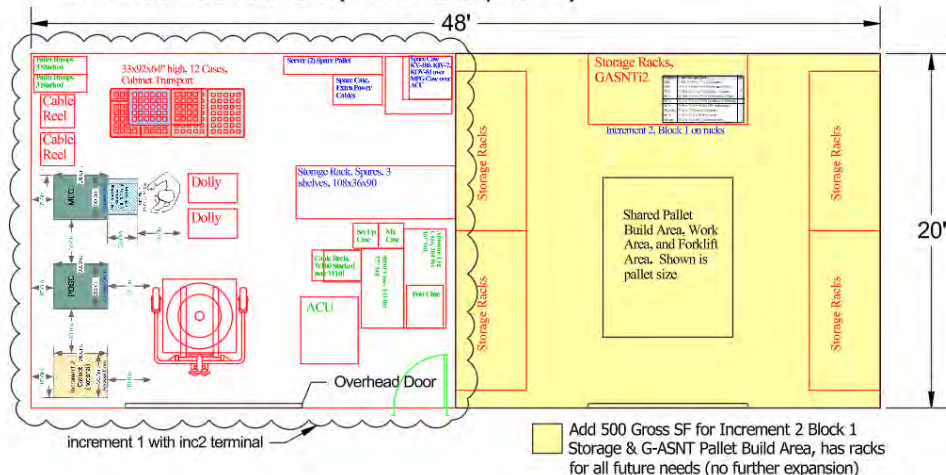

4.3.7 Regional Operations Support Center (ROSC), 10 Personnel

Table 4-5: CATCODE 131-111, Regional Operations Support Center (ROSC), 10 Personnel

Major Functions & Breakouts	Authorized Staffing	Target Area (SF)	Remarks
Commander	1		
Break Area			
ROSC Storage			
Console Area & Crew Positions	9		
Test Lab			
Open ROSC Equipment			
Generator Room			UPS, HVAC, and lighting backup power only
Subtotal		2,970	Net SF
10% Overhead		297	
Subtotal		3,267	
Functional Standard		3,300	Gross SF

NOTE:

- This function is intended to be collocated with another facility. If this is a stand-alone building, increase total overhead to 25% and recalculate the functional standard.

4.3.8 Telecommunications Regional Training Center (RTC)

Table 4-6: CATCODE 131-111, Telecommunications Regional Training Center (RTC)

Major Functions & Breakouts	Authorized Staffing	Target Area (SF)	Remarks
Training Manager	1		
Computer Training Lab			
Server Space			
Subtotal		750	Net SF
10% Overhead		75	
Subtotal		825	
Functional Standard		800	Gross SF

NOTE:

This function is intended to be collocated in the existing Telecommunications Facility.

1 4.4 **CATCODE 131-115, Communications Receiver**

2 4.4.1 Receiver for support of Air Traffic Control (ATC) communications also referenced as 131-
3 115 Ground to Air Radio Receiver Site.

4 4.4.2 ANG flying missions located at commercial or civil airports are normally under jurisdiction
5 of the Federal Aviation Administration (FAA) and local airport authority which are
6 generally responsible for ATC communications. However, in instances where the airport
7 authority does not have this capability, the ANG may provide it.

8 4.4.3 ATC Communications Receiver/ Ground to Air Radio Receiver fixed facilities standard of
9 200 SF unless justified to and approved by NGB/A4F. ATC Communications Receiver/
10 Ground to Air Radio Receiver includes building, antenna foundation, utilities, comm/utility
11 ducts, grounding, lightning protection, ancillary support equipment (if authorized) and access
12 drive. Each facility is generally tailored to its specific mission, incorporating technical,
13 functional, environmental, geographical, and local considerations. Consult the Air Traffic
14 Control Tower and Radar Approach Control Facility Design Guide and AFFSA.

15 4.4.4 The requirement for air traffic control communications should be fully documented and
16 submitted to NGB/A3/10 for review and disposition, in coordination with NGB/A4F.

17
18 4.5 **CATCODE 131-116, Communications Transmitter/Receiver**

19 Collocated transmitter/receiver for support of ATC communications also referenced as 131-116
20 Consolidated Ground to Air Radio Transmitter/Receiver Site. Same requirements as CATCODE
21 131-115.

22
23 4.6 **CATCODE 131-117, Communications Transmitter**

24 Transmitter for support of ATC communications also referenced as 131-117 Ground to Air Radio
25 Transmitter Site. Same requirements as CATCODE 131-115.

26

1 4.7 **CATCODE 132-133, Equipment Pad**

2 4.7.1 General purpose concrete pad used to support equipment, for example RPA Ground Control
3 Station (GCS), RPA Support Operations Center (SOC), RPA Primary Satellite Link (PPSL),
4 Air Control Squadron equipment, equipment training pads, navigational aids, air
5 conditioners, generators, temporary facilities, towers, dishes, etc.

6 4.7.2 Supporting slabs, foundations, grade beams, etc. used to support modular structures,
7 relocatable buildings, or other tent like structures that are not real property.

8 4.7.3 For underground concrete encased ducts used for installation of electrical, telephone cable,
9 fiber optical communications lines, hot water lines, etc. see [CATCODE 890-181, Utility](#)
10 [Line Ducts.](#)

11

12

13

4.8 CATCODE 134-101, Wind Measurement Equipment

- 4.8.1 Fixed Base Automatic Meteorological Station (AN/FMQ-23). Automated airport weather stations are automated sensor suites which are designed to serve aviation and meteorological observing needs for safe and efficient aviation operations, weather forecasting and climatology. Automated airport weather stations have become part of the backbone of weather observing in the United States and Canada and are becoming increasingly more prevalent worldwide due to their efficiency and cost-savings.
- 4.8.2 ANG flying missions located at commercial or civil airports are normally under jurisdiction of the Federal Aviation Administration (FAA) and local airport authority which are generally responsible for meteorological measurements. However, in instances where the airport authority or FAA does not have this capability, the ANG may provide it.
- 4.8.3 Quantitative requirements are locally determined same as 5.17.3
- 4.8.4 The requirement for AN/FMQ-23 should be fully documented and submitted to NGB/A3/10 for review and disposition, in coordination with NGB/A4F.
- 4.8.5 See 5.17 CATCODE 149-621, Wind Measuring Set (AN/FMQ-13) for wind direction and speed for air traffic control operations, weather observations, and forecasting.

4.9 CATCODE 134-102, Automatic Meteorological Station

- 4.9.1 Automatic Meteorological Station (AN/FMQ-19). Consists of a primary suite of weather sensors and processor(s) capable of collecting, measuring, and reporting the following parameters for air traffic control operations: Wind speed and direction, temperature and dew point, visibility, cloud height, present weather, precipitation amount, lightning, and freezing precipitation. For airfields requiring additional weather sensors, one or more additional discontinuity sensor suites may be installed. A discontinuity sensor suite consists of weather sensors and processor(s) capable of collecting, measuring, and reporting the following parameters: Wind speed and direction, visibility, and cloud height.
- 4.9.2 ANG flying missions located at commercial or civil airports are normally under jurisdiction of the Federal Aviation Administration (FAA) and local airport authority which are generally responsible for meteorological measurements. However, in instances where the airport authority or FAA does not have this capability, the ANG may provide it.
- 4.9.3 Quantitative requirements are locally determined same as 5.17.3
- 4.9.4 The requirement for AN/FMQ-19 should be fully documented and submitted to NGB/A3/10 for review and disposition, in coordination with NGB/A4F.

4.10 CATCODE 134-341, Mobile Radar Support

- 4.10.1 The mobile radar sites require a space located adjacent to the mobile Radar Approach Control (RAPCON) vans which will provide support space for the personnel who normally operate and maintain the equipment for up to 24 hours per day. The function includes space for training / study, rest and duty standby, administration, maintenance shop, test equipment storage, latrines, break area, etc. A covered walkway between the mobile units and the support facility may be erected when practicable. If utility connections cannot be made to existing base systems, then a septic tank and underground potable water tank must be installed.
- 4.10.2 All ANG ATC Squadrons are required to have an AN/MPN-14K mobile radar system (UTC 6KBk1).
- 4.10.3 All ANG ATC Squadrons are required 267 SY of [CATCODE 132-133, Equipment Pad](#) for Deployable Instrument Landing System (D-ILS) when assigned and installed. Include with the Pad electrical service and a perimeter grounding ring.

Figure 4-2: D-ILS equipment Pad

267 SY Pad (132-133) for D-ILS

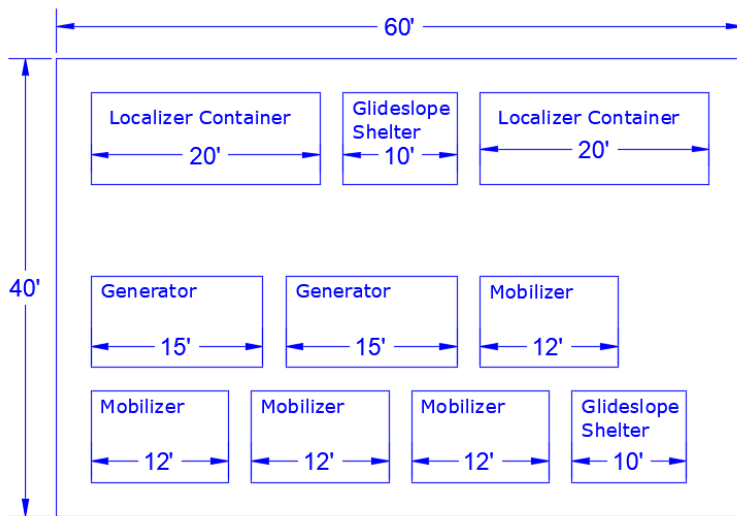

- 4.10.4 Since the facility will be located on the airfield, siting approval must be obtained from the appropriate authority.
- 4.10.5 The requirement for terminal navigational aids should be fully documented and submitted to NGB/A3/10 for review and disposition, in coordination with NGB/A4F.

Table 4-7: CATCODE 134-341, Mobile Radar Support, 37 Personnel

Major Functions & Breakouts	Authorized Staffing	Target Area (SF)	Remarks
Mobile Radar Chief	1		
Conference & Meeting			See Chapter 1
Training & Testing			See Chapter 1
Mobile Radar Controllers	25		10 Hoteling Stations

Radar Maintenance NCOIC	1		
Radar Maintenance Shop	10		
Radar Maintenance Storage			
Radar Simulator			Can be a separate facility
Break Area			
Subtotal		1,980	Net SF
25 % Overhead		495	
Subtotal		2,475	
Functional Standard		2,500	Gross SF

1
 2

1 **4.11 CATCODE 134-351, Instrument Landing System (ILS) Glide Slope**

- 2 4.11.1 The ILS is the standard navigation aid that utilizes fixed radio beams to provide aircraft final
3 approach guidance in instrument conditions.
- 4 4.11.2 ANG flying missions located at commercial or civil airports are normally under jurisdiction
5 of the Federal Aviation Administration (FAA) and local airport authority, which are
6 generally responsible for the ILS. However, in instances where the airport authority does
7 not have this capability, the ANG may provide it.
- 8 4.11.3 The ILS facilities (consisting of Localizer and Glide Slope) includes Equipment Pad (See
9 [CATCODE 132-133, Equipment Pad](#)), antenna foundation, utilities, comm/utility ducts (See
10 [CATCODE 890-181](#)), grounding, lightning protection, ancillary support equipment (if
11 authorized) and access drive. An approach lighting system is required in conjunction with
12 the ILS to ensure a safe transition from the instrument phase to the visual phase (see
13 Approach Lighting, [CATCODE 136-661](#)). For scope and dimensions see UFC 3-260-01 and
14 UFC 3-535-01.
- 15 4.11.4 The requirement for ILS should be fully documented and submitted to NGB/A3/10 for
16 review and disposition, in coordination with NGB/A4F.

17

18 **4.12 CATCODE 134-353, Instrument Landing System (ILS) Localizer**

19 The ILS localizer and glide slope are dependent facilities normally installed in a split site
20 configuration. Same requirements as ILS Glide Slope CATCODE 134-351.

21

22 **4.13 CATCODE 134-375, Radar Approach Control (RAPCON)**

- 23 4.13.1 The RAPCON is an Air Traffic Control (ATC) function using radar and non-radar
24 capabilities to provide approach control services to aircraft arriving, departing, or transiting
25 airspace controlled by the facility. The RAPCON Center provides radar ATC service to one
26 or more civil and / or military airports in a terminal area. Facility may provide services of a
27 ground controlled approach (GCA). RAPCON and GCA services can be provided from
28 fixed, semi-mobile, or mobile facilities.
- 29 4.13.2 Fixed facilities at non-commercial airfields have a functional standard of **6,000 Gross SF**
30 unless justified to and approved by NGB/A4F.
- 31 4.13.3 Mobile facilities are covered under [CATCODE 134-341, Mobile Radar Support](#).
- 32 4.13.4 The requirement for terminal navigational aids should be fully documented and submitted to
33 NGB/A3/10 for review and disposition, in coordination with NGB/A4F.

4.14 CATCODE 134-376, Airport Surveillance Radar (ASR)

- 4.14.1 The ASR is approach control radar used to detect and display an aircraft's position in the terminal area. It provides range and azimuth information.
- 4.14.2 ANG flying missions located at commercial or civil airports are normally under jurisdiction of the Federal Aviation Administration (FAA) and local airport authority which are generally responsible for the ASR. However, in instances where the airport authority does not have this capability, the ANG may provide it.
- 4.14.3 The ASR facility includes Equipment Pad (See [CATCODE 132-133](#)), antenna foundation, utilities, comm/utility ducts (See [CATCODE 890-181](#)), grounding, lightning protection, ancillary support equipment (if authorized) and access drive.
- 4.14.4 The requirement for ASR should be fully documented and submitted to NGB/A3/10 for review and disposition, in coordination with NGB/A4F.

4.15 CATCODE 134-465, Tactical Air Navigation (TACAN)

- 4.15.1 A TACAN is a short range, UHF, line-of-sight air navigation system that provides continuous, accurate slant-range distance and bearing information. TACAN stations may be used as either terminal or enroute aids. When used as a terminal aid, the TACAN should be installed on base adjacent to the runway, as close to the runway centerline as criteria specified in UFC 3-260-01 will permit, see AFMAN 32-1040 for additional guidance. TACAN can be provided from fixed, semi-mobile, or mobile facilities.
- 4.15.2 ANG flying missions located at commercial or civil airports are normally under jurisdiction of the Federal Aviation Administration (FAA) and local airport authority which are generally responsible for the ILS. However, in instances where the airport authority does not have this capability, the ANG may provide it.
- 4.15.3 Typical TACAN Fixed facilities standard is **360 Gross SF** when ANG provided, larger would need justification and coordination. The TACAN Fixed facility includes building, antenna foundation, utilities, comm/utility ducts (See [CATCODE 890-181](#)), grounding, lightning protection, ancillary support equipment (if authorized) and access drive.
- 4.15.4 The requirement for terminal navigational aids should be fully documented and submitted to NGB/A3/10 for review and disposition, in coordination with NGB/A4F.

4.16 CATCODE 134-511, VORTAC, Fixed

- 4.16.1 Same requirements as CATCODE 134-465 TACAN.
- 4.16.2 Navigation aids consisting of collocated TACAN and VOR facilities are known as VORTACs. They provide bearing information on both VHF and UHF bands plus compatible DME. This enables aircraft equipped with either TACAN or VOR/DME to make use of the navigational guidance.
- 4.16.3 Air Force policy requires that TACAN and VOR stations located on the same base and permanently required to support operational missions should be collocated and operated as VORTACs. This enables pairing of facility frequencies according to an established schedule and allows substantial maintenance savings and other ancillary cost savings.
- 4.16.4 VORTAC Fixed facilities will occupy the same TACAN Fixed facilities standard. For scope see UFC 3-260-01.

1 4.17 **CATCODE 136-661, Approach Lighting**

2 4.17.1 Approach lighting is designed to form the sensory coupling between electronic, precision
3 low-approach guidance and the visual reference of runway lighting for the landing of
4 aircraft.

5 4.17.2 Approach lighting at commercial airports is normally provided by the FAA. In cases where
6 Air Force approach lighting criteria exceeds FAA criteria, based on specific and authorized
7 requirements, NGB/A4F may fund the upgrades to achieve the required standards. UFC 3-
8 260-01, *Airfield and Heliport Planning and Design*, and AFMAN 32-1040, *Civil Engineer*
9 *Airfield Infrastructure Systems* criteria will be used at installations where the ANG owns
10 and operates the airfield.

11
12 4.18 **CATCODE 136-664, Runway Lighting**

13 Runway lighting at commercial airports is normally provided by the FAA. In cases where Air
14 Force runway lighting criteria exceeds FAA criteria, based on specific and authorized
15 requirements, NGB/A4F may fund the upgrades to achieve the required standards. Air Force
16 criteria will be used where the ANG owns and operates the airfield. See UFC 3-260-01, *Airfield*
17 *and Heliport Planning and Design*, for details.

18 4.19 **CATCODE 136-667, Taxiway Lighting**

19 4.19.1 Taxiway lighting may be provided for primary taxiways. Reflectors may be installed as an
20 interim measure in place of lighting on the primary taxiway or permanently installed on
21 secondary or seldom-used taxiways.

22 4.19.2 Taxiway lighting at commercial airports is normally provided by the FAA. In cases where
23 Air Force approach lighting criteria exceeds FAA criteria, based on specific and authorized
24 requirements, NGB/A4F may fund the upgrades to achieve the required standards. UFC 3-
25 260-01, *Airfield and Heliport Planning and Design*, and AFMAN 32-1040, *Civil Engineer*
26 *Airfield Infrastructure Systems* criteria will be used at installations where the ANG owns
27 and operates the airfield.

Chapter 5: Category Group 14 – Land Operational Facilities

5.1 General Criteria

- 5.1.1 Land operational facilities include those needed for explosive ordnance disposal (EOD), aerospace Pararescue and recovery functions, audio-visual activities, base operations, crew readiness, squadron operations, deployment processing, air traffic control, meteorological equipment, and range observation, each of which carries its own, unique CATCODE. The requirement for meteorological equipment should be fully documented and submitted to NGB/A3/10 for review and disposition, in coordination with NGB/A4F. NGB/A3/10 has oversight authority for ATCALs/ATC/NAVAIDS in the ANG.
- 5.1.2 Meteorological equipment in these facilities are generally Equipment Authorization Inventory Data (EAID) and the responsibility of the Base Air Traffic Control and Landing Systems (ATCALs) Maintenance Shop and maintained accordingly. Ancillary support equipment for fixed Meteorological equipment (if required) is generally Real Property Installed Equipment (RPIE); the responsibility of the BCE and accordingly maintained.

- 1 5.2 **CATCODE 140-422, Secure Space Mission Planning Cell, Flying Wings**
- 2 5.2.1 This function is intended to be collocated with CATCODE 141-753, Squadron Operations,
- 3 and the authorized Gross SF will be 1,600 SF.
- 4 5.2.2 When assigned and supported, this applies to both Mission Planning Cells for Combat Air
- 5 Forces (CAF) Fighter Squadron Operations Support and Mobility Air Forces (MAF) Flying
- 6 Squadron Operations Support. Applies to RPA by exception.
- 7 5.2.3 Because of the special construction and security measures required, Secure Space area will
- 8 be accounted for separately from all other parts of a facility.
- 9

5.3 CATCODE 141-165, Explosive Ordnance Disposal (EOD) Facility

- 5.3.1 EOD personnel require continuous proficiency training in the application, handling, setup and detonation of specialized explosively driven tools and techniques, bulk explosives, and explosive access charges. They may also be required to train base personnel in explosive ordnance reconnaissance.
- 5.3.2 Installations with EOD flights require administrative working space, a secure training room to accommodate authorized personnel suitable for classes / briefings containing up to (and including) ‘SECRET’ information. A SIPRNET connectivity terminal is required within the secure training room. Collocated storage areas within the same facility for unit and mobility equipment, drive-thru vehicle / trailer / robot storage and maintenance bay with overhead doors, an equipment maintenance workshop, and latrine / shower facilities are also required. Facility must be capable of supporting 24-hour operations for Homeland Defense.
- 5.3.3 Classified information will be stored within the EOD facility. Firearms will be stored in an armory in the EOD facility; and explosive materials will be kept in above-ground magazine storage facilities ([CATCODE 422-258, Above Ground Multi-Cubicle Magazine Storage](#)) or storage igloos ([CATCODE 422-264, Storage Igloo](#)), in accordance with DESR 6055.09_AFMAN 91-201, as well as with all federal, state, and local laws.
- 5.3.4 In addition, EOD must have access – either on base, at a nearby DoD facility or at any other suitable training location – to a demolition range (5 pounds (LB) Net Explosive Weight (NEW) limit). The EOD proficiency training range must meet DESR 6055.09_AFMAN 91-201, *Explosive Safety Standards*.
- 5.3.5 EOD Proficiency Training Range: The facility supports recurrent proficiency training of EOD personnel in order to permit realistic training with live explosives and explosively actuated EOD tools. Provisions are required for exercise of such standard EOD operations as hazard reduction or elimination, emergency destruct techniques with small propellant charges, initiating explosives, and Class 1.1 explosives in quantities appropriate to the training site. New, renovated, or expanded facilities must be sited according to DESR 6055.09_AFMAN 91-201. Locate facilities to comply with explosives safety standards.
- 5.3.6 When possible, the EOD area should be collocated with Base Engineer Maintenance Facility. See [CATCODE 219-944, Base Civil Engineer Maintenance Shop](#) and [CATCODE 610-127, Base Civil Engineer Administration](#).

Table 5-1: CATCODE 141-165, Explosive Ordnance Disposal Facility, 7 / 10 Personnel

Major Functions & Breakouts	Authorized Staffing		Target Area (SF)		Remarks
	7 Pers Team	10 Pers Team	7 Pers Team	10 Pers Team	
Administration	2	3	564	684	Net SF
EOD Engineer		1			
EOD Manager	1	1			
NCOIC	1	1			
Training & Testing					See Chapter 1
Conference & Meeting					See Chapter 1

Major Functions & Breakouts	Authorized Staffing		Target Area (SF)		Remarks
	7 Pers Team	10 Pers Team	7 Pers Team	10 Pers Team	
Operations & Training	5	7	706	838	Net SF
EOD Craftsman	1	1			
EOD Craftsmen	2	4			
EOD Journeymen	1	1			
Admin	1	1			
T.O. / Library (classified)					Secured T.O. & laptops, CBTs
Equipment Room					Two classified safes, chem suits, comm. kits
Laundry					Clean PPE such as EOD-9 bomb suit, body armor, etc.
PPE Training Bag Storage					
Support	0	0	3,200	3,200	Net SF
Equipment Maintenance Room					
Unit/Mobility Equipment Storage					
BSERV / TCV / Robot Maintenance and Storage Bay					
Subtotal			4,470	4,722	Net SF
10% Overhead			447	472	
Subtotal			4,917	5,194	
Functional Standard			4,900	5,200	Gross SF

- 1 NOTE:
- 2 1. If the facility is not collocated, add 100 Net SF for break area, increase the overhead to 25% and recalculate the
- 3 functional standard (Gross SF will be 5,700 SF and 6,000 SF respectively).
- 4

1 5.4 **CATCODE 141-181, Aircraft Shelter**

2 5.4.1 This shelter is for fighter or tactical aircraft with an alert commitment. This function consists
3 of a real property structure to park and protect the aircraft from the elements. Each structure
4 will have drive-thru capability and must meet all airfield clearance criteria. Typically, lesser
5 construction of two walls and no doors. For cold climates; see [Northern Tier Locations](#) and
6 [Weather Extremes](#) in Appendix C. Requires A4F for approval through Advanced Planning
7 to use 141-183 as fully enclosed shelters.

8 5.4.2 The maximum number of fighter and/or tactical aircraft sheltered will be approved by
9 NGB/A4F based on operational requirements, taking into consideration the unit’s PAA less
10 the total number of authorized indoor aircraft parking locations (maintenance hangar, fuel
11 cell, corrosion control, and alert shelters).

12
13 5.5 **CATCODE 141-183, Fighter Aircraft Alert Hangar**

14 5.5.1 This function consists of alert hangars to shelter munitions loaded fighter aircraft on alert
15 status that must respond within prescribed limits.

16 5.5.2 Alert hangars must have fire suppression and be part of an alert complex that has direct
17 runway access and is sited to comply with explosive quantity distance (QD) requirements,
18 airfield restrictive distances and surfaces, and pertinent fire codes. Refer to *Air Combat*
19 *Command (ACC) Air Sovereignty Alert (ASA) Site Guide* or forthcoming guidance from
20 AFNORTH for aircraft shelter planning criteria.

21

5.6 CATCODE 141-185, Guardian Angel

5.6.1 This function consists of command / administrative and support space for a 108-person Operations Group and Rescue Squadron (Guardian Angel). The facility should be located near aircraft parking or alert pad in order to expedite deployment. The unit operates on a continuous peacetime alert status.

5.6.2 All aircraft support elements to include a helicopter hangar are listed under 200-series CATCODES. It is recommended that survival equipment be collocated with this function due to the significant amount of parachute support required.

Table 5-2: CATCODE 141-185, Guardian Angel, 108 Personnel

Major Functions & Breakouts	Authorized Staffing	Target Area (SF)	Remarks
Command & Administrative		1,410	Net SF
Commander			
Training & Testing			See Chapter 1
Conference & Meeting			See Chapter 1
Chief Enlisted Manager			
First Sergeant			
Operations & Training		3,352	Net SF
Director of Operations			
Superintendent			
Administration			
Current OPS			
Plans / Intelligence (Intel)			See Note 1
Director of Standardization and Evaluation (Stan / Eval)			
Stan / Eval NCOIC			
Scheduling			
Director of Logistics			
Readiness NCO			
Medical Director			
Medical Admin			
Flight Chiefs			
Flight Rooms			
Survival, Evasion, Resistance and Escape (SERE)			
PPE Training Bag Storage			
Support		28,395	Net SF
Medical Training Support Equipment			
Independent Duty Medical Technician (IDMT) & Medical Supplies			Includes storage for controlled substances
Laundry Area			See Note 2
Weapons Vault			
Weapons Maintenance			
Drying Room			
Self-Contained Underwater Breathing Apparatus (SCUBA) Equipment Storage / Wash Room			
Parachute Riggers			

Tower (drying / rappelling)			
Parachute Storage			
Supply Administrative / Storage			Based on 10% bench stock overage allowance
Mission Alert Equipment Storage			
Equipment Staging / Mission Buildup			
Individual Equipment Storage			
Guardian Angel Wpn Sys Equipment Storage			See Note 3
Bulk Equipment Storage			
Watercraft Equipment Storage			12 zodiacs inflated stacked two high
Covered storage			See Note 3
Communications			Deployable comm.
Aircrew Flight Equipment			Para-jumper (PJ) personnel only (non-flying)
Fuel Storage			See Note 4
Subtotal		33,157	Net SF
25% Overhead		8,289	
Subtotal		41,446	
Functional Standard		41,400	Gross SF

- 1 NOTES:
- 2 1. Area includes space for secured storage and SIPERNET and provides planning area and computer space for the
- 3 intelligence section.
- 4 2. Includes space for hanging of down clothing and other cold weather gear.
- 5 3. [Northern Tier locations](#) are approved to define the covered storage space as: 14,200 SF covered, enclosed and
- 6 minimally heated storage space. All other locations define space as: 14,200 SF covered shed.
- 7 4. Area provides space for pre-mixed two stroke engine fuel for small boat motors and secondary containment for
- 8 20 gallons (4 each 5 gallon cans).
- 9

5.7 CATCODE 141-383, Audio / Visual

5.7.1 This function provides space a multimedia studio for the production of audio /visual materials. The 3V0xx AFSC have been removed from Comm and moved to a 3N0xx AFSC under Public Affairs (PA) with functional standards assigned under [CATCODE 171-445 Reserve Forces](#) Operational Training. What remains in CATCODE 141-383 is 660SF for the multimedia studio.

Table 5-3: CATCODE 141-383, Audio / Visual

Major Functions & Breakouts	Authorized Staffing	Target Area (SF)	Remarks
Multimedia Studio		600	Includes production, editing, Closed-Circuit Television (CCTV) distribution center
Subtotal		600	Net SF
10% Overhead		60	
Subtotal		660	
Functional Standard		660	Gross SF

NOTES:

1. This function is intended to be collocated with another function and not as a stand-alone facility.

1 **5.8 CATCODE 141-453, Base Operations**

2 5.8.1 This function provides space for numerous functions essential for the daily airfield operation
 3 and should be collocated with the Squadron Operations area. In previous ANGH 32-1084
 4 versions, the space authorization for this function was included under Squadron Operations
 5 ([CATCODE 141-753, Squadron Operations](#) (Sqd Ops)) and was part of the squadron
 6 operations facility.

7 5.8.2 Only one Base Operations is authorized per base that has a flying mission. If an ANG unit
 8 is a tenant on another DoD installation that has a Base Operations, then the ANG unit will
 9 use that Base Operations.

10 **Table 5-4: CATCODE 141-453, Base Operations**

Major Functions & Breakouts	Target Area (SF)	Remarks
Aircrew Briefing		
Airfield Operations		
Flight Planning		
Weather Briefing		
Weather Operations		
Flight Data Management		
Radio Dispatch		
Flight Scheduling		
Subtotal	1,793	Net SF
10% Overhead	179	
Subtotal	1,972	
Functional Standard	2,000	Gross SF

11 **NOTES:**

- 12 1. This function is intended to be collocated with “Squadron Operations” ([CATCODE 141-753, Squadron](#)
 13 [Operations](#) (Sqd Ops))
 14 2. Host provides for Remotely Piloted Aircraft (RPA) Launch and Recovery Element (LRE).
 15

5.9 **CATCODE 141-454, Tactical Operations**

5.9.1 The functions under this CATCODE support operations by non-flying squadrons such as intelligence, range, tactical elements, and support squadrons that have peculiar mission elements or structures required.

5.9.2 Special Tactics Squadron (STS)

5.9.2.1 This function consists of command / administrative and support space for an 127 person Special Tactics Squadron which is comprised of Pararescuemen, Combat Rescue Officers (CRO), Combat Controllers (CCT), Special Tactics Officers (STO), Special Operations Weather Team (SOWT), and specialized support personnel. The function should be located near aircraft parking or alert pad in order to expedite deployment. The unit operates on a continuous peacetime alert status.

5.9.2.2 It is recommended that survival equipment be collocated with this function due to the significant amount of parachute support required.

Table 5-5: CATCODE 141-454, STS, 127 Personnel

Major Functions & Breakouts	Authorized Staffing	Target Area (SF)	Remarks
Command & Administrative	10	1,596	Net SF
Commander	1		
First Sergeant	1		
Conference & Meeting			
Training & Testing			
Combat Control Chief	1		
Pararescue Chief	1		
Personnel	2		
Commanders waiting area			CSS open area
Education and Training	1		
Knowledge Ops Management	1		
Library / Mailroom			
Aviation Resource Manager (ARMS)	1		
Safety Manager	1		
Operations	84	5,698	Net SF
Director of Operations	1		
Assistant Director of Operations	2		
Superintendent of Operations	1		
Current Operations / Training	3		
Plans (FUOPS)	2		
Stan/Eval	3		
Weapons and Tactics	2		SIPR access required
Intelligence	3		
A Troop	16		Pro-rated based on ANG standard
B Troop	16		
C Troop	16		
D Troop	16		
SERE	3		
Training Classroom			
Operations Special Purpose			Redistributed to CUOPS, FUOPS, and Stan/Eval.
Human Performance Program	3		6,000 SF after overhead, have approved layout
Physical Therapist	1		
Performance Coach	1		
Athletic Trainer	1		
Stretching, agility, cardio, weight room			
Rehab area w/equip			

Hydrotherapy Area			
Combat Support	30	22,420	Net SF
Combat Support Officer	1		
Combat Support Superintendent	1		
Medical			
Flight Surgeon	1		
Independent Duty Medical Technician (IDMT)	2		
IDMT Medical Secure Storage			
Medical Logistics	1		
Medical Training Lab			
RF Transmissions	8		
Unit Deployment Manager	1		
CATM Armory to include Vault	2		
Weapons Cleaning/Degreasing			
Logistics Management	2		
Supply Administrative /Storage	2		
Dive Locker Equipment Storage and Maintenance	1		
Aircrew Flight Equipment (AFE) Shop	8		
Parachute packing tables and floor space			
Parachute Storage			
Parachute QA / Staging Area			
Flotation Devices Packing			
Sewing and equipment MX			
O2 Clean room			
NVG storage and testing			
Air Drop Package Build-up			
Drying Tower			
Wash tanks			
Individual Equipment Storage			
Mission Alert Equipment Storage			
Parachute trainer			
Break Area			
Subtotal		29,714	Net SF
25% Overhead		7,429	
STS HPP Gym		6,000	
Subtotal		43,143	
Functional Standard	127	43,100	Gross SF

1
2
3
4
5
6
7
8
9
10
11
12
13
14

NOTES:

1. Restricted access space because of COMSEC materials.
2. Limited access area because of narcotics, secure narcotics storage area, storage area for medical materials/supplies, and wall cabinet with medical sink.
3. This CATCODE requires 640 SY interior / exterior training area (50') for climbing & rappelling tower, helicopter mockup, 40' tall simulated rock wall, simulated urban warfare building face and equipment elevator.
4. The following additional functional standards are also part of the Special Tactics Squadron mission set:
 - [CATCODE 171-212, Simulator Training](#) – IAW Table 6-2 (3,000 Gross SF)
 - [CATCODE 214-425, Vehicle Maintenance Shop](#) – 2,800 Gross SF
 - [CATCODE 442-257, Hazardous Material Storage](#) – 275 Gross SF
 - [CATCODE 442-628, Base Supply & Equip Shed](#) (includes Ops Equip Strg) – IAW Table 9-2 (14,582 GSF)
 - [CATCODE 442-758, Base Supply & Equipment Warehouse](#) – IAW Table 9-3 (8,693 Gross SF)

5.9.3 Cyber Intelligence, Surveillance, Reconnaissance (ISR) Group.

5.9.3.1 A 206-person group responsible for performing digital network intelligence (DNI) analysis of adversary air, space and cyber domains through SIGINT development, post-collection (off-net) analysis of DNI data, and cyber threat discovery activities. The unit also enables collection against key air component priorities/targets in support of computer network exploitation (CNE) efforts. ANG ISR-Cyber units provide Air Force Intelligence, Surveillance and Reconnaissance Agency (AFISRA) with a 24/7 surge digital network intelligence (DNI) capability through federated reach back ops. ISR-Cyber groups provide operational capability and support via one or more operational ISR-cyber squadrons (IS) and an Intelligence Support Squadron (ISS).

Table 5-6: CATCODE 141-454, Cyber ISR Group, 206 Personnel

Major Functions & Breakouts	Authorized Staffing	Target Area (SF)	Remarks
Command & Administration	18	2,816	Net SF
Commander	1		
Vice Commander	1		
Superintendent	1		
Information Management	1		
Education & Training	1		
Resource Advisor	1		
Training & Testing			See Chapter 1
Conference & Meeting			See Chapter 1
Intel Officer	2		
Network Intel Analyst	3		
Crypto Linguist	4		
Cyber Security	3		
Intel Squadron	71	3,256	Net SF
Commander	1		
Operations Officer	1		
Superintendent	1		
Information Management	1		
Personnel Specialist	2		
Education & Training	1		
First Sergeant	1		
Flight A Intel Officer	1		1-1/2 Flights at a time on shift
Flight A Intel Analyst	20		1-1/2 Flights at a time on shift
Flight B Intel Officer	1		1-1/2 Flights at a time on shift
Flight B Intel Analyst	20		1-1/2 Flights at a time on shift
Flight C Intel Officer	1		1-1/2 Flights at a time on shift
Flight C Intel Analyst	20		1-1/2 Flights at a time on shift
Intel Squadron	71	3,256	Net SF
Commander	1		
Operations Officer	1		
Superintendent	1		
Information Management	1		
Personnel Specialist	2		

Education & Training	1		
First Sergeant	1		
Flight B Intel Officer	1		1-1/2 Flights at a time on shift
Flight A Crypto Linguist	20		1-1/2 Flights at a time on shift
Flight B Intel Officer	1		1-1/2 Flights at a time on shift
Flight B Crypto Linguist	20		1-1/2 Flights at a time on shift
Flight C Intel Officer	1		1-1/2 Flights at a time on shift
Flight C Crypto Linguist	20		1-1/2 Flights at a time on shift
Operations Squadron	46	3,448	Net SF
Commander	1		
Operations Officer	1		
Superintendent	1		
Information Management	1		
Personnel Specialist	2		
Education & Training	1		
First Sergeant	1		
Flight A Intel Officer	1		
Flight A Intel Analyst	2		
Flight A Crypto Linguist	3		
Flight B Intel Officer	1		
Flight B Intel Analyst	1		
Flight B Crypto Linguist	2		
Flight C Intel Officer	1		
Flight C Intel Analyst	2		
Flight C Crypto Linguist	2		
Flight D Intel Officer	1		
Flight D Intel Analyst	2		
Flight D Crypto Linguist	2		
Flight E Intel Officer	1		
Flight E Comm Networking	9		
Flight E Comm System Operations	8		
Support	0	1,400	Net SF
Group Server Space			
Break Area			
Subtotal		14,176	Net SF
25% Overhead		3,544	
Subtotal		17,720	
Functional Standard		17,700	Gross SF

1
 2

5.9.4 Cyber Intelligence, Surveillance, Reconnaissance (ISR) Squadron.

5.9.4.1 A 71-person unit responsible for performing digital network intelligence (DNI) analysis of adversary air, space and cyber domains through SIGINT development, post-collection (off-net) analysis of DNI data, and cyber threat discovery activities. The unit also enables collection against key air component priorities/targets in support of computer network exploitation (CNE) efforts. ANG ISR-Cyber units provide AFISRA with a 24/7 surge digital network intelligence (DNI) capability through federated reach back ops.

Table 5-7: CATCODE 141-454, Cyber ISR Sqd, 71 Personnel

Major Functions & Breakouts	Authorized Staffing	Target Area (SF)	Remarks
Command & Administration	10	1,754	Net SF
Commander	1		
Operations Officer	1		
Superintendent	1		
Commander Support Personnel	4		
First Sergeant	1		
Cyber Surety	2		
Conference & Meeting			Chapter 1
Testing & Training			Chapter 1
Intel Operations	61	3,208	
DNI Intelligence Flight			
Intel Officer	1		
Network Intel Analyst	1		
Network Intel Analyst (Shift)	17		Shift Work
DNI Intelligence Flight			
Intel Officer	1		
Network Intel Analyst	2		
Network Intel Analyst (Shift)	17		Shift Work
Current Ops			
Intel Officer, Flight CC	1		
Intel Officer	1		
Network Intel Analyst	4		
Weapons & Tactics Flight			
Intel Officer, Flight CC	1		
Network Intel Analyst	1		
Stan/Eval Flight			
Intel Officer, Flight CC	1		
Network Intel Analyst	2		
Plans Flight			
Intel Officer, Flight CC	1		
Network Intel Analyst	1		
INY Flight			
Intel Officer, Flight CC	1		
COMM Networking	4		
COMM Comp Sys Ops	4		
Support	0	750	Net SF
Squadron Server Space			
Break Area			
Subtotal		5,712	Net SF
25% Overhead		1,428	
Subtotal		7,140	
Functional Standard		7,100	Gross SF

5.9.5 Targeting Intelligence Production Group.

5.9.5.1 A 206-person unit providing surge 24/7 target production and analysis via federated reach back ops to meet OPLAN/COCOM precision targeting requirements levied against air component commanders. Produces electronic target folders & collateral damage estimates and provides bomb damage assessment based on COCOM/JFACC requirements. Target intelligence production and analysis units provide the Air Force Targeting Center (AFTC), aligned under Air Combat Command, with Precision Point Mensuration (PPM) targeting, Collateral Damage Estimate (CDE), Battle Damage Assessment (BDA), Electronic Target Folder (ETF) production, target analysis and imagery intelligence. Targeting intelligence groups provide operational capability and support via one or more operational targeting intelligence squadrons (IS) and an Intelligence Support Squadron (ISS).

Table 5-8: CATCODE 141-454, Targeting Intel Production Group, 206 Personnel

Major Functions & Breakouts	Authorized Staffing	Target Area (SF)	Remarks
Command & Administration	18	2,816	Net SF
Commander	1		
Deputy Commander	1		
Superintendent	1		
Information Management	1		
Education & Training	1		
Resource Advisor	1		
Training & Testing			See Chapter 1
Conference & Meeting			See Chapter 1
Intel Officer	2		
Intel Applications	1		
GeoInt Targeting	3		
Imagery Analyst	3		
Cyber Security	3		
Intel Squadron - Target Production (1)	73	3,965	Net SF
Commander	1		
Operations Officer	1		
Superintendent	1		
First Sergeant	1		
Information Management	1		
Personnel Specialist	1		
Education & Training	1		
DOFA			
Intel Officer	1		
Geospatial Superintendent	1		
Imagery Analyst	12		2 Flights at a time on shift
GeoInt Targeting	8		2 Flights at a time on shift
DOFB			

Intel Officer	1		
Geospatial Superintendent	1		
Imagery Analyst	12		2 Flights at a time on shift
GeoInt Targeting	8		2 Flights at a time on shift
DOFC			
Intel Officer	1		
Geospatial Superintendent	1		
Imagery Analyst	12		2 Flights at a time on shift
GeoInt Targeting	8		2 Flights at a time on shift
Intel Squadron - Target Production (2)	73	3,965	Net SF
Commander	1		
Operations Officer	1		
Superintendent	1		
First Sergeant	1		
Information Management	1		
Personnel Specialist	1		
Education & Training	1		
DOFA			
Intel Officer	1		
Geospatial Superintendent	1		
Imagery Analyst	12		2 Flights at a time on shift
GeoInt Targeting	8		2 Flights at a time on shift
DOFB			
Intel Officer	1		
Geospatial Superintendent	1		
Imagery Analyst	12		2 Flights at a time on shift
GeoInt Targeting	8		2 Flights at a time on shift
DOFC			
Intel Officer	1		
Geospatial Superintendent	1		
Imagery Analyst	12		2 Flights at a time on shift
GeoInt Targeting	8		2 Flights at a time on shift
Intelligence Support Squadron	42	3,024	Net SF
Commander	1		
Operations Officer	1		
Superintendent	1		
Information Management	1		
Personnel Specialist	1		
Education & Training	1		
OSO			
Intel Officer	1		

Imagery Analyst	1		
GeoInt Targeting	1		
OSK			
Intel Officer	1		
Imagery Analyst	2		
GeoInt Targeting	2		
OST			
Intel Officer	1		
Imagery Analyst	4		
GeoInt Targeting	3		
OSX			
Imagery Analyst	2		
GeoInt Targeting	1		
INY			
Comm Comp Sys Ops	9		
Comm Networking	8		
Commander	1		
Support	0	1,400	Net SF
Group Server Space			
Break Area			
Subtotal		15,170	Net SF
25% Overhead		3,792	
Subtotal		18,962	
Functional Standard		19,000	Gross SF

1
 2

5.9.6 Targeting Intelligence Production Squadron.

5.9.6.1 A 107-person unit providing surge 24/7 target production and analysis via federated reach back ops to meet OPLAN/COCOM precision targeting requirements levied against air component commanders. Produces electronic target folders & collateral damage estimates and provides bomb damage assessment based on COCOM/JFACC requirements. Target intelligence production and analysis units provide the Air Force Targeting Center (AFTC), aligned under Air Combat Command, with Precision Point Mensuration (PPM) targeting, Collateral Damage Estimate (CDE), Battle Damage Assessment (BDA), Electronic Target Folder (ETF) production, target analysis and imagery intelligence.

Table 5-9: CATCODE 141-454, Targeting Intel Production Sqd, 107 Personnel

Major Functions & Breakouts	Authorized Staffing	Target Area (SF)	Remarks
Command & Administration	11	2,068	Net SF
Commander	1		
Operations Officer	1		
Superintendent	1		
Commander Support Personnel	3		
First Sergeant	1		
Intel Officer (Cyber Surety)	1		
Cyber Surety	3		
Conference & Meeting			
Testing & Training			
Intel Operations	96	4,904	
Intelligence Flight A			
Intel Officer	1		
Flight Sup	1		
Intel Analyst	3		
Intel Analyst (Shift)	17		Shift Work
Intelligence Flight B			
Intel Officer	1		
Flight Sup	1		
Intel Analyst	3		
Intel Analyst (Shift)	17		Shift Work
Intelligence Flight C			
Intel Officer	1		
Flight Sup	1		
Intel Analyst	3		
Intel Analyst (Shift)	17		Shift Work
Intelligence Support Flight			
Flight CC	1		
Intel Officer	3		
Intel Analysts	13		
Systems Support	13		
Support	0	750	Net SF
Group Server Space			
Break Area			
Subtotal		7,722	Net SF
25% Overhead		1,931	
Subtotal		9,653	
Functional Standard		9,700	Gross SF

5.9.7 Distributed Communications Ground System (DCGS) Group (Large).

5.9.7.1 The Air Force’s globally networked intelligence, surveillance and reconnaissance weapon system to process, exploit and disseminate (PED) the raw data multi-intelligence (INT) sensor feeds from a multitude of collection platforms, including the U-2, RQ-4 Global Hawk, MQ-1 Predator, MQ-9 Reaper, and MC-12 Liberty. The large ANG DCGS Groups are organized, trained, and equipped to PED 1 x high-altitude (U-2, RQ-4), multi-INT 24-hr Combat Air Patrol (CAP), and surge up to 4 x medium-altitude (MQ-1/9, MC-12) CAPs, and provide operational capability and support via one or more operational intelligence squadrons (IS), an Intelligence Support Squadron (ISS), and an Operations Support Squadron (OSS). All are operationally gained by AFISRA. This Group consists of 408 personnel.

Table 5-10: CATCODE 141-454, DCGS Group (Large), 408 Personnel

Major Functions & Breakouts	Authorized Staffing	Target Area (SF)	Remarks
Command & Administration	18	2,880	Net SF
Commander	1		
Vice Commander	1		
Group Superintendent	1		
Group Resource Advisor	1		
Intel Officer	1		
Intel Applications	1		
Imagery Analyst	1		
Special Signals	1		
Sigint Analyst	1		
Elint	1		
Stan/Eval	2		
QA/Pro Super	1		
Conference & Meeting			See Chapter 1
Training & Testing			See Chapter 1
SSO – Intel Officer	1		
Security Office for Indoctrination			
Security Forces	1		
Information Management	1		
Computer Security	1		
Intel Squadron	260	11,100	Net SF
Commander	1		
Operations Officer	1		
Superintendent	1		
Information Management	1		
Personnel Specialist	2		
Education & Training	1		
First Sergeant	1		
Flights A/B/C/D			
Flight CC	4		
Intel Officers	16		Shift work
Analyst Supervisors	10		
Analysts	222		Shift work
Ops Scheduling Area			
Operations Support Squadron	55	4,128	Net SF
Commander	1		
Operations Officer	1		

CCQ - Superintendent	1		
Information Management	2		
Personnel Specialist	1		
Education & Training	1		
First Sergeant	1		
Mission Operations (OSO)			
Intel Officer	1		
Intel Applications	8		
Analysts	11		
Mission Planning Room			
Weapons and Tactics (OSK)			
Intel Officer	1		
Intel Applications	1		
Analysts	3		
Ops Plans (OSX)			
Intel Officer	1		
Intel Applications	1		
Analysts	5		
Ops Training (OST)			
Section Commander	1		
Intel Applications	3		
Analysts	11		
Ops Training Area (Simulator)			
Intel Support Squadron	75	3,539	Net SF
Commander	1		
Operations Officer	1		
Superintendent	1		
Information Management	2		
Personnel Specialist	1		
Education & Training	1		
First Sergeant	1		
Maintenance Support (INU)			
Comm Net, Crypto Super	1		
Comm Net, Crypto	3		Shift work
Comm Comp Sys Ops	6		Shift work
Maintenance Support (INS)			
Comm Net, Crypto	16		Shift work
Comm Comp Sys Ops	18		Shift work
Maintenance Support (INX)			
Comm Net, Crypto	3		Shift work
Info Management	5		
Comm Comp Sys Ops	2		Shift work
Maintenance Support (INY)			
MX Data	2		
Supply	4		
Comm Network	4		
Plans	3		
MX Workroom/Bench			
Sentinel Mission Equipment Areas		12,840	Net SF
S+W Transit Case Storage			

CETS Transit Case Storage			
High MSN Crew			
Mid Alt Crew			
High Mission Comm Racks			
Med Mission Comm Racks			
UPS			
Support		4,288	
Ops Mission Briefing Room			
Crew Reconstitution Area			
Disintegration Room			
VTC Room (JWICS)			
VTC Room (Collateral)			
Receiving/Storage			
PPE Training Bag Storage			
Hoteling Stations			
Contractor Mission Support	19	704	
10.2 SSLSM Contractor	8		Shift work
CFSR Contractor	4		Shift work
S+W Contractor	2		
Advanced Concepts Contractor	1		
GCP Contractor	4		Shift work
Subtotal		39,479	Net SF
25% Overhead		9,870	
Subtotal		49,349	
Functional Standard		49,300	Gross SF

1
 2

5.9.8 Distributed Communications Ground System (DCGS) Group (Small).

5.9.8.1 The Air Force’s globally networked intelligence, surveillance and reconnaissance weapon system to process, exploit and disseminate (PED) the raw data multi-intelligence (INT) sensor feeds from a multitude of collection platforms, including the U-2, RQ-4 Global Hawk, MQ-1 Predator, MQ-9 Reaper, and MC-12 Liberty. The small ANG DCGS ISR Groups are organized, trained, and equipped to PED up to 4 x medium-altitude (MQ-1/9, MC-12) CAPs, and provide operational capability and support via one or more operational intelligence squadrons (IS), an Intelligence Support Squadron (ISS), and an Operations Support Squadron (OSS). Other stand-alone small ANG DGS groups/squadrons are Classic Associate Units (CAU) to active duty AF DGS Groups. All are operationally gained by AFISRA. This Group consists of 240 personnel.

Table 5-11: CATCODE 141-454, DCGS Group (Small), 240 Personnel

Major Functions & Breakouts	Authorized Staffing	Target Area (SF)	Remarks
Command & Administration	18	2,816	Net SF
Commander	1		
Vice Commander	1		
Ops Officer	1		
Group Superintendent	1		
Group Resource Advisor	1		
Information Manager	2		
Intel Officer	1		
Intel Superintendent	1		
Intel Applications	1		
Imagery Analyst	4		
Sigint Analyst	1		
Security Forces	1		See Chapter 1
Computer Security	1		See Chapter 1
Security Officer	1		
Conference & Meeting			
Testing & Training			
Intel Squadron	120	2,338	Net SF
Commander	1		
Ops Officer	1		
Superintendent	1		
Information Manager	2		
Personnelist	1		
Education and Training 3S2	1		
CCF - First Sergeant	1		
Ops Scheduling Area			
DOFA			
Flight CC	1		
Intel Officers	3		Shift Work
Image Analyst	20		Shift Work
Intel Applications	4		Shift Work
DOFB			
Intel Officers	4		Shift Work
Image Analyst	20		Shift Work
Intel Applications	4		Shift Work
DOFC			
Intel Officers	4		Shift Work
Image Analyst	20		Shift Work

Intel Applications	4		Shift Work
DOFD			
Intel Officers	4		Shift Work
Image Analyst	20		Shift Work
Intel Applications	4		Shift Work
Operations Support Squadron	52	4,840	Net SF
Commander	1		
Ops Officer	1		
Superintendent	1		
Info Management	2		
Personnel	1		
Education and Training	1		
CCF - First Sergeant	1		
Mission Operations (OSO)			
Intel Officer	1		
Intel Applications	8		
Sigint Analyst	12		
Mission Planning Room			
Weapons and Tactics (OSK)			
Intel Officer	1		
Intel Applications	1		
Imagery Analyst	2		
Sigint Analyst	1		
Ops Plans (OSX)			
Intel Applications	1		
Imagery Analyst	2		
Sigint Analyst	3		
Ops Training (OST)			
Intel Officer	1		
Intel Applications	3		
Imagery Analyst	6		
Signals Analyst	2		
Ops Training Area (Simulator)			
Intel Support Squadron	50	3,545	Net SF
Commander	1		
Ops Officer	1		
Superintendent	1		
Information Manager	1		
Personnelist	1		
Education and Training	1		
CCF - First Sergeant	1		
SCQ			
Comm Net, Crypto	6		
Comm Comp Sys Ops	6		
SCX			
Comm Net, Crypto	5		
Comm Comp Sys Ops	5		
SCO			
Comm Net, Crypto	10		
Comm Network	10		
Plans	1		
MX workroom/bench			
Sentinel Mission Equipment Areas		5,630	Net SF

S+W Transit Case Storage			
Mid Alt Crew			
Med Mission Comm Racks			
UPS			
Miscellaneous/Common		2,560	
Ops Mission Briefing Room			
Crew Reconstitution Area			
Disintegration Room			
VTC Room (JWICS)			
VTC Room (Collateral)			
Receiving/Storage			
PPE Training Bag Storage			
Contractor Mission Support	11	448	
10.2 SSLSM Contractor	4		Shift work
CFSR Contractor	2		Shift work
S+W Contractor	2		
ISSO/ISSM	2		
Tybrin	1		Shift work
Subtotal		22,177	Net SF
25% Overhead		5,544	
Subtotal		27,721	
Functional Standard		27,700	Gross SF

1
 2
 3

5.9.9 **Electromagnetic Warfare Squadron (EWS).**

5.9.9.1 A deployable offensive and defensive counterspace unit responsible for operating space control capabilities to rapidly achieve flexible and versatile Space Superiority in support of theater campaigns. The unit participates in the evaluation and operation of counterspace technologies to meet combatant commander requirements. This squadron consists of 88 personnel.

Table 5-12: CATCODE 141-454, Electromag Warfare Squadron, 88 Personnel

Major Functions & Breakouts	Authorized Staffing	Target Area (SF)	Remarks
Command & Administration	7	1,610	Net SF
Commander	1		
First Sergeant	1		
Knowledge Ops & Personnel	4		
Training Manager	1		
Conference & Meeting			See Chapter 1
Training & Testing			See Chapter 1
Operations	56	3,228	
Director of Operations	1		
DOS	4		
DOV	1		
DOT	3		
Classroom			25 persons @ 20 SF/person
Hotel Stations - Operators	8		
Operations Area x 2	40		20 ft x 50 ft open admin area x 2
Maintenance	12	3,756	
LGX	2		
LGRM	2		
Maintenance (Age & RF) and Storage	8		
Security Forces	13	631	
Security Operations	3		
Security Forces	10		Hotel space
SF PPE/Training Bag Storage			
SF Equipment Storage			
ECP and Entrapment Area			
Support		213	Net SF
PPE/Training Bag Storage			
Break Area			
Subtotal		9,438	Net SF
25% Overhead		2,359	
Subtotal		11,797	
Functional Standard		11,800	Gross SF

Note:

The following additional functional standards are also part of the Offensive Counter Space Squadron mission set:

1. CATCODE 442-257, Hazardous Material Storage - 300 Gross SF
2. CATCODE 852-261, Vehicle Parking Ops - 200 SY
3. CATCODE 852-262, Non-Organizational Vehicle Parking - 2,300 SY

1

Table 5-13: CATCODE 141-454, Defensive Space Control Sqd, 88 Personnel

Major Functions & Breakouts	Authorized Staffing	Target Area (SF)	Remarks
Command & Administration	7	1,610	Net SF
Commander	1		
First Sergeant	1		
Knowledge Ops & Personnel	4		
Training Manager	1		
Conference & Meeting			See Chapter 1
Training & Testing			See Chapter 1
Operations	62	4,256	
Director of Operations	1		
Operations Support	3		
Current Operations	1		
Current Operations Support	2		
Cyber Ops	1		
Cyber Ops Support	2		
Security Forces	2		
ECP and Entrapment Area			
Classroom			25 persons @ 20 SF/person
Hotel Stations - Operators			Hoteling for 20 operators
Operations Area x 2	50		two 25 ft x 50 ft open admin areas
Maintenance	19	3,892	
LGX	3		
LGRM	2		
Hotel Stations - Maintenance	6		
Maintenance (Age & RF) and Storage	8		
Support		229	Net SF
PPE/Training Bag Storage			
Break Area			
Subtotal		9,987	Net SF
25% Overhead		2,497	
Subtotal		12,484	
Functional Standard		12,500	Gross SF

2

Note:

3

The following additional functional standards are also part of the Defensive Counter Space Squadron mission set:

4

1. CATCODE 442-257, Hazardous Material Storage - 300 Gross SF

5

2. CATCODE 852-261, Vehicle Parking Ops - 200 SY

6

3. CATCODE 852-262, Non-Organizational Vehicle Parking - 2,300 SY

7

4. CATCODE 132-133, Equipment Pad (for 13 Antennas) - 1,400 SY

8

5.10 CATCODE 141-459, Crew Readiness

5.10.1 Function designed for fighter alert crews and aircraft that directly support air defense and other alert missions in a continuous ready-to-go status. This facility provides space for operations, crew quarters, and recreation.

5.10.2 The fighter aircraft crew readiness facility must be located to comply with explosives safety standards. Refer to *Air Combat Command (ACC) Air Sovereignty Alert (ASA) Site Guide* or forthcoming guidance from AFNORTH for planning and design guidance, below table matches current ACC/ASA guidance.

Table 5-14: CATCODE 141-459, Fighter Alert Crew Readiness

Major Functions & Breakouts	Authorized Staffing	Target Area (SF)	Remarks
Individual Bedroom/Study Area/Restroom	12		150 SF/person (includes study area and restroom)
Maintenance Ready Room			
Pilots Ready Room			
Briefing Room			Includes Break Area
Exercise Room			Includes male/female restrooms
Kitchen			
Food Storage			25 SF/Rotation
Dining Area			10 SF/Person
Vending Area			
Laundry Room			
Personal Lockers (M/F)			5 SF/person x 36 people
Operations Area			
Supervisor of Flying (SOF) Office			
Operations Office			
Maintenance Operations Office			
Mission Planning/Storage			
Subtotal		5,035	Net SF
Overhead Factor (30%)		1511	
Subtotal		6,546	
Functional Standard		6,500	Gross SF

Figure 5-1: Fighter Alert Crew Quarters, ACC/ASA Guide

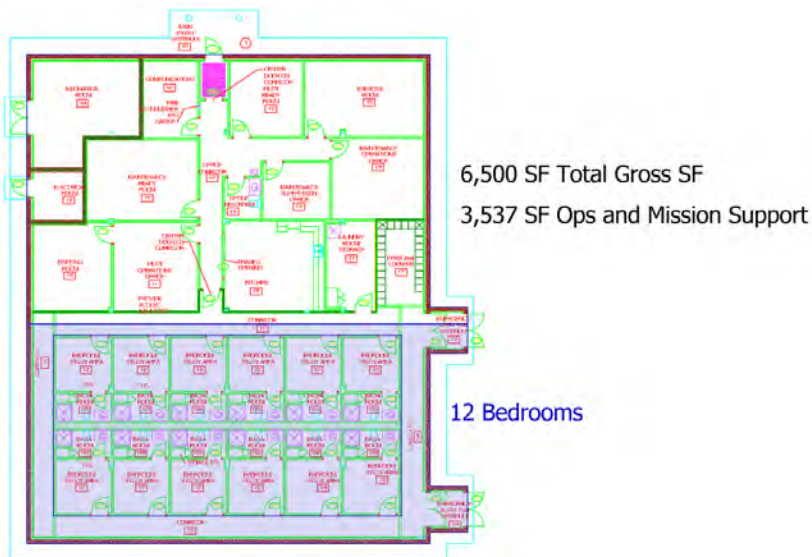

1 5.10.3 Space for tanker alert crew readiness is authorized at installations tasked with an alert
 2 mission – **only units with standing alert will be prioritized for construction**. Table 5-13
 3 provides a Functional Standard for a crew readiness located within the Squadron Operations
 4 Facility.

5 **Table 5-15: CATCODE 141-459, Tanker Alert Crew Readiness, 4/6/8 Personnel**

Major Functions & Breakouts	Target Area (SF) by Category			Remarks
	4	6	8	
Bedrooms				
Bedroom				
Restrooms (unisex w/shower)				unisex w/shower
Ready Room				Includes briefing room and break area
Exercise Room				
Kitchen				
Dining Area				20SF/person
Laundry room				
Personal Lockers (M/F)				
SOF Office				
Operations Office				
Mission Planning/Storage				
Subtotal	2,126	2,761	3,396	Net SF
10% Overhead	212.6	276.1	339.6	
Functional Standard	2,300	3,000	3,700	Gross SF

6 **NOTES:**

- 7 1. This function is intended to be collocated with [CATCODE 141-753, Squadron Operations](#). If separate facility,
 8 then use **2,700 Gross SF for 4 bedrooms, 3,500 Gross SF for 6 bedrooms, or 4,200 Gross SF for 8 bedrooms**.
 9 2. This CATCODE is only authorized for units with a standing alert. Units requesting space under this CATCODE
 10 must submit a request to NGB/A4F for approval.
 11

5.11 CATCODE 141-461, Command Post

5.11.1 The purpose of a command post (CP) is to provide commanders with the capability to receive and disseminate time critical mission-essential information, operational reporting, effectively track and account for wing assets, actions and missions during routine operations, federal and state Defense Support of Civil Authorities (DSCA) emergencies, contingencies, and increased readiness postures. It also provides space for coordinating and orchestrating responses to emergency incidents.

5.11.1.1 The Command Post CATCODE is subdivided into four major elements:

5.11.1.1.1 Command Post Element

5.11.1.1.2 Emergency Operations Center (EOC)

5.11.1.1.3 Commanders Action Team (CAT)

5.11.1.1.4 Installation Command & Control (IC2)

5.11.2 The space authorization for this function was previously included under Squadron Operations ([CATCODE 141-753, Squadron Operations \(Sqd Ops\)](#)) and was a part of the squadron operations functional standard.

5.11.3 Per AFMAN 10-207, Para 2.5.9, commanders will establish and maintain an alternate CP space that supports fixed / deployed operations. The operational capability of the Alternate Command Post (ACP) must mirror the capability of the primary space to support command, control, communications, computers, and intelligence (C4I) requirements. ANG Facility Space Standards do not provide a space dedicated to the ACP. Bases must utilize existing dual purpose spaces for this function.

Table 5-16: CATCODE 141-461, Command Post, 36 Personnel

Major Functions & Breakouts	Authorized Staffing	Target Area (SF)	Remarks
Command Post Element		1,257	Net SF
EA Cell / Console Area	3		
CP Managers / Administrative Section	3		
Training & Conference			See Chapter 1
Frame Room			
Security Checkpoint	1		
Break Area / Kitchenette			
Unisex Restroom			
Storage			
Emergency Operations Center (EOC)	17	762	Net SF – See Note 4
Commanders Action Team (CAT)	10	366	Net SF - See Note 5
Installation Command & Control (IC2)	2	128	Net SF

Subtotal		2,513	Net SF
10% Overhead		251	
Subtotal		2,764	
Functional Standard		2,800	Gross SF

NOTES:

1. This function is intended to be collocated with a larger facility.
2. CRTCs require only one command post for normal operations. Command Post / EOC / CAT and IC2 training spaces are included in [CATCODE 171-445, Reserve Forces Operational Training](#).
3. Refer to AFI 10-207, *Command Posts* for additional information and specific facility requirements and design criteria.
4. Includes space for CBRN cell. The EOC function should be located in a separate facility, but the Installation Commander should consider local constraints to decide the final location of this function.
5. Add 200 SF to this CATCODE 141-461 for G-ASNT when assigned and installed.

1
 2
 3
 4
 5
 6
 7
 8
 9
 10
 11

5.12 CATCODE 141-753, Squadron Operations (Sqd Ops)

5.12.1 Each flying squadron requires a facility or functional area for the training, planning, briefing, administration, and critique of aircrew operations. Space for [CATCODE 141-461, Command Post](#) and [CATCODE 141-453, Base Operations](#) support the Squadron Operations function but are not included in this space standard.

5.12.2 Functional areas include and support weapons and tactics, intelligence, briefing and debriefing, air advisor, flying safety, standardization and evaluation, flight planning, personal protective equipment storage, flight records, flight equipment shop, scheduling, general training, and group or wing operations.

5.12.3 Table 5-18 summarizes the weapons systems authorized a squadron operations facility or functional area. Tables 5-19 to 5-39 detail the functional space for each weapon system.

Table 5-17: CATCODE 141-753, Squadron Operations Summary

Aircraft / Mission	Functional Standard (Gross SF)	Remarks
F-15 / F-16	<u>17,500</u>	See Note 1
F-15EX	<u>17,100</u>	
F-22 / F-35	<u>17,500</u>	
C-130H	<u>19,800</u>	
C-130J	<u>18,400</u>	
C-17	<u>22,600</u>	
C-38 / C-40	<u>10,200</u>	
C-32	<u>6,400</u>	
KC-135	<u>18,200</u>	
KC-135 (Active Association)	<u>20,000</u>	
KC-135 Two Sqdns	<u>23,900</u>	Two Flying Squadrons
KC-46 12PAA (Active Association)	<u>31,000</u>	Crew Ratio Increase
KC-46 12PAA	<u>26,400</u>	
KC-46 8PAA (Active Association)	<u>23,400</u>	
KC-46 8PAA	<u>18,600</u>	
Rescue HC-130 / HH-60	<u>24,800</u>	
RPA	<u>12,300</u>	
CRTC	<u>15,200</u>	7,600 SF for Cadre and 7,600 SF for visiting units in separate facilities
ASOS	<u>15,500</u>	

NOTE:

- Add 200 Gross SF for Reconnaissance (RECCE) / Tactical Air Reconnaissance System (TARS) – may be satisfied by Photo Processing and Interpretation Facility (PIIF).

1 5.12.4 Squadron Operations, A-10 / F-15 / F-16 Fighter, 88 Personnel

2 **Table 5-18: CATCODE 141-753, Sqd Ops, F-15 / F-16 , 88 Personnel**

Major Functions & Breakouts	Authorized Staffing	Target Area (SF)	Remarks
Command & Administration	4	1,558	Net SF
Group Commander	1		
Group Superintendent	1		
Training & Testing			See Chapter 1
Conference & Meeting			See Chapter 1
Orderly Room – Information Management Specialist	1		
Stan / Eval Officer	1		
T.O. Library			
Fighter Squadron	39	1,584	Net SF
Commander	1		
Administration Support – Information Management Specialist	2		
Duty Desk	2		
Director of Operations	1		
Assistant Director of Operations	1		
A, B, C, D Flight Commanders	4		
Pilots	24		7 Hoteling Stations
Flight Safety Officer	1		
Enlisted Support Section	3		
Aircrew Flight Equipment	14	5,843	Net SF - See Note 1
Superintendent	1		
NCOIC/QA Office	3		
T.O. Library/Hotel Stations			
Centralized Aircrew Flight Equipment Shop	3		
Helmet / Oxygen Mask Repair	1		
Aircrew Training Room			
Flotation Room – Life Raft / Life Preserver Maintenance & Storage	1		
Fabrication / Parachute Packing Room	1		
Ejection Seat Survival Kit Packing Area	1		
ACBRN BOI, ACCA, TMDE, AFE Mobility Storage	1		
Laundry / Wash Room			
NVD Maintenance/Inspection/Pre-Flight Room	1		
JHMCS / HMIT Maintenance & Storage Room			
Aircrew Personalized Equipment Storage Lockers	1		10 SF/Person (24"x24" locker with circulation)
Mobility Storage (Tasked UTCs) / PPE			
Operations Support Flight	7	700	Net SF
Commander	1		

Administration Support – Information Management Specialist	1		
Training Officer	1		
Current Operations	1		
Aviation Resources Management (ARMs)	3		
ARMs Storage			
Secure Area / Vault	24	4,067	Net SF
Senior Intelligence Officer	1		
Intelligence Officer	3		
Intelligence NCO	7		
Weapons & Tactics	3		
Mission Planning Space	5		
Brief / Debrief Rooms			6 Each – seating for 8
Classified Main Briefing Room			
PM/PS/APSM	3		
SSR/IAO	2		
Secure Closet			
Communications Support			ACC Standard
Support	0	238	Net SF
Break Area			
PPE Training Bag Storage			
Subtotal		13,990	Net SF
25% Overhead		3,498	
Subtotal		17,488	
Functional Standard		17,500	Gross SF

1
 2
 3
 4
 5
 6
 7
 8
 9
 10
 11
 12

NOTES:

- Units that have the Embedded Combat Weather Team are authorized an additional 950 Gross SF under [CATCODE 171-443, Reserve Forces General Training Support](#) to support this function.
- Add 600 SF for Optimizing the Human Weapon System (OHWS) at Combat Air Forces (CAF) locations only and only when assigned and activated with supporting trainer.
- Flight scheduling, Flight Data Management, Airfield Operations and Weather are located in [CATCODE 141-453, Base Operations](#).
- Part of this standard was originally under CATCODE 218-852, Survival Equipment Shop which has been deleted and merged into the Aircrew Flight Equipment function.

5.12.5 Squadron Operations, F-15EX Fighter, 82 Personnel.

Table 5-19: CATCODE 141-753, Sqd Ops, F-15EX , 82 Personnel

Major Functions & Breakouts	Authorized Staffing	Target Area (SF)	Remarks
Command & Administration	3	1,550	Net SF
Group Commander			
Group Superintendent			
Conference & Meeting			See Chapter 1
Training & Testing			See Chapter 1
Stan/Eval Officer			Lt Col Position
Tech Order Library			
Fighter Squadron	26	1,248	Net SF
Commander			Pilot
Deputy Cmdr of Operations			
Aviation Resource Mngt			Moved to SAPF
Flight Surgeon			
Medical Staff			
Flight instructor			Major position
A, B, C, D Flight Commanders			Lt Col Pilots
Pilots			Moved to SAPF
Pilots			24 x 50% = 9 @ 24 SF/person
Aircrew Flight Equipment	10	5,607	Net SF
Superintendent			
TO Library/Hotel stations			
Centralized Aircrew Flight Equipment Shop			Inclusive of parachute harness, anti-g, and ACBRN inspection/maintenance areas
Helmet/Oxygen Mask Repair Area			
Aircrew Training Room			includes egress and hanging harness
Flotation Room – Life Raft/Preserver Mx & Storage			
Fabrication/Parachute Packing Room			Sized for two tables
Ejection Seat Survival Kit Packing Area			
ACBRN BOI, ACCA, TMDE, AFE Mobility Storage			
Laundry/Wash Room			
NVD Maintenance/Inspection/Pre-flight Room			
JHMCS/HMIT Maintenance & Storage Room			
Aircrew Flight Equipment Storage Lockers			37 @ 10 SF/Person (24"x24" locker with circulation)
Mobility Storage (Tasked UTCs)/PPE			1.5 SF/person
Operations Support Flight	0	0	Moved to SAPF
Fighter Advanced Programs (SAPF)	21	5,078	Net SF
Ops Spt Commander			Moved from Operations Support Flight
Wing CCZ Staff Office			1 private office + 2 cubicles (from Fighter Sq)
Wing CCZ Staff Office			5 non UMD positions
Weapons and tactics			OSS UMD position 1 with 3 pilots
Flight Planning / Post Flight Review Stations			contractors 15 workstations
Flight Briefing / Debriefing Rooms			6 ea rooms @ 192SF - seating for 8 ppl + 100 SF equipment separation
Classified MX Debrief & FSR office			1 private office + 3 cubicles + gear storage
Airfield Ops Admin			
LVC Support			Live, virtual constructive training support
Mission Planning Space, Airfield Ops AGRs			5 full time + additional mission planning support/eqpt separation
Classified Main Briefing Room			Seating for 60
Storage for Classified Items/Media			
Communications Support/Comm Closet			See example layout
Support	0	189	Net SF
Break Area			

PPE Training Bag Storage			1.5 SF/Person
Subtotal	60	13,672	Net SF
25% Overhead		3,418	
Subtotal		17,090	
Functional Standard		17,100	Gross SF
	22	2,000	CATCODE 140-422, see below
Functional Standard	82	19,100	Gross SF, Total both CATCODEs, since collocated listed together

1
2
3
4
5
6
7
8
9
10

NOTES:

1. Intel personnel have moved to CATCODE 140-422, see below.
2. Part of this standard was originally under CATCODE 218-852, Survival Equipment Shop which has been deleted and merged with this function
3. Add 600 SF for Optimizing the Human Weapon System (OHWS) at Combat Air Forces (CAF) locations only and only when assigned and activated with supporting trainer.
4. Flight scheduling, Flight Data Management, Airfield Operations and Weather are located in [CATCODE 141-453, Base Operations](#).

SCIF - Flying Wing (CatCode 140-422)	22	1,844	Net SF
Senior Intelligence Officer			
Intell Superintendent - share with Officer			
Intelligence Officer			
Intelligence NCO			
AFSCI Mission Planning Room			Mission Planning
SSO/ISSO			
Mantrap			
Comm Closet for SCIF			Per R. Wooten A2/6, see Rosecrans
Subtotal	22	1,844	
10% Overhead		184	
Subtotal		2,028	
Functional Standard		2,000	Gross SF

11
12
13

5.12.6 Squadron Operations, F-22 / F-35 Fighter Aircraft, 88 Personnel

Table 5-20: CATCODE 141-753, Sqd Ops, F-22 / F-35, 88 Personnel

Major Functions & Breakouts	Authorized Staffing	Target Area (SF)	Remarks
Command & Administration	9	1,934	Net SF
Group Commander	1		
Group Superintendent	1		
Training & Testing			See Chapter 1
Conference & Meeting			See Chapter 1
Orderly Room – Information Management Specialist	6		
Stan / Eval Officer	1		
T.O. Library			
Fighter Squadron	33	1,584	Net SF
Commander	1		
Admin Support – Information Mngmt Specialist	1		
Duty Desk	3		
Flight Surgeon	1		
Medical Staff	2		
Director of Operations	1		
Assistant Director of Operations	1		
A, B, C, D Flight Commanders	4		
Pilots	4		Cubicles
Pilots	14		Hoteling Stations
Flight Safety Officer	1		
Aircrew Flight Equipment	16	5,149	Net SF – See Note 1
Superintendent	1		
Flight Equipment Inspection	2		
Helmet / Oxygen Mask Repair	1		
Survival Training			
Dingy Room – Life Raft / Life Preserver Mx & Storage	2		
Fabrication / Parachute Packing Room	4		
Survival Kit / Seat Kit Packing	2		
Chemical Warfare Storage & Inspection	1		
Laundry / Wash Room			
AERP Maintenance & Storage	1		
ACCA Storage			
NVG Training & Maintenance	1		
JHMCS / ECI / IFF Maintenance & Storage			
Jump Suite Storage			
Aircrew Personalized Equipment Storage Lockers	1		10 SF/Person (24"x24" locker with circulation)
Operations Support Flight	12	1072	Net SF
Commander	1		
Admin Support – Information Mngmt Specialist	1		

Training Officer	1		
Unit Education Officer	1		
Unit Education / Training Manager	1		
Airfield Operations	3		
Flight Records	2		
Current Operations	2		
Secure Area / Vault	17	4,008	Net SF
Intelligence Officer	1		
ALIS	4		
Secure Comm Room			
Mission Planning Officer	4		
Targeting Analyst	3		
Fusion Analysis	5		Large planning tables, map racks, etc.
Brief/Debrief Rooms (5)			5 Each – seating for 8
Classified Main Briefing Room			Seating for 25
Vault - WTT/UTD/CFT			ACC Standard
Vault Lockers			
Communications Support			ACC Standard
Support	0	238	Net SF
Break Area			
PPE Training Bag Storage			1.5 SF/Person
Subtotal		13,985	Net SF
25% Overhead		3,496	
Subtotal		17,481	
Functional Standard		17,500	Gross SF

NOTES:

1. Units that have the Embedded Combat Weather Team are authorized an additional 950 Gross SF under [CATCODE 171-443, Reserve Forces General Training Support](#) to support this function.
2. Add 600 SF for Optimizing the Human Weapon System (OHWS) at Combat Air Forces (CAF) locations only and only when assigned and activated with supporting trainer.
3. Flight Scheduling, Flight Data Management, Airfield Operations and Weather are located in [CATCODE 141-453, Base Operations](#).
4. Part of this standard was originally under CATCODE 218-852, Survival Equipment Shop which has been deleted and merged into the Aircrew Flight Equipment function.

1
 2
 3
 4
 5
 6
 7
 8
 9
 10

1 5.12.7 Squadron Operations, Airlift, C-130, 153 Personnel

2 **Table 5-21: CATCODE 141-753, Sqd Ops, C-130, 153 Personnel**

Major Functions & Breakouts	Authorized Staffing	Target Area (SF)	Remarks
Command & Administration	12	2,540	Net SF
Group Commander	1		
Group Deputy CC	1		
Conference & Meeting			
Training & Testing			See Chapter 1
Orderly Room/Admin/IM/Personnel	2		See Chapter 1
Stan/Eval Officer	3		
Stan/Eval Superintendent	2		
Tech Order Library			
Group Chief	1		
Medical Suite	3		
Operations - Airlift Squadron	97	2,440	Net SF
Commander	1		
Orderly Room/Admin/IM/Personnel	2		
Director of Operations	1		
Assistant Director of Operations	1		
Duty Desk	2		
A, B, C, D, & E Flight Commanders	5		
Pilots/Navigators	37		
Chief Flight Engineer	1		
Engineers	15		
Chief Loadmaster	1		
Loadmaster Supervisors	3		
Loadmasters	28		
Aircrew Flight Equipment	16	6,552	Net SF- See Note 1
Superintendent	1		
Flight Equipment Inspection	2		
APE TO Library/hotel station			
Helmet/Oxygen Mask Repair	2		
Weapons Storage & Issue			
NVG Maint.			
CSEL Radio Maintenance			
Aircrew Survival Training			
Dingy Room – Life Raft/Life Preserver Maintenance & Storage	2		
Sewing/Fabrication Area	2		
Parachute Packing/Storage Area	2		
Survival Kit Packing	1		
Chemical Warfare Storage & Inspection	2		

Hazmat Storage			
Laundry/Wash Room			
Aircrew Personalized Equipment Storage Lockers	2		
Addenda A/AFE Gear Storage			
Operations Support Flight	16	1,804	Net SF
Commander	1		
Deputy Commander	1		
Operations Support Superintendent	1		
Administration Support – Information Management Specialist	1		
Training Officer	1		
Current Operations Manager	1		
Current Operations Officer	1		
Current Operations	2		
Current Operations Planning Room			
Schedulers	4		
Aviation Resources Management (ARMs)	3		
Secure Area / Vault	12	2,162	Net SF
Intelligence Officer	1		
Weapons & Tactics	4		
Plans Officer	1		
Mission Planning Officer	1		
Mission Planning NCOIC	1		
Mission Planning Staff	4		
Brief/Debrief Rooms (3)			3 Each – Seating for 8
Classified Main Briefing Room			Seating for 25 personnel
Vault			
Vault Lockers			
Support	0	328	Net SF
Break Area			
PPE Training Bag Storage			
Subtotal		15,826	Net SF
25% Overhead		3,957	
Subtotal		19,783	
Functional Standard		19,800	Gross SF

- 1 NOTES:
- 2 1. Units that have the Embedded Combat Weather Team are authorized an additional 950 Gross SF under
- 3 [CATCODE 171-443, Reserve Forces General Training Support](#) to support this function.
- 4 2. Flight Scheduling, Flight Data Management, Airfield Operations and Weather are located in [CATCODE 141-](#)
- 5 [453, Base Operations](#)
- 6 3. Part of this standard was originally under CATCODE 218-852, Survival Equipment Shop which has been
- 7 deleted and merged into the Aircrew Flight Equipment function.
- 8

1 5.12.8 Squadron Operations, Airlift, C-130J, 123 Personnel

2 **Table 5-22: CATCODE 141-753, Sqd Ops, C-130J, 123 Personnel**

Major Functions & Breakouts	Authorized Staffing	Target Area (SF)	Remarks
Command & Administration	11	2,280	Net SF
Group Commander	1		
Group Superintendent	1		
Conference & Meeting			See Chapter 1
Training & Testing			See Chapter 1
Orderly Room / Administration Support	2		
Stan / Eval Officer	2		
Stan / Eval Superintendent	1		
Medical Officer	1		
Medical Suite	3		
T.O. Library			
Operations - Airlift Squadron	70	1,956	Net SF
Commander	1		
Orderly Room / Administration Support	2		
Director of Operations	1		
Assistant Director of Operations	1		
Duty Desk	3		
A, B, & C Flight Commanders	3		
Pilots / Navigators	28		
Chief Loadmaster	1		
Loadmaster Supervisors	3		
Loadmasters	27		
Aircrew Flight Equipment	14	5,979	Net SF- See Note 1
Superintendent	1		
Flight Equipment Inspection	2		
Helmet / Oxygen Mask Repair	2		
Aircrew Survival Training			
Flotation Room – Raft / Preserver Mx & Storage	2		
Sewing / Fabrication Area	2		
Parachute Packing / Storage Area	2		
Survival Kit Packing	1		
Chemical Warfare Storage & Inspection	2		
Laundry / Wash Room			
Aircrew Personalized Equipment Storage Lockers			10 SF Each
NVG Maintenance			

Major Functions & Breakouts	Authorized Staffing	Target Area (SF)	Remarks
Weapons Storage & Issue			
Addenda A/AFE Gear Storage			
Operations Support Flight	16	1,692	Net SF
Commander	1		
Deputy Commander	1		
Operations Support Superintendent	1		
Administration Support	1		
Training Officer	1		
Current Operations Manager	1		
Current Operations Officer	1		
Current Operations	2		
Current Operations Planning Room			
Schedulers	4		
Aviation Resources Management (ARMs)	3		
Secure Area / Vault	12	2,562	Net SF
Intelligence Officer	1		
Weapons & Tactics	4		
Plans Officer	1		
Mission Planning Officer	1		
Mission Planning NCOIC	1		
Mission Planning Staff	4		
Brief / Debrief Rooms (3)			3 Each – Seating for 8
Classified Main Briefing Room			Seating for 25 personnel
Vault			
Vault Lockers			
Support	0	285	Net SF
Break Area			
PPE Training Bag Storage			
Subtotal		14,754	Net SF
25% Overhead		3,689	
Subtotal		18,443	
Functional Standard		18,400	Gross SF

NOTES:

1. Units that have the Embedded Combat Weather Team are authorized an additional 950 Gross SF under [CATCODE 171-443, Reserve Forces General Training Support](#) to support this function.
2. Flight Scheduling, Flight Data Management, Airfield Operations and Weather are located in [CATCODE 141-453, Base Operations](#)
3. Part of this standard was originally under CATCODE 218-852, Survival Equipment Shop which has been deleted and merged into the Aircrew Flight Equipment function.

1
 2
 3
 4
 5
 6
 7
 8

5.12.9 Squadron Operations, Airlift, C-17, 186 Personnel

Table 5-23: CATCODE 141-753, Sqd Ops, C-17, 186 Personnel

Major Functions & Breakouts	Authorized Staffing	Target Area (SF)	Remarks
Command & Administration	7	2,156	Net SF
Group Commander	1		
Deputy Commander	1		
Group Chief	1		
Training & Testing			See Chapter 1
Conference & Meeting			See Chapter 1
Orderly Room/Admin Supt/IM/Personnel	1		
Stan / Eval Officer	1		
Stan / Eval Superintendent	2		
T.O. Library			
Operations - Airlift Squadron	131	2,980	Net SF
Commander	1		
Orderly Room/Admin Spt/IM/Personnel	2		
Director of Operations	1		
Assistant Director of Operations	1		
Duty Desk	3		
A, B, & C Flight Commanders	3		
Pilots / Navigators	12		Workstations
Pilots / Navigators	48		Hoteling Stations
Loadmaster Supervisors	5		
Loadmasters	50		24 Hoteling Stations
Operations Resource Management	5		
Aircrew Flight Equipment	20	8,292	Net SF- See Note 1
Superintendent	1		
Flight Equipment Inspection	2		
APE TO Library/hotel station			
Helmet/Oxygen Mask Repair	2		
NVG Mx/Insp/Testing	1		
CSEL Radio Maintenance	1		
Aircrew Survival Training			
Life Raft/Life Preserver Mx & Storage	2		
Sewing/Fabrication Area	2		
Parachute Packing/Storage Area	2		
Survival Kit Packing	2		
Chemical Warfare Storage & Inspection	2		5 SF/Person
Hazmat Storage			

Laundry/Wash Room			
Aircrew Personalized Equip Strg Lockers	3		10 SF/Person
Addenda A Equipment Storage			
Operations Support Flight	15	1,928	Net SF
Commander	1		
Deputy Commander	1		
Orderly Room / Administration Support – Information Management Specialist & Personnel	2		
Training Officer	1		
Current Operations Manager	1		
Current Operations Officer	2		
Current Operations	5		
Current Operations Planning Room			
Operations Plans	2		
Secure Area / Vault	14	2,346	Net SF
Intelligence Officer	1		
Weapons & Tactics Officers	4		
Plans Officer	1		
Plans Staff	2		
Mission Planning Officer	1		
Mission Planning NCOIC	1		
Mission Planning Staff	4		
Brief / Debrief Rooms (3)			3 Each – seating for 8
Classified Main Briefing Room			Seating for 25 personnel
Vault			
Vault Lockers			
Support	0	390	Net SF
Break Area			
PPE Training Bag Storage			
Subtotal		18,092	Net SF
25% Overhead		4,523	
Subtotal		22,615	
Functional Standard		22,600	Gross SF

NOTES:

1. Units that have the Embedded Combat Weather Team are authorized an additional 950 Gross SF under [CATCODE 171-443, Reserve Forces General Training Support](#) to support this function.
2. Flight Scheduling, Flight Data Management, Airfield Operations and Weather are located in [CATCODE 141-453, Base Operations](#)
3. Part of this standard was originally under CATCODE 218-852, Survival Equipment Shop which has been deleted and merged into the Aircrew Flight Equipment function.

5.12.10 Squadron Operations C-38 / C-40, 72 Personnel

Table 5-24: CATCODE 141-753, Sqd Ops C-38 / C-40, 72 Personnel

Major Functions & Breakouts	Authorized Staffing	Target Area (SF)	Remarks
Airlift Squadron	66	2,322	Net SF
Director of Operations	1		
Training & Testing			See Chapter 1
Conference & Meeting			See Chapter 1
Flight Commanders	6		
Pilots	25		6 Hoteling Stations
Flight Crew Chief	1		
Flight Crews Supervisors	3		
Flight Crews	30		8 Hoteling Stations
Aircrew Flight Equipment	2	4,100	Net SF - See Note 1
Flight Equipment Inspection			
Helmet / Oxygen Mask Repair			
Survival Training			
Dingy Room – Life Raft / Life Preserver Maintenance & Storage			
Fabrication / Parachute Packing Room	1		
Survival Kit / Seat Kit Packing			
Laundry / Wash Room			
Aircrew Personalized Equipment Storage Lockers	1		66 Each
Operations Support Flight	4	1,656	Net SF
Safety Officer	1		
Current Operations Manager	1		
Current Operations Staff	2		
Secure Briefing Area			
Support		100	Net SF
Break Area			
Subtotal		8,178	Net SF
25% Overhead		2,045	
Subtotal		10,223	
Functional Standard		10,200	Gross SF

NOTES:

- Units that have the Embedded Combat Weather Team are authorized an additional 950 Gross SF under [CATCODE 171-443, Reserve Forces General Training Support](#) to support this function.
- Flight Scheduling, Flight Data Management, Airfield Operations and Weather are located in [CATCODE 141-453, Base Operations](#).
- Part of this standard was originally under CATCODE 218-852, Survival Equipment Shop which has been deleted and merged into the Aircrew Flight Equipment function.

5.12.11 Squadron Operations C-32, 48 Personnel

Table 5-25: CATCODE 141-753, Sqd Ops C-32, 48 Personnel

Major Functions & Breakouts	Authorized Staffing	Target Area (SF)	Remarks
Command & Administration	5	1,258	Net SF
Commander	1		
Aircraft Mx Officer	1		
Superintendent	1		
Conference & Meeting		450	See Chapter 1
Training & Testing		220	See Chapter 1
Aviation Resource Mngr	1		
Orderly Room/Administration Support	1		
Tech Order Library			
Operations Flight	18	1,984	Net SF
OIC	1		
Ops Officer	2		
Pilots	15		7 cubicles, 8 hoteling
SIPR Station			
Mission Planning			4 planning stations
Brief/Debrief Rooms			2 @ 192 SF each, seating for 8
Airborne Mission System	12	544	Net SF
NCOIC	1		
Mission Planning	4		
Airborne Communications	7		
Aircraft Loadmasters	12	528	Net SF
NCOIC	1		
Load Plans Cargo/Passenger	6		
Preflight/ Post-flight	6		
Aircrew Flight Element	1	644	Net SF
Mission Support Specialists	1		
Life Support			
AFE Storage Lockers			38 Aircrew @ 10 SF/person
Support	0	160	Net SF
Break Area			
PPE Training Bag Storage			1.5 SF/Person
Subtotal		5,118	Net SF
25% Overhead		1,280	
Subtotal		6,398	
Functional Standard	48	6,400	Gross SF

NOTES:

- Flight Scheduling, Flight Data Management, Airfield Operations and Weather are located in [CATCODE 141-453, Base Operations](#).
- Part of this standard was originally under CATCODE 218-852, Survival Equipment Shop which has been deleted and merged into the Aircrew Flight Equipment function.

1 5.12.12 Squadron Operations, KC-135 One Squadron, 119 Personnel

2 **Table 5-26: CATCODE 141-753, Sqd Ops, KC-135 One Sqd, 119 Personnel**

Major Functions & Breakouts	Authorized Staffing	Target Area (SF)	Remarks
Command & Administration	10	2,160	Net SF
Group Commander	1		
Group Superintendent	1		
Conference & Meeting			See Chapter 1
Training & Testing			See Chapter 1
Orderly Room/Administration Support	2		
Stan/Eval Officer	2		
Stan/Eval Superintendent	1		
Medical Suite	3		
Tech Order Library			
Air Refueling Squadron	71	1,808	Net SF
Commander	1		
Orderly Room / Administration Support – Information Management Specialist & Personnel	2		
Director of Operations	1		
A, B, & C Flight Commanders	3		
Pilots / Navigators	41		Hoteling Stations
Chief Boom Operator	1		
Boom Operator Supervisors	3		
Boom Operators	17		Hoteling Stations
Aircrew Resource Management (ARMS)	2		
Aircrew Flight Equipment	12	5,722	Net SF – See Note 2
Superintendent	1		
NCOIC/QA Office	2		
TO Library/Hotel Stations			
Centralized Aircrew Flight Equipment Shop	2		
Helmet/Oxygen Mask Repair	1		
Aircrew Training Room			
Flotation Room – Raft/Preserver Mx & Storage	2		
Sewing/Fabrication Area	1		
Survival Kit Packing	1		
ACBRN BOI, ACCA, TMDE and Mobility Storage	1		
Laundry/Wash Room			
Aircrew Personalized Equipment Storage Lockers			66 aircrew members x 10 SF/person
CSEL Radio Maintenance	1		
Addenda A Equipment Storage			
Operations Support Flight	13	1,388	Net SF
Commander	1		
Administration Support	1		
Training Officer	1		
Current Operations Chief	1		
Current Operations Officer	2		

Current Operations Staff	1		
Current Operations Planning Room			
Combat Crew Comm Superintendent	1		
Combat Crew Comm	2		
Ops Support Superintendent	1		
Ops Support	2		
Secure Area / Vault	13	3,187	Net SF
Senior Intel Officer	1		
Intel Officer	1		
Intel NCO	1		
Weapons & Tactics	3		
Plans Officer	1		
Mission Planning Officer	1		
Mission Planning NCOIC	1		
Mission Planning Space	4		4 planning stations, 1 mission planning table, 4 eval stations, & pubs shelving
Brief / Debrief Rooms (4)			4 @ 192 SF each – seating for 8
Classified Main Briefing Room			Seating for 50 personnel
Vault			
Vault Lockers			
Support	0	279	Net SF
Break Area			
PPE Training Bag Storage			
Subtotal		14,544	Net SF
25% Overhead		3,636	
Subtotal		18,180	
Functional Standard	119	18,200	Gross SF (See Note 1)

1
 2
 3
 4
 5
 6
 7
 8
 9

NOTES:

- Units that have the Embedded Combat Weather Team are authorized an additional 950 Gross SF under [CATCODE 171-443, Reserve Forces General Training Support](#) to support this function.
- Flight Scheduling, Flight Data Management, Airfield Operations and Weather are located in [CATCODE 141-453, Base Operations](#).
- Part of this standard was originally under CATCODE 218-852, Survival Equipment Shop which has been deleted and merged into the Aircrew Flight Equipment function.

5.12.13 Squadron Operations, KC-135 One Sqd (Active Association), 138 Personnel

Table 5-27: CATCODE 141-753, Sqd Ops, KC-135 One Sqd (Active Association), 138 Personnel

Major Functions & Breakouts	Authorized Staffing	Target Area (SF)	Remarks
Command & Administration	15	2,346	Net SF
Group Commander	1		
Group Superintendent	1		
First Sergeant	1		
Conference & Meeting			See Chapter 1
Training & Testing			See Chapter 1
Orderly Room/Administration Support	4		
Stan/Eval Officer	3		
Stan/Eval Superintendent	2		
Tech Order Library			
Air Refueling Squadron	70	2,116	Net SF
Commander	2		
Orderly Room / Administration	2		
Director of Operations	2		
A, B, & C Flight Commanders	3		
Pilots / Navigators	36		Hoteling Stations
Chief Boom Operator	1		
Boom Operator Supervisors	4		
Boom Operators	17		Hoteling Stations
Aircrew Resource Management (ARMS)	3		
Aircrew Flight Equipment	15	6,278	Net SF – See Note 2
Superintendent	1		
NCOIC/QA Office	2		
TO Library/Hotel Stations			
Centralized Aircrew Flight Equipment Shop	5		
Helmet/Oxygen Mask Repair	1		
Aircrew Training Room			
Flotation Room – Raft/Preserver Mx & Storage	2		
Sewing/Fabrication Area	1		
Survival Kit Packing	1		
ACBRN BOI, ACCA, TMDE and Mobility Storage	1		
Laundry/Wash Room			
Aircrew Personalized Equipment Storage Lockers			86 aircrew members x 10 SF/person
CSEL Radio Maintenance	1		
Addenda A Equipment Storage			
Operations Support Flight	17	1,794	Net SF
Commander	1		
Administration Support	1		
Training Officer	2		
Current Operations Chief	1		
Current Operations Officer	3		
Current Operations Staff	2		
Current Operations Planning Room			
Combat Crew Comm Superintendent	1		
Combat Crew Comm	3		
Ops Support Superintendent	1		
Ops Support	2		
Secure Area / Vault	13	3,190	Net SF

Senior Intel Officer	1		
Intel Officer	1		
Intel NCO	1		
Weapons & Tactics	3		
Plans Officer	1		
Mission Planning Officer	1		
Mission Planning NCOIC	1		
Mission Planning Space	4		4 planning stations, 1 10'x5' mission plg table, 4 eval stations, & pubs shelving
Brief / Debrief Rooms (4)			4 @ 192 SF each – seating for 8
Classified Main Briefing Room			Seating for 50 personnel
Vault			
Vault Lockers			
Support	0	307	Net SF
Break Area			
PPE Training Bag Storage			
Subtotal		16,031	Net SF
25% Overhead		4,008	
Subtotal		20,039	
Functional Standard		20,000	Gross SF

1
 2
 3
 4
 5
 6
 7
 8
 9

NOTES:

- Units that have the Embedded Combat Weather Team are authorized an additional 950 Gross SF under [CATCODE 171-443, Reserve Forces General Training Support](#) to support this function.
- Flight Scheduling, Flight Data Management, Airfield Operations and Weather are located in [CATCODE 141-453, Base Operations](#).
- Part of this standard was originally under CATCODE 218-852, Survival Equipment Shop which has been deleted and merged into the Aircrew Flight Equipment function.

5.12.14 Squadron Operations, KC-135 Two Squadrons, 178 Personnel

Table 5-28: CATCODE 141-753, Sqd Ops, KC-135 Two Sqdns, 178 Personnel

Major Functions & Breakouts	Authorized Staffing	Target Area (SF)	Remarks
Command & Administration	8	2,108	Net SF
Group Commander	1		
Training & Testing			See Chapter 1
Conference & Meeting			See Chapter 1
Orderly Room / Administration Support	2		
Stan / Eval Manager	1		
Stan / Eval Officer	3		
Stan / Eval Superintendent	1		
T.O. Library			
Air Refueling Squadron #1	56	1,336	Net SF
Commander	1		
Orderly Room / Administration Support	2		
Director of Operations	1		
A, B & C Flight Commanders	3		
Pilots / Navigators	30		8 Hoteling Stations
Chief Boom Operator	1		
Boom Operator Supervisors	2		
Boom Operators	14		4 Hoteling Stations
Operations Resource Management	2		
Air Refueling Squadron #2	56	1,336	Net SF
Commander	1		
Orderly Room / Administration Support	2		
Director of Operations	1		
A, B & C Flight Commanders	3		
Pilots / Navigators	30		30 Hoteling Stations
Chief Boom Operator	1		
Boom Operator Supervisors	2		
Boom Operators	14		4 Hoteling Stations
Operations Resource Management	2		
Aircrew Flight Equipment #1	13	4,319	Net SF – See Note 1
Superintendent	1		
Flight Equipment Inspection	1		Torso harnesses / flight suits
Helmet / Oxygen Mask Repair	2		
Survival Training			
Dingy Room - Life Raft / Life Preserver Maintenance & Storage	2		
Sewing / Fabrication Area	1		
Parachute Packing / Storage Area	2		
Survival Kit Packing	1		
Chemical Warfare Storage & Inspection	1		
Laundry / Wash Room			
Aircrew Personalized Equipment Storage Lockers	2		50 Each
Aircrew Flight Equipment #2	13	4,319	Net SF– See Note 1
Superintendent	1		
Flight Equipment Inspection	1		Torso harnesses / flight suits
Helmet / Oxygen Mask Repair	2		
Aircrew Survival Training			
Flotation Room – Raft/Preserver Mx & Storage	2		
Sewing / Fabrication Area	1		
Parachute Packing / Storage Area	2		
Survival Kit Packing	1		
Chemical Warfare Storage & Inspection	1		
Laundry / Wash Room			

Aircrew Personalized Equipment Storage Lockers	2		50 Each
Operations Support Flight	15	2,504	Net SF
Commander	1		
Administration Support – Information Management Specialist	1		
Training Officer	1		
Current Operations Chief	1		
Current Operations Officer	2		
Current Operations Officer	2		
Current Operations Staff	1		
Current Operations Planning Rooms (2)			Two rooms with large planning tables, map racks, etc.
Combat Crew Communication Superintendent	1		
Combat Crew Communication	2		
Operations Support Superintendent	1		
Operations Support	2		
Secure Area / Vault	17	2,791	Net SF
Intelligence Officer	1		
Weapons & Tactics	2		
Weapons & Tactics	1		
Plans Officer	1		
Mission Planning Officer	3		
Mission Planning NCOIC	1		
Mission Planning Staff	8		
Brief / Debrief Rooms (4)			4 Each
Classified Main Briefing Room			
Vault Lockers			
Vault			
Common Areas	0	367	Net SF
Break Area			
PPE Training Bag Storage			
Subtotal		19,080	Net SF
25% Overhead		4,770	
Subtotal		23,850	
Functional Standard		23,900	Gross SF

1
 2
 3
 4
 5
 6
 7
 8
 9

NOTES:

- Units that have the Embedded Combat Weather Team are authorized an additional 950 Gross SF under [CATCODE 171-443, Reserve Forces General Training Support](#) to support this function.
- Flight Scheduling, Flight Data Management, Airfield Operations and Weather are located in [CATCODE 141-453, Base Operations](#).
- Part of this standard was originally under CATCODE 218-852, Survival Equipment Shop which has been deleted and merged into the Aircrew Flight Equipment function.

1 5.12.15 Squadron Operations, KC-46 One Sqd 12PAA (Active Association), 230 Personnel

2 **Table 5-29: CATCODE 141-753, Sqd Ops, KC-46 One Sqd 12PAA (Active Association), 230 Personnel**

Major Functions & Breakouts	ANG Staffing	AA Staffing	Target Area (SF)	Remarks
Command & Administration	17	17	4,286	Net SF
Group Commander				
Group Superintendent				
Conference & Meeting				See Chapter 1
Training & Testing				See Chapter 1
Orderly Room/Administration Support				
Stan/Eval Officer				
Stan/Eval Superintendent/Boom Ops				
Current Operations				
Readiness				
Flight Medicine				
Tech Order Library				
Air Refueling Squadron	99	35	5,712	Net SF
Commander				
Operations Officer				
First Sergeant				
Orderly Room/Administration Support				
Education & Training				
Forces				
A, B, & C Flight Commanders				
Pilots LtCol positions				
Pilots ANG				Hoteling Stations
Pilots AA				
Chief Boom Operator				
Boom Operators ANG				Hoteling Stations
Boom Operators AA				
Scheduling				
Aircrew Flight Equipment	12	3	7,472	Net SF- See Note 1
Superintendent				
NCOIC/QA Office				
TO Library/Hotel Stations				
Centralized Aircrew Flight Equipment Shop				
Helmet/Oxygen Mask Repair				
Aircrew Training Room				
Flotation Room – Raft/Life Preserver Mx & Storage				
Sewing/Fabrication Area				
Survival Kit Packing				
ACBRN BOI, ACCA, TMDE and Mobility Storage				
Laundry/Wash Room				
Aircrew Personalized Equipment Storage Lockers				
NVG Maint.				
Weapons Storage and Issue				
CSEL Radio Maintenance				
Munitions and Hazmat Storage				
Addenda A Equipment Storage				
Operations Support Squadron	21	3	2,390	Net SF
Commander	1			
Administration Support – Information Management	1			
Current Operations Chief				
Flight Commander				
Current Operations Officer				
Ops Support Superintendent				

Ops Support NCO				
Training Officer	2			
Training NCOs	1			
Current Operations Planning Room	1			
ARMS	2			
Secure Area / Vault	27	3	4,456	Net SF
Intelligence Flight CC				
Intel Officers				
Intel NCOs				
Weapons & Tactics				
Operations Plans				
Combat Crew Comm Superintendent				
Combat Crew Comm				
Mission Planning				769 for 36 aircraft
Brief/Debrief Rooms (4)				4 Each – seating for 8
Classified Main Briefing Room				Seating for 50 Personnel
Secure Storage				
Vault Lockers				
Support	0		453	Net SF
Break Area				
PPE Training Bag Storage				
Subtotal			24,770	Net SF
25% Overhead			6,193	
Subtotal			30,963	
Functional Standard			31,000	Gross SF

1
 2
 3
 4
 5
 6
 7
 8
 9

NOTES:

- Units that have the Embedded Combat Weather Team are authorized an additional 950 Gross SF under [CATCODE 171-443, Reserve Forces General Training Support](#) to support this function.
- Flight Scheduling, Flight Data Management, Airfield Operations and Weather are located in [CATCODE 141-453, Base Operations](#).
- Part of this standard was originally under CATCODE 218-852, Survival Equipment Shop which has been deleted and merged into the Aircrew Flight Equipment function.

5.12.16 Squadron Operations, KC-46 One Sqd 12PAA, 228 Personnel

Table 5-30: CATCODE 141-753, Sqd Ops, KC-46 One Sqd 12PAA, 228 Personnel

Major Functions & Breakouts	ANG Staffing	Target Area (SF)	Remarks
Command & Administration	21	3,508	Net SF
Group Commander			
Group Superintendent			
Conference & Meeting			See Chapter 1
Training & Testing			See Chapter 1
Orderly Room/Admin Sup – Information Management Specialist			
Stan/Eval Officer			
Stan/Eval Superintendent/Boom Ops			
Current Operations			
Readiness			
Flight Medicine			
Tech Order Library			
Air Refueling Squadron	137	3,856	Net SF
Commander			
Operations Officer			
First Sergeant			
Orderly Room/Admin Sup – Information Management Specialist			
Education & Training			
Forces			
A, B, & C Flight Commanders			
Pilots LtCol positions			
Pilots			Hoteling Stations
Pilots			
Chief Boom Operator			
Boom Operators			Hoteling Stations
Boom Operators			
Scheduling			
Aircrew Flight Equipment	18	7,164	Net SF- See Note 1
Superintendent			
NCOIC/QA Office			
TO Library/Hotel Stations			
Centralized Aircrew Flight Equipment Shop			
Helmet/Oxygen Mask Repair			
Aircrew Training Room			
Flotation Room – Life Raft/Life Preserver Maintenance & Storage			
Sewing/Fabrication Area			
Survival Kit Packing			
ACBRN BOI, ACCA, TMDE and Mobility Storage			
Laundry/Wash Room			
Aircrew Personalized Equipment Storage Lockers			
NVG Maint.			
Weapons Storage and Issue			
CSEL Radio Maintenance			
Munitions and Hazmat Storage			
Addenda A Equipment Storage			
Operations Support Squadron	37	3,406	Net SF
Commander			
Administration Support – Information Management Specialist			
Current Operations Chief			

Flight Commander			
Current Operations Officer			
Ops Support Superintendent			
Ops Support NCO			
Training Officer			
Training NCOs			
Current Operations Planning Room			
ARMS			
Secure Area / Vault	15	2,710	Net SF
Intelligence Flight CC			
Weapons & Tactics			
Operations Plans			
Mission Planning			
Brief/Debrief Rooms (4)			3 Each – seating for 8
Classified Main Briefing Room			Seating for 50 Personnel
Secure Storage			
Vault Lockers			
Support	0	442	Net SF
Break Area			
PPE Training Bag Storage			
Subtotal		21,086	Net SF
25% Overhead		5,272	
Subtotal		26,358	
Functional Standard	228	26,400	Gross SF

1
 2
 3
 4
 5
 6
 7
 8
 9

NOTES:

4. Units that have the Embedded Combat Weather Team are authorized an additional 950 Gross SF under [CATCODE 171-443, Reserve Forces General Training Support](#) to support this function.
5. Flight Scheduling, Flight Data Management, Airfield Operations and Weather are located in [CATCODE 141-453, Base Operations](#).
6. Part of this standard was originally under CATCODE 218-852, Survival Equipment Shop which has been deleted and merged into the Aircrew Flight Equipment function.

5.12.17 Squadron Operations, KC-46 One Sqd 8PAA(Active Association), 177 Personnel

Table 5-31: CATCODE 141-753, Sqd Ops, KC-46 One Sqd 8PAA (Active Association), 177 Personnel

Major Functions & Breakouts	ANG Staffing	AA Staffing	Target Area (SF)	Remarks
Command & Administration	15	7	3,388	Net SF
Group Commander				
Group Superintendent				
First Sergeant				
Conference & Meeting				See Chapter 1
Training & Testing				See Chapter 1
Orderly Room/Admin Sup – Information Management Specialist				
Stan/Eval Officer				
Stan/Eval Superintendent/Boom Ops				
Medical Suite				
Tech Order Library				
Air Refueling Squadron	75	27	2,444	Net SF
Commander				
Operations Officer				
Orderly Room/Admin Sup – Information Management Specialist				
Education & Training				
Forces				
A, B, & C Flight Commanders				
Pilots				Hoteling Stations
Chief Boom Operator				
Boom Operators				Hoteling Stations
Scheduling				
Aircrew Flight Equipment	13	3	7,008	Net SF- See Note 1
Superintendent				
NCOIC/QA Office				
TO Library/Hotel Stations				
Centralized Aircrew Flight Equipment Shop				
Helmet/Oxygen Mask Repair				
Aircrew Training Room				
Flotation Room – Life Raft/Life Preserver Maintenance & Storage				
Sewing/Fabrication Area				
Survival Kit Packing				
ACBRN BOI, ACCA, TMDE and Mobility Storage				
Laundry/Wash Room				
Aircrew Personalized Equipment Storage Lockers				
Weapons Storage and Issue				
CSEL Radio Maintenance				
Munitions and Hazmat Storage				
Addenda A Equipment Storage				
Operations Support Squadron	19	0	1,978	Net SF
Commander				
Administration Support – Information Management Specialist				
Training Officer				
Current Operations Chief				
Current Operations Officer				
Current Operations Staff				
Current Operations Planning Room				
Combat Crew Comm Superintendent				
Combat Crew Comm				

Ops Support Superintendent				
Ops Support Staff				
Secure Area / Vault	15	3	3,510	Net SF
Senior Intel Officer				
Intel Officer				
Intel NCO				
Weapons & Tactics				
Airfield Operations				4 planning stations, 1 10'x5' mission planning table, 4 eval stations, and pubs shelving
Mission Planning Space				4 Each – seating for 8
Mass Briefing				Seating for 32 Personnel
Vault				
Vault Lockers				
Support	0		366	Net SF
Break Area				
PPE Training Bag Storage				
Subtotal			18,694	Net SF
25% Overhead			4,673	
Subtotal			23,367	
Functional Standard	137	40	23,400	Gross SF

1
 2
 3
 4
 5
 6
 7
 8
 9

NOTES:

7. Units that have the Embedded Combat Weather Team are authorized an additional 950 Gross SF under [CATCODE 171-443, Reserve Forces General Training Support](#) to support this function.
8. Flight Scheduling, Flight Data Management, Airfield Operations and Weather are located in [CATCODE 141-453, Base Operations](#).
9. Part of this standard was originally under CATCODE 218-852, Survival Equipment Shop which has been deleted and merged into the Aircrew Flight Equipment function.

5.12.18 Squadron Operations, KC-46 One Sqd 8PAA, 149 Personnel

Table 5-32: CATCODE 141-753, Sqd Ops, KC-46 One Sqd 8PAA, 149 Personnel

Major Functions & Breakouts	Authorized Staffing	Target Area (SF)	Remarks
Command & Administration	9	2,162	Net SF
Group Commander	1		
Group Superintendent	1		
Conference & Meeting			See Chapter 1
Training & Testing			See Chapter 1
Stan/Eval OIC	2		
Stan/Eval Superintendent	1		
Tech Order Library			
Medical Suite	4		See Note 1
Air Refueling Squadron	96	2,186	Net SF
Commander	1		
Director of Operations	1		
A, B, & C Flight Commanders	3		
Pilots/Navigators	55		Hotel space = # aircrew x 50% x 24 SF/Person
Chief Boom Operator	3		
Boom Operators	32		Hotel space = # aircrew x 50% x 24 SF/Person
Aircrew Resource Management (ARMS)	1		Plus ARMS Storage
Aircrew Flight Element	14	6,016	Net SF (See Note 2)
Superintendent	1		
NCOIC/QA Office	2		
TO Library/Hotel Stations			Hotel space = # personnel x 50% x 24 SF/Person
Centralized Aircrew Flight Equipment Shop	2		Combined with Helmet/Oxygen Mask Repair
Helmet/Oxygen Mask Repair	2		As requested, combined as per the notes
Aircrew Training Room			
Life Preserver Maintenance & Storage	2		Increased for 10 person raft area
Sewing/Fabrication Area	1		Need justification on this line
Survival Kit Packing	1		
ACBRN BOI, ACCA, TMDE and Mobility Storage	1		Suggest space saver solution
Laundry/Wash Room			
Aircrew Personalized Equipment Storage Lockers			Requested 111 aircrew members x 10 SF/person
NVG Maint.	1		Requested is to combine
Weapons Storage and Issue			
CSEL Radio Maintenance	1		combined with NVG Maint as per the notes.
Munitions and Hazmat Storage			
Addenda A Equipment Storage			25 seat pallets
Operations Support Flight	15	1,674	Net SF
Commander	1		
Training Officer	2		
Current Operations Officer	2		
Current Operations Superintendent	1		
Current Operations Staff	4		Hoteling

Current Operations Planning Room			
Combat Crew Comm	3		
Aviation Resource Management	2		
Secure Area/Vault	15	2,483	Net SF
Senior Intel Officer	1		
Intel Officer	2		
Intel	7		Hoteling
Weapons & Tactics	1		
Airfield Operations Officer	1		
Airfield Operations	3		
Brief/Debrief Rooms			3 @ 192 SF each – seating for 8
Classified Main Briefing Room			Seating for 50 Personnel
Secure Storage			
Vault Lockers			
Support	0	324	Net SF
Break Area			
PPE Training Bag Storage			1.5 SF/Person
Subtotal		14,845	Net SF
25% Overhead		3,711	
Subtotal		18,556	
Functional Standard	149	18,600	Gross SF

1
 2
 3
 4
 5
 6
 7
 8
 9

NOTES:

10. Units that have the Embedded Combat Weather Team are authorized an additional 950 Gross SF under [CATCODE 171-443, Reserve Forces General Training Support](#) to support this function.
11. Flight Scheduling, Flight Data Management, Airfield Operations and Weather are located in [CATCODE 141-453, Base Operations](#).
12. Part of this standard was originally under CATCODE 218-852, Survival Equipment Shop which has been deleted and merged into the Aircrew Flight Equipment function.

5.12.19 Squadron Operations, Rescue HC-130 / HH-60, 171 Personnel

Table 5-33: CATCODE 141-753, Sqd Ops, Rescue HC-130 /HH-60, 171 Personnel

Major Functions & Breakouts	Authorized Staffing	Target Area (SF)	Remarks
Command & Administration	14	2,660	Net SF
Group Commander	1		
Group Deputy CC	1		
Group Chief	1		
Training & Testing			See Chapter 1
Conference & Meeting			See Chapter 1
Orderly Room / Administration Support	1		
Stan / Eval Superintendent	1		
Stan / Eval Officer	2		
Stan / Eval Managers	2		
Stan / Eval Staff	5		
T.O. Library			
Operations Squadron – HC-130 Airlift Squadron	66	2,680	Net SF
Commander	1		
Orderly Room / Administration Support	2		
Director of Operations	1		
Flight Safety Officer	1		
Flight Commanders	3		
Pilots / Navigators	22		5 Hoteling Stations
Chief Flight Engineers	1		
Flight Engineers	6		
Chief Loadmasters	1		
Loadmasters	13		
Chief Airborne Mission Sys Specs (Radio operator)	1		
Airborne Mission Sys	7		
Aviation Resource Manager	3		
Materials Management	1		
Medical Suite	3		7 Hoteling Stations
Operations Squadron – HH-60 Helicopter Squadron	46	1,968	Net SF
Commander	1		
Orderly Room / Administration Support	1		
Director of Operations	1		

Major Functions & Breakouts	Authorized Staffing	Target Area (SF)	Remarks
Flight Safety Officer	1		
Flight Commanders	3		
Pilots	15		4 Hoteling Stations
Crew Chiefs	1		
Crew Supervisors	2		
Crew	17		4 Hoteling Stations
Aviation Resource Manager	3		
Materials Management	1		
Aircrew Flight Equipment	10	6,425	Net SF– See Note 1
Superintendent	1		
Flight Equipment Inspection	1		Torso harnesses / flight suits
Helmet / Oxygen Mask Repair	2		
Aircrew Survival Training	2		
Sewing / Fabrication Area	2		Main Sewing Area located PJ Bldg
Parachute Storage Area			Packing in PJ Bldg
Chemical Warfare Storage & Inspection	2		
Laundry / Wash Room			
Aircrew Personalized Equipment Storage Lockers			109 @ 14 SF/Person (36" w x 24" d locker and circulation)
Anti-Exposure Suit/TQT Don/Doff Room			
NVG Storage			
Addenda A/AFE Gear and Rescue Wing Sqd Ops specific equipment Storage			
Operations Support Flight	8	812	Net SF
Orderly Room / Administration Support	2		
Current Operations	3		
Flight Records	3		
Secure Area / Vault	27	4,904	Net SF
Chief Intelligence Officer	1		
Intelligence Officers	4		
Operations Intel/Fusion Analysis	8		
Chief Weapons & Tactics	1		
Weapons & Tactics	2		
Tactics Library			
Chief Operations Plans	1		
Operations Plans (OSX)	2		
Mission Planning Room			
Weapons Storage and Issue			

Major Functions & Breakouts	Authorized Staffing	Target Area (SF)	Remarks
HC-130 Brief/Debrief Rooms (2)			2 Each – seating for 8
HH-60 Brief/Debrief Rooms (2)			
Classified Briefing Room			
Counter Drug HH-60 Superintendent	1		
Counter Drug HH-60	7		
Vault Lockers			
Vault			
Support	0	358	Net SF
Break Area			
PPE Training Bag Storage			
Subtotal		19,807	Net SF
25% Overhead		4,952	
Subtotal		24,759	
Functional Standard	171	24,800	Gross SF

- 1 NOTES:
 2 1. Part of this standard was originally under CATCODE 218-852, Survival Equipment Shop which has been
 3 deleted and merged into the Aircrew Flight Equipment function.
 4

1 5.12.20 Squadron Operations, RPA, 213 Personnel

2 **Table 5-34: CATCODE 141-753, Sqd Ops, RPA, 213 Personnel**

Major Functions & Breakouts	Authorized Staffing	Target Area (SF)	Remarks
Command & Administration	7	2,168	Net SF
Group Commander	1		
Stan / Eval Officer	2		8 personnel
Stan / Eval NCO	2		
Operations Chief	1		
Training & Testing			See Chapter 1
Conference & Meeting			See Chapter 1
Information Management / Orderly Room	1		
Tactical Squadron Command Section	6	552	Net SF
Commander	1		
First Sergeant	1		
Operations Chief	1		
Intelligence Application & Exploitation Manager	1		
Information Management / Orderly Room	1		
Education & Training	1		
Tactical Operations	94	1,448	Net SF
Operations Officer	1		
Pilots	30		10 per shift
Sensor Operators (SO's) / Mission Monitors (MM's)	60		20 per shift
Medical Element	3		
Operations Support Squadron	106	5,016	Net SF
Commander	1		
First Sergeant	1		
Operations Chief	1		
Information Management / Orderly Room	3		
Operations Officer	1		
Operational Training	11		
Communication Support	24		
Intelligence Section	15		
Weapons & Tactics	4		
Current Operations	20		
Flight Data Management	5		
Operations Plans	3		

Major Functions & Breakouts	Authorized Staffing	Target Area (SF)	Remarks
Flying Operations Supervision (FOS)	1		
Mission Support Analyst (MSA)	1		
Communication Relay Hub (Servers/Personnel)	1		
Mission Intelligence Coordination (MIC)	1		
Weather Officer (Domestic Ops)	1		
Weather Officer	1		
Weather Team	6		
Special Security Office	5		
Secure Briefing Area			Sized for 25 personnel
Support	0	646	Net SF
Break Area			
PPE Training Bag Storage			
Reconstitution Area			
2 Showers/Changing Area			
Subtotal		9,830	Net SF
25% Overhead		2,458	
Subtotal		12,288	
Functional Standard		12,300	Gross SF

1
 2

5.12.21 Squadron Operations, CRTC, 52 personnel. This CATCODE provides the functional standard for one Squadron Operations facility. Each CRTC is authorized one 7,600 SF Squadron Operations facility for the cadre and one 7,600 SF Squadron Operations facility for visiting units. Total authorization is 15,200 SF for two separate facilities.

Table 5-35: CATCODE 141-753, Sqd Ops, CRTC, 52 personnel

Major Functions & Breakouts	Authorized Staffing	Target Area (SF)	Remarks
Command & Administration	4	1,362	Net SF
Group Commander	1		
Training & Testing			See Chapter 1
Conference & Meeting			See Chapter 1
Orderly Room / Admin	1		
First Sergeant	1		
Operations Officer			
Orderly Room / Admin	1		
Operations	12	824	Net SF
Squadron Commander	1		
Flight Commander	1		
Current Operations	2		
Flight Services / Flight Management	2		
Chief Pilot / Navigator / Engineer / Load Master	4		
Weather	2		
Secure Area	28	2,216	Net SF
Communications Security (COMSEC) Storage			
Class A Vaults	12		
LAN and SIPERNET Office	4		
Intel / Tactics / Mission Planning	12		
Flight Planning			
Aircrew Briefing Rooms			
Aircrew Flight Equipment	8	1,652	Net SF – See Note 1
Aircrew Flight Equipment OIC / Admin	2		
Aircrew Flight Equipment / Helmet / Mask / Bottle Storage	2		
Chief Pilot / Navigator / Engineer / Load Master	4		
Subtotal		6,054	Net SF
25% Overhead		1,514	
Subtotal		7,568	
Functional Standard		7,600	Gross SF

NOTE:

- Part of this standard was originally under CATCODE 218-852, Survival Equipment Shop which has been deleted and merged into the Aircrew Flight Equipment function.

1 5.12.22 Air Support Operations Group (ASOG), 39 Personnel. The ASOG is responsible for
 2 commanding, training, equipping, and evaluating units that support army corps and
 3 subordinate units. The ASOG also provides weather support, does tactical planning, and
 4 commands and controls all ANG units aligned with the associated army units.

5 **Table 5-36: CATCODE 141-753, Air Support Ops Group Admin, 39 Personnel**

Major Functions & Breakouts	Authorized Staffing	Target Area (SF)	Remarks
Command & Administration	7	1,632	Net SF
Commander	1		
Vice Commander	1		
Training & Testing			See Chapter 1
Conference & Meeting			See Chapter 1
Unit Manager / First Sergeant	1		
Executive Officer	1		
Orderly Room – Information Management Specialist	2		
Information Management Center			
T.O. Library			
Unit Education / Training Manager	1		
Operations	32	2,328	Net SF
Director of Operations	1		
Assistant Director of Operations	2		
Tactical Air Command & Control Specialists	9		
Intelligence Officer	1		
Intelligence Specialist	1		
Logistics	9		
Management Officer	1		
Personnel Specialist	1		
Maintenance Supervisor	1		
Maintenance Support	3		
Supply	1		
Radio Maintenance	1		
Vehicle Operations	1		
Support	0	159	Net SF
Break Area			
PPE Training Bag Storage			
Subtotal		4,119	Net SF
25% Overhead		1,030	
Subtotal		5,149	
Functional Standard		5,100	Gross SF

6

7

1 5.12.23 Air Support Operations Squadron (ASOS), **105 Personnel**. The ASOS performs liaison and
 2 control operations for the Air Force, and provides garrison weather support and close air
 3 support for army divisions, brigades, and battalions. In addition, it maintains mission-ready
 4 air support operations personnel and radios, vehicles, and mobility equipment deployable
 5 worldwide. The ASOS personnel conduct planning and training programs. ASOS
 6 personnel train with Army personnel and deploy with army units during training missions
 7 and contingency operations.

8 **Table 5-37: CATCODE 141-753, Air Support Ops Sqd, Admin, **85 Personnel****

Major Functions & Breakouts	Authorized Staffing	Target Area (SF)	Remarks
Command & Administration	5	1,672	Net SF
Commander	1		
First Sergeant	1		
Administrative Assistant	3		
Conference & Meeting			See Chapter 1
Training & Testing			See Chapter 1
Library			
Operations Support	14	1,120	Net SF
TACP Operations officer	2		
TACP Operations NCO	1		
Weapons and Tactics	4		
Training	5		
Standardization and Evaluation	2		
TACP MDC2	22	1,880	Net SF
TACP Cmd & Control	6		
MDO (DOZA)	2		
MDO Mission Control Team 1	4		
MDO Mission Control Team 2	5		
MDO Mission Control Team 3	5		
Crew Storage			
TACP 2 Flights (DOZB and DOZC)	44	3,860	Net SF
Team office	9		
Team Room	35		
Crew Storage			
Support		1,528	Net SF
Break Area			
Secure Area Briefing and Planning			
Weapons Vault and Weapons Cleaning Solvent Tank room			
PPE Training Bag			1.5 SF per mobility position
Subtotal		8,940	Net SF
25% Overhead		2,235	
Subtotal		11,174	
Functional Standard	85	11,200	Gross SF

Table 5-38: CATCODE 141-753, Air Support Ops Squad, Shops, 20 Personnel

Major Functions & Breakouts	Authorized Staffing	Target Area (SF)	Remarks
Drive-thru work bay			See Note 3
Bench Stock			
Maintenance Management	2		
Inspections	2		
Material management	4		
AGE/Power Pro/HVAC	5		
RF Transmission Sys	7		
Subtotal		3,768	Net SF
15% Overhead		565.2	
Subtotal		4,333	
Functional Standard	20	4,300	Gross SF

NOTES:

- The standard ASOS unit is also authorized 15,000 Gross SF under [CATCODE 214-428 Vehicle Operations Parking Shed](#).
- The standard ASOS unit is also authorized 2,600 Gross SF of warehouse type storage ([CATCODE 442-758, Base Supply and Equipment Warehouse](#)) for mobility / field equipment.
- One drive-thru work bay to accommodate two (2) of the largest authorized radio equipped vehicles (HMMWV's)

Table 5-39: CATCODE 141-753, Air Support Ops Squad Admin and Shop Total

Function	Functional Standard (Gross SF)
ASOS Admin / Operations / Support	11,200
ASOS Shop	4,300
ASOS Total	15,500

5.13 CATCODE 141-783, Small Air Terminal (SAT)

5.13.1 Small Air Terminals provide training, administrative, and storage space for SAT functions to include the Space Available (Space A) program management. Separate areas are required in which to store training loads and supplies, conduct administrative functions, and classroom training.

5.13.2 Those facilities that store a Modular Airborne Firefighting System (MAFFS) are authorized an additional 1,000 Gross SF of covered, unheated space.

5.13.3 Small Air Terminal, KC-135, 28 Personnel

Table 5-40: CATCODE 141-783, Small Air Terminal KC-135, 28 Personnel

Major Functions & Breakouts	Authorized Staffing	Target Area (SF)	Remarks
Administration	28	2,281	Net SF
Air Transportation Superintendent	1		
Training & Testing			See Chapter 1
Conference & Meeting			See Chapter 1
Air Transportation Superintendent	1		
T.O. Library			
Load Planning	3		
Unit Material Handling Equipment (MHE) Operators / Unit Move Operations	7		Operate material handling equipment or stand-by. Sized for 10 personnel @ 10 SF per person
Ramp / Cargo Services	4		Sized for 3 work stations at 64 SF per person and 3 Hoteling stations at 24 SF per person. Room will stage flight line personnel and associated admin functions.
Air Transportation Operations Center (ATOC) NCOIC	3		Dispatch and Crew Brief Area
Passenger Services	4		Staging area for baggage processing personnel and 16 potential Space "A" passengers.
Joint Inspection	3		Work primarily outside but require admin space to perform daily office work.
Documentation Quality Control	1		
Hazardous Cargo Compatibility & Validation	1		
PPE Training Bag Storage			
Support	0	2,254	Net SF
Fleet Non-Expendables, Expendables & Comfort Items Storage			Sixty day storage of expendable items such as earplugs, air sickness bags, and hot cups; also storage of non-expendables and comfort items such as: hundreds of pillows and blankets, and ice machine, and 16 - 5 gallon igloos.
JI Equipment Storage			Storage for kits, scales, and laptops. At least two portable scales in containers sized about 9 cubic feet.

Major Functions & Breakouts	Authorized Staffing	Target Area (SF)	Remarks
Pallet Build-up & Storage Area			Covered space for four “463L Pallets” (88" x 108"). Twelve feet high access for 10K forklift. See Note 1.
Security Cage			Security required cargo
Subtotal		4,535	Net SF
25% Overhead		1,134	See Note 3
Subtotal		5,669	
Functional Standard		5,700	Gross SF

- 1 NOTES:
- 2 1. Before authorizing the pallet build up and storage area, the installation must consider other underutilized spaces
- 3 ([CATCODE 442-758, Base Supply and Equipment Warehouse](#), others) and coordinate with NGB/A4FD.
- 4 2. If the facility is collocated with another function, change the overhead factor to 10% and recalculate.
- 5
- 6

5.13.4 Small Air Terminal, KC-46, 32 Personnel.

Table 5-41: CATCODE 141-783, Small Air Terminal KC-46, 32 Personnel

Major Functions & Breakouts	Authorized Staffing	Target Area (SF)	Remarks
Administration	32	2,281	Net SF
Air Transportation Chief	1		
Air Transportation Superintendent	1		
Training & Testing			See Chapter 1
Conference & Meeting			See Chapter 1
T.O. Library			
Load Planning	2		
Fleet Services	6		Hoteling space @ 24 SF per person
Unit Material Handling Equipment (MHE) Operators / Unit Move Operations	6		Operate material handling equipment or stand-by. Sized for 10 personnel @ 10 SF per person
Ramp / Cargo Services	4		Sized for 2 workstations at 64 SF/PP and 2 hoteling type stations at 24 SF/PP. Room will stage flight line personnel and associated admin functions.
Air Transportation Operations Center (ATOC) NCOIC	2		Dispatch and Crew Brief Area
Passenger Services	4		Staging area for baggage processing personnel and 16 potential Space "A" passengers @ 18 SF/PP.
Joint Inspection	3		Work primarily outside but require admin space to perform daily office work.
QA	1		
Documentation Quality Control	1		
Hazardous Cargo Compatibility & Validation	1		
PPE Training Bag Storage			
Support	0	2,254	Net SF
Fleet Non-Expendables, Expendables & Comfort Items Storage			Sixty day storage of expendable items such as earplugs, air sickness bags, and hot cups; also storage of non-expendables and comfort items such as: hundreds of pillows and blankets, and ice machine, and 16 - 5 gallon igloos.
JI Equipment Storage			Storage for kits, scales, and laptops. At least two portable scales in containers sized about 9 cubic feet.
Pallet Build-up & Mx			Pallet build with scale and access to sewer for Air Transportable Galley Lavatory (ATGL), see Note 1
Aerial Delivery Storage Area			For 20 Seat Pallets, 9 Patient Support Pallets, and 4 ATGLs with circulation, one story on rollers, see Note 1
Security Cage			Security required cargo
Subtotal		9,947	Net SF
25% Overhead		2,487	See Note 3
Subtotal		12,434	
Functional Standard	32	12,400	Gross SF

NOTES:

- Before authorizing the pallet build up and storage area, the installation must consider other underutilized spaces ([CATCODE 442-758, Base Supply and Equipment Warehouse](#), others) and coordinate with NGB/A4FD.
- If the facility is collocated with another function, change the overhead factor to 10% and recalculate.

5.13.5 Small Air Terminal, C-17, 46 Personnel

Table 5-42: CATCODE 141-783, Small Air Terminal C-17, 46 Personnel

Major Functions & Breakouts	Authorized Staffing	Target Area (SF)	Remarks
Administration	46	2,990	Net SF
Air Transportation Manager	1		
Air Trans Superintendent	1		
Training & Testing			See Chapter 1
Conference & Meeting			See Chapter 1
T.O. Library			
Load Planning	4		
Unit Material Handling Equipment (MHE) Operators / Unit Move Operations	12		Operate materials handling equipment or stand-by. Sized for 12 personnel
Ramp / Cargo Services	8		Sized for 3 workstations and 3 Hoteling stations. Room will stage flight line personnel and associated admin functions.
Air Transportation Operations Center (ATOC) NCOIC	6		Dispatch and Crew Brief Area
Break Area / Passenger Services Processing / Holding Area	9		Staging area for baggage processing personnel and 16 potential Space "A" passengers.
Joint Inspection	3		Work primarily outside but require admin space to perform daily office work.
Documentation Quality Control	1		
Hazardous Cargo Compatibility & Validation	1		
PPE Training Bag Storage			
Support	0	7,415	Net SF
Fleet Non-Expendables, Expendables & Comfort Items Storage			Sixty day storage of expendables (earplugs, air sickness bags, and hot cups), and non-expendables (hundreds of pillows & blankets, ice machine, and 16 - 5 gallon igloos.)
Parachute Drying Tower			See Note 2
Parachute Laundry & Repair			See Note 2
Parachute Packing			See Note 2
J1 Equipment Storage			Storage for kits, scales, and laptops. At least two portable scales in containers sized about 9 cubic feet.
Pallet Build-up & Storage Area			Covered space for four "463L Pallets" (88" x 108"). Twelve feet high access for 10K forklift.
Aerial Delivery Prep & Storage Area			Covered space for 16 Load Bearing Platforms (96" x 108") and 24 Containerized Delivery Systems(48" x 48")
Secure Area			Security required cargo
Subtotal		10,405	Net SF
25% Overhead		2,601	
Subtotal		13,006	
Functional Standard		13,000	Gross SF

NOTES:

- Before authorizing the pallet build up and storage area, the installation must consider other underutilized spaces ([CATCODE 442-758 - Base Supply Warehouse](#), others) and coordinate with NGB/A4FD.
- If the facility is collocated with another function, change the overhead factor to 10% and recalculate.

5.13.6 Small Air Terminal, C-130, 48 Personnel

Table 5-43: CATCODE 141-783, Small Air Terminal C-130, 48 Personnel

Major Functions & Breakouts	Authorized Staffing	Target Area (SF)	Remarks
Administration	48	3,181	Net SF
Air Transportation Manager	1		
Air Transportation Superintendent	1		
Training & Testing			See Chapter 1
Conference & Meeting			See Chapter 1
T.O. Library			
Load Planning	6		
Unit Material Handling Equipment (MHE) Operators / Unit Move Operations	12		Operate material handling equipment or stand-by. Sized for 12 personnel
Ramp / Cargo Services	8		Sized for 3 workstations and 5 Hoteling stations. Room will stage flight line personnel and associated admin.
Air Transportation Operations Center (ATOC) NCOIC	6		Dispatch and Crew Brief Area
Break Area / Passenger Services Processing / Holding Area	9		Staging area for baggage processing personnel and 16 potential Space "A" passengers
Joint Inspection	3		Work primarily outside but require admin space to perform daily office work.
Documentation Quality Control	1		
Hazardous Cargo Compatibility & Validation	1		
PPE Training Bag Storage			
Support	0	7,415	Net SF
Fleet Expendables, Non-Expendables, & Comfort Items Storage			Sixty day storage of expendables (earplugs, air sickness bags, and hot cups), and non-expendables (hundreds of pillows & blankets, ice machine, and 16 - 5 gallon igloos.)
Parachute Drying Tower			
Parachute Laundry & Repair			
Parachute Packing			
JI Equipment Storage			Storage for kits, scales, and laptops. At least two portable scales in containers sized about 9 cubic feet.
Pallet Build-up & Storage Area			Covered space for four "463L Pallets" (88" x 108"). Twelve feet high access for 10K forklift.
Aerial Delivery Prep & Storage Area			Covered space for 16 Load Bearing Platforms (96" x 108") and 24 Containerized Delivery Systems(48" x 48")
Secure Area			Security required cargo
Subtotal		10,596	Net SF
25% Overhead		2,649	
Subtotal		13,245	
Functional Standard		13,200	Gross SF

NOTES:

- Before authorizing the pallet build up and storage area, the installation must consider other underutilized spaces ([CATCODE 442-758, Base Supply and Equipment Warehouse](#), others) and coordinate with NGB/A4FD.
- If the facility is collocated with another function, change the overhead factor to 10% and recalculate.

5.13.7 Small Air Terminal, HC-130, 24 Personnel

Table 5-44: CATCODE 141-783, Small Air Terminal HC-130, 24 Personnel

Major Functions & Breakouts	Authorized Staffing	Target Area (SF)	Remarks
Administration	24	1,986	Net SF
Air Transportation Superintendent	1		
Training & Testing			See Chapter 1
Conference & Meeting			See Chapter 1
T.O. Library			
Load Planning	3		
Unit Material Handling Equipment (MHE) Operators / Unit Move Operations	6		Operate material handling equipment or stand-by. Sized for 7 personnel
Ramp / Cargo Services	2		Sized for 2 workstations and 2 hoteling type stations. Room will stage flight line personnel and associated admin
Air Transportation Operations Center (ATOC) NCOIC	3		Dispatch and Crew Brief Area
Passenger Services	4		Staging area for baggage processing personnel and 16 potential Space "A" passengers
Joint Inspection	3		Work primarily outside but require admin space to perform daily office work.
Documentation Quality Control	1		
Hazardous Cargo Compatibility & Validation	1		
PPE Training Bag Storage			
Support	0	6,135	Net SF
Fleet Non-Expendables, Expendables & Comfort Items Storage			Sixty day storage of expendables (earplugs, air sickness bags, and hot cups), and non-expendables (hundreds of pillows & blankets, ice machine, and 16 - 5 gallon igloos)
Parachute Drying Tower			
Parachute Laundry & Repair			
Parachute Packing			
JI Equipment Storage			Storage for kits, scales, and laptops. At least two portable scales in containers sized about 9 cubic feet.
Pallet Build-up & Storage Area			Covered space for four "463L Pallets" (88" x 108"). Twelve feet high access for 10K forklift.
Aerial Delivery Prep & Storage Area			Covered space for 16 Load Bearing Platforms (96" x 108") and 24 Containerized Delivery Systems(48" x 48")
Secure Area			Security required cargo
Subtotal		8,121	Net SF
25% Overhead		2,030	
Subtotal		10,151	
Functional Standard		10,200	Gross SF

NOTES:

- Before authorizing the pallet build up and storage area, the installation must consider other underutilized spaces ([CATCODE 442-758, Base Supply and Equipment Warehouse](#), others) and coordinate with NGB/A4FD.
- If the facility is collocated with another function, change the overhead factor to 10% and recalculate.

5.14 CATCODE 141-786, Deployment Processing Center

- 5.14.1 The deployment processing center provides space for receiving and processing personnel and baggage; baggage pallet buildup; counseling; passenger (PAX) processing, briefing, and holding; miscellaneous space such as rest rooms; and a vending area. Space is also required for both a Cargo Deployment Function (CDF) and a Personnel Deployment Function (PDF), to include a Deployment Control Center (DCC), Transportation Control Unit (TCU), and a Deployment Processing Unit (DPU).
- 5.14.2 A deployment processing center is authorized at any installation charged with deploying personnel and equipment. When located on another DoD installation with a deployment processing facility, ANG units will use the host facilities unless justified to NGB/A4F.
- 5.14.3 Table 5-44 depicts the Functional Standard for a Deployment Processing Center at an installation that does not have a Small Air Terminal, [CATCODE 141-783, Small Air Terminal \(SAT\)](#).

Table 5-45: CATCODE 141-786, Deployment Processing Center, No SAT

Major Functions & Breakouts	Authorized Staffing	Target Area (SF)	Remarks
Passenger Reception			
Passenger Processing			
Passenger Holding			Sanitized area, limited access
Installation Readiness / Plans Officer	1		
Contingency Plans & Training NCOIC	1		
Contingency Plans & Training Technicians	2		
DCC Control Cab			
Small Air Terminal Operations	2		
Passenger Deployment Function			
Cargo Deployment Function			
Cargo Processing Area			
Counseling Rooms			
Briefing / Break Area			
Subtotal		6,320	Net SF
25% Overhead		1,580	
Subtotal		7,900	
Functional Standard		7,900	Gross SF

1 5.14.4 An installation with a Small Air Terminal, [CATCODE 141-783, Small Air Terminal \(SAT\)](#),
 2 will have a collocated and reduced scope Deployment Processing Center. Table 5-45
 3 depicts the Functional Standard for a Deployment Processing Center at an installation that
 4 also has an SAT.

5 **Table 5-46: CATCODE 141-786, Deployment Processing Center, Collocated with SAT**

Major Functions & Breakouts	Authorized Staffing	Target Area (SF)	Remarks
Passenger Reception			
Passenger Processing			
Passenger Holding			Sanitized area, limited access
DCC Control Cab			
Passenger Deployment Function			
Cargo Deployment Function			
Subtotal		2,420	Net SF
10% Overhead		242	
Subtotal		2,662	
Functional Standard		2,700	Gross SF

6
 7

5.15 CATCODE 145-921, Overhead Protection

This function is a self-supported permanent structure that is not connected to the gatehouse or Gatehouse roof system and provides cover and protection from the elements for personnel checking identification at the main gates of installations and other locations. One inbound lane will be covered at **600 Gross SF** total for ID Check at the gatehouse (POVs the clear height must be 15 feet per UFC 4-022-01). The use of a privacy screen fence for commercial vehicle inspection is preferred if visibility of inspections is needed, see [Figure 11-8](#). An authorization for commercial vehicle inspection overhead protection of 1,200 SF, (20'x60' typical), can be granted by exception with NGB/A4F approval. Commercial Vehicle Inspection overhead protection minimum desirable clear height must be 17.5 feet per UFC 4-022-01.

Figure 5-2: Use CATCODE 145-921, Overhead Protection, only when not connected to the Gatehouse

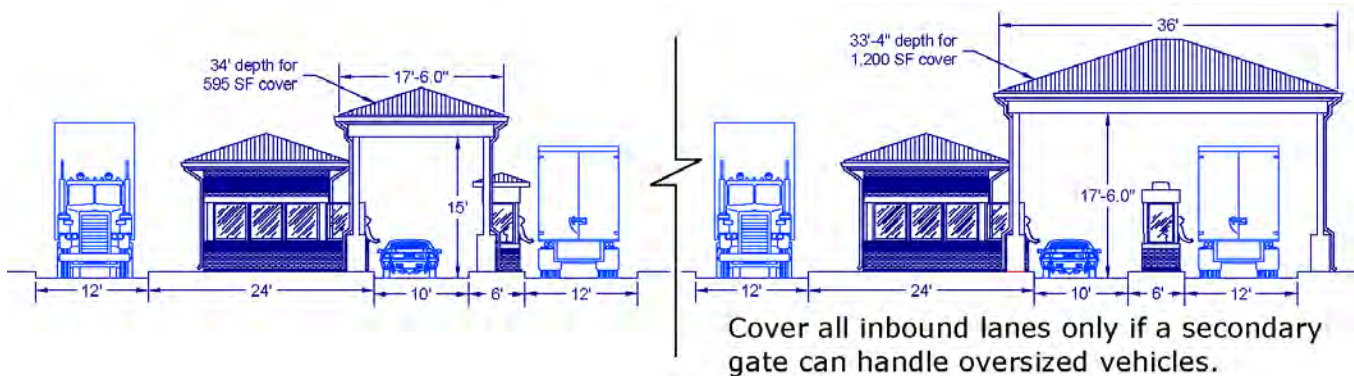

5.16 CATCODE 149-511, RPA Support Operations Center (SOC)

- 5.16.1 SOC consists of the Remote Piloted Aircraft (RPA) and Ground Control Stations (GCS's).
- 5.16.2 The following function is based on the operations manpower requirements determined for a Combat Air Patrol (CAP) MQ-1 / MQ-9 (one steady-state, two surge).
- 5.16.3 SOC manning is based on multiple shifts of 72 personnel each.

Table 5-47: CATCODE 149-511, RPA Support Ops Center, 72 Personnel per Shift

Major Functions & Breakouts	Authorized Staffing	Target Area (SF)	Remarks
Command & Administration	3	3,990	Net SF
Shift OIC	1		
Shift Director of Operations	1		
Shift NCOIC	1		
Conference & Meeting			See Chapter 1
Training & Testing			See Chapter 1
Intel Secure Admin Office			4 (up to 6) work stations
Crew In / Out Briefing Room			45 person
Classified VTC / PMATS			
Pilot / Sensor Operator			
Classified Intel Briefing			
Mission Planning			
Storage			
SSO Office / Entrapment Area			
Direct Operations Space	23	4,410	Net SF
RPA Operations Center Floor			
Server Room			
Server Room Contractor Support Office			
Fixed Ground Control Station (GCS) 1			
Fixed GCS 2			
Mobile GCS Bay			
Support	0	200	Net SF
Secure Area Unisex Bathroom			
Break Area			
Subtotal		8,600	Net SF
25% Overhead		2,150	
Subtotal		10,750	
Functional Standard		10,800	Gross SF (See Note 6)

NOTES:

1. RPA Operations is an around the clock operation consisting of three 8 hour shifts. Only three personnel permanently assigned to this facility; the remaining 69 personnel are broken down in three shifts of 23 personnel each.
2. RPA Operations requires several support items. One of these is the RPA Operations Cell (POC). The Operations Centers (POC / ROC) must be Secure Space for both IOC and FOC. The unit can be mobile and facility items include equipment mounting pad, utilities, communication links, LAN (RPA mission distribution system), Joint Worldwide Intelligence Communication Systems (JWICS), Secure Internet Protocol Router (SIPR), and Non-secure Internet Protocol Router (NIPR).

- 1 3. Another support item includes the Ground Control Stations (GCS's) which can be fixed or mobile. Facilities for
2 the GCS support must assume that at least one of the GCS's will be mobile. The facility items include equipment
3 mounting pad, utilities, and communication links to MAJCOM and Combatant Commander (COCOM). The
4 RPA Primary Satellite Link (PPSL) is an equipment item that enables Beyond Line-of-Sight (BLOS) operations
5 from home station. The unit is mobile and facility items include equipment mounting pad, utilities, and
6 communication links.
- 7 4. Each area requires card reader controlled access.
- 8 5. If the SOC is collocated with [CATCODE 141-753, Squadron Operations, RPA](#) then the overhead factor will be
9 reduced to 10% and the authorized Gross SF will be 9,500 SF.
- 10

5.18 CATCODE 149-962, Air Traffic Control (ATC) Tower

5.18.1 Air Traffic Control Towers direct flight operations safety during aircraft taxi, takeoff, approach, and landing.

5.18.2 ANG locations with a flying mission have a requirement for a control tower for flight operations safety. At commercial airports, the facility should be provided by the FAA or ANG depending on the FAA eligibility or agreements. Where ANG is a tenant on another DoD installation, the host is responsible for providing Air Traffic Control Tower facilities. NGB/A4F provides approval for ATC facilities at airfields operated by the ANG.

5.18.2.1 ANG Spatial Requirements: Space requirements depend primarily on the height requirements (number of level below the cab) that are generally dictated by the site survey and statement of intent (SOI) that define some site-specific design parameters. Levels could be as little as the stairwell and elevator with the ground level for mechanical/electrical and maybe a level or two that are directly below the cab for spaces incidental to the tower operation. The descriptive level by level layout of the *Air Traffic Control Tower (ATCT) and Radar Approach Control (RAPCON) Design Guide* will not be followed for new construction.

5.18.2.2 Special Features: Consult IBC 412.1 Airport traffic control towers and the *Air Traffic Control Tower (ATCT) and Radar Approach Control (RAPCON) Design Guide* for features only. Among the considerations are panels for the remote control of airfield lighting (FAA AC-1501/153345-3C); bright radar indicator tower equipment (BRITE) terminals; instrument consoles; a light gun; communication and flight tracking consoles; special heating, ventilation, and air conditioning needs; electrical power and grounding requirements to include a back-up generator; and fire detection and suppression systems / capabilities. The FAA will approve siting of ATC towers at commercial airports.

5.18.2.3 Count full scope for the stairwell and elevator per level and the control tower cab square footage. The published 6,700 SF is sufficient, provided the tower cab is located on the 9th level. However, if the installation requires the cab to be on the 11th level, the square footage will need to be recalculated. Coordinate for NGB/A4F approval based on number of levels.

5.18.2.4 [CATCODE 179-481, Aircraft Range](#) is also authorized 225 Gross SF for “ATC Tower” and an additional 225 SF Gross SF for a radio equipment room if required.

5.19 CATCODE 149-967, Observation Tower

Each air-to-ground range requires an observation tower, UOM is EA, typical 80 Gross SF platform and are usually at least 20 meters (65.6 ft) tall with 360-degree range of vision per AF description. See [CATCODE 179-481, Aircraft Range](#).

Chapter 6: Category Group 17 – Training Facilities

6.1 General Criteria

ANG training facilities encompass those needed to support marching / concert bands, flight simulators, communications and electronics training, aeromedical evacuation and medical training, combat arms training and maintenance, small arms ranges, and aircraft ranges, as well as the command structures necessary for their operation.

6.2 CATCODE 171-211, Flying Training Classroom

The facility provides classrooms required by flying training programs listed in AFCAT 36-2223. These classrooms identified under this code are separate from and augment

1 [CATCODE 141-753](#), Squadron Operations (Sqd Ops), and CATCODE 171-212, Simulator
2 Training.

3

6.3 CATCODE 171-212, Simulator Training

- 6.3.1 Simulator training functions provide aircraft flight simulators and other special training devices such as Air Combat Maneuvering and Instrumentation (ACMI), Aircrew Combat Training System (ACTS), Boom Operator System Simulators (BOSS), Predator Mission Aircrew Training System (PMATS), Full Immersion Simulators for fighters and Remotely Piloted Aircraft (RPAs), Air Support Operations Squadron Crew (ASOS-Crew), and others. The functions may include space for administration and records, classrooms, trainer maintenance, supply storage, counseling space, a technical library, and simulator computer server space, secure storage space.
- 6.3.2 The scope and authorization of this function will be determined by NGB/A4F, based on mission, equipment, and staffing assigned. Where possible, the space should be collocated with Squadron Operations or other functions as required.
- 6.3.3 Consult the weapon system specifications to determine appropriate ceiling height to accommodate simulator equipment
- 6.3.4 Flight simulators should be collocated with the Squad Ops for each respective mission if space is available in order to share classroom space. ([CATCODE 141-753, Squadron Operations \(Sqd Ops\)](#)).

Table 6-1: CATCODE 171-212, Sim Training Summary by Aircraft / Mission

Mission	Functional Standard (Gross SF)	Remarks
A-10, F-15, F-16 Flight Simulator	1,500	2-Ship Full Mission Trainer (FMT). See Note 1.
	2,300	4-Ship FMT. See Note 1.
F-15EX	2,500	4-Ship, stationary sim with backseater spot
F-16 Mission Training Center (MTC)	9,200	4 Mission Simulators, see following table for details
	6,700	2 Mission Simulators, see following table for details
F-35 Flight Simulator	20,000	4-Ship Full Mission Simulator (FMS), includes all support space. See Note 1.
KC-46A Boom Operator Trainer (BOT)	1,100	Full Motion BOT and is collocated with the KC-46A WST
KC-46A Weapon System Trainer (WST)	5,100	Stand-alone facility will be 5,800 Gross SF, this is the Full Motion KC-46 Flight Simulator with supporting systems
KC-46 Fuselage Trainer (FuT)	10,075	KC-46 Fuselage section inside a building for cargo load training, aeromedical evacuation training, and other simulated training. Includes 2,600 SF of covered storage per AF Typical.
ASOS Crew Trainer	1,000	Full Immersion Simulator
KC-135 Flight Simulator	5,900	Stand alone facility for Full Motion KC-135 Simulator
Boom Operator Simulator System (BOSS)	900	Non-COMS sites. COMS (Contractor Operator Maintainer Support) sites are authorized an additional 200 SF. COMS sites have more spare parts inventory than non-COMS sites. The BOSS is a smaller footprint KC-135 Boom Sim.
Boom Operator Weapon System Trainer (BOWST)	1,200	The BOWST is a larger KC-135 Boom Sim
C-17 Flight Simulator	11,500	Full Motion Simulator
C-130 Flight Simulator	8,300	Full Motion Simulator
C-130J Flight Simulator	10,600	Full Motion Simulator

Combat Readiness Training Center (CRTC)	14,000	ACMI / ACTS
Predator Mission Aircrew Training System (PMATS) – single simulator	1,300	See Note 3
Predator Mission Aircrew Training System (PMATS) – dual simulator	1,800	See Note 3
Combat Arms Training Simulator (CATS)	1,200	See Notes 2
Security Forces Engagement Skills Trainer with 180° WST Configuration	3,700	Located at CRTC's
Security Forces Engagement Skills Trainer with 360° WST Configuration	5,100	Located at CRTC's
Special Tactics Squadron Simulators	3,000	ATC Sim, FATS, Medical, JTC-TRS, IFACT / DTCO / DMO, Parachute Emergency Procedures

- 1 NOTES:
- 2 1. F-15/F-16/F-35 Flight Simulators must be located in a classified area.
- 3 2. Not intended as stand-alone facility, designed for 8 firing positions and has defined HVAC, lighting and
- 4 electrical requirements.
- 5 3. PMATS are used for either MQ-1 or MQ-9
- 6

1

Table 6-2: CATCODE 171-212, Simulator Training, F-16 MTC, 4 Mission Simulators

Major Functions & Breakouts	Authorized Staffing	Target Area (SF)	Remarks
Simulator Room		4,050	Net SF, 4 Mission Simulators
Support	7	3,298	Net SF
Sim Manager			
Security Manager			
Instructor operator station (IOS)			
Instructors Workstations			
Brief/Debrief Station (BDS)			
Mission Observer Center (MOC)			
Network			
UPS			
Scenario Generation Station (SGS)			
Maintenance work area and desks			
Maintenance Workstations			
Spare Storage			
Subtotal		7,348	Net SF
10% Overhead		1,837	
Subtotal		9,185	
Functional Standard		9,200	Gross SF

2

Table 6-3: CATCODE 171-212, Simulator Training, F-16 MTC, 2 Mission Simulators

Major Functions & Breakouts	Authorized Staffing	Target Area (SF)	Remarks
Simulator Room		2,025	Net SF, 2 Mission Simulators
Support	7	3,298	Net SF
Sim Manager			
Security Manager			
Instructor operator station (IOS)			
Instructors Workstations			
Brief/Debrief Station (BDS)			
Mission Observer Center (MOC)			
Network			
UPS			
Scenario Generation Station (SGS)			
Maintenance work area and desks			
Maintenance Workstations			
Spare Storage			
Subtotal		5,323	Net SF
10% Overhead		1,331	
Subtotal		6,654	
Functional Standard		6,700	Gross SF

3

4

6.4 CATCODE 171-443, Reserve Forces General Training Support

6.4.1 This function supports various ANG mission support units not otherwise defined, including – but not limited to – honor guard flights, services flights, weather flights, Contingency Response Flight (CRF), etc., and encompasses office and administrative areas, administrative support space, classrooms, and storage space.

6.4.2 Specific space requirements for different sized units or other requirements unique to a particular unit will be separately determined.

6.4.3 Honor Guard Flight – 30 Personnel.

Table 6-4: CATCODE 171-443, Honor Guard Flight - 30 Personnel

Major Functions & Breakouts	Authorized Staffing	Target Area (SF)	Remarks
Command & Administration	2	854	Net SF
Flight Chief	1		
Flight NCOIC	1		
Conference & Meeting Space			See Chapter 1
Honor Guard Coordination Center			
Training & Support	28	1,480	Net SF
Drill & Training Area			
Individual Equipment Lockers			
Unit Equipment Lockers			6 Units (Flags, banners, supplies, etc.)
Clothes Racks			4 Units
Weapons Storage Cabinet			15 Weapons (Max.)
Practice Casket Storage			1 Unit (3' x 8') with access space
Subtotal		2,334	Net SF
10% Overhead		233	
Subtotal		2,567	
Functional Standard		2,600	Gross SF

NOTE:

1. This function is intended to be collocated with another function.

6.4.4 Sustainment Services Flight, 20 / 30 / 41 / 51 Personnel

Table 6-5: CATCODE 171-443, Services Flight - 20 / 30 / 41 / 51 Personnel

Major Functions & Breakouts	Authorized Staffing by Category				Target Area (SF) by Category				Remarks
	I	II	III	IV	I	II	III	IV	
Command & Administration	20	30	41	51	1,326	1,887	2,472	3,171	Net SF
Flight Commander / Officer	1	1	1	2					
Training & Testing									See Chapter 1
Conference & Meeting Space									See Chapter 1
Services NCOIC	1	1	2						
Superintendent			1	1					
Protocol Officer				1					Located @Wing O&T
Resource Manager - NAF		1	1	1					
Mortuary Affairs Superintendent				1					
Mortuary Affairs Supervisor				2					
Mortuary Affairs Specialist				5					
Mortuary Affairs Apprentice				2					
Food Services Superintendent	1	1	2	2					
Food Services Supervisor	3	5	6	6					
Food Services Specialist	2	3	4	4					Work in Dining Hall
Food Services Apprentice	4	7	8	8					Work in Dining Hall
Transient Lodging Supervisor	1	1	2	2					
Transient Lodging Specialist	2	3	4	4					Work elsewhere
Fitness Supervisor	1	1	2	2					
Fitness Specialist	1	2	2	2					Work in Fitness Center
Recreation Supervisor	1	1	2	2					
Recreation Specialist	2	3	4	4					
T.O. / Library									
PPE Training Bag Storage									
Support (applicable to all SSF's)	0	0	0	0	2,570	2,570	2,570	2,570	Net SF
Home Station Training (HST) Storage									
UTC Team Kit Storage									
Single Pallet Expeditionary Kitchen (SPEK) Storage									One 463L pallet built-up and access area
Subtotal					3,896	4,457	5,042	5,741	Net SF
25% Overhead					974	1,114	1,260	1,435	
Subtotal					4,870	5,571	6,302	7,176	
Functional Standard					4,900	5,600	6,300	7,200	Gross SF

6.4.5 Combat Weather Flight (Battlefield), 15 Personnel

Table 6-6: CATCODE 171-443, Combat Weather Flight, 15 Personnel

Major Functions & Breakouts	Authorized Staffing	Target Area (SF)	Remarks
Command & Administration	15	1,524	Net SF
Commander	1		
Weather Superintendent	1		
Meteorological Technician	1		
Training & Testing			See Chapter 1
Conference & Meeting			See Chapter 1
Unit Deployment Manager Storage			
Weather Element	12		
Support	0	639	Net SF
T.O. Library			
Break Area			
Media Center			
SIPRNET Room			
Weapons Safe & Cleaning			
NVG Storage			
PPE Training Bag Storage			
Subtotal		2,163	Net SF
10% Overhead		216	
Subtotal		2,379	
Functional Standard		2,400	Gross SF

NOTES:

- This function is intended to be collocated with another base function. If not feasible, then apply the stand-alone facility overhead factor (25%) and recalculate the functional standard.
- The following additional functional standards are also part of the Combat Weather Flight mission set:
 - [CATCODE 442-758, Base Supply & Equipment Warehouse](#) – IAW Table 9-3 (3,700 Gross SF)
 - [CATCODE 852-263, Vehicle Parking \(Unsurfaced\)](#) – 200 SY (this area can also be used as an outdoor area to set up TMQ-53 and BGAN training equipment)

6.4.6 Special Operations Weather Team (SOWT), 18 Personnel

Table 6-7: CATCODE 171-443, Special Operations Weather Team, 18 Personnel

Training	Authorized Staffing	Target Area (SF)	Remarks
Command & Administration	5	828	Net SF
Commander	1		
Training & Testing			See Chapter 1
Conference & Meeting			See Chapter 1
Staff Weather Officer	3		
Administration	1		Includes UDM storage
Operations & Training	13	988	Net SF
Superintendent	1		
T.O. Library			
Meteorological Technician	1		
Weather Forecaster	11		
Support	0	1,699	Net SF
Break Area			
Media Center			
SIPRNET Room			
NVG Storage			
Parachute Maintenance / Storage			
Laundry			
Weapons Safe / Cleaning			
Secure Radio Storage			
PPE Training Bag Storage			
Subtotal		3,515	Net SF
10% Overhead		352	
Subtotal		3,867	
Functional Standard		3,900	Gross SF

NOTES:

3. This function is intended to be collocated with another base function. If not feasible, then apply the stand-alone facility overhead factor (25%) and recalculate the functional standard.
4. The following additional functional standards are also part of the SOWT mission set:
 - [CATCODE 442-628, Base Supply & Equipment Shed](#) – IAW Table 9-2 (1,100 Gross SF)
 - [CATCODE 442-758, Base Supply & Equipment Warehouse](#) – IAW Table 9-3 (3,600 Gross SF)
 - [CATCODE 740-674, Physical Fitness](#) (includes surface swim area) – Apply the GSU standard (700 Gross SF) if unit is a GSU (Table 12-1), if not a GSU, add 330 Gross SF to the installation’s Physical Fitness requirement.
 - [CATCODE 852-263, Vehicle Parking \(Unsurfaced\)](#) – 200 SY

6.4.7 Contingency Response Flight, 31 Personnel

Table 6-8: CATCODE 171-443, Contingency Response Flight, 31 Personnel

Major Functions & Breakouts	Authorized Staffing	Target Area (SF)	Remarks
Command & Administration	2	954	Net SF
Commander	1		
Training & Testing			See Chapter 1
Conference & Meeting			See Chapter 1
Administration	1		
T.O. Library			
Operations & Training	29	2266	Net SF
Operations Officer	1		
Air Trans	1		
Air Trans	2		
Air Trans	4		
Mssn Gen Veh Equip	1		
Aircrew Loadmaster	1		
Aircrew Loadmaster	1		
Air Traffic Control	2		
Cmd & Control Op	1		
Airfield Management	2		
Cyber Defense Ops	2		
Aircraft Mx	1		
AGE Technician	1		
Mobility AF Intg Com	1		
Elec Pwr Production	1		
Engineering	1		
Security Forces	5		
Weather Forecaster	1		
Support	0	1952	Net SF
Break Area			
PPE Training Bag Storage			1.5 SF/Mobility Position
LOGDET Equipment			UTC 7E1A1
LOGDET Equipment			UTC 7E1SF
Pallet Build-up Area			Two - 463L Pallets
Built-up Pallet Storage			Four 463L Pallets, size door for 10k forklift entry
Subtotal		5,172	Net SF
25% Overhead		1,293	
Subtotal		6,464	
Functional Standard		6,500	Gross SF

Note:

The following additional functional standards are also part of the Contingency Response Flight mission set:

1. CATCODE 852-261, Vehicle Parking Ops - 340 SY
2. Contingency Response Flight, 31 Personnel replaced the Airlift Control Flight (ALCF) / Tactical Airlift Control Element (TALCE), 50 Personnel

1 6.4.8 F-15 Enhanced Eagle Test Center (EETC), 7 Personnel

2 **Table 6-9: CATCODE 171-443, F-15 Enhanced Eagle Test Center (EETC), 7 Personnel**

Major Functions & Breakouts	Authorized Staffing	Target Area (SF)	Remarks
Command & Administration	7	654	Net SF
Testing Staff	2		
Testing Room	5		
Maintenance Bay			
Subtotal		654	Net SF
25% Overhead		164	
Subtotal		818	
Functional Standard		800	Gross SF

3
 4
 5

6.5 CATCODE 171-445, Reserve Forces Operational Training

- 6.5.1 Designated as common for ANG units; includes space for the Wing (wing commander and staff, EO, Chaplain, JA, public affairs, and safety), the Comptroller Flight, the MSG, and FSS minus Services (OSC of FSV*) and Readiness and Plans (OSC of FSO*). Logistics Readiness / Plans space now included in the [CATCODE 141-786, Deployment Processing Center](#).
- 6.5.2 For Combat Readiness Training Center (CRTC), visiting unit space is used primarily as in the war fighting environment (IC2, EOC, etc.)
- 6.5.3 For RED HORSE (Rapid Engineer Deployable Heavy Operational Repair Squadron, Engineering) applications, this facility provides primary space for squadron administration in support of the unit; includes space for the commander, first sergeant, and mission support.

Table 6-10: CATCODE 171-445, Reserve Forces O & T, Flying Unit, 90 Personnel

Major Functions & Breakouts	Authorized Staffing	Target Area (SF)	Remarks
Wing Staff	9	2,066	Net SF
Wing Commander	1		
Vice Commander	1		
Executive Support	1		
Director of Staff	1		
Inspector General	1		
Command Chief Master Sergeant	1		
First Sergeant	1		
Human Resource Advisor	1		
Commander Support Staff	1		
Conference & Meeting			
Training & Testing			
Mission Support Group	10	848	Net SF
Commander	1		
Admin Officer	1		
First Sergeant	1		
Contracting Superintendent	1		
Contracting Specialists	3		
Administrative/Support Staff	3		
Financial Management	17	1,356	Net SF
Financial Management Officer	1		
Budget Officer	1		
Budget Analyst	1		
Financial Supervisor	1		
Quality Assurance	1		
Accounting	6		
Pay	6		
Storage & Equipment			
Force Support Squadron	23	2,458	Net SF
Commander	1		
Operations Officer	1		
Superintendent	1		
Administration/Personnel	2		
Flight OIC	1		
NCOIC	1		
Recruiting Supervisor	1		
Recruiters	2		
Recruiting Storage			
Retention	2		

Recruiting/Retention Waiting Area			Max 20 personnel: Share with Customer Service
Official Mail Center (OMC)			Mail receiving, scanning, sorting, securing, & distrib.
Enlistments and Separations	1		
Human Resource Systems	2		
Career Progression/Development	1		
Customer Service/ID Cards	3		
Customer Service Waiting Area			Share with Recruiting/Retention
HRO Remote Designee	1		
Education & Training NCOIC	1		
Education & Training Office	2		
SAPR	1	120	Net SF
SAPR Office	1		
Airmen & Family Readiness Flight	6	590	Net SF
AFR Program Manager	1		Civilian position
Volunteers	3		
Storage			
Yellow Ribbon Prgm Manager	1		
Yellow Ribbon Staff	1		
Chaplain	6	552	Net SF
Chaplains	3		
Administration/Personnel	3		
Equal Opportunity	3	304	Net SF
OIC	2		
NCOIC	1		
Judge Advocate	4	368	Net SF
Legal Officers	2		
Administration/Personnel	2		
Public Affairs	7	604	Net SF
OIC	1		
NCOIC	1		
Administration/Personnel	5		
Storage			
Safety	4	312	Net SF
OIC	1		
NCO	3		
Miscellaneous	0	3,840	Net SF
Multi-Purpose Training			Capacity for 250 persons
Projection/Storage			
Break Area			
PPE Training Bag Storage			1.5 SF/mobility position
Subtotal		13,418	Net SF
25% Overhead		3,355	
Subtotal		16,773	
Functional Standard	90	16,800	Gross SF

- 1 NOTE:
 2 1. Add 80 Gross SF to Wing Staff for Protocol Officer and 80 Gross SF for Protocol NCO where authorized
 3 2. Add 150 Gross SF to Wing Staff for Anti-terrorism Officer (ATO) where authorized.

6.5.4 RPA Formal Training Unit (FTU)

A unit established to provide pilot and sensor operator training for RPAs. The FTU will have space for two fully functional Mobile Ground Control Stations (MCGS) and a two dual-GCS Predator Mission Aircrew Training Systems (PMATS). The FTU will have 2 classrooms suitable to hold up to 30 students and include Brief/Debrief rooms and a mission planning area. Typical manning will be 44 military and 10 contractors. By collocating the FTU and currency training (CT) PMATS functional efficiencies can be achieved.

Table 6-11: CATCODE 171-445, RPA Formal Training Unit (FTU), 54 Personnel

Major Functions & Breakouts	Authorized Staffing	Target Area (SF)	Remarks
Command & Administration	5	938	Net SF
FTU Commander	1		
FTU Ops	1		
NCOIC	1		
Knowledge Ops	1		
Education & Training	1		
Conference & Meeting			
FTU Operations	39	7,955	Net SF
Instructor Pilots	9		
Instructor Sensor Operators	8		
Scheduling & Training	4		
Weapons & Tactics	3		
Classroom 1			Capacity for 30 students
Classroom 2			Capacity for 30 students
Mobile GCS			Capacity for 2 MCGSs
Student Study/Hotel Stations			
Brief/Debrief Rooms			
Mission Planning			
Intel OIC	1		
Weather NCOIC	1		
Intel	7		
Weather	2		
FCSS			
Contractor Support	10	632	Contractor Support
Contractor Site Lead	1		Contractor Site Lead
Contractor Instructor Pilots	3		Contractor Instructor Pilots
Contractor Sensor Operators	4		Contractor Sensor Operators
Contractor Admin	1		Contractor Admin
GCS Maintenance & PMATS Support	1		GCS Maintenance & PMATS Support
Support		1,380	Net SF
Break Area (FTU Staff)			
Equipment Issue			
Registrar / admin & student processing / waiting area			
Flight Records			
Student Lounge/Hotel Stations			Based on 80 x 24 SF x 50% - split w/Student Study
Subtotal		10,905	Net SF
25% Overhead		2,726	
Subtotal		13,631	
Functional Standard		13,600	Gross SF

NOTES:

- RPA FTU is also authorized a dual-GCS PMATS (1,800 Gross SF) under [CATCODE 171-212, Simulator Training](#).
- Total authorization for the RPA FTU is 15,400 Gross SF

6.5.5 Reserve Forces Operational Training, CRTC, 16 Assigned Personnel, 115 Visiting Personnel

Table 6-12: CATCODE 171-445, Reserve Forces O & T - CRTC

Major Functions & Breakouts	Authorized Staffing	Target Area (SF)	Remarks
Visiting Unit	115	18,220	Net SF
Installation Command & Control (IC2)	15		
Emergency Operations Center (EOC)	25		
Primary CE Unit Control Center (UCC)	8		
Alternate IC2	15		Alternate Centers should be a separate facility from Primary Centers
Alternate EOC	25		Alternate Centers should be a separate facility from Primary Centers
Alternate CE UCC	8		Alternate Centers should be a separate facility from Primary Centers
Financial Management	6		
Chaplain	2		
Logistics Readiness / Plans	5		
Safety	6		
Personnel Processing			
Exercise Evaluation Team (EET) / Inspector General (IG) Work Center			
Assembly Hall			
Classrooms			
CRTC Area	14	2,000	Net SF
Commander	1		
Admin / Personnel	3		
Chief Financial Officer	1		
Financial Assistant	2		
Pay	1		
Recruiting	2		
Base Contracting Supervisor	1		
Base Contracting Administration	2		
Document Storage			
Ground Safety	1		
Training & Testing			See Chapter 1
Conference & Meeting			See Chapter 1
Subtotal		20,200	Net SF
25% Overhead		5,000	
Subtotal		25,000	
Functional Standard		25,000	Gross SF

6.5.6 Reserve Forces Operational Training, 1/2 RED HORSE Sqd, 26 Personnel (see note 1)

Table 6-13: CATCODE 171-445, Reserve Forces O & T – 26 Prsnl, 1/2 RED HORSE Sqd

Major Functions & Breakouts	Authorized Staffing	Target Area (SF)	Remarks
Command & Administration	4	2,008	Net SF
Commander	1		
First Sergeant	1		
Administration	2		
Administration Storage			
Training & Testing			See Chapter 1
Conference & Meeting			See Chapter 1
Force Support Services	19	1,328	Net SF
Admin Officer	1		
Safety	1		
Acft Mtl Technology	1		
NCOIC Admin/Training	4		
Food Service	6		
Recruiting	2		
Admin/Personnel	3		
Fin Mgmt/Comp	1		
Logistics Readiness / Plans	3	248	Net SF
OIC	1		
Readiness Staff	1		
Plans Staff	1		
Support	0	2,400	Net SF
Multi-Purpose Training			
Break Area			
PPE Training Bag Storage			
Projection / Storage			
Subtotal		5,984	Net SF
25% Overhead		1496	
Subtotal		7,480	
Functional Standard		7,500	Gross SF* (see note 1)

NOTES:

- When the RED HORSE is not the Primary Mission as collocated with a larger ANG Primary Mission or classic associate thus assign 3,000 SF in 171-445 for 1/2 RED HORSE Sqd, 26 Personnel to colocate or integrate with the Wing O&T.
- See [1/2 RED HORSE squadron and 1/4 RED HORSE squadron ANG locations.](#)

1
2
3
4
5
6
7
8
9

6.5.7 Reserve Forces Operational Training, 1/4 RED HORSE Sqd, 17 Personnel (see note 1)

Table 6-14: CATCODE 171-445, Reserve Forces O & T – 17 Prsnl, 1/4 RED HORSE Sqd

Major Functions & Breakouts	Authorized Staffing	Target Area (SF)	Remarks
Command & Administration	3	1,334	Net SF
Commander	1		
First Sergeant	1		
Administration	1		
Administration Storage			
Training & Testing			See Chapter 1
Conference & Meeting			See Chapter 1
Force Support Services	11	760	Net SF
Admin Officer	1		
Safety	1		
Acft Mtl Technology	1		
NCOIC Admin/Training	2		
Food Service	3		
Admin/Personnel	2		
Fin Mgmt/Comp	1		
Logistics Readiness / Plans	3	248	Net SF
OIC	1		
Readiness Staff	1		
Plans Staff	1		
Support	0	1,625	Net SF
Multi-Purpose Training			
Break Area			
PPE Training Bag Storage			
Projection / Storage			
Subtotal		3,967	Net SF
25% Overhead		992	
Subtotal		4,959	
Functional Standard		5,000	Gross SF* (see note 1)

NOTES:

- When the RED HORSE is not the Primary Mission as collocated with a larger ANG Primary Mission or classic associate thus assign 2,000 SF in 171-445 for 1/4 RED HORSE Sqd, 17 Personnel to collocate or integrate with the Wing O&T.
- See [1/2 RED HORSE squadron and 1/4 RED HORSE squadron ANG locations.](#)

1
 2
 3
 4
 5
 6

6.5.8 Reserve Forces Operational Training, Regional Equipment Operations Training Site (REOTS), 15 Personnel

Table 6-15: CATCODE 171-445, Reserve Forces O & T – REOTS, 15 Personnel

Major Functions & Breakouts	Authorized Staffing	Target Area (SF)	Remarks
Command & Administration	2	564	Net SF
NCOIC Operations	1		
Training & Testing			See Chapter 1
Conference & Meeting			See Chapter 1
Information Management	1		
Cadre	13	3,123	Net SF
Pavements / Construction Equip	1		
Pavements / Construction Equip	2		
Pavements / Construction Equip	6		
Equipment Maintenance	1		
Equipment Maintenance	1		
Inventory Management	1		
Sustainment Services	1		
Training Room / Classroom / Multi-purpose Area (School)			Sized for 75 personnel
CBT Area (School)			Work stations
Break Area			
PPE Training Bag Storage			
Subtotal		3,687	Net SF
25% Overhead		922	
Subtotal		4,609	
Functional Standard		4,600	Gross SF

6.5.9 Reserve Forces Operational Training, Regional Training Site (RTS), 12 Personnel

Table 6-16: CATCODE 171-445, Reserve Forces O & T – RTS, 12 Personnel

Major Functions & Breakouts	Authorized Staffing	Target Area (SF)	Remarks
Command & Administration	1	444	Net SF
NCOIC Operations	1		
Conference & Meeting			See Chapter 1
Administration			
Cadre	11	5,184	Net SF
Engineering	1		
Pavements / Construction Equip	1		
Electrical	1		
Power Production	1		
Utilities	1		
HVAC	1		
Structural	1		
Emergency Management	1		
Inventory Management	1		
Sustainment Services	1		
Maintenance	1		State Employee
UCC / EOC			
Unit Control Center Training Area			
Structures & Welding Lab Sims			
EA / GeoBase / Surveying Classroom			
Readiness / CBRNE Classroom			
CBT Lab			20 computers
Break Area			
Subtotal		5,628	Net SF
25% Overhead		1,407	
Subtotal		7,035	
Functional Standard		7,000	Gross SF

3

4

6.5.10 Reserve Forces Operational Training - Lightning Force Academy, 30 Personnel

Table 6-17: CATCODE 171-445, Reserve Forces O & T - Lightning Force Academy, 30 Pn

Majors Functions & Breakouts	Authorized Staffing	Target Area (SF)	Remarks
Command & Administration	2	444	Net SF
C-E Systems Manager	1		
Conference & Meeting			See Chapter 1
Administration	1		
Cadre	2	3,966	Net SF
Ground Radio Communications Craftsman	1		
Communications Cable Systems	1		
Training Room / Classrooms / Multi-purpose Area			Sized for 30 personnel
CBT Area			40 Workstations
Practice Labs			
High Reliability Soldering Lab			
Climate Controlled Storage			
Break Area			
PPE Training Bag Storage			
Subtotal		4,410	Net SF
25% Overhead		1,103	
Subtotal		5,513	
Functional Standard		5,500	Gross SF

3
 4

6.6 CATCODE 171-447, Reserve Forces Communications & Electronics Training

- 6.6.1 Provides space for operations and maintenance, administration, shops, and classroom functions; space authorizations for other uses will be handled on a case-by-case basis.
- 6.6.2 Communications and electronics unit types include Combat Communications Group (CCG), Combat Communications Squadron (CCS), Air Control Squadron (ACS), Air Traffic Control Squadron (ATCS), Engineering Installation Squadron (EIS), and similar functions.
- 6.6.3 Combat Communications Group (CCG), 46 Personnel

Table 6-18: CATCODE 171-447, Combat Comm Group, 46 Personnel

Major Functions & Breakouts	Authorized Staffing	Target Area (SF)	Remarks
Command & Administration	9	1,632	Net S
Commander	1		
Vice Commander	1		
Training & Testing			See Chapter 1
Conference & Meeting			See Chapter 1
Secretary / IM	1		
Force Support	1		
Orderly Room	1		
Information Management Center			
T.O. Library			
Unit Education / Training Manager	1		
Division / General Civil Engineer	1		See Note 1
Engineer Craftsman / Facility Manager	1		See Note 1
Chaplains	1		
Operations	7	560	Net SF
Director of Operations	1		
Assistant Director of Operations	1		
Command & Control	2		
Manager / Support Services Supt	1		
Supervisor	1		
Information Journeyman	1		
Operations Center	8	568	Net SF
Superintendent	1		
Control Craftsmen / Operations	5		
Frequency Manager	1		
COMSEC Account Manager	1		
Operations Center	8	568	Net SF
Superintendent	1		
Control Craftsmen / Ops	5		
Frequency Manager	1		
Com Sec Account Manager	1		
Logistics	2	184	Net SF
Management Officer	1		
Plans	1		
Maintenance Control / Support	12	584	Net SF
OIC / Telecommunications Manager	1		
Superintendent / Telecommunication Supply	1		
Satellite & Wideband /Telecommunications Specialist	2		
Cyber Operations	1		
Cyber Systems	6		
Supply Manager	1		

Support	0	171	Net SF
Break Area			
PPE Training Bag Storage			
Subtotal		3,699	Net SF
25% Overhead		925	
Subtotal		4,624	
Functional Standard		4,600	Gross SF

- 1 NOTES:
 2 1. Add 80 Gross SF where this position is funded.
 3 2. Add 4,000 Gross SF if unit is authorized an Eagle Vision UTC 6KVE1.
 4

6.6.4 Combat Communications Squadron Administration, 108 Personnel

Table 6-19: CATCODE 171-447, Combat Comm Sqd Admin, 108 Personnel

Major Functions & Breakouts	Authorized Staffing	Target Area (SF)	Remarks
Command & Administration	9	1,940	Net SF
Commander	1		
First Sergeant	1		
Training & Testing			See Chapter 1
Conference & Meeting			See Chapter 1
Recruiting	1		Includes storage space
Ground Safety	1		
Information Mngt (IM) (3 pers)/Personnel (1 pers)	4		
Mission Support Flight Chief	1		
Training	3	356	Net SF
Training Manager	1		
Emergency Management	1		Includes Storage
Air Force Advisor	1		
Family Support			2 volunteers
Operations / Others	31	3,078	Net SF
Controlled Crypto Items (CCI) Maintenance	2		
CCI Storage			
CCI Secure Area			Only GSA 3-pos. lock required
Open Storage / COMSEC Vault	3		Certified for open 'SECRET' storage
ADPE Storage	1		Includes record storage space
PWCS Storage	1		
UDCC / CFP	8		MOC / Helpdesk Combined Eight personnel per shift
Engineer OIC	1		
Logistics Plans	1		
Maintenance Control	1		
Quality Control	3		
Network Control	1		
Support OIC	1		
Cyber Systems Chief	1		
Support Superintendent	1		
Cyber Operations OIC	1		
Cyber Operations Chief	2		
Cyber Operations Superintendent	1		
RF Transmissions Room	2		
Support	0	255	Net SF
Break Area			
PPE Training Bag Storage			
Subtotal		5,629	Net SF
25% Overhead		1,407	
Subtotal		7,036	
Functional Standard	43	7,000	Gross SF

NOTE:

- Supports 15 personnel located in other facilities (6 Supply and 9 Vehicle Maintenance).

1

Table 6-20: CATCODE 171-447, Combat Comm Sqd Shop

Major Functions & Breakouts	Authorized Staffing	Target Area (SF)	Remarks
Cyber Transport	15		
Cyber Transport Storage			
Cyber Systems Ops	14		
Cyber Systems Operations Storage			
Cyber / RF Transmissions	22		
Cyber / RF Transmissions Storage			
Power Pro / HVAC Shop	9		
Power Pro / HVAC Storage			
Client Service Center	5		
Subtotal		7,550	Net SF
15% Overhead		1,163	
Subtotal		8,913	
Functional Standard	65	8,900	Gross SF

NOTE:

- 1. Additional authorized functional standards under separate CATCODES:
 - a. CATCODE 214-425, Vehicle Maintenance Shop (3,000 Gross SF)
 - b. CATCODE [442-758](#), Base Supply & Equipment Warehouse for mobility, material control receiving/supply, MSRP (see Table 9-3)

2

Table 6-21: CATCODE 171-447, Combat Comm Sqd Admin and Shop Total

Function	Functional Standard (Gross SF)
Combat Communications Squadron Admin	7,000
Combat Communications Squadron Shop	8,900
CCS Total	15,900

3

4

1 6.6.5 Collocated Combat Communications Group / Combat Communications Squadron
 2 Administration, 163 Personnel

3 **Table 6-22: CATCODE 171-447, Collocated Combat Comm Group / Sqd Admin, 163 Personnel**

Major Functions & Breakouts	Staffing	Target (SF)	Remarks
Group Command & Administration	24	3,824	Net SF
Commander	1		
Vice Commander	1		
Training & Testing			See Chapter 1
Conference & Meeting			See Chapter 1
Director of Operations	1		
Telecommunications Manager	1		
Operations Admin / Support / Storage	1		
Operations Engineering	2		
Communications Focal Point (CFP)			9-10 people per shift
Director of Logistics	1		
Logistics Management Officer	1		
Logistics NCOIC	1		
Logistics Support	3		
Logistics Admin / Support / Storage	1		
Director of IM / Personnel	1		
Personnel NCOIC	1		
Personnel Admin / Support / Storage	1		
Training	1		
Training Admin / Support / Storage	1		
Air Force Advisor	1		
Chaplains	2		Requires private counseling areas
Plans Officer	1		
Recruiting	1		Includes storage
Squadron Command & Administration	8	680	Net SF
Commander	1		
First Sergeant	1		
Ground Safety	1		
Information Management / Personnel	4		
Mission Support Flight Chief	1		
Training	3	320	Net SF
Training Manager	1		
Emergency Management	1		
Air Force Advisor	1		
Family Support			2 volunteers
Operations	54	4,642	Net SF
Maintenance Control Officer	1		

Major Functions & Breakouts	Staffing	Target (SF)	Remarks
Maintenance Controllers	8		
ATC Officer	1		
Air Traffic Controllers	3		
Current Operations	3		
Operations OIC	1		
Operations Manager	1		
Controllers	2		
Controlled Crypto Items (CCI) Maintenance	2		
CCI Storage			
CCI Secure Area			Only GSA 3-pos. lock required
Communications Center / COMSEC Vault	3		Certified for open 'SECRET' storage
Record Communications Office	1		Includes record storage space
Voice Communications Office	1		
UDCC / CFP	8		8 personnel per shift
Chief, Maintenance / Chief, Combat Support	1		
Logistics Plans	1		
Maintenance Control	1		
Quality Control	3		
Network Control	2		
Base Level Systems Flight Chief	1		
Base Level Systems Information Manager	2		
Base Level Systems Manager	1		
Base Level Systems Superintendent	1		
Network Systems Flight Chief	1		
Network Systems Flight Manager	1		
Network Systems Flight Superintendent	1		
Network Systems Information Manager (IM)	1		
Satellite (Sat) Systems	1		
Wideband Systems	1		
Support	0	345	Net SF
Break Area			
PPE Training Bag Storage			
Subtotal		9,811	Net SF
25% Overhead		2,453	
Subtotal		12,264	
Functional Standard	163	12,300	Gross SF

- 1 NOTES:
 2 1. Add 3,000 Gross SF for Group Headquarters with UTC 6KMM9.
 3 2. Supports 15 personnel located in other facilities (6 Supply and 9 Vehicle Maintenance).
 4

6.6.6 Collocated Combat Communications Group / Squadron Shop

Table 6-23: CATCODE 171-447, Collocated Combat Comm Group / Sqd Shop

Major Functions & Breakouts	Authorized Staffing	Target Area (SF)	Remarks
Record Communications Shop	12		
Record Communications Storage			
Voice Communications Shop	17		
Voice Communications Storage			
Network Control Shop	9		
Network Control Storage			
Satellite Systems Shop	8		
Satellite Systems Storage			
Wideband Systems Shop	19		
Wideband Systems Storage			
Power Pro / HVAC Shop	9		
Power Pro / HVAC Storage			
Subtotal		6,395	Net SF
15% Overhead		959	
Subtotal		7,354	
Functional Standard		7,400	Gross SF

Table 6-24: CATCODE 171-447, Collocated Combat Comm Group / Sqd Admin and Shop Total

Function	Functional Standard (Gross SF)
Collocated CCG / CCS Admin	12,300
Collocated CCG / CCS Shop	7,400
Collocated CG / CCS Total	19,700

6.6.7 Air Control Squadron (ACS) / Control Reporting Center (CRC), 186 Personnel

Table 6-25: CATCODE 171-447, ACS / CRC, Admin, 186 Personnel

Major Functions & Breakouts	Authorized Staffing	Target Area (SF)	Remarks
Command & Administration	17	2,428	Net SF
Commander	1		
Training & Testing			See Chapter 1
Conference & Meeting			See Chapter 1
First Sergeant	1		
Recruiter	1		
Information Mgt & Personnel	2		
Education & Training	1		
Emergency Management (Readiness)	1		
Independent Medical Services / AeroMed Services	2		
Logistics Plans	1		
Medical Exam / Shot Area	3		Weight / measurement
Airbase Defense / Security	4		
Operations	62	4,003	
Director of Operations	1		
Deputy Director of Operations	1		
Operations Superintendent	1		
Intelligence Officer	1		
Intelligence Support Management	1		
Weapons & Tactics OIC	1		
Weapons & Tactics	2		
Weapons & Tactics OIC	1		
Weapons & Tactics	2		
Stan / Eval OIC	1		
Stan / Eval	2		
Training OIC	1		
Training	2		
Plans OIC	1		
Plans	2		
Current Operations OIC's	6		
Current Operations Supervisor	1		
Current Operations	38		
Operations Storage Lockers			
Maintenance	14	1,008	
Chief of Maintenance	1		
Maintenance Superintendent	1		
Information Management & Personnel	2		
Maintenance / Quality Control	4		
AGE Superintendent	1		
Communications & Information OIC	1		
Mission Systems Supervisor	1		
Satellite Control & Network Systems Supervisors	2		
SATCOM / Wideband Systems Supervisor	1		
Secure Areas	0	3,091	See Note 1
Control & reporting Center Simulation Package (CSP)			14 workstations & associated equipment
Intelligence Equipment - Global Broadcast Service, SIPERNET machines & Internet Broadcast Service			4 workstations & associated equipment
Ground Control Intercept Equipment (MCE OM's)			9 workstations & associated equipment

TBMCS			2 workstations & associated equipment
Classified Material Processing			3 workstations & associated equipment
Crypto Operations Secure Area			
Communications Center/COMSEC Vault			
SIPERNET/Secure VTC			
Crew Briefing Room			Sized for 45 personnel @ 24 SF/PP
Support	0	379	Net SF
Break Area			
PPE Training Bag Storage			
	Subtotal	10,909	Net SF
	25% Overhead	2,727	
	Subtotal	13,636	
	Functional Standard	13,600	Gross SF

1
 2
 3
 4
 5
 6
 7
 8
 9

NOTES:

- The secure area must be certified for "OPEN SECRET".
- This standard also supports 8 Vehicle Maintenance and 5 Material Control personnel that are physically located in another facility.

Table 6-26: CATCODE 171-447, ACS / CRC Shop

Major Functions & Breakouts	Authorized Staffing	Target Area (SF)	Remarks
Theater Deployable Communications / Integrated Communications Access Package (TDC / ICAP)			
Ground Radar Systems Maintenance Shop	9		
Ground Radar Systems Maintenance Storage			
Computer Systems - Satellite Control & Network	17		
Computer Systems Maintenance Storage			
Technical Control	7		
Technical Control Storage			
Secure Communications Systems	8		
Secure Communications Systems Storage			
Ground Radio	11		
Ground Radio Storage			
SATCOM / Wideband Systems	26		
SATCOM / Wideband Systems Storage			
AGE / HVAC	15		
AGE / HVAC Storage			
	Subtotal	11,226	Net SF
	15% Overhead	1,684	
	Subtotal	12,910	
	Functional Standard	12,900	Gross SF

10
 11

Table 6-27: CATCODE 171-447, ACS / CRC Admin and Shop Total

Function	Functional Standard (Gross SF)
ACS / CRC Admin	13,600
ACS / CRC Shop	12,900
ACS / CRC Total	26,500

NOTES:

1. The following primary additional facility standards are also part of the Air Control Squadron mission set:
 - [CATCODE 214-422, Vehicle Service Rack](#) – 1 each
 - [CATCODE 214-425, Vehicle Maintenance Shop](#) – IAW Vehicle Equivalents per Table 7-12 (5,400 GSF)
 - [CATCODE 214-428, Vehicle Operations Parking Shed](#) – IAW Vehicle Equivalents per Table 7-13 (8,000 GSF)
 - [CATCODE 214-467, Refueling Vehicle Shop](#) – IAW Table 7-14 (1,100 GSF)
 - [CATCODE 442-628, Base Supply & Equipment Shed](#) – IAW Table 9-2 (6,000 GSF)
 - [CATCODE 442-758, Base Supply & Equipment Warehouse](#) – IAW Table 9-3 (13,600 GSF)
 - [CATCODE 610-121, Vehicle Operations Administration](#) – IAW Table 10-1, Note 2 (700 GSF)
 - [CATCODE 610-122, Base Supply Administration](#) - 800 GSF if GSU per Table 10-6; 400 GSF if not a GSU
 - [CATCODE 852-261, Vehicle Parking Operations](#) – IAW Table 13-1
2. Secondary / support CATCODES can also be authorized for this mission set on a case by case basis (e.g. equipment pad, HAZMART Storage, Base Engineer Shed / Maintenance Shop, Traffic Check House for GSU’s, etc.)

6.6.8 Contingency Response Group, 160 Personnel

Table 6-28: CATCODE 171-447, Contingency Response Group Admin, 153 Personnel

Major Functions & Breakouts	Authorized Staffing	Target Area (SF)	Remarks
Contingency Respon Group	12	2,632	Net SF
Commander	1		
Deputy Commander	1		
Group Superintendent	1		
First Sergeant	1		
Admin Personnel	5		
Unit Deployment Manager	1		
Group FM	1		
Education and Training	1		
Conference and Meeting			See Chapter 1
Training and Testing			See Chapter 1
Technical Library			
Storage			
Contingency Respon Squadron	103	7,968	
Commander	1		
Operations OIC	1		
LZ/DZ Operations	12		
Medical			
Flight Surgeon	1		
Public Health	1		
Bioenvironmental	1		
Medical Admin	1		
Engineering OIC	1		
Civil Engineering	1		
Security OIC	1		
Security NCOIC	1		
Security Forces	31		Mainly teaming/operations space
Intel Vault	3		
Intel OIC	1		
Logistics OIC	1		
Logistics and Mission Support	6		
Transportation	22		
Contracting	1		
Aircraft Mx, Alpha	8		
Weather	2		
Mission Systems	6		
Weapons Vault w/ issue & clearing			
Storage			Includes Mob bags and Cold Weather
Cont Response Spt Squadron	38	2,312	
Commander	1		
Comm Maintenance	2		
Aerial Port OIC	1		
Aerial Port	13		
A/C MX/AGE	2		Cubicles for Aircraft Mx, AGE & Power Pro moved to shops
Public Affairs Craftsman	1		
Engineering Craftsman	1		
Operation, Logistics	8		
Weather	1		
Air Operations OIC	1		
Air Operations	7		
Support	0	337	Net SF
Break Area			

PPE Training Bag Storage			
Subtotal		13,249	Net SF
25% Overhead		3,312	
Subtotal		16,561	
Functional Standard	153	16,600	Gross SF

1
2

Table 6-29: CATCODE 171-447, Contingency Response Group Shop, 7 Personnel

Major Functions & Breakouts	Authorized Staffing	Target Area (SF)	Remarks
Aerospace Ground Equipment	4		
Power Production	3		
Subtotal		1,400	Net SF
15% Overhead		210	
Subtotal		1,610	
Functional Standard	7	1,600	Gross SF

3
4

Table 6-30: CATCODE 171-447, Contingency Response Group, Admin and Shop Total

Function	Functional Standard (Gross SF)
CRG Admin / Operations / Support	16,600
CRG Shop	1,600
CRG 160 personnel Total	18,200

5
6
7
8
9
10
11
12

NOTES:

- Additional authorized functional standards under separate CATCODES:

[CATCODE 442-758, Base Supply & Equipment Warehouse](#) (9,000 Gross SF) (see Table 9-3)

[CATCODE 145-921, overhead Protection](#) (5,600 Gross SF), covered space for 5 tents reconstitution

[CATCODE 214-428, Vehicle Ops Parking Shed](#) (5,800 Gross SF)

[CATCODE 214-426, Vehicle Ops Heated Parking](#) (1,100 Gross SF)

6.6.9 Air Traffic Control Squadron, 55 Personnel

Table 6-31: CATCODE 171-447, Air Traffic Control Sqd Admin

Major Functions & Breakouts	Authorized Staffing	Target Area (SF)	Remarks
Command & Administration	9	1,614	Net SF
Commander	1		
First Sergeant	1		
Training & Testing			See Chapter 1
Conference & Meeting			See Chapter 1
Safety	1		
Admin	1		
Training NCOIC	1		
Personnel NCOIC	1		
Logistics Plans NCOIC	1		Includes classified storage
Maintenance / Operations Administration	1		
Air Traffic Manager	1		
Operations	16	3,513	Net SF
Chief, Train. & Standardization	1		
Chief, ATC Operations	1		
Chief, ATC Stan Eval	1		
Chief, ATC Training	1		
Chief, Air Traffic Manager	1		
Radar Chief Controller	1		
Tower simulator			
Tower Chief Controller	1		
Terminal Instrument Procedures-TERPS			Map cases, drawing boards, etc.
Base ATCALs			Additional Space to support WX, VORTAC and ILS monitors
Storage			
Chief of Maintenance	1		
Maintenance Control	1		
Maintenance Support	1		
Radio Maintenance NCOIC	1		
Airfield Systems NCOIC	1		
Material Control NCOIC	1		
Material Control Office	1		
Power Production NCOIC	2		
Support	1	235	Net SF
Break Area			
PPE Training Bag Storage			
Subtotal		5,362	Net SF
25% Overhead		1,341	
Subtotal		6,703	
Functional Standard		6,700	Gross SF

1

Table 6-32: CATCODE 171-447, Air Traffic Control Sqd Shops

Major Functions & Breakouts	Authorized Staffing	Target Area (SF)	REMARKS
Radar Maintenance Shop	8		
Radar Maintenance Storage			
Radio Maintenance Shop	10		
Radio Maintenance Storage			
METNAV Maintenance Shop	3		
METNAV Maintenance Storage			
Telephone Maintenance Shop	3		
Telephone Maintenance Storage			
Power Production / HVAC Shop	5		
Power Production / HVAC Storage			
Subtotal		2,256	Net SF
15% Overhead		338	
Subtotal		2,594	
Functional Standard		2,600	Gross SF

2

Table 6-33: CATCODE 171-447, Air Traffic Control Sqd Admin and Shops Total

Function	Functional Standard (Gross SF)
ATCS Admin	6,700
ATCS Shops	2,600
ATCS Total	9,300

3
 4
 5
 6

NOTE:

1. This function is also authorized space for [CATCODE 134-341 Mobile Radar Support Facility](#).

6.6.10 Engineering Installation Squadron Administration, 112 Personnel

Table 6-34: CATCODE 171-447, Engineering Installation Sqd Admin

Major Functions & Breakouts	Authorized Staffing	Target Area (SF)	Remarks
Command & Administration	12	2,296	Net SF
Commander	1		
Air Commander (Deputy Commander)			
Training & Testing			See Chapter 1
Conference & Meeting			See Chapter 1
First Sergeant	1		
Unit Administration	2		
Media Center			
Information Management	1		
Personnel	1		
Systems Telecommunications Engineering Manager (STEM)	2		
Training NCOIC	1		
Recruiter	1		Includes storage space
Ground Safety	1		
Emergency Management	1		
Operations	44	2,608	Net SF
Engineering Management Chief	4		
Engineering Management Superintendent	2		
Engineering Management	6		
Engineering Assistant (CADD)	6		
Installations Chief	1		
Installation Officer	1		
Installations Support Section	2		
Installations Wire Chief	1		
Cable / Antenna Systems NCOIC	1		
Installations Electronics Chief	1		
RF Transmission Systems NCOIC	1		
Workload Control Superintendent	1		
Workload Control	1		
Logistics Chief	1		
Vehicle Maintenance	8		
Logistics	1		
Logistics Plans / Mobility	2		
Quality Chief	1		
Quality Assurance	3		
Support	0	280	Net SF

Break Area			
PPE Training Bag Storage			
Subtotal		5,184	Net SF
25% Overhead		1,296	
Subtotal		6,480	
Functional Standard		6,500	Gross SF

- 1 NOTE:
 2 1. Supports 15 personnel located in other facilities (5 Supply and 10 Vehicle Maintenance).
 3

4 **Table 6-35: CATCODE 171-447, Engineering Installation Sqd Shops**

Major Functions & Breakouts	Authorized Staffing	Target Area (SF)	Remarks
Airfield Systems Shop	13		
Airfield Systems Storage			
RF Transmissions System Shop	13		
RF Transmissions System Storage			
Cable / Antenna Systems Shop	42		
Cable/Antenna Systems Storage			
Subtotal		6,050	Net SF
15% Overhead		908	
Subtotal		6,958	
Functional Standard		7,000	Gross SF

- 5 NOTE:
 6 1. Additional functional standards associated with this mission set:
 7 a. [CATCODE 214-422, Vehicle Service Rack](#)
 8 b. [CATCODE 214-425, Vehicle Maintenance Shop](#) - (3,300 Gross SF)
 9 c. [CATCODE 442-758, Base Supply and Equipment Warehouse](#) - IAW Table 9-3 (7,000 Gross SF)
 10 d. [CATCODE 852-261, Vehicle Parking Operations](#) – IAW Table 13-1
 11

12 **Table 6-36: CATCODE 171-447, Engineering Installation Sqd Admin and Shops Total**

Function	Functional Standard (Gross SF)
EIS Admin	6,500
EIS Shop	7,000
EIS Total	13,500

13
 14

6.6.11 Information Warfare Aggressor Squadron, 104 Personnel

Table 6-37: CATCODE 171-447, Info Warfare Aggressor Sqd, 104 Personnel

Major Functions & Breakouts	Authorized Staffing	Target Area (SF)	Remarks
Command & Administration	8	1,932	Net SF
Commander	1		
First Sergeant	1		
Training & Testing			See Chapter 1
Conference & Meeting			See Chapter 1
Unit Training Manager	1		
Information Management, Personnel	2		
Director of Operations	1		
Operations Superintendent	1		
Judge Advocate General (JAG)	1		
Aggressor Operations Flight	21	1,280	Net SF
Flight Commander	1		
Superintendent	1		
Information Management	1		
Alpha Team	6		
Bravo Team	6		
Charlie Team	6		
Classified Classroom			Sized for 12 Personnel
Storage			
Computer Systems Vulnerability Flight	27	1,616	Net SF
Flight Commander	1		
Alpha Team	7		
Bravo Team	7		
Charlie Team	6		
Delta Team	6		
Info Technology Assessment & Testing Lab			Sized for 14 Personnel
Storage			
Computer Network Operations Flight	34	1,952	Net SF
Flight Commander	1		
Information Management	1		
Alpha Team	8		
Bravo Team	8		
Charlie Team	8		
Delta Team	8		
Assessment Lab			Sized for 16 Personnel
Storage			
Computer Information Programs Flight	11	984	Net SF
Flight Commander	1		
Information Management	1		
Operations Training OIC	1		
Operations Training Office	2		
Stan / Eval OIC	1		
Plans, Programs, Schedule & Logistics OIC	1		
Plans, Programs, Schedule & Logistics NCOIC	1		
Plans, Programs, Schedule & Logistics Info Management	1		
IT Range Management OIC	1		
IT Range Management NCOIC	1		
Intel Vault / Secure Space	3	1,400	Net SF
Combined Intel Vault and Secure Space	3		
Common Areas	0	1,658	Net SF
Computer Applications Classroom #1			Sized for 12 Personnel
Computer Applications Classroom #2			Sized for 12 Personnel
Computer Applications Classroom #3			Sized for 12 Personnel

Computer Applications Classroom #4			Sized for 12 Personnel
Break Area			
Library			
Storage, Training Aids			
PPE Training Bag Storage			
Subtotal		10,772	Net SF
25% Overhead		2,693	
Subtotal		13,465	
Functional Standard		13,500	Gross SF

1

1 6.6.12 Cyber Ops Sqd Defense, Hunter, 73 Personnel

2 **Table 6-38: CATCODE 171-447, Cyber Ops Sqd Defense, Hunter, 73 Personnel**

Major Function & Breakouts	Authorized Staffing	Target Area (SF)	Remarks
Command & Administration	8	736	Net SF
Commander			
Superintendent			
Education & Training			
Personnel Craftsmen			
First Sergeant			
Chief, Stds & Eval, Training			
NCOIC, Stds & Eval, Training			
Training & Testing		1,275	Net SF
Training & Testing / VTC Room (JWICS)			
Unclass Trng Room			
Conference & Meeting		1,350	Net SF
Conference / Meeting / Testing / Student Flight			
Classified Conference Room			
Cyber Maintenance Branch	15	2,688	Net SF
SSR & SSO + Mantrap			
Flight Commander			
Flight NCOIC			
Cyber System Maintenance			
Cyber Infrastructure Maintenance			
Cyber Systems Maintenance			
Cyber Range/Servers Bay			
Storage Room (SCIF)			
Cyberspace Ops Branch	50	3,360	Net SF
Director of Operations			
Weapons & Tactics OIC			
Mission Plans			
Alpha Flight, Flight Commander			
Alpha Flight, Flight NCOIC			
Alpha Flight, Mission Element 1			
Alpha Flight, Debrief Room			
Bravo Flight, Flight Commander			
Bravo Flight, Flight NCOIC			
Bravo Flight, Mission Element 2			
Bravo Flight, Debrief Room			
Charlie Flight, Flight Commander			
Charlie Flight, Flight NCOIC			
Charlie Flight, Mission Element 3			
Charlie Flight, Debrief Room			
Intelligence Flight, Flight NCOIC			
Intelligence Flight, CPT Blue Team Crew			
Mission Training, Flight Commander			
Mission Training, Training NCOIC			

Support	0	664	Net SF
Storage Room			
File Room			
PPE Training Bag Storage			
Break Area			
Subtotal		10,073	Net SF
25% Overhead		2,518	
Subtotal		12,591	
Functional Standard	73	12,600	Gross SF

- 1 NOTE:
 2 1. Second collocated COS will be at 11,000 Total Gross SF.
 3
 4
 5

1 6.6.13 Field Maintenance Communications Electronics, MQ-9, 29 Personnel

2 **Table 6-39: CATCODE 171-447, Field Maintenance Comm Electronics, MQ-9, 29 Personnel**

Major Function & Breakouts	Authorized Staffing	Target Area (SF)	Remarks
Field Maintenance Communications Electronics	29	1,968	Net SF
Superintendent	1		
NCOIC	1		
Cyber Transport Systems	21		
RF Transmission Sytems	6		
Support	0	144	Net SF
Storage Room			
Break Area			
Subtotal		2,112	Net SF
25% Overhead		528	
Subtotal		2,639	
Functional Standard		2,600	Gross SF (See Note)

3 NOTE: If the function is collocated with another maintenance function, then the overhead factor is reduced to 10% and the
 4 Functional Standard is 2,300 Gross SF.

6.6.14 Joint Communications Support Squadron (JCSS), 200 Personnel

Table 6-40: CATCODE 171-447, Joint Communications Support Sqd (JCSS), 200 Personnel

Major Function & Breakouts	Authorized Staffing	Target Area (SF)	Remarks
Command & Administration	5	1,944	Net SF
Commander	1		
Superintendent	1		
First Sergeant	1		
Knowledge Ops/Info Mgt	1		
Conference & Meeting			See Chapter 1
Training & Testing			See Chapter 1
Recruiting	1		
Mission Support Flight	49	3,560	Net SF
OIC	1		
Flight Chief	1		
Manpower & Personnel NCOIC	1		
Manpower & Personnel	1		
Education & Training	2		
Health & Services Mgt	1		
SA & Maintenance Control			
SA Main Control Super	1		
SA	5		
Plans			
OIC	1		
Plans Chief/Super	1		
Senior Plans	1		
Plans	2		
Combat Logistics Support			
Combat Logistics Senior	1		
Supply Management	5		See Note 1
Log Plans	1		
Security Forces	2		
Emergency Management	1		
Weapons Vault			
CBRNE/Combat Arms Classroom			Sized for 21 personnel with a 24" x 36" each
Weapons Maintenance Area			
Weapons Cleaning/Degreasing			
Combat Logistics Support			
Maint Support Senior	1		
HVAC	3		Admin/shop space included
Power Pro	8		Admin/shop space included
Vehicle Maintenance	8		See Note 2
Cyber Ops	146	5,208	Net SF
Director of Operations	1		
J2 Secure Vault			
Cyber Surety	2		
COMSEC Storage			
SIPR Café			
A Flight			
Flight Commander	2		
Flight Chief	1		
Element NCOIC	3		
EEP Team Chief	9		
IEP Team Chief	6		
EEP Personnel	36		Hotel space
IEP Personnel	12		Hotel space
B Flight			

Flight Commander	2		
Flight Chief	1		
Element NCOIC	3		
EP Team Chief	10		
IEP Team Chief	4		
EEP Personnel	44		Hotel space
IEP Personnel	10		Hotel space
Equipment & Training Labs	0	5,950	Net SF
Voice Training Lab			
Data Training Lab			
IP Modem Training Lab			
IEP Equipment			
EEP Equipment			
JTF Equipment			
Support		400	
Break Area			
PPE Training Bag Storage			
Subtotal		17,062	Net SF
25% Overhead		4,266	
Subtotal		21,328	
Functional Standard		21,300	Gross SF

NOTE:

1. Per Table 10-6, Supply Personnel are authorized 1,000 SF for GSU under [CATCODE 610-122, Base Supply Admin](#)
2. Per Table 10-1, Note 3, Vehicle Maintenance Personnel are authorized 700 SF under [CATCODE 610-121, Vehicle Operations Admin](#)
3. Additional functional standards associated with this mission set:
 - a. [CATCODE 442-628, Base Supply Equipment Shed](#) – IAW Table 9-2 (5,400 SF)
 - b. [CATCODE 442-758, Base Supply & Equipment Warehouse](#) – IAW Table 9-3 (8,000 SF)
 - c. [CATCODE 219-944, BCE Maintenance Shop](#) – IAW Table 7-34 (1,000 SF)
 - d. [CATCODE 214-425, Vehicle Maintenance Shop](#) – IAW Table 7-13 for 139.6 VEs (4,900 SF)
 - e. [CATCODE 852-262, Non-organizational Vehicle Parking](#) – IAW Para 13.3.2 (5,250 SY)
 - f. [CATCODE 852-261, Vehicle Parking Operations](#) – IAW Table 13-1 for 139.6 VEs (5,825 SY)
 - g. [CATCODE 442-257, HAZMAT Storage](#) – IAW Table 9-1 for GSU (300 SF)
 - h. [CATCODE 219-947, BCE Storage Shed](#) – IAW Table 7-37 for GSU (1,000 SF)

6.6.15 Air Operations Group (AOG) with JAOC and JWIC, 145 Personnel

Table 6-41: CATCODE 171-447, AOG with JAOC and JWIC, 145 Personnel

Major Function & Breakouts	Authorized Staffing	Target Area (SF)	Remarks
Command & Administration	15	2,398	Net SF
Commander	1		
Deputy Commander	1		
First Sergeant	1		
Recruiter	1		
Space & Missile	1		
AF Ops staff Off	1		
Personnel	1		
Education & Training	1		
DSG Admin	2		
Chaplain Section	4		
AOC JAG	1		
Conference & Meeting			See Chapter 1
Training & Testing			See Chapter 1
Operations Admin	101	4,280	Net SF
Combat Operations	4		
Defensive Operations	8		
Interface Control	7		
Offensive Operations	8		
AOC Reports Specialty Team	3		
SIDO	3		
AOC Weather Specialty Team	2		
Combat Plans	3		
ATO Production	4		
AOC Airspace Management Specialty Team	5		
C2 Planning	4		
MAAP (Master Air Attack Plan)	8		
AOC Special Technical Operations (STO) Specialty Team	4		
Targeting Effects Operations	1		
Intelligence Surveillance and Reconnaissance	1		
Analysis Correlation and Fusion	13		
Targets & Combat Assessment	2		
ISR Operations	7		
Processing Exploitation and Dissemination	1		
Targeting and Tactical Assessment	2		
Operations Plans	1		
Strategy	1		
Strategy Guidance	4		
Operational Assessment	4		
Communications Support	29	716	Net SF
Communications Focal Point (CFP) Tm	11		
Data Links Team	4		
Networks Team	8		
Systems Team	6		
EEP Equipment			
JTF Equipment			
Mission Operations	0	9,600	Net SF
JAOC Ops Floor		8000	
JWIC		1600	

Support	0	1,800	Net SF
Storage			
UPS			
Network			
Network Admin			
Break Area			
Subtotal		18,794	Net SF
25% Overhead		4,699	
Subtotal		23,493	
Functional Standard		23,500	Gross SF

1
 2

6.6.16 Air Operations Group (AOG), with JAOC, 144 Personnel

Table 6-42: CATCODE 171-447, AOG with JAOC, 144 Personnel

Major Function & Breakouts	Authorized Staffing	Target Area (SF)	Remarks
Command & Administration	23	3,018	Net SF
Operations Commander	1		
Support Commander	1		
Cyberspace Operations	1		
Executive	2		
First Sergeant	1		
Protocal	1		
Deputy Commander	1		
Commanders Support Staff	7		
Chaplain	1		
Judge Advocate	1		
Public Affairs	2		
Surgeon Section	4		
Conference & Meeting			See Chapter 1
Training & Testing			See Chapter 1
Operations Admin	121	4,576	Net SF
Manpower Personnel and Services	7		
Intelligence Surveillance and Reconnaissance	7		
Operations	21		
Logistics	1		
Logistics I	1		
Maintenance	11		
Logistics Readiness	9		
Logistics Plans	5		
Plans and Requirements	4		
Communications	2		
Operations	10		
Installations and Mission Support	1		
The Civil Engineer	3		
Engineering	6		
Contracting	2		
Security Forces	3		
Studies Analyses Asmnts and Lsns Lrnd	5		
C2 Planning	12		
Operations	1		
Mission Systems	10		
Mission Operations	0	8,000	Net SF
JAOC Ops Floor		8000	
Support	0	1,200	Net SF
Storage			
Network			
Network Admin			
Break Area			
Subtotal		16,794	Net SF
25% Overhead		4,199	
Subtotal		20,993	
Functional Standard	144	21,000	Gross SF

6.6.17 Air Operations Group (AOG), admin only (no Ops floor), 131 Personnel

Table 6-43: CATCODE 171-447, AOG, admin only (no Ops floor), 131 Personnel

Major Function & Breakouts	Authorized Staffing	Target Area (SF)	Remarks
Command & Administration	5	1,798	Net SF
Commander	1		
Executive	1		
First Sergeant	1		
CC Support Staff	2		
Conference & Meeting			See Chapter 1
Training & Testing			See Chapter 1
Air Taskings	52	3,776	Net SF
Air Mobility	10		
Aeromedical Evacuation Control	5		
Air Control	4		
Air Mobility Control	22		
Air Refueling Control	11		
Operations	53	4,064	Net SF
Defensive Operations	9		
Offensive Operations	9		
ATO Production	4		
AOC Airspace Management Specialty Team	5		
MAAP	8		
Operations	1		
Intelligence C Flt	1		
Analysis Correlation And Fusion	8		
ISR Operations	4		
Strategy Guidance	4		
Communications Support	21	1,456	Net SF
Communications Focal Point (CFP) Tm	7		
Data Links Team	3		
Networks Team	5		
Systems Team	6		
Support	0	600	Net SF
Storage			
Break Area			
Subtotal		11,694	Net SF
25% Overhead		2,924	
Subtotal		14,618	
Functional Standard	131	14,600	Gross SF

6.6.18 Air Operations Group (AOG), with JAOC, AFFOR & JWIC, 250 Personnel

Table 6-44: CATCODE 171-447, AOG with JAOC, AFFOR & JWIC, 250 Personnel

Major Function & Breakouts	Authorized Staffing	Target Area (SF)	Remarks
Command & Administration	16	4,130	Net SF
Commander	1		
Deputy Commander	1		
Director of Operations	1		
Deputy Director of Operations	1		
First Sergeant	1		
CC Support Staff	5		
Chaplain	1		
Judge Advocate	1		
AOC JAG Tm	1		
Standardization and Evaluation	1		
Public Affairs	2		
Conference & Meeting			See Chapter 1
Training & Testing			See Chapter 1
Air Taskings	104	3,900	Net SF
Manpower Personnel and Services	3		
Services	2		
Intel Surveillance & Reconnaissance	4		
Operations	2		
Airspace Ranges & Airfield Ops	1		
Current Operations	3		
Training Operations	1		
Future Operations	2		
Exercises	1		
Logistics	1		
Maintenance	5		
Logistics Readiness	5		
Logistics Plans	4		
Plans and Requirements	6		
Communications	12		
The Civil Engineer	1		
Engineering	3		
Contracting	3		
Security Forces	2		
Strategic Plans and Programs	5		
Air Mobility	5		
Air Control	6		
Air Mobility Control	16		
Air Refueling Control	11		
Operations	130	4,028	Net SF
Combat Operations	2		
Defensive Operations	9		
Interface Control	7		
Offensive Operations	8		
AOC Reports Specialty Team	3		
ATO Production	4		
AOC Airspace Management Specialty Team	5		
C2 Planning	3		
MAAP	8		
AOC Special Technical Operations (STO) Specialty Team	1		
Targeting Effects	1		

Operations	1		
Intelligence Surveillance & Reconnaissance	2		
Analysis Correlation And Fusion	8		
Targets & Combat Assessment	10		
ISR Operations	14		
Comm/Information	2		
Mission Systems	10		
Radio Systems	3		
Operations	14		
Plans & Resources	6		
Strategy	1		
Strategy Guidance	4		
Operational Assessment	4		
Communications Support	29	1,216	Net SF
Communications Focal Point (CFP) Tm	11		
Data Links Team	4		
Networks Team	8		
Systems Team	6		
EEP Equipment			
JTF Equipment			
Mission Operations	0	16,100	Net SF
JAOC Ops Floor			
AFFOR Ops Floor			
JWIC			
Support	0	2,000	Net SF
Storage			
UPS			
Network			
Network Admin			
Break Area			
Subtotal		30,658	Net SF
25% Overhead		7,665	
Subtotal		38,323	
Functional Standard	250	38,300	Gross SF

1
 2

6.6.19 Air Operations Group (AOG), with JAOC, AFFOR & JWIC, 301 Personnel

Table 6-45: CATCODE 171-447, AOG with JAOC, AFFOR & JWIC, 301 Personnel

Major Function & Breakouts	Authorized Staffing	Target Area (SF)	Remarks
Command & Administration	30	5,288	Net SF
Commander	1		
Deputy Commander	1		
Executive Officer	1		
Director of Operations	1		
Deputy Director of Operations	1		
Personnel Officer	2		
First Sergeant	1		
Protocal	1		
WGM & Tech Support	2		
CC Support Staff	6		
Judge Advocate	2		
Public Affairs	2		
Surgeon	9		
Conference & Meeting			See Chapter 1
Training & Testing			See Chapter 1
Air Taskings	139	4,728	Net SF
Manpower Personnel and Services	8		
Services	3		
Intel Surveillance & Reconnaissance	8		
Operations A3	12		
Logistics	3		
Logistics L	1		
Maintenance	8		
Logistics Readiness	6		
Logistics Plans	2		
Plans and Requirements	6		
Communications	2		
Operations A6	10		
Installations & Mission Support	1		
The Civil Engineer	3		
Contracting	4		
Security Forces	4		
Studies Analyses Asmnts & Lsns Lrnd	2		
Air Mobility	10		
Air Control	5		
Air Control	4		
Air Mobility Control	22		
Air Refueling Control	11		
Financial Management & Comptroller	4		
Operations	106	4,560	Net SF
Combat Operations	2		

Defensive Operations	8		
Interface Control	10		
Offensive Operations	12		
AOC Reports Specialty Team	5		
AOC Weather Specialty Team	1		
Combat Plans	1		
ATO Production	5		
AOC Airspace Management Sply Tm	5		
C2 Planning	4		
MAAP	8		
AOC Spl Tech Ops (STO) Sply Tm	1		
Operations	5		
Intelligence Surveillance & Reconnaissance	2		
Analysis Correlation And Fusion	8		
Targets & Combat Assessment	5		
ISR Operations	14		
Strategy	1		
Strategy Guidance	5		
Operational Assessment	4		
Communications Support	26	1,180	Net SF
Communications Focal Point (CFP) Tm	9		
Data Links Team	6		
Networks Team	5		
Systems Team	6		
EEP Equipment			
JTF Equipment			
Mission Operations	0	16,100	Net SF
JAOC Ops Floor			
AFFOR Ops Floor			
JWIC			
Support	0	2,250	Net SF
Storage			
UPS			
Network			
Network Admin			
Break Area			
Subtotal		34,106	Net SF
25% Overhead		8,527	
Subtotal		42,633	
Functional Standard	301	42,600	Gross SF

1
 2

6.7 CATCODE 171-449, Reserve Forces Aeromedical Evacuation Training

This function provides space for the training and operation of Aeromedical Evacuation (AE) units, with areas designated for the commander, chief nurse, aircrew briefing, classrooms, medical and mobility storage, unit administration, training, and the control center.

Table 6-46: CATCODE 171-449, AeroMed Evac Training, 117 Personnel

Major Functions & Breakouts	Authorized Staffing	Target Area (SF)	Remarks
Command & Administration	3	1,500	Net SF
Commander	1		
Training & Testing			See Chapter 1
Conference & Meeting			See Chapter 1
Executive Officer	1		
First Sergeant	1		
Operations	33	2,816	Net SF
Orderly Room - Technician & Information Management Specialist	2		
T.O. Library			
Senior Health Technician	1		
Chief Nurse	1		
Aeromedical Services Supt	1		
Radio Communication Systems Supt	1		
Unit Education & Training Manager	1		
Stan / Eval - OIC	2		
Stan / Eval - NCOIC	5		
Operations - OIC	2		
Operations - NCOIC	5		
Safety - OIC	2		
Scheduling - OIC	2		
Biomedical Equipment Team	3		
Medical Supply Support (MSS)	2		
Medical Critical Care Team (MCCT) - OIC	1		
MCCT Clinical Nurse	1		
MCCT Cardiopulmonary (CP) Specialist	1		
Crew Management Cell	6	440	Net SF
Health Services Admin	1		
Flight Nurse	1		
Health Services Management	2		
Aeromedical Services	2		
In-flight Medical Care	5	376	Net SF
Flight Nurse	2		
Aeromedical Services	3		
Liaison Team	4	312	Net SF

Health Services Admin	1		
Flight Nurse	1		
Radio Communication System	2		
Support Cell	4	256	Net SF
AGE Specialist	1		
Ground Radio Communication	1		
Health Services Management	1		
Medical Material	1		
Mobile Staging Facility	62	2,504	Net SF
Health Services Admin	1		
Flight Nurse	1		
Health Services Management	1		
Aeromedical Services	7		
Radio Communication System	2		
Radio Operations Room	10		
Flight Crews	35		
Crew Briefing Room			Sized for 12 personnel
Aircrew Flight Equipment Maintenance	5		
Support	0	2,120	Net SF
Break Area			
PPE Training Bag Storage			
Built-up pallet area			Six - 463L pallets
Built-up container area			Three pallets - 6 units
Built-up litter area			Three pallets - 9 units
Aircrew Flight Equipment Maintenance			
Drug secured storage area			
Subtotal		10,324	Net SF
25% Overhead		2,581	
Subtotal		12,905	
Functional Standard		12,900	Gross SF

- 1 NOTE:
 2 1. Typical ANG Aeromedical Evacuation Squadron staffing varies from 100 to 120 personnel.
 3
 4

6.8 CATCODE 171-450, Reserve Forces Medical Training / Administration

6.8.1 Provides space for medical training and administration, with areas designated for the commander, chief nurse, physical and dental exams, immunization, classrooms, nurses' station, bio-environmental engineering and environmental health, and medical administration to support a flying unit.

6.8.2 Reserve Forces Medical Training, 63 Personnel

Table 6-47: CATCODE 171-450, Med Training Admin

Major Functions & Breakouts	Authorized Staffing	Target Area (SF)	Remarks
Command & Administration	23	2,794	Net SF
Commander	1		
First Sergeant	1		
Training & Testing			See Chapter 1
Conference & Meeting			See Chapter 1
Health Services Administrator	1		
Medical Administration Officer	1		
Group Superintendent	1		
Medical Education Training Manager	1		
Physician's Office	4		
Administrative Office	3		
Optometry	2		Optometrist & tech
Medical Material	1		
Bio-Environmental Engineer (BEE)	3		1 Section Chief, 2 Craftsman
Aeromedical Physician's Office	1		Flight Surgeon
Public Health Office	3		1 Section Chief, 2 Craftsman
Operations	22	2,236	Net SF
Laboratory	1		
Dental Office	3		
Nurse Administrator	1		
Nursing Services	9		
Outpatient Records	2		
Medical Record Storage			
Dental Records	1		Dental technician
Patient Administration	2		Overflow for 4 A0's
Medical Readiness	2		
Mental Health	1		
Mobility Training Storage (PPE)			
Medical Control Center Area			
Subtotal		5,030	Net SF
25% Overhead		1,258	
Subtotal		6,228	
Functional Standard		6,300	Gross SF

Table 6-48: CATCODE 171-450, Med Training (Training Area)

Major Functions & Breakouts	Authorized Staffing	Target Area (SF)	Remarks
Patient Waiting Area			
Patient Processing			
Examination Room	4		
Electrocardiogram (EKG) Room	2		
Optometry Exam	1		
Optometry Screening Room	1		
Dental Exam	2		
Dental X-Ray			
Audio Testing and Admin	2		
Immunization Room	2		
Bio-Environmental Engineering (BEE) Laboratory	2		Equip training and proficiency testing
Public Health			ANAM Testing (pre / post deployment testing)
Equipment Staging			Space to accommodate training equipment (i.e. mannequins, SABC items)
Clinical Laboratory	1		Collection / storage area separate from testing & processing
Vital Signs			
Biomedical Equipment Maintenance and Storage	1		
Medical Material Storage			
Subtotal		3,219	Net SF
25% Overhead		805	
Subtotal		4,024	
Functional Standard		4,000	Gross SF

Table 6-49: CATCODE 171-450, Med Training Admin & Training

Function	Functional Standard (Gross SF)
Medical Admin	6,300
Medical Training	4,000
Medical Group Total	10,300

NOTES:

1. Add 250 Gross SF to all MDG's that are not collocated with an AD host for Medical C-CBRN Home Station Response Equipment IAW presidential directive 5,8 & 11, AFI 10-2501, AFI 41-106, AFI-41-209 & AFTTP 3-42.32.
2. The average ANG Medical Group manning is 71 personnel. Project scope for unit staffing differences must be dealt IAW Chapter 1, paragraph 1.7.8 as required.

6.8.3 Tenants Units, 38 Personnel (Collocated Facility)

Table 6-50: CATCODE 171-450, Med Training, Tenant

Major Functions & Breakouts	Authorized Staffing	Target Area (SF)	Remarks
Aeromedical Physician’s Office	1		
Health Services Administrator’s Office	1		
Physician’s Office (4)	4		
Clinic Administration	6		
Administrative Office	3		
Medical Material	3		
Bio-Environmental Engineer (BEE)	1		
Patient Affairs	3		
Dental	1		
Nursing Services	8		
Mental Health	4		
Outpatient Records	2		
Medical Record Storage			
Conference & Meeting			See Chapter 1
Training & Testing			See Chapter 1
Dental Records	1		
PPE Training Bag Storage			
Subtotal		3,659	Net SF
10% Overhead		366	
Subtotal		4,025	
Functional Standard		4,000	Gross SF

6.8.5 Combat Readiness Training Center

Table 6-52: CATCODE 171-450, Med Training CRTC (Full-Time)

Major Functions & Breakouts	Authorized Staffing	Target Area (SF)	Remarks
Aeromedical Physician	1		
Training & Testing			See Chapter 1
Conference & Meeting			See Chapter 1
Health Services Administrator	1		
Public Health	1		
Bio-Environmental Engineer (BEE)	1		
Bio-Environmental Engineering Laboratory			
Laboratory Area			
EKG Room			
Audio Booth Testing			
Dental Exam / X-Ray			
Optometry			
Medical Record Storage			
Dental Records			
Waiting Area			
Subtotal		2,488	Net SF
10% Overhead		249	
Subtotal		2,737	
Functional Standard		2,700	Gross SF

Table 6-53: CATCODE 171-450, Med Training, Visiting Unit

Major Functions & Breakouts	Authorized Staffing	Target Area (SF)	Remarks
Clinic Administration	6		
Patient Records			
Physician's Office (4)	4		
Examination Rooms (3)			
Treatment Room			
Bio-Environmental	1		
Medical Storage / Pharmacy			
Medical Material	3		
Sterile Supply			
Dental Officer			
Dental Administration / Records			
Dirty Linen Storage			
Conference & Meeting			See Chapter 1
Training & Testing			See Chapter 1
Subtotal		2,506	Net SF
25% Overhead		627	
Subtotal		3,133	
Functional Standard		3,100	Gross SF

Table 6-54: CATCODE 171-450, Med Training CRTC Total

Function	Functional Standard (Gross SF)
CRTC Medical Admin	2,700
Visiting Unit Medical	3,100
Medical CRTC Total	5,800

1 6.8.6 Expeditionary Medical Support-Consequence Management (EMEDS-CM) formerly known
 2 as *Chemical, Radiological / Nuclear & Explosive Enhanced Response Force Package and*
 3 *Homeland Response Force (CERFP and HRF)*. The EMEDS-CM medical administration
 4 and training facilities provides space for the commander and support staff, training areas and
 5 support functions.

6 **Table 6-55: CATCODE 171-450, EMEDS-CM Admin / Trng, 47 Personnel**

Major Functions & Breakouts	Authorized Staffing	Target Area (SF)	Remarks
Command & Administration	3	1,030	Net SF
Commander	1		
Medical Readiness Planner	1		Includes medical records area
Health Services Administrator	1		
Training & Testing			See Chapter 1
Conference and Meeting			See Chapter 1
Operations & Training	44	2,348	Net SF
MSC / Medical Logistics	2		
Search & Extraction (PHA, Immunization & Trng)	8		
Triage (Physician Assistants/EMTs)	4		
Emergency Services Physician	1		
Family Physician	1		
Emergency / Trauma Nurse	1		
Nurses	5		
Physician Assistants	3		
Pharmacist	1		
Emergency Medical Technicians	10		
Internist	1		
Cardiopulmonary Lab Craftsman	1		Includes lab workspace
Exam Room (for occupational screenings)			
Bioenvironmental Engineer	1		
Preventive Medicine Physician	1		
Public Health Officer	1		
Bioenvironmental Technician	1		
Public Health Technician	1		
Biomedical Equipment Repair	1		
METI / Pedia SIM			
Support		360	Net SF
Library / Pubs			
Training / Equipment Storage			
Media Center			
Break Area			
Subtotal		3,738	Net SF
25% Overhead		935	
Subtotal		4,673	
Functional Standard		4,700	Gross SF

7 NOTES:

- 8 1. This functional standard is part of the EMEDS-CM mission set and should be adjacent to [EMEDS-CM Medical](#)
 9 [Equipment Storage, CATCODE 442-758](#), (3,400 Gross SF) wherever possible.
 10 2. A collocated facility will require changing the overhead factor to 10% and the functional standard reduced to
 11 4,100 Gross SF.
 12
 13

1 **6.9 CATCODE 171-471, Range Control House (RCH)**

2 This facility is designated for operations, maintenance, workshop, storage of tools, equipment, and
3 miscellaneous supplies as related to an aircraft range ([CATCODE 179-481, Aircraft Range](#)).

4 **Table 6-56: CATCODE 171-471, Range Control House (RCH)**

Authorized Staffing	Functional Standard (Gross SF)
4 – 15	3,900
16 – 35	4,700

5 **6.10 CATCODE 171-472, Range Supply and Equipment Storage**

6 6.10.1 This function provides secure storage space for miscellaneous supplies, tools and equipment
7 used to support small arms ranges and aircraft ranges.

8 6.10.2 The Functional Standard for small arms ranges is **500 Gross SF** covered storage.

9 6.10.3 The Functional Standard for aircraft ranges is **3,200 Gross SF** covered storage.

10
11 **6.11 CATCODE 171-473, Range Target Storage and Repair**

12 Ranges require a **4,800 Gross SF** heated facility for the fabrication, assembly, repair, and
13 maintenance of targets as related to an aircraft range ([CATCODE 179-481, Aircraft Range](#)).

1 **6.12 CATCODE 171-475, Range, Small Arms, Indoor**

2 6.12.1 CATCODE 171-475 will not be applied to equipment funded modular ranges. The
3 equipment funded modular range has strict guidance as relocatable facilities in AFI 32-
4 1021.

5 6.12.2 New construction facilities and subsequent projects under CATCODE 171-475 must comply
6 with the current UFC for Small Arms Ranges.

7 6.12.3 CATCODE 171-475 Unit of measure is Square Feet. The standard facility scope for a
8 normal-use, 7-lane small arms range is 5,800 Gross Square Feet (GSF). NGB/A4S has
9 determined that a 5 to 10-lane small arms range is necessary to meet the annual qualification
10 needs of a standard ANG installation of 900 to 1,200 personnel. This is based on a
11 throughput of roughly one-third of the installation's personnel qualifying annually, with the
12 range being utilized on Guard Drill Weekends and some weekdays. The 7-lane
13 configuration is the most efficient for instructor-to-student ratio. If a shooting range with
14 more than the standard 7 lanes is needed, a two-step approval process is required. First,
15 NGB/A4S must provide written agreement based on documented student throughput.
16 Following that, final approval of a range more than 7 lanes will be by NGB/A4F.

17 **Table 6-57: CATCODE 171-475, Range, Small Arms, Indoor 7, 10, and 14 Firing Lanes scope**

Firing Lanes	SF	SM
7	5,800	539
10	8,000	743
14	10,500	976

1

Figure 6-1: CATCODE 171-475, Indoor Small Arms Range 7 Lane Template

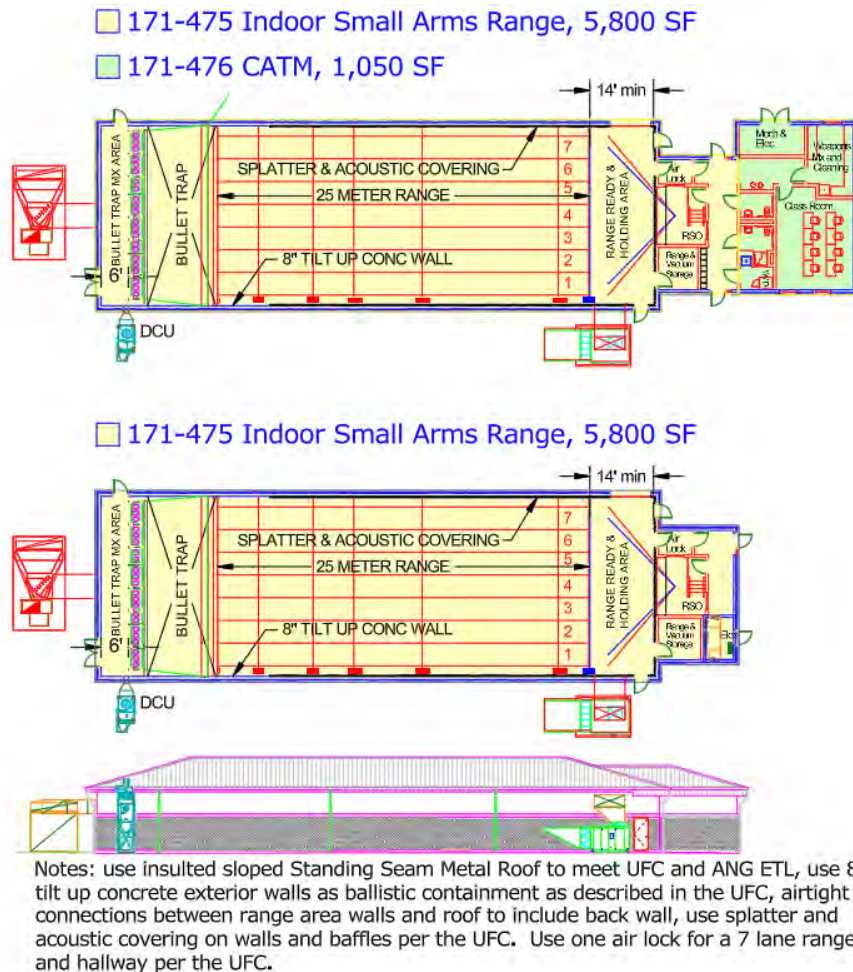

2

3 6.12.4 The indoor range follows the same strategy of a partially contained outdoor range
4 [CATCODE 179-475, Small Arms Range, Outdoor](#) that in some situations partnering with a
5 local range or centralizing a DoD range use might be a better fit than continued use of an on
6 base range or the construction of a new on base indoor range.

7 6.12.5 If constructing a new indoor small arms range will need a community involvement plan to
8 gain collaboration on the use of existing local community ranges or other agencies ranges if
9 available as the preferred option. Also, need the community involvement plan for possible
10 cost sharing when outside agencies use an ANG small arms range if the only remaining
11 option is a new indoor range to accomplish small arms training.

12 6.12.6 An indoor range consists of 25-meter rifle and pistol range with 5' wide firing lanes. Indoor
13 ranges have open bays with shooting generally straight downrange into a bullet trap.
14 Ballistic containment is provided by ballistic side walls, overhead baffles, and bullet trap. A
15 push-pull ventilation system supplies air from behind the firing line and exhausts at the trap
16 end to move airborne contaminants downrange and away from personnel inside the range,
17 exhaust is more powerful to maintain negative air pressure in the range. Incorporate a
18 Direct Digital Control (DDC) system to initiate supply and exhaust fans at low speeds that
19 ramp up to field adjustable levels as necessary to reach desired negative pressure inside the
20 range. A ventilation control panel (see Figure 6-3) located in the range control booth with
21 diagnostic screen, an on/off switch, and three condition lights on the panels: Safe to Shoot,

Warning, and Do Not Shoot. Space is provided for bullet catch maintenance area, bullet catch, firing lanes, range holding/ready area (14 ft. full length clear distance depth behind the firing line), range control booth (raise floor in control booth a minimum 2 ft. above the range floor to promote visibility), air lock vestibules, hallway space, storage areas immediately off the training area for vacuum storage and some minor range equipment storage. Related classroom, weapons maintenance, weapons cleaning, and minimal latrine/shower/lockers to meet the UFC are captured under [CATCODE 171-476, Combat Arms Training Maintenance \(CATM\)](#), see layouts. Typically built with CATM (see [Figure 6-4](#)).

6.12.7 Adhere to UFC 4-179-02, Small Arms Ranges, guidance for air testing, noise testing, and complete Acceptance Tests.

Figure 6-2: CATCODE 171-475, Indoor Small Arms Range elevated control booth and firing line



Figure 6-3: CATCODE 171-475, Indoor Small Arms Range showing ventilation control panel in control booth



6.13 CATCODE 171-476, Combat Arms Training Maintenance (CATM)

6.13.1 Used in conjunction with [CATCODE 179-475, Small Arms Range, Outdoor](#) , or [CATCODE 171-475, Range, Small Arms, Indoor](#). The CATM function provides space for classroom instruction, weapons maintenance/cleaning, laundry (for range laundry use only), and minimal latrine/shower/locker are to meet the UFC 4-179-02 Small Arms Ranges, guidance for design of all new small arms range/Combat Arms support facility projects.

Table 6-58: CATCODE 171-476, Combat Arms Training Maintenance

Major Functions & Breakouts	CATM for 10 or 14 lane range (SF)	CATM for 7 lane range (SF)	Remarks
Classroom / Break Area			
Washer and Dryer			
Weapons Cleaning / Degreasing			
Latrine/Shower			
Subtotal	1,080	840	Net SF
25% Overhead	270	210	
Subtotal	1,350	1,050	
Functional Standard	1,350	1,050	Gross SF

Figure 6-4: CATCODE 171-476, CATM Template

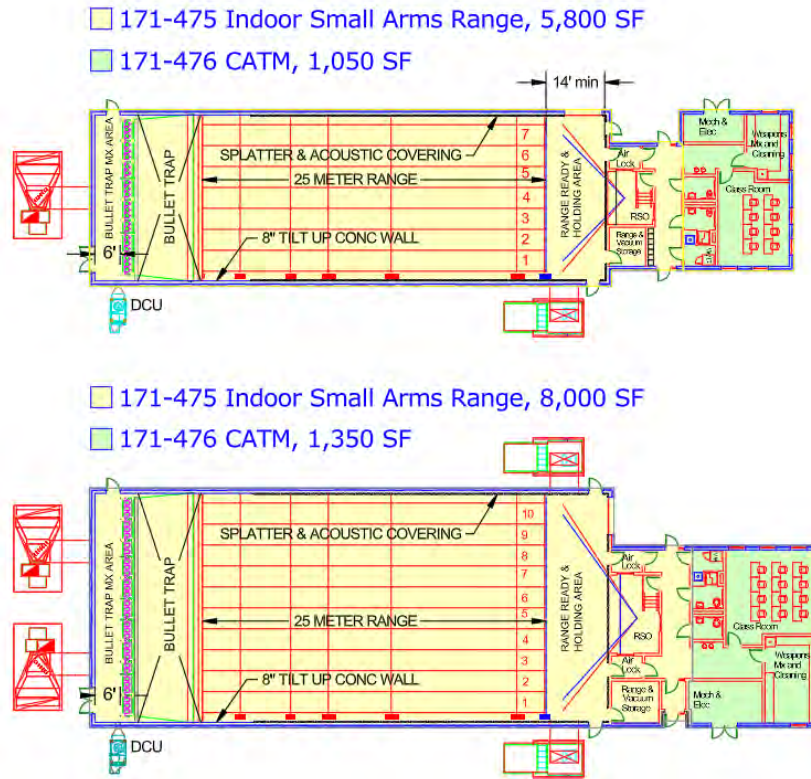

6.14 **CATCODE 171-618, Field Training Facility**

6.14.1 RPA Field Training Detachment (FTD): An AETC detachment established to provide maintenance-oriented technical training on RPAs and associated aerospace ground equipment at an operational location. An FTD may be located at a base on a temporary or permanent basis. RPA FTDs will have a full Mobile Training Set (MTS) consisting of two completely assemble RPA aircraft trainers, two full sets of training aids, and operational equipment designed for use in the field primarily to support maintenance training.

Table 6-59: CATCODE 171-618, RPA Field Training Detachment

Major Functions & Breakouts	Authorized Staffing	Target Area (SF)	Remarks
Administration & Classrooms	15	3,971	Net SF
Superintendent	1		
Production Controller	1		
Admin	1		
Instructors	12		
Standard Classroom			5 @ 400 SF per MQ-9 facility standard guidance
Specialized Classroom			1 @ 595 SF per MQ-9 facility standard guidance
Student Hotel Stations			
High-Bay Classrooms		10,800	Net SF
High-Bay Classroom (20 ft ceiling)			100' x 45'
High-Bay Classroom (20 ft ceiling)			100' x 60'
Ops GCS Trainer			
Support		100	Net SF
Break Area			
Subtotal		14,871	Net SF
10% Overhead		3,718	
Subtotal		18,589	
Functional Standard		18,600	Gross SF

NOTE: The RPA Field Training Detachment (FTD) is also authorized: [CATCODE 442-759, Base Supply & Equipment Warehouse](#) – 9,700 SF (Table 9-3)

6.14.2 RPA Mission Control Element (MCE) FTD: RPA MCE locations operating under the 1 steady state + 1 surge + maintenance construct are authorized space to provide training for their deployable maintenance and munitions UTCs. The RPA MCE Field Training Detachment (FTD) will have one fully assembled MQ-9 aircraft and will typically have 55 maintenance and 9 munitions personnel. Administrative space for this function is provided under CATCODE 610-129, Weapon Systems Maintenance Management.

1

Table 6-60: CATCODE 171-618, RPA Mission Control Element (MCE) FTD

Major Functions & Breakouts	Authorized Staffing	Target Area (SF)	Remarks
Classrooms		995	Net SF
Standard Classroom			
Specialized Classroom			
High-Bay Classrooms		4,800	Net SF
High-Bay Classroom (20 ft ceiling)			100' x 45' per MQ-9 facility standard guidance
Ops GCS Trainer			15' x 20' per MQ-9 facility standard guidance
Support		100	Net SF
Break Area			
Subtotal		5,895	Net SF
10% Overhead		1,474	
Subtotal		7,369	
Functional Standard		7,400	Gross SF

2

3

NOTE:

4

1. The following additional functional standards are also part of the RPA MCE Maintenance mission set:

5

a. [CATCODE 610-129, Weapon Systems Maintenance Management \(WSMM\)](#) – IAW Table 10-19 (2,500 SF)

6

b. CATCODE 216-642, Conventional Munitions Maintenance – 2,900 SF

7

c. CATCODE 442-758, Base Supply & Equipment Warehouse – 2,000 SF

8

1 6.14.3 Field Training Facility, Battlefield Airmen Gym, at all ANG Air Support Operations
2 Squadrons (ASOS) and Guardian Angel Locations. With the Physical Fitness Tests and
3 Standards all ASOS and Guardian Angel units will need adequate facilities to support each
4 individual’s Battlefield Airmen Physical Fitness Test (BAPFT) and the conditioning in
5 preparation for the BAPFT.

6 **Table 6-61: CATCODE 171-618, Field Training Facility, Battlefield Airmen Gym**

Major Functions & Breakouts	Authorized Staffing	Target Area (SF)	Remarks
ASOS Gym		3,650	Net SF
Medicine Ball Toss/Three Cone Drill/Farmer’s Carry/Extended Cross Knee Crunch		1,400	
Trap Bar Deadlift		800	
Pull-Up/Lunges, weighted 50 lb		625	
Row Ergometer, 1000 meters		300	
Run, 1.5 miles (indoor cardio equipment)		525	
Support	3	248	100’ x 45’ per MQ-9 facility standard guidance
Physical Therapist	1	120	
Athletic Trainer	1	64	
Performance Coach	1	64	
Subtotal		3,898	Net SF
10% Overhead		390	
Subtotal		4,288	
Functional Standard	3	4,300	Gross SF

7

8 **Figure 6-5: CATCODE 171-618, Field Training Facility, Battlefield Airmen Gym, ASOS**

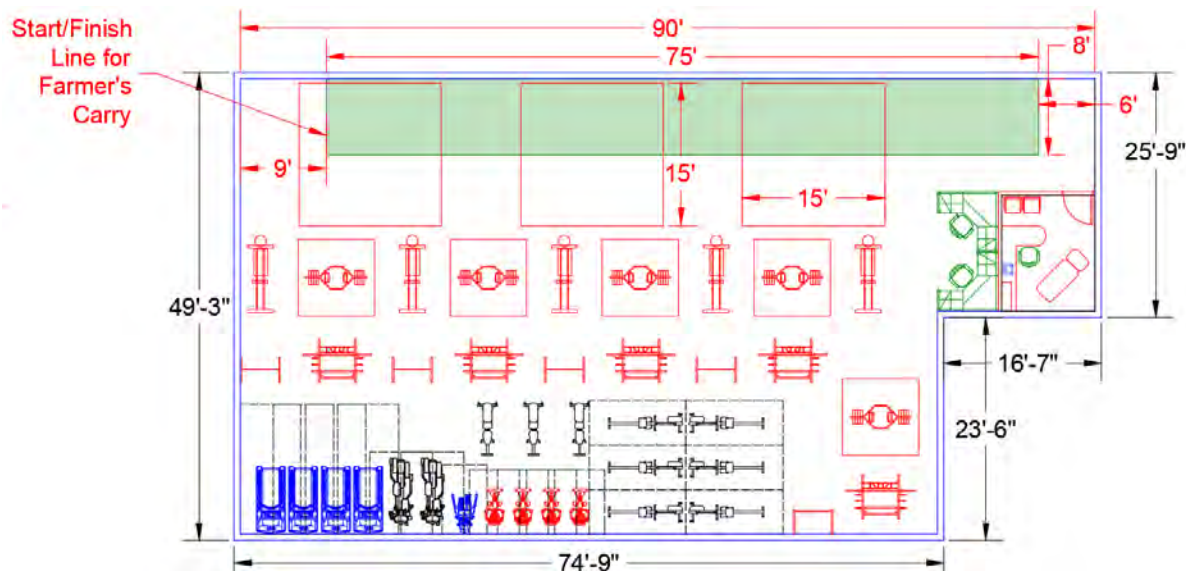

9

6.15 CATCODE 171-875, Munitions Loading Crew Training Facility

Provides a separate-use space or facility at fighter bases for A-10, F-15, F-16, F-22, and F-35 aircraft ‘hands-on’ and classroom training of weapons loading personnel. The facility must have fire suppression, and proper heating and ventilation. The facility is normally attached to a [CATCODE 215-552, Weapons and Release Systems Shop](#).

Table 6-62: CATCODE 171-875, Munitions Loading Crew Training

Major Functions & Breakouts	Authorized Staffing	Target Area (SF)	Remarks
Aircraft Load Certification Bay		6,500	
Support	4	676	
Classroom			Sized for 20 personnel
Loading Standardization Certification Office (LSC)			
Load Standardization NCOIC	1		
Load Standardization Crew	3		
Subtotal		7,176	Net SF
10% Overhead		718	
Subtotal		7,894	
Functional Standard		7,900	Gross SF

NOTE:

- Function is intended to be collocated with [Weapons and Release Systems Shop \(CATCODE 215-552\)](#). Increase Functional Standard to 8,300 Gross SF if a Stand-Alone Facility.

1 **6.16 CATCODE 179-371, Miscellaneous Training**

2 6.16.1 Referenced in Appendix A, the standard for this function is one each. The following
3 definitions are provided in Appendix C:

4 6.16.1.1 Airfield Pavements / Airfield Damage Repair (ADR) Site.

5 6.16.1.2 Pad for Priority Improved Management Effort – Readiness in Base Services (Prime
6 RIBS) Mobile Kitchen Trailer (MKT) or Containerized Deployment Kitchen (CDK)
7 with utilities.

8 6.16.1.3 Training Aid that is part of a Regional Training Site (RTS).

9 6.16.1.4 Minimum of 100 ft. x 1,000 ft., 9 inch thick concrete authorized for Airfield Damage
10 Repair (ADR), Aircraft Arresting System (MAAS) and fiberglass mat training.

11 6.16.2 Lightning Force Academy (LFA) Communications Training Aid (CTA): 1 each at 500 SF
12 for a concrete pad and communications vault for the CTA at the LFA located at Fort
13 Indiantown Gap ANG Station, PA.

6.17 CATCODE 179-475, Small Arms Range, Outdoor

6.17.1 Facility designed to provide outdoor small arms training with Unit Of Measure as FP for Firing Position. Below is the AF CATCODE published image.

Figure 6-6: CATCODE 179-475, Small Arms Range, Outdoor



6.17.2 For indoor small arms range see ([CATCODE 171-475, Range, Small Arms, Indoor](#))

6.17.3 Access to a Small Arms Range is required to conduct initial firearms qualification and proficiency training with individual firearms. In some situations partnering with a local range or centralizing a DoD range use might be a better fit than continued use of an on base range – under DoD directive Small Arms Range initiative/repair drive a cost analysis which is required to retain this capability in-house.

6.17.1.1 Partially contained outdoor ranges can be used and repaired as long as the planned range repair or component repairs cost is less than 50 percent of the estimated range replacement cost (plant replacement value), if cost is over 50% of the PRV then the entire facility must be upgraded to either be a fully contained indoor range or a non-contained range.

6.17.1.2 NGB/A4S has agreed to 10 firing positions for a Small Arms Range. If a unit has a fully functional 21-point range they can keep it.

6.17.1.3 Reference AFMAN 36-2655 range requirements. Range with 25-meter/yard target line capable of accommodating the type of ammunition used for training.

6.17.1.4 Since year 2000 any 300 yd SDZ can still be used firing frangible only and can continue to be used by possibly doing minor repairs like adding more baffles for the new firing while moving portion and different distances of the new weapons qualifications as long as the added baffles or repairs are less than 50% of the PRV.

6.17.4 Various other functions (i.e., a latrine, supplies and equipment storage, target storage and repair, CATM, CATS, etc.) may also be included as part of a small arms range complex.

6.17.4.1 The range supplies and equipment storage facility ([CATCODE 171-472, Range Supply and Equipment Storage](#)) provides secure storage space for miscellaneous range supplies, tools, and equipment. Use a prefabricated metal, reinforced concrete, reinforced masonry, or wooden building. Depending on location, type, and value of items stored, this facility may be combined with the range target storage and repair building.

1 6.17.4.2 The range target storage and repair facility ([CATCODE 171-473, Range Target](#)
2 [Storage and Repair](#)) provides **400 Gross SF** for repairing and storing targets, target
3 mechanisms, and target construction and repair materials. Repair space contains
4 tables and workbenches. Provide an electrical power source for operating power
5 tools. Use a prefabricated metal, reinforced concrete, reinforced masonry, or wooden
6 building. Depending on location, type, and value of items stored, this facility may be
7 combined with the range supplies and equipment building.

8 6.17.4.3 Review the SDZ and VDZ boundaries IAW AFI36-2654, 16 APRIL 2020, for any
9 outdoor range.

10

1 6.18 **CATCODE 179-481, Aircraft Range**

2 6.18.1 Ranges are required to provide training in bombing, firing rockets and missiles, and the use
3 of automatic weapons. Types of ranges include air-to-ground and ground-to-air.

4 6.18.2 The range must be a vacant area that can be used without endangering life or property. Area
5 improvements normally required before use as a range are control facilities for scoring
6 targets, minimum access facilities, and temporary communications facilities. See Appendix
7 A for the authorized areas associated with aircraft ranges.

8

6.19 CATCODE 179-511, Fire Fighter Training Facility

- 6.19.1 For Combat Readiness Training Center (CRTC) and ANG Regional Training Site (RTS) locations Fire Fighter Training Facility: The facility supports the recurrent proficiency training of fire suppression personnel permitting realistic live training fires in structures, aircraft, and selected weapons systems.
- 6.19.2 The complex consists of an aircraft mock up area; gas storage tanks; a control building; a water conservation pond; maneuvering pavements and/or gravel; a structural fire trainer; related infrastructure (such as underground gas & water lines, dedicated electrical panel, etc.); and related storage needs. O&M is not centrally managed thus each location should budget for upkeep with local funds. Major repairs will need coordination with NGB/A4OE. The complex must comply with T.O.35E1-2-1-13-1 and NFPA standard for fire training facilities. Structural trainers must comply with NFPA 1403.
 - 6.19.2.1 Facility requires a mockup of a typical mission assigned aircraft located in a bermed enclosure commensurate with the typical aircraft fuel load. A stabilized area around the spill area is required to permit all weather multidirectional access, including drive-around capability by the largest assigned vehicle. A Standardized Design, Crash Fire Rescue Training Facility-3P (propane fueled) is available from AFCEC/CEO in *TO 35E1-2-13-1*.
 - 6.19.2.2 Mockup and spill area for three dimensional fires is required.
 - 6.19.2.3 A non-combustible facility is needed for structural fire training. This facility should be multiple stories, three to four stories preferred, with multiple height roofs.
 - 6.19.2.4 A drafting pit and fire hydrant should be included as well as a fuel dispensing system connected to a storage tank and servicing connection. Liquid propane is the primary fuel.
 - 6.19.2.5 Adequate pollution control devices required to meet local, state, and federal requirements and other guidance should be in place including, but not limited to, double lined fire training facility and closed loop, no discharge facility.
- 6.19.3 New, renovated, or expanded facilities must be sited according to ETL 91-4, Site Selection Criteria for Fire Protection Training Areas. Locate facilities to comply with explosives safety standards.

Table 6-63: CATCODE 179-511, Fire Fighter Training Facility, Summary

Major Functions & Breakouts	Target Area (SF)	Remarks
Mock Aircraft	one each	
Control Tower	one each	Typical is 400 SF
Gas Tank(s)	one each	
Structural Fire Trainer	one each	Typical is 2,300 SF
Water Conservation Pond	one each	
Storage	640	
Class Room	800	

Chapter 7: Category Group 21 – Maintenance Facilities

7.1 General Criteria

- 7.1.1 Hangar maintenance docks are protected space for the maintenance of the aircraft based on flying mission groups with published details in the Air National Guard Mission Grouped Hangar Sizes (<https://www.wbdg.org/ffc/ang/handbooks-angh/mission-grouped-aircraft-hangar-sizes>) which establishes large (211-173), medium (211-175), and small (211-177) maintenance dock to replace CATCODE 211-111. Hangar maintenance docks provide space for scheduled inspections, landing gear retraction tests, the weighing of aircraft, airframe repairs, and ensuring Technical Order (T.O.) compliance. All facilities must be located in accordance with DESR 6055.09_AFMAN91-201 explosives safety standards.
- 7.1.2 The ANG assigns square footage based on the weapon system. Evaluation of the weapon systems can assign a Mission Grouped hangar size for a group of aircraft in keeping Refuelers together, C-130s together, and fighters together.
- 7.1.3 Hangar restrooms are accounted for in the notes for the hangar space. Mission Grouped Hangar Bay square footages is only for the hangar bay, 16” hangar bay wall thickness, 19” hangar door thickness, area for interior support columns only when a conflict with the aircraft setback bubble cannot be avoided, and any area taken by the pocket doors. See below Summary Table for weapon system to Mission Grouped Maintenance Hangar Bay sizes.

Table 7-1: Air National Guard Mission Grouped Maintenance Hangar Sizes Summary

Aircraft / Mission	Covered Spaces	CATCODE	Size	Bay (Gross SF)
C-17, KC-46, KC-135 ¹	1	211-173	Large	36,500
F-15, F-16, F-22, F-35 (Single Door Hangar)	6			
F-15, F-16, F-22, F-35 ²	6	211-175	Medium	30,000
C-130 / C-130J-30 Stretched	1	211-177	Small	20,000
CRTC	1			
Predator - MQ-1 (published 16 Nov 2007)	6			
Reaper - MQ-9 (published 16 Nov 2007)	4			

1. Must fit C-17 with square footage and elevation

2. Other aircraft configurations will fit into smaller size bay and should be considered to achieve best alternative meeting needs of the ANG

Figure 7-1: WBDG ([Link](#)) to published ANG Mission Grouped Hangar Sizes



1 **Figure 7-2: Typical Mx Hangar Bathroom**

2
3 **Typical Mx Hangar
Bathroom 1,684 SF**

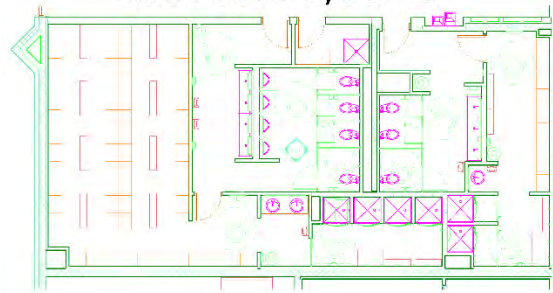

4 **7.2 CATCODE 211-173, Large Aircraft Maintenance Dock**

5 211-173, Large Aircraft Maintenance Dock includes the C-17, KC-135 and KC-46 and 6 universal
6 fighters (universal fighter is based on the F-22 width and F-15 length) in a traditional single door
7 hangar.

8 7.2.1 Considering a traditional single door hangar provides 35,216 SF and will fit six universal
9 fighters while allowing each to have a path for direct exit. The six fighter layouts account
10 for the hangar bay wall thickness, hangar door, and door pockets.

11 **Figure 7-3: Six Mission Grouped Fighter with Single Door Hangar Bay Size**

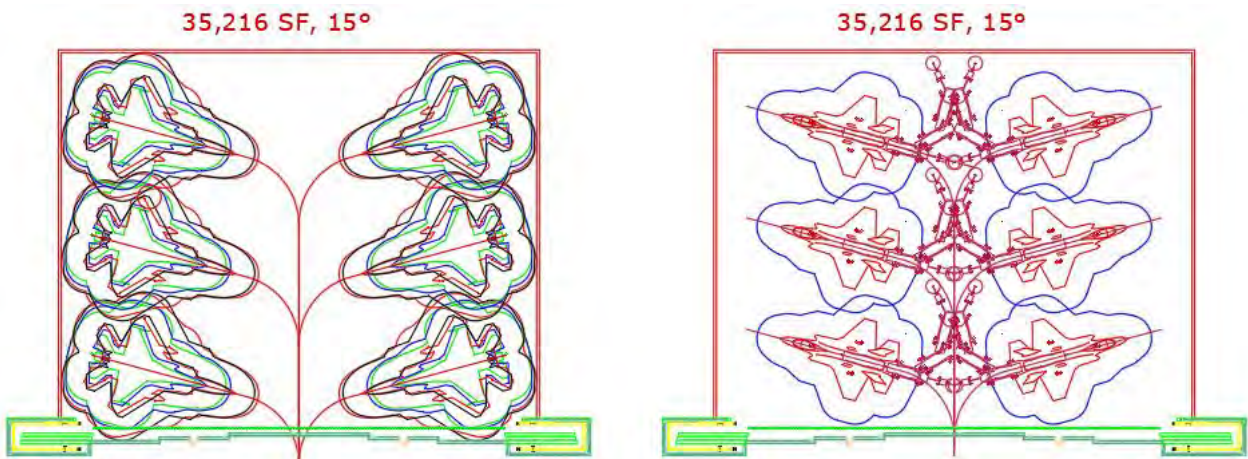

12 7.2.2 The ANG assigns square footage based on the weapon system. Evaluation of the weapon
13 systems can assign a Mission Grouped hangar size for a group of aircraft in keeping
14 Refuelers together, C-130s together, and fighters together.

Table 7-2: 211-173, Large Aircraft Maintenance Dock Summary

Aircraft / Mission	Covered Spaces	Functional Standard (Gross SF)
C-17, KC-46, KC-135 ¹	1	36,500
F-15, F-16, F-22, F-35 (Single Door Hangar) ²	6	36,500

- 1 *1. The associated mechanical room will be constructed external to the hangar bay, ensuring no reduction of the bay's square footage.*
- 2 *The bathroom and mechanical room's area shall not exceed 3,000 square feet.*
- 3 *2. Must fit C-17 with square footage and elevation.*
- 4 *3. Other aircraft configurations will fit into smaller size bay and should be considered to achieve best alternative meeting needs of*
- 5 *the ANG (see Chapters 2 & 3 for details).*

6

Figure 7-4: Airlift/Tanker Large Mx Hangar Bay proof of concept and an existing project.

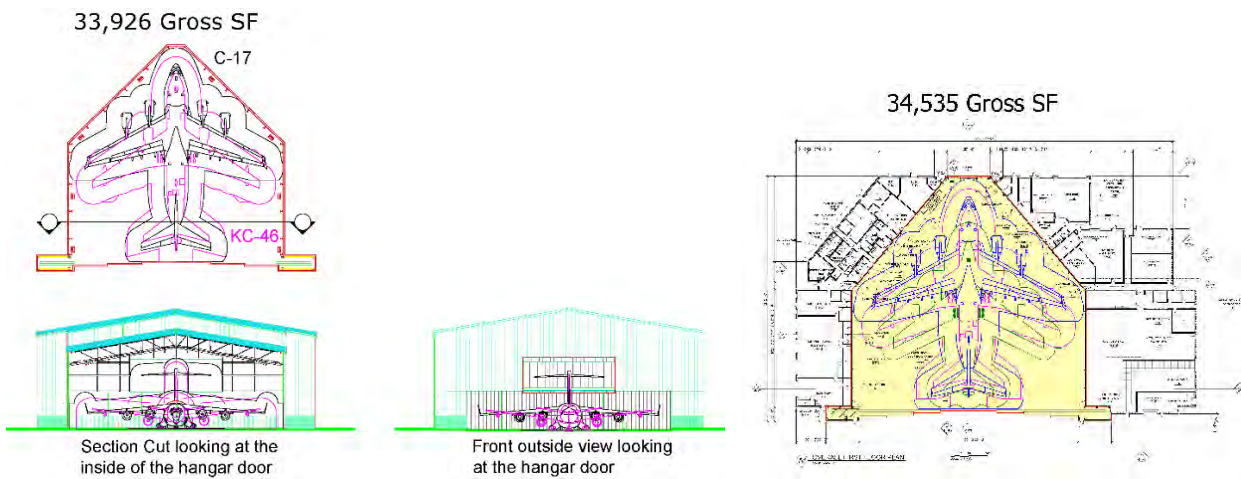

8

7.3 CATCODE 211-175, Medium Aircraft Maintenance Dock for Fighters

7.3.1 The universal fighter is based on the F-22 width and F-15 length, which are the controlling (largest) dimensions in the ANG Fighter Enterprise. Six (6) mission-grouped fighters will utilize CATCODE 211-175, Medium Aircraft Maintenance Dock, with authorization 30,000 SF for a double door hangar.

7.3.2 A double-door hangar can accommodate six (6) universal fighters, each with its own direct exit path within this authorization. The layout depicted in Figure 2-1 accounts for the hangar bay wall thickness, hangar door, and door pockets.

Table 7-3: CATCODE 211-175, Medium Aircraft Maintenance Dock Aircraft¹

Aircraft / Mission	Covered Spaces	Functional Standard (Gross SF)
F-15, F-16, F-22, F-35 (Double Door or inline)	6	30,000

1. The associated mechanical room will be constructed external to the hangar bay, ensuring no reduction of the bay's square footage. The bathroom and mechanical room's area shall not exceed 3,000 square feet.
2. Recognizing aircraft configurations will fit into smaller size bay and should be considered to achieve best alternative meeting needs of the ANG.

Figure 7-5: CATCODE 211-175, Medium Mx Hangar Bay Layouts

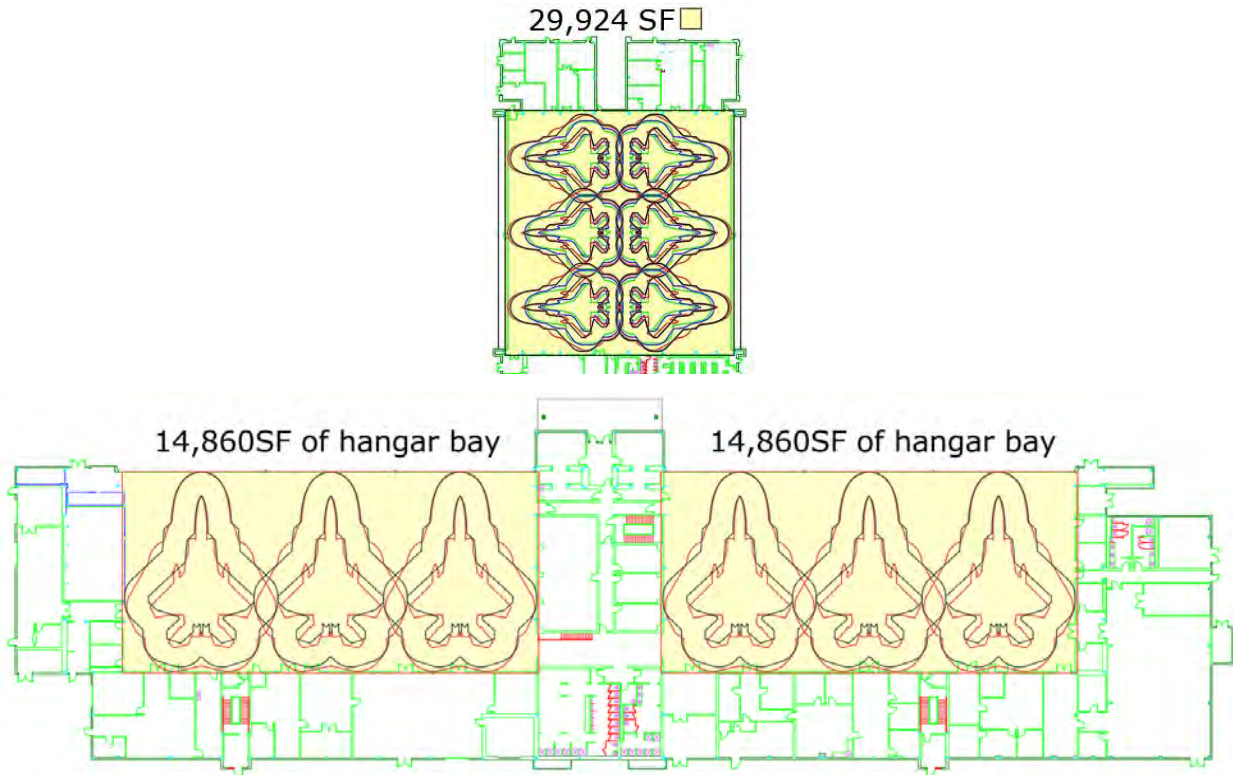

7.4 CATCODE 211-177, Small Aircraft Maintenance Dock, C-130J-30 and smaller aircraft

7.4.1 This Category Group is for all other flying missions C-130J-30 Stretched and smaller.

Table 7-3: CATCODE 211-177, Small Aircraft Maintenance Dock Aircraft¹

Aircraft / Mission	Covered Spaces	CATCODE	Size	Bay (Gross SF)
C-130 / C-130J-30 Stretched	1	211-177	Small	20,000
CRTC	1	211-177	Small	20,000
HH-60G	2	211-177	Small	20,000
Predator - MQ-1	6	211-177	Small	20,000
Reaper - MQ-9	4	211-177	Small	20,000

1. The associated mechanical room will be constructed external to the hangar bay, ensuring no reduction of the bay's square footage. The bathroom and mechanical room's area shall not exceed 3,000 square feet.

Figure 7-6: C-130 and C-130J-30 Stretched Maintenance Hangar Size

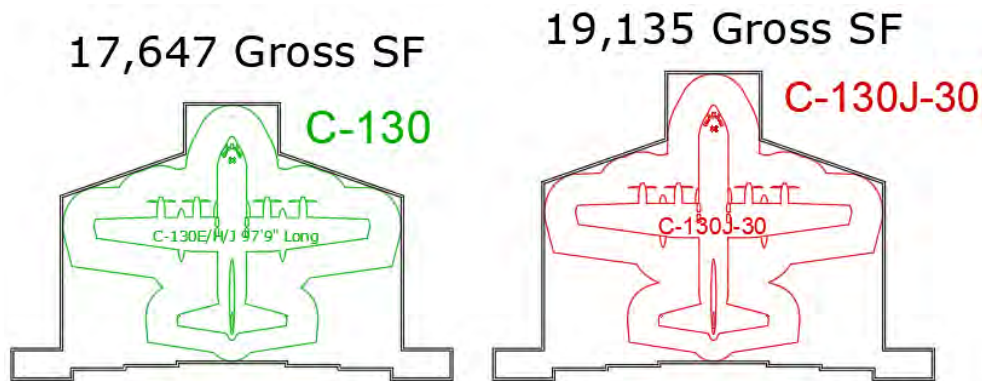
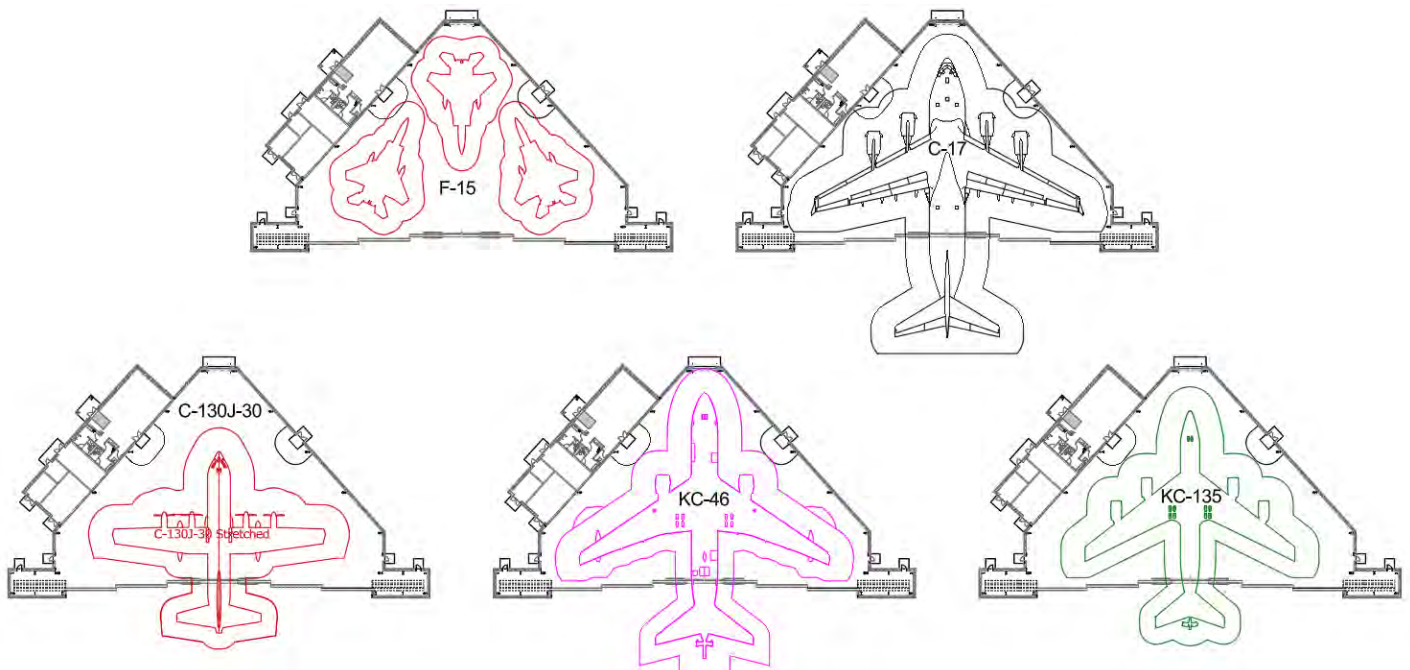
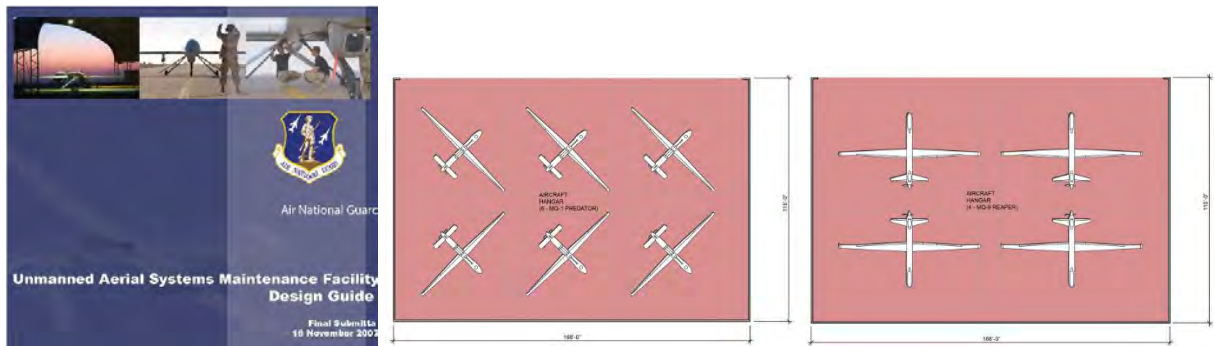

Figure 7-7: CRTC Maintenance Hangar



1

Figure 7-8: MQ-1 and MQ-9, UAV Maintenance Final Design Guide



2

3

7.5 **CATCODE 211-152, Aircraft General Purpose Shops**

Provides space for specialized maintenance activities such as fabrication / sheet metal shop, egress shop, machine shop, welding shop, wheel and tire shop, environmental shop, electrical systems shop, pneumatic / hydraulic shop, battery shop, and composite shop. The facility also includes space for work, administration, classrooms, tool cribs, bench stock, latrines, lockers, storage, security supplies, and repairable parts.

Table 7-4: CATCODE 211-152, Aircraft General Purpose Shops Details

Major Functions & Breakouts	Target Area (SF)				
	F-15, F-15EX, F-16,	F-35, F-22	C-130H/J, KC-135	C-17	KC-46A
Wheel & Tire Shop/RR/CDDAR					See Note 1
Tool Crib & Metal Storage					
Egress					
Electro/Environmental Shop					
Metals Tech Shop					
ASM/LOASM Shop					
Pneudralic/hydraulics Shop					
Battery Shop					
ISO Phase/A-Check					See Note 2
Training & Testing					
CTK Storage					
Break Area					
Subtotal	14,150	11,050	16,850	17,350	29,150
15% Overhead	2,123	1,658	2,528	2,603	4,373
Subtotal	16,273	12,708	19,378	19,953	33,523
Functional Standard	16,300	12,700	19,400	20,000	33,500

NOTE:

1. Add 1,000 SF for R&R and CDDAR if not stored in the hangar bay
2. Add 1,000 Admin Space for A-Check if not in the hangar bay
3. Composites square footage moved to 211-159 to match past KC-46 approval and AF Reserves.

Table 7-5: CATCODE 211-152, Aircraft General Purpose Shops, RPA

Major Functions & Breakouts	RPA	Remarks
Structural Maintenance		
Machine/Metal Shop		
Weld Shop		
FG/Composite Shop		
Tool Crib & Metal Storage		
Bathroom		
Break area		
Subtotal	4,500	Net SF
15% Overhead	675	
Subtotal	5,175	
Functional Standard	5,200	Gross SF

1

Table 7-6: CATCODE 211-152, Aircraft General Purpose Shops Summary

Aircraft / Mission	Functional Standard (Gross SF)	Remarks
A-10 / F-15 / F-15EX / F-16	16,300	1 to 24 PAA
F-35/F-22	12,700	1 to 24 PAA
C-17	20,000	1 to 8 PAA
C-130H / J	19,400	1 to 12 PAA
KC-135	19,400	1 to 12 PAA
KC-46	33,500	1 to 12 PAA
RPA mission with hangar and no Maintenance Squadron	500	1 to 18 PAA
RPA LRE with Maintenance Squadron	5,200	1 to 18 PAA
MC-12	12,200	1 to 18 PAA
CRTC	4,000	Visiting Unit

2

3

7.6 CATCODE 211-153, Non-Destructive Inspection Shop

7.6.1 Provides space for field-level, non-destructive inspection of aircraft components, a process that investigates the quality, integrity, properties, and dimensions of materials and components without damaging or impairing their serviceability through the use of optic, magnetic, eddy-current, ultrasonic, radiographic, infrared, ultraviolet, and spectrometric devices.

7.6.2 Inspection spaces include a joint oil-analysis program (JOAP) lab, X-ray room, film developing room, tool crib and parts storage, locker space, penetrant storage, magnetic particle lines, and office areas.

Table 7-7: CATCODE 211-153, Non-Destructive Inspection Shop

Aircraft / Mission	Functional Standard (Gross SF)
C-17	4,000
KC-46A	3,000
F-15 / F-15EX / F-16 / F-22 / A-10 / F-35 / RPA / MC-12	2,800
KC-135	2,600
C-130	2,200
CRTC	400

7.7 CATCODE 211-154, Aircraft Organizational Maintenance Shop (AMU)

7.7.1 This function provides space for personnel and mission needs of the Aircraft Maintenance Squadron Operations and Maintenance Squadron Operations while the administration space is under CATCODE 610-129 Weapons Systems Maintenance Management.

Table 7-8: CATCODE 211-154, Aircraft Org Mx Shop, Fighter, 120 Personnel

Major Functions & Breakouts	Authorized Staffing	Fighters	Remarks
Command & Administration	0	1,140	Net SF
Conference & Meeting			
Training & Testing			
Operations	120	3,428	Net SF
Maintenance NCOIC	1		
Maintenance Debrief			
Flight Officers/Chiefs	4		
Superintendent	1		
Maintenance Administration	4		
Tool Room/Bench Stock			
Tail Number Bins			
Tech Order Library			
Ready Room	106		37 Hoteling Stns added
Production Supervisor	4		
Support	0	3,250	Net SF
Break Room			
PPE Training Bag Storage			
Production Scheduling			
Support Equipment Maintenance			
Dash-21 Equipment Storage			
Subtotal		7,818	Net SF
15% Overhead		1,173	
Subtotal		8,991	
Functional Total		9,000	Gross SF

1

Table 7-9: CATCODE 211-154, Aircraft Org MX Shop, KC-135/C-17/C-130, 60 Personnel

Major Functions & Breakouts	Authorized Staffing	Fighters	Remarks
Command & Administration	0	890	Net SF
Conference & Meeting			
Training & Testing			
Operations	60	4,078	Net SF
Maintenance NCOIC	1		
Maintenance Debrief			
Flight Officers/Chiefs	4		
Superintendent	1		
Maintenance Administration	4		
Tool Room/Bench Stock			
Tail Number Bins			
Tech Order Library			
Ready Room	48		24 Hoteling Stns added
Production Supervisor	2		
Support	0	1,700	Net SF
Break Room			
PPE Training Bag Storage			
Production Scheduling			
Support Equipment Maintenance			
Dash-21 Equipment Storage			
Subtotal		6,668	Net SF
15% Overhead		1,000	
Subtotal		7,668	
Functional Total		7,700	Gross SF

2

3

1

Table 7-10: CATCODE 211-154, Aircraft Org MX Shop, KC-46, 90 Personnel

Major Functions & Breakouts	Authorized Staffing	Fighters	Remarks
Command & Administration	0	1,050	Net SF
Conference & Meeting			
Training & Testing			
Operations	90	5,560	Net SF
Maintenance NCOIC	1		
Maintenance Debrief			
Flight Chiefs	4		
Superintendent	1		
Maintenance Administration	30		
Tool Room/Bench Stock			
Tail Number Bins			
Tech Order Library			
Ready Room	52		
Production Supervisor	2		
Support	0	2,135	Net SF
Break Room			
PPE Training Bag Storage			
Production Scheduling			
Support Equipment Maintenance			
Dash-21 Equipment Storage			
Subtotal		8,745	Net SF
15% Overhead		1,312	
Subtotal		10,057	
Functional Total		10,100	Gross SF

2
 3

1

Table 7-11: CATCODE 211-154, Aircraft Org MX Shop, Rescue, 95 Personnel

Major Functions & Breakouts	Authorized Staffing	Fighters	Remarks
Command & Administration	0	1,050	Net SF
Conference & Meeting			
Training & Testing			
Operations	95	4,244	Net SF
Maintenance NCOIC	1		
Maintenance Debrief			
Flight Officers/Chiefs	4		
Superintendent	1		
Maintenance Administration	4		
Tool Room/Bench Stock			
Tail Number Bins			
Tech Order Library			
Ready Room	82		24 Hoteling Stns added
Production Supervisor	3		
Support	0	3,650	Net SF
Break Room			
PPE Training Bag Storage			
Production Scheduling			
Support Equipment Maintenance			
Dash-21 Equipment Storage			
Subtotal		8,944	Net SF
15% Overhead		1,342	
Subtotal		10,266	
Functional Total		10,300	Gross SF

2

3

1
2

Table 7-12: CATCODE 211-154, Aircraft Org Mx, RPA LRE, 40 Personnel

Major Functions & Breakouts	Authorized Staffing	Fighters	Remarks
Command & Administration	0	670	Net SF
Conference & Meeting			
Training & Testing			
Operations	40	2,144	Net SF
Maintenance NCOIC	1		
Maintenance Debrief			
Flight Officers/Chiefs	2		
Superintendent	1		
Maintenance Administration	2		
Tool Room/Bench Stock			
Tech Order Library			
Ready Room	32		16 Hoteling Stns added
Production Supervisor	2		
Support	0	2,150	Net SF
Break Room			
PPE Training Bag Storage			
Production Scheduling			
Support Equipment Maintenance			
Dash-21 Equipment Storage			
Subtotal		4,964	Net SF
15% Overhead		745	
Subtotal		5,709	
Functional Total		5,700	Gross SF

3 NOTE:
4 1. Only required for RPA missions if functions are completed by blue suit maintenance.
5

6 **Table 7-13: CATCODE 211-154, Aircraft Organizational Maintenance Shops Summary**

Aircraft / Mission	Functional Standard (Gross SF)
Fighter	9,000
KC-135, C-17, C-130	7,700
KC-46	10,100
Rescue	10,300
RPA or LRE with blue suit maintenance	5,700
CRTC	4,000

7

7.8 CATCODE 211-157, Jet Engine Inspection and Maintenance Shop

- 7.8.1 Provides space for scheduled inspections, routine maintenance, and operational-level repair of aircraft engines. Major functions performed in the shop include disassembly, inspection, repair, replacement, technical order compliance adjustment, and assembly of engine components.
- 7.8.2 Separate areas for the storage of spare engines, covered storage for engine trailers, a bearing and inspection shop, parts storage and a tool crib, parts cleaning, a propeller shop (if required), and office administration are also provided.
- 7.8.3 Space is authorized for, three-level and two-level maintenance operations; the difference being that three-level maintenance is conducted entirely by the local unit, whereas two-level maintenance requires depot involvement.
- 7.8.4 Additional space not to exceed 1,100 SF is authorized on a case by case basis for a remote facility at the unsuppressed power check pad ([CATCODE 116-664, Unsuppressed Power Check Pad](#)) or the engine test stand ([CATCODE 211-193, Test Stand](#)), which provides a covered facility to perform minor engine adjustments without having to return to the main engine shop.

Table 7-14: CATCODE 211-157, Jet Engine Inspection and Maintenance Shop Details

Major Functions & Breakouts	Fighter	Fighter / Recon	F-35	RPA	KC-135R	Remarks
Maintenance Level	3 Level	2 Level	Parts Mgmt	3 / 2 Level	3 / 2 Level	
Engine / Spares Storage (Unheated)	2,000	2,000	3,200	1,000	800	
Composite Tool Kit (CTK)/Parts	1,000	700		0	0	
Administration	650	450	450	200	200	
PPE Training Bag Storage	96	50	50	50	50	
Classroom / Break / Training / Dispatch	1000	800	400	400	400	
Maintenance Bay	5,000	3,500		1,200	1,800	
Parts Cleaning Room	400	300		0	0	
Bearing & Inspection	300	250		0	0	
Core Automated Maintenance System (CAMS) Computer Room	300	200		0	0	
Subtotal	10,746	8,250	4,100	2,850	3,250	Net SF
15% Overhead	1,612	1,238	615	428	488	
Subtotal	12,358	9,488	4,715	3,278	3,738	
Functional Standard	12,400	9,500	4,700	3,300	3,700	Gross SF

NOTE:

1. MC-12 Recon aircraft will be treated as 2 Level maintenance for fighters, when assigned as a squadron PAA and CLS is converted to Blue Suit Maintenance.

1

Figure 7-9: CATCODE 211-157, F-35 Jet Engine Storage example

Example F-35 Engine Storage 211-157, more efficient ways are encouraged, layout is one example.

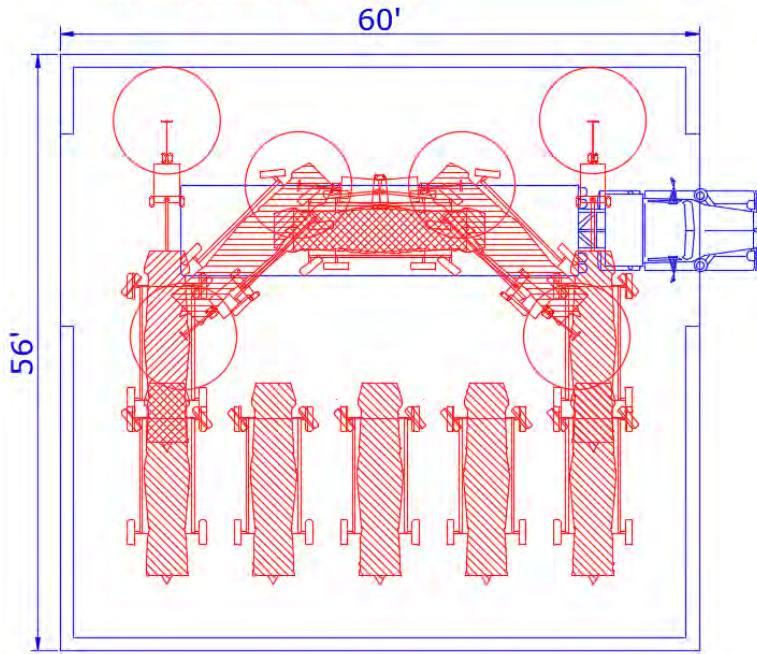

2

3

Table 7-15: CATCODE 211-157, Jet Engine Inspection and Maintenance Shop (Continued)

Major Functions & Breakouts	C-17	KC-46A	XX-130	XX-130	Remarks
Maintenance Level	3 / 2 Level	2 Level	3 Level	3 / 2 Level	
Engine / Spares Storage (Unheated)	2,000	800	1,500	900	
APU & Trailer	500		0	0	
CTK / Parts	500	600	200	100	
Work Station(s)	300	232	0	0	
Administration	200	312	300	300	
PPE Training Bag Storage	50	50	50	50	
Classroom / Break / Training / Dispatch	500	380	400	400	
Maintenance Bay	4,000	734	8,000	5,500	
Parts Cleaning Room	200		300	200	
Bearing & Inspection	0		0	0	
CAMS Computer Room	0	0	0	0	
Subtotal	8,250	3,108	10,750	7,450	Net SF
15% Overhead	1,238	466	1,613	1,118	
Subtotal	9,488	3,574	12,363	8,568	
Functional Standard	9,500	3,600	12,400	8,600	Gross SF

1

2

Table 7-16: CATCODE 211-157, Jet Engine Inspection and Maintenance Shop Summary

Aircraft / Mission	Maintenance Level	Functional Standard (Gross SF)
Fighter (1 - 24 PAA)	3 Level	12,400
Fighter / Recon (1 - 24 PAA)	2 Level	9,500
F-35	Parts Mgmt	4,700
RPA (1 - 18 PAA)	3 Level	9,500
RPA (1 – 18 PAA)	2 Level	3,000
KC-135-R (1 - 12 PAA)	3 / 2 Level	3,700
C-17 (1 - 8 PAA)	3 / 2 Level	9,500
KC-46 (1 - 12 PAA)	2 Level	3,600
XX-130 (1 - 12 PAA)	3 Level	12,400
XX-130 (1 - 12 PAA)	3 / 2 Level	8,600

3

4

7.9 CATCODE 211-159, Aircraft Corrosion Control

7.9.1 Aircraft Corrosion Control provides an environmentally controlled area to wash aircraft, as well as hangar space for corrosion treatment, corrosion repair, paint stripping, and the repainting of limited portions of an aircraft. This facility also provides space for the corrosion control shop, which includes preparation and drying areas, abrasive blasting rooms, and booths for mixing and / or applying paint, tool storage, lockers, and administrative areas.

7.9.2 Corrosion control shops also support small aircraft components, aerospace ground equipment, vehicles, weapons and munitions, and avionics shops.

Table 7-17: CATCODE 211-159, Aircraft Corrosion Control Summary

Aircraft / Mission	Hangar Area (Gross SF)	Shop Area (Gross SF)	Functional Standard (Gross SF)	Remarks
F-15, F-16	6,500	4,600	11,100	
MQ-1 Predator	3,700	0	3,700	See Note 1
MQ-9 Reaper	5,300	2,300	7,600	
MC-12	6,100	2,300	8,400	
KC-46, C-17	0	10,000	10,000	See Note 2 and Note 3
C-130H	0	4,600	4,600	See Note 2
C-130J	0	9,000	9,000	See Note 2 and Note 3
KC-135	0	4,600	4,600	See Note 2

NOTES:

1. Shops addressed in [CATCODE 211-152, Aircraft General Purpose Shops](#) to pair with structures activities.
2. KC-135, KC-46 and C-17 hangar areas can be reduced by designing shaped bays.
3. Clean/dirty room operations and Composites are added in.
4. Not applicable to F-22 and F-35 aircraft.

1
2
3
4
5
6
7
8
9
10

7.10 CATCODE 211-161, Corrosion Control Utility Storage

This facility is a storage building for the aircraft cleaning supplies and cleaning tools that are used at the aircraft wash rack pad. It is authorized if the wash rack is authorized. This facility is only for an open wash rack ([CATCODE 116-672, Aircraft Wash Rack](#)) and is normally situated adjacent to the wash rack. The functional standard is **100 Gross SF**.

Figure 7-10: CATCODE 211-161, Corrosion Control Utility Storage



7.11 CATCODE 211-179, Fuel System Maintenance Dock

Planning guidance for CATCODE 211-179, Fuel System Maintenance Dock, has been updated to improve clarity. The revisions specify that hangar bay sizing should now be based exclusively on the Mission Grouped Hangar Bay dimensions, with the Clean/Dirty Room treated as a separate, added component. For the F-15EX when a Conformal Fuel Tank (CFT) Tester is provided first use excess shop space when available as long as there is direct hangar bay access. Figure 7-11 shows one option if direct access shop space is not available.

Table 7-18: CATCODE 211-179, Fuel System Maintenance Dock Summary

Aircraft / Mission	Hangar Area (Gross SF)	Directly Related Mechanical & Clean Dirty Bathroom	Shop Area (Gross SF)	Functional Standard (Gross SF)
Fighter Aircraft	6,500	2,000	1,500	10,000
F-15EX	6,500	2,000	1,900	10,400
MQ-9	5,300	2,000	1,500	8,800
XX-130	20,000	2,000	1,700	23,700
KC-135, KC-46, and C-17 ¹ and ²	36,500	3,000 ²	2,500	42,000

NOTES:

1. Must fit C-17 with square footage and elevation.
2. Body Fuel Tanks storage of 1,000SF is included
3. A concrete pad with utility support is authorized for the installation of equipment that will allow for vertical storage of aircraft fuel tanks. See NGB/A4 for the financing of the equipment. The pad will be authorized under [CATCODE 132-133, Equipment Pad](#). In lieu of vertical storage can install a 60x60 three sided carport (3,600 Gross SF) using [CATCODE 214-428, Vehicle Operations Parking Shed](#), on the equipment pad for 18 or 21 600-Gallon Drop Tanks, coordinate with NGB/A4.

Figure 7-11: CATCODE 211-179, Fighter Fuel System Mx Dock with Shops

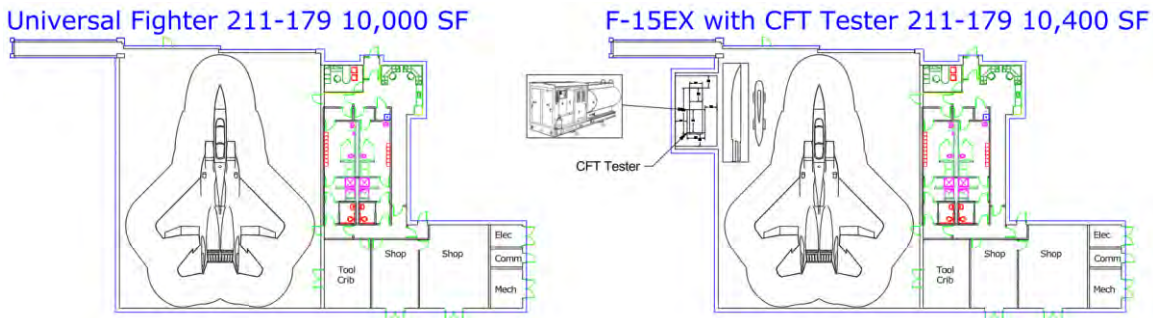
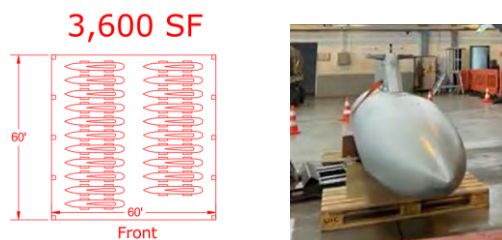

Figure 7-12: F15-EX Drop Tank layout for 18 or 21PAA, each tank on cradles



1 7.12 **CATCODE 211-193, Test Stand**

2 Facility designed for testing aircraft engines. Test stand consists of technical equipment which
3 retains its identity as equipment. Provide one concrete pad with utilities where aircraft specific test
4 stand equipment is located. See [CATCODE 116-664, Unsuppressed Power Check Pad](#) and
5 [CATCODE 211-157, Jet Engine Inspection and Maintenance Shop](#) for additional information.
6 Test stands are authorized for C-130 only.

7
8

1 7.13 **CATCODE 214-422, Vehicle Service Rack**

2 This structure (not a building) is used to service government vehicles only and is not enclosed
3 (see Figure 7-13) – the shed should be equipment for storage of hoses. All portions of CATCODE
4 214-422 will follow the Real Property rules for a Structure. The open slab structure is normally
5 located in a vehicle maintenance facility area and provides washing of military vehicle exteriors,
6 undercarriages, and power trains. 214-422 typically consists of prepared surfaces, a wash
7 station, hose connections, wash water containment and Drains, sedimentation basin, oil and
8 water separator, and sludge removal. Each installation or GSU that is authorized a CATCODE
9 214-425, Vehicle Maintenance Shop is authorized one each (1) 214-422 Vehicle Service Rack /
10 Wash Rack. 214-422 to be fenced and separated from base population POV assets to prevent
11 other than GOV to use the wash rack. [CATCODE 214-425, Vehicle Maintenance Shop](#) is
12 authorized one smaller enclosed Wash Rack as part of the assigned Square Footage per the 214-
13 425 table.

14 **Figure 7-13: CATCODE 214-422 per 2016 AF Category Code book**



15
16 Military Vehicle Wash Rack, Barksdale AFB LA
17
18

7.14 **CATCODE 214-425, Vehicle Maintenance Shop**

Maintains all authorized government-owned (GOVs) assigned to a base – not General Services Administration (GSA) or leased (see Figure 7-14). Provides shop space and facilities for lubrication, inspection, general repair, and replacement of major assemblies (such as above-ground vehicle hoists), as well as welding, upholstery, testing, cleaning, and minor parts fabrication. Does not include Refueler Vehicles; see [CATCODE 214-467, Refueling Vehicle Shop](#). Do not count GSA or leased vehicles.

Table 7-19: CATCODE 214-425, Vehicle Maintenance Shop

Major Functions & Breakouts	Authorized Staffing	Target Area (SF)	Remarks
Tool Crib	1		
Material Control / Bench Stock			
Battery Shop			
Wheel & Tire Shop	1		
Machine Shop / Welding Area	1		
General / Special Purpose Vehicle Maintenance Bays	5		
Wash Bay	1		
Subtotal		4,700	Net SF
15% Overhead		705	
Subtotal		5,405	
Functional Standard		5,400	Gross SF

NOTES:

1. This function is intended to be collocated with [CATCODE 610-121, Vehicle Operations Administration](#) .
2. 214-425 includes 900 SF enclosed Vehicle Wash Bay which is a Real Property Building not to be confused with a 214-422 open slab Wash Rack that is a Real Property Structure not a Building.
3. This functional standard is for units with 201 to 300 Vehicle Equivalents (VE's)
4. Add 800 Gross SF for each additional 100 VE's above 300.
5. The functional standard for Aircraft Ranges and units with 100-199 VE's is 4,900 Gross SF.
6. Units with less than 100 VE's should consult with NGB/A4FR to determine the functional standard.
7. Units with unique / special requirements should contact NGB/A4FR to determine functional standard.

1 **Figure 7-14: Proof of concept for Typical Vehicle Maintenance Admin, Shops, & Refueler**

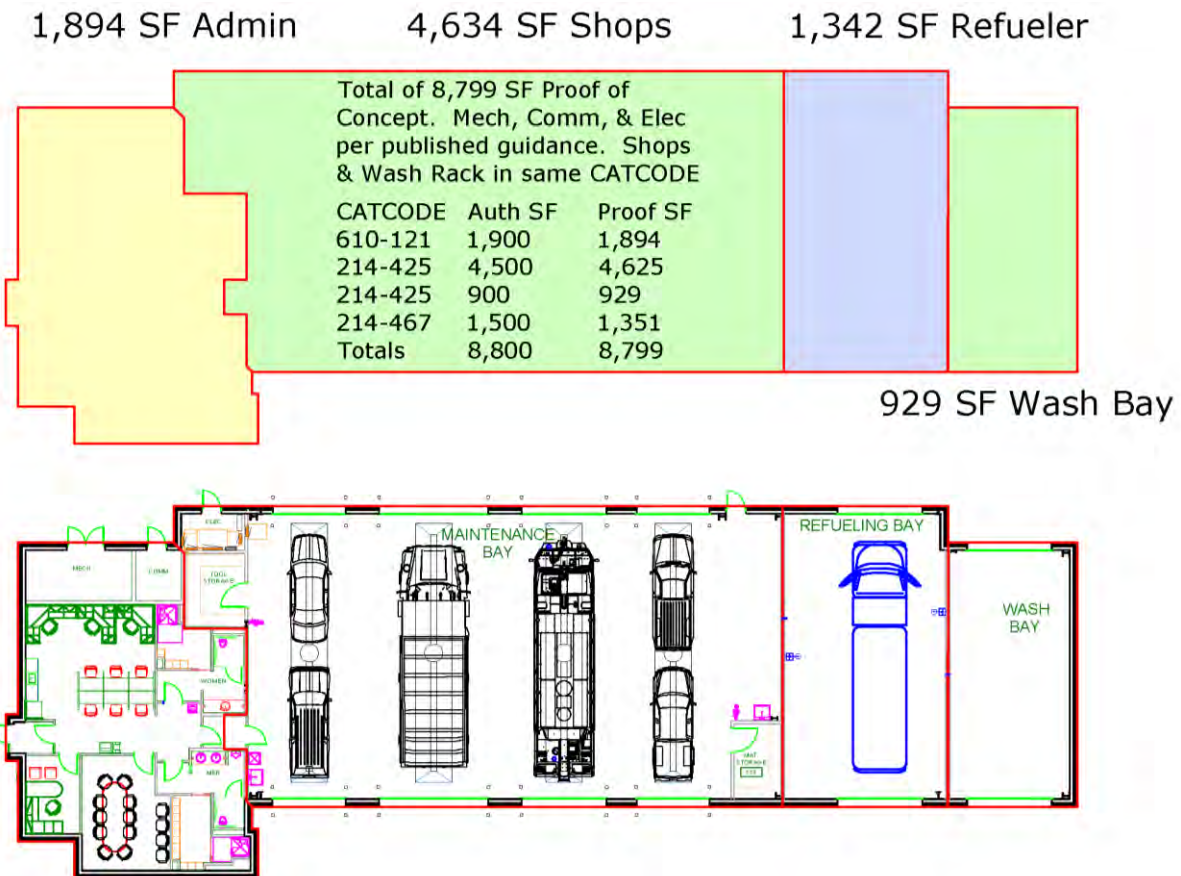

2
 3 Above shows CATCODE 214-467 as a donor of less than 10% to 214-425 which is at BCE in coordination with A4FD level
 4 which would be noted in the 920 thus 214-467 and 214-425 is within the combined scope.

5

7.15 CATCODE 214-426, Vehicle Operations Heated Parking

- 7.15.1 This facility is provided for government assigned vehicles at installations located in cold climates; see [Weather Extremes](#) in Appendix C and [Northern Tier Locations](#).
- 7.15.2 CATCODE 214-428, with block heaters could be another option depending on mission needs.
- 7.15.3 Excludes specialty vehicles that are already accounted for such as fire trucks (130-142), and BCE equipment [CATCODE 219-943, Base Civil Engineer Pavement and Grounds](#).
- 7.15.4 For cold climate installation's excess snow removal that does not fit within 219-943 can be requested to A4F for approval to use 214-426 minimally heated (freeze protection) fully enclosed shed(s).
- 7.15.5 For cold climate installations refueling vehicles could also be requested to A4F for approval to use 214-426 minimally heated (freeze protection) fully enclosed shed(s).
- 7.15.6 If approved to use 214-426 the number of vehicles parked in heated buildings varies with the flying mission and type of operation. Not more than four large refueling units (such as the R-11 type) should be parked in a single structure. A typical two R-11 building will require up to **2,800 Gross SF** for angled parking or up to **2,500 Gross SF (50'x50')** for straight parking to maintain a twenty-five (25) feet center-to-center between fueling vehicles in parking areas, see AFI 91-203, para 36.3.5.2.3 and UFC 3-460-01, fuel delivery vehicle parking. An installation that warrants more than four refueler units may define a single structure as a two-hour rated firewall separating every four bays. Provide adequate natural ventilation, floor drainage to further reduce hazards related to fuel spillage or leaks, and some type of fire protection sprinkler system.

Figure 7-15: Example square footage for angled parking vs straight parking

Two R-11 Refueler covered parking

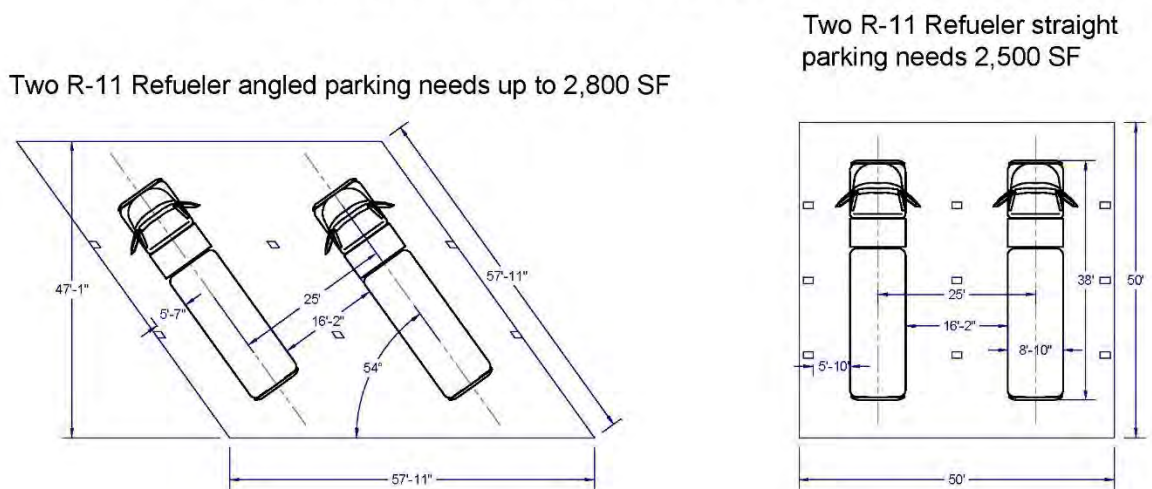

7.16 CATCODE 214-428, Vehicle Operations Parking Shed

- 7.16.1 This facility is a one, two or three sided roofed structure with no expectation of having doors and fire protection with Gross SF as full scope thus 1,000SF Parking Shed counts as 1,000SF because the un-enclosed shed is the intended purpose of parked vehicles. It is an unheated parking shed that is provided for certain essential vehicles in areas of heavy snow or abnormality high heat. For extreme heat areas only metal canopy (no sides) are authorized. Fabric-type sunshades are not real property and therefore are not included in this CATCODE.
- 7.16.2 For refueling vehicles, allow no more than four refueling vehicles per shed and provide twenty-five (25) feet center-to-center between fueling vehicles.
- 7.16.3 For AGE equipment contact NGB/A4F. Most AGE equipment is designed to be stored without a covered shed.
- 7.16.4 Excludes specialty vehicles that are already accounted for such as fire trucks (130-142), and BCE equipment (219-943).

Table 7-20: CATCODE 214-428, Vehicle Operations Parking Shed

Vehicle Equivalents	Functional Standard (Gross SF)
5 - 50	2,500SF
51 - 150	4,000SF
151 - 250	6,000SF
251 - 350	8,000SF
351 - 450	10,000SF
451 or more	Contact NGB/A4F

7.17 **CATCODE 214-467, Refueling Vehicle Shop**

AFOSH STD 127-20, Vehicle Maintenance Shops, prohibits servicing or repairing fuel servicing tank units and hydrant hose trucks in maintenance shops with other vehicles; therefore, the refueling vehicle shop is a separate, complete maintenance and repair bay that includes a work area, mechanical ventilation, and wet-pipe sprinkler system. The repair bay in this facility will safely accommodate the R-11 refueler, a 25K loader, or the new Stryker 1500 (P-19) and Stryker 3000 (P-23) fire trucks. Units with a 60K loader are authorized an additional 600 Gross SF. This facility is normally collocated with [CATCODE 214-425, Vehicle Maintenance Shop](#).

Table 7-21: CATCODE 214-467, Refueling Vehicle Shop

Type of Unit	Functional Standard (Gross SF)
Flying	1,500
Non-flying	800

NOTE:

- Up to 300 Gross SF for a flying function and 100 Gross SF for a non-flying function are used for utility / mechanical rooms.

7.18 CATCODE 215-552, Weapons and Release Systems Shop

7.18.1 Provides space for the overhaul and repair of fighter aircraft and RPA weapons release and gun systems that include, but are not limited to bomb racks, weapons pylons, ejection racks, and aircraft gun systems. Also provides shop and tool space for the maintenance, upkeep of weapons loading tools and equipment, as well as dispatch to the flight line. Besides normal shop space, the facility encompasses a gun and / or ejector unit cleaning room, maintenance offices, a dispatch office, and a bench stock room, plus storage space for test equipment, alternate mission equipment (AME), spare gun systems, and mobility equipment.

7.18.2 For RPA Launch & Recovery Element locations, use the fighters functional standard where required.

Table 7-22: CATCODE 215-552, Weapons and Release Systems, Fighters, Admin, 64 Personnel

Major Functions & Breakouts	Authorized Staffing	Target Area (SF)	Remarks
Admin / Training	1	1,010	Net SF
Weapons Manager	1		Position is auth under Munitions Loading
Training & Testing			See Chapter 1
Conference & Meeting			See Chapter 1
Gun Shop	11	1,070	Net SF
Weapons Element Supervisor	1		
Gun Cleaning Shop	2		
Gun Services Shop	8		
Bench Stock / Tool Crib			
Release	13	1,120	Net SF
Supervisor NCOIC	1		
Weapons Release Shop	12		
Loading	39	9,120	Net SF
Weapons Loading Supervisor	1		
Weapons Loading Shop	38		
Storage			
Support	0	196	Net SF
Break Area			
PPE Training Bag Storage			
Subtotal		12,516	Net SF
15% Overhead		1,877	
Subtotal		14,393	
Functional Standard		14,400	Gross SF

1 **Table 7-23: CATCODE 215-552, Weapons and Release Systems, Rescue HH-60 & HC-130, Admin, 12 Personnel**

Major Functions & Breakouts	Authorized Staffing	Target Area (SF)	Remarks
Admin / Training	3	248	Net SF
Weapons Manager	1		
Weapons Load Management NCOIC	1		
Armament Management NCOIC	1		
Gun Shop	9	950	Net SF
Gun Cleaning Shop	2		
Gun Services Shop	7		
Bench Stock / Tool Crib			
Support	0	540	Net SF
Break Area			
Storage			
PPE Training Bag Storage			
Subtotal		1,738	Net SF
15% Overhead		261	
Subtotal		1,999	
Functional Standard		2,000	Gross SF

2

3 **Table 7-24: CATCODE 215-552, MQ-9, Remotely Piloted Aircraft (RPA), Total Admin and Shop**

Major Functions & Breakouts	Authorized Staffing	Target Area (SF)	Remarks
Weapons Manager	1		
Bench Stock / Tool Crib			
Weapons & Release Shop			
Support			
Subtotal		920	Net SF
15% Overhead		138	
Subtotal		1,058	
Functional Standard		1,100	Gross SF

4

5

7.19 CATCODE 216-642, Conventional Munitions Shop

7.19.1 Five functions are in this CATCODE: Admin (office space), inert storage, Trailer Mx, M&I, and Inspections (ALA practice process/insp, munitions inspection bay, BDU practice processing, and tool room). These facilities are designed, constructed, and analyzed by an approved DOD engineering firm for placement, orientation, and separation to establish QD Arc evaluations and site approval. Munitions facilities shall be separated based on QD arcs.

7.19.1.1 Munitions Administrative, Inert Storage and Trailer Maintenance Facility: The administration, trailer maintenance and munitions inert storage should be built as an integral facility and separated from the munitions maintenance and munitions storage facilities. The facility consists of drive-through work bay(s) (one area with a bridge crane), office space, control center, training areas, inert storage, and latrines (no munitions). Example layout shown below:

Figure 7-16: CATCODE 216-642, Example Layout Admin, inert storage, and trailer Mx

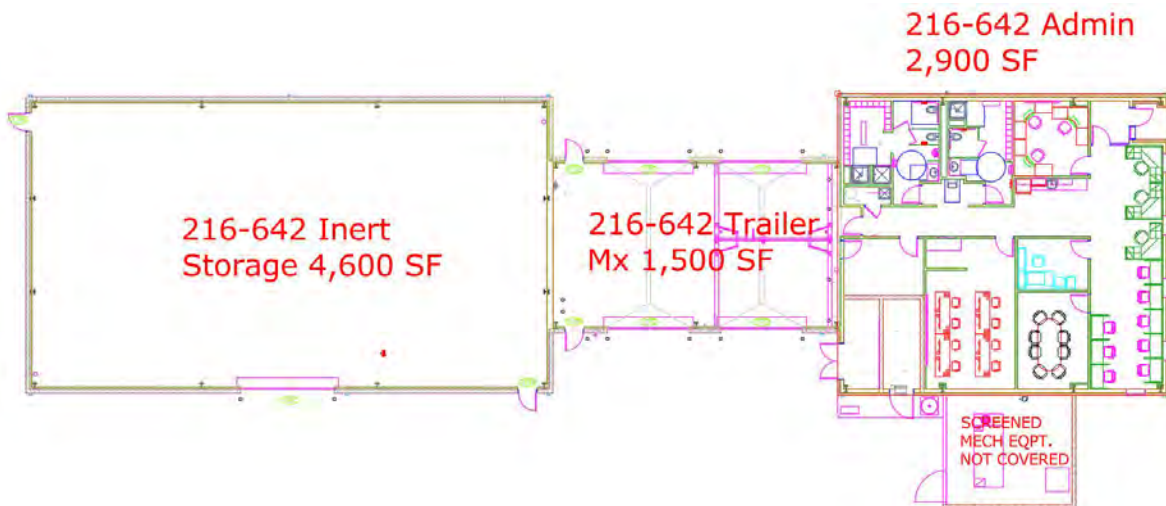

7.19.1.2 Munitions Maintenance Facilities: The missile maintenance, munitions inspection and service bays should be built as two facilities located in close proximity. The Missile Maintenance Facility consists of two missile maintenance bays, mechanical room, electrical room, and communications room. The Munitions Maintenance & Inspection Facility consists of 3 or 4 bays; Munitions Inspection Bay, Ammunition-Loading System / Universal Loading System (ALS/ULS) Processing / Inspection Bay, Practice Process Bomb, Dummy Unit (BDU) Processing/Inspection Bay, and Munitions Equipment Bay (can combine Processing/Inspection Bay, and Munitions Equipment Bay into one bay). Example (see Figure 7-17) shows both M&I and Inspections, Example Site Plan (see Figure 7-18) showing separation of M&I and Inspections based on QD arcs:

1

Figure 7-17: CATCODE 216-642, Example Layout M&I and Inspections

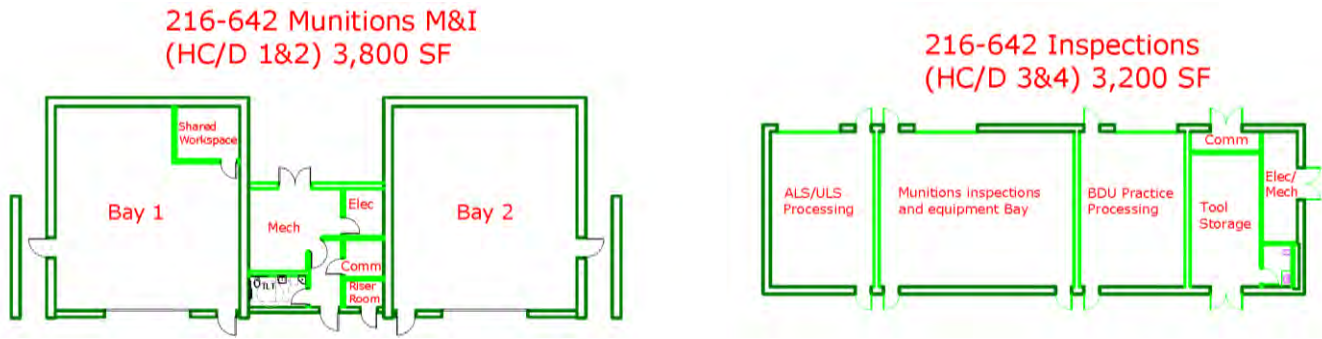

2

3

Figure 7-18: CATCODE 216-642, Example Munitions Site Plan showing M&I separation to Inspections. The separation distance is always based on DDESB approved explosive site plans.

6

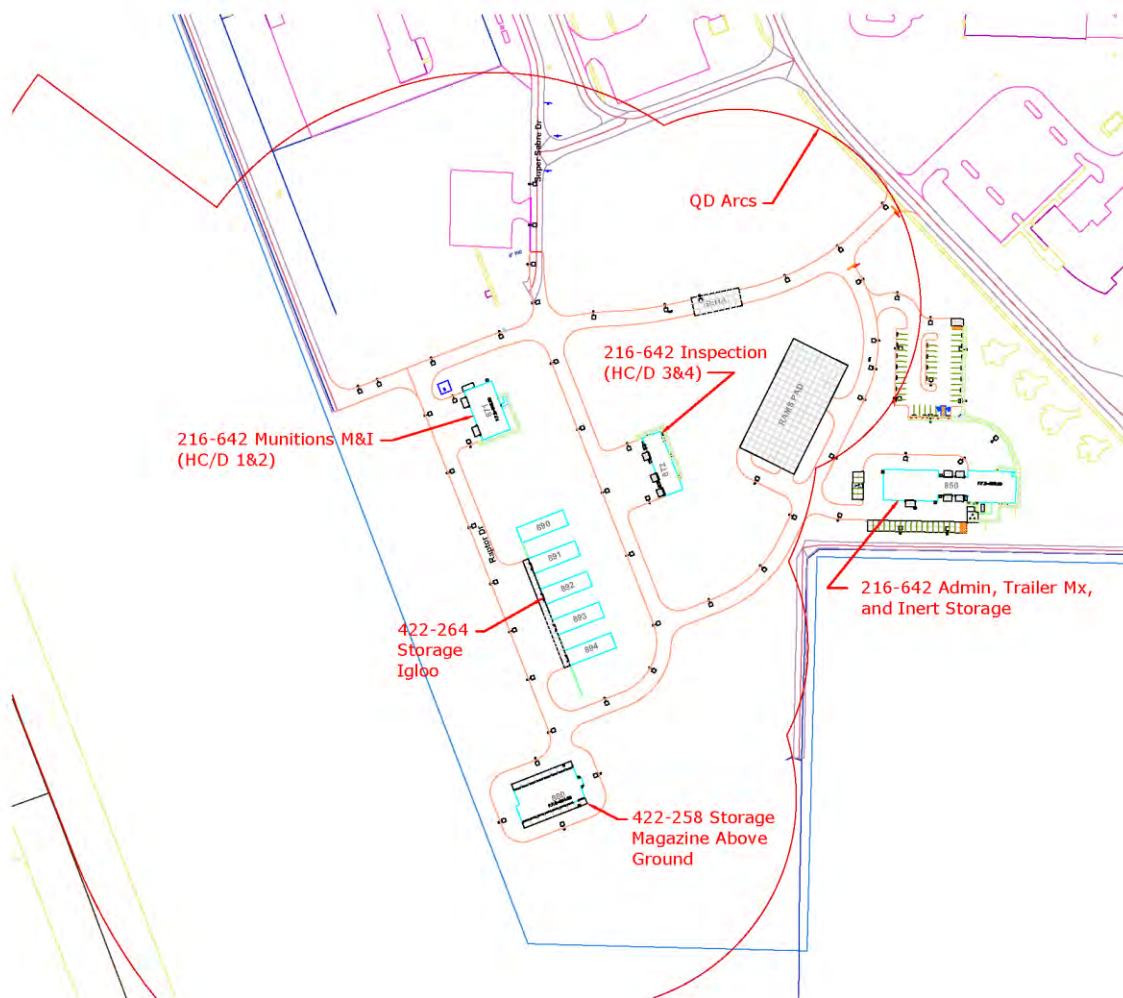

7

8

7.19.1.3 Munitions and Missile Storage Facilities: Explosives storage shall be separate facilities from the above and are covered under [CATCODE 422-264, Storage Igloo](#) for munitions storage.

7.19.2 Special Features: The 216-642 missile bays and trailer maintenance bay require a transverse mounted overhead crane. All maintenance bays must have two means of egress in addition to the bay access door(s). Each facility must be sited to comply with the quantity-distance (QD) separation criteria established in DESR 6055.09_AFMAN 91-201, *Explosives Safety Standards*. The lightning protection and ground system shall follow the requirements of the *National Electrical Code* and DESR 6055.09_AFMAN 91-201.

Table 7-25: CATCODE 216-642, Conventional Munitions Shop, Admin

Major Functions & Breakouts	Authorized Staffing							Target Area (SF)							Remarks
	F-15 / F-22 / RPA	F-16	F-35/F-15EX	Rescue Wing	CRTC	Tanker/Airlift	C-130J	F-15 / F-22 / RPA	F-16	F-35/F-15EX	Rescue Wing	CRTC	Tanker/Airlift	MC-130J 193 SOW	
Flight Chief	1	1	1	1		1	1								
Flight Chief Visiting Unit															
Training & Testing							9								See Chapter 1
Conference & Meeting															See Chapter 1
Production Chief	1	1	1	1			1								
Material Chief	1	1	1				1								
System Chief	1	1	1												
Munitions Control	1	1	1	2		1	1								
Munitions Control (Visiting Unit)															
Personal Lockers															
Storage															
Dispatch															
Break Area															
PPE Training Bags															
Subtotal								2,338	2,591	2,871	1,379	2,212	869	1,132	Net SF
25% Overhead								584	648	718	345	553	87	283	
Subtotal								2,922	3,238	3,588	1,724	2,765	956	1,414	
Functional Standard	37	59	79	10		6	13	2,900	3,200	3,600	1,700	2,800	960	1,400	Gross SF

11
12
13

1

Table 7-26: CATCODE 216-642, Conventional Munitions Shop, Trailer Maintenance

Major Functions & Breakouts	Target Area (SF)							Remarks
	F-15/F-22/RPA	F-16	F-35/F-15EX	Rescue Wing	CRTC	Tanker/Airlift	MC-130J 193 SOW	
Trailer Maintenance	1,500	1,500	1,500	n/a	1,500	n/a	n/a	Gross SF

2

Table 7-27: CATCODE 216-642, Conventional Munitions Shop, Maintenance

Major Functions & Breakouts	Target Area (SF)							Remarks
	F-15/F-22/RPA	F-16	F-35/F-15EX	Rescue Wing	CRTC	Tanker/Airlift	MC-130J 193 SOW	
Maintenance & Inspection (HC/D 1&2)								See Note 1
Inspections (HC/D 3&4): ALS/ULS Processing/Inspections Bay, BDU Processing/Inspection Bay, Processing/Inspection Bay and Munitions Equipment Bay								
Subtotal	5,600	5,600	5,600	1,000	3,090	240	840	Net SF
25% Overhead	1,400	1,400	1,400	250	773	60	210	Increased overhead due to wall thickness required
Subtotal	7,000	7,000	7,000	1,250	3,863	300	1,050	
Functional Standard	7,000	7,000	7,000	1,300	3,900	300	1,050	Gross SF

3

4

NOTES:

5

- Units handling live missiles are authorized an additional 600 SF to increase one of the two bay for M&I (HC/D 1&2). Both will be earth covered with earth filled walls. One bay will contain an office / secured area. Both bays must have two means of egress in addition to the bay access door (see Figure 7-17).

6

7

8

Table 7-28: CATCODE 216-642, Conventional Munitions Storage

Major Functions & Breakouts	Target Area (SF)							Remarks
	F-15/F-22/RPA	F-16	F-35/F-15EX	Rescue Wing	CRTC	Tanker/Airlift	MC-130J 193 SOW	
Munitions Support Equipment Storage								Primarily Trailers
Subtotal	4,000	4,000	4,000	1,000	4,000		1,000	Net SF
15% Overhead	600	600	600	150	600		150	
Subtotal	4,600	4,600	4,600	1,150	4,600		1,150	
Functional Standard	4,600	4,600	4,600	1,200	4,600	0	1,200	Gross SF

9

NOTE:

10

- Munitions Support Equipment Storage is normally collocated with Conventional Munitions administrative facility.

11

1

Table 7-29: CATCODE 216-642, Conventional Munitions Shop Totals

Functional Area	F-15, F-22, RPA (SF)	F-16 (SF)	F-35/E-15EX (SF)	Rescue Wing (SF)	CRTC (SF)	Tanker/Airlift (SF)	MC-130J 193 SOW
Admin with Trailer Maintenance Functional Target	2,900	3,200	3,600	1,700	2,800	960	1,400
Trailer Maintenance	1,500	1,500	1,500	1,500	1,500	n/a	n/a
Maintenance Functional Target	7,000	7,000	7,000	1,300	3,900	300	1,050
Inert Storage Functional Target	4,600	4,600	4,600	1,200	4,600	0	1,200
Functional Standard (Gross SF)	16,000	16,300	16,700	5,700	12,800	1,260	3,650

2

3

NOTES:

4

1. Tanker/Airlift is shown as Gross SF for above ground prefab standard size of 300 SF for Maintenance Function.

5

2. Units other than Tanker/Airlift with chaff / flare commitment would require a 300 SF maintenance / inspection.

6

3. Units with only Logistics Readiness Squadron/Munitions Systems, AFSC 2W051/2W071, personnel would require 300 SF admin and 300 SF maintenance/inspection.

7

8

4. Fighter units with a general-purpose (GP) mission are authorized a Munitions Assembly Conveyor (MAC) [AKA Rapid Assembly Munitions System (RAMS)] pad typically about 2,222 SY (100 ft x 200 ft pad) that will be listed under [CATCODE 422-275, Ancillary Explosives Facility](#)

9

10

11

12

13

14

7.20 CATCODE 217-712, Avionics Shop

- 7.20.1 Major items that require shop and storage space include storage racks for serviceable equipment and equipment awaiting maintenance or parts, coding devices, technical data and code books, and pod lifting devices, cradles, and storage racks. Some storage space provides physical security and corrosion protection for delicate electronic equipment; if possible, combine maintenance and storage facilities to share the secure storage area.
- 7.20.2 The Avionics Shop accommodates organizational and intermediate-level maintenance activities for airborne communication, camera, bombing system, and Tactical Support Element Communications (TSEC) / COMSEC equipment.

Table 7-30: CATCODE 217-712, Avionics Shop Summary

Aircraft / Mission	Functional Standard (Gross SF)
RPA	1,000
KC-135	5,400
KC-46	3,100
C-17	5,400
C-130 E / H / J	6,400
Fighter	9,200
MC-12	2,000
CRTC	3,000

Table 7-31: CATCODE 217-712, Avionics Shop Fighters Details

Major Functions & Breakouts	Authorized Staffing	Target Area (SF)	Remarks
Admin	0	890	Net SF
Conference & Meeting			
Training & Testing			
Operations	54	6,280	Net SF
Superintendent	2		
Maintenance Manager	10		
Avionics Flight Line Shop	26		
Intermediate Shop	12		
AIS Vault			
Precision Lab	4		
Storage			
Support	0	181	Net SF
Break Area			
PPE Training Bag Storage			
Subtotal		7,351	Net SF
25% Overhead		1838	
Subtotal		9,189	
Functional Standard	54	9,200	Gross SF

7.21 CATCODE 217-713, Electronic Countermeasures (ECM) Pod Shop and Storage

This function (normally collocated with CATCODE 217-712, Avionics Shop) contains maintenance areas and storage for conventional pods and associated equipment. Additional space for special pods is authorized only when assigned at an installation for the following missions:

Table 7-32: CATCODE 217-713, ECM Pod Shop and Storage

Aircraft / Mission	Functional Standard (Gross SF)
ECM Pod Shop / Storage (A-10 & F-16)	(see next table)
RECCE / TARS Pod Shop / Storage (Fighters)	2,500
HARM Pod Storage (Fighters)	1,000
Air Defense ECM Facility	1,000
LANA / LANTIRN / LITENING (fighters)	2,500 (See Note 1)
C-130XX / HC-130 / C-17	2,700

NOTE:

1. Add 1,200 Gross SF of covered space for mobile set.

Table 7-33: CATCODE 217-713, ECM Pod Shop and Storage for A-10 and F-16

Function	Up to 20 ALQ-184/131 Pods	Up to 36 ALQ-184/131 Pods	Up to 60 ALQ-184/131 Pods
Admin	691	813	885
Tool Room/Bench Stock	220	275	320
Pod Shop	1,800	2,100	2,300
Pod Storage	1,300	1,400	1,650
Break Room and PPE Trng Bag Strg	126	136	145
Functional Standard (Gross SF)	4,800	5,400	6,100

Figure 7-19: CATCODE 217-713, ECM Pod Shop/Storage Layouts

Up to 20 ALQ-184/131 Pods



Up to 36 ALQ-184/131 Pods



Up to 60 ALQ-184/131 Pods

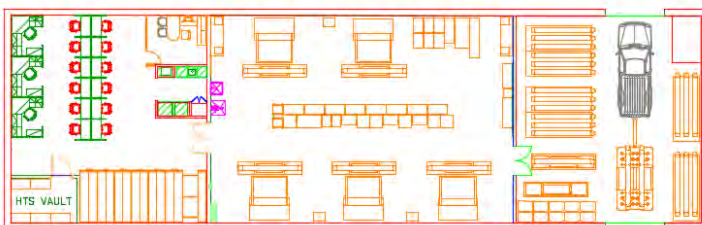

7.22 CATCODE 218-712, Aircraft Support Shop / Storage

The AGE shop inspects, maintains, repairs, and services both powered and non-powered equipment that directly supports aircraft, as well as powered-munitions AGE (if assigned). The facility normally includes maintenance stalls with workbenches, hoists, indoor wash bay (in cold weather climates), tool crib, bench stock, sealed lead acid battery servicing area, engine exhaust extraction system, administrative space, and personal locker space. For open storage see [CATCODE 852-273, Aircraft Support Equipment Storage Yard](#). For covered shed storage use AGE equipment to store under a covered shed see [CATCODE 214-428 Vehicle Operations Parking Shed](#).

Table 7-34: CATCODE 218-712, Aircraft Support - Command & Control

Major Functions & Breakouts	Authorized Staffing	Target Area (SF)	Remarks
Flight Chief	1		
Production Supervisor	1		
Training & Testing			See Chapter 1
Conference & Meeting			See Chapter 1
Administration	1		
T.O. / Library			
Section Chief / Team Leader	1		
Scheduler	1		
Supply Specialist	1		
Pickup / Delivery Personnel			Use Training Room for stand-by
Break Area			
PPE Training Bag Storage			
Subtotal		1,197	Net SF
25% Overhead		299	
Subtotal		1,496	
Functional Standard		1,500	Gross SF

Table 7-35: CATCODE 218-712, Aircraft Support Equipment – Support

Major Functions & Breakouts	Authorized Staffing	Target Area (SF)	KC-46	Remarks
Tool Crib				
Material Control / Bench Stock				
Battery Shop				
Parts Cleaning Room				
Inspection Section				Use Work Bays
General Purpose Equipment Maintenance & Repair Bays	8			4 Work Bays
Wash Bay				
Subtotal		3,400	4,700	Net SF
15% Overhead		510	705	
Subtotal		3,910	5,405	
Functional Standard		4,000	5,400	Gross SF

Table 7-36: CATCODE 218-712, Aircraft Support Equipment - Storage

Major Functions & Breakouts	Authorized Staffing	Target Area (SF)	KC-46	Remarks
Enclosed / Covered		3,000	4,000	
Subtotal		3,000	4,000	Net SF
15% Overhead		450	600	One enclosed area only
Subtotal		3,450	4,600	
Functional Standard		3,500	4,600	Gross SF

NOTES:

1. One enclosed area only.
2. Add 900 Gross SY for paved yard under [CATCODE 852-273, ASE Storage Yard](#).

Table 7-37: CATCODE 218-712, Aircraft Support Equipment Summary

Function	100 to 200 pieces of AGE	200 to 300 pieces of AGE	Over 300 pieces of AGE	KC-46
ASE C & C	1,500	1,500	1,500	1,500
ASE Support	3,200	4,000	4,800	5,400
ASE Storage	2,700	3,500	4,300	4,600
ASE Total Gross SF	7,400	9,000	10,600	11,500 see note 5

NOTES:

1. This functional standard is for units with 200 to 300 pieces of AGE.
2. Add 1,600 Gross SF (800 Gross SF for another work bay, 800 Gross SF for enclosed / covered storage), and 300 Gross SY for paved yard) for each 100 additional pieces of AGE above 300 pieces. Subtract 1,600 Gross SF in the same 800 Gross SF Support and 800 Gross SF Storage for each additional 100 pieces below 200 (7,400 SF for below 200 pieces of AGE down to 5,800 SF for below 100 pieces of AGE.)
3. For severe weather or heavy snow locations, covered storage is enclosed with minimal heat to prevent freeze protection. For hot weather locations, covered storage is a shed (sun cover and up to 3 sides).
4. Do not provide maintenance or storage space for munitions trailers in the AGE Shop as it is provided in the [CATCODE 216-642, Conventional Munitions Shop](#).
5. Add 8,800 SF under [CATCODE 214-428 Vehicle Operations Parking Shed](#) for KC-46 AGE covered shed storage.
6. Units with unique / special requirements must request a variance from NGB/A4F (See Appendix B).

7.23 CATCODE 218-868, Regional Precision Measurement Equipment Lab (PMEL)

7.23.1 This facility provides field-level maintenance and calibration of test, measurement, and diagnostic equipment (TMDE) for assigned units. PMEL personnel calibrate and certify TMDE at regular intervals; they also provide emergency assistance on TMDE, as required.

7.23.2 The laboratory requires an environment controlled for temperature, humidity, and dust; calibration and repair activity must also be free of interfering vibration.

Table 7-38: CATCODE 218-868, Regional Precision Measurement Equipment Lab (PMEL)

Major Functions & Breakdowns	SELFRIDGE	FORBES	DULUTH	OTIS	Remarks
Number of Items over 10,000	See Note 1	See Note 1	See Note 1	See Note 1	
Calibration/Repair	5,344	5,871	7,302	6,975	See Note 2
Additional from Table 2	604	483	379	1,167	See Note 3
Scheduling / Receiving	1,981	2,116	2,558	2,711	See Note 3
Air Lock (2 air locks)	108	108	108	108	See Note 3
T.O. / Training	229	229	229	229	See Note 3
Office Space	888	774	952	994	See Note 4
Meeting Space / Break Room	800	780	820	920	See Note 5
Subtotal	9,954	10,361	12,348	13,104	Net SF
25% Overhead	2,489	2,590	3,087	3,276	
Subtotal	12,443	12,951	15,435	16,380	
Functional Standard	12,400	13,000	15,400	16,400	Gross SF

NOTES:

1. Number of Items over 10,000: Selfridge (317), Forbes (1,371), Duluth (4,234) and Otis (3,579).
2. Per FC 4-218-01F and CC 218868 Table 1-1.
3. Per FC 4-218-01F and CC 218868 Table 1-2.
4. Office space calculated based on authorized staffing standards using ANGH 32-1084, Chapter 1 "[Administrative Area Standards](#)".
5. Calculated using ANGH 32-1084 Chapter 1, Table 1-3.

1 7.24 **CATCODE 219-943, Base Civil Engineer Pavement and Grounds**

2 This **8,000 Gross SF** function is normally comprised of three work centers, each with its own
3 small (100 Net SF) office: ‘pavements’ (maintains paved surfaces; constructs and repairs airfield,
4 roadway, and parking areas), ‘equipment operations’ (handles use of construction and special
5 purpose equipment, such as backhoes, dump trucks, airfield sweepers, and bulldozers), and
6 ‘grounds’ (base landscaping, maintenance of road signs and fencing). Units that contract
7 landscaping or do not maintain pavements are authorized **4,000 Gross SF** for heavy equipment
8 storage. **Add 1,000 Gross SF** for [Northern Tier Locations](#) with MEOC, see [CATCODE 610-913](#).

9

7.25 CATCODE 219-944, Base Civil Engineer Maintenance Shop

7.25.1 The primary production center of civil engineering, its activities include structures (metals, carpentry, masonry, etc.), electrical (interior / exterior), power production, utilities (plumbing, water and waste, etc.), liquid fuels, entomology, HVAC (heating, ventilation, air conditioning, refrigeration, Energy Management Control System (EMCS), etc.), along with work control, material control, shop supervisors and tool room area.

7.25.2 The Base Civil Engineer Maintenance Shop is normally collocated with [CATCODE 610-127, Base Civil Engineer Administration](#).

7.25.3 Base Civil Engineering Maintenance Shop, Flying Unit

Table 7-39: CATCODE 219-944, BCE Maint Shop, Flying Unit

Major Functions & Breakouts	Authorized Staffing	Target Area (SF)	Remarks
Administration	12	1,018	Net SF
Work Control	5		
Material Control	1		
Shop Supervisor(s)	6		
Tool Room / Bench Stock			
Shops	40	1,800	Net SF
Electrical, Internal / External	5		
Power Production	7		
HVAC	5		
Pavements	7		
Structures	7		
Utilities, Plumbing / Water / Waste	7		
Storage	0	1,850	
Mobility Equip Storage / Pallet Buildup			9 pallets x 100 SF each + 950 SF access
Subtotal		4,668	Net SF
15% Overhead		700	
Subtotal		5,368	
Functional Standard		5,400	Gross SF

7.25.4 Base Civil Engineering Maintenance Shop, RED HORSE

Table 7-40: CATCODE 219-944, BCE Maint Shop, 1/2 RED HORSE Sqd

Major Functions & Breakouts	Authorized Staffing	Target Area (SF)	Remarks
Administration	21	1,722	Net SF
Work Control	3		
Shop Supervisor(s)	18		
Tool Room / Bench Stock			
Shops	124	4,600	Net SF
Electrical, Internal / External	10		
Power Production	5		
HVAC	4		
Pavements	64		
Structures	34		
Utilities, Plumbing / Water / Waste	7		
Storage	0	1,850	
Mobility Equip Storage / Pallet Buildup			9 pallets x 100 SF each + 950 SF access
Subtotal		8,172	Net SF
15% Overhead		1,226	
Subtotal		9,398	
Functional Standard		9,400	Gross SF

NOTES:

- See [1/2 RED HORSE squadron and 1/4 RED HORSE squadron ANG locations.](#)

Table 7-41: CATCODE 219-944, BCE Maint Shop, 1/4 RED HORSE Sqd

Major Functions & Breakouts	Authorized Staffing	Target Area (SF)	Remarks
Administration	6	706	Net SF
Work Control	1		
Shop Supervisor(s)	5		
Tool Room / Bench Stock			
Shops	80	3,500	Net SF
Electrical, Internal / External	6		
Power Production	4		
HVAC	4		
Pavements	44		
Structures	16		
Utilities, Plumbing / Water / Waste	6		
Storage	0	1,850	
Mobility Equip Storage / Pallet Buildup			9 pallets x 100 SF each + 950 SF access
Subtotal		6,056	Net SF
15% Overhead		908	
Subtotal		6,964	
Functional Standard		7,000	Gross SF

NOTES:

- See [1/2 RED HORSE squadron and 1/4 RED HORSE squadron ANG locations.](#)

7.25.5 Base Civil Engineering Maintenance Shop, CRTC

Table 7-42: CATCODE 219-944, BCE Maint Shop, CRTC

Major Functions & Breakouts	Authorized Staffing	Target Area (SF)	Remarks
Administration	6	810	Net SF
Shop Supervisor	1		
Work Control	2		
Material Management	3		
Tool Room / Bench Stock			
Shops	30	1,800	Net SF
Electrical	3		
Power Production	3		
HVAC	4		
Pavements	6		
Structures	2		
Utilities, Plumbing / Water / Waste	4		
Structural	8		
Subtotal		2,610	Net SF
15% Overhead		392	
Subtotal		3,002	
Functional Standard		3,000	Gross SF

7.25.6 Base Civil Engineering Maintenance Shop, FTIG & JCSS

Table 7-43: CATCODE 219-944, BCE Maint Shop, FTIG & JCSS

Major Functions & Breakouts	Authorized Staffing	Target Area (SF)	Remarks
Administration	2	375	Net SF
Production / Work Control	1		
Building Maintenance Foreman	1		
Tool Room / Bench Stock			
Shops	7	420	Net SF
Electrical	1		
HVAC	1		
Pavements & Grounds	1		
Structures	1		
Utilities, Plumbing / Water / Waste	1		
Custodial Workers	2		
Storage	0	84	Net SF
Mobility Equip Storage			
PPE Training Bag Storage			
Subtotal		879	Net SF
15% Overhead		132	
Subtotal		1,011	
Functional Standard		1,000	Gross SF

7.25.7 Prime Power Maintenance Shop, Designated Units

Table 7-44: CATCODE 219-944, Prime Power Maint Shop, Designated Units

Major Functions & Breakouts	Authorized Staffing	Target Area (SF)	Remarks
Administration	1	64	Net SF
Superintendent	1		
Shops	14	1,212	Net SF
Elect System Craftsman / Journeyman	6		
Power Pro Craftsman / Journeyman	8		
Shop			
Maintenance Shop / Tool Area			
Subtotal		1,276	Net SF
15% Overhead		191	
Subtotal		1,467	
Functional Standard		1,500	Gross SF

7.25.8 Base Civil Engineering Maintenance Shop, ANGR CAMPUS

Table 7-45: CATCODE 219-944, BCE Maint Shop, ANGR CAMPUS

Major Functions & Breakouts	Authorized Staffing	Target Area (SF)	Remarks
Administration	2	375	Net SF
Production Control	1		
Work Leader	1		
Tool Room / Bench Stock			
Shops	12	720	Net SF
Electrical Craftsman	1		
HVAC Technician	2		
Pavements & Grounds Maintenance	2		
Custodial Workers	4		
Custodial Workers	3		
Subtotal		1,095	Net SF
15% Overhead		164	
Subtotal		1,259	
Functional Standard		1,300	Gross SF

7.26 CATCODE 219-947, Base Civil Engineer Storage Shed

This facility is a one, two or three sided roofed structure with no expectation to have doors and fire protection with Gross SF as full scope thus 1,000SF BE Storage Shed counts as 1,000SF because the un-enclosed shed is the intended purpose. Do not count as half scope and build double the size. This covered space provides storage space and related operating space for the supplies and material used by the BCE organization in its day-to-day activities of operating, maintaining and constructing facilities which do not require regular warehouse storage yet must be protected from the weather. Example: To store sand and/or salt for winter roads or snow plows.

Table 7-46: CATCODE 219-947, BCE Storage Shed

Mission	Functional Standard (Gross SF)	Remarks
Prime – Base Engineer Emergency Force (Prime BEEF)	4,000	
1/2 RED HORSE Sqd	9,000	
1/4 RED HORSE Sqd	6,800	
CRTC	5,000	
ANGRC Campus	4,500	1,000 SF enclosed & 3,500 SF covered
Prime Power	1,000	
GSU / Aircraft Ranges	1,000	
MEOC	1,000	See note 3: CATCODE 610-913, Emergency Management (EM)

Figure 7-20: CATCODE 219-947, BCE Storage Shed example images



B1003

Chapter 8: Category Group 31 – RDTE Buildings

8.1 General Criteria

Research, Development, Test, and Evaluation (RDT&E) facilities support operational and developmental test and evaluation and tactics development and evaluation for all Air Reserve Component's (ARC) weapons systems. Facilities at an installation will vary with mission assigned, operational space needs, and assigned personnel to include contractors.

8.2 CATCODE 311-114, Aircraft Dynamic Research Engineering Facility

8.2.1 Description. Facility designed for integration research, development and testing of Air Reserve Component's (ARC) weapons systems.

8.2.2 Functional Standard for this facility requires NGB/A4F approval based on number of UMD and contractor personnel along with operational needs. Current ANG RTDE Buildings like AATC have been defined through individual requests and NGB/A4F approval which is reflected on the 920.

Chapter 9: Category Group 42 – Explosive Facilities

9.1 General Criteria

The quantity and type of explosives storage facilities at an installation will vary with operating requirements, tasked Unit Type Codes (UTC), War Reserve Material (WRM), the quantity and type of munitions to be stored or handled, site characteristics, and the type of storage structures preferred (or required) at the storage site. Consider both aircraft mission and base support mission. Base support missions could include but not limited to; EOD, Air to Ground Ranges, Regional Explosive Storage, Joint base multi DOD component munitions storage and Special Tactics Units.

9.2 CATCODE 422-258, Above Ground Multi-Cubicle Magazine Storage

An Above Ground Magazine (AGM) provides the user multiple separated storage bays in one structure, doors normally facing out. Explosive Quantity Distance Siting must be IAW DESR 6055.09_AFMAN91-201. If there is not already an approved drawing identified in the TP 15, Approved Protective Construction, a proper engineering analysis must be completed to provide compatibility protection between bays. UFC 4-010-01 provides Minimum Antiterrorism Standards for buildings. AFJMAN 32-1071 Provides Minimum Force protection requirements, and DoDI 5100.76, provides requirements for *Safeguarding Sensitive Conventional Arms, Ammunition, and Explosives (AA&E)*. The preferred method of explosive storage is an Earth Covered Magazine (ECM) per the DESR par. V1.E6.34.1. Ground support equipment is stored in the Conventional Munitions Shop ([CATCODE 216-642, Conventional Munitions Shop](#)).

Table 9-1: CATCODE 422-258, Above Ground Multi-Cubicle Magazine Storage

Aircraft / Mission	Functional Standard (Gross SF)
Tanker / Airlift (includes WRM)	1,800
F-15, F-16, F-35, F-22 & MQ-9	6,140
A-10	7,240
Aerospace Sovereignty Alert (ASA) "detached" alert only	2,900
MQ-1	1,800
Air Rescue Wing	2,500
CRTC	2,000
RED HORSE, CRG & EOD	800
Aircraft Range	600

NOTE:

1. Check with Munitions FAM at NGB/A4 for further information.

9.3 CATCODE 422-264, Storage Igloo

Earth Covered Magazines (ECM) also known as “igloos” is preferable for all types of explosives. From an explosives safety and reliability standpoint, give priority to the use of ECMs for items requiring protection from the elements, long-term storage, or high security protection. ECM is an aboveground, earth-covered structure that meets soil cover depth and slope requirements per the DESR 6055.09_AFMAN91-201 . ECMs have three possible strength designations: 7-Bar, 3-Bar, or Undefined. The strength of an ECM’s headwall and door determines its designation. Explosive Quantity Distance Siting must be IAW DESR 6055.09_AFMAN91-201. UFC 4-010-01 provides Minimum Antiterrorism Standards for buildings. AFJMAN 32-1071 Provides Minimum Force protection requirements. DoDI 5100.76 provides requirements for *Safeguarding Sensitive Conventional Arms, Ammunition, and Explosives (AA&E)*. Less hazardous munitions can be store in above ground magazines identified in [CATCODE 422-258, Storage Magazine Above Ground](#)

Table 9-2: CATCODE 422-264, Storage Igloo

Aircraft / Mission	Functional Standard (Gross SF)
Tanker / Airlift (for WRM)	Submit to FAM for need to coordinate with A4F for Target Area
MC-130J, 193 SOW	1,800
MQ-9	3,600
General Purpose Fighter	3,600
F-15EX	4,000
Air-To-Air or ASA	8,600
Rescue Wing	4,680
CRTC	3,600

Figure 9-1: CATCODE 422-264, Storage Igloo example, used for F-15EX

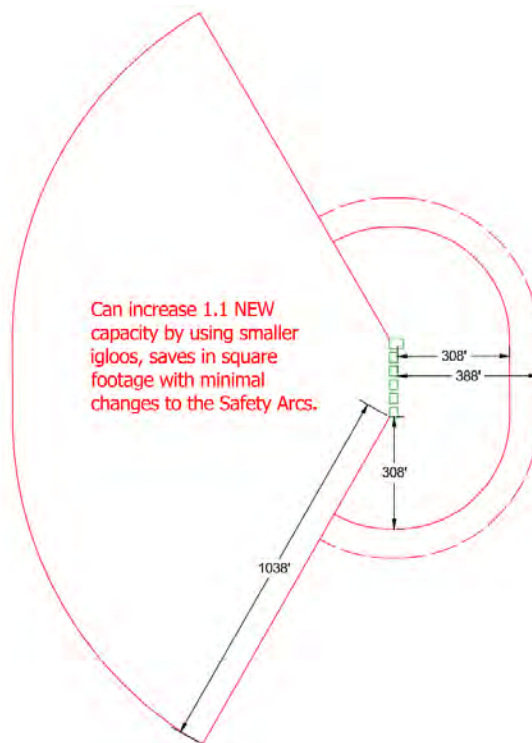

9.4 **CATCODE 422-275, Ancillary Explosives Facility**

- 9.4.1 This designation may be applied to concrete pads, revetments, and facilities such as classification yard, holding yard, inspection station, interchange yard, loading dock, ready explosives facility and bomb preload station. Use for Munitions Assembly Conveyor (MAC) [AKA Rapid Assembly Munitions System (RAMS)] pad. **There is no facility covering for MAC/RAMS pads.**
- 9.4.2 Will not be part of the aircraft apron because apron pavement is of higher Replacement Unit Costs (RUC) and Sustainment Unit Costs (SUC) and the AF description excludes aircraft apron.

Chapter 10: Category Groups 44, 45 – Storage Facilities: Covered, Open, Special Purpose

10.1 General Criteria

10.1.1 Storage facilities provide space to keep, service, dispense, and dispose of a myriad of goods and materials. Existing space in this category can be optimized through the procurement of material handling equipment.

10.1.2 Each spring Air Force Mobility Command - Logistics Support Office/Logistics Engineering (AFMC-LSO/LOE), Wright-Patterson AFB, OH, requests desired evaluations, site visits, and procurement of new material handling systems from the field. Industrial Engineers from Wright-Patterson will visit your base and perform unit funded temporary duty (TDY) evaluations of existing systems and facilities. They will then program the procurement of replacement equipment. All requests for assistance should be routed through NGB/A4RMS, Superintendent Policy and Procedures. When constructing new facilities it is highly recommended that AFMC-LSO/LOE be involved in the planning and design process to maximize efficiency of design, type and placement of materials handling equipment, and placement of utilities to support materials handling equipment.

10.2 CATCODE 442-257, Base Hazardous Materials Storage

10.2.1 This Standard provides properly configured space to store hazardous materials prior to their use, as well as the temporary storage of hazardous waste before proper disposal.

10.2.2 Hazardous Materials (HAZMAT) Pharmacy. Each installation is required to establish a HAZMAT pharmacy program to positively control the procurement, storage, distribution, reuse, and disposal of identified hazardous items such as paints, oil, solvents, corrosives, other chemicals, and bottled gases. Tenant ANG units with a host-provided HAZMAT pharmacy are not authorized a separate facility.

Table 10-1: CATCODE 442-257, HAZMAT Pharmacy

Aircraft / Mission	Functional Standard (Gross SF)
Flying Units, CRTC's & RPA (main base)	1,800
RPA (LRE)	500
GSU	300
1/2 RED HORSE Sqd	600
1/4 RED HORSE Sqd and Aircraft Range	300
Special Tactics Squadron	300

10.2.3 Hydrazine Storage and Servicing Facility: Provides space for the regional servicing and storage of hydrazine fuel containers at installations with F-16 aircraft equipment emergency power units that operate on hydrazine; 800 Gross SF is authorized.

1 10.2.4 Hydrazine Storage Facility: Provides space for the storage of hydrazine fuel containers with
2 no servicing requirement at installations with F-16 aircraft equipment emergency power
3 units that operate on hydrazine; 200 Gross SF is authorized.

4 10.2.5 Central Hazardous Waste Accumulation Point: Includes the central hazardous waste
5 collection point. Satellite collection is addressed by the facility that generates the hazardous
6 waste. The central collection point is usually a concrete pad, [CATCODE 132-133,](#)
7 [Equipment Pad](#) , with utilities, upon which to mount a commercially available, prefabricated
8 shed (not Real Property) for the storage of small amounts of hazardous waste until they are
9 removed / manifested from the base.

10

10.3 CATCODE 442-258, Cryogenics (LOX / LIN) Storage

10.3.1 All bases or CRTC's with a requirement for liquid oxygen (LOX) for aircrews' breathing purposes will possess a LOX generating / storage capability or a LOX storage capacity to satisfy the requirement. The decision to rely on a generating/storage capability or on storage capacity and commercial suppliers will be based on individual base analyses to determine the best procedure to ensure meeting the requirements of each base.

10.3.2 The normal source for breathable LOX within the United States, its territories, and possessions will be by procurement from commercial suppliers wherever they are available to meet quantity and specification requirements. In these instances, base storage capacity will be sufficient to provide 30 days' peacetime requirement or 15 days' 'alert', whichever is greater, plus (WRM) and enough storage to permit receipt of supplies in economical quantities from suppliers.

10.3.3 In every instance, a minimum of at least two tanks (which are centrally procured equipment items) will be provided in multiples of 400, 2,000, or 5,000 gallons, respectively to ensure continuous operation and permit periodic purging and decontamination of the tanks.

10.3.4 LOX storage facilities require fencing for safety protection.

10.3.5 See AFI 23-201, *Fuels Management* and Air Mobility Command (AMC) for liquid nitrogen (LIN) storage facility design requirements. Provide canopies over tank(s) in areas of snow and ice to ensure safe footing for personnel, and in areas of extremely hot weather to minimize boil-off losses.

1 10.4 **CATCODE 442-628, Base Supply and Equipment Shed**

2 This facility is an unheated covered storage shed with walls on three sides designed for storage of
 3 equipment and materials that may be stored in open but covered space. Lumber storage exclusive
 4 of that stored by the Base Civil Engineer (BCE) may also be included, as may be space for
 5 receiving and shipping activities. (see table on next page)

6 **Table 10-2: CATCODE 442-628, Base Supply and Equipment Shed**

Mission	Functional Standard (Gross SF)
Special Operations Weather Team (SOWT)	1,100
Flying Units	2,500
REOTS	5,000
Joint Communications Support Squadron (JCSS)	5,400
Lightning Force Academy (LFA)	6,000
Air Control Squadrons (ACS)	6,000
CRTC	8,000
1/2 RED HORSE Sqd	8,400
1/4 RED HORSE Sqd	6,200
Special Tactics Squadron (STS)	14,582
CE Regional Training Site (RTS)	21,600

7
 8

10.5 CATCODE 442-758, Base Supply and Equipment Warehouse

10.5.1 Warehouse functions include bulk and bin storage of materials, receiving, shipping, packing, crating, equipment storage and issue, general supply, courtesy storage, and base issue supply point. Courtesy warehouse storage space will be provided to other units and functions on base when space is available in the supply warehouse.

10.5.2 Space for mobility storage not identified elsewhere is included in this facility or separate one(s); however, space will not be duplicated. This mobility storage is used for installation’s deployable personal mobility equipment and ready to issue deployment mobility bags. Only the warehouse storage space is to be designed with a high roof. Other functions such as receiving, shipping, packing, and crating can be performed under a 12 ft. high roof area.

10.5.3 Storage space for base defense weapons, chaff, Defense Reutilization Marketing Office (DRMO) holding area, firefighting agents, WRM oils, Chemical Warfare Defense equipment, base decontaminants, base level self-sufficiency spares, and special projects.

10.5.4 The total scope of the host base supply facility may be increased by 1,000 Gross SF per GSU or other unit with a maximum of 3,000 Gross SF added when the warehouse is required to support either other units on base or geographically separated units (GSUs) that have a separate mission but receive supply support from the host base.

10.5.5 Normally collocated with [CATCODE 610-122, Base Supply Administration](#)

Table 10-3: CATCODE 442-758, Base Supply and Equipment Warehouse

Aircraft / Mission	Functional Standard (Gross SF)	Remarks
Fighter Aircraft	21,200	Note 1
RPA (MCE)	7,500	Note 2 & Note 3
RPA (LRE)	7,000	Note 2
MC-12	17,600	
C-130, KC-135	17,900	
C-17	28,200	
KC-46	21,600	
Air Control Squadron (ACS)	13,600	
Air Support Operations Squadron (ASOS)	2,600	
Air Traffic Control Squadron (ATCS)	7,000	
Combat Communications Group (CCG)	2,200	Additive for collocated units
Combat Communications Squadron (CCS)	13,600	Additive for collocated units
Contingency Response Group, 160 personnel	9,000	
Engineering Installation Squadron (EIS)	7,000	
Information Warfare Aggressor Squadron (IWAS)	2,300	Mobility Bags
Regional Equipment Operators Training Site (REOTS)	5,000	
1/2 RED HORSE Sqd	12,800	

Aircraft / Mission	Functional Standard (Gross SF)	Remarks
1/4 RED HORSE Sqd	8,400	
Combat Readiness Training Center (CRTC)	18,000	
EMEDS-CM Medical Equipment Storage	3,400	Formerly known as CERFP-HRF
Disaster Relief Beddown Set (DRBS) Equipment Storage	8,000	Storage for 2 kits, double stacked
EMEDS Equipment Storage	32,000	
Combat (Battlefield) Weather Flight	3,700	
Special Operations Weather Team (SOWT)	3,600	
Security Forces Operations, Stand Alone	2,500	
Security Forces Operations, Collocated	2,000	
Special Tactics Squadron (STS)	8,693	
Fatality Search & Recovery Team (FSRT) Storage	2,000	
RPA Field Training Detachment (FTD)	9,700	This is distinct and separate from space provided to the operational RPA mission.
Joint Communications Support Squadron (JCSS)	8,000	

NOTE:

1. Add 1,100 Gross SF to F-22 and F-35 for mobility storage.
2. MQ-1 / MQ-9 are authorized an additional 650 SF per aircraft to provide space for Casket Storage. Authorization will be split between the main operating location and the Launch Recovery Element (LRE). Storage space should be collocated with or near [CATCODE 211-111, Maintenance Hangar](#). Existing excess Maintenance Hangar space can be used to meet this requirement, but Maintenance Hangar space will not be specifically constructed for Casket Storage.
3. If the RPA MCE is located at an installation with a manned flying mission, then the Functional Standard will be reduced from 7,500 SF to 1,200 SF.

1
 2
 3
 4
 5
 6
 7
 8
 9
 10

1 10.6 **CATCODE 452-252, Base Supply Open Storage**

2 10.6.1 A paved area used to store materials that can withstand exposure to the elements. Exterior
3 lights and fencing should be installed as required to deter theft. The **600 SY** open storage
4 area is usually part of the Base Supply complex.

5 10.6.2 Any unit or mission that requires [CATCODE 442-758, Base Supply and Equipment](#)
6 [Warehouse](#) will probably also require this CATCODE, but only one set of these
7 CATCODEs is required per installation.

8 10.7 **CATCODE 452-255, Base Civil Engineer Open Storage**

9 10.7.1 The BCE activity consists of paved open storage space for construction materials and
10 equipment that can withstand exposure to the elements. Exterior lights and fencing may be
11 installed as required to deter theft. This facility is part of the BCE complex consists of an
12 improved or paved area large enough to accommodate the required amount of materials and
13 equipment, but the space must not exceed **3,600 SY**.

14 10.7.2 A Civil Engineer unit or mission requires either [CATCODE 219-947, Base Civil Engineer](#)
15 [Storage](#) or [CATCODE 452-255, Base Civil Engineer Open Storage](#), but only one set of
16 these CATCODEs will be authorized per installation unless operationally required to have
17 both. If operationally required to have both, the unit must request approval to NGB/A4F.

18

Chapter 11: Category Group 61 – Administrative Facilities

11.1 General Criteria

Administrative space requirements normally include private offices (supervisory), conference / training space, open office areas (staff), administrative support areas (reproduction, workspace, files storage, publications / technical libraries), and receiving areas.

11.2 CATCODE 610-121, Vehicle Operations Administration

11.2.1 This facility is required for the management, operation and control of Government Operated Vehicles (GOV) fleet.

11.2.2 The facility includes vehicle management offices and administrative space, dispatch office, driver evaluation / testing / licensing, production control, training room / vehicle licensing room / driver's ready room / break area, T.O. / library / vehicle records keeping section, and personal lockers. The facility must be collocated with the [CATCODE 214-425, Vehicle Maintenance Shop](#) and [CATCODE 852-261, Vehicle Parking Operations](#).

Table 11-1: CATCODE 610-121, Vehicle Operations Admin

Major Functions & Breakouts	Authorized Staffing	Target Area (SF)	Remarks
Maintenance Superintendent	1		
Training & Testing			See Chapter 1
Conference & Meeting			See Chapter 1
Administration	1		
T.O. / Library	1		
Vehicle Maintenance Supervisor	1		
Production Control	2		
Vehicle Operations Supervisor	1		
Vehicle Dispatcher	2		
Break Room			
PPE Training Bag Storage			
Subtotal		1,381	Net SF
10% Circulation		138	
25% Overhead		380	
Subtotal		1,899	
Functional Standard	9	1,900	Gross SF

NOTES:

1. This facility also supports personnel assigned to the Vehicle Maintenance Shop.
2. Functional standard for Aircraft Ranges is 300 Gross SF.
3. Functional standard for other GSU's and RED HORSE is 700 Gross SF.

11.3 CATCODE 610-122, Base Supply Administration

11.3.1 Base supply administrative functions include the commander, management and systems, material management, operations support, supply customer training, Traffic Management Office (TMO), and orderly room.

11.3.2 This function intended to be collocated with [CATCODE 442-758, Base Supply and Equipment Warehouse](#).

11.3.3 Base Supply Administration, Flying Unit, 43 Personnel

Table 11-2: CATCODE 610-122, Base Supply Admin, Flying Unit, 43 Personnel

Major Functions & Breakouts	Authorized Staffing	Target Area (SF)	Remarks
Command & Administration	5	1,102	Net SF
Commander	1		
First Sergeant	1		
Training & Testing			See Chapter 1
Conference & Meeting			See Chapter 1
Orderly Room / Administration	3		
Operations & Training	37	2,280	Net SF
Operations Compliance Superintendent	1		
Quality Assurance (QA) Manager	1		
Quality Assurance Evaluator(s)	2		IAW AFI 20-112_2.1.2. LRS QA Baseline Structure. No < 3 pers
Training Manager / UDM	1		
Functional Systems Management	1		Required for the storage & repair of computers for LRS
Resource Management	1		
Material Management Flight NCOIC	1		
Customer Support Section NCOIC	1		
Equipment Accountability Element	1		
Customer Support Liaison Element	1		
Maintenance Support Section NCOIC	1		
Maintenance Support Liaison Element	2		
Flight Service Center Element	2		
Asset Management Section NCOIC	1		
Aircraft Parts Store Element	2		
Central Storage Element	3		
Individual Protective Equipment Element	3		
Hazardous Material Element	2		
Individual Equipment Element	2		
Traffic Manager / Superintendent	1		
Transportation Assistant	1		
Passenger Travel	1		
SATO / CTO	1		
Logistics Plans	5	432	Net SF
Installation Deployment Officer	1		
Superintendent of Logistics Plans	1		
Logistics Planner	2		
Installation Personnel Readiness	1		
Support	0	165	Net SF
Break Area			

PPE Training Bag Storage			
Subtotal		3,979	Net SF
25% Overhead		995	
Subtotal		4,974	
Functional Standard		5,000	Gross SF

- 1 NOTES:
 2 1. This function is intended to be collocated with [CATCODE 442-758, Base Supply and Equipment Warehouse](#)
 3 2. Add 150 Gross SF for “Operations Officer” and 150 Gross SF for “Squadron Superintendent” if these positions
 4 are funded locally (IAW ANG P-PLAN 08-01).
 5

11.3.4 Base Supply Administration, KC-135, Two Flying Squadrons, 47 Personnel

Table 11-3: CATCODE 610-122, Base Supply Admin, KC-135 Two Flying Sqdns, 47 Personnel

Major Functions & Breakouts	Authorized Staffing	Target Area (SF)	Remarks
Command & Administration	6	1,166	Net SF
Commander	1		
First Sergeant	1		
Training & Testing			See Chapter 1
Conference & Meeting			See Chapter 1
Orderly Room / Administration	4		
Operations & Training	36	2,840	Net SF
Operations Compliance Superintendent	1		
Quality Assurance (QA) Manager	1		
Quality Assurance Evaluators	3		
Training Manager / UDM	1		
Functional Systems Management	1		
Resource Management	1		
Material Management Flight NCOIC	1		
Customer Support Section NCOIC	1		
Equipment Accountability Element	2		
Customer Support Liaison Element	2		
Maintenance Support Section NCOIC	1		
Maintenance Support Liaison Element	2		
Flight Service Center Element	2		
Asset Management Section NCOIC	1		
Aircraft Parts Store Element	2		
Central Storage Element	3		
Individual Protective Equipment Element	3		
Hazardous Material Element	2		
Individual Equipment Element	2		
Traffic Manager / Superintendent	1		
Transportation Assistant	1		
Passenger Travel	1		
SATO / CTO	1		
Support	5	432	Net SF
Installation Deployment Officer	1		
Superintendent of Logistics Plans	1		
Logistics Planner	2		
Installation Personnel Readiness	1		
Support	0	171	Net SF
Break Area			
PPE Training Bag Storage			
Subtotal		4,297	Net SF
25% Overhead		1,074	
Subtotal		5,371	
Functional Standard		5,400	Gross SF

NOTES:

1. This function is intended to be collocated with [CATCODE 442-758, Base Supply and Equipment Warehouse](#).
2. Add 150 Gross SF for “Operations Officer” and 150 Gross SF for “Squadron Superintendent” if these positions are funded locally (IAW ANG P-PLAN 08-01).

11.3.5 Base Supply Administration, Non-Flying Unit, 18 Personnel

Table 11-4: CATCODE 610-122, Base Supply Admin, Non-Flying Unit, 18 Personnel

Major Functions & Breakouts	Authorized Staffing	Target Area (SF)	Remarks
Command & Administration	2	564	Net SF
Commander	1		
Training & Testing			See Chapter 1
Conference & Meeting			See Chapter 1
Orderly Room / Administration	1		
Operations	11	816	Net SF
Munitions	2		
Operations Compliance Superintendent	1		
Operations Compliance Flight	3		
Material Management Flight NCOIC	1		
Customer Support / Asset Management	2		
Traffic Management	2		
Logistics Plans	5	432	Net SF
Installation Deployment Officer	1		
Superintendent of Logistics Plans	1		
Logistics Planner	2		
Installation Personnel Readiness	1		
Support	0	120	Net SF
Break Area			
PPE Training Bag Storage			
Subtotal		1,939	Net SF
25% Overhead		485	
Subtotal		2,424	
Functional Standard		2,400	Gross SF

NOTES:

1. This function is intended to be collocated with [CATCODE 442-758, Base Supply and Equipment Warehouse](#).
2. Add 150 Gross SF for "Operations Officer" if this position is funded locally (IAW ANG P-PLAN 08-01).

1 11.3.6 Base Supply Administration, CRTTC, 9 Personnel

2 **Table 11-5: CATCODE 610-122, Base Supply Admin, CRTTC, 9 Personnel**

Major Functions & Breakouts	Authorized Staffing	Target Area (SF)	Remarks
Material Management Superintendent	1		
Training & Testing			See Chapter 1
Conference & Meeting			See Chapter 1
Administration / Storage			
Hazardous Material Element	1		
Customer Support Section	2		
Asset Management Section	3		
Logistics Plans	2		
Break Area			
Subtotal		1,128	Net SF
25% Overhead		297	
Subtotal		1,484	
Functional Standard		1,500	Gross SF

3

4

11.3.7 Base Supply Administration, GSU and 1/2 RED HORSE Squadron, 7 Personnel

Table 11-6: CATCODE 610-122, Base Supply Admin, GSU and 1/2 RED HORSE Sqd, 7 Prsnl

Major Functions & Breakouts	Authorized Staffing	Target Area (SF)	Remarks
Superintendent	1		
Conference & Meeting			See Chapter 1
Administration / Storage			
Logistics Plans	2		
Customer Support / Asset Mgt Specialist	4		
Subtotal		864	Net SF
10% Overhead		86	
Subtotal		950	
Functional Standard		1,000	Gross SF

NOTES:

1. This function is intended to be collocated with another function, not a standalone facility.
2. Dedicated Break area, Training and Testing and PPE Training Bag Storage space not required, function is collocated and those areas are already accounted for in the parent organization.

11.3.8 Base Supply Administration, 1/4 RED HORSE Squadron, 4 Personnel

Table 11-7: CATCODE 610-122, Base Supply Admin, 1/4 RED HORSE Sqd, 4 Personnel

Major Functions & Breakouts	Authorized Staffing	Target Area (SF)	Remarks
Superintendent	1		
Conference & Meeting			See Chapter 1
Administration / Storage			
Logistics Plans	1		
Customer Support / Asset Mgt Specialist	2		
Subtotal		672	Net SF
10% Overhead		67	
Subtotal		739	
Functional Standard		750	Gross SF

NOTES:

3. This function is intended to be collocated with another function, not a standalone facility.
4. Dedicated Break area, Training and Testing and PPE Training Bag Storage space not required, function is collocated and those areas are already accounted for in the parent organization.

1
2
3
4
5

11.4 **CATCODE 610-123, General Administrative Building**

In the ANG, this function typically provides administrative space to support aircraft maintenance contractor personnel.

11.5 CATCODE 610-127, Base Civil Engineer Administration

11.5.1 This function contains the principal administrative offices of the BCE organization, such as the Commander / BCE’s office, the deputy BCE’s office, areas for squadron administration, Environmental Management, engineering, operations, resources, and other functions. Also contains a drafting / CAD area, conference / training rooms, and various administrative support areas.

11.5.2 Collocated with [CATCODE 219-944, Base Civil Engineer Maintenance Shop](#)

11.5.3 Base Civil Engineer Administration, Flying Unit with Prime BEEF Team

Table 11-8: CATCODE 610-127, BCE Admin, Flying Unit with Prime BEEF Team

Major Functions & Breakouts	Authorized Staffing	Target Area (SF)	Remarks
Command & Administration	7	2,059	Net SF
Commander / Base Civil Engineer (BCE)	1		
Training & Testing			See Chapter 1
Conference & Meeting			See Chapter 1
First Sergeant	1		
Orderly Room Administration	1		
Training Manager	1		Includes storage space
Staff Officer / Real Property	1		
Environmental Manager	1		Includes storage space
Resource Advisor	1		Includes storage space
Operations	6	1,589	Net SF
Operations Officer / Deputy BCE	1		Includes storage space
Chief of Operations / Facility Manager	1		
Engineering Officer	1		
Drafting / CADD	1		
Reproduction / Plans / Storage			
Engineering	2		
Support	0	190	Net SF
Break Area			
PPE Training Bag Storage			
Subtotal		3,838	Net SF
25% Overhead		960	
Subtotal		4,798	
Functional Standard		4,800	Gross SF

NOTE:

- This function should be collocated with [CATCODE 219-944, Base Civil Engineer Maintenance Shop](#).

1

2

Table 11-9: CATCODE 610-127, BCE Admin, Flying Unit w/o Prime BEEF Team

Major Functions & Breakouts	Authorized Staffing	Target Area (SF)	Remarks
Command & Administration	6	1,173	Net SF
Commander / Base Civil Engineer (BCE)	1		
Training & Testing			See Chapter 1
Conference & Meeting			See Chapter 1
Orderly Room Administration	2		
Real Property	1		Includes storage space
Environmental Manager	1		Includes storage space
Resource Advisor	1		Includes storage space
Operations	4	1,525	Net SF
Deputy BCE	1		
Facility Manager	1		
Engineering	1		
Drafting / CADD	1		
Reproduction / Plans / Storage			
Support	0	14	
Break Area			
PPE Training Bag Storage			
Subtotal		2,712	Net SF
25% Overhead		678	
Subtotal		3,390	
Functional Standard		3,400	Gross SF

3

4

5

6

NOTE:

1. This function intended to be collocated with [CATCODE 219-944, Base Civil Engineer Maintenance Shop](#).

11.5.4 Base Civil Engineer Administration, S-Team: The Civil Engineering Flight (CEF) S-Team (Staff Augmentation Team) is a specialty engineering force used to provide Unified Commands, MAJCOM, Numbered Air Force, or Combined / Joint Task Force command staff augmentation for engineer management, technical design, construction management, command and control, and reporting in support of regional contingencies. The space is generally administrative in nature with some teaming areas for projects and storage for deployable equipment.

Table 11-10: CATCODE 610-127, BCE Admin, S-Team, 25 Personnel

Major Functions & Breakouts	Authorized Staffing	Target Area (SF)	Remarks
Command & Administration	5	868	Net SF
Commander	1		
Vice Commander	1		
Training & Testing			See Chapter 1
Conference & Meeting			See Chapter 1
Administrative Section	2		
Prime BEEF Manager	1		
Operations	20	1,480	Net SF
Flight Work Area	20		20 work stations
Reproduction / Plans / Storage			
Support	0	136	Net SF
Break Area			
PPE Training Bag Storage			
Subtotal		2,484	Net SF
25% Overhead		621	
Subtotal		3,105	
Functional Standard		3,100	Gross SF

NOTE:

1. Provides space for 25 personnel: Two twelve (12) person S-6 Teams and 1 full-time Prime BEEF Manager.

11.5.5 Base Civil Engineer Administration, S-Team, 40 Personnel

Table 11-11: CATCODE 610-127, BCE Admin, S-Team, 40 Personnel

Major Functions & Breakouts	Authorized Staffing	Target Area (SF)	Remarks
Command & Administration	7	1,342	Net SF
Commander	1		
Vice Commander	2		
Training & Testing			See Chapter 1
Conference & Meeting			See Chapter 1

Major Functions & Breakouts	Authorized Staffing	Target Area (SF)	Remarks
Administrative Section	3		
Prime BEEF Manager	1		
Operations	33	2,412	Net SF
Flight Work Area	33		33 workstations
Reproduction / Plans / Storage			
Support	0	159	Net SF
Break Area			
PPE Training Bag Storage			
Subtotal		3,913	Net SF
25% Overhead		978	
Subtotal		4,891	
Functional Standard		4,900	Gross SF

- 1 NOTE:
 2 1. Provides space for 40 personnel: Three twelve (12) person S-6 teams, 1 three (3) person S-4 team, and one full-
 3 time Prime BEEF Manager.
 4

1 11.5.6 Base Civil Engineer Administration, CRTC, 10 Personnel

2 **Table 11-12: CATCODE 610-127, BCE Admin, CRTC, 10 Personnel**

Major Functions & Breakouts	Authorized Staffing	Target Area (SF)	Remarks
Command & Administration	6	1,432	Net SF
Commander / Base Civil Engineer (BCE)	1		
Training & Testing			See Chapter 1
Conference & Meeting			See Chapter 1
Orderly Room Administration	1		
Real Property	1		Includes storage space
Environmental Management	2		Includes storage space
Resource Advisor	1		Includes storage space
Operations	4	1,320	Net SF
Deputy BCE / Operations Officer	1		
Facility Manager	1		
Engineering	1		
Drafting / CADD	1		
Reproduction / Plans / Storage			
Support	0	100	Net SF
Break Area			
Subtotal		2,852	Net SF
25% Overhead		713	
Subtotal		3,565	
Functional Standard		3,600	Gross SF

3

4

11.5.7 Base Civil Engineer Administration, Base Operating Support w/o Prime BEEF, 7 Personnel

Table 11-13: CATCODE 610-127, BCE Admin, BOS w/o Prime BEEF, 7 Personnel

Major Functions & Breakouts	Authorized Staffing	Target Area (SF)	Remarks
Command & Administration	5	1,089	Net SF
Commander / BCE	1		
Training & Testing			See Chapter 1
Conference & Meeting			See Chapter 1
Orderly Room Administration	1		
Real Property	1		Includes storage space
Resource Advisor	1		Includes storage space
Environmental Management	1		Includes storage space
Operations	2	440	Net SF
Facility Manager	1		
Engineering, Construction Manager	1		
Drafting Work station / Reproduction / Plans Storage			
Support	0	100	Net SF
Break Area			
Subtotal		1,629	Net SF
25% Overhead		407	
Subtotal		2,036	
Functional Standard		2,000	Gross SF

NOTE:

- This function is intended to be collocated with FTIG [CATCODE 219-944, Base Civil Engineer Maintenance Shop](#).

1 11.5.8 Base Civil Engineer Administration, ANGRC Campus, 5 Personnel

2 **Table 11-14: CATCODE 610-127, BCE Admin, ANGRC CAMPUS, 5 Personnel**

Major Functions & Breakouts	Authorized Staffing	Target Area (SF)	Remarks
Command & Administration	3	739	Net SF
Base Civil Engineer	1		
Training & Testing			See Chapter 1
Conference & Meeting			See Chapter 1
Orderly Room Administration	1		
Real Property / Resource Advisor	1		Includes additional space for storage
Operations	2	184	Net SF
Facility Manager	1		
Maintenance Supervisor	1		
Support	0	100	Net SF
Break Area			
Subtotal		1,023	Net SF
25% Overhead		256	
Subtotal		1,279	
Functional Standard		1,300	Gross SF

3 NOTE:

4 1. This function is intended to be collocated with [CATCODE 219-944, Base Civil Engineer Maintenance Shop](#).

5

11.6 CATCODE 610-129, Weapons Systems Maintenance Management (WSMM)

11.6.1 Houses the administrative areas of the Maintenance Group, includes the following functions: chief of maintenance and administrative staff; maintenance control; material control; plans; scheduling, and documentation; and quality control, records, and analysis.

11.6.2 Weapons Systems Maintenance Management (Fighter Aircraft), 67 Personnel

Table 11-15: CATCODE 610-129, Weapons Sys Maint (Fighters), 67 Personnel

Major Functions & Breakouts	Authorized Staffing	Target Area (SF)	Remarks
Command & Administration	22	2,042	Net SF
Group Commander	1		
Deputy Commander	1		
Executive Officer	1		
Training & Testing			See Chapter 1
Conference & Meeting			See Chapter 1
Orderly Room / Administration	2		
Quality Assurance Manager	1		
Quality Assurance Supervisor	1		
Quality Assurance	10		
Weapons Standards Manager	1		
Weapons Standards Supervisor	1		
Weapons Standards Personnel	3		
Maintenance Squadron	9	800	Net SF
Commander	1		
Orderly Room / Administration	3		
First Sergeant	1		
Maintenance Officer	1		
Maintenance Manager	1		
Maintenance Superintendent	1		
Maintenance Supervisor	1		
Aircraft Maintenance Squadron Section	11	872	Net SF
Commander	1		
Orderly Room / Administration	3		
First Sergeant	1		
Maintenance Officer	1		
Maintenance Manager	1		

Major Functions & Breakouts	Authorized Staffing	Target Area (SF)	Remarks
Maintenance Supervisor	2		
Maintenance Personnel	2		
Maintenance Operations Flight	25	1,924	Net SF
Commander	1		
Orderly Room / Admin	2		
Superintendent	1		
Maintenance Analysis	4		
Maintenance Operations Center Manager	1		
Maintenance Operations Center	5		
Planning, Scheduling & Documentation Manager	1		
Planning, Scheduling, & Documentation	5		
T.O. Library & Distribution Center			
Training Manager	2		
Training Personnel	2		
Plans & Resources	1		
Support	0	202	Net SF
Break Room			
PPE Training Bag Storage			
Subtotal		5,840	Net SF
25% Overhead		1,460	
Subtotal		7,300	
Functional Standard		7,300	Gross SF

1
 2
 3

11.6.3 Weapons Systems Maintenance Management (F-35 w/o Contractors), 74 Personnel

Table 11-16: CATCODE 610-129, Weapons Sys Maint (F-35 w/o Contractors), 74 Personnel

Major Functions & Breakouts	Authorized Staffing	Target Area (SF)	Remarks
Command & Administration	32	2,442	Net SF
Group Commander	1		
Group Superintendent	1		
Deputy Commander	1		
Conference & Meeting			See Chapter 1
Training & Testing			See Chapter 1
Orderly Room/Administration	8		
Weapons Standards Supervisor	1		
Weapons Standards Personnel	3		
Quality Assurance Superintendent	1		
Quality Assurance Mx	10		
Quality Assurance Inspections	6		
Aircraft Maintenance Squadron Section	12	936	Net SF
Commander	1		
First Sergeant	1		
Aircraft Maintenance Superintendent	1		
Aircraft Maintenance	4		
AC Maint Unit A	5		
Maintenance Squadron	8	736	Net SF
Commander	1		
First Sergeant	1		
Maintenance Superintendent	1		
Maintenance Officer	1		
Maintenance Supervision	4		
Maintenance Operations Flight	25	1,732	Net SF
Commander	1		
Superintendent	1		
Maintenance Analysis	3		
Maint Ops Center Manager	1		
Maintenance Operations Center	6		
Planning, Scheduling & Documentation Manager	1		
Planning, Scheduling, & Documentation	4		
T.O. Library & Distribution Center			
Programs and Resources	2		
Maintenance Trng	3		
Support	0	220	Net SF
Break Room			
PPE Training Bag Storage			
Subtotal		6,066	Net SF
25% Overhead		1,517	
Subtotal		7,583	
Functional Standard		7,600	Gross SF

11.6.4 Weapons Systems Maintenance Management (F-35 w/ Contractors), 84 Personnel

Table 11-17: CATCODE 610-129, Weapons Sys Maint (F-35 w/ Contractors), 84 Personnel

Major Functions & Breakouts	Authorized Staffing	Target Area (SF)	Remarks
Command & Administration	32	2,442	Net SF
Group Commander	1		
Group Superintendent	1		
Deputy Commander	1		
Conference & Meeting			See Chapter 1
Training & Testing			See Chapter 1
Orderly Room/Administration	8		
Weapons Standards Supervisor	1		
Weapons Standards Personnel	3		
Quality Assurance Superintendent	1		
Quality Assurance Mx	10		
Quality Assurance Inspections	6		
Contractor Support	10	696	Net SF
Supervisor	1		
Orderly Room/Administration	1		
Maintenance Personnel	8		
Aircraft Maintenance Squadron Section	12	936	Net SF
Commander	1		
First Sergeant	1		
Aircraft Maintenance Superintendent	1		
Aircraft Maintenance	4		
AC Maint Unit A	5		
Maintenance Squadron	8	736	Net SF
Commander	1		
First Sergeant	1		
Maintenance Superintendent	1		
Maintenance Officer	1		
Maintenance Supervision	4		
Maintenance Operations Flight	25	1,732	Net SF
Commander	1		
Superintendent	1		
Maintenance Analysis	3		
Maint Ops Center Manager	1		
Maintenance Operations Center	6		
Planning, Scheduling & Documentation Manager	1		
Planning, Scheduling, & Documentation	4		
T.O. Library & Distribution Center			
Programs and Resources	2		
Maintenance Trng	3		
Support	0	220	Net SF
Break Room			
PPE Training Bag Storage			
Subtotal		6,762	Net SF
25% Overhead		1,691	
Subtotal		8,453	
Functional Standard		8,500	Gross SF

11.6.5 Weapons Systems Maintenance, Airlift Aircraft, 56 Personnel

Table 11-18: CATCODE 610-129, Weapons Sys Maint (Airlift), 56 Personnel

Major Functions & Breakouts	Authorized Staffing	Target Area (SF)	Remarks
Command & Administration	15	2,058	Net SF
Group Commander	1		
Deputy Commander	1		
Executive Officer	1		
Training & Testing			See Chapter 1
Conference & Meeting			See Chapter 1
Orderly Room / Administration	2		
Quality Assurance Manager	1		
Quality Assurance Supervisor	1		
Quality Assurance	8		
Aircraft Maintenance Squadron Section	11	928	Net SF
Commander	1		
Orderly Room / Administration	3		
First Sergeant	1		
Maintenance Officer	1		
Maintenance Manager	1		
Maintenance Supervisor	2		
Maintenance Personnel	2		
Maintenance Squadron	8	680	Net SF
Commander	1		
Orderly Room / Administration	3		
First Sergeant	1		
Maintenance Officer	1		
Maintenance NCOIC	1		
Maintenance Supervisor	1		
Maintenance Operations Flight	22	1,732	Net SF
Commander	1		
Orderly Room / Admin	1		
Superintendent	1		
Maintenance Analysis	3		
Maintenance Operations Center Manager	1		
Maintenance Operations Center	5		
Planning, Scheduling, & Documentation Manager	1		
Planning, Scheduling, & Documentation	5		
T.O. Library & Distribution Center			
Training Manager	1		
Training Personnel	2		
Plans & Resources	1		
Support	0	184	Net SF
Break Room			
PPE Training Bag Storage			
Subtotal		5,582	Net SF
25% Overhead		1,396	
Subtotal		6,978	
Functional Standard		7,000	Gross SF

11.6.6 Weapons Systems Maintenance Management, Tanker Aircraft, 54 Personnel

Table 11-19: CATCODE 610-129, Weapons Sys Maint (Tanker), 54 Personnel

Major Functions & Breakouts	Authorized Staffing	Target Area (SF)	Remarks
Maintenance Group	15	2,170	Net SF
Group Commander	1		
Deputy Commander	1		
Executive Officer	1		
Training & Testing			See Chapter 1
Conference & Meeting			See Chapter 1
Orderly Room / Administration	2		
Quality Assurance Manager	1		
Quality Assurance Supervisor	1		
Quality Assurance	8		
Maintenance Squadron	11	856	Net SF
Commander	1		
Orderly Room / Administration	3		
First Sergeant	1		
Maintenance Officer	1		
Aircraft Maintenance Superintendent	1		
Systems Superintendent	1		
Aircraft Systems	1		
Knowledge Operations Manager	2		
Aircraft Maintenance Squadron	8	736	Net SF
Commander	1		
Orderly Room / Administration	1		
First Sergeant	1		
Superintendent	1		
Maintenance Officer	2		
Knowledge Operations Manager	2		
Maintenance Operations Flight	20	1,556	Net SF
Commander	1		
Orderly Room / Admin	1		
Superintendent	1		
Maintenance Analysis	2		
Maintenance Management	1		
Maintenance Operations Production	5		
T.O. Library & Distribution Center			
Education & Training	2		
Aerospace Maintenance	6		
Aerospace Propulsion	1		
Support	0	186	Net SF
Break Room			
PPE Training Bag Storage			
Subtotal		5,504	Net SF
25% Overhead		1,376	
Subtotal		6,880	
Functional Standard		6,900	Gross SF

11.6.7 Weapons Systems Maintenance Management (MQ-9), 48 Personnel

Table 11-20: CATCODE 610-129, Weapons Sys Maint (MQ-9), 48 Personnel

Major Functions & Breakouts	Authorized Staffing	Target Area (SF)	Remarks
Command & Administration	20	1,814	Net SF
Group Commander	1		
Deputy Commander	1		
Executive Officer	1		
Training & Testing			See Chapter 1
Conference & Meeting			See Chapter 1
Orderly Room / Administration	1		
Quality Assurance Manager	1		
Quality Assurance Supervisor	1		
Quality Assurance	10		
Weapons Standards Manager	1		
Weapons Standards Supervisor	1		
Weapons Standards Personnel	2		
Maintenance Squadron	7	672	Net SF
Commander	1		
Orderly Room / Administration	2		
First Sergeant	1		
Maintenance Officer	1		
Maintenance Manager	1		
Maintenance Superintendent	1		
Aircraft Maintenance Squadron Section	8	736	Net SF
Commander	1		
Orderly Room / Administration	2		
First Sergeant	1		
Maintenance Officer	1		
Maintenance Manager	1		
Maintenance Supervisor	1		
Maintenance Personnel	1		
Maintenance Operations Flight	13	1,044	Net SF
Commander	1		
Superintendent	1		
Maintenance Analysis	2		
Maintenance Operations Center	3		
Planning, Scheduling & Documentation Manager	1		
Planning, Scheduling, & Documentation	2		
T.O. Library & Distribution Center			
Training Manager	1		
Training Personnel	1		
Plans & Resources	1		
Support	0	172	Net SF
Break Room			
PPE Training Bag Storage			
Subtotal		4,438	Net SF
25% Overhead		1,110	
Subtotal		5,548	
Functional Standard		5,500	Gross SF

11.6.1 Weapons Systems Maintenance Management (RPA MCE), 55 Personnel

Table 11-21: CATCODE 610-129, Weapons Sys Maint (RPA MCE), 55 Personnel

Major Functions & Breakouts	Authorized Staffing	Target Area (SF)	Remarks
Command & Administration	20	1,814	Net SF
Group Commander	1		
Deputy Commander	1		
Executive Officer	1		
Training & Testing			See Chapter 1
Conference & Meeting			See Chapter 1
Orderly Room / Administration	1		
Quality Assurance Manager	1		
Quality Assurance Supervisor	1		
Quality Assurance	10		
Weapons Standards Manager	1		
Weapons Standards Supervisor	1		
Weapons Standards Personnel	2		
Maintenance Squadron	11	872	Net SF
Commander	1		
First Sergeant	1		
Maintenance Officer	1		
Maintenance Superintendent	1		
RP Aircraft Maint	3		
Aircraft Maintenance	4		
Aircraft Maintenance Squadron Section	8	680	Net SF
Commander	1		
Orderly Room / Administration	2		
First Sergeant	1		
Maintenance Officer	1		
Maintenance Manager	1		
Maintenance Supervisor	1		
Maintenance Personnel	1		
Maintenance Operations Flight	16	1,236	Net SF
Commander	1		
Superintendent	1		
Maintenance Analysis	3		
Maintenance Operations Center	4		
Planning, Scheduling & Documentation Manager	1		
Planning, Scheduling, & Documentation	2		
T.O. Library & Distribution Center			
Training Manager	1		
Training Personnel	1		
Plans & Resources	2		
Support	0	182	Net SF
Break Room			
PPE Training Bag Storage			
Subtotal		4,784	Net SF
25% Overhead		1,196	
Subtotal		5,980	
Functional Standard		6,000	Gross SF

3
4

11.7 CATCODE 610-287, Specified Headquarters

11.7.1 Each State is authorized space for ANG personnel assigned to the Joint Forces Headquarters (JFHQ). The preferred location of this space is to be collocated with the State JFHQ. However, if space is provided at an ANG base, it cannot be duplicated at JFHQ.

11.7.2 To receive NGB facility sustainment funding, this space must be located on federal property under ANG control via a permit / lease and license.

11.7.3 The Functional Standard is based on the category of each State specified according to military authorizations (MA) within that state or territory.

11.7.3.1 Category A (0 to 2,200 MA): Arkansas, Colorado, Connecticut, Delaware, District of Columbia, Florida, Guam, Idaho, Indiana, Iowa, Kentucky, Louisiana, Maine, Maryland, Montana, Nebraska, Nevada, New Hampshire, New Mexico, North Carolina, North Dakota, Puerto Rico, Rhode Island, South Carolina, South Dakota, Utah, Vermont, Virginia, West Virginia, and Wyoming.

11.7.3.2 Category B (2,201 to 4,000 MA): Alabama, Alaska, Arizona, Georgia, Hawaii, Illinois, Kansas, Massachusetts, Michigan, Minnesota, Mississippi, Missouri, New Jersey, Oklahoma, Oregon, Pennsylvania, Tennessee, Texas, Washington, and Wisconsin.

11.7.3.3 Category C: (Greater than 4,000 MA): California, New York, and Ohio.

11.7.4 Specified Headquarters, Category A, 20 Personnel

Table 11-22: CATCODE 610-287, Specified HQ, Category A, 20 Personnel

Major Functions & Breakouts	Authorized Staffing	Target Area (SF)	Remarks
Command & Administration	5	1,124	Net SF
Assistant AG	1		
Training & Testing			See Chapter 1
Conference & Meeting			See Chapter 1
Chief of Staff	1		
Executive Officer / ESSO	1		
Information Management & Personnel Specialist	1		
Command Chief Master Sergeant	1		
Staff	15	1,224	Net SF
Recruiting & Retention	1		Total varies by State
Judge Advocate	1		
State Air Surgeon	1		
Public Affairs	1		
Director of Operations	1		
Plans Officer	1		
Homeland Security Officer	1		
Operations Resource Manager	1		
Director of Communications	1		
Director of Support	1		
Director of Personnel	1		
Personnel Officer	1		
Personnel / Information Management	3		

Support	0	0	Net SF
Break Area			Use JFHQ facility break area
Subtotal		2,348	Net SF
10% Overhead		235	
Subtotal		2,583	
Functional Standard		2,600	Gross SF

11.7.5 Specified Headquarters, Category B, 22 Personnel

Table 11-23: CATCODE 610-287, Specified HQ, Category B, 22 Personnel

Major Functions & Breakouts	Authorized Staffing	Target Area (SF)	Remarks
Command & Administration	5	1,124	Net SF
Assistant AG	1		
Training & Testing			See Chapter 1
Conference & Meeting			See Chapter 1
Chief of Staff	1		
Executive Officer / ESSO	1		
Information Management & Personnel Specialist	1		
Command Chief Master Sergeant	1		
Staff	17	1,480	Net SF
Recruiting & Retention	1		Total varies by State
Judge Advocate	1		
State Air Surgeon	1		
Public Affairs	1		
Director of Operations	1		
Plans Officer	1		
Homeland Security Officer	1		
Operations Resource Manager	1		
Director of Communications	1		
Director of Support	1		
Director of Personnel	1		
Civil Engineer	1		
Personnel / Information Management	5		
Support	0	0	Net SF
Break Area			Use JFHQ facility break area
Subtotal		2,604	Net SF
10% Overhead		260	
Subtotal		2,864	
Functional Standard		2,900	Gross SF

11.7.6 Specified Headquarters, Category C, 25 Personnel

Table 11-24: CATCODE 610-287, Specified HQ, Category C, 25 Personnel

Major Functions & Breakouts	Authorized Staffing	Target Area (SF)	Remarks
Command & Administration	5	1,124	Net SF
Assistant AG	1		
Training & Testing			See Chapter 1
Conference & Meeting			See Chapter 1
Chief of Staff	1		
Executive Officer / ESSO	1		
Information Management & Personnel Specialist	1		
Command Chief Master Sergeant	1		
Staff	20	1,672	Net SF
Recruiting & Retention	1		Total varies by State
Judge Advocate	1		
State Air Surgeon	1		
Public Affairs	1		
Director of Operations	1		
Plans Officer	1		
Homeland Security Officer	1		
Operations Resource Manager	1		
Director of Communications	1		
Director of Support	1		
Director of Personnel	1		
Personnel Officer	2		
Personnel / Information Management	6		
Logistics Planner	1		
Support	0	0	Net SF
Break Area			Use JFHQ facility break area
Subtotal		2,796	Net SF
10% Overhead		280	
Subtotal		3,076	
Functional Standard		3,100	Gross SF

1 11.7.7 Specified Headquarters, Guam and Virgin Islands, 10 Personnel

2 **Table 11-25: CATCODE 610-287, Specified HQ, Guam and Virgin Islands, 10 Personnel**

Major Functions & Breakouts	Authorized Staffing	Target Area (SF)	Remarks
Command & Administration	5	972	Net SF
Assistant AG	1		
Training & Testing			See Chapter 1
Conference & Meeting			See Chapter 1
Chief of Staff	1		
Information Management	1		
Administration	2		
Staff	5	488	Net SF
Human Resource Advisor	1		
Judge Advocate	1		
Public Affairs	1		
Plans Officer	1		
Homeland Security Officer	1		
Support	0	0	Net SF
Break Area			Use JFHQ facility break area
Subtotal		1,460	Net SF
10% Overhead		146	
Subtotal		1,606	
Functional Standard		1,600	Gross SF

3

11.8 CATCODE 610-811, Administrative Office, Non Air Force

- 11.8.1 This CATCODE identifies those facilities or spaces used for non-Air Force administrative space authorized under a real estate instrument on an ANG installation. Typical organizations include but are not limited to STARBASE Program, Employee Union (one per installation), Civil Air Patrol (CAP), other military branches, DoD and Federal agencies. A permit or license and host tenant support agreement is required in accordance with AFI 32-9003, *Granting Temporary Use of Air Force Real Property*.
- 11.8.2 For Real Property, any contractor space that is under contract and is spelled out in the contract should be under CATCODE 610-811. Especially if the contractor is required to maintain or pay utilities.
- 11.8.3 These functions, when authorized, will utilize space available and therefore do not have a defined functional space standard.
- 11.8.4 Employee Unions may have negotiated specific space requirements within their contract and the installation must be required to provide the negotiated spaces in accordance with the contract.
- 11.8.5 Each installation hosting a STARBASE Program lists a Functional Standard equal to the currently assigned space as noted in real property records. The NGB policy for those installations hosting the STARBASE Program operating out of temporary trailers is to plan to remove the trailers and move the function into a more permanent facility based on space availability. However, the NGB will not support the construction of a separate facility for the STARBASE Program.

11.9 CATCODE 610-913, Emergency Management (EM)

11.9.1 Provides the planning, management, training, and operations to train and prepare all personnel to protect resources from the effects of attacks and/or disaster situations. Restores primary mission assets, and fulfills the humanitarian disaster relief responsibilities of commanders in situations of nuclear, biological, chemical, and/or conventional attack, major peacetime accidents, or large-scale natural disasters. This function is formerly known as Air Base Operability and Readiness.

11.9.2 When possible, the EM area should be collocated with [CATCODE 219-944, Base Civil Engineer Maintenance Shop](#) and [CATCODE 610-127, Base Civil Engineer Administration](#).

Table 11-26: CATCODE 610-913, Emergency Management – 7 and 13 Personnel

Major Functions & Breakouts	Authorized Staffing		Target Area (SF)		Remarks
Command & Administration	2	3	184	304	Net SF
Flight Commander	1	1			
Flight Chief		1			
NCOIC	1	1			
Operations & Training	5	10	1,120	1,440	Net SF
Emergency Management Technicians	5	10			Work stations
Wing Training Classroom / Break Area					Sized for 20 students with tables
Decontamination Area					
Support	0	0	2,611	2,629	Net SF
PPE Training Bag Storage					
Storage Area					
Subtotal			3,915	4,373	Net SF
10% Overhead			392	437	
Subtotal			4,307	4,810	
Functional Standard	7	13	4,300	4,800	Gross SF

NOTES:

- The CBRN cell is located as a sub-element of the EOC in [CATCODE 141-461, Command Post](#).
- If this function is not collocated with the Base Civil Engineer complex, there is no requirement to move it there unless there is a compelling need to vacate their existing space.
- Air National Guard units that receive the Mobile Emergency Operations Center (MEOC) for [Northern Tier Locations](#) are approved to define the covered storage space as: 1,000 Gross SF covered, enclosed and minimally heated storage space [CATCODE 219-943, Base Civil Engineer Pavement and Grounds](#). All other locations that receive the MEOC define space as: 1,000 Gross SF covered shed [CATCODE 219-947, Base Civil Engineer Storage](#).

Chapter 12: Category Groups 72, 73 – Dining Hall and Quarters, Personnel Support

12.1 General Criteria

Category groups 72 and 73 include essentially basic (i.e., minimal) ANG facilities for the feeding of personnel and their temporary /short-term lodging, and space for security forces.

12.2 CATCODE 722-351, Dining & Training Facility

12.2.1 ANG dining and training facilities are consolidated to serve both officer and enlisted personnel. Space requirements vary according to the authorized military strength of the respective installation. This multi-purpose functional area includes seating / dining area, food services line, kitchen area and a small administrative area, not associated with the Sustainment Services Flight (SSF). The SSF functional standard is addressed in [Table 6-5: CATCODE 171-443, Services Flight - 20 / 30 / 41 / 51 Personnel](#). The seating area is considered a base common area and should be usable for larger group training functions and similar needs.

12.2.2 ANG units collocated with another DoD installation with a Dining and Training Facility will typically utilize the existing facility. Should conditions preclude normal access to the existing facility, a separate functional area may be approved using the CATCODE Adjustments Process (Appendix B).

Table 12-1: CATCODE 722-351, Dining & Training Facility

Military Authorizations	Functional Standard (Gross SF)
501 - 1,000	8,500
1,001 - 1,200	10,300
1,201 - 1,600	13,900
1,601 - 1,800	15,700

12.2.3 Geographically Separated units (GSU) are not authorized a Dining and Training Facility unless they are also authorized a Sustainment Services Flight. Food Services for GSUs are handled through contract feeding and a multi-use eating area. The space authorization for each GSU feeding area is included in the GSU space authorization. GSU which are located on another DoD installation having feeding capability are not authorized a feeding area. GSUs also use the dining area as their unit mobility processing area.

Table 12-2: CATCODE 722-351, GSU and RED HORSE Dining & Training Facility

Military Authorizations	Functional Standard (Gross SF)
1 – 150, 1/4 RED HORSE	2,000
151 – 300, 1/2 RED HORSE	4,000
301+	5,400

1 12.3 **CATCODE 723-392, Sanitary Latrine**

2 This function houses latrine, shower, and field laundry space for ANG Regional Training Site
3 (RTS) locations. The Functional Standard is **1,500 Gross SF**.

4

12.4 CATCODE 725-517, Troop Camp (Quarters)

12.4.1 This category is used for combat readiness training centers (CRTCs), regional training sites (RTSs), and other formal training school sites where economically feasible. These facilities include sleeping rooms, lounges or day rooms, study areas, vending areas, laundries, and bathrooms, depending on classification and need.

12.4.2 This CATCODE calculation is based on 8 buildings.

12.4.3 Rapid Runway Repair (RRR) sites are not authorized Troop Camp (Quarters).

Table 12-3: CATCODE 725-517, Troop Camp Quarters

Major Functions & Breakouts	Authorized Staffing	Target Area (SF)	Remarks
Officer	115		150 SF per person
Enlisted (E-7 through E-9)	115		150 SF per person
Enlisted (E-1 through E-6)	520		120 SF per person
Laundry Room			5 SF per person
Meeting Room / Day Room / Study Area / Others			10 SF per person
Vending Area			25 SF per building
Services / Supply Storage			450 SF per building
Subtotal		111,950	Net SF
25% Overhead		27,988	
Subtotal		139,938	
Functional Standard		139,900	Gross SF

NOTE:

- This functional standard applies to CRTC, RTS, REOTS and Lightning Force Academy only; NGB/A4F must approve all other quarters' requests.

1 12.5 **CATCODE 730-832, Visitor Control Center**

2 Facility located near the main entrance to Air Force installations, not typically an ANG facility.
3 Functional Standard for this facility requires NGB/A4F approval based on the number of visitors
4 processed through the main Entry Control Facility. Typical ANG would only have a ([CATCODE](#)
5 [730-837, Traffic Check House](#)) with no Visitor Control Center.

6

12.6 CATCODE 730-835, Security Forces Operations

12.6.1 This facility is the control and operations center for the direction of security, law enforcement, crime prevention, investigation, training, and information, as well as for personnel security and resource protection. The facility also serves as an armory and the site for unit supply. Functional areas include: Law Enforcement Desk, Security Control Center (SCC), and command and administration area.

12.6.2 Security Forces Operations, Stand Alone, 74 Personnel

Table 12-4: CATCODE 730-835, Security Forces Ops, Stand Alone, 74 Personnel

Major Functions & Breakouts	Authorized Staffing	Target Area (SF)	Remarks
Command & Administration	14	1,846	Net SF
Commander	1		
Training & Testing	6		See Chapter 1(+ 200 SF for equipment)
Conference & Meeting			See Chapter 1 (+ 200 SF for equipment)
Executive Officer / NCO	1		
First Sergeant	1		
Orderly Room / Administration	5		
Operations	60	3,636	Net SF
Law Enforcement Desk (LED) & Pass / ID	2		Secure space
Installation Chief of Security	1		
Security Forces Manager	1		
Operations Superintendent	1		
Training Manager	3		
Guard Mount			
Installation Defense Force	21		*no associated SF, post personnel
Hoteling Stations			
Quality Control / Stan / Eval	3		
Flight Chiefs	6		
Program Management	12		
Supply / Mobility Management	3		
Base Defense Operations Center (BDOC)	3		
Weapons Vault	4		Sized for UTC & CATM weapons
Weapons Cleaning Area			
Support	0	1,070	Net SF
Break Area			
PPE Training Bag Storage			
Trailers			2 Trailers @250 SF plus related storage
Subtotal		6,552	Net SF
25% Overhead		1,638	
Subtotal		8,190	
Functional Standard	74	8,200	Gross SF

NOTE:

- The Alternate Base Defense Operations Center (BDOC) is authorized 400 Gross SF but this function must be physically located in another facility, and identified with this CATCODE.
- The additional Functional Standard for the Security Forces Operations mission is provided under CATCODE 442-758, Base Supply & Equipment Warehouse – 2,500 SF (Table 9-3)

12.6.3 Security Forces Operations, Stand Alone, 87 Personnel

Table 12-5: CATCODE 730-835, Security Forces Ops, Stand Alone, 87 Personnel

Major Functions & Breakouts	Authorized Staffing	Target Area (SF)	Remarks
Command & Administration	14	1,846	Net SF
Commander	1		
Training & Testing	6		See Chapter 1(+ 200 SF for equipment)
Conference & Meeting			See Chapter 1 (+ 200 SF for equipment)
Executive Officer / NCO	1		
First Sergeant	1		
Orderly Room / Administration	5		
Operations	73	4,050	Net SF
Law Enforcement Desk (LED) & Pass / ID	2		Secure space
Installation Chief of Security	1		
Security Forces Manager	1		
Operations Superintendent	1		
Training Manager	3		
Guard Mount			
Installation Defense Force	34		*no associated SF, post personnel
Hoteling Stations			
Quality Control / Stan / Eval	3		
Flight Chiefs	6		
Program Management	12		
Supply / Mobility Management	3		
Base Defense Operations Center (BDOC)	3		
Weapons Vault	4		Sized for UTC & CATM weapons
Weapons Cleaning Area			
Support	0	1,130	Net SF
Break Area			
PPE Training Bag Storage			
Trailers			2 Trailers @250 SF plus related storage
Subtotal		7,026	Net SF
25% Overhead		1,757	
Subtotal		8,783	
Functional Standard		8,800	Gross SF

NOTE:

3. The Alternate Base Defense Operations Center (BDOC) is authorized 400 Gross SF but this function must be physically located in another facility, and identified with this CATCODE.
4. The additional Functional Standard for the Security Forces Operations mission is provided under CATCODE 442-758, Base Supply & Equipment Warehouse – 2,500 SF (Table 9-3)

12.6.4 Security Forces Operations, Stand Alone, 118 Personnel

Table 12-6: CATCODE 730-835, Security Forces Ops, Stand Alone, 118 Personnel

Major Functions & Breakouts	Authorized Staffing	Target Area (SF)	Remarks
Command & Administration	14	1,936	Net SF
Commander	1		
Training & Testing	6		See Chapter 1(+ 200 SF for equipment)
Conference & Meeting			See Chapter 1 (+ 200 SF for equipment)
Executive Officer / NCO	1		
First Sergeant	1		
Orderly Room / Administration	5		
Operations	104	4,422	Net SF
Law Enforcement Desk (LED) & Pass / ID	2		Secure space
Installation Chief of Security	1		
Security Forces Manager	1		
Operations Superintendent	1		
Training Manager	3		
Guard Mount			
Installation Defense Force	65		*no associated SF, post personnel
Hoteling Stations			
Quality Control / Stan / Eval	3		
Flight Chiefs	6		
Program Management	12		
Supply / Mobility Management	3		
Base Defense Operations Center (BDOC)	3		
Weapons Vault	4		Sized for UTC & CATM weapons
Weapons Cleaning Area			
Support	0	1,271	Net SF
Break Area			
PPE Training Bag Storage			
Trailers			2 Trailers @250 SF plus related storage
Subtotal		7,575	
25% Overhead		1,894	
Subtotal		9,469	
Functional Standard	118	9,500	

NOTE:

5. The Alternate Base Defense Operations Center (BDOC) is authorized 400 Gross SF but this function must be physically located in another facility, and identified with this CATCODE.
6. The additional Functional Standard for the Security Forces Operations mission is provided under CATCODE 442-758, Base Supply & Equipment Warehouse – 2,500 SF (Table 9-3)

12.6.5 Security Forces Operations, Collocated, 61 Personnel

Table 12-7: CATCODE 730-835, Security Forces Ops, Collocated, 61 Personnel

Major Functions & Breakouts	Authorized Staffing	Target Area (SF)	Remarks
Command & Administration	14	1,846	Net SF
Commander	1		
Training & Testing	6		See Chapter 1(+ 200 SF for equipment)
Conference & Meeting			See Chapter 1 (+ 200 SF for equipment)
Executive Officer / NCO	1		
First Sergeant	1		
Orderly Room / Administration	5		
Operations	47	3,438	Net SF
Law Enforcement Desk (LED) & Pass / ID	2		Secure space
Installation Chief of Security	1		
Security Forces Manager	1		
Operations Superintendent	1		
Training Manager	3		
Guard Mount			
Installation Defense Force	8		
Hoteling Stations			
Quality Control / Stan / Eval	3		
Flight Chiefs	6		
Program Management	12		
Supply / Mobility Management	3		
Base Defense Operations Center (BDOC)	3		
Weapons Vault	4		Sized for UTC & CATM weapons
Weapons Cleaning Area			
Support	0	1,031	
Break Room			
PPE Training Bag Storage			3 SF/Mobility Position (61) - orginally calculated using 88 personnel
Trailers			2 Trailers @250 SF plus related storage
Subtotal		6,315	
25% Overhead		1,579	
Subtotal		7,894	
Functional Standard	61	7,900	

NOTE:

1. The Alternate Base Defense Operations Center (BDOC) is authorized 400 Gross SF but this function must be physically located in another facility, and identified with this CATCODE.
2. The additional Functional Standard for the Security Forces Operations mission is provided under CATCODE 442-758, Base Supply & Equipment Warehouse – 2,000 SF (Table 9-3)

12.6.6 Security Forces Operations, CRTC

Table 12-8: CATCODE 730-835, Security Forces Ops, CRTC

Major Functions & Breakouts	Authorized Staffing	Target Area (SF)	Remarks
Command & Administration	11	1,196	Net SF
Commander	1		
Training & Testing			See Chapter 1
Conference Room			See Chapter 1
First Sergeant	1		
Orderly Room / Administration	9		
Operations	12	1,132	Net SF
Installation Chief of Security	1		
Security Forces Manager	1		
Operations Superintendent	1		
Training Manager	1		
Quality Control / Stan / Eval	1		
Flight Chiefs Area	2		
Program Management Work Area	1		
Supply / Mobility Management	1		
Security Control Center (SCC)	1		
Weapons Vault	1		Sized for Honor Guard, day-to-day weapons
Weapons Cleaning Area	1		
Support	0	100	Net SF
Break Area			
Subtotal		2,428	Net SF
25% Overhead		607	
Subtotal		3,035	
Functional Standard		3,000	Gross SF

12.6.7 Security Forces Operations, Deployed / Visiting Unit, CRTC

Table 12-9: CATCODE 730-835, Security Forces Ops (Deployed / Visiting Unit - CRTC)

Major Functions & Breakouts	Authorized Staffing	Target Area (SF)	Remarks
Command & Administration	4	1,752	Net SF
Commander	1		
First Sergeant	1		
Training & Testing			See Chapter 1
Conference & Meeting			See Chapter 1
Orderly Room / Administration	2		
Information Management Center			
Operations	2	2,710	Net SF
Security Control Center (SCC)	2		

Major Functions & Breakouts	Authorized Staffing	Target Area (SF)	Remarks
Weapons Vault			Sized for deployed weapons / ammunition
Weapons Clean / Repair / Clear Area			
Pallet Build Up			
Utility Vehicle Storage			8 ATV's and trailers plus 1M-Gator
Support	0	264	Net SF
Personnel Equipment Lockers (M / F)			
Subtotal		4,726	Net SF
25% Overhead		1,182	
Subtotal		5,908	
Functional Standard		5,900	Gross SF

1

2

1 **12.7 CATCODE 730-837, Security Entry Control Building**

2 12.7.1 Facility designed for entry point security and is required at alert aircraft areas and at other
3 restricted areas as critical mission requirements dictate.

4 12.7.2 The facility includes the entry control building and the personnel and vehicle entrapment
5 areas connected to the surrounding security fence. The facility must accommodate at least
6 two individuals, controls for the mechanically operated gates, exchange badge racks, and
7 controls for pedestrian turnstiles. The functional standard is 200 Gross SF but additional
8 space may be authorized to meet mission requirements.

9

12.8 CATCODE 730-839, Traffic Gatehouse and Guard Booth

- 12.8.1 Two separate buildings using the same CATCODE thus can capture the Guard Booth on Real Property records when a Guard Booth is used. Would be two separate lines on the 1391 for a Main Gate as 300 SF Gatehouse (Figure 12-1) and 32 SF Guard Booth, (see Figure 12-4) for details. Facility(-ies) for traffic control and is required at entrances to ANG installations, Guard Booth is optional.
- 12.8.2 Provide a Gatehouse for each ECF/ACP. The Gatehouse serves as the central control center for the ECF/ACP by providing shelter for security personnel and controls for the Active Vehicle Barriers (AVBs), traffic control devices, access controls, lighting, and surveillance equipment. For the ANG the visitor center is combined with the Gatehouse to reduce the ECF/ACP footprint and maximize manpower; however, there must be a ballistic rated separation between the guards and the portion of the building accessible to the public (see Figure 12-1 for the Bank Teller window used since 2004 at the Main Gate Gatehouse). Passes are issued and visitor logs completed at the Gatehouse. The Main Gate Gatehouse is located on a median with optional ballistic shielded ID Check, See Figure 12-1 and Figure 12-7
- 12.8.3 Provide a Guard Booth (Real Property) or ECF mobile ballistic shield (not Real Property) for each entry lane within the ID check area. Provide ballistic protection equivalent to Underwriters Laboratories (UL) 752 Level III for Gatehouse, Guard Booth (when used), and mobile ballistic shield (when used) as a minimum per UFC 4-022-01. The Guard Booth (when used) will have a protected, emergency activation control for the AVBs per UFC 4-022-01.
- 12.8.4 The Main Gate will include a Gatehouse with overhead protection at one inbound vehicle lane (canopies can cover all inbound lanes if a secondary gate is available that can handle oversized vehicles, see Figure 12-9 and Figure 12-10), over watch vehicle parking position, traffic islands separating directions of travel, active vehicle barriers, security gate, security fencing, lighting and uncovered or covered commercial vehicle inspection ([CATCODE 145-921, Overhead Protection](#)). Layout will match the ANG typical ECF (used since 2003), which is refinements tailored to the ANG thus the controlling layout, (see Figure 12-7, Figure 12-8, and Figure 12-11), which is based on the AF Low Volume ECF and SDDCTEA Exhibit 1.20: Low Volume ECF with POV Processing (see Figure 12-5). The ECF must meet the 9 seconds from ID Check to Final Denial Barrier (see Section 11.8.9 and Figure 12-6) and does not follow any SDDCTEA less safe reductions in time. The ECF will meet the WB-67 sweep path to include a WB-67 turn around after the gatehouse and/or WB-67 turn around after commercial vehicle inspection with entry and exit through the approach zone (see Figure 12-11).
- 12.8.5 Per AFI 32-1062 the ECF will use a Portable generator connection with no UPS.
- 12.8.6 For an ANG GSU use a Low Volume Automated Vehicle Gate and ABA Compliant Pedestrian Turnstile(s) per UFC 4-022-01: Appendix B - Navy Gate Automation as a starting point. Coordinate with NGB/A4FR and NGB/A4IC for site-specific details to meet the operational needs.

12.8.7 The corresponding CATCODEs for the other elements of an ECF:

- 12.8.7.1 [CATCODE 145-921, Overhead Protection](#)
- 12.8.7.2 [CATCODE 730-839, Traffic Gatehouse and Guard Booth](#)
- 12.8.7.3 [CATCODE 730-832, Visitor Control Center](#)
- 12.8.7.4 [CATCODE 872-245, Boundary Fence](#)
- 12.8.7.5 [CATCODE 872-247, Security Fence / Vehicle Barriers](#)
- 12.8.7.6 [CATCODE 872-249, Gate, Boundary Fence and Wall](#)
- 12.8.7.7 [CATCODE 872-300, Mechanical Security Barricades](#)

Table 12-10: CATCODE 730-839, Traffic Check House (Gatehouse)

Facility Basis	Functional Standard (Gross SF)
Main Gate (ANG Wing)	300
Secondary Entrance (ANG Wing)	100 (See Note 1)
GSU	35 max (See Note 2)

NOTES:

1. If Secondary Gate is full-time then can apply for 160 SF if needed to become Architectural Barrier Act (ABA) compliant.
2. Used as part of Low Volume Automated Vehicle Gate scheme (see section 12.8.6) and the Gatehouse is only used during busy times above the automated cars per hour pace.

Figure 12-1: CATCODE 730-839, Main Gate Gatehouse detailed layout, in use since 2004

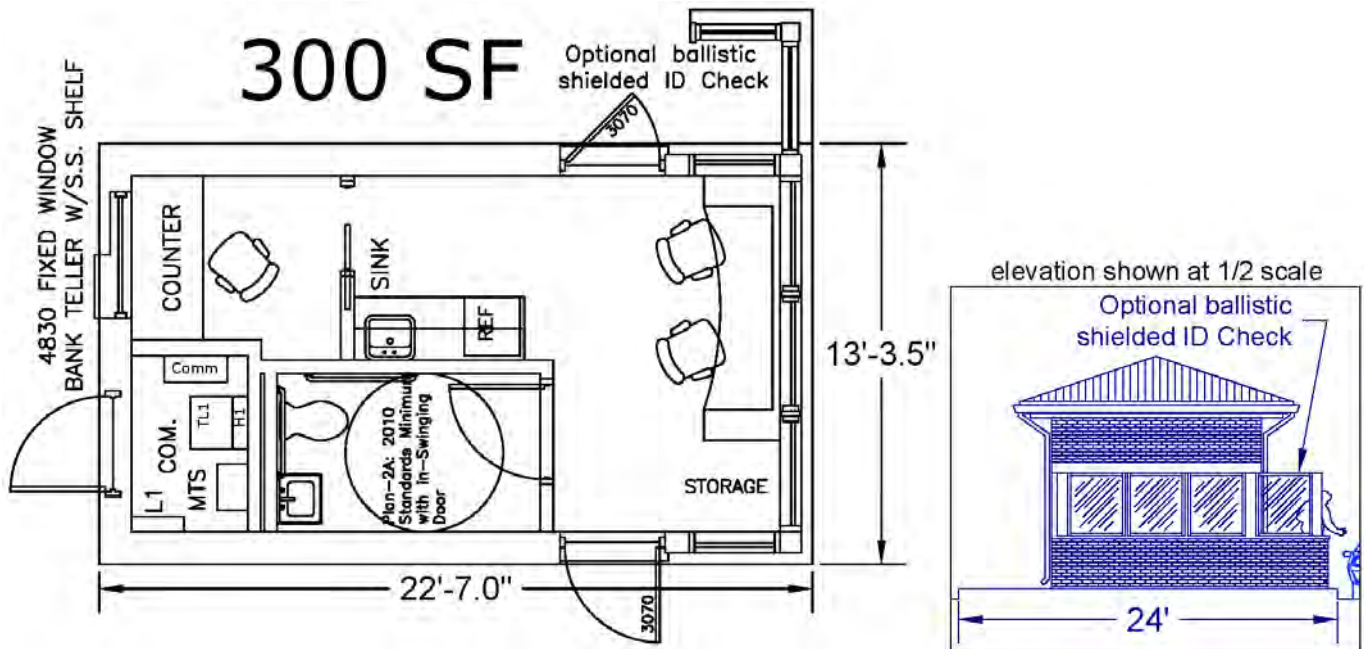

1 12.8.8 Guard Booth: size 4x8 for 32 SF with double sliding doors placed 6” from the road for
 2 oncoming traffic to provide protection while checking IDs. AF Does use the Guard Booth
 3 6” from the roadway curb edge.

4 **Figure 12-2: Guard Booth size based on Army Corps standard and Andrews Guard Booth**

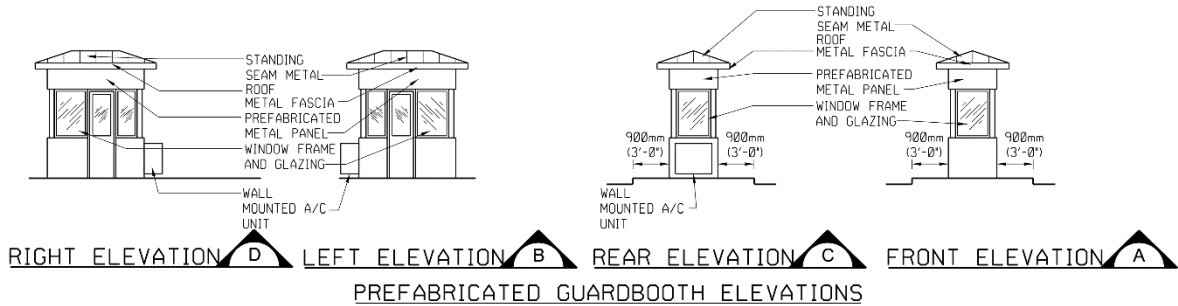

5
 6

Figure 12-3: Air Force use of ID Check 6” from edge of curb



7
 8

Figure 12-4: CATCODE 730-839, Guard Booth layout and elevation details, when used

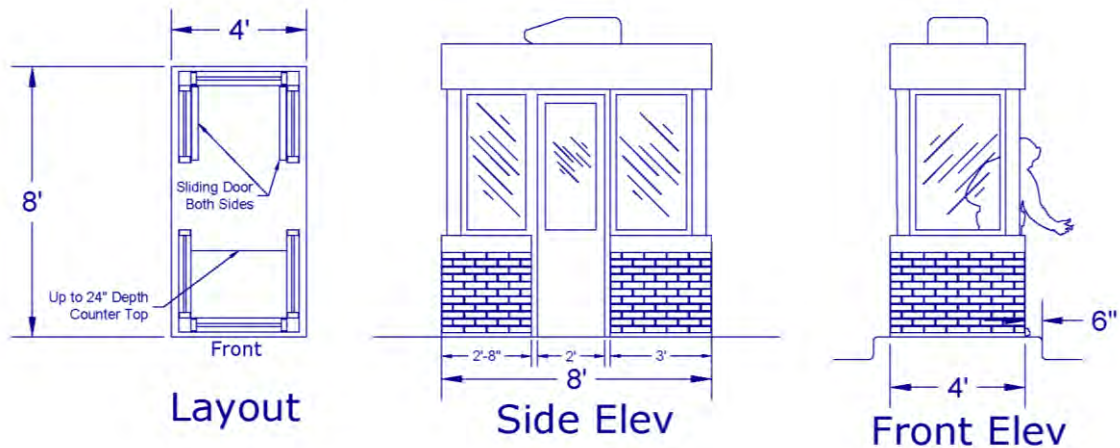

9
 10

Figure 12-5: SDDCTEA Exhibit 1.20: Low Volume ECF with POV Processing and AF Low Volume, for reference

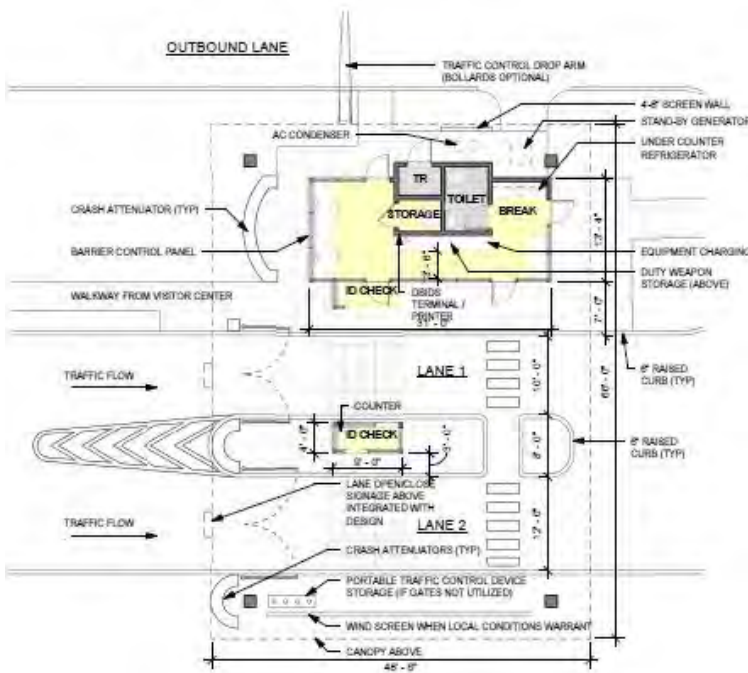
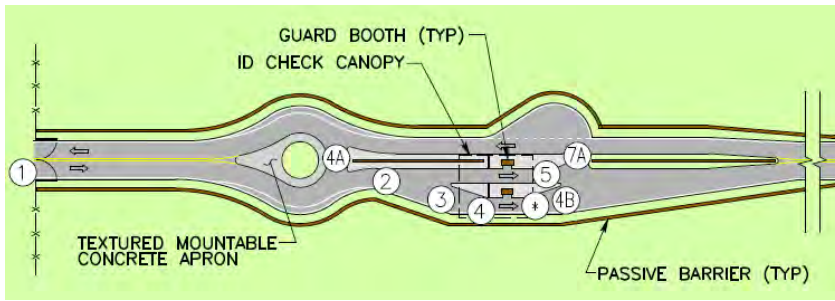

12.8.9 ECF with POV Processing will provide 9 seconds form ID Check to Final Denial Barrier. Check for 9 seconds using the Find_9 html file at <https://intelshare.intelink.gov/sites/ngba4/SitePages/Find%209.aspx> Can print to pdf after use to show proof of 9 seconds. (See Figure 11-6 below)

Figure 12-6: NGB/A4 SharePoint Find 9 Tool intro and launch page from above link

1

Figure 12-7: ANG ECF Template Detailed View separated vehicle inspection

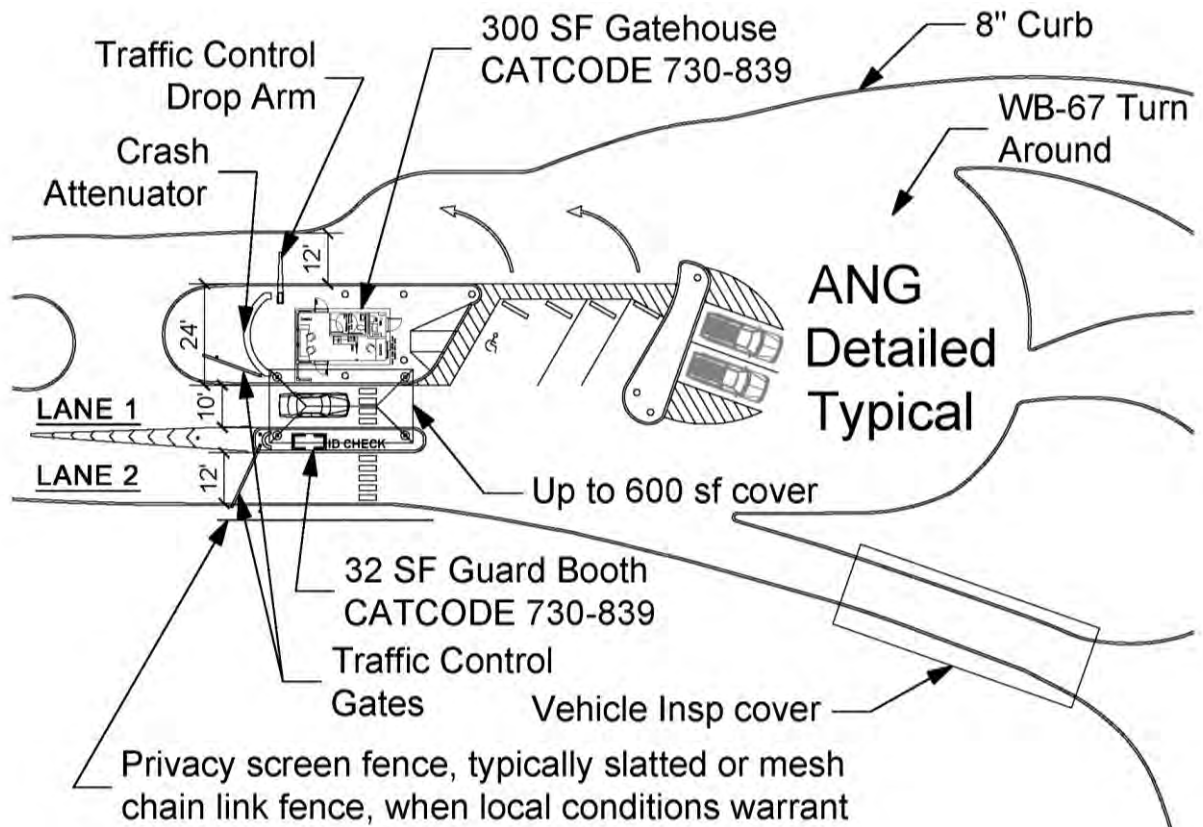

2

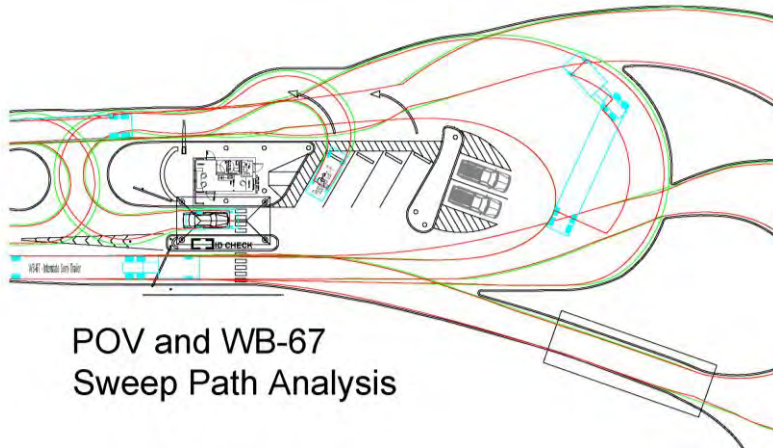

3

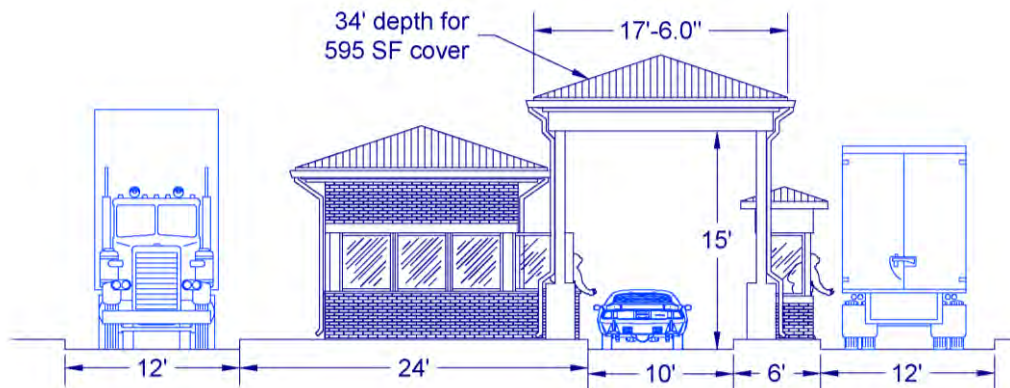

4

1 **Figure 12-8: ANG ECF Template Detailed View collocated commercial vehicle inspection**

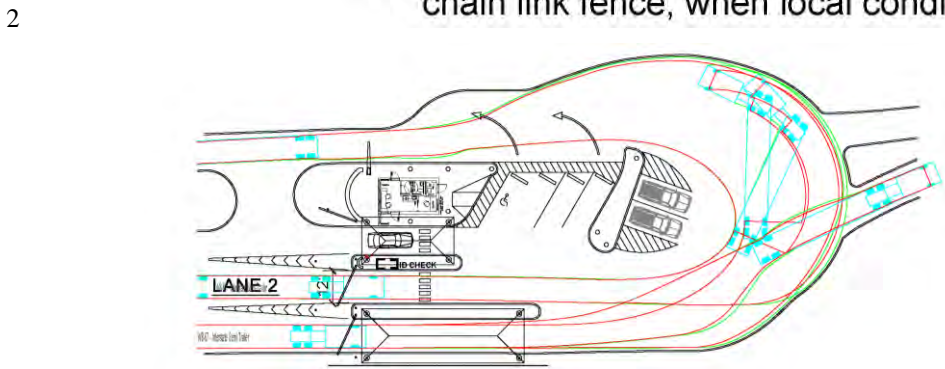
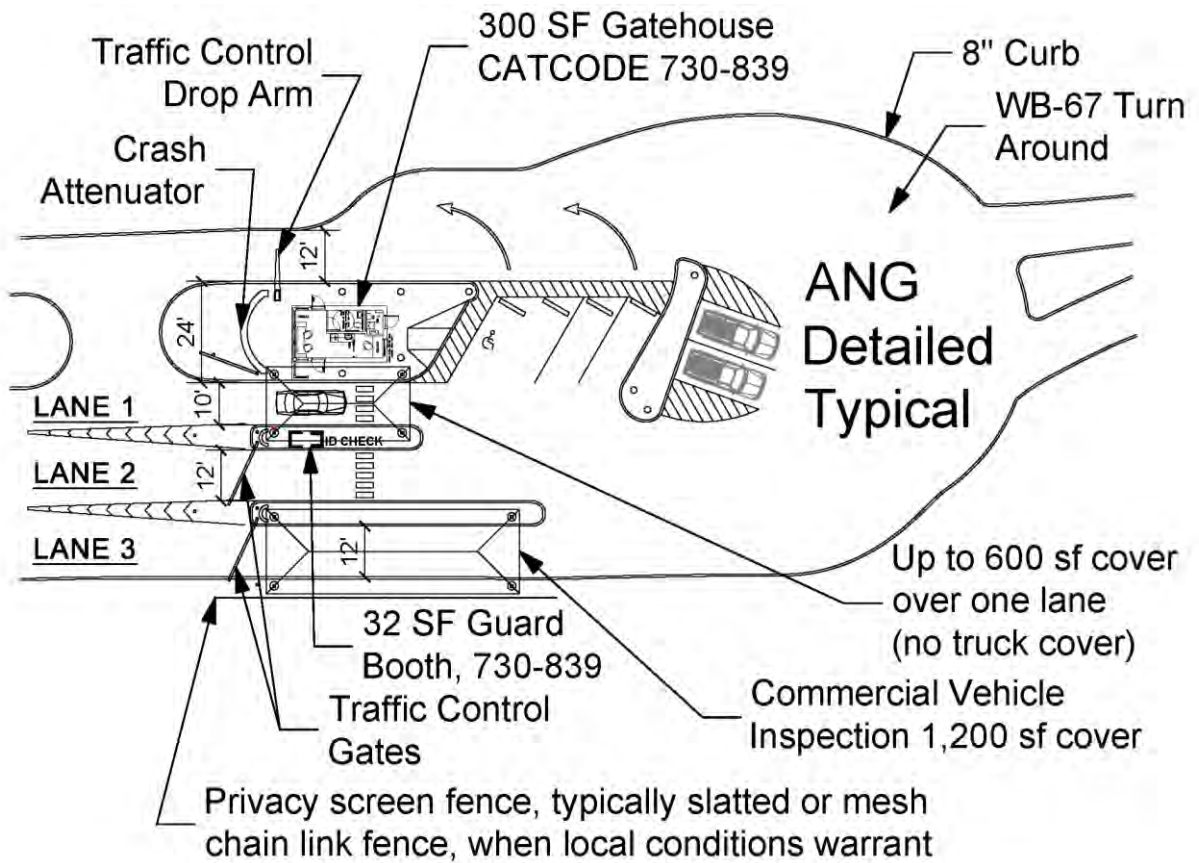

2 **Sweep Path Analysis**

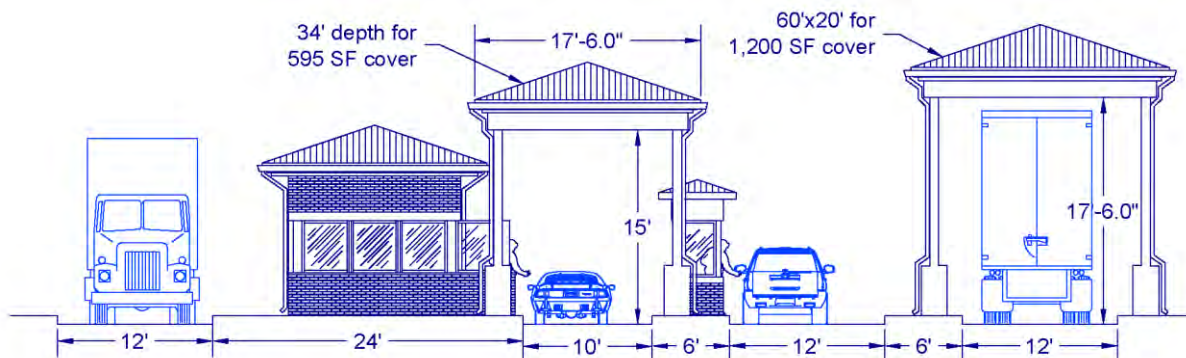

3

1
2

Figure 12-9: ANG ECF Template two lanes in with separated commercial inspection, use only if a secondary gate is available and can handle oversized vehicles.

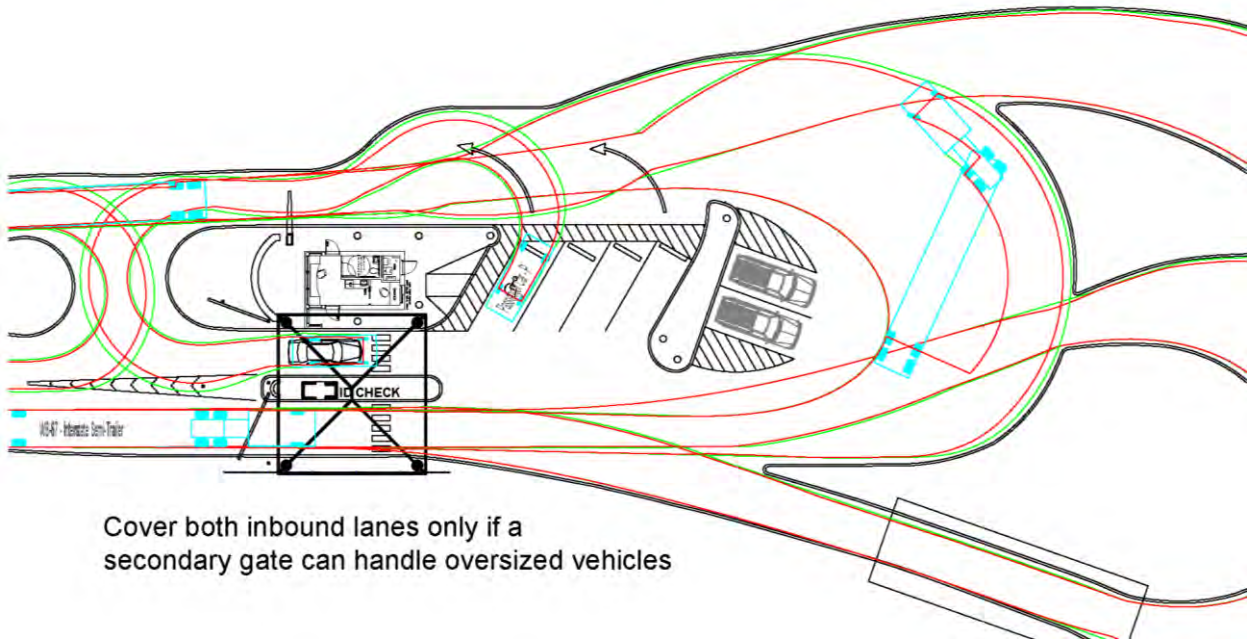

3

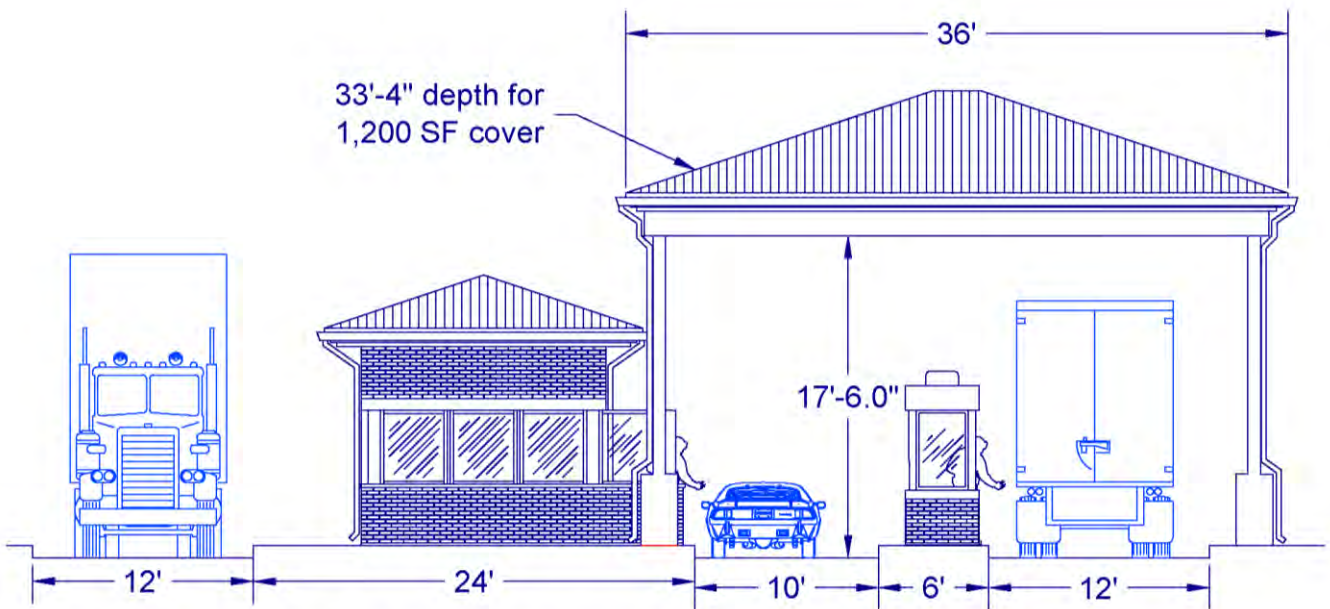

4
5
6
7
8

Cover all inbound lanes only if a secondary gate can handle oversized vehicles

1
2
3
4
5
6
7
8
9
10

Figure 12-10: ANG ECF Template colocated commercial vehicle inspection, use only if a secondary gate is available and can handle oversized vehicles

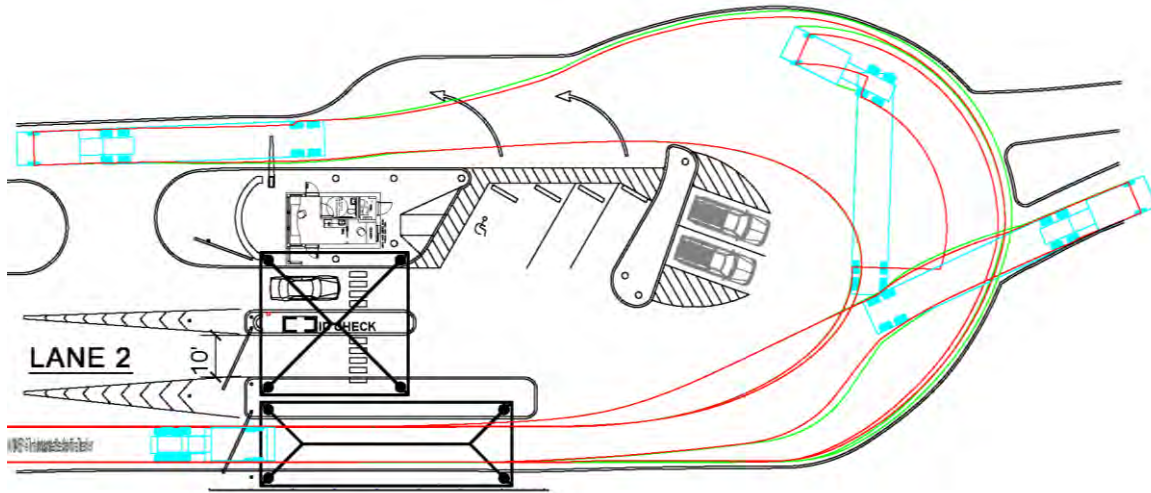

Cover all inbound lanes only if a secondary gate can handle oversized vehicles

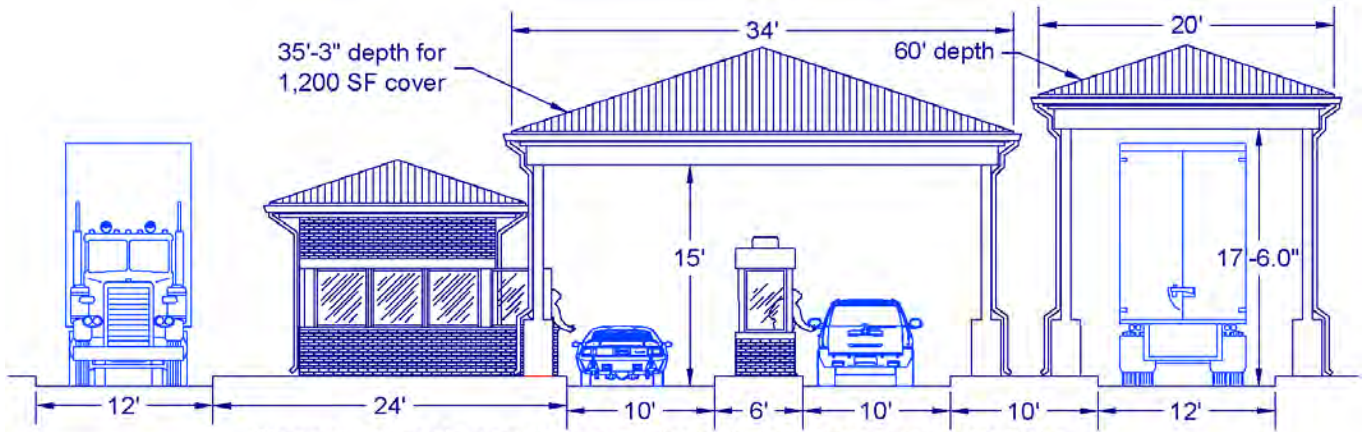

Cover all inbound lanes only if a secondary gate can handle oversized vehicles

1 **Figure 12-11: ANG ECF Template complete layout, use of curves to meet the 9 seconds**

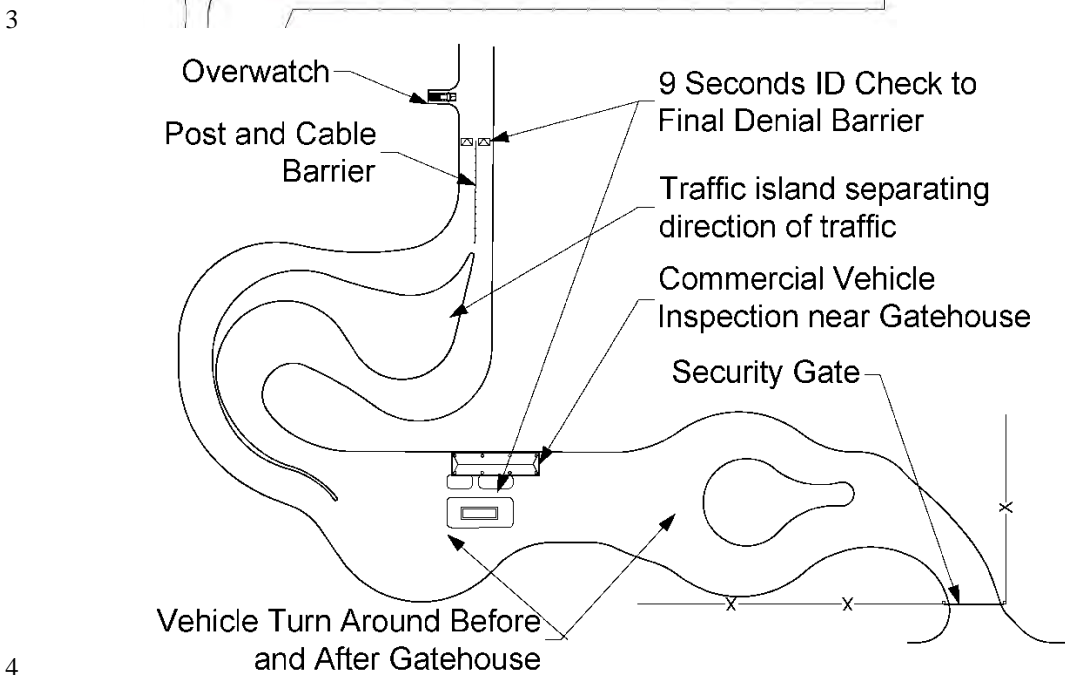
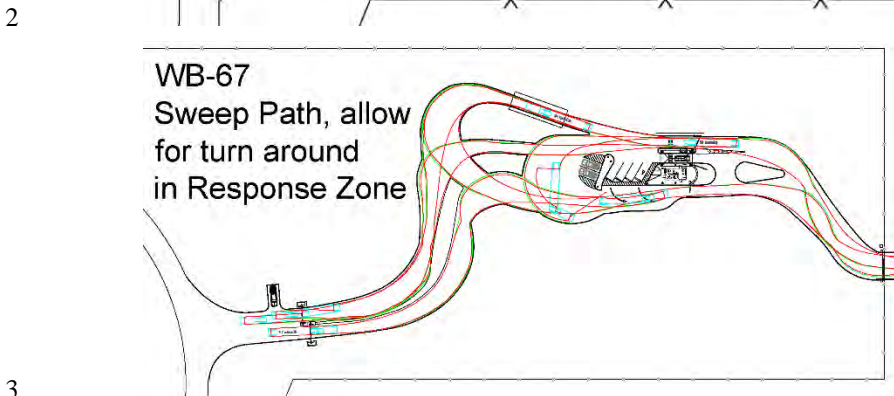
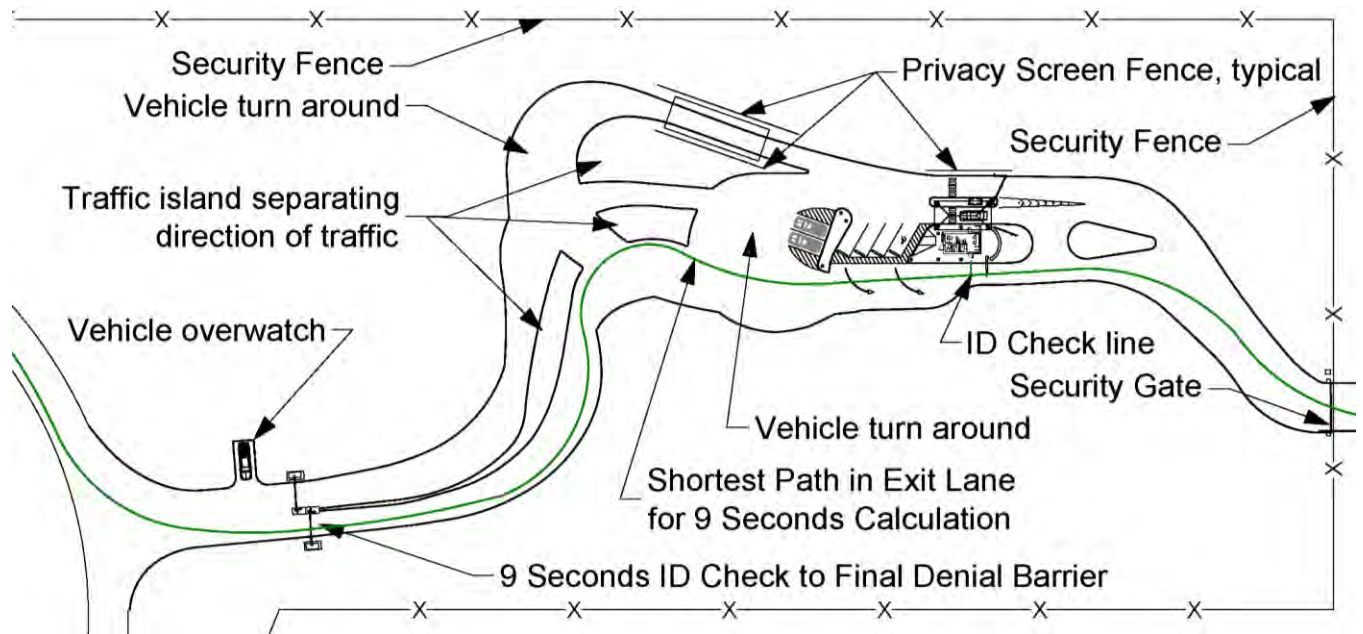

4

Chapter 13: Category Groups 74, 75 – Morale, Welfare, and Recreation Facilities

13.1 General Criteria

13.1.1 The requirement for Morale, Welfare, and Recreation (MWR) facilities varies according to the using service. ANG installations are authorized limited MWR activities and facilities since the ANG does not have Non-Appropriated Funds (NAF) instrumentalities to fund the activities or facilities.

13.1.2 When MWR facilities are authorized, ANG shall not use troop labor for maintenance, repair, minor construction, or major construction.

13.1.3 The following MWR Activities are authorized using Appropriated Funds:

13.1.3.1 Fitness Center, [CATCODE 740-674, Physical Fitness](#)

13.1.3.2 Running Track, [CATCODE 750-177, Athletic Field, Track](#)

13.1.3.3 All other MWR facilities must be approved by NGB/A4F.

13.2 CATCODE 740-155, Credit Union

13.2.1 This CATCODE identifies those spaces that provide credit union or similar banking services on an ANG installation.

13.2.2 A license and host tenant support agreement is required in accordance with *AFI 32-9003, Granting Temporary Use of Air Force Real Property*.

13.2.3 These functions, when authorized, will utilize space available and therefore do not have a defined functional space standard.

13.3 CATCODE 740-389, Exchange Service Outlet

13.3.1 This CATCODE identifies those spaces that provide special sales or similar service outlets considered branches of the main Base Exchange in an ANG installation.

13.3.2 A host tenant support agreement is required in accordance with *AFI 32-9003, Granting Temporary Use of Air Force Real Property*.

13.3.3 These functions, when authorized, will utilize space available and therefore do not have a defined functional space standard.

13.4 CATCODE 740-674, Physical Fitness

13.4.1 Fitness areas facilitate the readiness, fitness, and morale of ANG members in support of standards set forth in AFMAN 36-2905, *Air Force Physical Fitness Program*. This section outlines Functional Standards to provide physical fitness areas to allow ANG members to participate in a year-round physical conditioning program, emphasizing total fitness in support of the Air Force and ANG mission. Also include multi-functional spaces under this CATCODE 740-674 for Combatives as outlined in AFI 36-2620, *Air Force Combatives Program*, when assigned and coordinated to conduct home station Combatives training to include the Security Forces Combatives and Defender Performance Optimization Room per AFI 36-2646, A3.2.2. Do not use CATCODE 172-424 for Combatives because we do not earn Sustainment in 172-424.

Table 13-1: CATCODE 740-674, Physical Fitness

Function	Functional Standard (Gross SF) per Military Authorizations			
	Aircraft Ranges	GSU (or < 500)	501 - 1,000	1,001 - 1,800 & CRTC
Fitness Area	300	700	2,400	3,000

NOTES:

1. A physical fitness center is not typically authorized for ANG units on another DoD installation that allows access to the installation physical fitness facility.
2. The physical fitness center is intended to be collocated with another base function. Ten percent (10%) Overhead included in Gross SF above.

13.5 CATCODE 750-177, Athletic Field, Track

13.5.1 Outdoor running track used to support military personnel physical fitness requirements. Prior to programming an exclusive use running track, the following two options and one condition should be considered:

13.5.1.1 Use of existing base pavements with appropriate markings.

13.5.1.2 Use of available local community running tracks or marked trails.

13.5.1.3 Economic analysis along with written plan that an exclusive use running track fits mission need specifically addressing amount of people that to test at one time and scheduling process.

13.5.2 The construction of an exclusive use running track must be approved by NGB/A4F:

13.5.2.1 Things to consider, an exclusive use track may not meet mission needs due to amount of people that can test at one time compared to single lap or single turn-around marked off route.

13.5.2.2 An exclusive use running track, when possible, should meet UFC 4-750-02 specification for lane width of 42”, slope, and drainage (coordinate with State or Local Environmental for Stormwater Management & Impact).

13.5.2.3 Per UFC 4-750-02 Lane Lines shall be 2 inches and lane width shall be 42 inches outside lane line edge to outside lane line edge. Do not suggest use of a curb thus inner most lane line outside edge is the layout and measuring edge.

13.5.2.4 Line of running is 12 inches or .3 meter inside the measuring edge, use Line of Running to measure running distance.

13.5.2.5 For width, use a 3 lane running track without a curb thus 10 feet 8 inches inside the lanes, 8 inches of paving inside the first lane and 12 inches outside the last lane for an overall 12 feet 4 inches of asphalt paving, about 1,846 SY for a 1/4 mile track.

Table 13-2: CATCODE 750-177, Exclusive Use Running Track Options

Type of Track	Source for layout	Track outside edge of inner most lane line		Overall Track outside edge of pavement	
		Straight	Radius	Length	Width
1/4 mile track	U.S. Army Fitness Trng Handbook	279'-9.75"	120'	542'-6"	262'-8"
1/4 mile track	Typical 440 yard track, 110 yard straight	330'	104'-1"	560'-9"	230'-9"
400 meter track*	UFC 4-750-02	328'-1"	103'-5"	557'-7"	229'-6"
400 meter track*	Intl. Assoc. of Athletics Federation (IAAF)	276'-10"	119'-9"	539'	262'-2"

*Airmen who run the 1.5-mile event on a 400-meter track must run six laps plus an additional 46 feet.

1

Figure 13-1: CATCODE 750-177, Running Track Layout

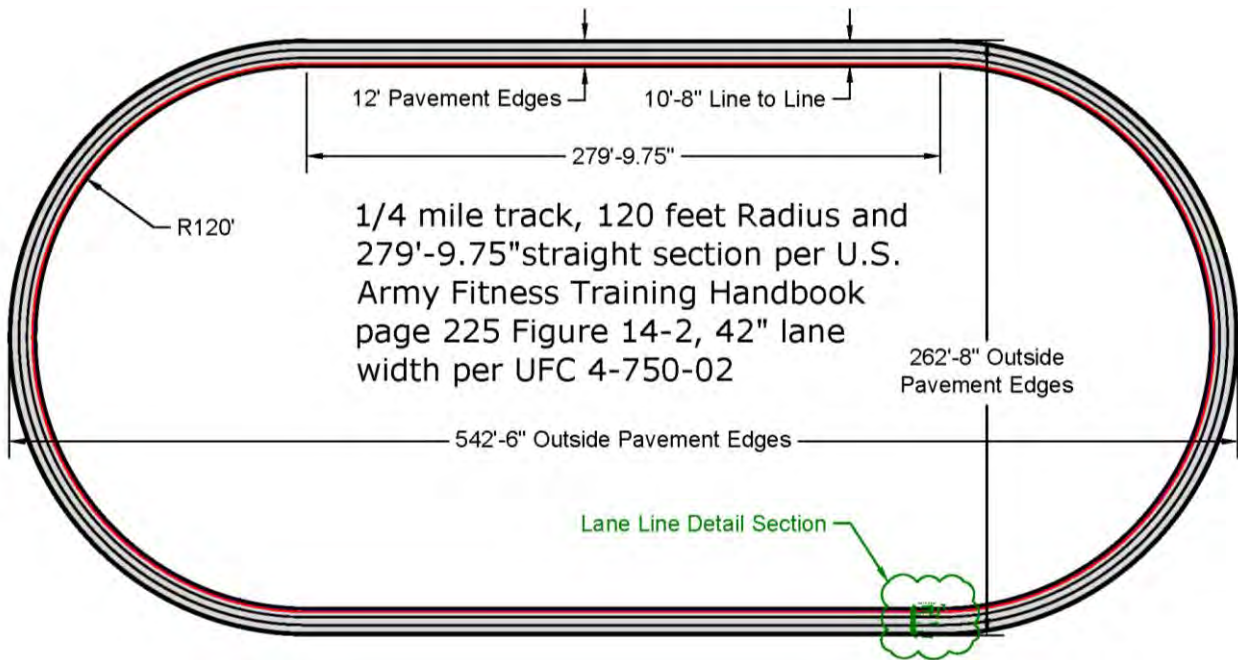

2

3

Figure 13-2: CATCODE 750-177, Running Track Lane Line Details

Lane Line Details

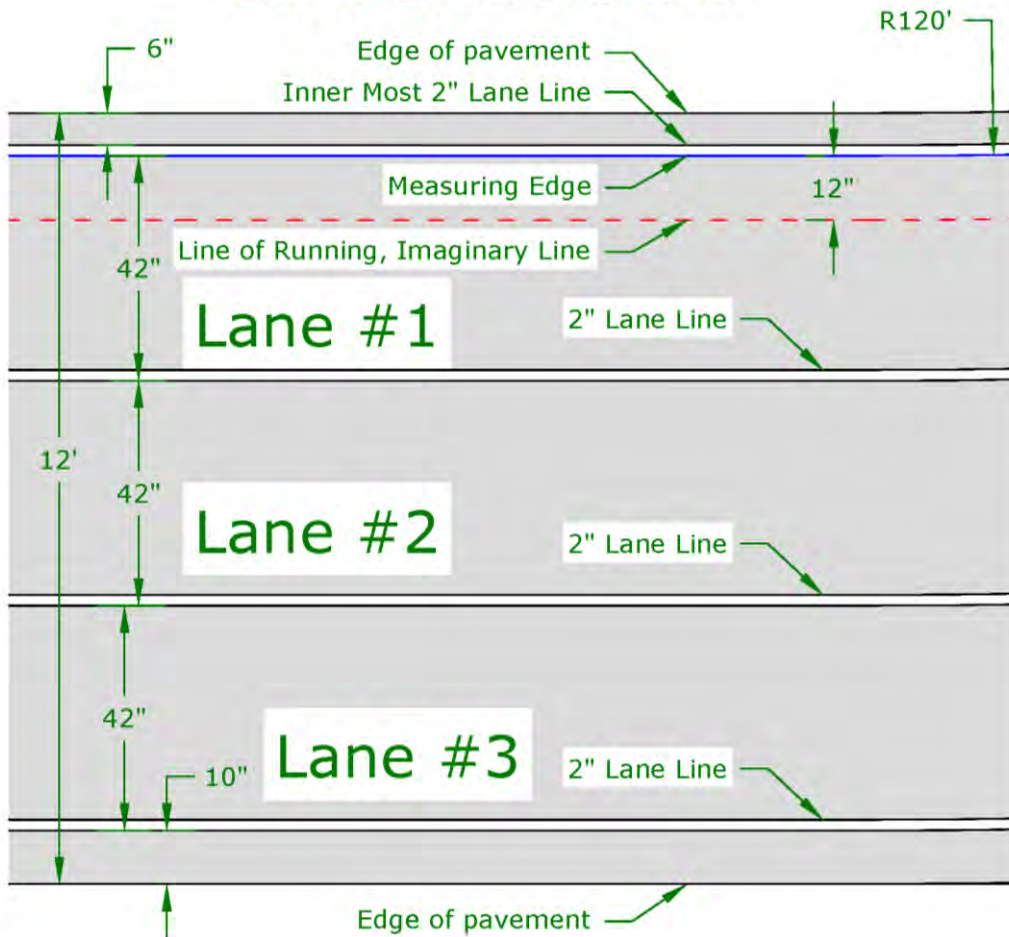

4

13.6 CATCODE 750-371, Recreational Pavilion

- 13.6.1 A covered, open-sided, multi-purpose function outfitted to support installation exercises and training events, recreation activities and physical fitness programs. Can have multiple Pavilions that total is up to or less than the assigned Functional Standard for the installation.
- 13.6.2 Concrete slab square footage will match the covered square footage as a 400 SF pavilion will have a 4 00 SF concrete slab.
- 13.6.3 All portions are considered full scope because the intended purpose is open sided and this CATCODE gets a reduced O&M plus AFMAN 32-1084 defines size of pavilion suggesting full scope. Do not build double the size and count as half scope.

Table 13-3: CATCODE 750-371, Recreational Pavilion

Function	Functional Standard (Gross SF) per Military Authorizations		
	GSU (or < 500)	501 - 1,000	1,001 - 1,800 & CRTC
Recreational Pavilion	400	600	800

Chapter 14: Category Group 85, 87, 89 – Roads, Streets, and Utilities

14.1 General Criteria

Roads and streets are authorized in support of ANG functions. Address individual installation requirements with NGB/A4FD.

14.2 CATCODE 852-261, Vehicle Parking Operations

- 14.2.1 This facility provides parking space for organizational vehicles at two types of locations: the main pool, normally adjacent to [Vehicle Operations Administration \(CATCODE 610-121\)](#); and authorized sub-pools adjacent to other operating locations whose functions requires 24 hour access to a substantial number of their assigned vehicles. Typical organizations requiring sub-pools are Civil Engineering, Fire, aircraft maintenance, and security forces. Pools and sub-pools require a paved or stabilized surface; the central pool requires floodlighting, security fence at least 6 ft. high, and one or more controlled paved entrances.
- 14.2.2 To determine the amount of vehicle parking required at the main pool and at the individual sub-pools, follow the following process:
- 14.2.2.1 Using the base Vehicle Authorization List, identify all vehicles for which the Base Transportation Office is responsible.
 - 14.2.2.2 Subtract all vehicles that are regularly parked at open locations other than the main pool and sub-pools described above.
 - 14.2.2.3 Subtract those vehicles parked in buildings and sheds such as [Base Civil Engineer Pavements and Grounds Facility \(CATCODE 219-943\)](#), [Vehicle Operations Heated Parking \(CATCODE 214-426\)](#), and [Vehicle Operations Parking Shed \(CATCODE 214-428\)](#).
 - 14.2.2.4 Among the remaining vehicles, identify those that will be assigned to the main pool and each sub-pool, then refer to Table 13-1 to determine the required amount of vehicle parking space.
 - 14.2.2.5 Vehicle parking facility to be fenced and secured, to be separated from base populace and other POV assets.

Table 14-1: CATCODE 852-261, Vehicle Parking Operations

Balance of Authorized V.E.s See Note 1	Functional Standard (SY)
50 – 100	3,800
101 – 150	5,825
151 – 250	9,700
251 – 350	13,600
351 – 450	17,500
451 – 650	25,250
651 – 850	32,500
851 – 1,000	41,500

NOTE 1: Excludes specialty vehicles such as fire trucks, refuelers and BCE equipment.

14.3 **CATCODE 852-262, Non-Organizational Vehicle Parking**

- 14.3.1 DoD policy is to provide off-street parking at military installations, rather than build wider streets to accommodate on-street parking. Where facilities are located near each other, parking areas should be combined and reduced to the extent consistent with normal operations.
- 14.3.2 Determine the Functional Standard for non-organizational vehicle parking by multiplying 75% of an installation's combined Unit Manning Document (UMD) total strength times 35 SY. GSU manning cannot be added to the installation's UMD total strength for the purposes of this calculation UNLESS the GSU is collocated on the same installation with the Wing. This Functional Standard provides the parking spaces and circulation space for the installation.
- 14.3.3 Visitor, ADA compliant and Government Operated Vehicle (GOV) parking spaces are not included in the UMD calculation. Visitor parking will not exceed 1% of the installation's 75% total, while ADA compliant parking will comply with *Americans with Disabilities Act (ADA) Accessibility Guidelines, Section 4 (Accessible Elements and Spaces: Scope and Technical Requirements)*.

14.4 **CATCODE 852-263, Vehicle Parking (Unsurfaced)**

This is an unsurfaced area for parking vehicles. The area should be graded gravel for longevity. In most cases, these areas can also be dual used for equipment set up and training purposes.

14.5 CATCODE 852-269, Refueler Vehicle Parking

- 14.5.1 Refueler Vehicle Parking is a paved area usually located close to (and considered part of) the jet fuel storage and operations complex. Under circumstances described in [CATCODE 121-111, Petroleum Operations Building](#), a **150 Gross SF** vehicle checkpoint and operator maintenance facility may be located in the complex.
- 14.5.2 **600 SY** of paved area is allowed for each authorized refueling unit or hydrant-servicing vehicle (hose truck). **400 SY** of paved area is allowed for each RPA fueling cart.

Figure 14-1: CATCODE 852-269, example parking lot for refueling trucks



14.6 **CATCODE 852-273, Aircraft Support Equipment Storage Yard**

This function is required for the standby storage of powered and non-powered ASE that has been repaired and is awaiting dispatch. This area is paved and if justified, can be fenced and lighted. The functional standard is **900 SY**. See [CATCODE 218-712](#), for space authorization.

14.7 **CATCODE 872-245, Boundary Fence**

As a general rule, the perimeter of ANG installations will be delineated by some type of fencing. In exceptional cases the entire installation may have a uniform degree of security importance, however, as a practical matter, all areas, materials, and facilities within an installation are not of equal security priority. Economical and realistic satisfaction of an installation commander's legal and moral responsibilities for the protection of property under his / her command can usually be satisfied by the use of Type A2 fence. However, the type of fence required at the boundaries of livestock grazing land that adjoin airfield operational areas requires special study and determination.

14.8 **CATCODE 872-247, Security Fence / Vehicle Barriers**

As differentiated from a boundary fence, a security fence is required to enhance security or protective efforts established in response to Restricted or Controlled Areas. This CATCODE also includes passive vehicle barrier structures like steel cables and bollards used with the fence. Restricted or Controlled Areas may also have Active Vehicle Barriers (AVBs) (see [CATCODE 872-300 Mechanical Security Barricades](#)) and security overwatch facilities where applicable.

14.9 **CATCODE 872-248, Fence, Interior**

Fences that promote personnel or traffic safety, operating efficiency, or environmental protection. This structure is not for security or boundary demarcation.

14.10 **CATCODE 872-249, Gate, Boundary Fence and Wall**

The frame, gate, or other apparatus that allows or restricts vehicle and animal entrance on access roads and pedestrian access through the perimeter fences ([CATCODE 872-245, Boundary Fence](#)) or walls of an installation. Unit of measure is Linear Feet (LF). Same as roads report existing total LF. Used for the manned gates at the gatehouse and any unmanned boundary security fence gate that have to stay locked to the public.

14.11 **CATCODE 872-300, Mechanical Security Barricades**

Mechanically operated active vehicle barrier/barricade consisting of bollards, rising road plates/wedges, Crash Beam Barrier System, sliding gate Crash Gate System, steel cables Ground Retractable Automobile Barrier designed to control vehicle or other traffic. EA (each) is defined as a single barricade. All barriers costs include barrier installation, remote controls, safety loops, traffic arm, and traffic lights. CCTV, cameras, and alarms are considered equipment and are not included.

14.12 CATCODE 890-181, Utility Line Ducts

Underground concrete encased ducts used for installation of electrical, telephone cable, fiber optical communications lines, hot water lines, etc. See [CATCODE 132-133, Equipment Pad](#) for associated equipment pad(s) if required.

Chapter 15: Supplementary Tables for Authorized Functional Areas by Category Code

15.1 Supplementary Tables

Consolidated lists of authorizations are listed in the following supplementary tables for specific aircraft types, Aircraft Ranges, Combat Readiness Training Centers (CRTCs), RED HORSE units, Regional Training Sites (RTSs), Regional Equipment Operators Training Sites (REOTSS), and Geographically Separated Units (GSUs).

15.1.1 The total authorized areas for the F-15 weapon system is listed in Table 14.1.

Table 15-1: F-15 Fighter Unit.

Cat Code	Nomenclature	ANGH 32-1084 Authorization	Remarks (F-15)
113-321	Apron (Square Yards)	Compute	Based on PAA
116-661	Arm/Disarm Pad (Each)	Compute	Based on PAA
116-665	Power Check Pad (Each)	1	With suppressor
116-667	Compass Calibration Pad	1	
116-672	Wash Rack (Each)		By Exception, See CATCODE Included in 211-111 or 211-179
116-922	Arresting System (Each)	2	
121-111	POL Operations	1,500	Based on UTA personnel
124-134	Operating Storage - Diesel (Gallons)	5,000	
124-135	POL Storage (Gallons/Barrels)	210,000/5,000	Up to 24 PAA
124-137	Operating Storage - MOGAS (Gallons)	5,000	
125-977	Pumping Station (SF)	1,500	
126-925	Truck Fill Stand (OL)	2	
126-926	Truck Unloading Stand (OL)	2	
130-142	Fire Crash/Rescue Station	Compute	See CATCODE
131-111	Communications	10,200	
141-165	Explosive Ordnance Disposal (EOD)	Compute	If authorized
141-383	Audio/Visual Services Center	660	
141-453	Base Operations	2,000	
141-461	Command Post	2,800	
141-753	Squadron Operations	17,500	
141-786	Deployment Processing	7,900	
171-212	Flight Simulator	Compute	If authorized
171-443	Reserve Forces General Training	Compute	Honor Guard, services, weather, or ALCE flight if authorized
171-445	Reserve Forces Operations & Training	16,800	
171-450	Medical Training	10,300	4000 SF if joint use

Cat Code	Nomenclature	ANGH 32-1084 Authorization	Remarks (F-15)
171-475	Range, Small Arms, Indoor		Coordinate for approval. See CATCODE, and see 179-475, either/or not both
171-476	Combat Arms Training & Maintenance (CATM)	1,050	If authorized with range, see CATCODE
171-875	Weapons Loading Crew Training	7,900	Increase to 8,300 SF if stand-alone
179-475	Small Arms Range (Firing Points)		Coordinate for approval. See CATCODE, and see 171-475, either/or not both
211-111	Aircraft Maintenance Hangar	28,000	For new construction will use Medium or Large Hangar
211-152	General Purpose (GP) Maintenance Shops	16,300	
211-153	Non-Destructive Inspection	2,800	
211-154	Aircraft Maintenance Unit (AMU) Shop	9,000	
211-157	Aircraft Engine Maintenance Shop	Compute	See CATCODE
211-159	Corrosion Control	11,100	
211-179	Fuel Systems Maintenance Dock	10,000	
	External Wing Tank Storage Area (SY)	Compute	Use CATCODE 132-133, Equipment Pad for Tank Storage
214-425	Vehicle Maintenance Shop	Compute	Based on vehicle equivalents
214-428	Vehicle Operations Parking Shed	Compute	Based on number of vehicles
214-467	Refueler Vehicle Maintenance	1,500	
215-552	Weapons Release	14,400	
216-642	Conventional Munitions Maintenance Shop	16,000	Includes 2,900 SF of Admin
217-712	Avionics Shop	9,200	
217-713	ECM Pod Shop/Storage	Compute	See CATCODE
218-712	Aircraft Support Equipment (ASE)	Compute	Based on pieces of equipment
219-943	BCE Pavements & Grounds	Compute	Based on unit tasking
219-944	Base Civil Engineer Maintenance Shop	5,400	
219-947	Civil Engineer Storage Building	4,000	(Prime BEEF)
422-258	Above Ground Magazine Storage	6,140	
422-264	Igloo Storage	3,600	See CATCODE
442-257	Base Hazardous Storage	1,800	
442-258	LOX/LIN Storage	210	
442-628	Base Supplies and Equipment Shed	2,500	
442-758	Base Supply Warehouse	21,200	

Cat Code	Nomenclature	ANGH 32-1084 Authorization	Remarks (F-15)
452-252	Supply Open Storage (SY)	600	
452-255	BCE Open Storage (SY)	3,600	Not to exceed 3,600, build to need not to maximum
610-121	Vehicle Operations Administration	1,900	Based on authorized personnel
610-122	Base Supply Administration	5,000	
610-127	BCE Administration	4,800	(Prime BEEF)
610-129	Weapon System Maintenance Management	7,300	
610-287	Specified Headquarters	Compute	Based on category - if authorized
610-913	Air Base Operability	Compute	Based on authorized personnel
722-351	Dining Hall	Compute	Based on authorized personnel
730-835	Security Forces Operations	Compute	Based on authorized personnel
730-839	Traffic Gatehouse and Guard Booth	300	Main gatehouse
730-839	Access Control Facility (Guard Booth)	32	Main gate guard booth when used
740-674	Physical Fitness Center	Compute	Based on authorized personnel
852-261	Vehicle Operations Parking (SY)	Compute	As required by GOV'S
851-262	Non-Organizational Parking (SY)	Compute	75% UTA (35 SY/vehicle)
852-269	Refueler Vehicle Parking (SY)	Compute	600 SY/authorized vehicle

15.1.2 The total authorized areas for the F-15EX weapon system is listed in Table 14.1.

Table 15-2: F-15EX Fighter Unit.

Cat Code	Nomenclature	ANGH 32-1084 Authorization	Remarks (F-15EX)
113-321	Apron (Square Yards)	Compute	Based on PAA
116-661	Arm/Disarm Pad (Each)	Compute	Based on PAA
116-665	Power Check Pad (Each)	1	With suppressor
116-667	Compass Calibration Pad	1	
116-672	Wash Rack (Each)		By Exception, See CATCODE Included in 211-111 or 211-179
116-922	Arresting System (Each)	2	
121-111	POL Operations	1,500	Based on UTA personnel
124-134	Operating Storage - Diesel (Gallons)	5,000	
124-135	POL Storage (Gallons/Barrels)	210,000/5,000	Up to 24 PAA
124-137	Operating Storage - MOGAS (Gallons)	5,000	
125-977	Pumping Station (SF)	1,500	
126-925	Truck Fill Stand (OL)	2	
126-926	Truck Unloading Stand (OL)	2	
130-142	Fire Crash/Rescue Station	Compute	See CATCODE
131-111	Communications	10,200	
140-422	Secure Space Mission Planning Cell, Flying Wings	2,000	See 141-753 for the F-15EX. Moved intel from Sqd Ops to 140-422
141-165	Explosive Ordnance Disposal (EOD)	Compute	If authorized
141-383	Audio/Visual Services Center	660	
141-453	Base Operations	2,000	
141-461	Command Post	2,800	
141-753	Squadron Operations	17,100	
141-786	Deployment Processing	7,900	
171-212	Flight Simulator	2,500	If authorized
171-443	Reserve Forces General Training	Compute	Honor Guard, services, weather, or ALCE flight if authorized
171-445	Reserve Forces Operations & Training	16,800	
171-450	Medical Training	10,300	4000 SF if joint use
171-475	Range, Small Arms, Indoor		Coordinate for approval. See CATCODE, and see 179-475, either/or not both
171-476	Combat Arms Training & Maintenance (CATM)	1,050	If authorized with range, see CATCODE
171-875	Weapons Loading Crew Training	7,900	Increase to 8,300 SF if stand-alone
179-475	Small Arms Range (Firing Points)		Coordinate for approval. See CATCODE, and see 171-475, either/or not both
211-111	Aircraft Maintenance Hangar	28,000	For new construction will use Medium or Large Hangar

Cat Code	Nomenclature	ANGH 32-1084 Authorization	Remarks (F-15EX)
211-152	General Purpose (GP) Maintenance Shops	16,300	
211-153	Non-Destructive Inspection	2,800	
211-154	Aircraft Maintenance Unit (AMU) Shop	9,000	
211-157	Aircraft Engine Maintenance Shop	Compute	See CATCODE
211-159	Corrosion Control		Under review
211-179	Fuel Systems Maintenance Dock	10,400	Add in space for CFT Tester, see CATCODE
	External Wing Tank Storage Area	Compute	Use CATCODE 132-133, Equipment Pad for Tank Storage, see 211-179 for details
214-425	Vehicle Maintenance Shop	Compute	Based on vehicle equivalents
214-428	Vehicle Operations Parking Shed	Compute	Based on number of vehicles
214-467	Refueler Vehicle Maintenance	1,500	
215-552	Weapons Release	14,400	
216-642	Conventional Munitions Maintenance Shop	16,700	Includes 3,600 SF of Admin
217-712	Avionics Shop	9,200	
217-713	ECM Pod Shop/Storage	Compute	See CATCODE
218-712	Aircraft Support Equipment (ASE)	Compute	Based on pieces of equipment
219-943	BCE Pavements & Grounds	Compute	Based on unit tasking
219-944	Base Civil Engineer Maintenance Shop	5,400	
219-947	Civil Engineer Storage Building	4,000	(Prime BEEF)
422-258	Above Ground Magazine Storage	6,140	
422-264	Igloo Storage	4,000	
442-257	Base Hazardous Storage	1,800	
442-258	LOX/LIN Storage	210	
442-628	Base Supplies and Equipment Shed	2,500	
442-758	Base Supply Warehouse	21,200	
452-252	Supply Open Storage (SY)	600	
452-255	BCE Open Storage (SY)	3,600	Not to exceed 3,600, build to need not to maximum
610-121	Vehicle Operations Administration	1,900	Based on authorized personnel
610-122	Base Supply Administration	5,000	
610-127	BCE Administration	4,800	(Prime BEEF)
610-129	Weapon System Maintenance Management	7,300	
610-287	Specified Headquarters	Compute	Based on category - if authorized

Cat Code	Nomenclature	ANGH 32-1084 Authorization	Remarks (F-15EX)
610-913	Air Base Operability	Compute	Based on authorized personnel
722-351	Dining Hall	Compute	Based on authorized personnel
730-835	Security Forces Operations	Compute	Based on authorized personnel
730-839	Traffic Gatehouse and Guard Booth	300	Main gatehouse
730-839	Access Control Facility (Guard Booth)	32	Main gate guard booth when used
740-674	Physical Fitness Center	Compute	Based on authorized personnel
852-261	Vehicle Operations Parking (SY)	Compute	As required by GOV'S
851-262	Non-Organizational Parking (SY)	Compute	75% UTA (35 SY/vehicle)
852-269	Refueler Vehicle Parking (SY)	Compute	600 SY/authorized vehicle

15.1.3 The total authorized areas for the F-16 weapon system is listed in Table 14.2.

Table 15-3: F-16 Fighter Unit.

Cat Code	Nomenclature	ANGH 32-1084 Authorization	Remarks (F-16)
113-321	Apron (Square Yards)	Compute	Based on PAA
116-661	Arm/Disarm Pad (Each)	Compute	Based on PAA
116-665	Power Check Pad (Each)	1	With suppressor
116-672	Wash Rack (Each)		By Exception, See CATCODE Included in 211-111 or 211-179
116-922	Arresting System (Each)	2	
121-111	POL Operations	1,500	Based on UTA personnel
124-134	Operating Storage - Diesel (Gallons)	5,000	
124-135	POL Storage (Gallons/Barrels)	105,000/2,500	Up to 24 PAA
124-137	Operating Storage - MOGAS (Gallons)	5,000	
125-977	Pumping Station	1,500	
126-925	Truck Fill Stand (OL)	2	
126-926	Truck Unloading Stand (OL)	2	
130-142	Fire Crash/Rescue Station	Compute	See CATCODE
131-111	Communications	10,200	
141-165	Explosive Ordnance Disposal	Compute	If authorized
141-383	Audio/Visual Services Center	660	
141-453	Base Operations	2,000	
141-461	Command Post	2,800	
141-753	Squadron Operations	17,500	
141-786	Deployment Processing	7,900	
171-212	Flight Simulator	Compute	If authorized
171-443	Reserve Forces General Training	Compute	Honor Guard, services, weather, or ALCE flight if authorized
171-445	Reserve Forces Operations & Training	16,800	
171-450	Medical Training	10,300	4000 SF if joint use
171-475	Range, Small Arms, Indoor		Coordinate for approval. See CATCODE, and see 179-475, either/or not both.
171-476	Combat Arms Training & Maintenance (CATM)	1,050	If authorized with range, see CATCODE
171-875	Weapons Loading Crew Training	7,900	Increase to 8,300 SF if stand-alone

Cat Code	Nomenclature	ANGH 32-1084 Authorization	Remarks (F-16)
179-475	Small Arms Range (Firing Points)		Coordinate for approval. See CATCODE, and see 171-475, either/or not both
211-111	Aircraft Maintenance Hangar	28,000	For new construction will use Medium or Large Hangar
211-152	General Purpose Maintenance Shops	16,300	
211-153	Non-Destructive Inspection	2,800	
211-154	Aircraft Maintenance Unit (AMU) Shop	9,000	
211-157	Aircraft Engine Maintenance Shop	Compute	See CATCODE
211-159	Corrosion Control	11,100	
211-179	Fuel Systems Maintenance Dock	10,000	
	External Wing Tank Storage Area (SY)	Compute	Use CATCODE 132-133, Equipment Pad for Tank Storage
214-425	Vehicle Maintenance Shop	Compute	Based on vehicle equivalents
214-426	Vehicle Operations Heated Parking	Compute	Based on unit requirements
214-428	Vehicle Operations Parking Shed	Compute	Based on number of vehicles
214-467	Refueler Vehicle Maintenance	1,500	
215-552	Weapons Release	14,400	
216-642	Conventional Munitions Maintenance Shop	16,300	Includes 3,200 SF of Admin
217-712	Avionics Shop	9,200	
217-713	ECM Pod Shop/Storage	Compute	See CATCODE
218-712	Aircraft Support Equipment (ASE)	Compute	Based on pieces of equipment
219-943	BCE Pavements & Grounds	Compute	Based on unit tasking
219-944	Base Civil Engineer Maintenance Shop	5,400	
219-947	Civil Engineer Storage Building	4,000	
422-258	Above Ground Magazine Storage	6,140	
422-264	Igloo Storage	3,600	
442-257	Base Hazardous Storage	Compute	1,800 Base Hazardous Storage 800 SF Hydrazine Stge/Serviceing 200 SF Hydrazine Storage only
442-258	LOX/LIN Storage	210	

Cat Code	Nomenclature	ANGH 32-1084 Authorization	Remarks (F-16)
442-628	Base Supply & Equipment Shed	2,500	
442-758	Base Supply Warehouse	21,200	
452-252	Supply Open Storage (SY)	600	
452-255	BCE Open Storage (SY)	3,600	Not to exceed 3,600, build to need not to maximum
610-121	Vehicle Operations Administration	1,900	
610-122	Base Supply Administration	5,000	
610-127	BCE Administration	4,800	(Prime BEEF)
610-129	Weapon System Maintenance Management	7,300	
610-287	Specified Headquarters	Compute	Based on category - if authorized
610-913	Air Base Operability	Compute	Based on authorized personnel
722-351	Dining Hall	Compute	Based on authorized personnel
730-835	Security Forces Operations	Compute	Based on authorized personnel
730-839	Traffic Gatehouse and Guard Booth	300	Main gatehouse
730-839	Access Control Facility (Guard Booth)	32	Main gate guard booth when used
740-674	Physical Fitness Center	Compute	Based on authorized personnel
852-261	Vehicle Operations Parking (SY)	Compute	As required by GOV's
851-262	Non-Organizational Parking (SY)	Compute	75% UTA (35 SY/vehicle)
852-269	Refueler Vehicle Parking (SY)	Compute	600 SY/authorized vehicle

15.1.4 The total authorized areas for the F-22 weapon system is listed in Table 14.3.

Table 15-4: F-22 Fighter Unit.

Cat Code	Nomenclature	ANGH 32-1084 Authorization	Remarks (F-22)
113-321	Apron (Square Yards)	Compute	Based on PAA
116-661	Arm/Disarm Pad (Each)	Compute	Based on PAA
116-665	Power Check Pad (Each)	1	With suppressor
116-672	Wash Rack (Each)		By Exception, See CATCODE Included in 211-111 or 211-179
116-922	Arresting System (Each)	2	
121-111	POL Operations	1,500	Based on UTA personnel
124-134	Operating Storage - Diesel (Gallons)	5,000	
124-135	POL Storage (Gallons/Barrels)	105,000/2,500	Up to 24 PAA
124-137	Operating Storage - MOGAS (Gallons)	5,000	
125-977	Pumping Station	1,500	
126-925	Truck Fill Stand (OL)	2	
126-926	Truck Unloading Stand (OL)	2	
130-142	Fire Crash/Rescue Station	Compute	See CATCODE
131-111	Communications	10,200	
141-165	Explosive Ordnance Disposal	Compute	If authorized
141-383	Audio/Visual Services Center	660	
141-453	Base Operations	2,000	
141-461	Command Post	2,800	
141-753	Squadron Operations	17,500	
141-786	Deployment Processing	7,900	
171-212	Flight Simulator	Compute	If authorized
171-443	Reserve Forces General Training	Compute	Honor Guard, services, weather, or ALCE flight if authorized
171-445	Reserve Forces Operations & Training	16,800	
171-450	Medical Training	10,300	4000 SF if joint use
171-475	Range, Small Arms, Indoor		Coordinate for approval. See CATCODE, and see 179-475, either/or not both.
171-476	Combat Arms Training & Maintenance (CATM)	1,050	If authorized with range, see CATCODE
171-875	Weapons Loading Crew Training	7,900	Increase to 8,300 SF if stand-alone

Cat Code	Nomenclature	ANGH 32-1084 Authorization	Remarks (F-22)
179-475	Small Arms Range (Firing Points)		Coordinate for approval. See CATCODE, and see 171-475, either/or not both
211-111	Aircraft Maintenance Hangar	28,000	For new construction medium or large hangar area
211-152	General Purpose Maintenance Shops	12,700	
211-153	Non-Destructive Inspection	2,800	
211-154	Aircraft Maintenance Unit (AMU) Shop	9,000	
211-157	Aircraft Engine Maintenance Shop	Compute	See CATCODE
211-159	Corrosion Control		Under Review
211-179	Fuel Systems Maintenance Dock	10,000	
	External Wing Tank Storage Area (SY)	Compute	Use CATCODE 132-133, Equipment Pad for Tank Storage
214-425	Vehicle Maintenance Shop	Compute	Based on vehicle equivalents
214-426	Vehicle Operations Heated Parking	Compute	Based on unit requirements
214-428	Vehicle Operations Parking Shed	Compute	Based on number of vehicles
214-467	Refueler Vehicle Maintenance	1,500	
215-552	Weapons Release	14,400	
216-642	Conventional Munitions Maintenance Shop	16,000	Includes 2,900 SF of Admin
217-712	Avionics Shop	9,200	
217-713	ECM Pod Shop/Storage	Compute	See CATCODE
218-712	Aircraft Support Equipment (ASE)	Compute	Based on pieces of equipment
219-943	BCE Pavements & Grounds	Compute	Based on unit tasking
219-944	Base Civil Engineer Maintenance Shop	5,400	
219-947	Civil Engineer Storage Building	4,000	
422-258	Above Ground Magazine Storage	6,140	
422-264	Igloo Storage	3,600	See CATCODE
442-257	Base Hazardous Storage	1,800	
442-258	LOX/LIN Storage	210	
442-628	Base Supply & Equipment Shed	2,500	

Cat Code	Nomenclature	ANGH 32-1084 Authorization	Remarks (F-22)
442-758	Base Supply Warehouse	21,200	
452-252	Supply Open Storage (SY)	600	
452-255	BCE Open Storage (SY)	3,600	Not to exceed 3,600, build to need not to maximum
610-121	Vehicle Operations Administration	1,900	
610-122	Base Supply Administration	5,000	
610-127	BCE Administration	4,800	(Prime BEEF)
610-129	Weapon System Maintenance Management	7,300	
610-287	Specified Headquarters	Compute	Based on category - if authorized
610-913	Air Base Operability	Compute	Based on authorized personnel
722-351	Dining Hall	Compute	Based on authorized personnel
730-835	Security Forces Operations	Compute	Based on authorized personnel
730-839	Traffic Gatehouse and Guard Booth	300	Main gatehouse
730-839	Access Control Facility (Guard Booth)	32	Main gate guard booth when used
740-674	Physical Fitness Center	Compute	Based on authorized personnel
852-261	Vehicle Operations Parking (SY)	Compute	As required by GOV's
851-262	Non-Organizational Parking (SY)	Compute	75% UTA (35 SY/vehicle)
852-269	Refueler Vehicle Parking (SY)	Compute	600 SY/authorized vehicle

15.1.5 The total authorized areas for the F-35 weapon system is listed in Table 14.4.

Table 15-5: F-35 Fighter Unit.

Cat Code	Nomenclature	ANGH 32-1084 Authorization	Remarks (F-35)
113-321	Apron (Square Yards)	Compute	Based on PAA
116-661	Arm/Disarm Pad (Each)	Compute	Based on PAA
116-665	Power Check Pad (Each)	1	With suppressor
116-672	Wash Rack (Each)		By Exception, See CATCODE Included in 211-111 or 211-179
116-922	Arresting System (Each)	2	
121-111	POL Operations	1,500	Based on UTA personnel
124-134	Operating Storage - Diesel (Gallons)	5,000	
124-135	POL Storage (Gallons/Barrels)	105,000/2,500	Up to 24 PAA
124-137	Operating Storage - MOGAS (Gallons)	5,000	
125-977	Pumping Station	1,500	
126-925	Truck Fill Stand (OL)	2	
126-926	Truck Unloading Stand (OL)	2	
130-142	Fire Crash/Rescue Station	Compute	See CATCODE
131-111	Communications	10,200	
141-165	Explosive Ordnance Disposal	Compute	If authorized
141-383	Audio/Visual Services Center	660	
141-453	Base Operations	2,000	
141-461	Command Post	2,800	
141-753	Squadron Operations	17,500	
141-786	Deployment Processing	7,900	
171-212	Flight Simulator	Compute	If authorized
171-443	Reserve Forces General Training	Compute	Honor Guard, services, weather, or ALCE flight if authorized
171-445	Reserve Forces Operations & Training	16,800	
171-450	Medical Training	10,300	4000 SF if joint use
171-475	Range, Small Arms, Indoor		Coordinate for approval. See CATCODE, and see 179-475, either/or not both.
171-476	Combat Arms Training & Maintenance (CATM)	1,050	If authorized with range, see CATCODE
171-875	Weapons Loading Crew Training	7,900	Increase to 8,300 SF if stand-alone

Cat Code	Nomenclature	ANGH 32-1084 Authorization	Remarks (F-35)
179-475	Small Arms Range (Firing Points)		Coordinate for approval. See CATCODE, and see 171-475, either/or not both
211-111	Aircraft Maintenance Hangar	28,000	For new construction medium or large hangar area
211-152	General Purpose Maintenance Shops	12,700	
211-153	Non-Destructive Inspection	2,800	
211-154	Aircraft Maintenance Unit (AMU) Shop	9,000	
211-157	Aircraft Engine Maintenance Shop	4,700	
211-159	Corrosion Control		Under Review
211-179	Fuel Systems Maintenance Dock	10,000	
	External Wing Tank Storage Area (SY)	Compute	Use CATCODE 132-133, Equipment Pad for Tank Storage
214-425	Vehicle Maintenance Shop	Compute	Based on vehicle equivalents
214-426	Vehicle Operations Heated Parking	Compute	Based on unit requirements
214-428	Vehicle Operations Parking Shed	Compute	Based on number of vehicles
214-467	Refueler Vehicle Maintenance	1,500	
215-552	Weapons Release	14,400	
216-642	Conventional Munitions Maintenance Shop	16,700	Includes 3,600 SF of Admin
217-712	Avionics Shop	9,200	
217-713	ECM Pod Shop/Storage	Compute	See CATCODE
218-712	Aircraft Support Equipment (ASE)	Compute	Based on pieces of equipment
219-943	BCE Pavements & Grounds	Compute	Based on unit tasking
219-944	Base Civil Engineer Maintenance Shop	5,400	
219-947	Civil Engineer Storage Building	4,000	
422-258	Above Ground Magazine Storage	6,140	
422-264	Igloo Storage	3,600	See CATCODE
442-257	Base Hazardous Storage	1,800	
442-258	LOX/LIN Storage	210	
442-628	Base Supply & Equipment Shed	2,500	

Cat Code	Nomenclature	ANGH 32-1084 Authorization	Remarks (F-35)
442-758	Base Supply Warehouse	21,200	
452-252	Supply Open Storage (SY)	600	
452-255	BCE Open Storage (SY)	3,600	Not to exceed 3,600, build to need not to maximum
610-121	Vehicle Operations Administration	1,900	
610-122	Base Supply Administration	5,000	
610-127	BCE Administration	4,800	(Prime BEEF)
610-129	Weapon System Maintenance Management	Compute	See CATCODE
610-287	Specified Headquarters	Compute	Based on category - if authorized
610-913	Air Base Operability	Compute	Based on authorized personnel
722-351	Dining Hall	Compute	Based on authorized personnel
730-835	Security Forces Operations	Compute	Based on authorized personnel
730-839	Traffic Gatehouse and Guard Booth	300	Main gatehouse
730-839	Access Control Facility (Guard Booth)	32	Main gate guard booth when used
740-674	Physical Fitness Center	Compute	Based on authorized personnel
852-261	Vehicle Operations Parking (SY)	Compute	As required by GOV's
851-262	Non-Organizational Parking (SY)	Compute	75% UTA (35 SY/vehicle)
852-269	Refueler Vehicle Parking (SY)	Compute	600 SY/authorized vehicle

15.1.6 The total authorized areas for the C-130 weapon system is listed in Table 14.5.

Table 15-6: C-130 Airlift Unit.

Category Code	Nomenclature	ANGH 32-1084 Authorization	Remarks (C-130)
113-321	Apron (Square Yards)	Compute	Based on PAA
116-664	Unsuppressed Power Check Pad (Each)	1	
116-666	Warm-Up/Holding Pad (Each)	1	Must hold 2 aircraft
116-672	Wash Rack (Each)	1	Included in 211-111 or 211-179
121-111	POL Operations	1,500	Based on UTA personnel
124-134	Operating Storage - Diesel (Gallons)	5,000	
124-135	POL Storage (Gallons/Barrels)	105,000/2,500	Up to 12 PAA
124-137	Operating Storage - MOGAS (Gallons)	5,000	
125-977	Pumping Station	1,200	
126-925	Truck Fill Stand (OL)	2	
126-926	Truck Unloading Stand (OL)	2	
130-142	Fire Crash/Rescue Station	Compute	See CATCODE
131-111	Communications	10,200	
141-165	Explosive Ordnance Disposal (EOD)	Compute	If authorized
141-383	Audio/Visual Services Center	660	
141-453	Base Operations	2,000	
141-461	Command Post	2,800	
141-753	Squadron Operations	Compute	See CATCODE
141-783	Small Air Terminal	13,200	If Authorized
141-786	Deployment Processing	2,700	With SAT
171-212	Flight Simulator	Compute	If authorized
171-443	Reserve Forces General Training	Compute	Honor Guard, services, weather, or ALCE flight authorization
171-445	Reserve Forces Operations & Training	16,800	
171-449	Aeromed Evacuation Training	Compute	If authorized - includes storage
171-450	Medical Training	10,300	4000 SF if joint use
171-475	Range, Small Arms, Indoor		Coordinate for approval. See CATCODE, and see 179-475, either/or not both.
171-476	Combat Arms Training & Maintenance (CATM)	1,050	If authorized with range, see CATCODE

Category Code	Nomenclature	ANGH 32-1084 Authorization	Remarks (C-130)
179-475	Small Arms Range (Firing Points)		Coordinate for approval. See CATCODE, and see 171-475, either/or not both
211-177	Aircraft Maintenance Hangar	23,000	Up to 12 PAA- 1 covered space, see CATCODE
211-152	General Purpose (GP) Maintenance Shops	19,400	
211-153	Non-Destructive Inspection (NDI)	2,200	
211-154	Aircraft Maintenance Unit (AMU) Shop	7,700	
211-157	Aircraft Engine Maintenance Shop	Compute	See CATCODE
211-159	Corrosion Control	Compute	See CATCODE
211-179	Fuel Systems Maintenance Dock	23,700	Aircraft dock and shops
214-425	Vehicle Maintenance Shop	Compute	Based on vehicle equivalents
214-426	Vehicle Operations Heated Parking	Compute	Based on unit requirements
214-428	Vehicle Operations Parking Shed	Compute	Based on number of vehicles
214-467	Refueler Vehicle Maintenance	1,500	
217-712	Avionics Shop	6,400	
217-713	ECM Pod Shop/Storage	2,700	
218-712	Aircraft Support Equipment (ASE)	Compute	Based on pieces of equipment
219-943	BCE Pavements & Grounds	Compute	Based on unit tasking
219-944	Base Civil Engineer Maintenance Shop	5,400	
219-947	Civil Engineer Storage Building	4,000	(Prime BEEF)
422-258	Above Ground Magazine Storage	1,800	includes WRM
422-264	Igloo Storage	Compute	See CATCODE
442-257	Base Hazardous Storage	1,800	
442-258	LOX/LIN Storage	210	
442-628	Base Supplies and Equipment Shed	2,500	
442-758	Base Supply Warehouse	17,900	
452-252	Supply Open Storage (SY)	600	
452-255	BCE Open Storage (SY)	3,600	Not to exceed 3,600, build to need not to maximum

Category Code	Nomenclature	ANGH 32-1084 Authorization	Remarks (C-130)
610-121	Vehicle Operations Administration	1,900	Based on authorized personnel
610-122	Base Supply Administration	5,000	
610-127	BCE Administration	4,800	(Prime BEEF)
610-129	Weapon System Maintenance Management	7,000	
610-287	Specified Headquarters	Compute	Based on authorized personnel
610-913	Air Base Operability	Compute	Based on authorized personnel
722-351	Dining Hall	Compute	Based on authorized personnel
730-835	Security Forces Operations	Compute	Based on authorized personnel
730-839	Traffic Gatehouse and Guard Booth	300	Main gatehouse
730-839	Access Control Facility (Guard Booth)	32	Main gate guard booth when used
740-674	Physical Fitness Center	Compute	Based on authorized personnel
852-261	Vehicle Operations Parking (SY)	Compute	As required by GOV's
851-262	Non-Organizational Parking (SY)	Compute	75% of UTA strength x 35 SY/vehicle
852-269	Refueler Vehicle Parking (SY)	Compute	600 SY/authorized vehicle

15.1.7 The total authorized areas for the C-17 weapon system is listed in Table 14.6.

Table 15-7: C-17 Airlift Unit.

Category Code	Nomenclature	ANGH 32-1084 Authorization	Remarks (C-17)
113-321	Apron (Square Yards)	Compute	Based on 8 PAA - 5 auth aircraft parking positions
116-666	Warm-Up/Holding Pad (Each)	1	Must hold 2 aircraft
116-672	Wash Rack (Each)	1	Included in 211-111, 211-159, or 211-179
121-111	POL Operations	1,500	Based on UTA personnel
121-122	Hydrant Fueling System (OL)	5	1 hydrant PIT/authorized aircraft parking position
121-124	Hydrant Fueling Building	Compute	See CATCODE
124-134	Operating Storage - Diesel (Gallons)	5,000	
124-135	POL Storage (Gallons/Barrels)	315,000/7,500	Authorized if no pipeline - up to 12 PAA
124-137	Operating Storage - MOGAS (Gallons)	5,000	
126-925	Truck Fill Stand (OL)	2	Backup
126-926	Truck Unloading Stand (OL)	2	Backup if on pipeline
130-142	Fire Crash/Rescue Station	Compute	
131-111	Communications	10,200	
141-165	Explosive Ordnance Disposal (EOD)	Compute	If authorized
141-383	Audio/Visual Services Center	660	
141-453	Base Operations	2,000	
141-461	Command Post	2,800	
141-753	Squadron Operations	22,600	
141-783	Small Air Terminal	13,000	
141-786	Deployment Processing	2,700	
171-212	Simulator Training	Compute	See CATCODE
171-443	Reserve Forces General Training	Compute	Honor Guard, services, weather, or ALCE flight authorization
171-445	Reserve Forces Operations & Training	16,800	
171-449	Aeromedical Evacuation Training	Compute	If authorized - includes storage
171-450	Medical Training	10,300	4000 SF if joint use
171-475	Range, Small Arms, Indoor		Coordinate for approval. See CATCODE, and see 179-475, either/or not both.

Category Code	Nomenclature	ANGH 32-1084 Authorization	Remarks (C-17)
171-476	Combat Arms Training & Maintenance (CATM)	1,050	If authorized with range, see CATCODE
179-475	Small Arms Range (Firing Points)		Coordinate for approval. See CATCODE, and see 171-475, either/or not both
211-173	Aircraft Maintenance Hangar	39,500	Up to 8 PAA - 1 covered space
211-152	General Purpose (GP) Maintenance Shops	20,000	
211-153	Non-Destructive Inspection	4,000	
211-154	Aircraft Maint Unit (AMU) Shop	7,700	
211-157	Aircraft Engine Maintenance Shop	9,500	Up to 8 PAA - 2000 SF covered storage included
211-159	Corrosion Control	10,000	10,000 SF includes Composites, Corrosion Control Shop, and clean/dirty operations.
211-179	Fuel Systems Maintenance Dock	42,000	Up to 8 PAA- 1 covered space – Aircraft dock and shops.
214-425	Vehicle Maintenance Shop	Compute	Based on vehicle equivalents
214-426	Vehicle Operations Heated Parking	Compute	Based on unit requirements
214-428	Vehicle Operations Parking Shed	Compute	Based on number of vehicles
214-467	Refueler Vehicle Maint	1,500	For hydrant hose carts/trucks
217-712	Avionics Shop	5,400	
217-713	ECM Pod Shop/Storage	2,700	
218-712	Aircraft Support Equipment (ASE)	Compute	Based on pieces of equipment
219-943	BCE Pavements & Grounds	Compute	Based on unit tasking
219-944	Base Civil Engineer Maintenance Shop	5,400	
219-947	Civil Engineer Storage Building	4,000	
422-258	Above Ground Magazine Storage	1,800	includes WRM
422-264	Igloo Storage	Compute	See CATCODE
442-257	Base Hazardous Storage	1,800	
442-258	LOX/LIN Storage	210	
442-628	Base Supplies and Equipment Shed	2,500	
442-758	Base Supply Warehouse	28,200	
452-252	Supply Open Storage (SY)	600	
452-255	BCE Open Storage (SY)	3,600	Not to exceed 3,600, build to need not to maximum

Category Code	Nomenclature	ANGH 32-1084 Authorization	Remarks (C-17)
610-121	Vehicle Operations Administration	1,900	Based on authorized personnel
610-122	Base Supply Administration	5,000	
610-123	Contractor Support Area	Compute	Base supply/flight line If authorized
610-127	BCE Administration	4,800	(Prime BEEF)
610-129	Weapon System Maintenance Management	7,000	
610-287	Specified Headquarters	Compute	Based on authorized personnel
610-913	Air Base Operability	Compute	Based on authorized personnel
722-351	Dining Hall	Compute	Based on authorized personnel
730-835	Security Forces Operations	Compute	Based on authorized personnel
730-839	Traffic Gatehouse and Guard Booth	300	Main gatehouse
730-839	Access Control Facility (Guard Booth)	32	Main gate guard booth when used
740-674	Physical Fitness Center	Compute	Based on authorized personnel
852-261	Vehicle Operations Parking (SY)	Compute	As required by GOV's
851-262	Non-Organizational Parking (SY)	Compute	POV's - 75% of UTA strength x 35 SY/vehicle
852-269	Refueler Vehicle Parking (SY)	Compute	600 SY/auth vehicle - refueler, hose cart/truck

15.1.8 The total authorized areas for the KC-135-R weapon system is listed in Table 14.7

Table 15-8: KC-135-R Refueling Airlift Unit.

Category Code	Nomenclature	ANGH 32-1084 Authorization	Remarks (KC-135)
113-321	Apron (Square Yards)	Compute	Based on PAA
116-664	Unsuppressed Power Check Pad (each)	1	
116-666	Warm-Up/Holding Pad (each)	1	Must hold 2 aircraft
116-672	Wash Rack (each)	1	Included in 211-111 or 211-179
121-111	POL Operations	1,500	Based on UTA personnel
124-134	Operating Storage - Diesel (Gallons)	5,000	
124-135	POL Storage (Gallons/Barrels)	420,000/10,000	Up to 12 PAA
124-137	Operating Storage - MOGAS (Gallons)	5,000	
125-977	Pumping Station	1,200	
126-925	Truck Fill Stand (OL)	2	
126-926	Truck Unloading Stand (OL)	2	
130-142	Fire Crash/Rescue Station	Compute	
131-111	Communications	10,200	
141-165	Explosive Ordnance Disposal (EOD)	Compute	If authorized
141-383	Audio/Visual Services Center	660	
141-453	Base Operations	2,000	
141-461	Command Post	2,800	
141-753	Squadron Operations	Compute	See CATCODE
141-783	Small Air Terminal	5,700	If Authorized
141-786	Deployment Processing	2,700	With SAT
171-212	Flight Simulator	Compute	If authorized
171-443	Reserve Forces General Training	Compute	Honor Guard, services, weather, or ALCE flight auth
171-445	Reserve Forces Operations & Training	16,800	
171-449	Aeromed Evacuation Training	Compute	If authorized - includes storage
171-450	Medical Training	10,300	4000 SF if joint use
171-475	Range, Small Arms, Indoor		Coordinate for approval. See CATCODE, and see 179-475, either/or not both.

Category Code	Nomenclature	ANGH 32-1084 Authorization	Remarks (KC-135)
171-476	Combat Arms Training & Maintenance (CATM)	1,050	If authorized with range, see CATCODE
179-475	Small Arms Range (Firing Points)		Coordinate for approval. See CATCODE, and see 171-475, either/or not both
211-111	Aircraft Maintenance Hangar	28,000	Up to 12 PAA - 1 covered space, see CATCODE for new construction
211-152	General Purpose (GP) Maintenance Shops	19,400	
211-153	Non-Destructive Inspection (NDI)	2,600	
211-154	Aircraft Maintenance Unit (AMU) Shop	7,700	
211-157	Aircraft Engine Maintenance Shop	3,700	
211-159	Corrosion Control	4,600	
211-179	Fuel Systems Maintenance Dock	30,500	Aircraft dock and shops, see CATCODE for new construction
214-425	Vehicle Maintenance Shop	Compute	Based on vehicle equivalents
214-426	Vehicle Operations Heated Parking	Compute	Based on unit requirements
214-428	Vehicle Operations Parking Shed	Compute	Based on number of vehicles
214-467	Refueler Vehicle Maintenance	1,500	
217-712	Avionics Shop	5,400	
218-712	Aircraft Support Equipment (ASE)	Compute	Based on pieces of equipment
219-943	BCE Pavements & Grounds	Compute	Based on unit tasking
219-944	Base Civil Engineer Maintenance Shop	5,400	
219-947	Civil Engineer Storage Building	4,000	(Prime BEEF)
422-258	Above Ground Magazine Storage	1,800	includes WRM
422-264	Igloo Storage	Compute	See CATCODE
442-257	Base Hazardous Storage	1,800	
442-258	LOX/LIN Storage	210	
442-628	Base Supplies and Equipment Shed	2,500	
442-758	Base Supply Warehouse	17,900	
452-252	Supply Open Storage (SY)	600	

Category Code	Nomenclature	ANGH 32-1084 Authorization	Remarks (KC-135)
452-255	BCE Open Storage (SY)	3,600	Not to exceed 3,600, build to need not to maximum
610-121	Vehicle Operations Administration	1,900	Based on authorized personnel
610-122	Base Supply Administration	5,000	
610-127	BCE Administration	4,800	(Prime BEEF)
610-129	Weapon System Maintenance Management	6,900	
610-287	Specified Headquarters	Compute	Based on authorized personnel
610-913	Air Base Operability	Compute	Based on authorized personnel
722-351	Dining Hall	Compute	Based on authorized personnel
730-835	Security Forces Operations	Compute	Based on authorized personnel
730-839	Traffic Gatehouse and Guard Booth	300	Main gatehouse
730-839	Access Control Facility (Guard Booth)	32	Main gate guard booth when used
740-674	Physical Fitness Center	Compute	Based on authorized personnel
852-261	Vehicle Operations Parking (SY)	Compute	As required by GOV's
851-262	Non-Organizational Parking (SY)	Compute	75% of UTA strength x 35 SY/vehicle
852-269	Refueler Vehicle Parking (SY)	Compute	600 SY/authorized vehicle

15.1.9 The total authorized areas for the KC-46 weapon system is listed in Table 14.8.

Table 15-9: KC-46 Refueling Airlift Unit.

Category Code	Nomenclature	ANGH 32-1084 Authorization	Remarks (KC-46)
113-321	Apron (Square Yards)	Compute	Based on PAA
116-664	Unsuppressed Power Check Pad (each)	1	
116-666	Warm-Up/Holding Pad (each)	1	Must hold 2 aircraft
116-672	Wash Rack (each)	1	Included in 211-111 or 211-179
121-111	POL Operations	2,800	Based on UTA personnel
124-134	Operating Storage - Diesel (Gallons)	5,000	
124-135	POL Storage (Gallons/Barrels)	420,000/10,000	Up to 12 PAA
124-137	Operating Storage - MOGAS (Gallons)	5,000	
125-977	Pumping Station	1,200	
126-925	Truck Fill Stand (OL)	2	
126-926	Truck Unloading Stand (OL)	2	
130-142	Fire Crash/Rescue Station	Compute	
131-111	Communications	10,200	
141-165	Explosive Ordnance Disposal (EOD)	Compute	If authorized
141-383	Audio/Visual Services Center	660	
141-453	Base Operations	2,000	
141-461	Command Post	2,800	
141-753	Squadron Operations	Compute	See CATCODE
141-783	Small Air Terminal	12,400	Includes increased storage needs
141-786	Deployment Processing	2,700	With SAT
171-212	Flight Simulator	Compute	FuT 10,075SF, WST 5,800SF, BOT 1,100SF, and CATS 1,200SF would give a total of 18,175 SF for 171-212 (add in each if assigned and needed to get total)
171-443	Reserve Forces General Training	Compute	Honor Guard, services, weather, or ALCE flight auth
171-445	Reserve Forces Operations & Training	16,800	
171-449	Aeromed Evacuation Training	Compute	If authorized - includes storage
171-450	Medical Training	10,300	4000 SF if joint use

Category Code	Nomenclature	ANGH 32-1084 Authorization	Remarks (KC-46)
171-475	Range, Small Arms, Indoor		Coordinate for approval. See CATCODE, and see 179-475, either/or not both.
171-476	Combat Arms Training & Maintenance (CATM)	1,050	If authorized with range, see CATCODE
179-475	Small Arms Range (Firing Points)		Coordinate for approval. See CATCODE, and see 171-475, either/or not both
211-111	Aircraft Maintenance Hangar	34,500	Up to 12 PAA - 1 covered space, see CATCODE for new construction
211-152	General Purpose (GP) Maintenance Shops	23,500	
211-153	Non-Destructive Inspection (NDI)	3,000	
211-154	Aircraft Maintenance Unit (AMU) Shop	10,100	
211-157	Aircraft Engine Maintenance Shop	3,600	
211-159	Corrosion Control	10,000	
211-179	Fuel Systems Maintenance Dock	37,000	Aircraft dock and shops
214-425	Vehicle Maintenance Shop	Compute	Based on vehicle equivalents
214-426	Vehicle Operations Heated Parking	Compute	Based on unit requirements
214-428	Vehicle Operations Parking Shed	Compute	Based on number of vehicles
214-467	Refueler Vehicle Maintenance	1,500	
217-712	Avionics Shop	3,100	
218-712	Aircraft Support Equipment (ASE)	Compute	Based on pieces of equipment
219-943	BCE Pavements & Grounds	Compute	Based on unit tasking
219-944	Base Civil Engineer Maintenance Shop	5,400	
219-947	Civil Engineer Storage Building	4,000	(Prime BEEF)
422-258	Above Ground Magazine Storage	1,800	includes WRM
422-264	Igloo Storage	Compute	See CATCODE
442-257	Base Hazardous Storage	1,800	
442-258	LOX/LIN Storage	210	

Category Code	Nomenclature	ANGH 32-1084 Authorization	Remarks (KC-46)
442-628	Base Supplies and Equipment Shed	2,500	
442-758	Base Supply Warehouse	21,600	Active Association
452-252	Supply Open Storage (SY)	600	
452-255	BCE Open Storage (SY)	3,600	Not to exceed 3,600, build to need not to maximum
610-121	Vehicle Operations Administration	1,900	Based on authorized personnel
610-122	Base Supply Administration	5,000	
610-127	BCE Administration	4,800	(Prime BEEF)
610-129	Weapon System Maintenance Management	6,900	
610-287	Specified Headquarters	Compute	Based on authorized personnel
610-913	Air Base Operability	Compute	Based on authorized personnel
722-351	Dining Hall	Compute	Based on authorized personnel
730-835	Security Forces Operations	Compute	Based on authorized personnel
730-839	Traffic Gatehouse and Guard Booth	300	Main gatehouse
730-839	Access Control Facility (Guard Booth)	32	Main gate guard booth when used
740-674	Physical Fitness Center	Compute	Based on authorized personnel
852-261	Vehicle Operations Parking (SY)	Compute	As required by GOV's
851-262	Non-Organizational Parking (SY)	Compute	75% of UTA strength x 35 SY/vehicle
852-269	Refueler Vehicle Parking (SY)	Compute	600 SY/authorized vehicle

15.1.10 The total authorized areas for the ANG Combat Readiness Training Center (CRTC) is listed in Table 14.9.

Table 15-10: ANG Combat Readiness Training Center (CRTC) Facility Requirements Programming Guide.

Cat Code	Nomenclature	ANGH32-1084 Authorization	Remarks (CRTC)
113-321	Apron (Square Yards)		(Contact NGB/A4)
121-111	POL Operations Building	1,500	
123-335	Vehicle Fueling Station (OL)	2	
124-134	Operating Storage – Diesel (Gallons)	5,000	
124-135	Operating Storage – Jet Fuel (Gallons/Barrels)	420,000/10,000	
124-137	Operating Storage – MOGAS (Gallons)	5,000	
125-977	Pumping Station	1,200	
126-925	Truck Fill Stand (OL)	2	
126-926	Truck Unloading Stand (OL)	2	
130-142	Fire Crash/Rescue Station	Compute	
131-111	Telecommunications Facility	Compute	
134-375	RAPCON Facility		(Contact NGB/A4)
141-383	Audio/Visual Services Center	660	
141-453	Base Operations	2,000	
141-753	Squadron Operations	15,200	7,600 SF for Cadre and 7,600 SF for visiting units in separate facilities
171-212	ACMI/ACTS (Flight Simulator) Facility		(Contact NGB/A4)
171-443	Reserve Forces General Training	Compute	Honor Guard, services, weather, or ALCE if authorized
171-445	Reserve Forces Operations & Training (O&T)	25,000	CRTC area 2,000 Net SF
171-450	Reserve Component Medical Training	5,800	2,700 SF – host 3,100 SF – visiting units
171-475	Range, Small Arms, Indoor		Coordinate for approval. See CATCODE, and see 179-475, either/or not both.
171-476	Combat Arms Training & Maintenance (CATM)	1,050	If authorized with range, see CATCODE
179-475	Small Arms Range (Firing Points)		Coordinate for approval. See CATCODE, and see 171-475, either/or not both

Cat Code	Nomenclature	ANGH32-1084 Authorization	Remarks (CRTC)
179-511	Firefighter Training Facility	1 each	Support building 1,600 SF
211-111	Aircraft Maintenance Hangar	20,000	Also functions as Fuel Cell/Corrosion Control
211-152	General Purpose (GP) Maintenance Shops	4,000	
211-153	Non-Destructive Inspection	400	
211-154	Aircraft Maintenance Unit (AMU) Shop	4,000	
214-425	Vehicle Maintenance Shop	Compute	Based on vehicle equivalents
214-426	Vehicle Operations Heated Parking	Compute	Based on unit requirements
214-428	Vehicle Operations Parking Shed	Compute	Based on number of vehicles including U-drive-it fleet
214-467	Refueler Vehicle Maintenance	1,500	
216-642	Conventional Munitions Maintenance Shop	12,800	
217-712	Avionics Shop	3,000	
218-712	Aircraft Support Equipment (ASE)	Compute	Based on pieces of equipment
219-943	BCE Pavements & Grounds	Compute	Based on unit tasking
219-944	Base Civil Engineer Maintenance Shop	3,000	
219-947	Civil Engineer Storage Building	5,000	
422-258	Above Ground Magazine Storage	2,000	
422-264	Igloo Storage	3,600	
442-257	Base Hazardous Storage	1,800	
442-258	LOX/LIN Storage	210	
442-628	Base Supplies & Equipment Shed	8,000	
442-758	Base Supply Warehouse	18,000	
452-252	Supply Open Storage (SY)	600	
452-255	BCE Open Storage (SY)	3,600	Not to exceed 3,600, build to need not to maximum
610-121	Vehicle Operations Administration	Compute	Based on authorized personnel
610-122	Base Supply Administration	1,500	
610-127	BCE Administration	3,600	
610-129	Weapon System Maintenance Management		Contact NGB/A4

Cat Code	Nomenclature	ANGH32-1084 Authorization	Remarks (CRTC)
722-351	Dining Hall	8,500	
725-517	Troop Camp (Officer)	115 personnel	
725-517	Troop Camp (Enlisted)	635 personnel	
730-835	Security Forces Operations	8,900	3,000 SF – host 5,900 SF – visiting unit
730-839	Security Entry Control Building		See corresponding category code.
740-674	Physical Fitness Center	3,000	Full-time CRTC personnel and visiting unit(s)
852-261	Vehicle Operations Parking (SY)	Compute	As required by GOV's
851-262	Non-Organizational Parking (SY)	Compute	35 SY/vehicle
852-269	Refueler Vehicle Parking (SY)	Compute	600 SY/authorized vehicle

15.1.11 The total authorized areas for the ANG RED HORSE Unit is listed in Table 14.10

Table 15-11: ANG RED HORSE Unit Facility Requirements Programming Guide (“1/2 RED HORSE squadron of 210 personnel” and “1/4 RED HORSE of 130 personnel” with equipment and vehicle packages.

Cat Code	Nomenclature	210 person RHS	130 person RHS	Remarks (RED HORSE)
123-335	Vehicle Fueling Station (OL)	2	2	
131-111	Telecommunications Facility	300	200	
171-445	Reserve Forces Operations & Training (O&T)	7,500	5,000	Use wing O&T when colocated or classic associate
171-445	Range, Small Arms, Indoor			Coordinate for approval. See CATCODE, and see 179-475, either/or not both.
171-476	Combat Arms Training & Maintenance (CATM)	1,050	1,050	Would be colocated with a range if there is no range then no need for CATM, see CATCODE
179-475	Small Arms Range (Firing Points)			Coordinate for approval. See CATCODE, and see 171-475, either/or not both
214-422	Vehicle Wash Rack	1 each	1 each	
214-425	Vehicle Maintenance Shop	5,400	4,900	Based on vehicle equivalents
214-428	Vehicle Operations Parking Shed	8,000	4,000	Based on vehicle equivalents
214-467	Refueler Vehicle Maintenance	800	800	
219-943	BCE Pavements & Grounds	8,000	4,000	Based on unit tasking
219-944	Base Civil Engineer Maintenance Shop	9,400	5,900	
219-947	Civil Engineer Storage Building	9,000	6,800	
442-257	Base Hazardous Storage	600	300	
442-628	Base Supplies and Equipment Shed	8,400	6,200	
442-758	Base Supply and Equipment Warehouse	12,800	8,400	
610-121	Vehicle Operations Administration	700	700	Based on authorized personnel
610-122	Base Supply Administration	1,000	750	
610-127	BCE Administration	2,000	2,000	
610-913	Emergency Management			Under Review
722-351	Dining Hall	4,000	2,000	
725-517	Troop Camp	16,000	6,500	If Authorized
730-837	Security Police Entry Contr Building	Compute	Compute	If Authorized
740-674	Physical Fitness Center	700	700	
852-261	Vehicle Operations Parking (SY)	Compute	Compute	As required by GOV's
851-262	Non-Organizational Parking (SY)	Compute	Compute	75% of UTA strength x 35 SY/vehicle
890-197	Weight Scale	1 each	1 each	

15.1.12 1/2 RED HORSE Squadron and 1/4 RED HORSE Squadron ANG locations.

Table 15-12: ANG 1/2 RED HORSE squadron and 1/4 RED HORSE Assigned Locations

Unit	Location	Unit State/Territory	Assigned as
200 RED HORSE Squadron	CP Perry	Ohio	1/2 RED HORSE Squadron
200 RED HORSE Squadron Det: 0001	Mansfield Lahm	Ohio	1/2 RED HORSE Squadron
201 RED HORSE Squadron	Ft Indiantown Gap	Pennsylvania	1/2 RED HORSE Squadron
201 RED HORSE Squadron Det: 0001	Horsham	Pennsylvania	1/2 RED HORSE Squadron
202 RED HORSE Squadron	CP Blanding	Florida	1/2 RED HORSE Squadron
203 RED HORSE Squadron	CP Pendleton	Virginia	1/2 RED HORSE Squadron
210 RED HORSE Squadron	Kirtland	New Mexico	1/4 RED HORSE Squadron
219 RED HORSE Squadron	Malmstrom	Montana	1/4 RED HORSE Squadron
254 RED HORSE Squadron	Andersen	Guam	1/4 RED HORSE Squadron

Appendices & References:

Appendix A: Weapon System / Mission Reference Guides

A.1 - Stand-Alone Weapon System or Mission

A.1.1 Host support is not required for the weapon system or mission displayed in Table A-1. In most cases, the weapon system or mission is the host on an ANG installation or is a tenant on another DoD installation.

A.1.2 An “X” in the matrix means that this CATCODE normally associated with the Weapon System or Mission shown.

A.1.3 In cases where the remarks section shows “By Exception”, this CATCODE is authorized with NGB/A4F approval.

A.1 STAND-ALONE WEAPON SYSTEM or MISSION																		
CATCODE, Title	FAC Code	A-10 or OA-10 (Fighter)	F-15 or F-16 (Fighter)	F-22 or F-35 (Fighter)	C-17 (Airlift)	C-130 (Airlift)	HC-130/HH-60 (Combat Rescue)	KC-135 (Air Refueling)	KC-46A (Air Refueling)	Remotely Piloted Aircraft (RPA)	MC-12	Combat Readiness Training Center (CRTC)	Distributed Comms Ground Sys (DCGS)	EC-130 (Special Operations)	Advanced Airlift Tactics Trng Center (AATTC)	JOINT STARS	Flying Training Unit (FTU)	Remarks
CATEGORY GROUP 11 - AIRFIELD PAVEMENTS																		
CATCODE 111-111, Runway	1111	X	X	X	X	X	X	X	X	X	X	X		X	X	X	X	
CATCODE 111-115, Paved Overrun	1113	X	X	X	X	X	X	X	X			X		X	X	X	X	
CATCODE 112-211, Taxiway	1121	X	X	X	X	X	X	X	X	X	X	X		X	X	X	X	
CATCODE 113-321, Apron	1131	X	X	X	X	X	X	X	X	X	X	X		X	X	X	X	
CATCODE 116-116, Short Field Take-off and Landing Zone	1111					X				X								
CATCODE 116-642, Paved Shoulders	1165	X	X	X	X	X	X	X	X		X	X		X	X	X	X	
CATCODE 116-661, Arm/Disarm Pad	1131	X	X	X														
CATCODE 116-662, Hazardous Cargo Pad	1131	X	X	X	X	X	X	X	X									By Exception
CATCODE 116-664, Unsuppressed Power Check Pad	1131	X				X	X	X	X		X	X		X	X	X	X	
CATCODE 116-665, Power Check Pad (with Noise Suppressor)	1131	X	X	X								X						
CATCODE 116-666, Warm Up / Holding Pad	1131	X	X	X	X	X	X	X	X		X			X				By Exception
CATCODE 116-667, Compass Calibration Pad	1161	X	X	X	X	X	X	X	X		X	X		X		X	X	By Exception
CATCODE 116-672, Aircraft Wash Rack	1163				X	X	X	X	X		X							By Exception
CATCODE 116-945, Jet Blast Deflector	1464	X	X	X	X	X	X	X	X		X							By Exception
CATEGORY GROUP 12 - PETROLEUM DISPENSING AND OPERATING FACILITIES																		

A.1 STAND-ALONE WEAPON SYSTEM or MISSION																		
CATCODE, Title	FAC Code	A-10 or OA-10 (Fighter)	F-15 or F-16 (Fighter)	F-22 or F-35 (Fighter)	C-17 (Airlift)	C-130 (Airlift)	HC-130/HH-60 (Combat Rescue)	KC-135 (Air Refueling)	KC-46A (Air Refueling)	Remotely Piloted Aircraft (RPA)	MC-12	Combat Readiness Training Center (CRTC)	Distributed Comms Ground Sys (DCGS)	EC-130 (Special Operations)	Advanced Airlift Tactics Trng Center (AATTC)	JOINT STARS	Flying Training Unit (FTU)	Remarks
CATCODE 121-111, Petroleum Operations Building	1444	X	X	X	X	X	X	X	X	X	X	X		X	X	X	X	
CATCODE 121-122, Hydrant Fueling System	1211				X			X	X		X					X		
CATCODE 121-124, Hydrant Fueling Building	1262				X			X	X		X					X		
CATCODE 123-335, Vehicle Fueling Station (Base Service Station)	1231	X	X	X	X	X	X	X	X	X	X	X	X	X	X	X	X	
CATCODE 124-134, Operating Storage, Diesel	1241	X	X	X	X	X	X	X	X	X	X	X		X	X	X	X	
CATCODE 124-135, Operating Storage, Jet Fuel	1241	X	X	X	X	X	X	X	X	X	X	X		X	X	X	X	
CATCODE 124-137, Operating Storage, Motor Gas	1241	X	X	X	X	X	X	X	X	X	X	X	X	X	X	X	X	
CATCODE 125-977, Pump Station, Liquid Fuel	1262	X	X	X	X	X	X	X	X	X	X	X		X	X	X	X	
CATCODE 126-925, Liquid Fuel Truck Fill Stand	1261	X	X	X	X	X	X	X	X	X	X	X		X	X	X	X	
CATCODE 126-926, Liquid Fuel Truck Unloading Stand	1261	X	X	X	X	X	X	X	X	X	X	X		X	X	X	X	
CATEGORY GROUP 13 - COMM, NAV AIDS, AIR TRAFFIC CONTROL, AND AIRFIELD LIGHTING																		
CATCODE 130-142, Fire Crash/Rescue Station	1411	X	X	X	X	X	X	X	X	X	X	X		X	X	X	X	By Exception
CATCODE 131-111, Telecommunications	1311	X	X	X	X	X	X	X	X	X	X	X	X	X	X	X	X	
CATCODE 131-115, Communications Receiver	1311	X	X	X	X	X	X	X	X	X	X	X	X	X	X	X	X	By Exception
CATCODE 131-116, Communications Transmitter/Receiver	1311	X	X	X	X	X	X	X	X	X	X	X		X	X	X	X	By Exception
CATCODE 131-117, Communications Transmitter	1311	X	X	X	X	X	X	X	X	X	X	X		X	X	X	X	By Exception

A.1 STAND-ALONE WEAPON SYSTEM or MISSION																		
CATCODE, Title	FAC Code	A-10 or OA-10 (Fighter)	F-15 or F-16 (Fighter)	F-22 or F-35 (Fighter)	C-17 (Airlift)	C-130 (Airlift)	HC-130/HH-60 (Combat Rescue)	KC-135 (Air Refueling)	KC-46A (Air Refueling)	Remotely Piloted Aircraft (RPA)	MC-12	Combat Readiness Training Center (CRTC)	Distributed Comms Ground Sys (DCGS)	EC-130 (Special Operations)	Advanced Airlift Tactics Trng Center (AATTC)	JOINT STARS	Flying Training Unit (FTU)	Remarks
CATCODE 134-351, Instrument Landing System (ILS) Glide Slope	1343	X	X	X	X	X	X	X	X	X	X	X		X	X	X	X	By Exception
CATCODE 134-353, Instrument Landing System (ILS) Localizer	1343	X	X	X	X	X	X	X	X	X	X	X		X	X	X	X	By Exception
CATCODE 134-376, Airport Surveillance Radar (ASR)	4343	X	X	X	X	X	X	X	X	X	X	X		X	X	X	X	By Exception
CATCODE 134-465, Tactical Air Navigation (TACAN)	1344	X	X	X	X	X	X	X	X	X	X	X		X	X	X	X	By Exception
CATCODE 134-511, VORTAC, Fixed	1345	X	X	X	X	X	X	X	X	X	X	X		X	X	X	X	By Exception
CATCODE 136-661, Approach Lighting	1361	X	X	X	X	X	X	X	X	X	X	X		X	X	X	X	By Exception
CATCODE 136-664, Runway Lighting	1361	X	X	X	X	X	X	X	X	X	X	X		X	X	X	X	By Exception
CATCODE 136-667, Taxiway Lighting	1361	X	X	X	X	X	X	X	X	X	X	X		X	X	X	X	
CATEGORY GROUP 14 - LAND OPERATIONAL FACILITIES																		
CATCODE 141-165, Explosive Ordnance Disposal (EOD) Facility	1444																	By Exception
CATCODE 141-181, Fighter Aircraft Shelter	1466																	By Exception
CATCODE 141-183, Fighter Aircraft Alert Hangar	2111																	By Exception
CATCODE 141-185,	2111						X											By Exception
CATCODE 141-383, Audio / Visual	1441	X	X	X	X	X	X	X	X	X	X	X	X	X	X	X	X	
CATCODE 141-453, Base Operations	1412	X	X	X	X	X	X	X	X	X	X	X	X	X	X	X	X	

A.1 STAND-ALONE WEAPON SYSTEM or MISSION																		
CATCODE, Title	FAC Code	A-10 or OA-10 (Fighter)	F-15 or F-16 (Fighter)	F-22 or F-35 (Fighter)	C-17 (Airlift)	C-130 (Airlift)	HC-130/HH-60 (Combat Rescue)	KC-135 (Air Refueling)	KC-46A (Air Refueling)	Remotely Piloted Aircraft (RPA)	MC-12	Combat Readiness Training Center (CRTC)	Distributed Comms Ground Sys (DCGS)	EC-130 (Special Operations)	Advanced Airlift Tactics Trng Center (AATTC)	JOINT STARS	Flying Training Unit (FTU)	Remarks
CATCODE 141-454 Special Operations	1444												X					By Exception
CATCODE 141-459 Crew Readiness	1412		X	X			X	X	X									
CATCODE 141-461, Command Post	1441	X	X	X	X	X	X	X	X	X		X		X	X	X	X	
CATCODE 141-753, Squadron Operations (Sqd Ops)	1412	X	X	X	X	X	X	X	X	X	X		X	X	X	X		
CATCODE 141-783, Small Air Terminal (SAT)	1412				X	X		X	X									
CATCODE 141-786, Deployment Processing Center	1412	X	X	X	X	X	X	X	X	X	X		X	X	X	X		
CATCODE 149-511, RPA Support Operations Center (SOC)	1495									X								
CATCODE 149-621, Wind Measuring Set (AN/FMQ-13)	1496	X	X	X	X	X	X	X	X	X	X		X	X	X	X		By Exception
CATCODE 134-101, Wind Measurement Equipment	1496	X	X	X	X	X	X	X	X	X	X		X	X	X	X		By Exception
CATCODE 134-102, Automatic Meteorological Station	1496	X	X	X	X	X	X	X	X	X	X		X	X	X	X		By Exception
CATCODE 149-962, Air Traffic Control (ATC) Tower	1413	X	X	X	X	X	X	X	X	X	X		X	X	X	X		By Exception
CATEGORY GROUP 17 - TRAINING FACILITIES																		
CATCODE 171-211, Flying Training Classroom	1711																	By Exception
CATCODE 171-212, Simulator Training	1721	X	X	X	X	X	X	X	X	X	X		X	X	X	X		
CATCODE 171-443, Reserve Forces General Training Support	1714	X	X	X	X	X	X	X	X	X	X	X	X	X	X	X		

A.1 STAND-ALONE WEAPON SYSTEM or MISSION																		
CATCODE, Title	FAC Code	A-10 or OA-10 (Fighter)	F-15 or F-16 (Fighter)	F-22 or F-35 (Fighter)	C-17 (Airlift)	C-130 (Airlift)	HC-130/HH-60 (Combat Rescue)	KC-135 (Air Refueling)	KC-46A (Air Refueling)	Remotely Piloted Aircraft (RPA)	MC-12	Combat Readiness Training Center (CRTC)	Distributed Comms Ground Sys (DCGS)	EC-130 (Special Operations)	Advanced Airlift Tactics Trng Center (AATTC)	JOINT STARS	Flying Training Unit (FTU)	Remarks
CATCODE 171-445, Reserve Forces Operational Training	1714	X	X	X	X	X	X	X	X	X	X	X	X	X	X	X	X	
CATCODE 171-447, Reserve Forces Communications & Electronics Training	1711																	By Exception, See CATCODE
CATCODE 171-449, Reserve Forces Aeromedical Evacuation Training	1711																	By Exception, See CATCODE
CATCODE 171-450, Reserve Forces Medical Training / Administration	5500	X	X	X	X	X	X	X	X	X	X	X	X	X	X	X	X	
CATCODE 171-471, Range Control House (RCH)	1731																	By Excp, See CATCODE
CATCODE 171-472, Range Supply and Equipment Storage	1731																	By Excp, See CATCODE
CATCODE 171-473, Range Target Storage and Repair	1731																	By Excp, See CATCODE
CATCODE 171-475, Range, Small Arms, Indoor	1718																	By Excp, See CATCODE
CATCODE 171-476, Combat Arms Training Maintenance (CATM)	1718	X	X	X	X	X	X	X	X	X	X	X	X	X	X	X	X	
CATCODE 179-475, Small Arms Range, Outdoor	1750																	By Excp, See CATCODE
CATCODE 179-481, Aircraft Range	1793																	By Exception
CATCODE 179-511, Fire Fighter Training Facility	1795											X						By Excp, See Appendix A.2

A.1 STAND-ALONE WEAPON SYSTEM or MISSION																		
CATCODE, Title	FAC Code	A-10 or OA-10 (Fighter)	F-15 or F-16 (Fighter)	F-22 or F-35 (Fighter)	C-17 (Airlift)	C-130 (Airlift)	HC-130/HH-60 (Combat Rescue)	KC-135 (Air Refueling)	KC-46A (Air Refueling)	Remotely Piloted Aircraft (RPA)	MC-12	Combat Readiness Training Center (CRTC)	Distributed Comms Ground Sys (DCGS)	EC-130 (Special Operations)	Advanced Airlift Tactics Trng Center (AATTC)	JOINT STARS	Flying Training Unit (FTU)	Remarks
CATEGORY GROUP 21 - MAINTENANCE FACILITIES																		
CATCODE 211-173, Large Aircraft Maintenance Dock	2111		X	X	X			X	X							X	X	
CATCODE 211-175, Medium Aircraft Maintenance Dock for Fighters	2111		X	X													X	Either or
CATCODE 211-177, Small Aircraft Maintenance Dock, C-130J-30 and smaller aircraft	2111					X	X			X	X	X		X				
CATCODE 211-152, Aircraft General Purpose Shops	2112	X	X	X	X	X	X	X	X	X	X	X		X	X	X	X	
CATCODE 211-153, Non-Destructive Inspection Shop	2112	X	X	X	X	X	X	X	X	X	X	X		X	X	X	X	
CATCODE 211-154, Aircraft Organizational Maintenance Shop (AMU)	2112	X	X	X	X	X	X	X	X	X	X	X		X	X	X	X	
CATCODE 211-157, Jet Engine Inspection and Maintenance Shop	2116																	By Excp, See CATCODE
CATCODE 211-159, Aircraft Corrosion Control	2113																	By Excp, See CATCODE
CATCODE 211-161, Corrosion Control Utility Storage	4423				X	X	X	X			X							
CATCODE 211-179, Fuel System Maintenance Dock	2111	X	X	X	X	X	X	X	X	X	X	X		X	X	X	X	
CATCODE 211-193, Test Stand	2118	X	X	X	X	X	X	X	X	X	X	X		X	X	X	X	
CATCODE 214-422, Vehicle Service Rack	2145	X	X	X	X	X	X	X	X	X	X	X		X	X	X	X	
CATCODE 214-425, Vehicle Maintenance Shop	2141	X	X	X	X	X	X	X	X	X	X	X	X	X	X	X	X	Chk Vehicle Equivalence

A.1 STAND-ALONE WEAPON SYSTEM or MISSION																		
CATCODE, Title	FAC Code	A-10 or OA-10 (Fighter)	F-15 or F-16 (Fighter)	F-22 or F-35 (Fighter)	C-17 (Airlift)	C-130 (Airlift)	HC-130/HH-60 (Combat Rescue)	KC-135 (Air Refueling)	KC-46A (Air Refueling)	Remotely Piloted Aircraft (RPA)	MC-12	Combat Readiness Training Center (CRTC)	Distributed Comms Ground Sys (DCGS)	EC-130 (Special Operations)	Advanced Airlift Tactics Trng Center (AATTC)	JOINT STARS	Flying Training Unit (FTU)	Remarks
CATCODE 214-426, Vehicle Operations Heated Parking	4425																	By Excp, See CATCODE
CATCODE 214-428, Vehicle Operations Parking Shed	4425																	By Exception
CATCODE 214-467, Refueling Vehicle Shop	2141	X	X	X	X	X	X	X	X	X	X	X	X	X	X	X	X	
CATCODE 215-552, Weapons and Release Systems Shop	2151	X	X	X			X			X		X					X	
CATCODE 216-642, Conventional Munitions Shop	2162	X	X	X			X			X		X					X	
CATCODE 217-712, Avionics Shop	2171	X	X	X	X	X	X	X	X	X	X	X	X	X	X	X	X	
CATCODE 217-713, Electronic Countermeasures (ECM) Pod Shop and Storage	2171	X	X	X	X	X	X	X				X	X	X	X	X	X	
CATCODE 218-712, Aircraft Support Shop / Storage	2181	X	X	X	X	X	X	X	X	X	X	X	X	X	X	X	X	
CATCODE 218-868, Regional Precision Measurement Equipment Lab (PMEL)	2171																	See CATCODE in Appendix A.3
CATCODE 219-943, Base Civil Engineer Pavement and Grounds	2191	X	X	X	X	X	X	X	X	X	X	X	X	X	X	X	X	
CATCODE 219-944, Base Civil Engineer Maintenance Shop	2191	X	X	X	X	X	X	X	X	X	X	X	X	X	X	X	X	
CATCODE 219-947, Base Civil Engineer Storage	4422	X	X	X	X	X	X	X	X	X	X	X	X	X	X	X	X	

CATEGORY GROUP 42 - EXPLOSIVES FACILITIES

A.1 STAND-ALONE WEAPON SYSTEM or MISSION																		
CATCODE, Title	FAC Code	A-10 or OA-10 (Fighter)	F-15 or F-16 (Fighter)	F-22 or F-35 (Fighter)	C-17 (Airlift)	C-130 (Airlift)	HC-130/HH-60 (Combat Rescue)	KC-135 (Air Refueling)	KC-46A (Air Refueling)	Remotely Piloted Aircraft (RPA)	MC-12	Combat Readiness Training Center (CRTC)	Distributed Comms Ground Sys (DCGS)	EC-130 (Special Operations)	Advanced Airlift Tactics Trng Center (AATTC)	JOINT STARS	Flying Training Unit (FTU)	Remarks
CATCODE 422-258, Above Ground Multi-Cubicle Magazine Storage	4221	X	X	X								X						
CATCODE 422-264, Storage Igloo	4221	X	X	X								X						
CATEGORY GROUPS 44, 45 – STORAGE FACILITIES: COVERED, OPEN, SPECIAL PURPOSE																		
CATCODE 442-257, Base Hazardous Materials Storage	4423	X	X	X	X	X	X	X	X	X	X	X		X	X	X		
CATCODE 442-258, Cryogenics (LOX / LIN) Storage	4122	X	X	X								X					X	
CATCODE 442-628, Base Supply and Equipment Shed	4422	X	X	X	X	X	X	X	X	X	X	X	X	X	X	X	X	
CATCODE 442-758, Base Supply and Equipment Warehouse	4421	X	X	X	X	X	X	X	X	X	X	X		X	X			
CATCODE 452-252, Base Supply Open Storage	4521	X	X	X	X	X	X	X	X	X	X	X	X	X	X	X	X	
CATCODE 452-255, Base Civil Engineer Open Storage	4521	X	X	X	X	X	X	X	X	X	X	X	X	X	X	X	X	
CATEGORY GROUP 61 - ADMINISTRATIVE FACILITIES																		
CATCODE 610-121, Vehicle Operations Administration	6100	X	X	X	X	X	X	X	X	X	X	X	X	X	X	X	X	
CATCODE 610-122, Base Supply Administration	6100	X	X	X	X	X	X	X	X	X	X	X	X	X	X	X	X	
CATCODE 610-123 Gen Admin Bldg.	6100																	By Exception
CATCODE 610-123, General Administrative Bldg.	6100	X	X	X	X	X	X	X	X	X	X	X	X	X	X	X	X	
CATCODE 610-127, Base Civil Engineer Administration	6100	X	X	X	X	X	X	X	X	X	X		X					

A.1 STAND-ALONE WEAPON SYSTEM or MISSION																		
CATCODE, Title	FAC Code	A-10 or OA-10 (Fighter)	F-15 or F-16 (Fighter)	F-22 or F-35 (Fighter)	C-17 (Airlift)	C-130 (Airlift)	HC-130/HH-60 (Combat Rescue)	KC-135 (Air Refueling)	KC-46A (Air Refueling)	Remotely Piloted Aircraft (RPA)	MC-12	Combat Readiness Training Center (CRTC)	Distributed Comms Ground Sys (DCGS)	EC-130 (Special Operations)	Advanced Airlift Tactics Trng Center (AATTC)	JOINT STARS	Flying Training Unit (FTU)	Remarks
CATCODE 610-129, Weapons Systems Maintenance Management (WSMM)	6100	X	X	X	X	X	X	X	X	X	X	X		X	X	X	X	
CATCODE 610-287, Specified Headquarters	6100																	By Excp, See CATCODE
CATCODE 610-913, Emergency Management (EM)	6100	X	X	X	X	X	X	X	X	X	X	X	X	X	X	X	X	
CATEGORY GROUPS 72, 73 - DINING HALL AND QUARTERS, PERSONNEL SUPPORT																		
CATCODE 722-351, Dining & Training Facility	7220	X	X	X	X	X	X	X	X	X	X	X	X	X	X	X	X	
CATCODE 723-392, Sanitary Latrine	7234																	By Excp, See CATCODE
CATCODE 725-517, Troop Camp (Quarters)	7250											X					X	
CATCODE 730-832, Visitor Control Center	7313	X	X	X	X	X	X	X	X	X	X	X	X	X	X	X	X	
CATCODE 730-837, Security Entry Control Facility	1498		X	X			X	X	X		X	X					X	
CATCODE 730-839, Traffic Gatehouse and Guard Booth	1498	X	X	X	X	X	X	X	X	X	X	X	X	X	X	X	X	
CATEGORY GROUPS 74, 75 - MORALE, WELFARE, AND RECREATION FACILITIES																		
CATCODE 740-155, Credit Union	7347																	By exception
CATCODE 740-389, Exchange Service Outlet	7346																	By exception
CATCODE 740-674, Physical Fitness	7421	X	X	X	X	X	X	X	X	X	X	X	X	X	X	X	X	
CATCODE 750-177, Athletic Field Track	7523																	By exception
CATCODE 750-371, Recreational Pavilion	7531	X	X	X	X	X	X	X	X	X	X	X	X	X	X	X	X	
CATEGORY GROUP 85 AND 89 - ROADS, STREETS, AND UTILITIES																		

A.1 STAND-ALONE WEAPON SYSTEM or MISSION																		
CATCODE, Title	FAC Code	A-10 or OA-10 (Fighter)	F-15 or F-16 (Fighter)	F-22 or F-35 (Fighter)	C-17 (Airlift)	C-130 (Airlift)	HC-130/HH-60 (Combat Rescue)	KC-135 (Air Refueling)	KC-46A (Air Refueling)	Remotely Piloted Aircraft (RPA)	MC-12	Combat Readiness Training Center (CRTC)	Distributed Comms Ground Sys (DCGS)	EC-130 (Special Operations)	Advanced Airlift Tactics Trng Center (AATTC)	JOINT STARS	Flying Training Unit (FTU)	Remarks
CATCODE 852-261, Vehicle Parking Operations	8521	X	X	X	X	X	X	X	X	X	X	X	X	X	X	X	X	
CATCODE 852-262, Non-Organizational Vehicle Parking	8521	X	X	X	X	X	X	X	X	X	X	X	X	X	X	X	X	
CATCODE 852-263, Vehicle Parking (Unsurfaced)	1164																	By exception
CATCODE 852-269, Refueler Vehicle Parking	1164	X	X	X	X	X	X	X	X	X	X		X	X	X	X	X	
CATCODE 852-273, Aircraft Support Equipment Storage Yard	1164	X	X	X	X	X	X	X	X	X	X	X	X	X	X	X	X	
CATCODE 872-245, Boundary Fence	8721	X	X	X	X	X	X	X	X	X	X	X	X	X	X	X	X	
CATCODE 872-247, Security Fence / Vehicle Barriers	8721	X	X	X	X	X	X	X	X	X	X	X	X	X	X	X	X	
CATCODE 890-181, Utility Line Ducts	8999	X	X	X	X	X	X	X	X	X	X	X	X	X	X	X	X	

A.2 - Dependent Weapon System or Mission - High Impact

A.2.1 The missions listed in Table A-2 require host support or co-location with a stand-alone mission to provide common support.

A.2.2 Some of these missions include multiple CATCODEs and/or facilities for each Weapons System / Mission.

A.2.3 An “X” in the matrix means that this CATCODE normally associated with the Weapon System or Mission shown.

A.2.4 In cases where the remarks section shows “By Exception”, this CATCODE is authorized with NGB/A4F approval.

A.2 DEPENDENT WEAPON SYSTEM or MISSION - High Impact															
CATCODE, Title	FAC Code	Combat Communications Squadron (CCS)	Air Control Squadron (ACS) / Control & Reporting Center (CRC)	Engineering Installation Squadron (EIS)	Air Traffic Control (ATC)	Aircraft Range	RED HORSE	Regional Training Site (RTS)	Reg'l Equipment Operators Trng Site (REOTS)	Homeland Air Defense/Command and Control	Aerospace Control Alert (ACA)	Special Operations Weather (WF)	MC-12 Mission	Training and Education Center (TEC)	Remarks
CATEGORY GROUP 11 - AIRFIELD PAVEMENTS															
CATCODE 111-111, Runway	1111				X						X				
CATCODE 111-115, Paved Overrun	1113										X				
CATCODE 112-211, Taxiway	1121										X				
CATCODE 113-321, Apron	1131												X		
CATCODE 116-642, Paved Shoulders	1165										X				
CATCODE 116-661, Arm / Disarm Pad	1131										X				
CATCODE 116-922, Aircraft Arresting System (AAS)	1461										X				
CATEGORY GROUP 12 - PETROLEUM DISPENSING AND OPERATING FACILITIES															
CATCODE 123-335, Vehicle Fueling Station (Base Service Station)	1231	X	X	X	X		X	X	X						
CATCODE 124-134, Operating Storage, Diesel	1241	X	X	X	X		X	X							
CATCODE 124-137, Operating Storage, Motor Gas	1241	X	X	X	X		X	X							
CATEGORY GROUP 13 - COMM, NAV AIDS, AIR TRAFFIC CONTROL, AND AIRFIELD LIGHTING															
CATCODE 131-111, Telecommunications	1311	X	X	X	X		X								
CATCODE 132-133, Equipment Pad	8526		X		X			X		X					
CATCODE 134-341, Mobile Radar Support	1331				X										
CATCODE 134-351, Instrument Landing System (ILS) Glide Slope	1331				X										
CATEGORY GROUP 14 - LAND OPERATIONAL FACILITIES															
CATCODE 141-453, Base Operations	2111										X				

A.2 DEPENDENT WEAPON SYSTEM or MISSION - High Impact															
CATCODE, Title	FAC Code	Combat Communications Squadron (CCS)	Air Control Squadron (ACS) / Control & Reporting Center (CRC)	Engineering Installation Squadron (EIS)	Air Traffic Control (ATC)	Aircraft Range	RED HORSE	Regional Training Site (RTS)	Reg'l Equipment Operators Trng Site (REOTS)	Homeland Air Defense/Command and Control	Aerospace Control Alert (ACA)	Special Operations Weather (WF)	MC-12 Mission	Training and Education Center (TEC)	Remarks
CATCODE 141-454 Special Operations	1444										X				
CATCODE 141-459 Crew Readiness	1412									X					
CATCODE 141-461, Command Post	1441												X		
CATCODE 141-753, Squadron Operations (Sqd Ops)	1412											X			
CATCODE 149-967, Observation Tower	1734					X									
CATEGORY GROUP 17 - TRAINING FACILITIES															
CATCODE 171-443, Reserve Forces General Training Support	1714														By Exception, See CATCODE
CATCODE 171-445, Reserve Forces Operational Training	1714					X	X	X	X	X					
CATCODE 171-447, Reserve Forces Communications & Electronics Training	1711	X	X	X	X					X					
CATCODE 171-450, Reserve Forces Medical Training / Administration	5500	X	X	X	X		X								
CATCODE 171-471, Range Control House (RCH)	1731					X									
CATCODE 171-472, Range Supply and Equipment Storage	1731					X									
CATCODE 171-473, Range Target Storage and Repair	1731					X									
CATCODE 171-476, Combat Arms Training Maintenance (CATM)	1718						X					X			
CATCODE 179-371, Miscellaneous Training	1790							X							
CATCODE 179-481, Aircraft Range	1793					X									
CATCODE 179-511, Fire Fighter Training Facility	1795							X							

A.2 DEPENDENT WEAPON SYSTEM or MISSION - High Impact															
CATCODE, Title	FAC Code	Combat Communications Squadron (CCS)	Air Control Squadron (ACS) / Control & Reporting Center (CRC)	Engineering Installation Squadron (EIS)	Air Traffic Control (ATC)	Aircraft Range	RED HORSE	Regional Training Site (RTS)	Reg'l Equipment Operators Trng Site (REOTS)	Homeland Air Defense/Command and Control	Aerospace Control Alert (ACA)	Special Operations Weather (WF)	MC-12 Mission	Training and Education Center (TEC)	Remarks
CATEGORY GROUP 21 - MAINTENANCE FACILITIES															
CATCODE 214-422, Vehicle Service Rack	2145	X	X	X	X	X	X		X	X		X			
CATCODE 214-425, Vehicle Maintenance Shop	2141	X	X	X	X	X	X		X	X		X			
CATCODE 214-428, Vehicle Operations Parking Shed	4425	X	X	X	X	X	X	X	X	X					
CATCODE 214-467, Refueling Vehicle Shop	2141	X	X	X		X	X								
CATCODE 219-943, Base Civil Engineer Pavement and Grounds	2191						X								
CATCODE 219-944, Base Civil Engineer Maintenance Shop	2191						X								
CATCODE 219-947 Base Civil Engineer Storage	4422	X	X	X	X	X	X			X					
CATEGORY GROUP 42 – EXPLOSIVES FACILITIES															
CATCODE 422-258, Above Ground Multi-Cubicle Magazine Storage	4221					X									
CATEGORY GROUPS 44, 45 – STORAGE FACILITIES: COVERED, OPEN, SPECIAL PURPOSE															
CATCODE 442-257, Base Hazardous Materials Storage	4423	X	X	X	X	X	X			X					
CATCODE 442-628, Base Supply and Equipment Shed	4422	X	X	X	X		X	X	X	X					
CATCODE 442-758, Base Supply and Equipment Warehouse	4421	X	X	X	X		X			X		X			
CATCODE 452-252, Base Supply Open Storage	4521	X	X	X	X		X			X		X			
CATCODE 452-255, Base Civil Engineer Open Storage	4521						X	X							As required at large GSUs
CATEGORY GROUP 61 - ADMINISTRATIVE FACILITIES															
CATCODE 610-121, Vehicle Operations Administration	6100	X	X	X	X										

A.2 DEPENDENT WEAPON SYSTEM or MISSION - High Impact															
CATCODE, Title	FAC Code	Combat Communications Squadron (CCS)	Air Control Squadron (ACS) / Control & Reporting Center (CRC)	Engineering Installation Squadron (EIS)	Air Traffic Control (ATC)	Aircraft Range	RED HORSE	Regional Training Site (RTS)	Reg'l Equipment Operators Trng Site (REOTS)	Homeland Air Defense/Command and Control	Aerospace Control Alert (ACA)	Special Operations Weather (WF)	MC-12 Mission	Training and Education Center (TEC)	Remarks
CATCODE 610-122, Base Supply Administration	6100	X	X	X	X	X	X								
CATCODE 610-913, Emergency Management (EM)	6100						X								
CATEGORY GROUPS 72, 73 - DINING HALL AND QUARTERS, PERSONNEL SUPPORT															
CATCODE 722-351, Dining & Training Facility	7220	X	X	X	X		X			X					
CATCODE 723-392, Sanitary Latrine	7234							X							
CATCODE 725-517, Troop Camp (Quarters)	7250						X	X	X					X	
CATCODE 730-839, Traffic Gatehouse and Guard Booth	1498	X	X	X	X	X	X			X					
CATEGORY GROUPS 74, 75 - MORALE, WELFARE, AND RECREATION FACILITIES															
CATCODE 740-674, Physical Fitness	7421	X	X	X	X	X	X			X		X		X	
CATCODE 750-371, Recreational Pavilion	7531	X	X	X	X	X	X	X	X	X	X	X		X	
CATEGORY GROUP 85 AND 89 - ROADS, STREETS, AND UTILITIES															
CATCODE 852-261, Vehicle Parking Operations	8521	X	X	X	X	X	X	X		X		X			
CATCODE 852-262, Non-Organizational Vehicle Parking	8521	X	X	X	X		X			X		X			
CATCODE 852-263, Vehicle Parking (Unsurfaced)	8522														By Exception
CATCODE 852-269, Refueler Vehicle Parking	1164														By Exception
CATCODE 872-247, Security Fence / Vehicle Barriers	8721	X	X	X	X	X	X								

A.3 - Dependent Weapon System or Mission - Low Impact

A.3.1 The missions listed in Table A-3 require host support or co-location with a stand-alone mission to provide common support.

A.3.2 Some of these missions include single CATCODEs and/or facilities for each Weapons System / Mission.

A.3.3 An “X” in the matrix means that this CATCODE normally associated with the Weapon System or Mission shown.

A.3.4 In cases where the remarks section shows “By Exception”, this CATCODE is authorized with NGB/A4F approval.

CATCODE, Title	FAC Code	Information Operations (NWS, IOS, IOF, IAS)	Distributed Comm Ground Systems (DCGS)	Aeromedical Evacuation (AES)	Component Numbered Air Force (CNAF)	Precision Measuring Equipment Lab (PMEL)	Expeditionary Medical System (EMEDS)	Tactical Air Control Sys (ASOC, ASOG, ASOS)	Small Air Terminal (SAT)	Distributed Training Operations Center (DTOC)	ANG Lightning Force Academy	Special Tactics Squadron (STS)	Combat (Battlefield) Weather	Special Operations Weather Team (SOWT)	Remarks
CATCODE 141-454, Tactical Operations	1444	X	X												
CATCODE 141-783, Small Air Terminal (SAT)	1412								X						
CATCODE 171-212, Simulator Training	1721									X					
CATCODE 171-443, Reserve Forces General Training Support	1714				X						X		X	X	
CATCODE 171-447, Reserve Forces Communications & Electronics Training	1711						X								
CATCODE 442-758, Base Supply and Equipment Warehouse	4421			X		X									
CATCODE 610-122, Base Supply Administration				X		X									

Appendix B: Functional Standards & CATCODE Adjustments

B.1 – Functional Standards

1. The UMD, aircraft, and equipment mission sets match the ANGH 32-1084 CATCODE Functional Standards which are assigned to an installation on the 920. The 920 compares the reported 7115 square footage assigned per CATCODE per building and the 920 is a balance sheet to help find ways to consolidate and divest when possible. Each CATCODE shows maximum square footage as a ceiling thus if a mission is fully functional at a smaller square footage, then there may not be a shortcoming. The 920 is also used to calculate local funds thus only use CATCODEs as described in the ANGH 32-1084 because if you use a CATCODE not on the 920 then you do not earn sustainment local funds.

B.2 – CATCODE Adjustments

1. There are two processes for CATCODE adjustments:
 - a. The Functional Space Standards Management (FSSM) Tool is to adjust an existing CATCODE only if there is a greater than 15% increase over the published ANGH 32-1084 CATCODE Functional Standard. The FSSM is an automated routing process with FAM input, can add detailed data such as UMD changes or equipment changes or mission changes. Complete FSSM routing is through A4FD, A4FR and to A4F for approval or disapproval. Only the A4F makes square footage changes. FSSM: <https://intelshare.intelink.gov/sites/ngba4tools/fssm/Module/Requests.aspx>
 - b. Mission changes are also worked through FAMs or NGB/A5/8 with NGB/A4 that would be communicated to the installation as data is known. Typically, if one CATCODE goes up then another CATCODE at the same installation would probably go down. Need complete data for any changes.

Appendix C: Reference Information

C.1 - General Criteria

This chapter contains a glossary of reference materials that can be used in conjunction with this handbook. The glossary consists of reference publications, abbreviations and acronyms, and terms.

C.2 - Reference Publications

Air Force Publications

- [AFH 10-222 V7](#), *Emergency Airfield Lighting Systems*
- [AFI 10-402, Vol. 1](#), *Mobilization Planning and Personnel Readiness*
- [AFI 10-403](#), *Deployment Planning and Execution*
- [AFI 11-212](#), *Munitions Requirements for Aircrew Training*
- [AFI 11-230](#), *Instrument Procedures*
- [AFI 11-403](#), *Aerospace Physiological Training Program*
- [AFI 13-204](#), *Functional Management of Airfield Operations*
- [AFI 13-212](#), *Range Planning and Operations*
- [AFI 21-112](#), *Aircrew Egress Systems*
- [AFI 21-113](#), *Air Force Metrology and Calibration (AFMETCAL) Management*
- [AFI 21-201](#), *Conventional Munitions Maintenance Management*
- [AFI 23-201](#), *Fuels Management*
- [AFI 23-302](#), *Vehicle Management*
- [AFI 24-301](#), *Vehicle Operations*
- [AFI 25-201](#), *Support Agreements Procedures*
- [AFI 31-101](#), *Integrated Defense (FOUO)*
- [AFI 31-202](#), *Military Working Dog Program*
- [AFI 31-205](#), *The Air Force Corrections System*
- [AFI 32-1012](#), *Reserve Component Facilities Programs*
- [AFI 32-1020](#), *Planning and programming Built Infrastructure*
- [AFI 32-1062](#), *Electric Systems, Power Plants And Generators*
- [AFI 32-1064](#), *Electrical Safe Practice*
- [AFI 32-1065](#), *Grounding Systems*
- [AFI 32-2654](#), *Combat Arms Program* (All Air Force range criteria has been moved to UFC 4-179-02, which replaced Facilities Criteria 4-179-03F and Engineering Technical Letter 11-18. Units may not deviate from minimum design criteria items directed by UFC 4-179-02.)
- [AFI 32-3001](#), *Explosive Ordnance Disposal (EOD) Program*
- [AFI 32-7040](#), *Air Quality Compliance and Resource Management*
- [AFI 32-7041](#), *Water Quality Compliance*
- [AFI 32-7044](#), *Storage Tank Compliance*
- [AFI 32-7045](#), *Environmental Compliance Assessment and Management Program*
- [AFI 32-7061](#), *The Environmental Impact Analysis Process*

[AFI 32-7062](#), *Air Force Comprehensive Planning*
[AFI 32-7063](#), *Air Installation Compatible Use Zone Program*
[AFI 32-9002](#), *Use of Real Property Facilities*
[AFI 32-9010](#), *Management and Reporting of Air Force Space and Building Services in OSD assigned Facilities and in the Washington DC Area*
[AFI 33-104](#), *Base-Level Planning and Implementation*
[AFJMAN 32-1082](#), *Facilities Engineering Electrical Exterior Facilities*
[AFJMAN 32-1083](#), *Facilities Engineering Electrical Interior Facilities*
[AFMAN 48-155](#), *Occupational and Environmental Health Exposure Controls*
[DESR 6055.09 AFMAN 91-201](#), *Explosives Safety Standard*
[AFMAN 32-1040](#), *Civil Engineer Airfield Infrastructure Systems* (Replaces: AFI 32-1042, *Standards for Marking Airfields*; AFI 32-1043, *Managing, Operating, and Maintaining Aircraft Arresting Systems*; and AFI 32-1044, *Visual Air Navigation Systems*)
[AFMAN 32-1084](#), *Facility Requirements (Air Force) is re-designated Department of the Air Force Manual (DAFMAN) 32-1084*
[AFLC/DEP](#), *Hush House Site Planning Bulletin*
[AFOSH STD 91-20](#), *Vehicle Maintenance Shops*
[AFPAM 32-1010](#), *Land Use Planning*
[AFPD 32-10](#), *Installations & Facilities*
[AFRCH 32-1001](#), *Standard Facility Requirements (Air Force Reserve Command)*
[Air Force Fire Station Design Guide](#)
[Air Force Services Facilities Design Guide, Design: Fitness Centers](#)
[ANSI Z358.1-2014](#), *American National Standard for Emergency Eyewash and Shower Equipment*
[DAFMAN 32-1084](#), *Department of the Air Force Manual (DAFMAN) 32-1084*
[ETL 06-11](#), *Utilities Reporting for Air Force Facilities*
[ETL 04-7](#), *C-130 and C-17 Landing Zone(s) Dimensional, Marking, and Lighting Criteria*

Air National Guard Publications

[ANGI 32-1003](#), *Facilities Board (FB)*
[ANGI 32-1023](#), *Criteria & Standards for ANG Construction*

Department of Defense Documents

[DoDI 2000.16](#), *DoD Antiterrorism (AT) Standards*
[DoD Directive 6055.09E](#), *Explosives Safety Management (ESM)*

Unified Facilities Criteria Documents

Whole Building Design Guide: www.wbdg.org

[UFC 1-200-01](#), *General Building Requirements*

[UFC 3-201-02](#), *Landscape Architecture*

[UFC 3-210-02](#), *POV Site Circulation and Parking*

[UFC 3-210-10](#), *Low Impact Development*

[UFC 3-230-08A](#), *Water Supply: Water Treatment*

[UFC 3-230-09A](#), *Water Supply: Water Storage*

[UFC 3-230-10A](#), *Water Supply: Water Distribution*

[UFC 3-240-02N](#), *Wastewater Treatment System Augmenting Handbook*

[UFC 3-250-01FA](#), *Pavement Design for Roads, Streets, Walks, and Open Storage Areas*

[UFC 3-260-01](#), *Airfield and Heliport Planning and Design*

[UFC 3-260-02](#), *Pavement Design for Airfields*

[UFC 3-340-01](#), *Design and Analysis of Hardened Structures to Conventional Weapons Effects*

[UFC 3-410-01FA](#), *Heating, Ventilating, and Air Conditioning, with Change 4*

[UFC 3-430-09](#), *Exterior Mechanical Utility Distribution, with Change 1*

[UFC 3-460-01](#), *Petroleum Fuel Facilities*

[UFC 3-460-03](#), *Operation and Maintenance: Maintenance of Petroleum Systems*

[UFC 3-520-01](#), *Interior Electrical Systems*

[UFC 3-535-01](#), *Visual Air Navigation Systems*

[UFC 3-550-01](#), *Exterior Electrical Power Distribution*

[UFC 3-580-01](#), *Telecommunications Building Cabling Systems Planning and Design*

[UFC 3-600-01](#), *Fire Protection Engineering for Facilities*

[UFC 3-701-09](#), *DoD Facilities Pricing Guide*

[UFC 4-010-01](#), *DoD Minimum Antiterrorism Standards for Buildings*

[UFC 4-010-02](#), *DoD Minimum Antiterrorism Standoff Distances for Buildings*

[UFC 4-020-01](#), *DoD Security Engineering Facilities Planning Manual*

[UFC 4-024-01](#), *Security Engineering: Procedures for Designing Airborne Chemical, Biological, and Radiological Protection for Buildings*

[UFC 4-030-01](#), *Sustainable Development*

[UFC 4-141-04](#), *Emergency Operations Center Planning and Design*

[UFC 4-151-10](#), *General Criteria for Waterfront Construction*

[UFC 4-152-01](#), *Design: Piers and Wharves*

[UFC 4-159-03](#), *Design: Moorings*

- [UFC 4-179-02, Small Arms Range](#)
- [UFC 4-510-01, Design: Medical Military Facilities](#)
- [UFC 4-610-01, Administration Facilities](#)
- [UFC 4-730-10, Fire Stations](#)
- [UFC 4-740-02, Fitness Centers](#)
- [UFC 4-750-02N, Design: Outdoor Sports and Recreational Facilities](#)
- [UFC 4-832-01N, Design: Industrial and Oily Wastewater Control](#)

Federal Aviation Administration Documents

- [FAA \(AC\) 150/5220-9A, Aircraft Arresting Systems for Joint Civil/Military Airports](#)
- [FAA \(AC\) 150/5300-13A, Airport Design](#)

Military Surface Deployment and Distribution Command Transportation Engineering Agency (SDDCTEA)

- [SDDCTEA Pamphlet 55-17, Better Military Traffic Engineering, **ANG will use ANG ECF Template which is based on the AF Low Volume and SDDCTEA Exhibit 1.20: Low Volume ECF with POV Processing Only and will provide 9 seconds form ID Check to Pop-up Barrier**](#)

C.3 – List of Figures

Figure 1-1: Typical Cubicle and Hoteling, the 64 SF and 24 SF, including circulation.....1-7

Figure 1-2: Typical Operations Floor, 42 SF includes circulation and NIPR/SIPR separation needs.....1-7

Figure 1-3: Typical Assembly Space and Conference Room Space1-8

Figure 2-1: CATCODE 116-642, Class B Runway & Taxiway Shoulder Example2-8

Figure 4-1: G-ASNT Transportable Layouts collocated or standalone4-7

Figure 4-2: D-ILS equipment Pad4-12

Figure 5-1: Fighter Alert Crew Quarters, ACC/ASA Guide5-27

Figure 5-2: Use CATCODE 145-921, Overhead Protection, only when not connected to the Gatehouse.5-77

Figure 6-1: CATCODE 171-475, Indoor Small Arms Range 7 Lane Template6-62

Figure 6-2: CATCODE 171-475, Indoor Small Arms Range elevated control booth and firing line6-63

Figure 6-3: CATCODE 171-475, Indoor Small Arms Range showing ventilation control panel in control booth6-63

Figure 6-4: CATCODE 171-476, CATM Template.....6-64

Figure 6-5: CATCODE 171-618, Field Training Facility, Battlefield Airmen Gym, ASOS6-67

Figure 6-6: CATCODE 179-475, Small Arms Range, Outdoor.....6-70

Figure 7-1: WBDG (Link) to published ANG Mission Grouped Hangar Sizes7-1

Figure 7-2: Typical Mx Hangar Bathroom.....7-2

Figure 7-3: Six Mission Grouped Fighter with Single Door Hangar Bay Size7-2

Figure 7-4: Airlift/Tanker Large Mx Hangar Bay proof of concept and an existing project.....7-3

Figure 7-5: CATCODE 211-175, Medium Mx Hangar Bay Layouts7-4

Figure 7-6: C-130 and C-130J-30 Stretched Maintenance Hangar Size.....7-5

Figure 7-7: CRTM Maintenance Hangar7-5

APPENDIX C: REFERENCE INFORMATION

Figure 7-8: MQ-1 and MQ-9, UAV Maintenance Final Design Guide.....7-6

Figure 7-9: CATCODE 211-157, F-35 Jet Engine Storage example7-16

Figure 7-10: CATCODE 211-161, Corrosion Control Utility Storage.....7-19

Figure 7-11: CATCODE 211-179, Fighter Fuel System Mx Dock with Shops7-20

Figure 7-12: F15-EX Drop Tank layout for 18 or 21PAA, each tank on cradles7-20

Figure 7-13: CATCODE 214-422 per 2016 AF Category Code book7-22

Figure 7-14: Proof of concept for Typical Vehicle Maintenance Admin, Shops, & Refueler.....7-24

Figure 7-15: Example square footage for angled parking vs straight parking7-25

Figure 7-16: CATCODE 216-642, Example Layout Admin, inert storage, and trailer Mx7-30

Figure 7-17: CATCODE 216-642, Example Layout M&I and Inspections7-31

Figure 7-18: CATCODE 216-642, Example Munitions Site Plan showing M&I separation to Inspections.
The separation distance is always based on DDESB approved explosive site plans.7-31

Figure 7-19: CATCODE 217-713, ECM Pod Shop/Storage Layouts7-36

Figure 7-20: CATCODE 219-947, BCE Storage Shed example images.....7-45

Figure 9-1: CATCODE 422-264, Storage Igloo example, used for F-15EX9-2

Figure 12-1: CATCODE 730-839, Main Gate Gatehouse detailed layout, in use since 2004.....12-13

Figure 12-2: Guard Booth size based on Army Corps standard and Andrews Guard Booth12-14

Figure 12-3: Air Force use of ID Check 6” from edge of curb12-14

Figure 12-4: CATCODE 730-839, Guard Booth layout and elevation details, when used12-14

Figure 12-5: SDDCTEA Exhibit 1.20: Low Volume ECF with POV Processing and AF Low Volume, for
reference12-15

Figure 12-6: NGB/A4 SharePoint Find 9 Tool intro and launch page from above link12-15

Figure 12-7: ANG ECF Template Detailed View separated vehicle inspection12-16

Figure 12-8: ANG ECF Template Detailed View collocated commercial vehicle inspection12-17

Figure 12-9: ANG ECF Template two lanes in with separated commercial inspection, use only if a secondary
gate is available and can handle oversized vehicles.....12-18

Figure 12-10: ANG ECF Template collocated commercial vehicle inspection, use only if a secondary gate is
available and can handle oversized vehicles12-19

Figure 12-11: ANG ECF Template complete layout, use of curves to meet the 9 seconds.....12-20

Figure 13-1: CATCODE 750-177, Running Track Layout.....13-4

Figure 13-2: CATCODE 750-177, Running Track Lane Line Details.....13-4

Figure 14-1: CATCODE 852-269, example parking lot for refueling trucks.....14-3

Figure 15-1: Screen of NGB/A4FR SharePoint to find Religious Service Memo38

C.4 - Abbreviations and Acronyms

AAS - Aircraft Arresting System

AATC - Air National Guard Air Force Reserve Command Test Center

A/C – Aircraft

ACA – Aerospace Control Alert

ACA– Advisory Circular

ACBRN – Aircrew Chemical Biological Radiological Nuclear

ACMI – Air Combat Maneuvering & Instrumentation

APPENDIX C: REFERENCE INFORMATION

ACS - Air Control Squadron
ACTS - Aircrew Combat Training System
ADA – Americans with Disabilities Act
Admin - Administrative
ADPE - Automated Data Processing Equipment
AE - Aeromedical Evacuation
AF - Air Force
AFCEC - Air Force Civil Engineer Center
AFE - Aircrew Flight Equipment
AFFF – Aqueous Film Forming Foam
AFH - Air Force Handbook
AFI - Air Force Instruction
AFISRA - Air Force Intelligence, Surveillance and Reconnaissance Agency
AFMAN - Air Force Manual
AFMC - LSO/LOE – Air Force Material Command - Logistics Support Office/Logistics Engineering
AFOSH - Air Force Occupational Safety and Health
AGE - Aerospace Ground Equipment
AGS - Aircraft Generation Squadron
AKA - Also known as
ALS/ULS - Ammunition Loading System/Universal Loading System
AME - Alternate Mission Equipment
AMU - Aircraft Maintenance Unit
AMXS - Aircraft Maintenance Squadron
ANG - Air National Guard
ANGRC - Air National Guard Readiness Center
ANGETL - Air National Guard Engineering Technical Letter
ANGH - Air National Guard Handbook
ANGI - Air National Guard Instruction
ARNG - Army National Guard
AOC - Air Operations Center
APF - Aerial Port Flight
APG - Airplane General
API – American Petroleum Institute

APPENDIX C: REFERENCE INFORMATION

APS - Aerial Port Squadron
APU - Auxiliary Power Unit
ARC - Air Reserve Component, Advanced Rescue Craft
ARD - Armament Recording Device
ASA - Air Sovereignty Alert
ASE - Air Support Equipment
ASM - Aircraft Structural Maintenance
ASOC - Air Support Operations Center
ASOS - Air Support Operations Squadron
ATC - Air Traffic Control
ATCS - Air Traffic Control Squadron
AT/FP - Antiterrorism Force Protection
ATSO - Ability To Survive & Operate
Auth - Authorized
BAI - Backup Aircraft Inventory
BCE - Base Civil Engineer
BCTF - Base Central Test Facility
BDOC - Base Defense Operations Center
BDU - Bomb, Dummy Unit
BEE - Biological Environmental Engineering
BL - Barrel(s) (Measurement)
BLOS - Beyond Line of Sight
BLSS - Base Level Self-Sufficiency Spares
BNCC - Base Network Control Center
BOS - Base Operating Support
BOT - Boom Operator Trainer
BRITE - Bright Radar Indicator Tower Equipment
BSERV - Bomb Squad Emergency Response Vehicle
CA - Combat Arms
CAMS - Core Automated Maintenance System
CAS B - Combat Ammunition System - Base
Cat - Category
CAT - Commanders Action Team
CATCO - Chief Air Traffic Control Officer

APPENDIX C: REFERENCE INFORMATION

CATM - Combat Arms Training & Maintenance
CATS - Combat Arms Training Simulator
CBRN - Chemical, Biological, Radiological, and Nuclear
CBRNE - Chemical, Biological, Radiological, Nuclear, and high yield Explosives
C-CBRN - Counter Chemical, Biological, Radiological, and Nuclear
CBT - Computer Based Training
CCG - Combat Communications Group
CCI - Controlled Crypto Item
CCP - Compass Calibration Pad
CCS - Combat Communications Squadron
CCT - Combat Control Team
CCTV - Closed-Circuit Television
CDCS - Containerized Dual Control Station
CDF - Cargo Deployment Function
CDK - Containerized Deployment Kitchen
CE - Civil Engineering
CERFP - Chemical, Radiological/Nuclear & Explosive – Enhanced Response Force Package
CFT - Cockpit Familiarization Trainer
CFP - Communications Focal Point
COCOM - Combatant Commander
Comm - Communications
COMSEC - Communications Security
CONUS - Continental United States
COS - Combat Operations Support
CPC - Command Post Controller
CRO - Combat Rescue Officer
CRRC - Combat Rubber Raiding Craft
CRTC - Combat Readiness Training Center
Crypto - Cryptography
CSC - Central Security Control
CT - Continuation Training
CTK - Composite Tool Kit
CWA - Clean Water Act
DCC - Damage Control Center

APPENDIX C: REFERENCE INFORMATION

DCC - Deployment Control Center
DDESB - Department of Defense Explosive Safety Board
DESC - Defense Energy Support Center
DGS - Distributed Ground Station
Distr – Distributionq
DMT - Distributed Mission Training
DoD - Department of Defense
DPC - Deployment Processing Center
DPU - Deployment Processing Unit
DRMO - Defense Reutilization/Marketing Office
DSCA - Defense Support of Civil Authorities
ECC – Emergency Communications Center
ECF - Entry Control Facility
ECM - Electronic Countermeasure
ECM - Earth Covered Magazines (ECM) also known as “igloos”
EET - Exercise Evaluation Team
EH - Environmental Health
EIS - Engineering Installation Squadron
EKG - Electrocardiogram
Elec - Electrical
EMCS - Energy Management Control System
EMEDS-CM - Expeditionary Medical Support – Consequence Management
EOC - Emergency Operations Center
EOD - Explosive Ordnance Disposal
EPT - Egress Procedures Trainer
EST - Engagement Skills Trainer
ETL - Engineering Technical Letter
F - Female
F/T - Full Time
FAA - Federal Aviation Administration
FAX - Facsimile
FOC - Full Operational Capability
FOD - foreign object damage
FSRT - Fatality Search and Recovery Team

APPENDIX C: REFERENCE INFORMATION

FT (ft.) - Foot (Feet) (Measurement)
FTU - Formal Training Unit
FuT - Fuselage Trainer
GCA - ground controlled approach
GCS - Ground Control Station
GDT - Ground Data Terminal/Transmitter
GFE - Government-Furnished Equipment
GL - Gallon(s) (Measurement)
GOV - Government-Owned Vehicle
GPM - Gallons per Minute (Measurement)
GSF - Gross Square Feet
GSU - Geographically Separated Unit
HARM - High-Speed Anti-Radiation Missile
HAZMAT - Hazardous Material
HC/D - Hazard Class/Division
HMMWV - High-Mobility Multi-Purpose Wheeled Vehicle
HQ - Headquarters
HQ AFMC/CEPR - Headquarters Air Force Material Command/Civil Engineering Programs/Real Property
HRF - Homeland Response Force
HRO - Human Resource Office
HST - Home Station Training
HVAC - Heating, Ventilation, and Air Conditioning
IBDCZ - Inhabited Building Distance Clear Zone
ICAP - Integrated Communications Access Package
ICC or IC2 - Installation Command and Control
ID - Identification
IDMT - Independent Duty Medical Technician
IFF - Identification, Friend or Foe
IG - Inspector General
IM - Information Management
IN - inch(es) (Measurement)
Intel - Intelligence
IOC - Initial Operational Capability

APPENDIX C: REFERENCE INFORMATION

IRSP - In-Place Readiness Spares Packages
ISR - Intelligence, Surveillance, and Reconnaissance
ISSA - Inter/Intra Service Support Agreement
ITN - Information Transfer Node
IWAS - Information Warfare Aggressor Squadron
JAG - Judge Advocate General
JCA - Joint Cargo Aircraft
JFHQ - Joint Force Headquarters
JOAP - Joint Oil-Analysis Program
JWICS - Joint Worldwide Intelligence Communication System
Lab - Laboratory
LAN - Local Area Network
LANA - Low Altitude Night Attack
LANTIRN - Low Altitude Night Terrain Infrared Navigation
LB - pound(s) (Measurement)
LFA - Lightning Force Academy
LGX - Logistics Readiness/Plans
LIN - Liquid Nitrogen
LMR - Land Mobile Radio
Log – Logistics
LOASM - Low Observable Aircraft Structural Maintenance
LOX - Liquid Oxygen
LRE - Launch and Recovery Element
LRGCS - Launch and Recovery Ground Control Station
LSC - Loading Standardization Certification
MAFFS - Modular Airborne Fire-Fighting System
MAs - Military Authorizations
Maint - Maintenance
MAJCOM - Major Command
Max - Maximum
MCE - Mission Control Element
Mech - Mechanical
METNAV - Meteorological Navigational
Mgmt - Management

APPENDIX C: REFERENCE INFORMATION

MI - mile(s), statute (Measurement)
Min - Minimum
Misc - Miscellaneous
MKT - Mobile Kitchen Trailer
MM - Mission Monitor
MMLS - Mobile Microwave Landing System
MOC - Maintenance Operations Control
MOGAS - Motor Gas (Automotive Gasoline)
MRSP - Mobility Readiness Spares Package
MRTS - Medical Readiness Training Site
MWR - Morale, Welfare, and Recreation
NAF - Non-Appropriated Funds
NCOIC - Noncommissioned Officer In Charge
NDI - Non-Destructive Inspection
NGB - National Guard Bureau
NIPR - Nonsecure Internet Protocol Routing
NIPRNet - Nonsecure Internet Protocol Routing Network
O - Officer
O&T - Operations and Training
OCONUS - Outside Continental United States
OIC - Officer In Charge
OL - Outlets
OPR - Office of Primary Responsibility
Ops - Operations
OSHA - Occupational, Safety and Health Administration
PAA - primary aircraft authorization
Par - Paragraph
PAX - Passenger
PDF - Personnel Deployment Function
PERSCO - Personnel Support for Contingency Operations
Pers - Personnel
PJ - Para-jumper (Pararescue personnel)
PMEC - Professional Military Education Center
PMEL - Procession Measurement Equipment Laboratory

APPENDIX C: REFERENCE INFORMATION

PMI - Preventive Maintenance Inspection
POC - Predator Operations Center, Point Of Contact
POL - Petroleum, Oil, and Lubricants
PPE - Personal Protective Equipment
PPIF - Photo Processing and Interpretation Facility
PPSL - Predator Primary Satellite Link
Prime BEEF - Priority Improved Management Effort – Base Engineer Emergency Force
Prime RIBS - Priority Improved Management Effort – Readiness In Base Services
QA - Quality Assurance
QD - Quantity Distance
RAPCON - Radar Approach Control
RBS - Rigid Inflatable Boat System
RC - Reconnaissance
RCH - Range Control House
RECCE - Reconnaissance
RED HORSE - Rapid Engineers Deployable Heavy Operations Repair Squadron, Engineers
REOTS - Regional Equipment Operators Training Site
RHA - Residue Holding Area
RIBS - Rigid Inflatable Boat System
ROSC - Regional Operations Support Center
RPA - Remote Piloted Aircraft
RQW - Rescue Wing
RSO - Remote Split Operations
RSP - Reserve Spare Parts
RTS - Regional Training Site
Sat - Satellite
SATO - Scheduled Airline Travel Office
SCBA - Self-Contained Breathing Apparatus
SCC - Security Control Center
SCIF - Sensitive Compartmented Information Facility
SCUBA - Self-Contained Underwater Breathing Apparatus
SERE - Survival, Evasion, Resistance and Escape
SF - square foot (feet) (Measurement)
Sgt - Sergeant

APPENDIX C: REFERENCE INFORMATION

SIF - Selective Identification Feature
SIPERNET - Secure Internet Protocol Ethernet Router Network
SIPR - Secure Internet Protocol Routing
SIPRNet - Secure Internet Protocol Routing Network
SO - Sensor Operator
SOF - Supervisor of Flying
SOI - Statement of Intent
SOWT - Special Operations Weather Team
SPEK - Single Pallet Expeditionary Kitchen
Squad - Squadron
SRC - Survival Recovery Center
Stan / Eval - Standardization & Evaluation
Std (s) - Standard (s)
STEM - Systems Telecommunications Engineering Manager
Stge - Storage
STO- Special Tactics Officer
STOC - Special Tactics Operations Center
STS - Special Tactics Squadron
SY - square yard(s) (Measurement)
T-SCIF - Tactical - Sensitive Compartmented Information Facility
TAC - Terminal Attack Controller
TACAN - Tactical Air Navigation
TALCE - Tanker/Airlift Control Element
TARS - Tactical Air Reconnaissance System
TCU - Transportation Control Unit
TCV - Total Containment Vessel, EOD
TDC - Theater Deployable Communications
TDY - Temporary Duty
TEC - Training and Education Center
TERPS - Terminal Instrument Procedures
TMDE - Test, Measurement, and Diagnostic Equipment
TMO - Traffic Management Office
T.O. - Technical Order
Trng - Training

APPENDIX C: REFERENCE INFORMATION

Tri-Tac - Tri-Service Tactical
TSEC - Tactical Support Element Communications
UAS - Unmanned Aerial System
UAV - Unmanned Aerial Vehicle
UDCC/CFP - Unit Deployment Control Center/Communications Focal Point
UE - Unit Equipped
UFC - Unified Facilities Criteria
UPS - Uninterruptible Power Supply
US - United States
UTA - Unit Training Assembly
UTC - Unit Type Code
UTM - Unit Training Manager
VE - Vehicle Equivalent
VHF - Very High Frequency
VOR - VHF Omni-Directional Range
VORTAC - Collocated VOR and TACAN facility
VTC - Video Teleconference
WFHQ - Warfighting Headquarters
WOC - Wing Operations Center
WRM - War Reserve Material
WRSK - War Readiness Spares Kit
WSMM - Weapons Systems Maintenance Management
WST - Weapon Skills Trainer
WST - Weapons System Trainer (typically aircraft Full Motion Simulator)

C.5 - Terms

Administrative Space - Wherever possible, administrative (admin) space should consist of open, pre-wired work stations, with only the minimum (min.) essential number of enclosed offices constructed. Open office design and use of systems furniture will be considered. Interior construction should provide flexibility for future interior renovations. Private offices are only authorized in accordance with ANGH 32-1084, Chapter 1, Section 1.7. If additional offices are required they must be justified in the Project Book.

Administrative Support Space - Includes area(s) adequate to house any computer equipment, filing systems, copy/reproduction machinery, telephone and Local Area Network (LAN) systems and publication libraries related to the function.

Break areas - Break areas are for facilities, not organizations. Break areas include vending area, refrigerator, cabinets and sink. A separate seating area is not provided. Seating shall be provided

adjacent classrooms or conference / meeting space. Classrooms should be dividable and located near break areas for convenience.

Covered Storage - Covered storage generally consists of a shed with three walls. In [Northern Tier Locations](#) or other locations subject to freezing conditions, it also includes enclosed space with minimal heat to prevent freezing.

Gross Area - The gross area includes the total area of all floors, including mezzanines, basements, penthouses, and other enclosed spaces as measured from the exterior faces of the exterior walls. Enclosed stairwells, elevators, utility chases, and mechanical rooms are included as part of the area of each floor that they occupy. Only the floor area of the lowest level of the atrium is included in the gross total. See Section [1.9 Scope Calculations](#)

Net Square Feet - Net Square Feet (NSF) is the area of an individual room or area that is assigned to a function in an open area. Net square feet for each room with circulation is measured from the inside finished surface of surrounding partitions or enclosing elements. NSF does not include overhead such as building hallways and mechanical rooms.

Infrastructure – A framework of interdependent assets, networks, and systems comprising identifiable industries, institutions, and distribution capabilities that provide a continual flow of goods and services essential to the defense and economic security of the United States, the smooth functioning of government at all levels, or society as a whole.

Mezzanine - An intermediate story in a facility and is full scope space regardless of height even if an equipment item. The UFC 3-101-01 mezzanine definition does not apply to the ANG.

Programming – Consists of the research and decision-making process that identifies the scope of work to be designed / constructed. The programming of space for renovation or a new facility uses the Functional Standards in this Handbook and specific guidance from applicable OPRs, where necessary.

Religious Service and Activities – To support these religious services, ANG Installations utilize conference and meeting spaces in various facilities for observation of religious services and activities, including facilities coded for Reserve Forces General Training Support, Reserve Forces Operational Training, Dining and Training, and available conference, briefing, and multi-purpose training areas. ANGH 32-1084, Facility Space Standards, does not authorize Chapel facilities nor reserve functional space for Chapels or related religious activities in the ANG. See signed “ANG Facility Guidance for Religious Services and Activities - 31 May 12.pdf” at: <https://intelshare.intelink.gov/sites/ngba4/SitePages/ProgramA4F.aspx?Program=60&InitialTabId=Ribbon%2ERead&VisibilityContext=WSSTabPersistence>

Which is A4FR - Requirements ANGH 32-1084, Documents, General Information, Policy

Figure 15-1: Screen of NGB/A4FR SharePoint to find Religious Service Memo

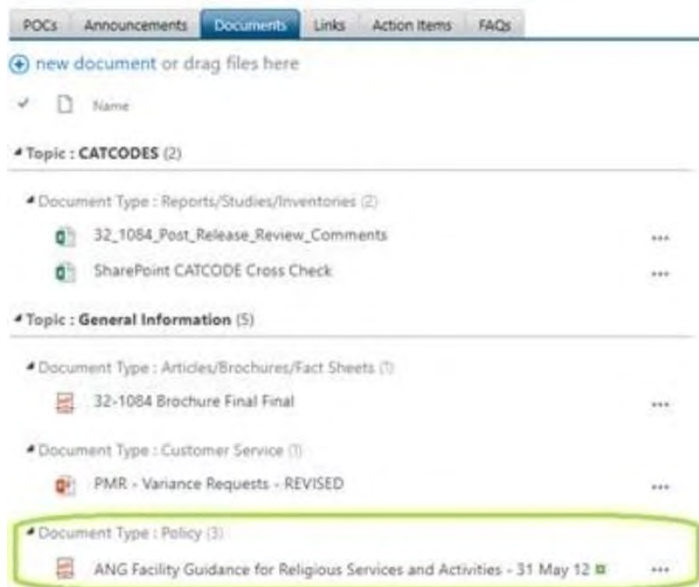

Service Support Space - Includes janitor / comm closets, mech / elec rooms, and loading docks/receiving areas.

Shaped Hangar - An aircraft hangar bay that follows the swept-wing aircraft "shape" of the xx-130, KC-135, C-17, and KC-46.

Shed – A simple, single story structure used to house equipment from the weather. A shed may have up to four sides and limited heat depending on the location and the equipment being stored. Any shed facility will use the least scope required to meet the function, i.e. if protection from precipitation and sun is all that is required, then no more than three sides will be used.

Special-Use Space - Includes training rooms, classrooms, planning / exercise rooms, conference rooms, auditoriums, locker rooms, area(s) for vending and physical training, and any other space that may be appropriate for the function.

Storage - Facilities will include adequate space for the storage of equipment in the proper locations (home station, mobilization station, central storage, etc.)

Training Rooms / Classrooms / Planning and Exercise Rooms / Auditoriums - Training Rooms and / or classrooms should be sub-dividable into smaller areas. Chairs, tables, podiums, etc. should not be affixed to the floor except in auditoriums.

Weather Extremes - For purposes of these criteria, severe winters are those with 30 or more days per year of 10 degrees Fahrenheit or lower, or with an average January temperature of 20 degrees Fahrenheit or lower (as determined from two 10-year weather data); heavy snowfall is more than 24 inches / 610 millimeters annually; see [Northern Tier Locations](#). Extreme heat means an average daily maximum temperature above 88 degrees Fahrenheit / 31 degrees Celsius for 30 or more days per year.

Appendix D: USAF comparison to ANG CATCODE Tables

D.1 - General Criteria

This chapter will contain the complete and current AF CATCODE list in a side by side comparison to what is used in the ANG. The goal will be to increase the understanding that using the equal ANG CATCODE helps in record keeping and facility management.

