



AIR FORCE HANDBOOK 10-222, VOLUME 2
6 February 2012

BARE BASE ASSETS



DEPARTMENT OF THE AIR FORCE

**BY ORDER OF THE
SECRETARY OF THE AIR FORCE**

**AIR FORCE HANDBOOK 10-222
VOLUME 2**



6 February 2012

Operations

BARE BASE ASSETS

ACCESSIBILITY: Publications and forms are available on the e-Publishing website at www.e-publishing.af.mil for downloading or ordering.

RELEASABILITY: There are no releasability restrictions on this publication.

OPR: AFCESA/CEXX
Supersedes AFH 10-222V2,
1 April 2006

Certified by: AF/A7CX
(Colonel Darren P. Gibbs)
Pages: 128

This handbook describes Basic Expeditionary Airfield Resources (BEAR) Air Force civil engineers are likely to site, install, or operate in an expeditionary field environment. It provides a brief overview of major systems and equipment, along with applicable technical references. Users must refer to specific equipment technical orders for siting, installation, operation and maintenance information. This publication applies to all Air Force active duty, Air National Guard (ANG), and Air Force Reserve Command (AFRC) Civil Engineer units. It supports Air Force Instruction (AFI) 10-209, *RED HORSE Program*; AFI 10-210, *Prime Base Engineer Emergency Force (BEEF) Program* and AFI 10-211, *Civil Engineer Contingency Response Planning*. Refer recommended changes and questions about this publication to the office of primary responsibility using the AF Form 847, *Recommendation for Change of Publication*: route AF Form 847s from the field through the appropriate functional chain of command and Major Command (MAJCOM) publications/forms managers. Ensure that all records created as a result of processes prescribed in this publication are maintained according to AFMAN 33-363, *Management of Records*, and disposed of in accordance with the Air Force Records Disposition Schedule (RDS) located at <https://www.my.af.mil/afirms/afirms/afirms/rims.cfm>. The use of the name or mark of any specific manufacturer, commercial product,

commodity, or service in this publication does not imply endorsement by the Air Force.

SUMMARY OF CHANGES

This document is substantially revised and must be completely reviewed. This revision deletes outdated information and updates changes to Basic Expeditionary Airfield Resources (BEAR), including the addition of the BEAR Water System, 130K Portable Heater, Interim Power Unit (IPU), and the MEP-805B and MEP-806B Tactical Quiet Generators. Also, as a result of ongoing changes to BEAR equipment configurations, new BEAR Order of Battle (BOB) Unit Type Codes (UTC) were added, and users are encouraged to seek current information from the UTC Management or Manpower and Equipment Force Packaging (MEFPAK) Community of Practice (CoP) or see their Unit Deployment Manager (UDM).

Chapter 1—INTRODUCTION	11
1.1. General Information.....	11
1.2. Overview.....	11
Figure 1.1. Air Force Civil Engineer Publications Hierarchy	12
1.3. Roles and Responsibilities	13
Table 1.1. BEAR Roles and Responsibilities	13
1.4. BEAR Accountability.....	15
Figure 1.2. Logistics Personnel Help Keep Track of BEAR Assets.....	16
1.5. Equipment Packaging and Configurations.....	17
Figure 1.3. BEAR Reconfiguration	17
Table 1.2. BOB Air and Surface Equipment UTCs.....	18
1.6. Equipment Repairs.....	20
1.7. Additional Information	20

Chapter 2—SHELTERS	20
2.1. General Information.....	21
Figure 2.1. Erecting Shelters at Forward Operating Location	21
2.2. BEAR Shelters.....	21
Figure 2.2. Small Shelter System	22
Table 2.1. SSS Environmental Limitations	22
Figure 2.3. Medium Shelter System	23
Table 2.2. MSS Environmental Limitations.....	23
Figure 2.4. Bare Base Dome Shelter	24
Table 2.3. Dome Shelter Environmental Limitations.....	24
Figure 2.5. Large Area Maintenance Shelter.....	25
Table 2.4. LAMS Environmental Limitations.....	25
2.3. Legacy Shelters.....	26
Figure 2.6. Frame-Supported Tensioned Fabric Shelter.....	26
Table 2.5. FSTFS Environmental Limitations.....	26
Figure 2.7. General Purpose Shelter.....	27
Table 2.6. GP Shelter Environmental Limitations	27
Figure 2.8. Expandable Shelter Container	28
Table 2.7. ESC Environmental Limitations.....	28
Figure 2.9. Aircraft Maintenance Hangar.....	29
Table 2.8. ACH Environmental Limitations	29
Figure 2.10. Tent Extendable Modular Personnel	30
Table 2.9. TEMPER Environmental Limitations	30

Chapter 3—WATER AND SANITATION	31
3.1. General Information.....	31
3.2. BEAR Water System	31
Figure 3.1. 1500 ROWPU	32
Table 3.1. 1500 ROWPU Particulars	32
Figure 3.2. 20,000-Gallon Fabric Water Tank.....	33
Table 3.2. 20,000-Gallon Tank Characteristics and Information	33
Figure 3.3. 3,000-Gallon Fabric Water Tank.....	34
Table 3.3. 3,000-Gallon Tank Characteristics and Information	34
Figure 3.4. 400-GPM Diesel Pump Assembly	35
Table 3.4. 400-GPM Diesel Pump Characteristics.....	35
Figure 3.5. 35-GPM Electric Pump Assembly	36
Table 3.5. 35-GPM Electric Pump Assembly Characteristics.....	36
Figure 3.6. 125-GPM Diesel Pump Assembly	37
Table 3.6. 125-GPM Diesel Pump Characteristics.....	37
Figure 3.7. Dual Pump Station	38
Table 3.7. Dual Pump Station Characteristics.....	38
Figure 3.8. Bladder Water Level Controller.....	39
Table 3.8. Bladder Water Level Controller Characteristics	39
Figure 3.9. Sewage Ejector System (Latrine).....	40
Table 3.9. Sewage Ejector System (Latrine) Characteristics.....	40
Figure 3.10. Sewage Ejector Lift Station (Kitchen)	41
Table 3.10. Sewage Ejector Lift Station (Kitchen) Characteristics.....	41

Figure 3.11. Dual Pump Life Station.....	42
Table 3.11. Dual Pump Lift Station Characteristics	42
Figure 3.12. Macerator Pump Life Station	43
Table 3.12. Macerator Pump Lift Station Characteristics	43
Figure 3.13. Wastewater Collection Tank with Aeration System	44
Table 3.13. Wastewater Collection Tank System Characteristics	44
Figure 3.14. Water System Hoses, Connector and Valves	45
3.3. BEAR Sanitation Assets	45
Figure 3.15. Shower/Shave Unit.....	46
Figure 3.16. Latrine Unit	47
Figure 3.17. Waste Disposal Trailer	47
Figure 3.18. SHL System Components	48
Chapter 4—MOBILE ELECTRIC POWER AND DISTRIBUTION ..	49
4.1. General Information.....	49
Figure 4.1. Establishing Deployed Power Plant	49
4.2. MEP-805B TQG.....	50
Figure 4.2. MEP-805B Generator.....	50
Table 4.1. MEP-805B Generator Characteristics	50
4.3. MEP-806B TQG.....	51
Figure 4.3. MEP-806B Generator.....	51
Table 4.2. MEP-806B Generator Characteristics	51
4.4. MEP-012A Prime Power Generator	52
Figure 4.4. MEP-012A Generator	52

Table 4.3. MEP-012A Generator Basic Characteristics	52
4.5. Interim Power Unit	53
Figure 4.5. Interim Power Unit.....	53
Table 4.4. IPU Basic Characteristics	53
4.6. Generator Fuel Bladders	54
Figure 4.6. Collapsible Fuel Bladder.....	54
4.7. Electrical Distribution Systems.....	54
Figure 4.7. Primary Switching Center (DRS Radian Model)	55
Table 4.5. PSC Characteristics	55
Figure 4.8. Secondary Distribution Center (Radian Model).....	56
Table 4.6. SDC Characteristics	56
Figure 4.9. 25KW Power Distribution Panel (Radian Model).....	57
Table 4.7. PDP Characteristics (25KW).....	57
Figure 4.10. 60KW Power Distribution Panel (Radian Model).....	58
Table 4.8. PDP Characteristics (60KW).....	58
Figure 4.11. Primary Electrical Distribution Cable and Reel	59
Figure 4.12. Typical Secondary Electrical Distribution Cables.....	60
Table 4.9. Approximate Voltage Drops	60
4.8. Legacy Power Systems	61
Table 4.10. Characteristics of Legacy Generators.....	61
Figure 4.13. Secondary Distribution Center (Model JEU-191E).....	62
Table 4.11. SDC Characteristics (Model JEU-191E).....	62

Chapter 5—HEATING, VENTILATION, AIR CONDITIONING, AND REFRIGERATION (HVAC/R)	63
5.1. General Information.....	63
5.2. Field-Deployable Environmental Control Unit (FDECU)	63
Figure 5.1. FDECU.....	63
Table 5.1. FDECU Characteristics	64
5.3. 130K Portable Heater.....	64
Figure 5.2. 130K Portable Heater.....	65
Table 5.2. 130K Portable Heater Characteristics	65
5.4. H-1 Heater Unit	66
Figure 5.3. H-1 Heater.....	66
Table 5.3. H-1 Heater Characteristics	66
5.5. M-80 Water Heater	67
Figure 5.4. M-80 Water Heater	67
Table 5.4. M-80 Water Heater Characteristics	67
5.6. WH-400 Water Heater.....	68
Figure 5.5. WH-400 Water Heater	68
Table 5.5. WH-400 Water Heater Characteristics	68
5.7. Advanced Design Refrigerator, 300 Cubic Foot (ADR-300) ..	69
Figure 5.6. ADR-300.....	69
Table 5.6. ADR-300 Characteristics	69
5.8. TRICON Refrigerated Container System (TRCS).....	70
Figure 5.7. TRICON Refrigerated Container System.....	70

Table 5.7. TRCS Characteristics	70
5.9. Legacy HVAC/R Systems	71
Figure 5.8. ECU-39	71
Figure 5.9. 1200-CF Refrigeration Unit	72
Figure 5.10. 150-CF Refrigeration Unit	72
Chapter 6—SPECIALIZED ASSETS	73
6.1. General Information.....	73
6.2. Specialized Equipment and Systems.....	73
Figure 6.1. Remote Area Lighting System (RALS)	73
Figure 6.2. TF-2 Light Cart	74
Figure 6.3. Laying AM-2 Matting at Deployed Location.....	74
Figure 6.4. Moving Heavy Rolls of Concertina Wire.....	75
Figure 6.5. MC-2A Diesel-Driven Air Compressor	75
Figure 6.6. EALS Temporary Airfield Lights	76
Table 6.1. EALS II Modules	77
Figure 6.7. Mobile Aircraft Arresting System.....	78
Figure 6.8. Single Pallet Expeditionary Kitchen (SPEK).....	79
Figure 6.9. BEAR 550 Kitchen (550-Personnel).....	80
Chapter 7—NON-BEAR ASSETS	81
7.1. General Information.....	81
7.2. Fuels Operational Readiness Capability Equipment (FORCE).....	81
Figure 7.1. R-18 Trailer-Mounted Pumping Unit.....	82

Figure 7.2. R-19 Trailer-Mounted Filter Separator	82
Figure 7.3. R-20 Multi-Aircraft Servicing Platform.....	83
Figure 7.4. R-21 Portable Hydrant Mission Support Plumbing Assy.....	84
Figure 7.5. Tactical Automated Service Station (TASS).....	84
7.3. Fuels Mobility Support Equipment (FMSE).....	85
Figure 7.6. R-14 Transportable Hydrant Refueling System	85
Figure 7.7. R-22 Trailer-Mounted Transfer Pump	86
Figure 7.8. FFU-15E Skid-Mounted Filter Separator.....	86
Figure 7.9. GRU-17E Aircraft Fuel-Servicing Unit	87
Figure 7.10. PMU-27M Pumping Assembly	88
7.4. Fuel Bladders	88
Figure 7.11. Fuel Bladders in Storage and Distribution Area.....	88
Table 7.1. Collapsible Fuel Bladder Details.....	89
7.5. Expeditionary Medical Support (EMEDS) Facilities	90
Figure 7.12. Expeditionary Medical Support Facility	90
7.6. Aeromedical Staging Facility (ASF).....	91
7.7. Transportable Blood Transshipment Center (TBTC).....	91
Figure 7.13. Patient Evacuation at Aeromedical Staging Facility	92
7.8. Navigational Aids (NAVAIDs)	92
Figure 7.14. Landing Control Central Surveillance Radar System.....	93
Figure 7.15. Mobile Control Tower.....	94
Figure 7.16. Mobile Microwave Landing System	95
Figure 7.17. Tactical Air Navigation Unit.....	95

7.9. International Organization for Standardization (ISO) Containers	96
7.10. Expandable Light Air Mobile Shelter (ELAMS).....	96
Figure 7.18. Expandable Light Air Mobile Shelter	96
Table 7.2. ELAMS Environmental Limitations	96
7.11. K-Span Structures	97
Figure 7.19. K-Span Facility Under Construction.....	97
7.12. Revetments	97
Figure 7.20. B-1 Revetments Layout Plan and Elevation (16-Foot High)	98
7.13. Force Provider Facilities and Equipment.....	99
Figure 7.21. Force Provider Assets	99
Attachment 1—GLOSSARY OF REFERENCES AND SUPPORTING INFORMATION	100
Attachment 2—ENGINEER REACHBACK AND OTHER USEFUL LINKS	111
Attachment 3—BEAR AIR-CONFIGURED UTC DETAILS	112

Chapter 1

INTRODUCTION

1.1. General Information. Long before World War II, leaders in the Army Air Forces recognized the importance of being able to rapidly construct and sustain airfields close to or even behind enemy lines. Over the years, that fundamental understanding of projecting air power precipitated doctrine, organization, training, materiel, leadership and education, personnel, and facilities (DOTMLPF) that continues to evolve today. The Air Force's power projection mission requires that it be able to apply air, space, and cyberspace power anywhere in the world in support of U.S. national interests. In fact, air, space, and cyberspace power can reach across the full spectrum of military operations—from humanitarian assistance missions and stability operations, to the decisive application of air power in support of combat operations around the globe. To that end, the ability to develop a bare base or operating location quickly is an essential part of the USAF power projection mission, and subsequently one of civil engineers' (CE) most important expeditionary and contingency tasks.

1.2. Overview. Like most major construction projects, developing a bare base or operating location to beddown forces require both skilled personnel and suitable materiel to build facilities and infrastructure. Basic Expeditionary Airfield Resources (BEAR) and other assets help fulfill the latter requirement. BEAR is essentially war readiness materiel that is configured and stored ready to deploy. This handbook primarily addresses BEAR assets used during bare base development and force beddown activities. It contains CE tactics, techniques, and procedures (TTPs) that follow the precepts outlined in Air Force Doctrine Document (AFDD) 4-0, *Combat Support*, and AFDD 3-34, *Engineer Operations*, and aids in the implementation of Air Force Policy Directive (AFPD) 10-2, *Readiness*. This relationship is illustrated in the Air Force CE hierarchy of publications (**Figure 1.1**). Prime Base Engineer Emergency Force (Prime BEEF) team leaders, supervisors, and work crews may find this handbook useful during bare base development or beddown operations using BEAR and non-BEAR deployment assets.

Figure 1.1. Air Force Civil Engineer Publications Hierarchy.



Operational Doctrine

AFDD 4-0, Combat Support
AFDD 3-34, Engineer Operations



Policy Directives

AFPD 10-2, Readiness
AFPD 10-25, Emergency Management
AFPD 32-10, Installations & Support
AFPD 32-20, Fire Emergency Services
AFPD 32-30, Explosive Ordnance Disposal
AFPD 32-60, Housing
AFPD 32-70, Environmental Quality
AFPD 32-90, Real Property Asset Management



Tactical Guidance

Air Force Instructions
Air Force Manual
Air Force Pamphlets
Air Force Tactics, Techniques, and Procedures
Air Force Handbooks

1.3. Roles and Responsibilities. Several organizations have important roles and responsibilities for the development, management, and maintenance of BEAR. Some of them are listed in **Table 1.1**. See AFI 25-101, *War Reserve Materiel (WRM) Program Guidance and Procedures*, for a more complete list of BEAR roles and responsibilities.

Table 1.1. BEAR Roles and Responsibilities.

Agency	Roles and Responsibility
General Officer Steering Group (GOSG)	GOSG is chaired by ACC/A4. Principal members include AF/A4/7P; AF/A7C; AF/A4/7Z; WR-ALC/CC, AF/A4L; USAFE/A4; PACAF/A4; AMC/A4; AFSVA/CC; AFMC/A4; AFSOC/A4; and AETC/A4. The GOSG provides executive oversight, policy, and guidance to the BEAR program.
BEAR Systems Readiness Board (BSRB)	BSRB is an O-6 level multi-agency management board chaired by ACC/A4R. The board is responsible for oversight of the BEAR program and provides guidance and direction to the BEAR Integrated Process Team (BIPT).
BEAR Integrated Process Team (BIPT)	BIPT is an action officer level, multi-agency, working group chaired by ACC/A4RX. The BIPT is responsible for managing daily activities involving system requirements, configuration, modernization, sustainment, and resource programming.
Air Combat Command/Global Manager and AF Executive Agent	As Global Manager, ACC/A4 plans, programs, advocates, justifies, and defends current and out-year funding through the corporate process for replacement and modernization of existing BEAR systems and equipment for Using Commands and authorized training requirements.

Table 1.1. (Continued)

Air Force Civil Engineer Support Agency (AFCESA)	Develops contingency planning factors, infrastructure requirements, and conceptual planning guidance for engineers, planners, and developers of BEAR. Evaluates adequacy of BEAR Systems and recommends changes or improvements to the BIPT /BSRB. Develops training standards and curriculum for Silver Flag exercise sites for training personnel on selected BEAR Systems.
49th Materiel Maintenance Group	Develops and maintains standard manpower and Logistics Detail (LOGDET) for every BEAR Unit Type Code (UTC) based on the mission capability of the UTC. Evaluates packaging options and resources (pallets, nets, cargo bins, etc.) for BEAR UTCs and shipping increments to ensure the most efficient packaging methods are used to optimize the deployment footprint. Also coordinates recommended changes to LOGDET with the other BEAR storing and using commands and prepare necessary LOGMOD transactions to reflect accepted changes.
Storing Command	Programs and budget for acquisition of expendable assets and the storage and maintenance of all WRM for bases they have host base responsibility. Report WRM serviceability and availability in accordance with (IAW) Air Force Status of Resources and Training System (SORTS). Coordinate with Using Commands to redistribute/dispose of assets to support force employment or beddown changes, and identify and redistribute excess WRM to fill their command shortages and other command WRM shortfalls.

Table 1.1. (Continued)

Using Command	Determines WRM prepositioning requirements to support the War and Mobilization Plan (WMP-4) and program for initial and replacement WRM Support Equipment (SE) requirements. Responsible for notifying Storing Commands of out-of-cycle WRM requirement adjustments due to operation plan (OPlan)/concept plan (CONPlan) changes. Identify beddown requirement changes and notify Storing Commands when WRM assets are no longer required or are in excess of determined requirement.
---------------	---

1.4. BEAR Accountability. Accurate accountability is key to successful deployment, reception and sustainment of BEAR assets. Proper supply discipline must be maintained for the duration of deployments. Below are some common factors for tracking and maintaining BEAR assets. See AFI 25-101, and command guidance for specific accountability requirements.

1.4.1. Upon equipment transfer, the contingency site civil engineer squadron has overall accountability and responsibility for maintaining BEAR assets. According to AFI 25-101, engineer squadron commanders should sign appropriate documentation and assume responsibility of BEAR equipment assets. When deployed to support theater activities, 49th Materiel Maintenance Group (MMG) personnel and other AF logistics personnel deployed in direct support of BEAR assets assist CE commanders in tracking assets and assigning responsibility to major users (**Figure 1.2.**).

1.4.2. In addition, BEAR Mobility Readiness Spares Packages (MRSP) will be transferred, before each deployment, to the 440th Supply Chain Operations Squadron (440 SCOS), in accordance with AFMAN 23-110, Volume II, Part 2, Chap 26. Transferred MRSPs will be under the control of the contingency site Logistics Readiness Squadron (LRS) until returned to home station. Logistics personnel also account for all BEAR ISO containers using the Army Container Asset Management System (ACAMS), according to AFI 24-203, *Preparation and Movement of Air Force Cargo*.

Figure 1.2. Logistics Personnel Help Keep Track of BEAR Assets.



1.4.3. When BEAR assets are transferred to other services/agencies, they will be handled IAW AFMAN 23-110, Volume II, Part 2, Chapter 22.

1.4.4. All fuel and water bladders should be transferred to the contingency CE squadron commander at the time of deployment. These items are not normally reconstituted after deployment.

1.4.5. A variety of options exist to redeploy BEAR assets, including a BEAR Reconstitution Team (UTC XFAJ1), contractor personnel, or CE personnel. The goal is an orderly breakdown of BEAR assets so they can be redeployed and reconstituted as quickly as possible—important processes to ensure BEAR future contingency operations readiness.

1.4.6. During redeployment preparations, the contingency site BCE and XFAJ1 supply personnel conduct a joint inventory and review accountable documentation. The contingency site BCE must be relieved of accountability before redeploying.

1.4.7. Following contingency use, reconstitution is generally conducted for all BEAR equipment, vehicles, and MRSPs by the storing MAJCOM.

1.5. Equipment Packaging and Configurations. In recent history, bare base beddown and sustainment equipment has undergone significant changes to the way it is packaged and configured for deployment. Equipment sets formerly known as Harvest Eagle and Harvest Falcon transitioned to BEAR equipment and housekeeping sets. Today, these BEAR sets are being converted to capabilities-based UTC packages under the BEAR Order of Battle (BOB) concept (**Figure 1.3.**). The goal is to further refine the priority and sequencing of delivered assets and make improvements in equipment configurations that create efficiencies and enhance flexibility and responsiveness. Although, the major difference between these new air- and surface-configured BOB UTCs (**Table 1.2.**) is packaging, equipment contents do vary between some of them. Users should refer to appropriate UTC Management or Manpower and Equipment Force Packaging (MEFPAK) databases or see their Unit Deployment Manager (UDM) for current information.

Figure 1.3. BEAR to BOB Reconfiguration.

BEAR (550 – 3300 Personnel)	BOB (250 – 3500 Personnel)	
<ul style="list-style-type: none"> Built in 550 person increments 	<ul style="list-style-type: none"> Built in 250 person increments and/or desired capability 	
3 x B-550 Initial Housekeeping Set (XFB1H)		
Billeting <ul style="list-style-type: none"> Shower/Shave Latrines Low and High Voltage Water Distribution Camp Lighting Limited Infrastructure Mortuary/Tact. Field Exchange /Chaplin 	<ul style="list-style-type: none"> Billeting UTC ECUs UTC Showers/Latrines UTC Messing UTC SDCs UTC Power (Low Voltage) UTC Power (High Voltage) UTC Power Distribution UTC External Lighting UTC Water Distro (initial) UTC Water Distro (Follow-On) UTC Chaplin UTC Supply UTC Mortuary UTC Tactical Field Exchange UTC 	<ul style="list-style-type: none"> CE Support UTC Admin Support UTC
3 x B-550 Follow-On Housekeeping Set (XFBBF)		
<ul style="list-style-type: none"> Billeting Water System Latrines Shower/Shave Additional Power 		
<ul style="list-style-type: none"> Large UTCs, non-modular, heavy lift requirement 	<ul style="list-style-type: none"> Small, Modular UTCs by functional capability 	
<ul style="list-style-type: none"> Difficult “breaking” kits Low visibility of tailoring Tough to define residual capability 	<ul style="list-style-type: none"> Enables easy/flexible site-specific taskings Extreme flexibility for mode of transportation/sequence/ timing <p style="text-align: center;">Efficiencies in packing, delivery, and usage!</p>	

Table 1.2. BOB Air and Surface Equipment UTCs.

Air Configured UTC *	ASSET	Surface Configured UTC
XFA14	Combat Air Forces (CAF) Initial (8 Medium/8 Small Shelters)	XFS14
XFA16	Low Voltage Industrial (2 MEP-806's)	XFS16
XFA17	Water Distribution Initial	XFS17
XFA18	Water Distribution Follow-On	XFS18
XFA19	Engineering Management (2 Small Shelters)	XFS19
XFA21	Power Pro/CE Sup/Elect (3 Small Shelters)	XFS21
XFA23	TF-2 Lightcart (2 TF-2's)	XFS23
XFA3C	Mobility Air Forces (MAF) Initial (6 Medium/8 Small Shelters)	XFS3C
XFAAB	4K Dome (1 Shelter)	XFSAB
XFAAC	Field-Deployable Environmental Control Unit (FDECU), 12 Ea.	XFSAC
XFAAD	8K Dome (1 Shelter)	XFSAD
XFAAM	AM2 Matting (6 Bundles)	XFSAM
XFABL	Billeting (12 Small Shelters)	XFSBL
XFAC6	CAF Add-On (2 Medium/1 Small Shelter)	XFSC6
XFACB	CAF Follow-On (4 Small Shelters)	XFSCB
XFACC	Tactical Exchange (1 Small Shelter)	XFSCC
XFACD	Entomology (No Facility)	XFSCD
XFACF	Fire Ops/Crash Rescue (4 Small Shelters)	XFSCF
XFACH	Advanced Design Refrigerator, 300 CF (ADR-300), 1 Ea.	XFSCH
XFACJ	Large Area Maintenance Shelter (LAMS) 1 Ea.	XFSCJ
XFACL	Barrier Facility (1 Medium Shelter)	XF_SCL

Table 1.2. (Continued)

XFACW	Cold Weather (12 Heaters)	XFSCW
XFACX	CE Maintenance (1 Small Shelter)	XFSCX
XFAEC	CE Industrial (1 Small Shelter)	XFSEC
XFAEG	Power Distribution (2 Cable Reel Pallet Assy.)	XFSEG
XFAGC	Chaplain (1 Small Shelter)	XFSGC
XFAHL	High Line Dock (1 HLD)	XFSHL
XFAKC	Kitchen	XFSKC
XFALC	Shower/Shave/Latrine (2 Small Shelters)	XFSLC
XFALS	Self Help Laundry	XFSLS
XFAMP	Water Production, 1500-GPH Reverse Osmosis Water Purification Unit (ROWPU), 2 Ea.	XFSPMP
XFAMS	Water Source Run	XFSMS
XFAMU	Munitions (1 Medium/1 Small Shelter)	XFSMU
XFAMX	Water Extension	XFSMX
XFANC	Camouflage Netting, 200 Ea.	XFSNC
XFAND	Water Production, 600-GPH ROWPU, 3 Ea.	XFSND
XFAPH	High Volt Power (2 MEP-12's; 2 10K Fuel Bladders; 1 Primary Switching Center (PSC); 1 Operating Remote Terminal (ORT)	XFSPH
XFAPL	Low Voltage Housekeeping (5 MEP-806's; 3 MEP-805's)	XFSPPL
XFAPS	Postal (1 Medium Shelter; 1 FDECU)	XFSPs
XFAR4	Mobile Aircraft Arresting System (MAAS), 1Ea.	XFSR4
XFARB	Packing/Crating (No Facility)	XFSRB
XFASC	Combat Supply (4 Small Shelter)	XFSSC
XFASD	Secondary Distribution Center (SDC's), 2 Ea.	XFSSD
XFATF	Single-Pallet Expeditionary Kitchen (SPEK) Messing	XFSTF

Table 1.2. (Continued)

XFAVC	Vehicle Maintenance/Operations (1 Small Shelter)	XFSVC
XFAWC	Admin (4 Small Shelters)	XFSWC
XFAWR	Concertina Wire (480 Rolls)	XFSWR
XFAXN	Mortuary (1 Small Shelter)	XFSXN
XFAYC	Expeditionary Airfield Lighting System (EALS), 1 Ea.	XFSYC
XFAZC	Remote Area Lighting System (RALS), 2 Ea.	XFSZC
XFB1A	Swift BEAR	
* See Attachment 3 for a detailed listing (minus packing and shipping materials) of air-configured BOB UTCs. For complete air- and surface-configured UTC equipment listings, contact your UDM or the AFCESA Reach-Back Center.		

1.6. Equipment Repairs. BEAR assets are generally repaired according to technical order requirements and specifications. Replacement parts and kits are contained in MRSPs or ordered through supply channels. Consult applicable technical order (T.O.) references in **Attachment 1** for specific information. Other reach-back resources are listed in **Attachment 2**.

1.7. Additional Information. For information on siting, installation, operation, maintenance, and use of bare base assets, refer to the Air Force Handbook (AFH) 10-222 series and applicable technical data or manuals. In addition, contact the Air Force Civil Engineer Support Agency (AFCESA) Reach-Back Center when looking for information not found in this publication or the references in **Attachment 1**. Contact the Reach-Back Center at 888-232-3721 (toll free), Defense Switched Network (DSN) 523-6995, or via email at afcesareachbackcenter@tyndall.af.mil.



Chapter 2

SHELTERS

2.1. General Information. The purpose of most shelters is to provide protection from the elements. As a rule, BEAR shelters are employed during times of war, natural disaster, or other emergency or contingency when no other form of acceptable protection is available (**Figure 2.1.**). They provide basic protection for troops deployed to austere locations or areas with limited or no facility support. This chapter highlights current BEAR shelters, non-BEAR shelters, and legacy shelters used during bare base development and force beddown operations. Refer to AFH 10-222, Volume 6, *Guide to Bare Base Facility Erection*, and applicable technical data for detailed guidance on erection, maintenance, and disassembly.

Figure 2.1. Erecting Shelters at Forward Operating Location.



2.2. BEAR Shelters.

2.2.1. Small Shelter System (SSS). The small shelter system (**Figure 2.2.**) is an all-purpose tent-type shelter used for billeting, work areas, latrines and showers, storage, etc. When fully erected, this shelter measures 32.5 feet long by 20 feet

wide by 10 feet high (650 sq ft). The SSS is equipped to accept 120/208 volts alternating current (VAC), 60-cycle, single-phase power. The SSS is designated as the replacement for the TEMPER tent through attrition. Compared to the TEMPER tent, it is slightly lighter, tighter, and more vector proof. It also requires less day-to-day maintenance when erected, and its fabric is easier to repair. Six people can safely assemble the SSS in about 1.5 hours (nine labor hours). If required, multiple buildings can be interconnected. Environmental limitations of the SSS are listed in **Table 2.1**. See T.O. 35E5-6-11, *Alaska Small Shelter System (AKSSS)*, and AFH 10-222, Volume 6, for siting and erection procedures.

Figure 2.2. Small Shelter System.



Table 2.1. SSS Environmental Limitations.

Temperature	-25° F to 125° F
Wind Load (Sustained)	50 knots
Wind Load (Gusts)	Up to 60 knots

2.2.2. Medium Shelter System (MSS). The medium shelter system (**Figure 2.3.**) is an all-purpose, mid-sized shelter suitable for any environment or bare base mission with only normal organic support provided. The MSS is 52 feet long by 29.5 feet wide by 15 feet high (1,534 sq ft) and often used in maintenance, warehouse, storage and kitchen areas. The shelter is shipped and stored in its own containers and may be erected over soil, asphalt, or concrete. This shelter has a 120/208 VAC, 60-cycle, 3-phase, 5-wire electrical input connection. The MSS is replacing the General Purpose Shelter in the inventory. It provides tighter protection against dust and insects; has lower maintenance costs and takes up less shipping space. A minimum of six people can safely assemble this structure in about 4 hours (24 labor hours) and multiple shelters can be interconnected. Environmental limitations of the MSS are listed in **Table 2.2.** Consult T.O. 35E5-6-21, *California Medium Shelter System*, and AFH 10-222, Volume 6, for more details.

Figure 2.3. Medium Shelter System.



Table 2.2. MSS Environmental Limitations.

Temperature	-25° F to 125° F
Wind Load (Sustained)	60 knots
Wind Load (Gusts)	Up to 90 knots

2.2.3. Bare Base Dome Shelter. The dome shelter (**Figure 2.4.**) is a large, all-purpose shelter used as a maintenance area, warehouse, or aircraft hangar. It is available in three sizes; 4K and 8K square feet, and can be extended in length indefinitely by adding additional modules. Each length module adds approximately 13-1/2 feet. Shelters receive a 120/208 VAC, 60-cycle, 3-phase, 5-wire electrical input. Although RED HORSE and 49th MMG teams may have the lead when erecting dome shelters, Prime BEEF can expect to assist. The shelter can be erected and disassembled from ground level and all tools necessary for erection and disassembly are included in the shelter package. It can also be installed on concrete and secured with thunder studs. At least eight people are required to assemble the structure safely. Assembly time is approximately 256 man-hours. Environmental limitations of the dome shelter are listed in **Table 2.3.** Consult T.O. 35E4-216-1, *Bare Base Dome Shelter*, for more details.

Figure 2.4. Bare Base Dome Shelter.



Table 2.3. Dome Shelter Environmental Limitations.

Temperature	-25° F to 125° F
Solar Load	200° F
Wind Load (Sustained)	60 knots
Wind Load (Gusts)	Up to 90 knots

2.2.4. Large Area Maintenance Shelter (LAMS). The LAMS (**Figure 2.5.**) provides semi-portable housing for small aircraft and vehicle maintenance. Sized at approximate 129 feet long, 75 feet wide, and with a 31-foot height clearance at the center, it has electrically operated Clamshell end-doors at both ends. The shelter is equipped with Class I, Div. 1, Group C Electrical System (explosion proof lights, outlets, wiring, and switches). The overall area required to erect the hangar is approximately 100 feet x 135 feet. It can be erected on a reinforced concrete pad (100 feet minimum x 135 foot minimum x 8 to 10 inch thick), asphalt, or earth surface. Once erected, the LAMS provide an unobstructed, weatherproof work area free of vertical supports that could hinder movement of aircraft and equipment within. A minimum of ten people are required to assemble the structure safely. Assembly time is approximately 300 man-hours. Environmental limitations of the LAMS are listed in **Table 2.4.** Consult T.O. 35E4-219-1, *Large Area Maintenance Shelter*, for additional information.

Figure 2.5. Large Area Maintenance Shelter.



Table 2.4. LAMS Environmental Limitations.

Temperature (Operate)	-20° F to 120° F
Wind Load	(set-up) 25 mph (closed shelter w/guy lines in place) 90 mph (operate clam shell door) See T.O. 35E4-219-1
Snow Load	8 lbs per square foot w/o snow kit

2.3. Legacy Shelters.

2.3.1. Frame-Supported Tensioned Fabric Shelter (FSTFS). The frame-supported tensioned fabric shelter (**Figure 2.6.**) is a large, all-purpose shelter used as a maintenance area or warehouse. It is available in two configurations; type A and type B shelters. The type A shelter has a minimum usable interior floor space of 60 feet by 140 feet (8400 square feet). The type B shelter has a minimum usable floor space of 60 feet by 70 feet (4200 square feet). Both shelters are portable and rapidly deployable, and require no concrete foundation. A minimum of eight people can assemble the structure safely. Assembly time is approximately 384 man-hours for type A shelters and 256 man-hours for type B. If necessary, multiple buildings can be interconnected. FSTFSs are gradually being replaced by the Dome Shelters, which provide more utility and versatility. Environmental limitations of the FSTFS are listed in **Table 2.5.** See T.O. 35E4-183-1, *Frame-Supported Tensioned Fabric Shelter*, for detailed descriptions.

Figure 2.6. Frame-Supported Tensioned Fabric Shelter.

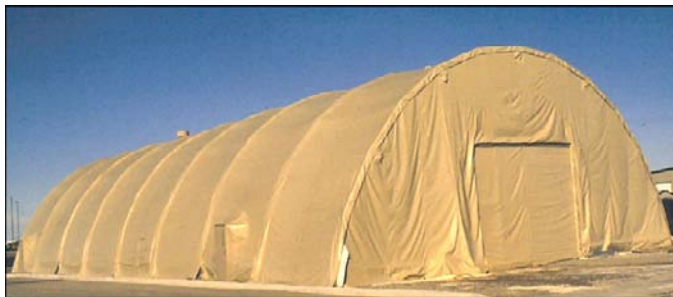

Table 2.5. FSTFS Environmental Limitations.

Temperature	-25° F to 125° F
Solar Load	200° F
Wind Load (Sustained)	60 knots
Wind Load (Gusts)	Up to 90 knots

2.3.2. General Purpose (GP) Shelter. The GP shelter (**Figure 2.7.**) is approximately 48 feet long by 31 feet wide by 12 feet high, and can be used for a variety of bare base functions, including personnel shelters or aircraft support activities, (e.g. machine/welding shop, wheel shop, etc.). The erected shelter provides over 1400 square feet of unobstructed floor area. Lighting and service outlets are provided through a distribution panel and cable arrangement on each side of the shelter. A crew of six can erect the shelter on a prepared surface in about 15 hours, or about 20 hours if installed with a floor. The 49th MMG's four-person large structures team can provide technical experts to assist with erection, striking, or packing the GP shelter. The GP shelter is being replaced through attrition by a softwalled, medium shelter system. Environmental limitations of the GP shelter are listed in **Table 2.6.** Consult T.O. 35E4-132-1, *Bare Base General Purpose Shelter*, for proper shelter erection procedures.

Figure 2.7. General Purpose Shelter.

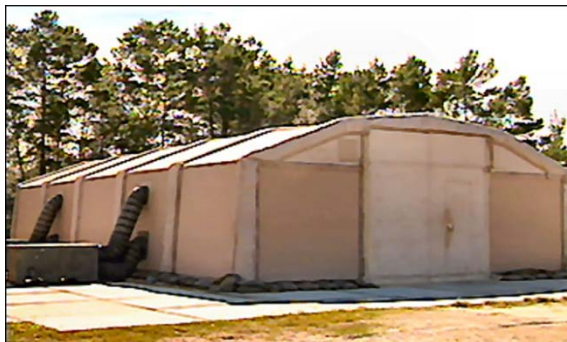

Table 2.6. GP Shelter Environmental Limitations.

Temperature	-25° F to 125° F
Solar Load	200° F
Wind Load (Sustained)	50 knots
Wind Load (Gusts)	Up to 60 knots

2.3.3. Expandable Shelter Container (ESC). The ESC is used primarily for flightline and industrial shops (**Figure 2.8.**). When expanded, the ESC measures approximately 21 feet long by 13 feet wide by 8 feet high and weigh 12,500 pounds when shipped without an internal payload. Double doors (cargo doors) are installed in one end wall of the center section and a personnel door in the other end wall. Double pane windows in the walls are non-opening, shatterproof, heat resistant and equipped with blackout curtains. A complete 3-phase electrical system with installed lighting is provided. A crew of six can erect the ESC in approximately two hours. Environmental limitations of the ESC are listed in **Table 2.7.** Consult AFH 10-222, Volume 6, and for specific set-up instructions.

Figure 2.8. Expandable Shelter Container.



Table 2.7. ESC Environmental Limitations.

Temperature	-25° F to 125° F
Solar Load	200° F
Wind Load	60 knots (Sustained) Up to 90 knots (Gusts)
Snow Load	40 lbs per square inch
Floor Load	120 lbs per square inch (Center) 80 lbs per square inch (Expanded)

2.3.4. **Aircraft Maintenance Hangar (ACH).** The ACH is a lightweight structure intended for use as an aircraft maintenance shelter during bare base deployment (**Figure 2.9.**). The hangar consists of seven arches and two endwalls providing 8,225 square feet under roof. The main structure consists of 80 rigid panels mounted on beams that form the seven arches. The four shipping and storage containers are installed in the corners of the hangar for personnel access to the hangar, equipment storage, and office space. Both hangar endwalls can be raised and lowered to permit aircraft and vehicle entry. An electrical system provides inside and outside lighting and power outlets for the containers, bare base heating system, and the hangar work area. Erecting the ACH requires a minimum of 10 people and generally takes about 40 hours (400 labor hours). Environmental limitations of the ACH are listed in **Table 2.8.** See T.O. 35E4-133-1, *Bare Base 76-Foot Aircraft Maintenance Hangar*, for more information on siting and erection procedures.

Figure 2.9. Aircraft Maintenance Hangar.



Table 2.8. ACH Environmental Limitations.

Temperature	-25° F to 125° F
Solar Load	200° F
Wind Load (Sustained)	60 knots
Wind Load (Gusts)	Up to 90 knots

2.3.5. Tent Extendable Modular Personnel (TEMPER). The TEMPER is a frame-supported shelter consisting of a collapsible aluminum frame covered with a coated polyester fabric (**Figure 2.10.**). This all-purpose shelter is used for billeting, offices, storage, shower/shaves, latrines, kitchen and dining, and other functions. Tent modules come in 8 foot by 20-foot sections that fasten together; the nominal tent size is 32 feet by 20 feet x 11 feet (640 sq ft tent). A tent fly is used to reduce solar loading and provide increased environmental protection. A minimum of six people are required to safely assemble this shelter in about 1.5 hours (9 labor hours). Environmental limitations are listed in **Table 2.9.** Consult T.O. 35E5-6-1 and AFH 10-222, Volume 6, for detailed information on this shelter.

Figure 2.10. Tent Extendable Modular Personnel.

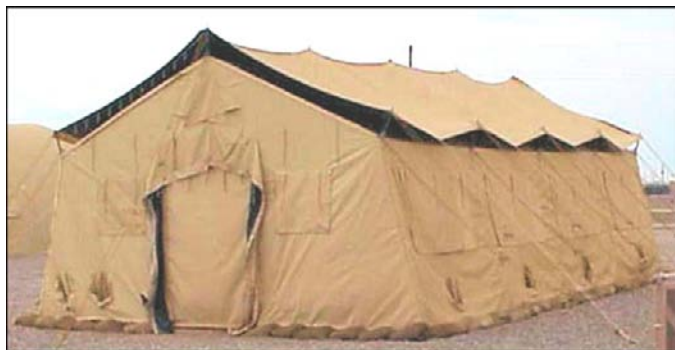

Table 2.9. TEMPER Environmental Limitations.

Temperature	-25° F to 125° F
Wind Load (Sustained)	50 knots
Wind Load (Gusts)	Up to 60 knots



Chapter 3

WATER AND SANITATION

3.1. General Information. Water distribution systems and sanitation facilities are essential for the health and morale of personnel at expeditionary bases. Water systems collect and purify raw water; stores and distributes potable water; and collects and distributes wastewater for disposal. Sanitation facilities include latrines, showers/shave apparatus, and laundries. This chapter provides a brief description of current BEAR water system components and sanitation facilities used during bare base development and force beddown operations. Legacy equipment still in use will also be addressed.

3.2. BEAR Water System. The BEAR water system consists of five distinct subsystems; source run, water production, initial, follow-on, and industrial operation and flightline extension subsystems. The system is modular in design and scalable to meet a variety of user deployment needs. System components include reverse osmosis water purification units (ROWPU), water storage tanks, pumps, hoses, fluid control devices and connectors, lift stations, and various other equipment items and components. Some of these items will be discussed here. Refer to AFH 10-222, Volume 11, *Contingency Water System Installation and Operation*, T.O. 40W4-21-1, *Basic Expeditionary Airfield Resources (BEAR) Water System*, and other technical orders listed in this chapter and **Attachment 1** for additional information.

3.2.1. ROWPU. The ROWPU is a mobile water purification unit that produces potable water by removing suspended and dissolved solids from seawater or fresh water. The 1500 ROWPU (**Figure 3.1.**) produces potable water at a capacity equal to or greater than 1500 gallons per hour (GPH), and requires up to 35 kilowatts (kW) of power from an external source. It can produce potable water for 20 hours per day; the remaining four hours are used for backwashing and maintenance. The ROWPU operation produces up to two gallons of brine water for each gallon of potable water. Brine water can be used for grounding pads, construction or dust control; piped into its own evaporation lagoon; or returned to a large body of water. The use of brine water for dust control must be approved by area medical authorities IAW AFMAN 48-138 (IP), *Sanitary*

Control and Surveillance of Field Water Supplies. See **Table 3.1.** for other ROWPU particulars. For additional information on the ROWPU, see AFH 10-222, Volume 9, *Reverse Osmosis Water Purification Unit Set-Up and Operation*, and T.O. 40W4-20-1, *Operation and Maintenance Instructions, 1500 Reverse Osmosis Water Purification Unit (ROWPU)*.

Figure 3.1. 1500 ROWPU.



Table 3.1. 1500 ROWPU Particulars.

Dimensions (L/W/H)	104 x 88 x 84 in.
Weight (dry)	8000 lbs.
Power	35kW
Voltage	208 VAC
Frequency	60Hz
Current	104 amp (max)

3.2.2. Water Storage Tanks. Water storage tanks are portable, collapsible fabric tanks used to store raw or potable water, brine, or wastewater from water production operations. BEAR water tanks are available in two sizes, 20,000-gallon and 3,000-gallon. The 20,000-gallon tanks (**Figure 3.2.**) are generally used at water production and water storage facilities. The 3,000-gallon tanks (**Figure 3.3.**) are mostly positioned near user facilities; however, one of the tanks is used to collect ROWPU wastewater. See **Table 3.2.** and **Table 3.3.** for other tank characteristics and information.

Figure 3.2. 20,000-Gallon Fabric Water Tank.



Table 3.2. 20,000-Gallon Tank Characteristics and Information.

Dimensions	24 x 28 ft. (empty)
Weight	1120 lbs. (empty)
Capacity	20,000 gal.
Uses	Raw, potable, and brine water at production and storage facilities (tanks are not inter-changeable)
Technical Data	TM 5-5430-236-13, <i>Operator's, Unit, and Direct Support Maintenance Manual, 20,000 Gallon Collapsible Fabric Tank</i>

Figure 3.3. 3,000-Gallon Fabric Water Tank.**Table 3.3. 3,000-Gallon Tank Characteristics and Information.**

Dimensions	13.75 x 13.75 ft. (empty)
Weight	197 lbs. (empty)
Capacity	3,000 gal.
Uses	Potable water at user facilities and ROWPU wastewater (tanks are not interchangeable)
Technical Data	T.O. 40W4-21-1

3.2.3. Water Pumps. Several water-pumping devices are used within the BEAR water system. They include the 400-gallons per minute (GPM), 125-GPM, and 35-GPM Pump Assemblies, Dual Pump Station, and Bladder Water Level Controllers.

3.2.3.1. **400-GPM Diesel Pump Assembly.** The 400-GPM pump assembly is a trailer mounted, diesel driven, centrifugal, self-priming pump (**Figure 3.4.**). It is capable of producing 400 GPM of water at 300-foot maximum head from a raw water source to the Source Run System storage tank. The trailer, which enables ease of movement of the diesel pump, can be towed at speeds up to 20 mph. A pintle hook at the rear of the trailer can be used for towing of additional units of similar weight. See **Table 3.4.** for other pump characteristics.

Figure 3.4. 400-GPM Diesel Pump Assembly.



Table 3.4. 400-GPM Diesel Pump Characteristics.

Dimensions	97 x 87 x 77-3/4 in
Weight	3,200 lbs.
Capacity	400 gpm at 300 ft. Head
Horse Power	36
Fuel	Diesel
Technical Data	T.O. 40W4-21-1

3.2.3.2. 35-GPM Electric Pump Assembly. The 35-GPM pump assembly (**Figure 3.5.**) is powered by an electric motor coupled to a centrifugal, self-priming pump. Two of these pumps are supplied with the BEAR water system. The first pump assembly is used to pump ROWPU wastewater to a waste disposal area when prime power is available. This pump is manually regulated for waste disposal operations. The second pump assembly is supplied with the Industrial Operations and Flightline Extension Subsystem, and is used to pump potable water up to 2500 feet to fill the facility potable water storage tank. An accumulator tank and pressure switch at the pump outlet is set to control pump operation for output flow regulation between 20 and 40 PSI. **Table 3.5.** lists other characteristics of the pump assembly.

Figure 3.5. 35-GPM Electric Pump Assembly.



Table 3.5. 35-GPM Electric Pump Assembly Characteristics.

Dimensions	27-1/2 x 31-3/4 x 25-3/4 in.
Weight	155 lbs.
Capacity	35 gpm at 40 psi
Horse Power	2 hp
Voltage Requirements	208 V, 1 phase, 60 Hz
Technical Data	T.O. 40W4-21-1

3.2.3.3. 125-GPM Diesel Water Pump Assembly. The 125-GPM diesel pump assembly (**Figure 3.6.**) is a diesel driven, centrifugal, self-priming pump. Three pump assemblies are supplied with the BEAR water system; one pump is used for raw water input distribution and another pump is used in potable water input distribution to fill three 20,000-gallon collapsible fabric tanks. The third pump is for wastewater output distribution and is used when prime power is inadequate or unavailable. To prevent contamination of the water system, these pumps are not interchangeable. Refer to **Table 3.6.** for additional pump details.

Figure 3.6. 125-GPM Diesel Pump Assembly.



Table 3.6. 125-GPM Diesel Pump Characteristics.

Dimensions	22 x 26 x 19 in.
Weight	160 lbs.
Capacity	125 gpm at 50 ft. Head
Horse Power	6
Fuel	Diesel
Technical Data	T.O. 40W4-21-1

3.2.3.4. Dual Pump Station. The dual pump station (**Figure 3.7.**) is used to pressurize the base's potable water distribution lines and maintain chlorination of the water. The two pumps are parallel configured, enabling dual or single pump operation, and single pump isolation for maintenance or repair purposes. Either pump is capable of maintaining water pressure within the loop distribution line. See **Table 3.7.** for additional characteristics.

Figure 3.7. Dual Pump Station.



Table 3.7. Dual Pump Station Characteristics.

Dimensions	84 x 60 x 74 in.
Weight	2,538 lbs.
Capacity	400 gpm at 40 to 50 psi
Voltage Requirements	208 V, 3 phase, 60 Hz
Technical Data	T.O. 40W4-21-1

3.2.3.5. Bladder Water Level Controller. Bladder water level controllers (**Figure 3.8.**) are used to maintain a preset maximum and minimum volume of water in the 3,000-gallon collapsible fabric tanks. All water tanks (bladders or vessels) that are inserted into the water distribution loop or downstream but connected to the Dual Pump Station must have a bladder water level controller or be manually filled. Bladder water level controllers should be connected to an adequate power source at each 3,000-gallon potable water tank. Specific characteristics for the controller are listed in **Table 3.8.**

Figure 3.8. Bladder Water Level Controller.



Table 3.8. Bladder Water Level Control Characteristics.

Dimensions	20 x 20 x 20 in.
Weight	66 lbs.
Technical Data	T.O. 40W4-21-1
Water Flow Regulation	
Input Valve Open	500 to 1000 gallons
Input Valve Closed	Bladder Full

3.2.4. **Sewage Ejector System (Latrine).** The sewage ejector system (**Figure 3.9.**) is a wet pit sump pump that pumps raw sewage from latrines for output distribution to the wastewater collection tank. The ejector system consists of a submersible sewage ejector pump, a float switch, discharge pipe assembly, vent, and structural foam basin. See **Table 3.9.** for basic characteristics.

Figure 3.9. Sewage Ejector System (Latrine).



Table 3.9. Sewage Ejector System (Latrine) Characteristics.

Dimensions	36 x 30 in.
Weight	130 lbs.
Technical Data	T.O. 40W4-21-1
Pump	
Revolutions per Minute (RPM)	1750
Capacity	160 gpm at 18 ft. Head
Horse Power	1
Impeller Type	2 vane non-clog
Voltage Requirement	115 V, 1 phase, 60 Hz
Full Load Current	11.5 Amps

3.2.5. Sewage Ejector Lift Station (Kitchen). The sewage ejector lift station is a wet pit sump pump used to pump kitchen waste to the wastewater collection tank (**Figure 3.10**). Although similar in appearance to the latrine sewage ejector system, these units are not interchangeable. Basic characteristics of sewage ejector lift station are listed in **Table 3.10**.

Figure 3.10. Diagram for Sewage Ejector Lift Station (Kitchen).

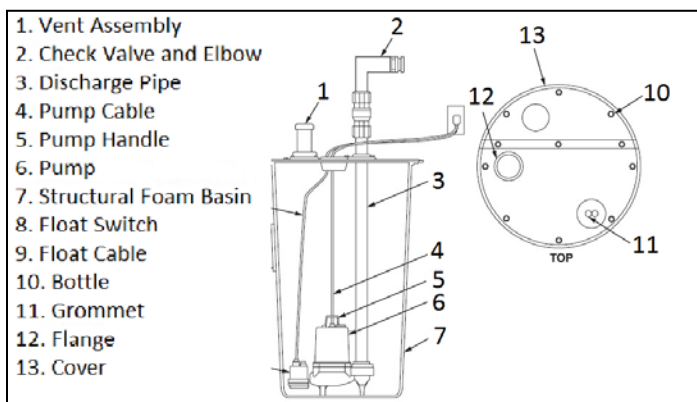

Table 3.10. Sewage Ejector Lift Station (Kitchen) Characteristics.

Tank Dimensions	30.12 x 21.7 in
Weight	102 lbs.
Technical Data	T.O. 40W4-21-1
Pump	
RPM	1750
Capacity	140 gpm at 27 ft. Head
Horse Power	6/10
Impeller Type	Semi-open 2 vane
Voltage Requirement	115 V, 1 phase, 60 Hz
Full Load Current	12 Amps

3.2.6. Dual Pump Lift Station. The dual pump lift station (**Figure 3.11.**) is used for wet pit sump, pre-digestion of raw sewage, and pumping of wastewater to the wastewater collection tank. The two pumps can operate in either dual or single pump configuration. See **Table 3.11.** for more pump details.

Figure 3.11. Dual Pump Lift Station.



Table 3.11. Dual Pump Lift Station Characteristics.

Tank Dimensions	60 x 60 in.
Weight	1,820 lbs.
Technical Data	T.O. 40W4-21-1
Pump	
RPM	3450
Capacity	100 gpm at 144 ft. Head
Impeller Type	Semi-open 5 vane
Voltage Requirement	208 V, 3 phase, 60 Hz
Full Load Current	5 Amps

3.2.7. Macerator Pump Lift Station. These pump lift stations (**Figure 3.12.**), are used for wet pit sump, pre-digestion of raw sewage, and pumping of wastewater from user facilities for distribution to the wastewater collection tank. The lift station consists of a submersible macerator pump, sewage tank, pump lift-out assembly, three floats, and associated plumbing and electrical junction box. Specific characteristics for the macerator pump lift station are listed in **Table 3.12.**

Figure 3.12. Macerator Pump Lift Station.



Table 3.12. Macerator Pump Lift Station Characteristics.

Tank Dimensions	36 x 84 in.
Weight	750 lbs.
Technical Data	T.O. 40W4-21-1
Pump	
RPM	3450
Capacity	100 gpm at 144 ft. Head
Impeller Type	Semi-open 5 vane
Voltage Requirement	115 V, 1 phase, 60 Hz
Full Load Current	5 Amps

3.2.8. 25,000-Gallon Wastewater Collection Tank System. The 25,000-gallon wastewater collection tank (**Figure 3.13.**) provides a 25,000-gallon storage capacity and includes an aerator and pump assembly to mix and aerate wastewater to maintain liquid state for disposal. See **Table 3.13.** for additional tank and aerator details.

Figure 3.13. Wastewater Collection Tank with Aeration System.



Table 3.13. Wastewater Collection Tank System Characteristics.

Tank Dimensions	31 x 5 ft.
Weight	2,335 lbs. (empty)
Capacity	25,000 gallons
Aerator Voltage Requirements	208 V, 3 phase, 60 Hz
Technical Data	T.O. 40W4-21-1

3.2.9. Various Hoses, Connectors and Valves. The BEAR water system has a variety of hose assemblies, connectors, and ball valves for water distribution and control (**Figure 3.14.**). The hoses and connectors have various sizes and diameters and they route potable water input for storage, potable water distribution to user facilities, and wastewater for disposal. Various-sized ball valves control water flow; including potable water input for storage, isolation of storage bags for maintenance or repair actions, and isolation of user facility branch feeds from the water distribution line.

Figure 3.14. Water System Hoses, Connectors and Valves.

3.3. BEAR Sanitation Assets. The health and hygiene of troops in a deployed environment is always a major concern for supervisors and leaders. Sanitation facilities; such as shower and shave units, latrines, and laundries are essential for the health, morale, and safety of base personnel. The following paragraphs provide a brief description of BEAR sanitation assets. Refer to T.O. 35E35-5-1, *Field-Deployable Latrine Assembly*, T.O. 35E35-4-1, *Shower Facility, Bare Base*, T.O. 35E35-3-1, *Shave Stand, Bare Base*, T.O. 50D1-4-11, *Self-Help Laundry*, and other applicable technical data for detailed guidance on BEAR sanitation assets and facilities.

3.3.1. Shower/Shave Units. Portable shower/shave units (**Figure 3.15.**) are included in the BEAR equipment packages. Each shower consists of a base assembly with two stalls, a top frame assembly with attached showerheads, side supports, and a fabric cover. Six shower units can be joined to make a 12-person facility. Doors are provided to close in the two open ends of the facility. The shave stand consists of a base unit with 3 sinks, a mirror back with 3 mirror surfaces, electric light, and 115 VAC outlet, and associated wiring harness and plumbing. Four shave stands are provided for each shower/shave facility. The

shower/shave facility is usually housed in a small shelter system or TEMPER tent. The kit requires one environmental control unit (ECU) for heating/cooling in extreme conditions. A locally purchased ventilation fan may be sufficient in moderate environmental conditions. Site the shower/shave unit on a relatively level surface that is free of debris. Construct a concrete floor for long-term deployments. Set up requires a minimum of four people approximately 6 hours (plus tent and water heater set up).

Figure 3.15. Shower/Shave Unit.



3.3.2. Field-Deployable Latrines. The field-deployable latrine consists of two latrine units. Each unit has six toilets, a urinal trough, two hand-washing sinks, pump unit, 500-gallon collapsible water tank, and a 360-gallon waste tank (**Figure 3.16.**). Setup (not including the shelter) takes two people about one hour. During the early stages of a deployment, the latrine can be operated in a stand-alone mode. That is, the water tank is periodically replenished and the waste tank is emptied using a wastewater disposal trailer. Once water and waste distribution systems are in place, the unit can be connected directly to the service lines. The latrine should be sited on a relatively level surface that is free of debris. Construct a concrete floor for long-term deployments.

Figure 3.16. Latrine Unit.



3.3.3. Wastewater Disposal Trailer. The trailer is a 1,000-gallon mobile sewage tank and vacuum pump (**Figure 3.17.**) used for cleaning latrine holding tanks until they can be connected to the base distribution system. The trailer requires a heavy truck with a pintle hook for towing. Waste must be emptied into a lagoon, commercial sanitary sewer or uninhabited area downwind from the base and away from drinking water sources.

Figure 3.17. Wastewater Disposal Trailer.



3.3.4. Self-Help Laundry. The self-help laundry (SHL) is designed for rapid deployment and continuous operation as a complete field laundry. It consists of five washers, five double stacked dryers, water heater, water tank, supply pump, drain pump, electrical distribution panels, hoses, valves, filters and electrical cables. The washers, dryers and electrical connection boxes are operated within an area approximately 32 feet long by 20 feet wide (small shelter system or TEMPER tent). The pumps, water heater, and tanks are positioned outside the tent. SHL components are illustrated in **Figure 3.18**. The set also includes benches, folding tables and temporary hanging racks.

Figure 3.18. SHL System Components.

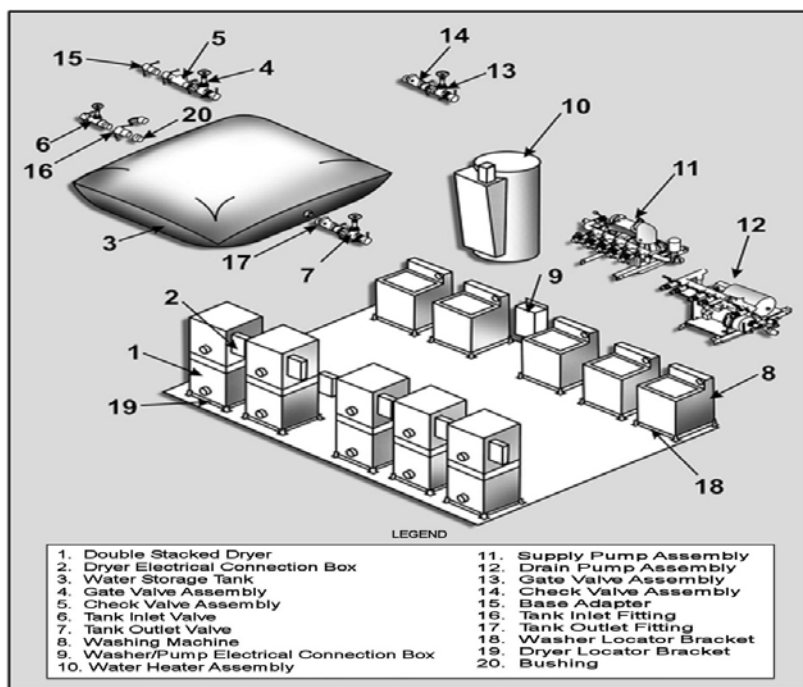

Chapter 4

MOBILE ELECTRIC POWER AND DISTRIBUTION

4.1. General Information. Mobile electric power (MEP) generation and distribution is an important part of any bare base deployment operation (**Figure 4.1.**). BEAR power generating systems consists of both prime power and tactical quiet generators (TQG).

4.1.1. Individual or synchronized prime generators in a power plant provide high-voltage power to the BEAR electrical distribution systems. Although newer, more efficient prime power generators are being pursued, the MEP-012A continues to provide great service and is in widespread use around the globe. TQGs are lightweight, portable, diesel engine-driven generators that are fully enclosed, reliable, and quiet. These critical assets provide initial power before a primary power plant and distribution system are constructed. Afterwards, they provide backup power or power for remote facilities. BEAR TQGs include the MEP-805B and MEP-806B generator.

4.1.2. The amount of electrical power required during a given deployment depends on the mission and population at that particular location. This chapter addresses current bare base power generation and distribution systems as well as older, legacy assets that may still be in use.

Figure 4.1. Establishing Deployed Power Plant.



4.2. MEP-805B TQG. The MEP-805B (**Figure 4.2.**) provides tactical quiet AC power and is easily transported, operated and maintained. It connects to the Secondary Distribution Center (SDC) and produces 104-amps/30 kW at full load. See **Table 4.1.** for basic characteristics and consult T.O. 35C2-3-446-32 *Generator Set, Skid Mounted, Tactical Quiet, MEP-805B 30KW 50/60 Hz*, for operating and maintenance information.

Figure 4.2. MEP-805B Generator.



Table 4.1. MEP-805B Generator Characteristics.

Dimensions LWH (in)	79.7" x 35.7" x 55"
Dry Weight*	2732 lbs
Wet Weight	2931 lbs
Fuel Type	DF-1, DF-2, DF-A, JP-5, JP-8
Fuel Tank Capacity	23 gallons
Fuel Consumption Rate	2.60 gallons/hour
Load Capacity	30kW
Current Rating (120/208 V)	60 Hz, 104 amps / 50 Hz, 86 amps
Current Rating (240/416V)	60 Hz, 52 amps / 50 Hz, 43 amps
Other	Remote Control Capable

4.3. MEP-806B TQG. The MEP-806B (**Figure 4.3.**) also provides tactical quiet AC power. However, it produces 208-amps/60 kW at full load. Like the MEP-805B, it connects to the SDC and is easily transported, operated and maintained. See **Table 4.2.** for basic characteristics and consult T.O. 35C2-3-444-32, *Generator Set, Skid Mounted, Tactical Quiet, MEP-806B, 60KW, 50/60 Hz*, for information on operating and maintaining this generator.

Figure 4.3. MEP-806B Generator.



Table 4.2. MEP-806B Generator Characteristics.

Dimensions LWH (in)	87" x 35.7" x 59"
Dry Weight*	3556 lbs
Wet Weight	3992 lbs
Fuel Type	DF-1, DF-2, DF-A, JP-5, JP-8
Fuel Tank Capacity	43 gallons
Fuel Consumption Rate	5.06 gallons/hour
Load Capacity	60kW
Current Rating (120/208 V)	60Hz, 208 amps / 50 Hz, 173 amps
Current Rating (240/416V)	60 Hz, 104 amps / 50 Hz, 86 amps

4.4. MEP-012A Prime Power Generator. A wheel-mounted, diesel engine-driven generator that can produce 750 kilowatts of prime power (**Figure 4.4.**). It has a liquid cooled, turbocharged, V12 diesel engine and a three phase, four wire, wye connected alternator and is capable of remote operation up to 150 feet from the generator. See **Table 4.3.** for basic characteristics and consult T.O. 35C2-3-474-1, *Generator Set, Diesel Engine-Drive, Wheel-Mounted 750-KW*, for operating and maintenance information.

Figure 4.4. MEP-012A Generator.



Table 4.3. MEP-012A Generator Basic Characteristics.

Dimensions LWH (in)	241" x 96" x 101" (without mufflers)
Weight	24,500 lbs (dry) / 25,373.6 lbs (wet)
Fuel Type	DF-1, DF-2, DF-A, JP-5, JP-8
Fuel Tank Capacity	42 gallons
Fuel Consumption Rate	55 gallons/hour
Voltage Output at 60Hz:	750kW, 2400/4160 volts. 3 phase. 4 wire
Voltage Output at 50Hz:	635kW, 2200/3800 volts. 3 phase. 4 wire
Other	Remote Control Operation Capable

4.5. Interim Power Unit (IPU). The IPU supplements BEAR high power systems and have a prime power rating of 1100kW. It consists of a generator set housed inside a 40-foot ISO container mounted on a 40-foot trailer (**Figure 4.5.**). The unit has sound-reduction features, and contains switchgear, battery and starter components, shore power components, and a 300-gallon fuel tank. It has remote control capability and weighs approximately 52,000 pounds. See **Table 4.4.** for basic characteristics.

Figure 4.5. Interim Power Unit.



Table 4.4. IPU Basic Characteristics.

Generator Set	Cummins Model DQGAA
Weight	51,800 lbs (Generator/ISO/Trailer)
Prime Power	1100kW
Standby Rating	1250kW
Fuel Type	Diesel
Voltage Output at 60Hz:	2400/4160 volts. 3 phase. 4 wire
Other	Remote Control Operation Capable

4.6. Generator Fuel Bladders. Collapsible, coated fabric fuel bladders are often used as an auxiliary fuel source for MEP generators (**Figure 4.6.**). This is especially true for high fuel-consumption prime power generators. The 10,000-gallon bladder is most often used as the auxiliary fuel source for MEP-012A generators. When filled, the bladder assumes a “pillow” like shape. When not filled, the fuel bladder can be folded, rolled, and stored after cleaning. A 20-foot-by-20-foot, 10,000-gallon bladder will support two MEP-12s for about 4-5 days. See Chapter 7 for additional information on this and other non-BEAR fuel bladders.

Figure 4.6. Collapsible Fuel Bladder.



4.7. Electrical Distribution Systems. The primary components of the BEAR electrical distribution system consists of power switching and distribution centers, distribution panels, and associated cables and connectors. For additional information see AFH 10-222, Volumes 5, *Guide to Contingency Electrical Power System Installation*; AFPAM 10-219, Volume 5, *Bare Base Conceptual Planning Guide*; and applicable technical orders.

4.7.1. Primary Switching Center (PSC). The DRS Radian Model PSC (**Figure 4.7.**) is a high-voltage switching station that receives 4,160 volt, 3-phase electric power from BEAR power units or commercial means through two high voltage load interrupting switch inputs. The PSC has four feeder circuits; each circuit is capable of feeding multiple secondary distribution centers (dependent on PSC power source and individual secondary distribution center load). It can also be connected to other PSCs through one of the high voltage fault interrupting switches, reducing outputs to three from each PSC. See **Table 4.5.** for additional characteristics and consult T.O. 35F14-1-1, *Deployable Power Generation and Distribution System (DPGDS) for a Primary Switch (PS)*, for PSC operation and maintenance information.

Figure 4.7. Primary Switching Center (DRS Radian Model).



Table 4.5. PSC Characteristics.

Dimensions LWH (in)	104" x 72" x 48"
Weight	4,000 lbs
Rating at 60 Hz	600 amps / 15,500 Volts (15.5kV)
Rating at 50 Hz	630 amps / 12,000 Volts (12kV)

4.7.2. **Secondary Distribution Center (SDC).** The SDC accepts primary power and reduces the voltage for distribution to outlet receptacles and on to facilities or equipment (**Figure 4.8.**). Primary power is provided by either commercial power plants, engine driven prime power generator sets or another SDC. If required, the primary input and transformer can be bypassed, so an SDC can be fed from a low-voltage generator and used only as a distribution center. **Table 4.6.** lists additional characteristics. See T.O. 35CA2-2-17-1, *Operation and Maintenance Manual, Secondary Distribution Center (SDC) 150 KVA (DPGDS)*, for more technical information.

Figure 4.8. Secondary Distribution Center (Radian Model).



Table 4.6. SDC Characteristics.

Dimensions LWH (in)	60.56" x 47.63" x 71.88" (76.16" w/lift rings)
Weight	2,070 lbs
Input	4160 VAC/3-Phase/60Hz 3810 VAC/3-Phase/50Hz
Output	208 Y / 120 VAC/3-Phase 60 or 50Hz 3-wire 208 Y / 120 VAC/3-Phase 60 or 50Hz 4-wire

4.7.3. **25kW Power Distribution Panel (PDP).** The 25kW PDP (Radian Model) is designed to distribute 1- and 3-phase low voltage electrical power to various BEAR facilities and equipment from a 120/208 VAC power source such as a SDC or TQG (**Figure 4.9.**). It has multiple power output connections ranging from 15 Amps to 60 Amps. The 60-Amp, 3-Phase output can be used to power assets like the ECU. See **Table 4.7.** for other basic characteristics and consult T.O.35CA6-1-211, *Power Distribution Panel (PDP), 25KW*, for other technical information.

Figure 4.9. 25kW Power Distribution Panel (Radian Model).



Table 4.7. PDP Characteristics (25kW).

Dimensions LWH (in)	22" x 18" x 18"
Weight	38 lbs
Input	One 60 Amp, 120/208 VAC, 3-Phase
Output	One 60 Amp, 120/208 VAC, 3-Phase Four 20 Amp, 120 VAC, 1-Phase One 15 Amp, 120 VAC, 1-Phase

4.7.4. **60kW Power Distribution Panel (PDP).** The 60kW PDP is designed to facilitate the safe and orderly distribution of electric power in an outdoor field environment (**Figure 4.10.**). It distributes 120/208V, 200-Amp, 3-Phase power to four 120/208V, 60-Amp, 3-Phase circuits. See **Table 4.8.** for additional characteristics and consult T.O. 35A6-1-231, *Power Distribution Panel (PDP) 60KW*, for other technical information.

Figure 4.10. 60kW Power Distribution Panel (Radian Model).



Table 4.8. PDP Characteristics (60kW).

Dimensions LWH (in)	28" x 21" x 18"
Weight	38 lbs
Input	One 200-Amp, 120/208 VAC, 3-Phase
Output	Four 60-Amp, 120/208 VAC, 3-Phase

4.7.5. Power Cables and Connectors. Electrical power distribution cables and connectors are generally divided into two categories, primary and secondary cables.

4.7.5.1. Primary Cable. Primary electrical distribution cables (#1/0 5-kV insulated aluminum wire) are used for high-voltage runs between generators, PDCs and SDCs. One cable is used for each of the three phases; it comes on a pallet with three 3,000-foot cable reels mounted side-by-side (**Figure 4.11.**).

4.7.5.2. Secondary Cable. Secondary electrical power distribution cables are 3-phase insulated cable, in pre-assembled lengths with cannon plug connectors at each end (**Figure 4.12.**). The 25-foot long, 200-amp cables are used to connect portable generators with SDCs. The 60-amp cable, either 50 feet or 100 feet long, connect SDCs and individual facility PDPs. Secondary cable runs should be limited to 150 feet to conserve cable and minimize voltage drop, but runs of up to 800 feet are acceptable when there is no practical alternative. Listed in **Table 4.9.** are approximate voltage drops at rated amperage and cable length. However, actual voltage drop will be affected by temperature and the quality of the connection made when mating the connectors (dirt, corrosion, and oil affect pin resistance).

Figure 4.11. Primary Electrical Distribution Cable and Reel.



Figure 4.12. Typical Secondary Electrical Distribution Cables.

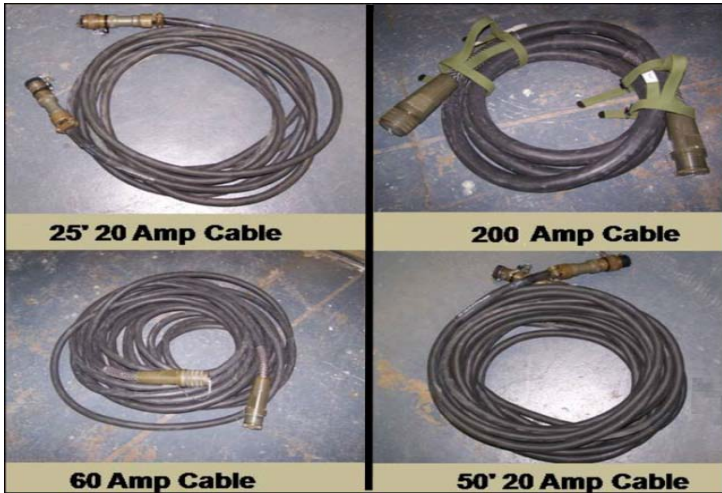

Table 4.9. Approximate Voltage Drops.

Rated Amperage/Pins	Cable Length and Approximate Voltage Drop					
	15 ft	25 ft	50 ft	100 ft	200 ft	300 ft
200 amp/8 pin cables (3-ph)	1V	1.6V	3.2V	6.4V	12.8V	19.2V
100 amp/8 pin cables (3-ph)	0.4V	0.7V	1.4V	2.8V	5.6V	8.4V
60 amp/5 pin cables (3-ph)	0.5V	0.9V	1.6V	3.5V	6.4V	10.5V
40 amp/5 pin cables (3-ph)	0.3V	0.6V	1.1V	2.3V	4.4V	6.9V
60 amp/4 pin cables (1-ph)	0.5V	0.9V	1.7V	3.4V	6.8V	10.2V
20 amp/3 pin cables (1-ph)	1.1V	1.8V	3.6V	7.2V	14.4V	21.6V

4.8. Legacy Power Systems. Older, legacy model generators and power distribution systems help bridge the gap as newer, more efficient systems are brought into the BEAR inventory. This section addresses some of the BEAR legacy power systems still in operational service.

4.8.1. MEP Generators. Currently, a few older model generators are still in use in the Area of Responsibility (AOR). Although not a complete list, some of these legacy generators and their characteristics are listed in **Table 4.10**.

Table 4.10. Characteristics of Legacy Generators.

	MEP-005A	MEP-006	MEP-007
Dimensions LWH (in)	80" X 36" X 55"	87" x 36" x 59"	106" x 40" x 65"
Dry Weight*	2,850 lbs	4,240 lbs	6,680
Fuel Type	DF-1, DF-2, DF-A, JP-5, JP-8	DF-1, DF-2, DF-A, JP-5, JP-8	DF-1, DF-2, DF-A, JP-5, JP-8
Fuel Tank Capacity	26 gallon	55 gallons	91 gallons
Fuel Consumption Rate	3 gallons/hour	6 gallons/hour	8.5 gallons/hour
Load Capacity	30kW at 60Hz 25kW at 50Hz	60kW at 60Hz 50kW at 50Hz	100kW at 60Hz 83.3kW at 50Hz
Output	120/208V 240/416V	120/208V 240/416V	120/208V 240/416V
Connection	3 phase, 4 wire	3 phase, 4 wire	3 phase, 4 wire
* Dry weight = less Basic Issue Items List			

NOTE

All MEP generators (TQGs and Prime Power) including legacy models, can be configured to produce either 50 or 60 Hz, but is de-rated to 80-85 percent of their nominal generating capacity at 50 Hz.

4.8.2. **Secondary Distribution Center (Model JEU-191/E).** Similar to the Radian Model SDC addressed in **paragraph 4.6.2**, the legacy JEU-191/E SDC (**Figure 4.13.**) receives and transforms power for distribution to bare base facilities. In addition to design differences, this legacy unit is also larger and heavier than the current BEAR SDC. See **Table 4.11.** for basic design characteristics and T.O. 35CA2-2-10-1, *Secondary Distribution Center (JEU-191/E)*, for operation and maintenance instructions.

Figure 4.13. Secondary Distribution Center (Model JEU-191E).



Table 4.11. SDC Characteristics (Model JEU-191E).

Dimensions LWH (in)	81" x 48" x 77"
Weight	3,340 lbs
Input	4160 VAC, 3 phase, 60 HZ
Output	120/208 VAC, 3 phase, 60 HZ



Chapter 5

HEATING, VENTILATION, AIR CONDITIONING, AND REFRIGERATION (HVAC/R)

5.1. General Information. Heating, cooling, and ventilation systems are an integral part of BEAR equipment sets. There are several HVAC/R systems fielded (including current and legacy systems); however, through attrition and ongoing equipment modernization, many of the older systems are being replaced with systems that are more versatile. This chapter will address primary and legacy systems still in use. Refer to AFH 10-222, Volume 12, *Guide To Bare Base Mechanical Systems*, and applicable technical data for guidance on the installation, operation, and maintenance of these systems.

5.2. Field-Deployable Environmental Control Unit (FDECU). The FDECU is the primary BEAR ECU (**Figure 5.1**). There are several different models fielded and each can be used to heat, cool, dehumidify, filter and circulate air in portable shelters and containers for personnel and equipment. If desired, the units can also admit fresh, outside air inside the shelter by adjusting the return air duct and flange. See **Table 5.1** for basic characteristics and consult T.O. 35E9-314-1, *Field-Deployable Environmental Control Unit* (Models FDECU-2, FDECU-3, FDECU-4, FDECU-5, & FDECU-9), for operating and maintenance instructions.

Figure 5.1. FDECU.



Table 5.1. FDECU Characteristics.

Dimensions LWH (in)	42" x 52" x 32.5"
Max. Weight (FDECU-2 and -3 only)	800 lbs
Max. Weight (FDECU-4 and after)	700 lbs
Cooling Capacity (BTU/Hour)	Minimum: 55,000 Maximum: 67,000
Heating Capacity (BTU/Hour)	Minimum: 47,000 Maximum: 84,000
Refrigerant Type	R-134a
Refrigerant Charge	14 lbs
Voltage Requirements	208 VAC (191 to 218) 50/60Hz, 3 Phase
Max. Wattage Ventilation Mode: Cooling Mode: Heating Mode:	1.5 kW 14.0 kW 13.5 kW
Total Airflow	2300 SCFM
Makeup Airflow	0 to 500 SCFM (adjustable)
Environmental Limits—Operational Temperature Range (Cooling): Temperature Range (Heating): Altitude Range (Feet):	50° F to 135° F -25° F to 75° F 6,000

5.3. 130K Portable Heater. Provides heated air for sleeping quarters and work facilities (**Figure 5.2.**). This multi-fueled heater will deliver hot air at a minimum of 1000 cubic feet per minute and at temperatures ranging from 80° F to 180° F—making it ideal for extremely cold conditions. It can also provide forced fresh air ventilation without heating. **Table 5.2.** lists additional characteristics. Consult AFH-10-222, Volume 12, and T.O. 35E7-3-4-1, *Heater, 130K Multi-Fueled, Portable, Duct Type 130,000 BTUH Model Polar Bear1*, for installation, operation, and maintenance instructions.

Figure 5.2. 130K Portable Heater.**Table 5.2. 130K Portable Heater Characteristics.**

Dimensions LWH (in)	47" x 29" x 34"
Weight (empty)	275 lbs
Heated Air Temperature Range (average)	High (120 – 180° F) Medium (100 – 160° F) Low (80 – 140° F)
Voltage Requirement	120 Volts 50/60Hz
Fuel Tank Capacity	21 gallons
Operating Time Without Refueling	15 hours @ -25° F ambient (on High setting attached to tent)
Fuels	DL-1, DL-2, Jet A, Jet A1, JP4, JP-5, JP-8, and JP-8+100

5.4. H-1 Heater Unit. Produces fresh uncontaminated heated air for aircraft engines and fuselages, ground vehicles, maintenance buildings, field shelters, and temporary structures. The H-1 Heater (**Figure 5.3.**) can also be used for forced air ventilation without heating. See **Table 5.3.** for additional characteristics and consult T.O. 35E7-2-11-11, *Heater H-1 Diesel Fueled, Portable, Duct Type 4000,000 BTU/H*, for operation and maintenance information.

Figure 5.3. H-1 Heater.



Table 5.3. H-1 Heater Characteristics.

Dimensions LWH (in)	68.5" x 44" x 51.5"
Weight (empty)	800 lbs
Heated Air Temperature Range	Maximum: 280° F Minimum: 150° F
Heated Air Output (BTU/Hour) Model BT 400-46	Maximum: 400,000 (-65° F ambient) Minimum 100,000 (70° F ambient)
Fuel Tank Capacity	35 gallons
Operating Time Without Refueling	15 hours @ -25° F ambient (on High setting attached to tent)
Fuel Types	JP4, JP-5, JP-8, JP-8, Fed. Spec. VV-F-800, DF-1 and DF-A

5.5. M-80 Water Heater. Primary boiler and water heater for BEAR facilities requiring hot water, such as shower and shave units, kitchens, laundries, and medical facilities. The M-80 water heater (**Figure 5.4.**), operates on diesel fuel (primary) or gasoline (secondary) and requires 208V electric power. It maintains water temperature in the 160° F to 190° F range, with a capacity of approximately 24 gallons. Additional characteristics are listed in **Table 5.4.** Refer to T.O. 35E7-4-27-1, *Heater, Water, Liquid Fuel*, for operation and maintenance information.

Figure 5.4. M-80 Water Heater.



Table 5.4. M-80 Water Heater Characteristics.

Dimensions LWH (in)	52" x 27" x 47"
Weight	465 lbs
Electrical Input	208 VAC, 3-Phase
Water Vessel Capacity	23.7 gallons
Water Delivery Capacity	9 gallons per minute (approx.)
Fuel Types	DF-A, DF-1, DF-2, VV-F-800, JP-4, JP-5, JP-8, and Commercial Fuel No. 2

5.6. WH-400 Water Heater. The WH-400 (**Figure 5.5.**) will enter the BEAR inventory as a replacement for the M-80 on an attrition basis. Like the M-80, it is a fuel-fired, skid-mounted water heater that delivers water at a rate of 9 gpm. Heater characteristics are listed in **Table 5.5.** Refer to TM 10-4520-266-13&P, *Heater, Water, 4000,000 BTU*, for operation and maintenance information.

Figure 5.5. WH-400 Water Heater.



Table 5.5. WH-400 Water Heater Characteristics.

Dimensions LWH (in)	55" x 32" x 74" (operating configuration)
Weight	500 lbs
Electrical System	208 VAC, 3-Phase/120 VAC, Single Phase
Water Vessel Capacity	27.1 gallons
Water Delivery Capacity	9 gpm between 60° F and 190° F
Primary Fuel	JP-8
Alternate Fuel Types	DF-A, DF-1, DF-2, and JP-5
Fuel Consumption	3.5 gph (13.2 lph)

5.7. Advanced Design Refrigerator, 300 Cubic Foot (ADR-300). The ADR-300 is the primary BEAR refrigeration system (**Figure 5.6.**) and provides refrigerated storage for a wide variety of items and commodities. The ADR-300 consists of two main sub-systems, the insulated container (IC) and the refrigeration unit (RU). The IC is an insulated box constructed of foam-filled, fiberglass panels mounted on an aluminum skid. The RU maintains the interior temperature of the IC and consists of the refrigerator and unit controller. See **Table 5.6.** for additional ADR-300 characteristics. For operation and maintenance information, consult T.O. 40R7-6-1, *Advanced Design Refrigerator, 300 Cubic Foot (ADR-300)*.

Figure 5.6. ADR-300.



Table 5.6. ADR-300 Characteristics.

Exterior Dimensions LWH (in)	108" x 88" x 96"
Interior Volume	281 cubic feet
Empty Weight	3,285 lbs
Max. Payload	6,715 lbs
Electrical Power	208/230 VAC, 3-phase, 50-60 Hz
Refrigerant Charge and Type	4.62 lb, R-404A

5.8. TRICON Refrigerated Container System (TRCS). The TRCS will be fielded as a replacement for the ADR-300 refrigeration system in surface-configured BOB UTCs. The ADR-300 will remain in the air UTCs and be replaced with the TRCS through attrition. The TRCS is made up of two principle components, a triple container (TriCon) and an integrated refrigeration/freezing/heating unit (referred to as "RU"). It is designed to be coupled to other TRCS and/or dry freight TriCons using eight approved interconnectors (NSN 3040-01-387-4048 or equivalent). When three TRCS and/or dry freight TriCons are coupled, the dimensions, tolerances, and diagonal differences are equivalent to specifications of a 20-foot insulated container. A typical TRCS is illustrated in **Figure 5.7**. See **Table 5.7**. for additional TRCS characteristics.

Figure 5.7. TRICON Refrigerated Container System.



Table 5.7. TRCS Characteristics.

Exterior Dimensions LWH (in)	77.5" x 96" x 96"
Interior Volume	281.6 cubic feet
Empty Weight	3,520 lbs
Max. Payload	11,480 lbs
Electrical Power	208/230 VAC, 3-phase, 50-60 Hz

5.9. Legacy HVAC/R Systems.

5.9.1. **ECU-39.** The Dash 39 (**Figure 5.8.**) was in widespread use until the FDECU became the primary ECU in the BEAR inventory. Some units may still be in service today. They are used to heat, cool, dehumidify, filter and circulate air in portable shelters and vans to meet the controlled environmental requirements of personnel and electronic equipment. The unit can be adjusted to admit fresh air at a controlled rate. Typically, the unit is located external to the controlled space and the conditioned air circulates through supply and return ducts. Approximate cooling capacity is 4.5 tons. Approximate heating capacity is 9.6 kilowatts (down to approximately 30° F). This unit uses R-22, an ozone-depleting refrigerant.

Figure 5.8. ECU-39.

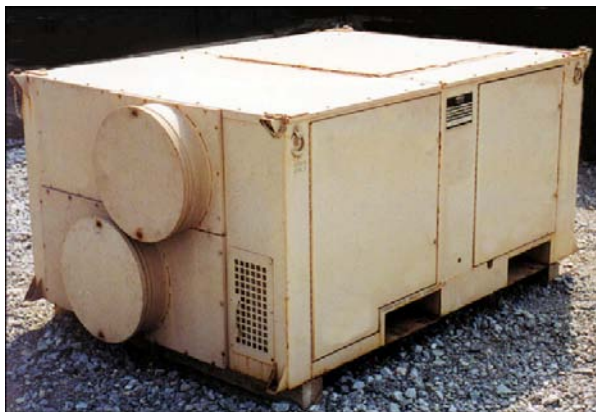

5.9.2. **1200-Cubic Foot (CF) Refrigerator.** This is a large refrigeration unit assembled on site from insulating panels, with a separate 18,000 BTUH refrigeration unit (**Figure 5.9.**). It supports food service operations and is approximately 13 feet wide, 17 feet long and 8 feet high. The unit requires at least 6 feet of clear space on the ends to allow for installation and ventilation of the condensers.

Figure 5.9. 1200-CF Refrigeration Unit.



5.9.3. **150-CF Refrigerator.** The 150-CF refrigeration unit (**Figure 5.10.**) is a one-piece field refrigeration box with a single door in front and a rear-mounted 5,000 BTUH direct-expansion (DX) refrigeration unit. It is used for food service, mortuary and medical applications. It is approximately 7 ft x 7 ft x 7 ft over-all.

Figure 5.10. 150-CF Refrigeration Unit.

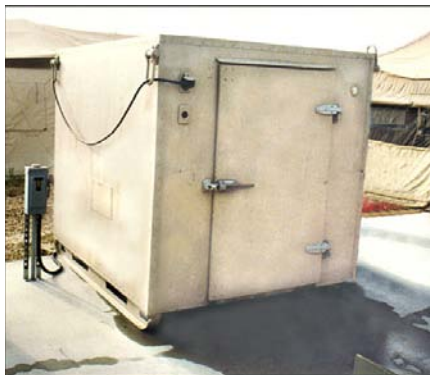

Chapter 6

SPECIALIZED ASSETS

6.1. General Information. Although specialized equipment items may be tasked individually, they are often packaged with shelters or deployed within various BEAR industrial operations and support packages. The following paragraphs provide a brief description of these specialized assets.

6.2. Specialized Equipment and Systems.

6.2.1. Remote Area Lighting System (RALS). Used for general lighting along the flightline, around petroleum, oil and lubricant (POL), liquid oxygen (LOX) plants, etc. It contains 13 telescopic two-lamp light poles, four 375-foot cable sets and an aluminum container/control box (**Figure 6.1.**). One light pole connects to the control box and the others every 125 feet along the cable sets. The RALS requires an outside power source, such as a generator or feed from a SDC.

Figure 6.1. Remote Area Lighting System (RALS).



6.2.2. TF-2 Light Cart. The TF-2 floodlight is used primarily for initial camp beddown, perimeter lighting and flightline use. It is a self-contained, mobile, power generating light source with a manually operated boom and an onboard generator. Capable of illuminating large work sites while providing 6 kW of electricity at 120 VAC (**Figure 6.2.**).

Figure 6.2. TF-2 Light Cart.

6.2.3. **AM-2 Aluminum Mats.** These are two-inch thick interlocking aluminum panels normally used for aircraft parking ramps or pads, taxiways and hangar floors ((**Figure 6.3.**)). However, AM-2 contained in BEAR UTCs is currently utilized for flooring in BEAR shelters and not for flightline operations. Individual sections are 2 feet wide, and either 6 feet or 12 feet long. AM-2 is typically shipped in bundles, each of which contains 4 short and 16 long sections, and will cover 432 square feet. For additional information, see T.O. 35E2-2-7, *AM-2 Airfield Landing Mat and Accessories*.

Figure 6.3 Laying AM-2 Matting at Deployed Location.

6.2.4. **Concertina Wire.** This wire provides a personnel barrier for internal areas of the base, such as industrial and flightline operations or other critical, high value facilities, areas or infrastructure. Concertina wire packages consist of 480 rolls of barrier wire (50 feet per roll) providing 8,000 linear feet of coverage (**Figure 6.4.**). This quantity of wire is not designed to provide perimeter barriers around an entire austere base.

Figure 6.4. Moving Heavy Rolls of Concertina Wire.



6.2.5. **Air Compressors.** Provides compressed air for hangars, garages, paint shops, pneumatic tools, greasing equipment, tire inflation and other equipment. Models include the electric-powered MB-8 (200 psi) and the diesel-driven MC-5 (100 psi) and MC-2A (200 psi). **Figure 6.5.** is the MC-2A model

Figure 6.5. MC-2A Diesel-Driven Air Compressor.



6.2.6. Camouflage Nets and Poles. BEAR camouflage sets includes 200 desert-colored, lightweight radar scattering nets and 70 support systems to provide camouflage screening and shade for facilities and equipment. Each net is capable of covering approximately 200 square feet and the set can be configured to cover single or multiple structures.

6.2.7. Emergency Airfield Lighting System (EALS). The EALS is a runway lighting system designed to be rapidly installed at contingency airfields or at other locations that need temporary airfield lighting (**Figure 6.6.**). It contains a complete lighting kit for runways up to 10,000 feet long and 150 feet wide. When installed, it provides runway edge lighting, approach lighting, threshold/end lighting, taxiway lighting, visual glide slope indication, Distance-To-Go (DTG) marker lighting, and obstruction lighting. The system supports contingency operations at night and during periods of reduced visibility. The EALS is packaged on six mobile trailers and includes generators, cables, control panels, transformers and regulators. Under ideal conditions, a six-person crew using two general-purpose vehicles (e.g., 3/4 ton pickup, 1 ton, 1-1/2 ton trucks, etc.) can install a 50-foot by 5,000-foot minimum operating strip (MOS) in about 2.5 hours. Additional time is needed to securely mount and properly adjust precision approach path indicator (PAPI) lights, and to anchor edge lights against jet blast from large aircraft. Refer to AFH 10-222, Volume 7 and T.O. 35F5-3-17-1, *Lighting System, Airfield, Emergency, A/E82U-2*, for detailed guidance on installation and operation.

Figure 6.6. EALS Temporary Airfield Lights.

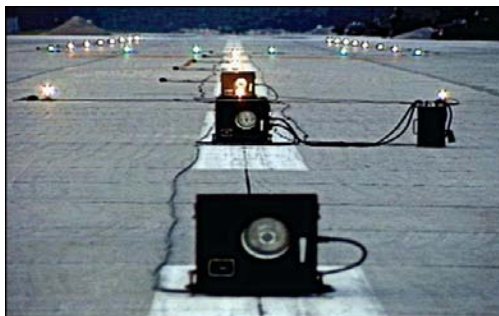

6.2.8. Expeditionary Airfield Lighting System (EALS II). The new EALS II system is designed as a replacement for the current EALS. The new modular system supports day and night operations and is night vision goggle (NVG) compatible. It uses light emitting diode (LED) technology and is battery powered with solar recharge or hardwired to a generator or commercial power.

Table 6.1. highlights the four modules of the EALS II.

Table 6.1. EALS II Modules.

Expeditionary Airfield Lighting System II	
Module 1	90' X 5000' landing zone
Module 2	Unidirectional 150' X 5000' runway, approach lights on one end
Module 3	Expands Module 2 in 2,500' increments out to 15,000'
Module 4	Second approach light set for bi-directional operations

6.2.9. A/M 32A-96 Mobile Aircraft Arresting System (MAAS). The MAAS is an air and surface transportable, rapid installation emergency aircraft arresting system. It is a rotary friction-type energy absorber consisting of two identical units installed on each side of the runway. Each unit houses one BAK-12 rotary friction energy absorber. The BAK-12 aircraft arresting gear mounted on mobile trailers is for use with most fighters (**Figure 6.7.**). In its simplest configuration, the MAAS is unidirectional and can be rapidly moved and anchored adjacent to the runway on soil, asphalt or concrete by a crew of 6 personnel in approximately two hours. An upgrade kit (longer nylon tapes and lightweight fairlead beams, or mobile runway edge sheaves) allows the MAAS trailer units to be set back from the runway edge. This eliminates wingtip clearance concerns for large aircraft while providing bi-directional engagement capability. Refer to T.O. 3538-2-10-1, *Arresting Systems, Aircraft, Mobile*, and AFH 10-222, Volume 8, for detailed guidance on installation and operation.

Figure 6.7. Mobile Aircraft Arresting System.

6.2.9. Single Pallet Expeditionary Kitchen (SPEK). The SPEK (**Figure 6.8.**) is a complete food service facility capable of providing hot meals to 500 personnel at a time. Once deployed the SPEK can be unpacked and assembled in one and one half hours. An additional two and one half hours are required to prepare a meal for 300 persons, using Utilized Group Rations-Heat and Serve (UGR-H & S). The SPEK can be deployed by air or ground transportation, and requires a minimum of 4 personnel to unpack, assemble, operate, and repack. The SPEK does not require outside power, having a 2KW Military Tactical Generator Set; however, all components operate on 120 VAC 50/60 Hz power, and can be powered by available local utilities or generators. Once set up the SPEK requires only potable water, fuel, rations, and water disposal. Refer to T.O. 35E4-235-1, *Single Pallet Expeditionary Kitchen* for detailed guidance on installation and operation.

Figure 6.8. Single Pallet Expeditionary Kitchen (SPEK).

6.2.10. **BEAR 550 Kitchen.** The BEAR 550 kitchen ([Figure 6.9.](#)) is a complete portable food preparation and serving complex. It is designed to serve up to 550 personnel and seat 120. That capacity is doubled (1100 personnel and 240 seats) when kitchens are combined. All tools, components and equipment, (except electrical and water supplies), that are required to unpack, set up, operate, maintain, strike, and repack the facility, are supplied in the shipping containers. Force Support personnel normally erect all tents associated with the kitchen; however, engineers provide supporting utility service (power, water and wastewater) and install some of the more complicated equipment items such as water heaters, walk-in refrigeration units and air conditioning units. The power distribution system takes electrical power from an external source and steps it down to the power level requirements of the various electric appliances and lights. The major components of the kitchen's power distribution system include secondary distribution boxes, cable assemblies and lighting harnesses. Electrical power requirements are one 225-Amp, 208 VAC, 3 Phase, 60 Hz power source and two 150-KVA secondary distribution centers. The Advance Design Refrigerator (ADR) requires 208/230 VAC 60 HZ. Refer to Work Package (WP)-005 00, T.O. 35E4-169-31, *BEAR Base Harvest Falcon/Eagle Electric Kitchen with Mess Kit Laundry*, for more information on siting kitchen facilities.

Figure 6.9. BEAR 550 Kitchen (550-Personnel).

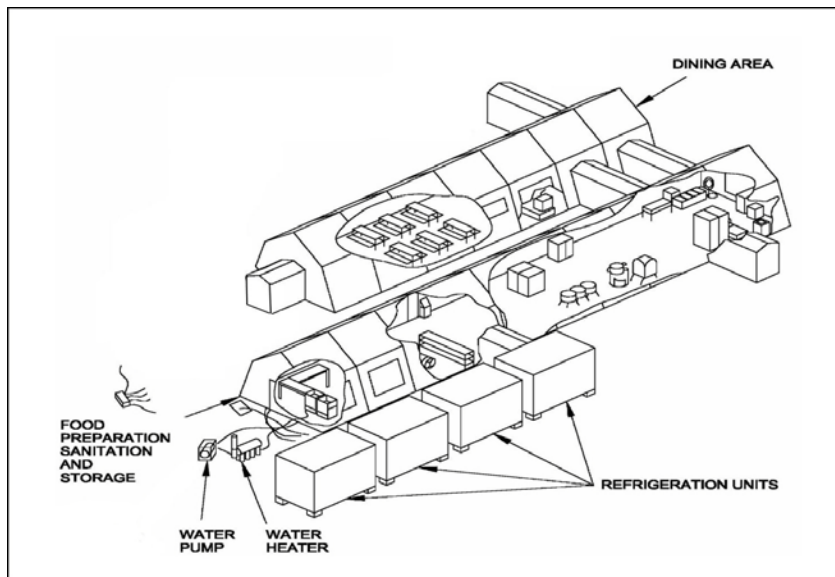

Chapter 7

NON-BEAR ASSETS

7.1. General Information. In addition to BEAR assets, many other expeditionary equipment packages are required to support Air Force bare base operations. The owning functional area organizations deploy, set up and operate the assets, but typically require civil engineer support for siting, site preparation and utility service. Engineers must work with representatives from the other functional areas to ensure optimum use of such packages.

7.2. Fuels Operational Readiness Capability Equipment (FORCE). A mobile, air-transportable, aircraft and ground fuel delivery system that is designed to replace older and less efficient Fuels Mobility Support Equipment (FMSE). FORCE consists of a Trailer-Mounted Pumping Unit (R-18), a Trailer-Mounted Filter Separator (R-19), a Multi-Aircraft Servicing Platform (R-20) and a Plumbing Assembly (R-21). The full capability mission of the complete FORCE System, when used in conjunction with fabric fuel bladders, provides a deployable, above-ground, constant pressure, flow-on demand fueling system for aircraft, i.e., a hydrant-type fueling system. Currently being fielded at numerous locations, FORCE fueling systems saves time and resources, and improves safety, reliability, and flexibility of the deployed fueling systems.

7.2.1. R-18 Trailer-Mounted Pumping Unit. A trailer-mounted self-priming, air-eliminating pump (**Figure 7.1.**), offloads trucks at the base perimeter, delivers fuel through 6-inch hose lines to interim storage systems and provides fuel flow at 900 gpm/150 psi at a distance of 10,000 feet to the R-20 Multi-Aircraft Servicing Platform.

7.2.2. R-19 Trailer-Mounted Filter Separator. Designed to filter and separate particulate and water from fuel, the trailer-mounted R-19 (**Figure 7.2.**) weighs about 3,000 pounds and consists of two 600-gpm aluminum alloy filter separators. The separators are configured to run in parallel at 1200 gpm or individually at 600 gpm.

Figure 7.1. R-18 Trailer-Mounted Pumping Unit.



Figure 7.2. R-19 Trailer-Mounted Filter Separator.



7.2.3. R-20 Multi-Aircraft Servicing Platform. The R-20 Multi-Aircraft Servicing Platform (**Figure 7.3.**) is the interface between one or two receiver aircraft. It has a combined fueling capability of 900 gpm through two 2.5-inch, 60 foot semi-collapsible servicing hoses (450 gpm through each hose). The R-20 is a trailer-mounted servicing platform and weighs about 4,600 lbs. It is air-transportable.

Figure 7.3. R-20 Multi-Aircraft Servicing Platform.



7.2.4. R-21 Portable Hydrant Mission Support Plumbing Assembly. The R-21 plumbing assembly (**Figure 7.4.**) consists of all hoses, valves, adapters, couplings, and evacuation equipment necessary to connect the various components of the FORCE receipt, transfer, storage, filtration and issue systems. The plumbing assembly is packed in Tricon containers and is air transportable.

7.2.5. Tactical Automated Service Station. The TASS (**Figure 7.5.**) is a trailer-mounted automated ground fuel issue point for vehicles and support equipment at deployed locations. It is capable of delivering DF-2, JP-8 and MOGAS at a minimum rate of ten gallons per minute (10 GPM) through each dispensing nozzle. The TASS provides an interface between bulk fuel transport trailers or other fuel sources and vehicles/support equipment requiring ground fuel.

Figure 7.4. R-21 Portable Hydrant Mission Support Plumbing Assy.



Figure 7.5. Tactical Automated Service Station (TASS).



7.3. Fuels Mobility Support Equipment (FMSE). While newer FORCE systems are being fielded, many FMSE assets still remain in service. FMSE assets are used to receive and issue fuel at bare bases and to augment locations with fixed-fuel facilities. Examples include the R-14 Air-Transportable Hydrant Refueling System (ATHRS), the R-22 Trailer Mounted Transfer Pump, and the FFU-15E Skid-Mounted Filter Separator.

7.3.1. R-14 Air Transportable Hydrant Refueling System. The complete R-14 system contains three identical self-sufficient modules. Each module consists of a diesel powered 600-gpm pump and filter separator, mounted on a four-wheeled trailer, with associated valves, hoses, adapters, meter and two 50,000-gallon bladders (**Figure 7.6.**). Each R-14 module can refuel or defuel one heavy aircraft at 600 gpm or two fighter aircraft at 200 gpm.

Figure 7.6. R-14 Transportable Hydrant Refueling System.



7.3.2. R-22 Trailer-Mounted Transfer Pump. This is a trailer mounted, diesel powered 600-gpm pump (**Figure 7.7.**). It is typically used in conjunction with an FFU-15E filter separator to pump fuel from bulk storage tanks, fuel trucks or tanker aircraft to the R-14's 50,000-gallon bladders. The R-22 can also be used with a hose cart or skid-mounted filter separator to deliver fuel directly to aircraft or refueling vehicles.

Figure 7.7. R-22 Trailer-Mounted Transfer Pump.



7.3.3. **FFU-15E Skid-Mounted Filter Separator.** A skid-mounted 600-gpm filter separator used to remove contaminating particulates and water from fuel prior to pumping into fuel bladders. The FFU-15E can be configured for use with many different systems to provide clean, dry fuel (**Figure 7.8.**).

Figure 7.8. FFU-15E Skid-Mounted Filter Separator.



7.3.4. GRU-17E Aircraft Fuel-Servicing Unit. A caster mounted swivel-joint framework and fueling hoses to provide the R-14 with hot refueling capability (**Figure 7.9.**). The GRU-17E is a portable pantograph designed for refueling tactical aircraft during hot refueling operations (refueling aircraft with engine running or simultaneous weapons loading). It consists of four sections of pipe connected with swivel joints and mounted on casters. It is fully equipped with all components needed to operate the unit and only requires a fuel source for operation

Figure 7.9. GRU-17E Aircraft Fuel-Servicing Unit.



7.3.5. PMU-27M Pumping Assembly. A trailer-mounted, engine powered unit consisting of a 50-gpm pump, filter separator, with associated hoses, connections, nozzles and meter (**Figure 7.10.**). It is used to service small aircraft or vehicles, or transfer fuel into or out of four 55-gallon drums simultaneously, pumping from an external source and defueling aircraft auxiliary tanks. The unit is also a ground fuels-dispensing unit.

Figure 7.10. PMU-27M Pumping Assembly.



7.4. Fuel Bladders. Fuel bladders generally range in capacity from 500 gallons to 210,000 gallons (**Figure 7.11**). Typically, 10,000-gallon fuel bladders are used at low-demand sites such as vehicle refueling points. Larger 50,000-gallon fuel bladders support aircraft fuel storage and refueling and are commonly found with the R-14 refueling unit. The 210,000-gallon bladders are used for bulk fuel storage. Additional fuel bladder details are listed in **Table 7.1**. Refer to T.O. 37A12-15-1, *Collapsible Fuel Bladders*, for additional information relating to operation, service, repair, and berm construction details.

Figure 7.11. Fuel Bladders in Storage and Distribution Area.



Table 7.1. Collapsible Fuel Bladder Details.

Capacity (Gallons)	Bladder Dimensions												Weight Dry (Approx.) ² Pounds
	Full (Approximate) ¹						Empty						
	Length		Width		Height		Length		Width				
	Ft	In	Ft	In	Ft	In	Ft	In	Ft	In			
500	13	5	9	0	5	8	5	1	4	4	250		
3,000	12	6	12	6	4	0	14	0	14	0	210		
10,000	20	6	20	6	4	0	22	0	22	0	375		
20,000	26	6	22	6	5	2	28	0	24	0	680		
50,000	66	0	22	6	5	5	68	2	28	1	1,500		
50,000 ³	62	8	22	7	5	2	65	0	24	6	1,026		
210,000	68	5	68	5	6	5	70	0	70	0	5,000		
210,000 ³	72	5	73	4	5	6	74	4	73	2	4,217		

1-After settling (height is greater on initial fill)
 2-Tank only, no accessories
 3-Tanks produced by MPC Containment Systems after October 2008

7.5. Expeditionary Medical Support (EMEDS) Facilities. EMEDS Facilities (Figure 7.12.) consist of expandable equipment packages that range from a basic, rapid response facility to a 114-bed Air Force Theater Hospital (AFTH). Generally, AF beddowns are served by an EMEDS+25 Bed AFTH (described below) or smaller facility with no specialty UTCs attached. However, in a mature theater a broader range of care and services are usually centralized at key locations. EMEDS are equipped and staffed to provide medical support only, and is therefore dependent on CE and other base agencies for support. The following paragraphs provide a brief overview of EMEDS facilities. Refer to AFPAM 10-219, Volume 5, for more information on EMEDS.

Figure 7.12. Expeditionary Medical Support Facility.



7.5.1. EMEDS Basic. A four-bed clinic, deployable in initial and follow-on increments to provide primary medical and dental care, preventive medicine, environmental health, stabilization and medical evacuation preparation for up to 2,000 personnel. Initial module should be operational within 12 hours of arrival. Full deployment includes three small shelters with ECUs. The clinic requires a 15,000 sq ft site, 65 kW of power, 400 gallons per day (gpd) of potable water, 1,000 pounds of laundry service per week, biohazard waste disposal and lodging for 25 personnel.

7.5.2. EMEDS+10 Bed AFTH. This is a 10-bed AFTH. It is a modular add-on expansion of EMEDS Basic to support up to 3,000 personnel, including surgical and specialty care. It includes an additional three small shelters with ECUs. Total requirements increase to a 26,000 sq ft site, 100 kW of power, 800 gpd of potable water, 85 pounds per day (ppd) of ice, laundry service, biohazard waste disposal and lodging for 56 people.

7.5.3. EMEDS+25 Bed AFTH. This is a 25-bed AFTH. It is a modular add-on expansion of EMEDS+10, to support up to 5,000 personnel. It includes an additional three small shelters with ECUs. Its total requirements increase to 40,000 sq ft site, 200 kW of power, 1,430 gpd of potable water, 150 ppd of ice, laundry service, biohazard waste disposal and lodging for 86 people.

7.5.4. EMEDS+50 Bed AFTH. An estimated seven additional small shelters are included in this expansion. Total requirements increase to 50,000 sq ft site, 200 kW of power, 5,500 gpd of potable water, 300 ppd of ice, laundry service, biohazard waste disposal and lodging for 115 people.

7.5.5. EMEDS+114 Bed AFTH. An estimated 16 additional small shelters is included in this expansion. This is the maximum anticipated size for an expeditionary medical facility. Estimated requirements are an 110,000 sq ft site, 200 kW of power, 11,000 gpd of potable water, 675 ppd of ice, laundry service, biohazard waste disposal and lodging for 300 personnel.

7.6. Aeromedical Staging Facility (ASF). The ASF is an evacuation hospital capable of receiving and evacuating 250 injured or ill personnel every 24 hours ([Figure 7.13](#)). It is comprised of TEMPER tents and requires a 90,000 sq ft site, 200 kW of power, 12,000 gpd of potable water, 1250 ppd of ice, laundry service, biohazard waste disposal and lodging for medical staff.

7.7. Transportable Blood Transshipment Center (TBTC). The TBTC is a small facility used to store and ship frozen and liquid blood products and is normally collocated with medical facilities near a major airfield. It requires two Small Shelters, TEMPER tents, or ISO container shelters and a 4,000 sq ft site, 200 kW of power, 300 gpd of potable water, 800 ppd of ice and lodging for 12 personnel.

Figure 7.13. Aeromedical Staging Facility.

7.8. Navigational Aids (NAVAIDs). Navigational aids refer to the ground equipment and supporting facilities that provide electronic (radio and radar) assistance in the navigation of aircraft. Communications personnel install and operate NAVAIDs such as Tactical Air Navigation, Radar Approach Control or Precision Approach Radar, mobile microwave landing system, and mobile tower and communications equipment. These assets are not part of BEAR packages; however, engineers will provide site preparation and utilities. The footprint of many deployed NAVAIDs is determined during pre-survey coordination meetings, but siting generally requires a suitably sized cleared area on level ground with electrical power and vehicle access. Below are several types of deployable NAVAIDs that will usually require site preparation at contingency locations:

7.8.1. AN/TPN-19 Landing Control Central (Radar Set). The AN/TPN-19 radar set ([Figure 7.14.](#)) can be configured as a complete radar approach control (RAPCON) or ground controlled approach (GCA) facility. With all indicators and communications equipment operational, the unit is capable of taking over air traffic control (ATC) operations at busy airports. Depending on antenna location, the precision approach radar (PAR) system is capable of providing

service for up to four runways, but the unit can provide approach guidance to only one runway at a time. Normally, ten maintenance personnel can install this system in about 26 hours, not including site survey. However, during contingency situations with no augmentees assigned, the standard setup time is 36 hours.

Figure 7.14. Landing Control Central Surveillance Radar System.



7.8.2. AN/MPN-14K Landing Control Central (Radar Set). This unit can also be configured as a complete RAPCON or GCA facility. However, the set is limited to a single runway but has the capability of providing opposite direction runway operations with the aid of a transportable turntable. Ten maintenance personnel and six controllers are needed to install the system within 26 hours.

7.8.3. AN/TSW-7 Mobile Control Tower. The AN/TSW-7 mobile control tower ([Figure 7.15.](#)) provides ATC capabilities where no control tower exists (bare base operations) or where the fixed control tower is not operational. The unit has limited capabilities; however, it provides controllers with the minimum items necessary to rapidly launch and recover (to include silent launches) participating aircraft in the most expeditious manner. Seven maintenance personnel should have the mobile tower operational within 16 hours.

7.8.4. AN/TRN-45 Mobile Microwave Landing System (MMLS). The MMLS (**Figure 7.16.**) is a lightweight, transportable ground-based precision guidance approach system for MLS avionics equipped aircraft. Normal setup is a collocated configuration where elevation and azimuth antennas are situated together at the typical ILS glide slope antenna location. Three trained personnel can set up the MMLS in a co-located configuration in 60 minutes. Set up in a split-site configuration will take 2 hours (times do not include site survey or transportation time).

7.8.5. AN/TRN-26 Tactical Air Navigation (TACAN). The AN/TRN-26 TACAN (**Figure 7.17.**) system is designed for use at remote landing strips and forward operating areas. The system provides radio navigation information (bearing, identification, and distance). Maintenance personnel can have the TACAN operational within 4 hours.

7.8.6. AN/TRN-41 TACAN. The AN/TRN-41 is a portable, lightweight, air droppable, unmanned TACAN designed to provide bearing, facility identification, and distance information. The TACAN transmits continuous bearing information to an unlimited number of aircraft and provides slant range distance information. Three trained personnel should have the system operational in 4 hours.

Figure 7.15. Mobile Control Tower.



Figure 7.16. Mobile Microwave Landing System.



Figure 7.17. Tactical Air Navigation Unit.



7.9. International Organization for Standardization (ISO) Containers.

These facilities serve as their own shipping container and as a shelter once deployed. Commonly sized at 8 feet x 8 feet x 20 feet, some are expandable to provide about 400 square feet. They are normally used for specialized purposes such as hospital operating rooms or command posts.

7.10. Expandable Light Air Mobile Shelter (ELAMS). The ELAMS is an all-purpose soft-walled shelter used as maintenance shops, control centers, storage, office area, etc. (**Figure 7.18.**). Standard expanded configuration is 14.8 feet long by 20.25 feet wide by 8 feet high. The shelter has a 120/208 VAC, 60-cycle, 3-phase, 5-wire electrical input. A minimum of five personnel can safely assemble the structure in about six hours (30 labor hours). See **Table 7.2.** for environmental limitations.

Figure 7.18. Expandable Light Air Mobile Shelter.



Table 7.2. ELAMS Environmental Limitations.

Temperature	-25° F to 125° F
Solar Load	200° F
Wind Load	60 knots (Sustained); Up to 90 knots (Gusts)
Snow Load	40 lbs per square inch
Floor Load	120 lbs/psi (Center); 80 lbs/psi (Expanded)

7.11. K-Span Structures. This is an arched building made on-site from rolls of galvanized steel (**Figure 7.19.**) using an air-transportable trailer-mounted automatic building machine. The machine forms structural arches in any desired span between 12 ft and 80 ft, as well as straight sections for end walls. The arches and end wall sections are then erected onto a concrete foundation and seamed together using a portable electric seaming machine. The continuous seams eliminate the need for fasteners, thereby simplifying construction and making the building watertight. The facilities are commonly used as storage buildings or maintenance shops and are typically constructed by RED HORSE personnel.

Figure 7.19. K-Span Facility Under Construction.



7.12. Revetments. Revetments are theater WRM assets used to protect parked aircraft or other high-value resources. B-1 revetments are assembled from corrugated steel panels into sections 6 feet 11 inches wide, 12 feet long, and 16 feet high. A single B-1 kit provides enough panels for twenty-one 12-foot sections, for a total length of 252 feet. Sections can be joined end to end for straight revetments, or butted together at right angles for "U" shapes, "E" shapes, etc. (see **Figure 7.20.** for a typical B-1 Revetment layout). One kit will protect one fighter in "U" shape and flow-thru designs. For clustered arrangements, three kits will protect four fighters. Fill revetments with earth and cap to prevent dust from blowing out or water from accumulating. See T.O. 35E4-170-2, *Aircraft Revetment Kit, Type B-1*, and AFPAM 10-219, Volume 2, for construction details.

Figure 7.20. B-1 Revetment Layout Plan and Elevation (16-Foot High).

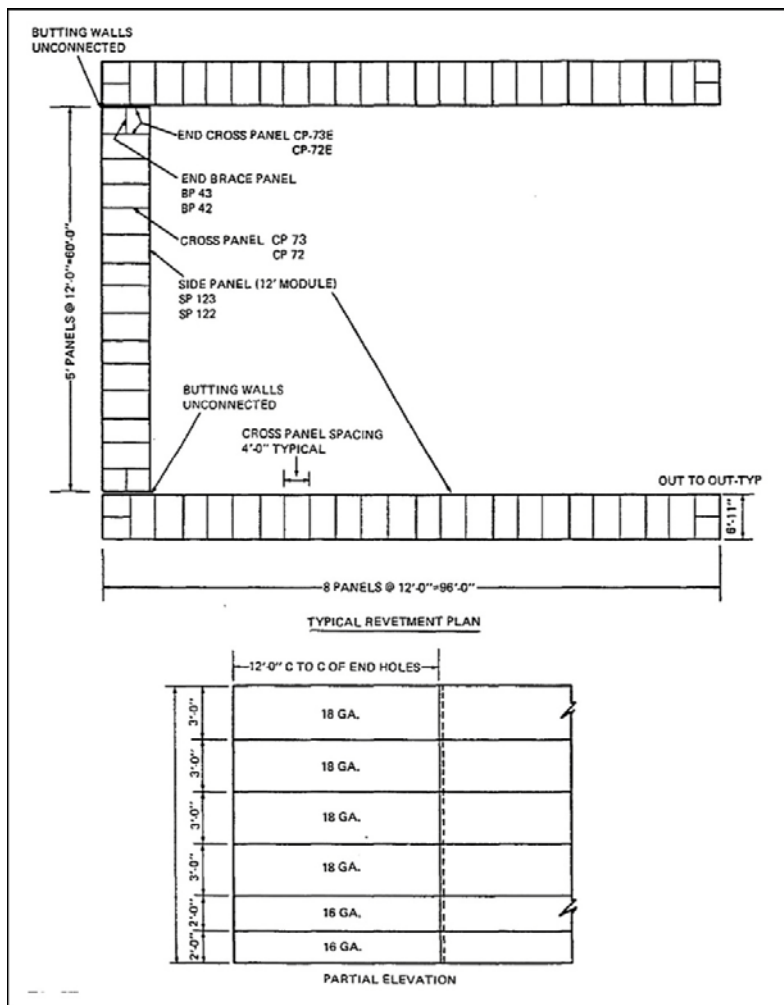

7.13. Force Provider Facilities and Equipment. This is a US Army expeditionary infrastructure package, normally used at theater reception points, intermediate staging bases, disaster relief operations or in other situations where relatively stable and robust expeditionary infrastructure is appropriate. A single Force Provider set includes all materiel necessary to provide quality food, billeting and hygiene services for 550 personnel (**Figure 7.21.**). TEMPER tents, environmental control units, 60 kW tactical quiet generators, 20,000-gallon water bladders, 400-gallon water buffalo trailers, floodlights and wastewater disposal vacuum pump trailers are compatible with Air Force BEAR equipment. However, Force Provider utility distribution systems and containerized shower, latrine and laundry units are not directly compatible with BEAR utility systems, and may need locally developed adapters or fittings. Force Provider sets are typically erected by Quartermaster companies. If required, water production (ROWPUs) and high-voltage power production (MEP-012s) are provided by specialized units.

Figure 7.21. Force Provider Assets.



HERBERT J. CARLISLE, Lt General, USAF
DCS/Operations, Plans, and Requirements (A3/5)

Attachment 1

GLOSSARY OF REFERENCES AND SUPPORTING INFORMATION

References

AFDD 3-34, *Engineer Operations*, 19 September 2011

AFDD 4-0, *Combat Support*, 23 March 2005

AFH 10-222, Volume 3, *Civil Engineer Guide to Expeditionary Force Protection*, 1 May 2008

AFH 10-222, Volume 4, *Environmental Guide for Contingency Operations*, 1 March 2007

AFH 10-222, Volume 5, *Guide to Contingency Electrical Power System Installation*, 1 July 2008

AFH 10-222, Volume 6, *Guide To Bare Base Facility Erection*, 1 July 2008

AFH 10-222, Volume 7, *Emergency Airfield Lighting System (EALS)*, 1 December 2011,

AFH 10-222, Volume 8, *Guide to Mobile Aircraft Arresting System Installation*, 1 May 2006

AFH 10-222, Volume 9, *Reverse Osmosis Water Purification Unit Set-Up and Operation*, 1 April 2011

AFH 10-222, Volume 10, *Civil Engineer Camouflage, Concealment & Deception (CCD) Measures*, 18 February 2011

AFH 10-222, Volume 11, *Contingency Water System Installation and Operation*, 19 May 2011

AFH 10-222, Volume 12, *Guide To Bare Base Mechanical Systems*, 23 April 2009

AFH 10-222, Volume 14, *Guide to Fighting Positions, Obstacles, and Revetments*, 1 August 2008

AFH 10-222, Volume 16, *Guide for Use of the Minimum Airfield Operating Surface Marking System*, 1 December 2005

AFI 10-210, *Prime Base Engineer Emergency Force (BEEF) Program*, 15 November 2010

AFI 10-211, *Civil Engineer Contingency Response Planning*, 22 September 2008

AFI 10-401, *Air Force Operations Planning and Execution*, 7 December 2006

AFI 10-404, *Base Support and Expeditionary Site Planning*, 9 March 2004

AFI 24-203, *Preparation and Movement of Air Force Cargo*, 2 November 2010

AFI 25-101, *War Reserve Materiel (WRM) Program Guidance and Procedures*, 2 May 2005

AFI 32-1064, *Electrical Safe Practices*, 25 May 2006

AFMAN 23-110, *USAF Supply Manual*, 1 April 2009

AFMAN 33-363, *Management of Records*, 1 March 2008

AFMAN 48-138 (IP), *Sanitary Control and Surveillance of Field Water Supplies*, 1 May 2010

AFPAM 10-219, Volume 5, *Bare Base Conceptual Planning Guide*, 1 June 1996

AFPD 10-2, *Readiness*, 30 October 2006

Agile Combat Support (ACS) CONOPS, 2007

Basic Expeditionary Airfield Resources (BEAR) CONOPS, 2005

Definitive Guide To Bear Base Assets, 49 MMG, 16 December 2009

T.O. 35CA2-2-10-1, *Secondary Distribution Center (JEU-191/E)*, 15 August 1984

- T.O. 35CA2-2-17-1, *Operation and Maintenance Manual, Secondary Distribution Center (SDC) 150 KVA (DPGDS)*, 13 December 2006
- T.O.35CA6-1-211, *Power Distribution Panel (PDP), 25KW*, 15 May 2002
- T.O. 35CA6-1-231, *Power Distribution Panel (PDP) 60KW*, 14 November 2003
- T.O. 35C2-3-444-32, *Generator Set, Skid Mounted, Tactical Quiet, MEP-806B, 60KW, 50/60 Hz*, 1 July 2000
- T.O. 35C2-3-474-1, *Generator Set, Diesel Engine-Driven, Wheel-Mounted 750-KW, 3-Phase, 4-Wire, 2200/3800 and 2400/4160 Volts*, 11 January 1990
- T.O. 35E2-2-7, *AM-2 Airfield Landing Mat and Accessories*, 1 April 1974
- T.O. 35E2-6-1, *Minimum Airfield Operating Surface Marking System (MAOSMS)*, 5 September 1995
- T.O. 35E35-3-1, *Shave Stand, Bare Base*, 1 September 1987
- T.O. 35E35-4-1, *Shower Facility, Bare Base*, 13 May 2010
- T.O. 35E35-5-1, *Field-Deployable Latrine Assembly*, 1 May 2003
- T.O. 35E4-132-1, *Bare Base General Purpose Shelter*, 1 September 1976
- T.O. 35E4-133-1, *Bare Base 76-Foot Aircraft Maintenance Hangar*, 23 December 2002
- T.O. 35E4-169-31, *BEAR Base Harvest Falcon/Eagle Electric Kitchen with Mess Kit Laundry*, 1 May 2006
- T.O. 35E4-170-2, *Aircraft Revetment Kit, Type B-1*, 6 May 1982
- T.O. 35E4-183-1, *Frame-Supported Tensioned Fabric Shelter*, 11 December 1991
- T.O. 35E4-216-1, *Bare Base Dome Shelter*, 30 September 2005
- T.O. 35E4-219-1, *Large Area Maintenance Shelter*, 01 March 2010
- T.O. 35E4-235-1, *Single Pallet Expeditionary Kitchen*, 18 June 2010

- T.O. 35E5-6-1, *Tent, Extendable, Modular, Personnel (TEMPER)*, 1 March 1993
- T.O. 35E5-6-11, *Alaska Small Shelter System (AKSSS)*, 1 December 2004
- T.O. 35E5-6-21, *California Medium Shelter System*, 9 March 2000
- T.O. 35E7-2-11-11, *Heater H-1 Diesel Fueled, Portable, Duct Type 400,000 BTU/H*, 17 June 2010
- T.O. 35E7-3-4-1, *Heater, 130K Multi-Fueled, Portable, Duct Type 130,000 BTUH Model Polar Bear1*, 1 July 2007
- T.O. 35E7-4-27-1, *Heater, Water, Liquid Fuel, M-80*, 30 June 2005
- T.O. 35E8-2-10-1, *Arresting Systems, Aircraft, Mobile*, 1 September 2009
- T.O. 35E9-314-1, *Field-Deployable Environmental Control Unit (Models FDECU-2, FDECU-3, FDECU-4, FDECU-5, & FDECU-9)*, 17 October 2008
- T.O. 35F14-1-1, *Deployable Power Generation and Distribution System (DPGDS) for a Primary Switch (PS)*, 15 June 2007
- T.O. 35F5-3-17-1, *Lighting System, Airfield, Emergency A/E82U-2*, 1 October 2000
- T.O. 35F5-5-21-1, *Flood Light, Trailer Mounted, Type TF-2*, 1 June 2006
- T.O. 35F5-5-22-1, *Remote Area Lighting System (RALS)*, 29 January 2004
- T.O. 37A12-15-1, *Collapsible Fuel Bladder*, 30 January 2004
- T.O. 40R7-6-1, *Advanced Design Refrigerator, 300 Cubic Foot (ADR-300)*, 7 February 2007
- T.O. 40W4-20-1, *Operation and Maintenance Instruction With IPB – 1500 Reverse Osmosis Water Purification Unit (ROWPU)*, 1 April 2007
- T.O. 40W4-21-1, *Basic Expeditionary Airfield Resources (BEAR) Water System PN 3000001*, 1 May 2007

T.O. 40W4-21-1, SWP 007 05, 3,000 Gallon Collapsible Fabric Tank Maintenance, 1 May 2007

T.O. 50D1-4-11, Self-Help Laundry, 1 May 2005

Prescribed Forms

No prescribed forms are implemented in this publication.

Adopted Forms

AF Form 847, *Recommendation for Change of Publication*.

Abbreviations and Acronyms

ACC—Air Combat Command

ACH—Aircraft Hangar

ACS—Agile Combat Support

ADR—Advanced Design Refrigerator

AF—Air Force

AFCESA—Air Force Civil Engineer Support Agency

AFH—Air Force Handbook

AFI—Air Force Instruction

AFMAN—Air Force Manual

AFPAM—Air Force Pamphlet

AFPD—Air Force Policy Directive

AFRIMS—Air Force Records Information Management System

AFTH—Air Force Theater Hospital

AKSSS—Alaska Small Shelter System

ANG—Air National Guard

AOR—Area of Responsibility

ASF—Aeromedical Staging Facility

BCE—Base Civil Engineer

BE—Bioenvironmental

BEAR—Basic Expeditionary Airfield Resources

BIPT—BEAR Integrated Process Team

BOB—BEAR Order of Battle

BSRB—BEAR Systems Readiness Board

BTU—British Thermal Unit

BTUH—British Thermal Unit/Hour

CAF—Combat Air Forces

CE—Civil Engineer

CF—Cubic Feet

CoP—Community of Practice

DOD—Department of Defense

DODI—Department of Defense Instruction

DOTMLPF—Doctrine, Organization, Training, Materiel, Leadership and Education, Personnel, and Facilities

DTG—Distance-To-Go

DX—Direct Expansion

EALS—Emergency Airfield Lighting System

EALS II—Expeditionary Airfield Lighting System

ECU—Environmental Control Unit

ELAMS—Expandable Light Air Mobile Shelter

EMEDS—Expeditionary Medical Support

EPA—Environmental Protection Agency

ESC—Expandable Shelter Container

FDECU—Field-Deployable Environmental Control Unit

FMSE—Fuels Mobility Support Equipment

FORCE—Fuels Operational Readiness Capability Equipment

FSTFS—Frame-Supported Tensioned Fabric Shelter

GOSG—General Officer Steering Group

GP—General Purpose

GPH—Gallons Per Hour

GPM—Gallons Per Minute

HQ—Headquarters

HVAC/R—Heating, Ventilation, Air Conditioning, and Refrigeration

HZ—Hertz

IAW—In accordance with

IC—Insulated Container

IPB—Illustrated Parts Breakdown

IPU—Interim Power Unit

ISO—International Organization for Standardization

KW—Kilowatt

LAMS—Large Area Maintenance Shelter

LOGDET—Logistics Detail

LOGMOD—Logistics Module

LOX—Liquid Oxygen

LPH—Liters Per Hour

LWH—Length/Width/Height

MAAS—Mobile Aircraft Arresting System

MAF—Mobility Air Forces

MAOS—Minimum Aircraft Operating Surface

MOS—Minimum Operating Strip

MAJCOM—Major Command

MEFPAK—Manpower and Equipment Force Packaging

MEP—Mobile Electric Power

MSS—Medium Shelter System

NATO—North Atlantic Treaty Organization

NAVAIDS—Navigational Aids

NVG—Night Vision Goggle

OPR—Office of Primary Responsibility

ORT—Operating Remote Terminal

PDC—Primary Distribution Center

PDP—Power Distribution Panel

POL—Petroleum, Oil, and Lubricants

Prime BEEF—Prime Base Engineer Emergency Force

PSC—Primary Switching Center

PSI—Pounds Per Square Inch

RALS—Remote Area Lighting System

RAPCON—Radar Approach Control

RDS—Records Disposition Schedule

ROWPU—Reverse Osmosis Water Purification Unit

RU—Refrigeration Unit

SCFM—Standard Cubic Feet per Minute

SDC—Secondary Distribution Center

SHL—Self-Help Laundry

SORTS—Status of Resources and Training System

SPEK—Single Pallet Expeditionary Kitchen

SSS—Small Shelter System

STANAG—Standardization Agreement (NATO)

TACAN—Tactical Aid to Navigation

TBTC—Transportable Blood Transshipment Center

TEMPER—Tent Extendable Modular Personnel

TM—Technical Manual

T.O.—Technical Order

TQG—Tactical Quiet Generator

TTP—Tactics, Techniques, and Procedures

UDM—Unit Deployment Manager

UGR-H & S—Utilized Group Rations-Heat and Serve

USACE—US Army Corps of Engineers

UTC—Unit Type Code

V—Volts

VAC—Volts Alternating Current

WRM—War Readiness Materiel

Terms

Air Force Civil Engineer Support Agency (AFCESA)—A field operating agency (FOA) located at Tyndall Air Force Base, Florida. The Readiness Support Division (HQ AFCESA/CEX) acts as the Air Force program manager for Base Civil Engineer (BCE) Contingency Response Planning.

Bare Base—An installation having minimum essential facilities to house, sustain, and support operations to include, if required, a stabilized runway, taxiways, and aircraft parking areas. A bare base must have a source of water that can be made potable. Other requirements to operate under bare base conditions form a necessary part of the force package deployed to the bare base.

Basic Expeditionary Airfield Resources (BEAR)—Facilities, equipment, and basic infrastructure to support the beddown of deployed forces and aircraft at austere locations; a critical capability to fielding expeditionary aerospace forces. Also known as BEAR, the resources include tents, field kitchens, latrine systems, shop equipment, electrical and power systems, runway systems, aircraft shelters, and water distribution systems needed to sustain operations.

Beddown—A location at which a deploying unit operates during a contingency. It is usually, but not always, in the area of responsibility.

Logistics Module (LOGMOD). A computer software program that is used to manage logistics equipment and supply database for Air Force Unit Type Codes (UTCs).

Minimum Aircraft Operating Surface—The minimum surface on an airfield which is essential for the movement of aircraft. It includes the aircraft dispersal areas, the minimum operating strip, and the taxiways between them.

Minimum Operating Strip—A runway which meets the minimum requirements for operating assigned and/or allocated aircraft types on a particular airfield at maximum or combat gross weight.

Solar Load—The increase in temperature for a room or building generated by the sun's rays.

Attachment 2

ENGINEER REACHBACK AND OTHER USEFUL LINKS

Table A2.1. Useful Organizational Links.

Site	Link
Air Force Civil Engineer Support Agency (AFCESA)	http://www.afcesa.af.mil/
USACE Protective Design Center (PDC)	https://pdc.usace.army.mil/
Air Force Center for Engineering and the Environment (AFCEE)	http://www.afcee.af.mil/
Whole Building Design Guide (WBDG)	http://www.wbdg.org/
Department of Commerce, Electric Current Worldwide	http://www.trade.gov/mas/ian/ecw/
Construction Criteria Base (CCB)—Whole Build Design Guide (WBDG)	http://www.wbdg.org/ccb
USACE—Afghanistan Engineer District Design Library	http://www.aed.usace.army.mil/Design.asp
Air Force Publications and Forms	http://www.e-publishing.af.mil/
USACE Engineer Research and Development Center	http://erdc.usace.army.mil/
DOD Issuances (Publications, Directives, Guides, Etc.)	http://www.dtic.mil/whs/directives/

Attachment 3**BEAR AIR-CONFIGURED UTC DETAILS**

Table A3.1. provides logistics details for BEAR UTCs configured for air shipment (minus shipping and packing materials).

Table A3.1. Air-Configured BEAR UTCs.

Engineering Management (XFA19)	Qty
Small Shelter Tan	2
25kW Power Distribution Panel (PDP)	2
Desk w/Lock	4
Fire Extinguisher	2
Mobility Readiness Spares Package (MRSP) Misc Loose	1
CE Power Production/Electric/Supply (XFA21)	
Small Shelter Tan	2
25kW Power Distribution Panel (PDP)	3
Fire Extinguisher	3
5-80kW Load Bank	1
Floodlight, Tripod	10
MRSP (Misc Loose)	2
Plastic Bin	1
MRSP Support CE Power Pro (8145)	1
MRSP Support CE Power Pro (5411)	1
ESC Power Pro FCY	1
Wooden Box	1

Table A3.1. (Continued)

CE Maintenance (XFACX)	Qty
Small Shelter, Tan	1
Vise Bench	2
125-GPM Pump Diesel	1
25kW Power Distribution Panel (PDP)	1
Grinding Machine	1
Hoist Chain	1
Pump Dispensing	1
Jack Hydraulic 20 Ton	1
Saw, Circular	1
Fire Extinguisher	1
MRSP Support CE Maintenance	4
Plastic Bin	3
Welding Machine	1
Brazing Set	1
CE Industrial (XFAEC)	
Small Shelter, Tan	6
Medium Shelter, MSS	1
Fire Extinguisher DC	7
MRSP Support CE Industrial	2
25kW Power Distribution Panel (PDP)	6
Pump, Centrifugal	1
Cutter Circle	1

Table A3.1. (Continued)

CE Industrial (XFAEC) Cont'd	Qty
Cleaner Vacuum	1
Vice Pipe Chain	1
Threading Set	1
Cutter Drum	1
Hoist Wire Rope	1
Pump, Disp 10 GPM	1
Compressed Air 200 PSI	1
Welding Machine	1
Compressed Air 100 PSI	1
Pavement Breaker	1
Gas Cylinder Box	1
MRSP Support Gas Cylinder	1
Power Distribution (XFAEG)	
Reel Assembly	2
MRSP Support Wire	6
Water Source Run (XFAMS)	
Diesel Pump, 400 GPM	1
Various Hoses	1
Flaking Box	10
Hose Bridge System	8
SRC Run Partial	1
SRC Run Hoses	10

Table A3.1. (Continued)

Water Production 1500 ROWPU (XFAMP)	Qty
1500 GPH ROWPU	2
Water Distribution Initial (XFA17)	
Water Distribution Initial	3
Water Distribution Initial, Partial	2
Water Distribution Initial Parts	7
Water Distribution Partial	5
Billeting (XFABL)	
Small Shelter Tan	12
25kW Power Distribution Panel (PDP)	12
Fire Extinguisher	12
MRSP Support Billet	3
High Power (XFAPH)	
Generator, MEP-12	2
Operating Remote Terminal (ORT)	1
Primary Switching Center	1
MRSP Support High Power	1
Fire Extinguisher	2
Wooden Box # 1	4
Bladder, Gallon 10K	2
Berm Bladder Support	2

Table A3.1. (Continued)

Low Power Industrial (XFA16)	Qty
MEP-806 Generator	2
Wheel Kit, Generator	2
A-Panel	2
MRSP Support Low Power Industrial	1
Wooden Box	1
Combat AF Initial Support (XFA14)	
Small Shelter Tan	8
25kW Power Distribution Panel (PDP)	8
Fire Extinguisher DC	16
MRSP Misc Loose	2
Medium Shelter, MSS	8
MEP-806 Generator	1
Wheel Kit, Generator	1
Mobility AF Support (XFA3C)	
Small Shelter	8
Medium Shelter	6
25kW Power Distribution Panel (PDP)	8
Fire Extinguisher DC	14
MRSP Support Mobility AF SPT	2
MRSP Misc Loose	1
Desk w/Lock	24
MRSP SPT Table	20
MRSP SPT Bench	40

Table A3.1. (Continued)

Combat AF Add-On Support (XFAC6)	Qty
Small Shelter Tan	1
Medium Shelter, MSS	2
25kW Power Distribution Panel (PDP)	1
Fire Extinguisher DC	3
MRSP Misc Loose	1
Combat AF Follow On Support (XFACB)	
Small Shelter Tan	4
25kW Power Distribution Panel (PDP)	4
Fire Extinguisher DC	4
MRSP Support CAF	1
MB-8 Compressor	1
Aircraft Wheel-Tire P1	1
Aircraft Wheel-Tire P2	1
Bead Breaker	1
Puller Cup	1
Safety Guard	1
Entomology (XFACD)	
Wooden Box	1
MRSP Support Entomology	2
Wooden Crate	1
Environmental Control Unit (XFAAC)	
Field-Deployable Environmental Control Unit (FDECU)	12

Table A3.1. (Continued)

Fire Ops/Crash Rescue (XFACF)	Qty
Small Shelter Tan	4
25kW Power Distribution Panel (PDP)	4
Fire Extinguisher DC	4
MRSP Misc Loose	2
Desk Field w/Lock	4
Chaplain Support (XFAGC)	
Small Shelter Tan	1
25kW Power Distribution Panel (PDP)	1
Public Address	1
VCR VHS	1
Desk Field w/Lock	2
Jug Vacuum 10 Gal	2
Fire Extinguisher DC	1
Monitor Color 19"	1
MRSP Support Chaplain	1
Flag, Christian	1
Flag, Jewish	1
Stand, Flagstaff	3
ADR-300 Refrigerator (XFACH)	
ADR300 Refer	1
MRSP Support ADR300 Refer	1

Table A3.1. (Continued)

550 Kitchen (XFAKC)	Qty
Tent, 550 Kitchen Tan	1
MRSP Misc Loose	6
Preparation Table	4
Mixing Bowl 20 Gal	1
Frying and Braising Pan	2
Shelving Food	9
Table, Folding 36"	2
Desk Field w/Lock	1
Cabinet Filing	1
10 Gal Jug	2
Fire Extinguisher	6
Food Cutter/Mixer	1
M80 Water Heater	1
Coffee Food Counter	1
Field Kitchen Exhaust System (FKES)	2
550 Harvest Eagle Electric Kitchen (HEEK) Water System	1
550 HEEK Power System	1
Meat Slicer	1
Harvest Eagle Mess Kit Laundry (HEMKL) Power System	1
Tent TEMPER Tan	2
Field Deployable Environmental Control Unit (FDECU)	4
MRSP Support Lumber	255
MRSP Support Plywood	75

Table A3.1. (Continued)

Shower/Shave/Latrine (XFALC)	Qty
M80 Water Heater	1
Waste/Water Pump	1
25kW PDP	2
Small Shelter Tan	2
Fire Extinguisher	2
MRSP Support Shower/Shave	1
Lavatory Assembly	1
Shower Assembly	1
Latrine Assembly	1
MRSP Support Lumber	102
MRSP Support Plywood	40
Self-Help Laundry (XFALS)	
Small Shelter Tan	2
Dryers	10
Washers	10
Water Heater	4
Fire Extinguisher DC	4
MRSP Support SHL	2
SHL, Partial	9
Hose	2
Pump	2
Electric Box#1	2

Table A3.1. (Continued)

Munitions Support (XFAMU)	Qty
Small Shelter	1
25kW Power Distribution Panel (PDP)	1
Fire Extinguisher DC	2
MRSP Misc Loose	1
Large Area Maintenance Shelter (XFACJ)	
ACH LAMS 1	1
ACH LAMS 2	1
ACH LAMS 3	1
ACH LAMS 4	1
150# Halon Extinguisher	2
Fire Extinguisher DC	4
Wooden Box	1
MRSP Support LAMS	1
Barrier Maintenance (XFACL)	
Medium Shelter, MSS	1
Extinguisher, Fire 150lb	4
Wooden Box	1
MRSP Support Barrier Maintenance	1
Fire Extinguisher	1
Disk Loading Machine	1
Cammo Sets (XFANC)	
MRSP Support Cammo Nets A	200

Table A3.1. (Continued)

Low Power Housekeeping (XFAPL)	Qty
MEP-806 Generator	5
Wheel Kit - Gen	5
MEP-805 Generator	3
Whl Kit, Gen MEP-805	3
A-Panel	8
MRSP Support Low Power Hsk	1
Wooden Box	1
Postal Support (XFAPS)	
Medium Shelter, MSS	2
FDECU	2
Fire Extinguisher	1
MRSP Support Postal	1
Wooden Box	1
Mobile Aircraft Arresting System (XFAR4)	
MRSP Support MAAS	6
Nitro Cylinder Box	2
Nitrogen, Technco184	2
MAAS Trailer	2
MAAS Sheave System	2
Wooden Box	1

Table A3.1. (Continued)

130K Heaters (XFACW)	Qty
130K Heater	12
130K Metal Exhaust Pipes	12
130K Air Ducts	24
Remote Area Lights (XFAZC)	
RALS	2
MRSP Support RALS Cable	2
Vehicle Ops/Mx (XFAVC)	
Small Shelter	1
Battery Charger	2
Machine Key Dupl.	1
Bead Breaker	2
Tester, Electrical	1
Cutter, Bolt	1
Vise Bench	2
Desk Field w/Lock	2
25kW Power Distribution Panel (PDP)	1
Porto Power 4Ton	1
Truck Lift, Wheel	1
Table Work Hard	6
Fire Extinguisher	1
MRSP Misc Loose	2
Plastic Bin	3
Hoist Chain	1

Table A3.1. (Continued)

Vehicle Ops/Mx (XFAVC) Cont'd	Qty
Grinding Machine	1
MRSP Support Vehicle Ops	2
Mounter	1
Tire Dunker	1
Jack 10Ton	2
Welding Machine	1
Trestle, Hoist	1
Jack, 4Ton	2
Cabinet, Tool, Mobile	10
150# Halon Extinguisher	2
Lift Trans 2K	2
Jack Hyd/20Ton	1
Jack, Dolly Type, Hyd	1
Pressure Cleaner	1
Kit, Hydr, Hose Rep	1
Safety Guard	1
Fueling/Defueling	1
Mounter, Tire	1
Arbor Hand Press	1
Veh Mx Set/Air Control	1
Veh Mx Set/Air Hose Asse	1
Comp Air 200PSI	1
Wooden Box	4

Table A3.1. (Continued)

Combat Supply (XFASC)	Qty
Small Shelter Tan	4
25kW Power Distribution Panel (PDP)	4
Fire Extinguisher DC	4
MRSP Support Combat Supp	2
Scales 10,000lbs	4
Banding Machine	1
Wooden Box	1
Concertina Wire (XFAWR)	
Concertina Wire Box	2
MRSP Support CWire	480
MRSP Support Gloves	2
Mortuary Support (XFAXN)	
Small Shelter Tan	1
25kW Power Distribution Panel (PDP)	1
Fire Extinguisher DC	1
MRSP Support Mortuary	1
Truck Casket	1
Table Operating	2
Desk Field w/Lock	1
Transfer Case	15
ADR 300	1
MRSP Support Refer	1

Table A3.1. (Continued)

Water Dist Follow-On (XFA18)	Qty
Water Distribution	4
4K Dome Shelter (XFAAB)	
4K Dome	3
Fire Extinguisher DC	2
MRSP Support 4K Dome Shelter	1
AM2 Matting (XFAAM)	
AM-2 Matting	6
8K Dome Shelter (XFAAD)	
8K Dome Shelter	4
Fire Extinguisher DC	4
MRSP Support 8K Dome Shelter	1
Tactical Field Exchange (XFACC)	
Small Shelter, Tan	1
25kW Power Distribution Panel (PDP)	1
Fire Extinguisher	1
MRSP Support TFE	1
Desk Field w/Lock	1
Wooden Box	2
Filing Cabinet, 1Drw	1
Shelving Food	6
Calculator	1

Table A3.1. (Continued)

High Line Dock (XFAHL)	Qty
Highline Dock Assembly	1
Traffic Management (XFARB)	
Comp Air 200PSI	1
Saw Radial	1
Wooden Box	2
Saw Circular	1
Scale Platform	1
MRSP Support Traffic Management	1
Secondary Distribution Center (XFASD)	
Distribution Box SDC	2
MRSP Support SDC	2
Wooden Box	2
Single Pallet Expeditionary Kitchen (XFATF)	
Medium Shelter, MSS	1
Generator, 2KW	1
Tray Ration Heater	1
Field Sanitation Unit	1
Fire Extinguisher	4
MRSP Support SPEK	1
MRSP Support Bench	16
MRSP Support Table	20

Table A3.1. (Continued)

Admin Support (XFAWC)	Qty
Small Shelter Tan	4
25kW Power Distribution Panel (PDP)	4
Fire Extinguisher DC	4
MRSP Support Admin	1
Desk Field w/Lock	8
Filing Cabinet, 1 DWR	1
TF-2 Lightcart (XFA23)	
TF-2 Lightcart	2
Water Extension (XFAMX)	
Water Ext. Pkg.	1
Expeditionary Airfield Lights (XFAYC)	
EALS Trailer	4
EALS MEP-805A Generator	2
Rally Box	5
MRSP/Support Kit	1