

TERMITE TREATED SLOPED WOOD BLOCKING

24 GA. MIN. PREFINISHED GALVANIZED STEEL COPING WITH CONCEALED SPLICE PLATES. CONTINUOUS FRONT CLEAT. FASTEN BACK LEG AND CLEAT AT 8" O.C.

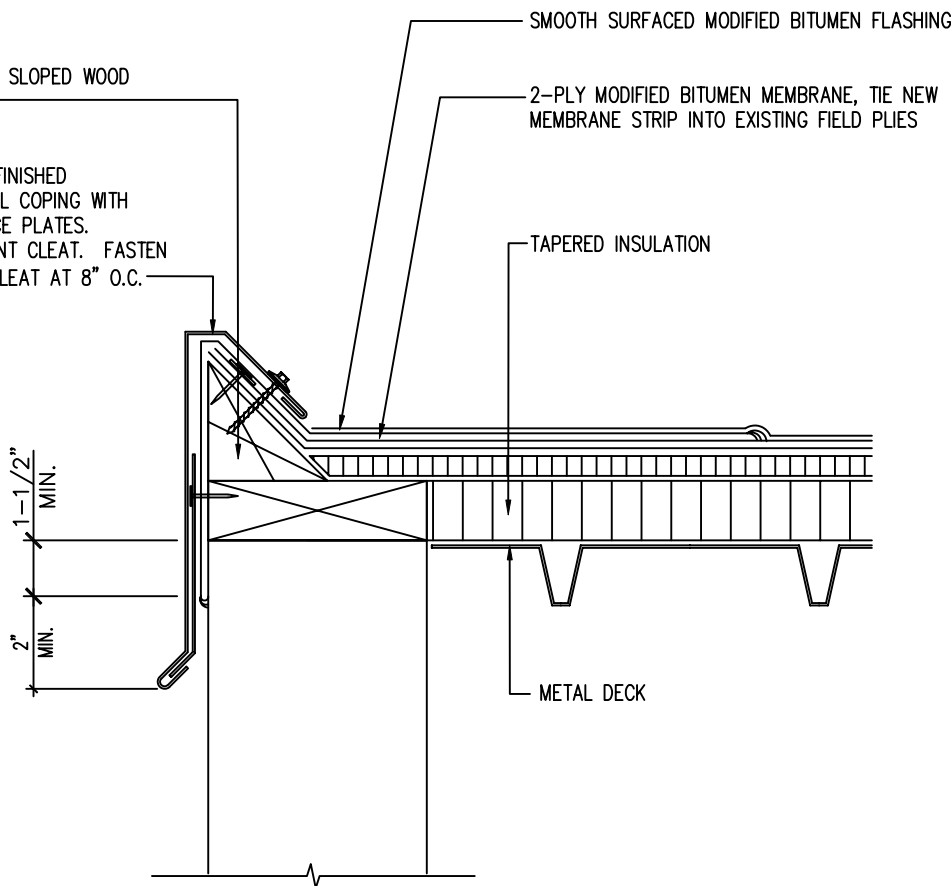

**KEY CONCEPTS:**

The dimensions and material relationships shown in this detail are **not to scale** and have been exaggerated for clarity. Actual dimensions will vary, and should be carefully coordinated with sequencing and construction tolerances to ensure the long-term durability and performance of this and similar roofing details.

Interface conditions between building envelope materials, components and systems should be fully detailed in a manner that is both technically sound and serviceable. Detailing should, at a minimum, allow for coordination of drainage planes; allow for thermal and moisture-induced changes in material properties and differential thermal movement; and allow for in-service deflection, shrinkage, creep and similar behavior considered to be within the allowable structural limits of the project without compromise to the weather-tight integrity and thermal performance of the building envelope.

The air barrier is typically formed by the roofing membrane and/or the roofing membrane and the roofing deck; a localized interior side air barrier may be needed in addition to this to mitigate interior moisture-laden air from coming in contact with the roof deck.

See the General section of the WBDG for additional information and guidance.

**ROOFING SYSTEM  
PENTHOUSE EDGE  
DETAIL**

CONCEPTUAL – NOT FOR CONSTRUCTION

The details, graphics and related information shown above are intended to illustrate basic design concepts and principles only and should be considered collectively with the appropriate narrative sections of the Whole Building Design Guide (WBDG). The information contained herein is not intended for actual construction, and is subject to revision based on changes and/or refinements in local, state and national building codes, emerging building envelope technologies, and advancements in the research and understanding of building envelope failure and failure mechanisms. The actual design and configuration of these and similar details will vary based upon applicable local, state and national building code requirements, climatic considerations, and economic constraints unique to each project. Full compliance with the manufacturer's recommendations and recognized industry standards for each building envelope material, component and system specified for this and similar roof assemblies is recommended, and should be reflected in the appropriate sections of the project specifications.