

**NOTICE OF GROUP
VALIDATION**

INCH-POUND

WW-P-541E
NOTICE 1
29 MAY 2001

FEDERAL SPECIFICATION

PLUMBING FIXTURES (GENERAL SPECIFICATION)

The following specification sheets of WW-P-541E have been reviewed and determined to be valid for use in acquisition.

Document	Date
WW-P-541/4	16 April 1990
WW-P-541/5	16 April 1990
WW-P-541/8	16 April 1990

Custodians:

Army - CR4
Navy - YD
Air Force - 99

Preparing activity:

DLA-IS

AMSC N/A

FSC 4510

DISTRIBUTION STATEMENT A. Approved for public release; distribution is unlimited.

FEDERAL SPECIFICATION SHEET
PLUMBING FIXTURES (LAVATORIES)
(DETAIL SPECIFICATION)

This amendment, which forms a part of WW-P-541/4B, dated August 1, 1980, is approved by the Commissioner, Federal Supply Service, General Services Administration, for the use of all Federal Agencies.

Page 4

Paragraph 3.1

CHANGE : Sentence to read: "Materials and components shall conform, as applicable, to ASME A112.19.1M, ANSI A112.19.2M, ASME A112.19.3H, ANSI A112.19.4M, ANSI 2124.3, and the basic specification WW-P-541/GEN."

MILITARY INTERESTS:

Custodians

Army - ME
Navy - YD
Air Force - 99

Review Activity

DLA - CS

User Activities

Army - CE
Navy - MC, MS

CIVIL AGENCY COORDINATING ACTIVITIES:

DOE
GSA - FSS
HUD - HCC

PREPARING ACTIVITY:

Navy - YD

Project 4510-0249

FSC 4510

DISTRIBUTION STATEMENT A. Approved for public release; distribution is unlimited.

WW-P-541/4B
August 1, 1980
SUPERSEDING
Fed. Spec. WW-P-541/4A
October 12, 1971

FEDERAL SPECIFICATION SHEET

PLUMBING FIXTURES (LAVATORIES)
(DETAIL SPECIFICATION)

This specification forms a part of the latest issue of
Federal Specification WW-P-541/GEN.

1. SCOPE AND CLASSIFICATION

1.1 Scope. This specification covers specific requirements for lavatories.

1.2 Classification.

1.2.1 Types. Lavatories furnished under this specification sheet shall be
of the types indicated in tables I through V.

1.2.2 Definitive part number (DPN). Lavatories covered by this
specification shall be identified by a DPN. This part number is intended for
cataloging and ordering purposes; it is not intended for surface printing on
the lavatories. The DPN shall consist of the Federal specification symbol
plus the specification part number (SPN) (see tables I through V). The DPN
shall be written as indicated below (see 6.1 and 6.4).

DPN _____	<u>wwP541/4</u>	<u>XXXXX</u>
Specification sheet identification _____ for fixture required		
SPN _____		

TABLE I. Enameled cast iron lavatory identification (100 series SPN).

Laboratory type	Nominal size (inches)	SPN
Flat rim with ledge- rectangular, See figure 1	20 x 18	100
Flat rim with ledge-round. See figure 2	18 in diameter 19 in diameter	101 102
Flat rim with ledge-oval, See figure 3	19-1/4 X 16-1/4	103
Self rimming - rectangular. See figure 1	21 x 19	104
Self rimming - round. See figure 2	19 in diameter	105
Self rimming - oval. See figure 3	20-1/4 X 17-1/4	106
Straight-front apron straight back. See figure 4	19 x 17 20 X 18 21 X 18 22 x 19	107 108 109 110
Shelf-back with apron. See figure 5	19 x 17 22 x 19 24 X 18	111 112 113

TABLE II. Vitreous china lavatory identification (200 series SPN).

Lavatory type	Nominal size (Inches)	Notes	SPN
Flat rim - rectangular. See figure 1	20 X 18 20 x 19		200 201
Flat rim - round. See figure 2	18 in diameter		202
Flat rim - oval. See figure 3	20 x 17 19 x 15 19 X 16		203 204 205
Self rimming - rectangular. See figure 1	22 x 19 21 x 19 19 X 16		206 207 208

TABLE 11. ~~Vitreous china laboratory~~ "identification (200 series SPN) cont'd.

Lavatory type	Nominal size (inches)	Notes	SPN
	18 in diameter		209
Self rimming - round See figure 2	19 in diameter		210
	20 x 17		211
Self rimming - oval See figure 3	19 x 15		212
Corner, shelf-back see figure 8	17 x 17	For china leg, add CL to SPN e.g., 213 CL	213
	20 X 18	For china leg, add CL to SPN e.g., 214 CL	214
Straight-front apron, straight-back See figure 4	24 x 20	For china leg, add CL to SPN e.g., 215 CL	215
	24 x 21	For china leg, add CL to SPN e.g., 216 CL	216
	19 x 17	For metal leg, add ML to SPN e.g., 217 ML	217
Straight-front apron, ledge-back See figure 6	20 x 18	For metal leg, add ML to SPN e.g., 218 ML	218
	22 X 18	For metal leg, add ML to SPN e.g., 219 ML	219
	24 X 20	For metal leg, add ML to SPN e.g., 220 ML	220
	19 x 17	For metal leg, add ML to SPN e.g., 221 ML	221
Straight-front apron! shelf-back See figure 5	20 X 18	For metal leg, add ML to SPN e.g., 222 ML	222
	22 X 18	For metal leg, add ML to SPN e.g., 223 ML	223
	24 X 20	For metal leg, add ML to SPN e.g., 224 ML	224
	20 X 18	For metal leg, add ML to SPN for china leg add CL to SPN e.g., 225 ML or 225 CL	225
Slab type, See figure 7	24 X 20	For metal leg, add ML to SPN, for china leg add CL to SPN e.g., 226 ML or 226 CL	226
	24 X 21	For metal leg, add ML to SPN, for china leg add CL to SPN e.g., 227 ML Or 227 CL	227

70
—

TABLE III: Stainless steel lavatory identification (300 series SPN) .

Lavatory type	Nominal size (inches)	SPN
self-rimming with ledge, rectangular, See figure 1	20 x 18	300
Self-rimming with ledge, round. See figure 2	18 in diameter 19 in diameter	301 302
Self-rimming with ledge, oval. See figure 3	20 x 17	303

TABLE IV. Porcelain enameled formed steel lavatory identification (400 series SPN) .

Lavatory type	Nominal size (inches)	SPN
Flat rim with ledge, rectangular. See-figure 1	19 X 16 20 X 18	400 401
Self-rimming with ledge, rectangular? See figure 1	20 x 18	402
Flat rim with ledge, round. See figure 2	18 in diameter 19 in diameter	403 404
Flat rim with ledge, oval. See figure 3	19 X 16 20 x 17	405 406
Self-rimming with ledge, round See figure 2	18 in diamter 19 in diameter	407 408
Self-rimming with ledge, oval. See figure 3	20 x 17	409

TABLE V. Plastic lavatory identification (500 series SPN) .

Lavatory type	Nominal size (inches)	SPN
Self-rimming with ledge, round. See figure 2	18 in diameter	500
Self-rimming: with ledge; oval, See figure 3	20 x 17	501

2. APPLICABLE" DOCUMENTS

2.1 Latest issue of WW-P-541/GEN and documents referenced therein.

3. REQUIREMENTS

3.1 Materials and components. Materials and components shall conform, as applicable, to ANSI A112.19.LM through A112.19.4, 2124.3, and the basic specification 'W-P-541/GEN.

3.2 Color Lavatories (except stainless steel) shall **be** white in color
(see 6.3)

4 QUALITY ASSURANCE PROVISIONS

4.1 Responsibility for inspection (see WW-P-541/GEN).

4.2 Quality conformance inspection (see WW-P-541/GEN).

5. PREPARATION FOR DELIVERY (see WW-P-541/GEN).

6. NOTES

6.1 Ordering data: Purchasers should select the preferred options permitted herein, and include the following information in procurement documents:

- (a) Title, number, and date of this specification.
- (b) Definitive part number (see 1.2.2).

6.2 Figures. Figures contained herein are for the convenience of identification of lavatory types. They are not intended to preclude the purchase of lavatories of similar design which are in accordance with the requirements of this specification. Purchasers requiring more detailed figures should consult the applicable ANSI standards.

6.3 Colors. Hue and color of lavatories may vary from one manufacturer to another, purchasers should consult manufacturer's literature prior to placing orders for colored fixtures. Colors other than white shall be specified in contract document.

6.4 Example of DPN:

DPN characteristics _____	WWP541/4	213CL
Plumbing fixture (lavatories) _____		
SPN - type, style, and class of lavatory (see table II) _____		

MILITARY CUSTODIANS:

Army-ME
Navy - YD
Air Force - **99**

CIVIL AGENCY COORDINATING ACTIVITIES

DOE - AEC
GSA - FSS
HUD - TCS

Review activity:

DLA - CS

Preparing activity:

Navy - YD

User activities:

Army-CE
Navy - MC MS

Project No. 4510-0171-4

Orders for this publication are to be placed with General Services Administration, acting as an agent for the Superintendent of Documents. See section 2 of this **specification to** obtain extra copies and other documents referenced herein.

WW-P-541/4B

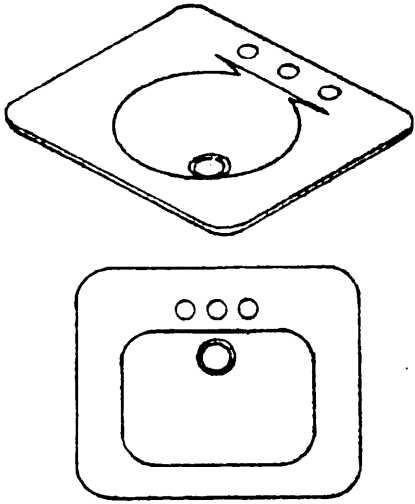

FIG. 1. RECTANGULAR FLAT-RIM LAVATORIES.

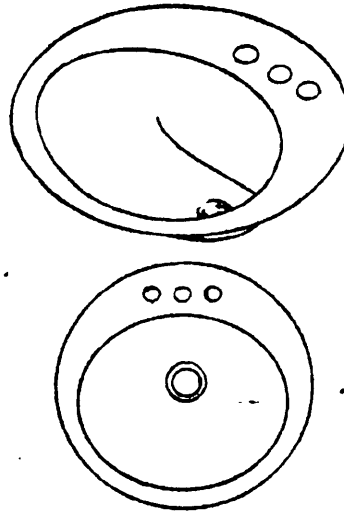

FIG. 2. ROUND FLAT-RIM LAVATORIES.

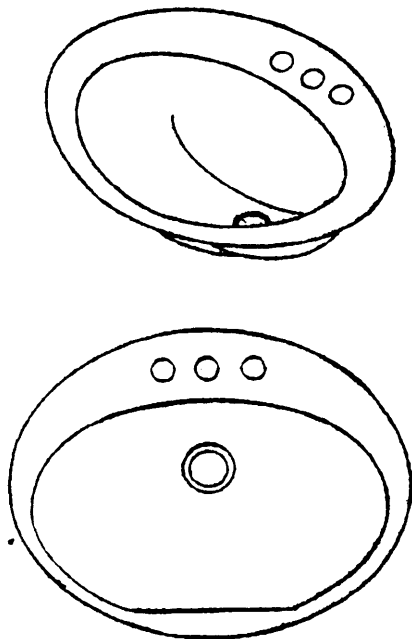

FIG. 3. OVAL FLAT-RIM LAVATORIES.

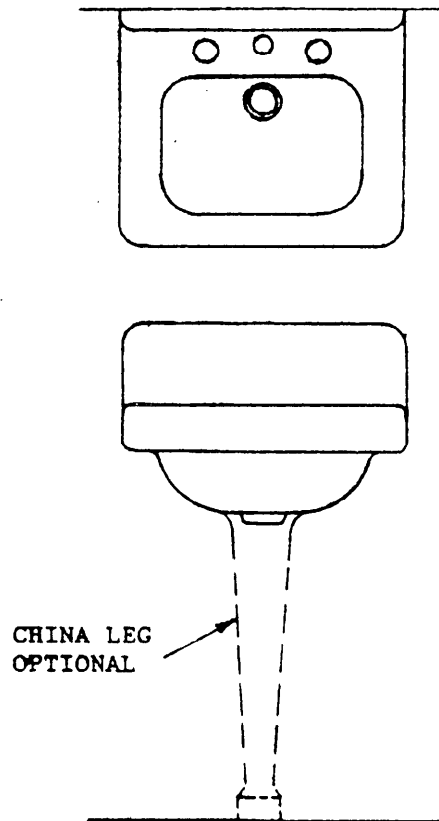

FIG. 4. LAVATORIES WITH STRAIGHT BACKS.

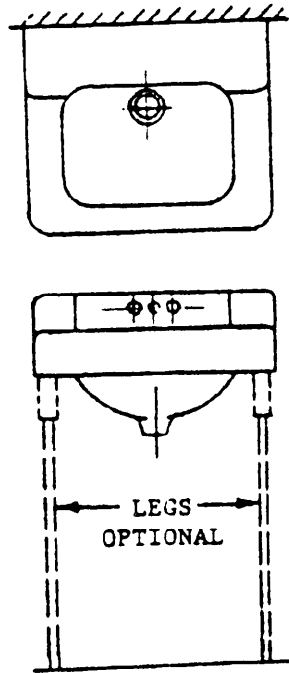

FIG. 5. SHELF-BACK LAVATORIES.

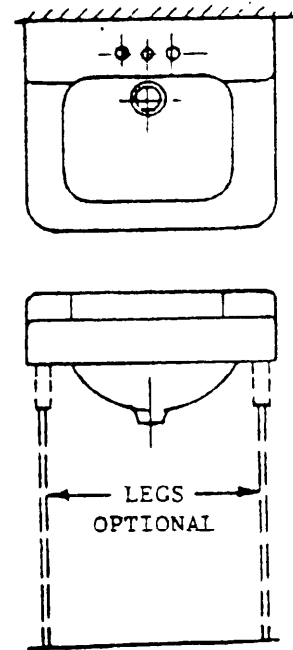

FIG. 6. LEDGE-BACK LAVATORIES.

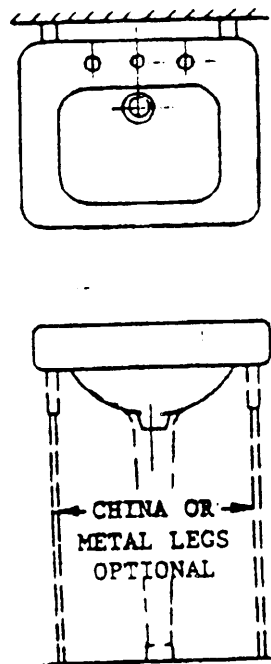

FIG. 7. SLAB-TYPE LAVATORIES.

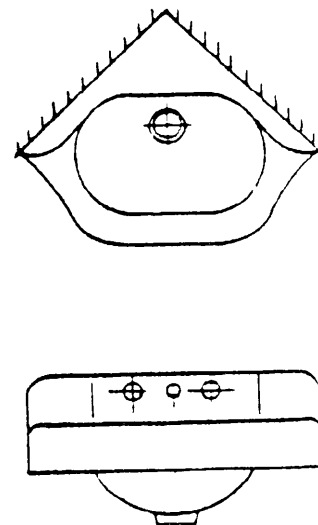

FIG. 8. CORNER LAVATORIES WITH SHELF-BACK.