

UNIFIED FACILITIES CRITERIA (UFC)

POV SITE CIRCULATION AND PARKING



APPROVED FOR PUBLIC RELEASE; DISTRIBUTION UNLIMITED

UNIFIED FACILITIES CRITERIA (UFC)

POV SITE CIRCULATION AND PARKING

Any copyrighted material included in this UFC is identified at its point of use. Use of the copyrighted material apart from this UFC must have the permission of the copyright holder.

U.S. ARMY CORPS OF ENGINEERS (Preparing Activity)

NAVAL FACILITIES ENGINEERING COMMAND

AIR FORCE CIVIL ENGINEER SUPPORT AGENCY

Record of Changes (changes are indicated by \1\ ... /1/)

Change No.	Date	Location
1	March 2010	ADA to ABA Accessibility Standards for DoD Facilities throughout.

This UFC supersedes TI 804-11, dated 30 November 1998. The format of this UFC does not conform to UFC 1-300-01; however, the format will be adjusted to conform at the next revision. The body of this UFC is the previous TI 804-11, dated 30 November 1998.

FOREWORD

Change 1, March 2010

v1\

The Unified Facilities Criteria (UFC) system is prescribed by MIL-STD 3007 and provides planning, design, construction, sustainment, restoration, and modernization criteria, and applies to the Military Departments, the Defense Agencies, and the DoD Field Activities in accordance with [USD\(AT&L\) Memorandum](#) dated 29 May 2002. UFC will be used for all DoD projects and work for other customers where appropriate. All construction outside of the United States is also governed by Status of forces Agreements (SOFA), Host Nation Funded Construction Agreements (HNFA), and in some instances, Bilateral Infrastructure Agreements (BIA.) Therefore, the acquisition team must ensure compliance with the more stringent of the UFC, the SOFA, the HNFA, and the BIA, as applicable.

UFC are living documents and will be periodically reviewed, updated, and made available to users as part of the Services' responsibility for providing technical criteria for military construction. Headquarters, U.S. Army Corps of Engineers (HQUSACE), Naval Facilities Engineering Command (NAVFAC), and Air Force Civil Engineer Support Agency (AFCESA) are responsible for administration of the UFC system. Defense agencies should contact the preparing service for document interpretation and improvements. Technical content of UFC is the responsibility of the cognizant DoD working group. Recommended changes with supporting rationale should be sent to the respective service proponent office by the following electronic form: [Criteria Change Request \(CCR\)](#). The form is also accessible from the Internet sites listed below.

UFC are effective upon issuance and are distributed only in electronic media from the following source:

- Whole Building Design Guide web site <http://dod.wbdg.org/>.

Hard copies of UFC printed from electronic media should be checked against the current electronic version prior to use to ensure that they are current.

AUTHORIZED BY:



DONALD L. BASHAM, P.E.
Chief, Engineering and Construction
U.S. Army Corps of Engineers



DR. JAMES W. WRIGHT, P.E.
Chief Engineer
Naval Facilities Engineering Command

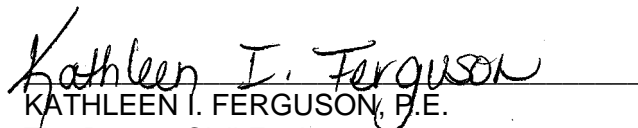

KATHLEEN I. FERGUSON, P.E.
The Deputy Civil Engineer
DCS/Installations & Logistics
Department of the Air Force



Dr. GET W. MOY, P.E.
Director, Installations Requirements and
Management
Office of the Deputy Under Secretary of Defense
(Installations and Environment)

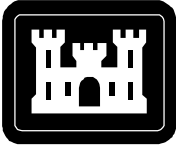

**US Army Corps
of Engineers®**

TI 804-11
30 November 1998

Technical Instructions

Design for Non-organizational or Privately Owned Vehicle (POV) Site Circulation and Parking

**Headquarters
U.S. Army Corps of Engineers
Engineering and Construction Division
Directorate of Military Programs
Washington, DC 20314-1000**

TECHNICAL INSTRUCTIONS

**DESIGN FOR NON-ORGANIZATIONAL OR PRIVATELY OWNED VEHICLE (POV) SITE
CIRCULATION AND PARKING**

Any copyrighted material included in this document is identified at its point of use.
Use of the copyrighted material apart from this document must have the permission of the
copyright holder.

Approved for public release; unlimited distribution.

Record of Changes (changes indicated by \1\ . . ./1/.)
No. Date Page

FOREWORD

These technical instructions (TI) provide design and construction criteria and apply to all U.S. Army Corps of Engineers (USACE) commands having military construction responsibilities. TI will be used for all Army projects executed for other military services or work for other customers where appropriate.

TI are living documents and will be periodically reviewed, updated, and made available to users as part of the HQUSACE responsibility for technical criteria and policy for new military construction. CEMP-ET is responsible for administration of the TI system; technical content of TI is the responsibility of the HQUSACE element of the discipline involved. Recommended changes to the TI, with rationale for the changes, should be sent to HQUSACE, ATTN: CEMP - ET, Massachusetts Ave., NW, Washington, D. C. 20314 -1000.

TI are effective upon issuance. TI are distributed only in electronic media through the TECHINFO Internet site <http://www.hnd.usace.army.mil/techunfo/index.htm> and the Construction Criteria Base (CCB) system maintained by the National Institute of Building Sciences at Internet site <http://www.nibs.org/ccb/>. Hard copies of these instructions produced by the user from the electronic media should be checked against the current electronic version prior to use to assure that the latest instructions are used.

FOR THE COMMANDER:

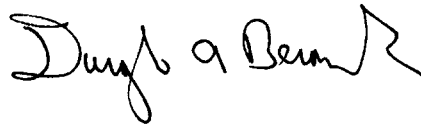

DWIGHT A. BERANEK, P.E.
Chief, Engineering and Construction Division
Directorate of Military Programs

DESIGN FOR NON-ORGANIZATIONAL OR PRIVATELY OWNED VEHICLE (POV)
SITE CIRCULATION AND PARKING

Table of Contents

	Page
CHAPTER 1 INTRODUCTION	
Paragraph 1-1. PURPOSE AND SCOPE.....	1
1-2. APPLICABILITY.....	1
1-3. REFERENCES	1
1-4. DESIGN TEAM.....	1
CHAPTER 2 DESIGN FOR NON ORGANIZATIONAL OR PRIVATELY OWNED VEHICLE SITE CIRCULATION AND PARKING	
Paragraph 2-1. GENERAL.....	2
2-2. DESIGN VEHICLES.....	2
2-3. ACCESS AND SERVICE DRIVES.....	3
2-4. PARKING AREAS.....	5
2-5. PETROLEUM, OIL AND LUBRICATION (POL) PARKING AREAS.....	8
2-6. SPECIAL CIRCULATION AREAS.....	8
2-7. MITIGATING VEHICULAR IMPACT.....	11
APPENDIX A REFERENCES.....	A-1

FIGURES

Figure	Title	Page
2-1	Standard Passenger Car Turning Path and Radius	12
2-2	Safe Sight Distances	13
2-3	Standard Throat Dimensions	13
2-4	Standard Parking Configurations	14
2-5	Typical Parking Islands and Medians	15
2-6	Parking Lot Landscaping Recommendations	16
2-7	Typical Small 90-degree Parking Lot Grading Plan	17
2-8	Typical Large 90-degree Parking Lot Grading Plan	18
2-9	Typical Gate Areas	19
2-10	Typical Drop-off Area	20
2-11	Typical Loading Area for Medium Size Trucks	21
2-12	Typical Dumpster Location and Access	22
2-13	Typical Dumpster Pad Layout	23
2-14	Motorcycle Parking	24
2-15	Screening Parking Areas	25

TABLES

Table	Title	Page
2-1	Dimensions for Design Vehicles	2
2-2	Minimum Turning Radii for Design Vehicles	3
2-3	Minimum Driveway Spacing for Streets serving more than 5,000 Vehicles per Day	3
2-4	Minimum Sight Distances	4
2-5	Parking Island Widths	7

CHAPTER 1

INTRODUCTION

1-1. **PURPOSE AND SCOPE.** This document provides guidance for designing parking areas and other facilities required for on-site vehicular circulation and stationing. These instructions define the non-organizational or privately owned vehicle passenger car and light truck design vehicles and set guidelines for determining the size and layout to include grading, drainage and circulation.

1-2. **APPLICABILITY.** These instructions are applicable to all USACE elements involved with onsite vehicular circulation and the preparation of design drawings and specifications for parking and circulation facilities.

1-3. **REFERENCES.** Appendix A contains a list of references used in these instructions.

1-4. **DESIGN TEAM.** The design of on-site circulation and parking is the responsibility of an interdisciplinary team of design professionals (ER 1110 -1-8152). This multi-professional approach to the planning process helps assure that all aspects of the man-made and natural characteristics of the area being planned are properly and thoroughly considered. Plans are prepared that provide a comprehensive solution to the program requirements addressing environmental assessment of actions, design quality and economic efficiency. Identify the interdisciplinary team at the beginning of the planning process so that its expertise can be applied from the outset. The team members and the team leader will be determined by the functional requirements of the project. There are typically four major components of a planning and design team: landscape architecture, land planning, civil engineering, and architecture. The landscape architect may take the lead role because of the expertise required in design and analysis for circulation and parking. Other professionals such as traffic and civil engineers, geologists, and historic preservationists may be included in the design process as warranted by specific conditions.

CHAPTER 2
DESIGN FOR NON-ORGANIZATIONAL OR PRIVATELY OWNED VEHICLE
SITE CIRCULATION AND PARKING

2-1. GENERAL. This chapter provides the criteria, guidelines, and standards for determining the design vehicle, turning radii, circulation functional relationships, and parking layout. The chapter covers access and service drives; parking areas; and special vehicle use areas including gateways, drop-offs, dumpsters, deliveries, and drive-in facilities. This chapter also addresses methods for mitigating the visual impact of parking and other vehicle use areas.

2-2. DESIGN VEHICLES. The American Association of State Highway and Transportation Officials (AASHTO) places vehicles into two general classes: passenger cars and trucks. The passenger car class includes passenger cars, and light delivery trucks such as vans and pick-ups. The truck class includes single-unit trucks, recreation vehicles, buses, trucks semi-tractor trailer combinations, and trucks or truck tractors with semi-trailers in combination with full trailers (AASHTO, 1984). The design vehicles for this section include both the passenger car and the truck classification.

a. Vehicle Dimensions and Turning Radii. Design circulation and parking to provide the maneuverability and traffic safety required by the vehicles that utilize the facility. Table 2-1 lists dimensions for some of the more common vehicles. Table 2-2 lists minimum turning radii for the same vehicles. AASHTO provides an expanded list with additional dimensions and information.

b. Design Vehicle Template. The AASHTO passenger car is equivalent to a non-organizational or privately owned vehicle. Figure 2-1 illustrates a template showing the turning paths and radii of a passenger car. Templates showing the turning movements for other design vehicles are provided by AASHTO.

Table 2-1. Dimensions for Design Vehicles

	<i>Vehicle Dimension</i>		<i>Bumper Overhang</i>	
	<i>Width</i>	<i>Length</i>	<i>Front</i>	<i>Rear</i>
Passenger Car (P)	2.1 (7.0)	5.8 (19.0)	0.9 (3.0)	1.5 (5.0)
Single Unit Truck (SU)	2.6 (8.5)	9.2 (30.0)	1.2 (4.0)	1.8 (6.0)
Intermediate Semi-trailer (WB-40)	2.6 (8.5)	15.3 (50.0)	1.2 (4.0)	1.8 (6.0)
Large Semi-trailer (WB-50)	2.6 (8.5)	16.8 (55.0)	0.9 (3.0)	0.6 (2.0)
Single Unit Bus (BUS)	2.6 (8.5)	12.2 (40.0)	2.1 (7.0)	2.4 (8.0)
Motor Home (MH)	2.4 (8.0)	9.2 (30.0)	1.2 (4.0)	1.8 (6.0)

Table 2-2. Minimum Turning Radii for Design Vehicles

<i>Design Vehicle</i>	<i>Minimum Design Turning Radius m (ft)</i>	<i>Minimum Inside Radius m (ft)</i>
-----------------------	---	---

Passenger Car	7.3 (24.0)	4.7 (15.3)
Single Unit Truck	12.8 (42.0)	8.7 (28.4)
Intermediate Semi-trailer	12.2 (40.0)	6.1 (19.9)
Large Semi-trailer	13.7 (45.0)	6.1 (19.8)
Single Unit Bus	12.8 (42.0)	7.1 (23.2)
Motor Home	12.8 (42.0)	8.7 (28.4)

2-3. ACCESS AND SERVICE DRIVES. Design site entrances and exits, services drives, and other areas with special requirements (e.g., parking lots or loading docks) to accommodate the largest vehicle that will use the facility. This procedure should assure that traffic safety will be accommodated.

a. Spacing. Locate access drives according to the following spacing guidelines:

(1) Maintain 61 m (200 ft) or more between access drives on arterial roads. Table 2 -3 provides acceptable minimum spacing when frontage along an arterial road is limited.

Table 2-3. Minimum Driveway Spacing for Streets serving more than 5,000 Vehicles per Day.

<i>Arterial Speed kph (mph)</i>	<i>Minimum Separation m (ft)</i>
32 (20)	25.9 (85.0)
40 (25)	32 (105.0)
48 (30)	38 (125.0)
56 (35)	45.8 (150.0)
64 (40)	56.4 (185.0)
72 (45)	70.2 (230.0)
81 (50)	83.9 (275.0)

(2) Maintain a minimum spacing of 366m to 457m (1,200 to 1,500 ft) between a signaled drive and adjacent signaled intersection. If the signaled drive is a T-intersection, 183m (600 ft) is an acceptable minimum spacing when frontage is limited.

(3) Coordinate drive signals within 762m (2,500 ft) of adjacent signals.

(4) Maintain a minimum spacing of 10.5m to 15.5m (35 to 50 ft) on low-volume (5,000 vehicles per day), low-speed (48 kph (30 mph)) roads.

b. Corner Clearances. Access drives near major intersections adversely affect traffic operations. They may result in unexpected conflicts with vehicles turning at the intersection. Maintain a minimum clearance of 15.2m (50 ft) between access drives and major intersections.

c. Sight Distances. Provide safe sight distance for vehicles entering and exiting an access drive. This sight distance increases according to the design speed of the thorough road. The relationships of speed to sight distances are provided in table 2 -4 and illustrated in figure 2 -2. When a safe sight distance cannot be met, consider the following alternatives:

(1) Removal of sight obstructions.

- (2) Relocation of the access drive to a more favorable location along the access road.
- (3) Prohibition of critical movements at the access drive.
- (4) Relocation of the access drive to another access road.

Table 2-4. Minimum Sight Distances

Operating Speed (kph (mph))	32 kph (20 mph)		48 kph (30 mph)		64 kph (40 mph)		81 kph (50 mph)	
	Left m (ft)	Right m (ft)	Left m (ft)	Right m (ft)	Left m (ft)	Right m (ft)	Left m (ft)	Right m (ft)
Passenger car	64 (210)	52 (170)	99 (320)	112 (360)	167 (540)	183 (590)	279 (900)	301 (970)
Truck	112 (360)	71 (30)	161 (520)	140 (450)	285 (920)	285 (920)	468 (1510)	474 (1530)

NOTE: Sight distances are based on the following assumptions:

1. Upon turning left or right when exiting the access drive, the vehicle accelerates to the operating speed of the access road without causing approaching vehicles to reduce speed by more than 16 kph (10 mph).
2. Upon turning left when entering the access drive, the vehicle clears the near half of the access road without causing approaching vehicles to reduce speed by more than 16 kph (10 mph).
3. Turns are 90-degree.
4. The access road and the access drive are on level terrain.

d. Left turns. Prevent left turns on the through road to limit conflict under the following conditions:

- (1) Inadequate corner clearance.
- (2) Inadequate sight distance.
- (3) Inadequate driveway spacing.
- (4) Median opening too close to another median opening.

e. Entrances. Design entrances to and from access drives to include:

- (1) Minimum turning radii for the largest vehicle expected to use the site.
- (2) A minimum 3.1m (10-ft) wide traffic island where entry and exit lanes into the site are separated.
- (3) Minimum throat widths and lengths to accommodate incoming and outgoing traffic. Figure 2-3 illustrates throat dimensions.
- (4) Sufficient width to accommodate single- or double-lane traffic depending upon the design vehicle using the route.
- (5) A minimum 30.5m (100 ft) unobstructed sight distance for turns from parking lots and service drives onto the access drive.

f. Grading and Drainage. Design access drives with gradients that conform to the natural topography using commonly accepted minimum and maximum gradients. Grades and slope directions are determined utilizing the drainage requirements established in the surface water management plan prepared for the project site. TM 5-822-2 provides additional information on the grading of entrance and exit drives.

g. Pavement. TM 5-822-5 provides guidance for the design and engineering of roadway pavements.

h. Traffic Controls. The Manual on Uniform Traffic Control Devices for Streets and Highways (ANSI D 6.1e) provide information on devices to control and direct traffic.

i. Lighting. TM 5-811-1 provides guidance on roadway lighting.

2-4. PARKING AREAS. POV parking includes on-street parking, off-street parking lots, and parking structures.

a. On-street Parking. On-street parking will be limited to parallel parking spaces that include sufficient length and width to allow safe movement into and out of the space and to adequately separate the parked vehicle from the traffic lanes. Parking shall comply with the Architectural Barriers Act (ABA) Accessibility Standard for Department of Defense Facilities. /1/

b. Off-street Parking Lots. Off-street parking lots are the principal means of parking on installations.

(1) Layout. A 90-degree parking layout is preferable. Where a fast rate of turnover is expected or where required by site limitations, a 45-degree or 60-degree angle layout may be used. Figure 2-4 illustrates standard designs for 45-degree, 60-degree, and 90-degree parking lots. Design the parking layout to:

- (a) Provide parking in accordance with ABA Accessibility Standard for Department of Defense Facilities. /1/ If state requirements are more stringent, they shall be used.
- (b) Maintain two-way movement.
- (c) Avoid dead end parking lots.
- (d) Provide more than one entrance and exit for parking lots with more than 100 parking spaces.
- (e) Provide traffic breaks in aisles longer than 107m (350 ft) .
- (f) Use compact parking spaces (2.4m X 4.9m (8 ft X 16 ft)) only if recommended by a traffic impact study.
- (g) Provide curbs or a painted lines at the ends of stalls to control placement of vehicles.
- (h) Provide adequate walkway width to allow comfortable pedestrian movement in areas of bumper overhang.
- (i) Provide curb cuts for barrier-free access to sidewalks.

(j) Consider the requirements for snow removal.

(2) Islands and Medians. Locate islands at the ends of parking stalls and at the intersections of parking aisles. The islands establish turning radii for vehicular movement and protect end stalls. Turning radii to be used is based upon the largest vehicle that will utilize the parking lot. Include turning radii that is sufficient to allow safe traffic movement without conflicting with the island and/or curbing. Figure 2 -5 illustrates considerations for designing islands and medians. Consider the 1.3m (52 -in.) motorist eye level viewing height when providing shrubs and small trees. The purpose of placing plant material in islands and/or medians in the midst of parking lots it to:

- (a) Provide separation by vehicle and function.
- (b) Break up the expanse of impermeable and unshaded surface.
- (c) Provide a more pleasing visual and spatial appearance.
- (d) Preserve existing vegetation.
- (e) Consider the requirements for snow removal.

(3) Landscape Plant Material. TM 5 -803-13 provides guidance for the selection and placement of plant material. The planted area within and around a parking lot is usually based on a proportional amount of "green" space to paved area. Typically, a minimum of ten (10%) percent of the area is utilized for landscape plant material. Table 2-5 and figure 2-5 provides guidance concerning space or clearance within islands and medians to accommodate plant material and light poles. The minimum distance for pavement from existing trees is 1.2m (4 ft) or half (1/2) the distance from the tree trunk to the outer edge of the tree dripline, whichever is greater. Figure 2-6 illustrates the use of landscape plant material within a parking lot.

Table 2-5. Parking Island Widths

Minimum 1.5m (5 ft)	Grasses, Groundcovers, and Small Shrubs
Minimum 2.2m (8 ft)	Light Standards and new Medium Trees and Shrubs
Minimum 3m (10 ft)	New Large Trees and Shrubs

(4) Pedestrian Use. Islands and medians can be partially or completely paved to service pedestrian traffic. Pedestrians tend to use circulation aisles, especially if medians are not generous and do not allow for comfortable movement between vehicles. If the median is designed as a sidewalk, provide a width that allows for pedestrian movement and vehicle overhang.

(5) Grading and Drainage. Figures 2-7 and 2-8 illustrate basic principles for grading and draining parking lots. Parking lot grades and slope directions are determined utilizing the drainage requirements established in the surface water management plan prepared for the project site. Swales should be at a depth of no less than 30.5cm (12 in.). Provide positive drainage in parking lots and accomplish the following:

(a) Maintain a relatively constant grade across the lot that includes no less than the minimum slope of one (1) percent required for positive drainage to properly direct drainage to swales or to drainage inlets.

(b) Provide a maximum slope within a 90-degree parking space of five (5) percent from front to rear end and one and one-half (1 ½) percent from side to side.

(c) Provide a maximum slope within a 45-degree or 60-degree parking space of five (5) percent from front to rear end and one (1) percent from side to side.

(d) Use islands and medians to accommodate change in elevation between the access drive and parking areas or between different parking levels.

(e) Provide sheet flow drainage across small, flat parking lots into swales in surrounding grassed areas that are designed for erosion control.

(f) Control runoff with curbing that directs the runoff to the sides and corners of larger (more than 100 spaces) and/or steeper lots.

(g) Avoid channeling of sheet flow.

(h) Avoid ponding water.

(i) Avoid creation of an impoundment zone in the center of the lot.

(j) Provide sufficient spot elevations to move water off the lot.

(k) Provide adequate drainage inlets to move water off the lot.

(6) Lighting. Illuminate parking lots with uniform lighting coverage for pedestrian and vehicular safety and security. TM 5-811-1 provides guidance on lighting parking areas.

(7) Pavement Marking and Signage. The Manual on Uniform Traffic Control Devices for Streets and Highways (ANSI D 6.1e) provides guidance on pavement marking and signage.

c. Parking Structures. Parking structures are to be designed as structures with the design vehicle applied as described above.

2-5. PETROLEUM, OIL AND LUBRICATION (POL) PARKING AREAS. MIL-HDBK-1022 provides design criteria for facilities, which may support fueling activities. These facilities include operations buildings, contaminated fuel recovery systems, roads, utilities, and parking areas.

2-6. SPECIAL CIRCULATION AREAS. Circulation areas for other than normal passenger car traffic have special requirements to meet traffic safety. These areas require additional space to accommodate unusual traffic patterns and to provide greater turning radii, for maneuverability.

a. Gateways. Figure 2-9 illustrates typical low volume gate areas. Discuss design for gateways with the Provost Marshal and coordinate the requirements with the installation's physical security plan. Design considerations for gate areas include:

(1) Provide adequate width for a gatehouse, traffic island, travel lane, and pullover lane.

(2) Provide adequate length on the access drive to accommodate stacking of vehicles and to allow a transition zone into and out of the major traffic flow.

(3) Use curbs around traffic islands for vehicle control.

b. Drop-off Areas. Figure 2-10 illustrates a typical drop-off area. Design considerations for drop-off areas include:

(1) Provide for accessibility as required by \1\ABA Accessibility Standard for DoD Facilities./1/

(2) Provide adequate width and length to accommodate the safe movement of vehicles in and out of the flow of traffic.

(3) Maintain a minimum one- (1) percent grade across the area.

(4) Provide adequate area for stacking of vehicles.

c. Delivery and Service Zones. Delivery and service trucks need to access service doors in buildings. Delivery may require dock facilities, which need to accommodate the necessary maneuvering into and out of the dock. Figure 2 -11 illustrates a typical loading area for a single unit truck. Design considerations for delivery zones include:

(1) Separate service access drives from parking circulation because these functions are incompatible. Service access that is required through a parking area goes straight to and straight out of the service area as shown in figure 2 -12.

(2) On a dead-end service drive, provide the necessary turning movements (See figures 2-11 and 2-12).

(3) Provide positive drainage away from the loading dock with a minimum gradient of one (1.0) percent.

(4) Maintain a minimum one (1) percent grade or no more than three (3) percent grade to the dock.

(5) Provide for visual screening with walls, fences or plant material.

d. Dumpsters. The design of garbage and trash removal areas is controlled by the size and location of the dumpster and is coordinated with the local management company. Figure 2 - 13 illustrates a typical dumpster pad layout. Design considerations for dumpster pads include:

(1) It is preferable for trucks to maintain a forward movement through the site. Design for sanitation trucks to approach the pad in a straightforward manner, align with the dumpster, reverse away from the pad and exit forward from the site.

(2) Locate dumpsters on concrete pads.

(3) Provide positive drainage away from the pad.

(4) Screen the pad with fences, walls or plant material.

e. Drive-in Facilities. Drive-in facilities, such as banks and fast-food restaurants, require careful and clear establishment of traffic patterns and a continuous traffic flow. The standard configuration for a single- or double-service position facility does not lend itself to a two-lane approach and departure design. It usually relies on some form of loop system. Average stacking distance is recommended as 55m (180 ft). Stacking space is determined by subtracting the number served (serving time averages 2-3 minutes per customer) from the expected arrivals per 15-minute period (4-14 minutes is the average) and multiplying the difference times 6.0m (20 ft). Recommended parking for drive-in facilities is 17.5 spaces per 93.0 sq. m (1,000 sq. ft) of building area. Design considerations for drive-in facilities include:

(1) Maintain traffic lanes into and out of the drive-in windows while working with other on-site vehicular traffic flow including parking.

(2) Minimize interference with pedestrian traffic flow.

(3) Provide the recommended average stacking distance in the drive-through lanes.

(4) Provide the recommended average stacking distance on-site to prevent traffic safety conflicts with access roads.

(5) Use curb and planting islands for vehicle control.

(6) Provide adequate pavement markings.

f. Motorcycle Parking. Figure 2-14 illustrates a typical motorcycle parking area. Design considerations for motorcycle parking include:

(1) Locate parking close to building entrances.

(2) Locate parking in parking lot corners.

(3) Place parking on a concrete pad.

(4) Provide signage and pavement markings.

g. Emergency Vehicle Access. Provide for the access, circulation and parking of emergency vehicle access as required in the design requirements. These vehicles are to be provided with dedicated access drives.

2-7. MITIGATING VEHICULAR IMPACT. Circulation and parking areas consume large land areas with paved surfaces, explore all possible methods of mitigating the impact of circulation and parking areas.

a. Buffers. A recommended minimum 6m (20 ft) wide buffer strip should be provided to separate parking areas from adjacent streets. In areas of limited space provide a minimum distance of 2.4m (8 ft).

b. Topography. Design parking areas to conform to existing topography and balance the cut and fill. Where slopes are steep, provide more than one level of parking.

c. Screening. Design the parking screens to be compatible with the natural or architectural character of the site. Design the screen relative to the 1.3m (52 in) motorist eye level viewing height. Various methods of screening parking areas are illustrated in figure 2 -15. Locating parking below the grade of neighboring streets and surrounding land uses helps mitigate its visual impact. It may be impractical and unsafe to provide continuous screens around large parking areas. Selective placement of walls, fences, berms and plant material can be used to significantly reduce the impact of uninterrupted lines of vehicles. Trees, shrubs and ground cover on islands and medians further mitigate the impact of large ex penses of parking.

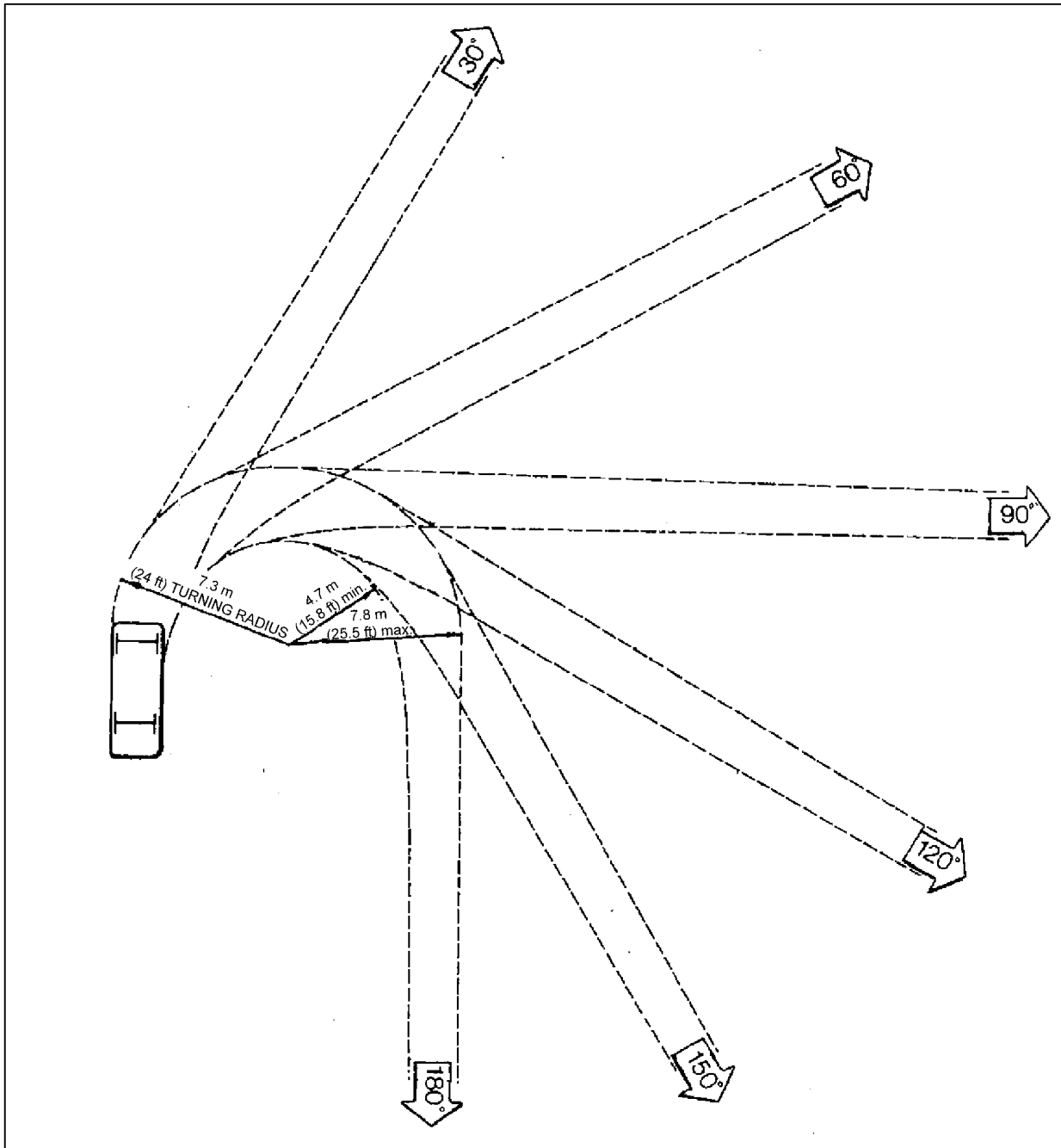

Figure 2-1. Standard passenger car turning path and radius

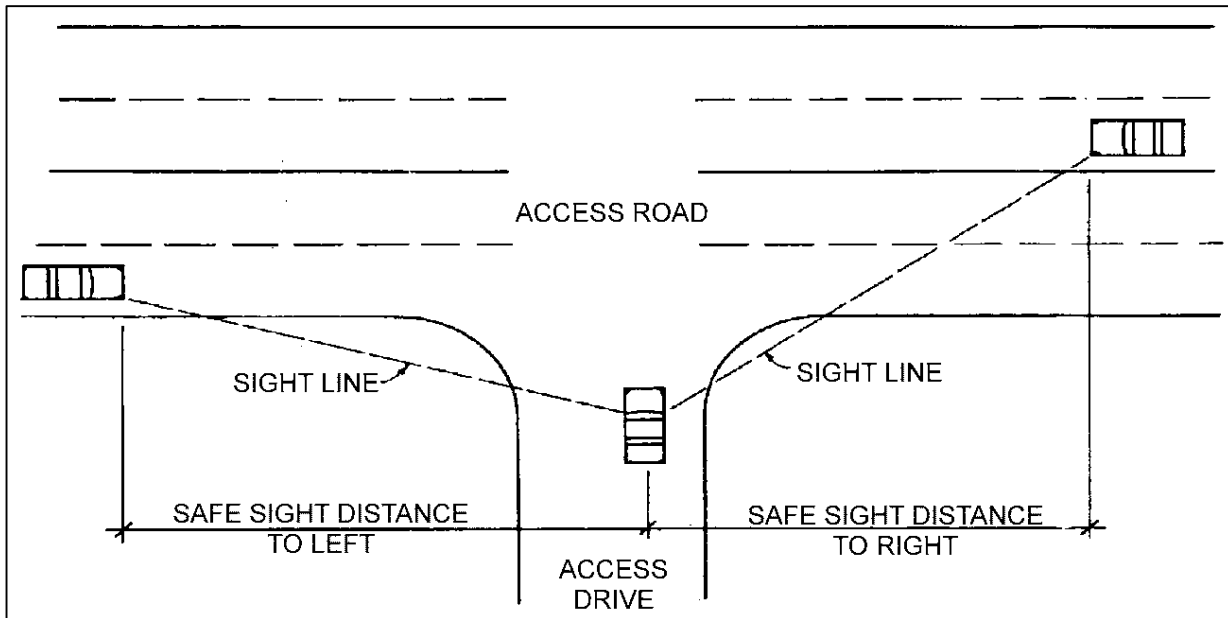

Figure 2-2. Safe sight distances

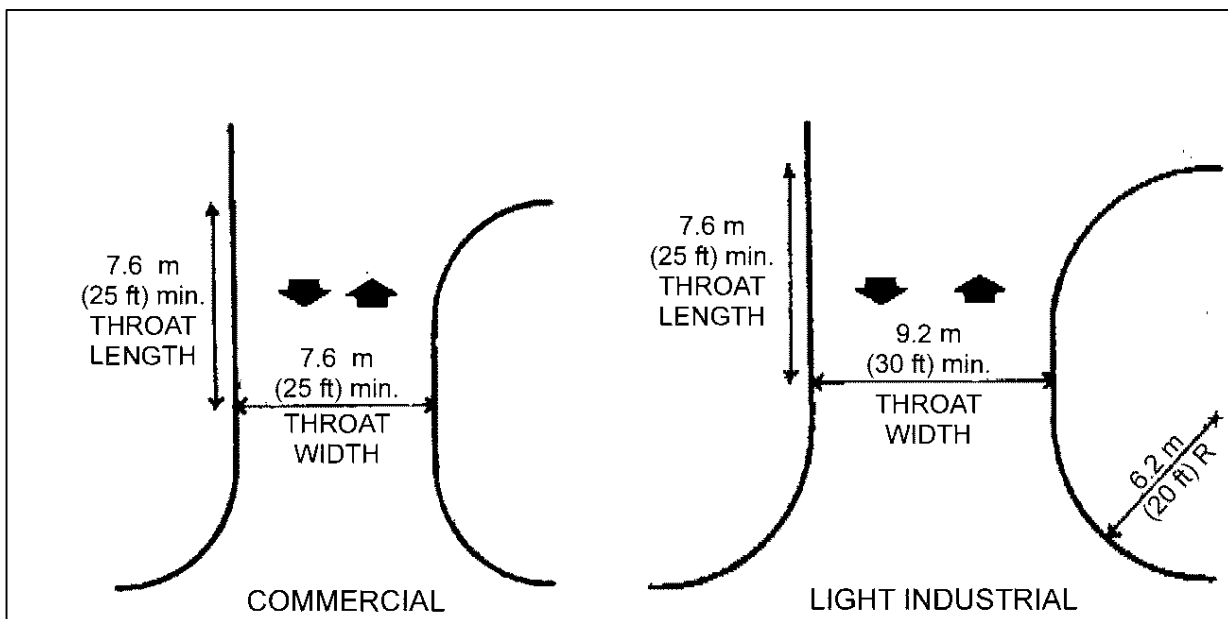

Figure 2-3. Standard throat dimensions

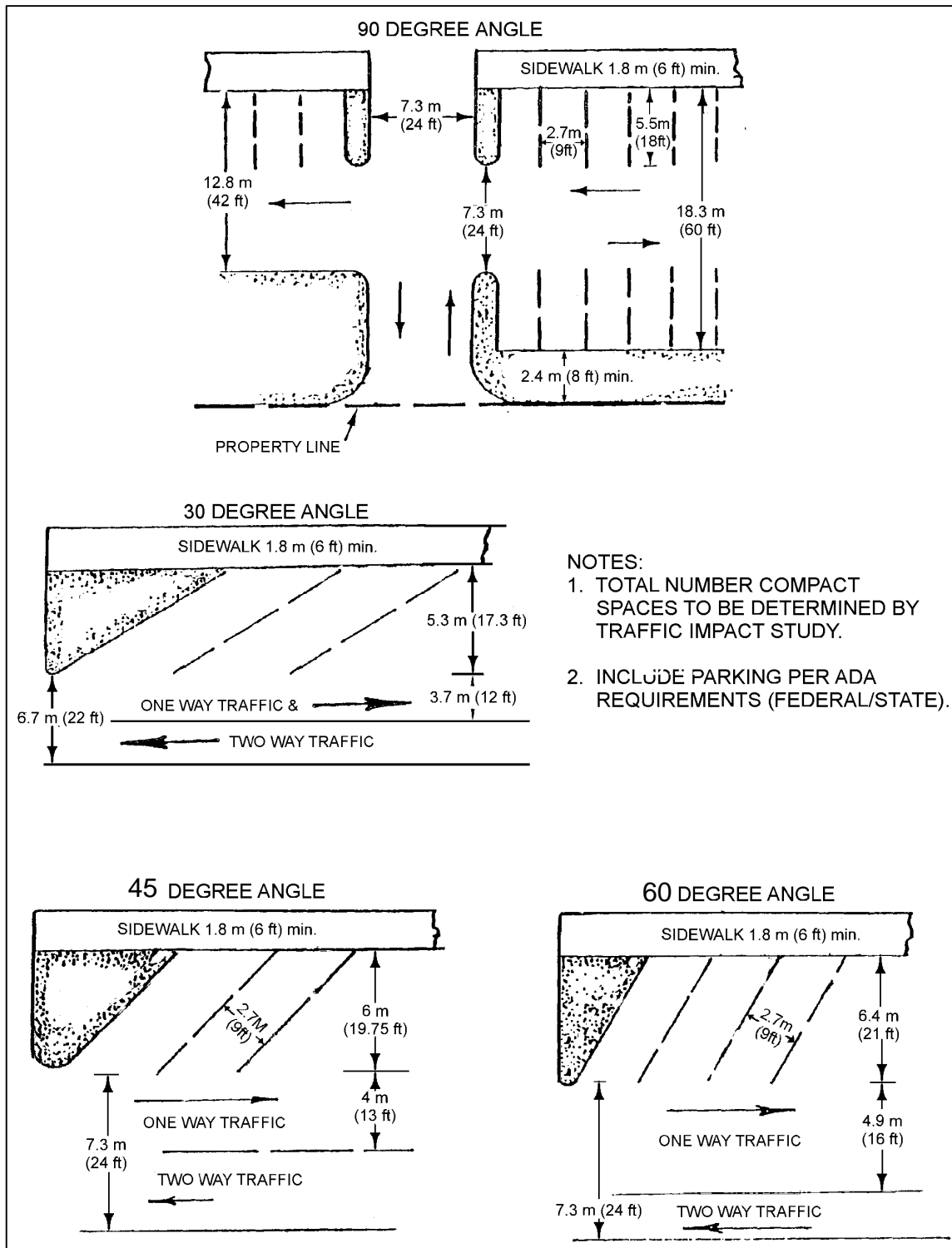

Figure 2-4. Standard parking configurations

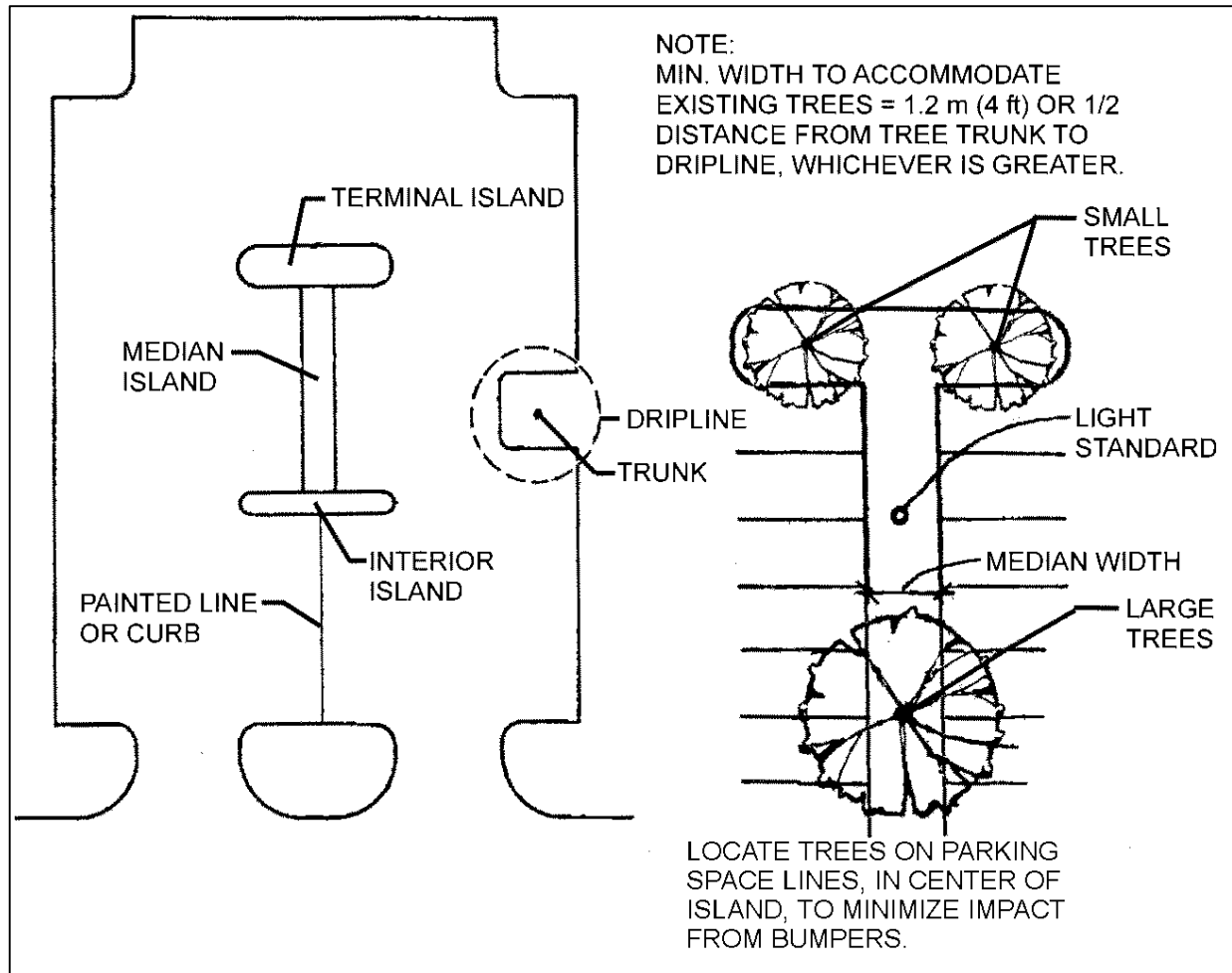

Figure 2-5. Typical parking islands and medians

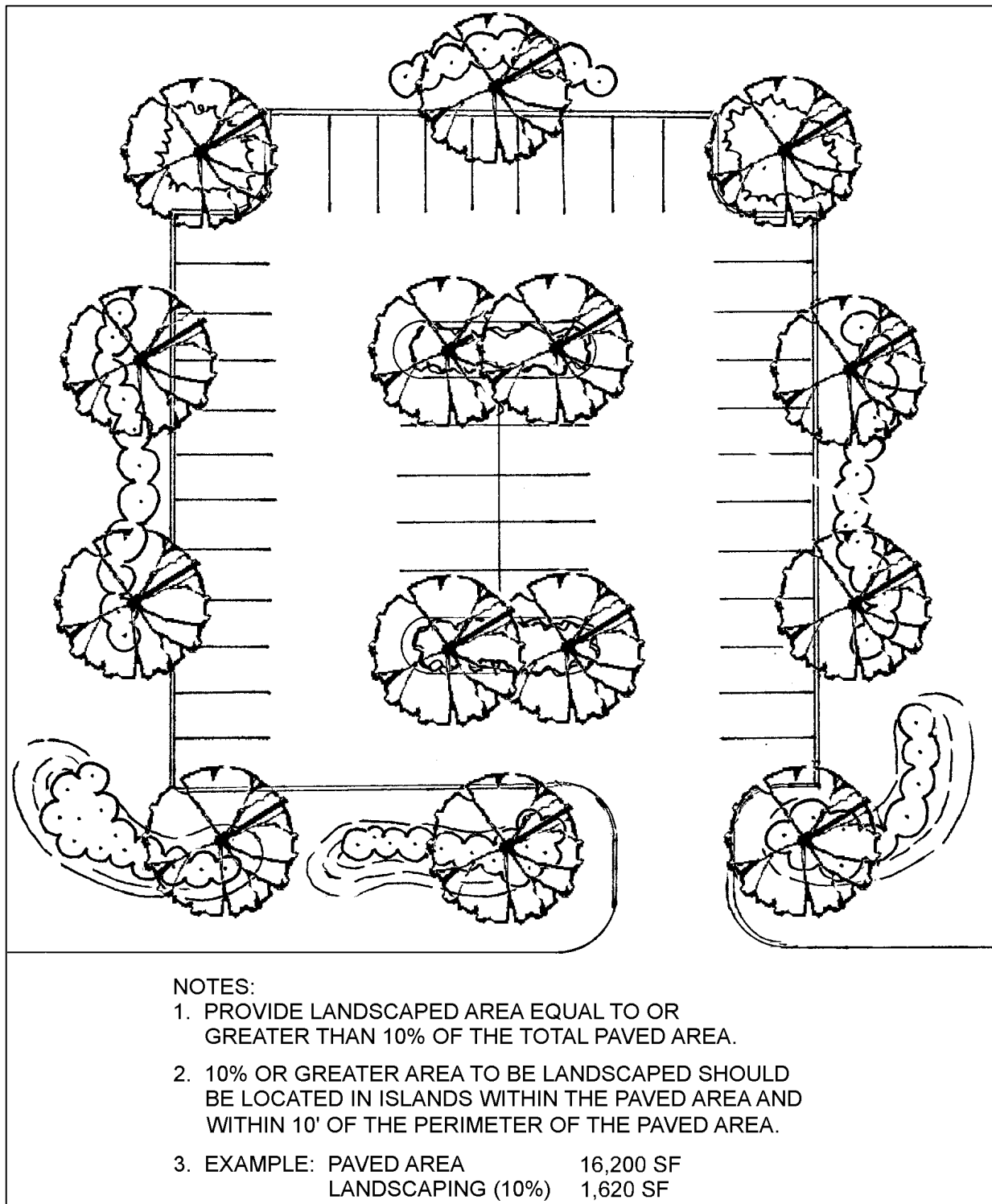

Figure 2-6. Parking lot landscaping recommendations

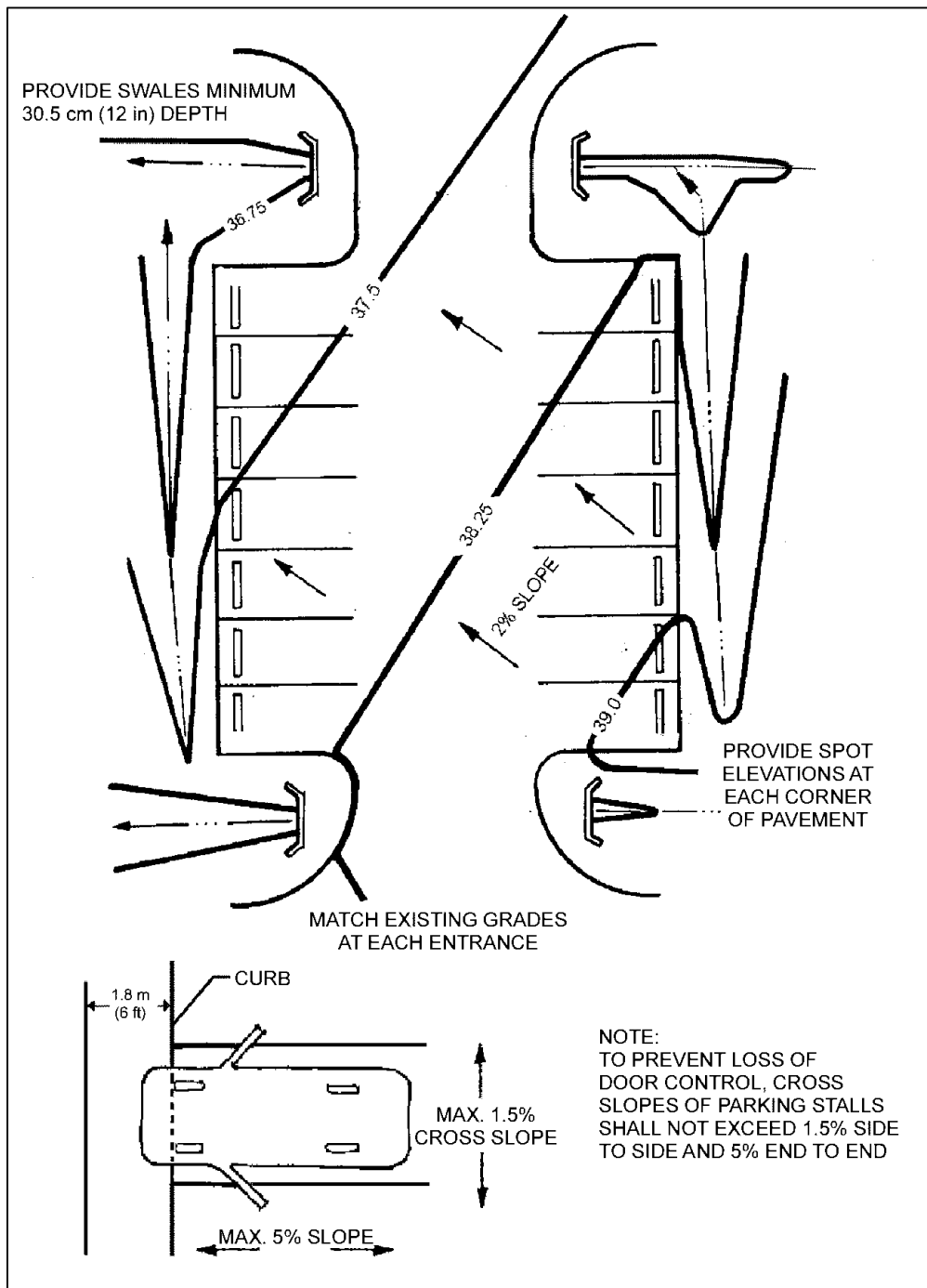

Figure 2-7. Typical small 90-degree parking lot grading plan

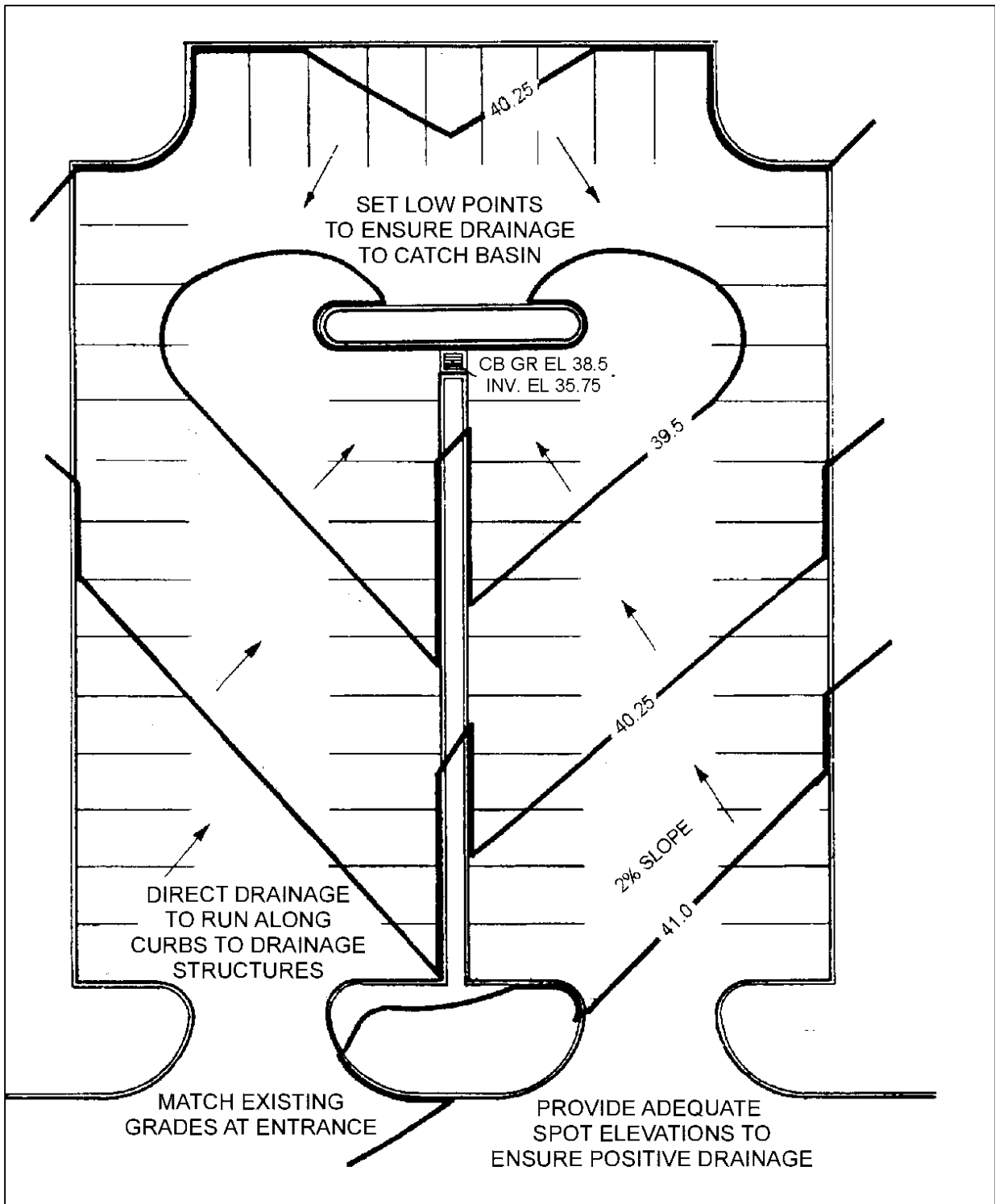

Figure 2-8. Typical large 90-degree parking lot grading plan

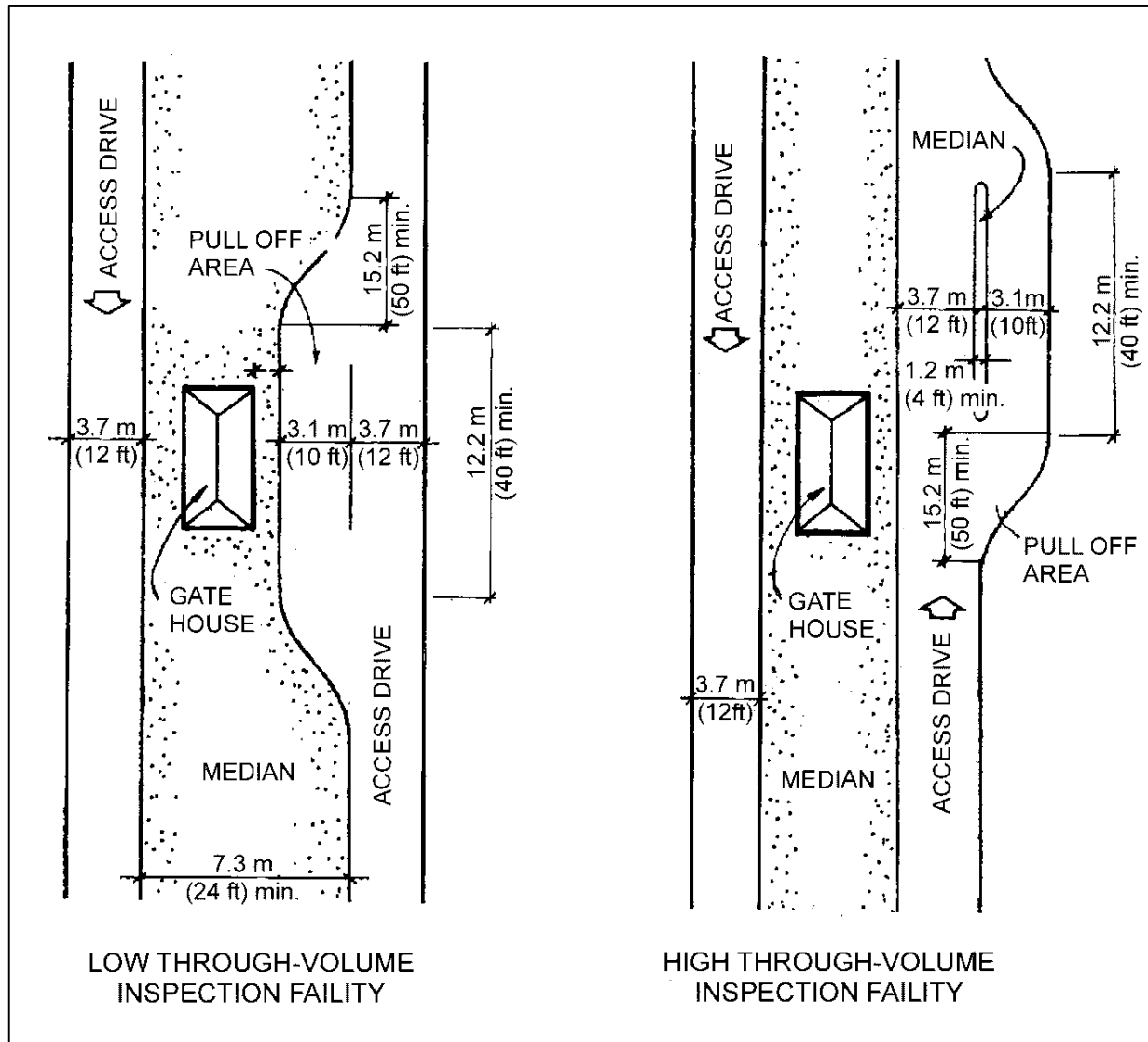

Figure 2-9. Typical gate areas

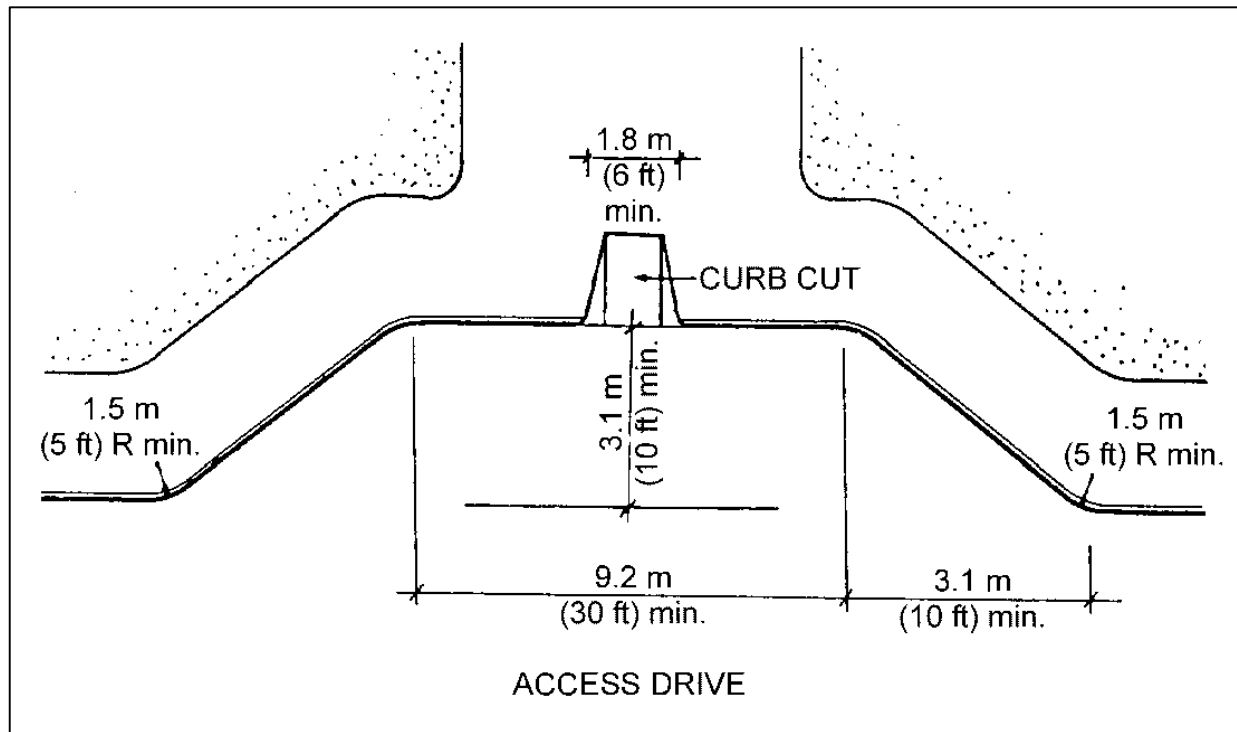

Figure 2-10. Typical drop-off area

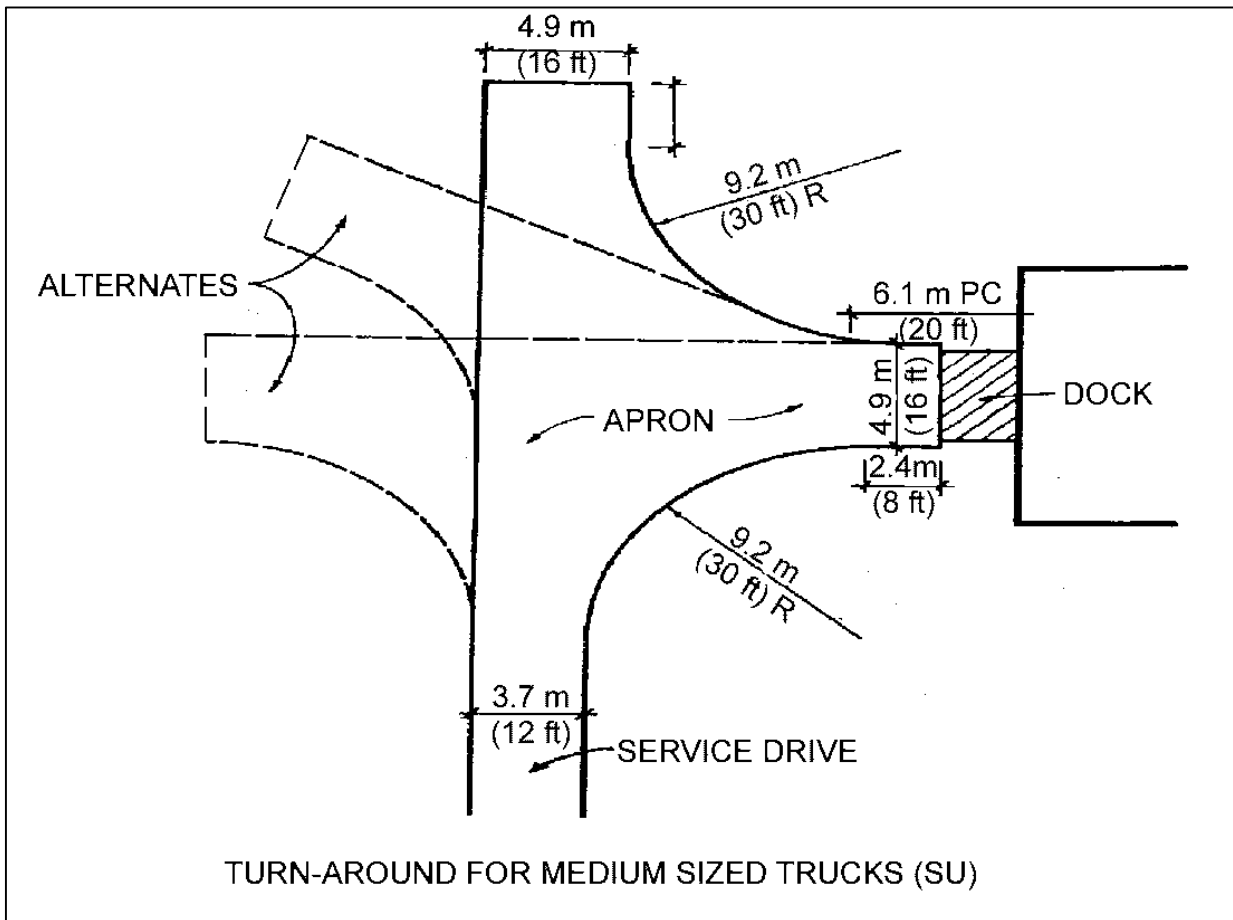

Figure 2-11. Typical loading area for medium size trucks

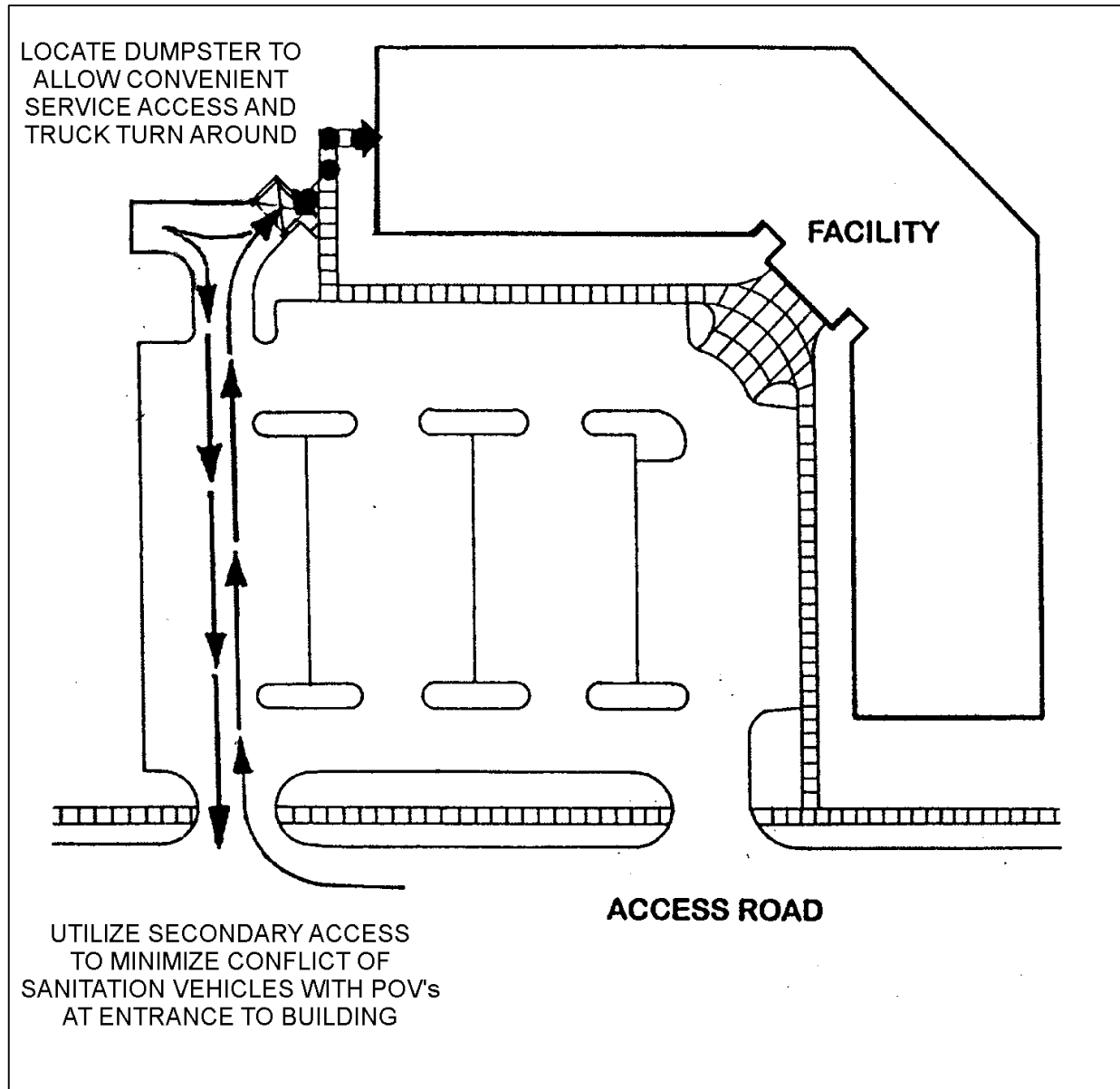

Figure 2-12. Typical dumpster location and access

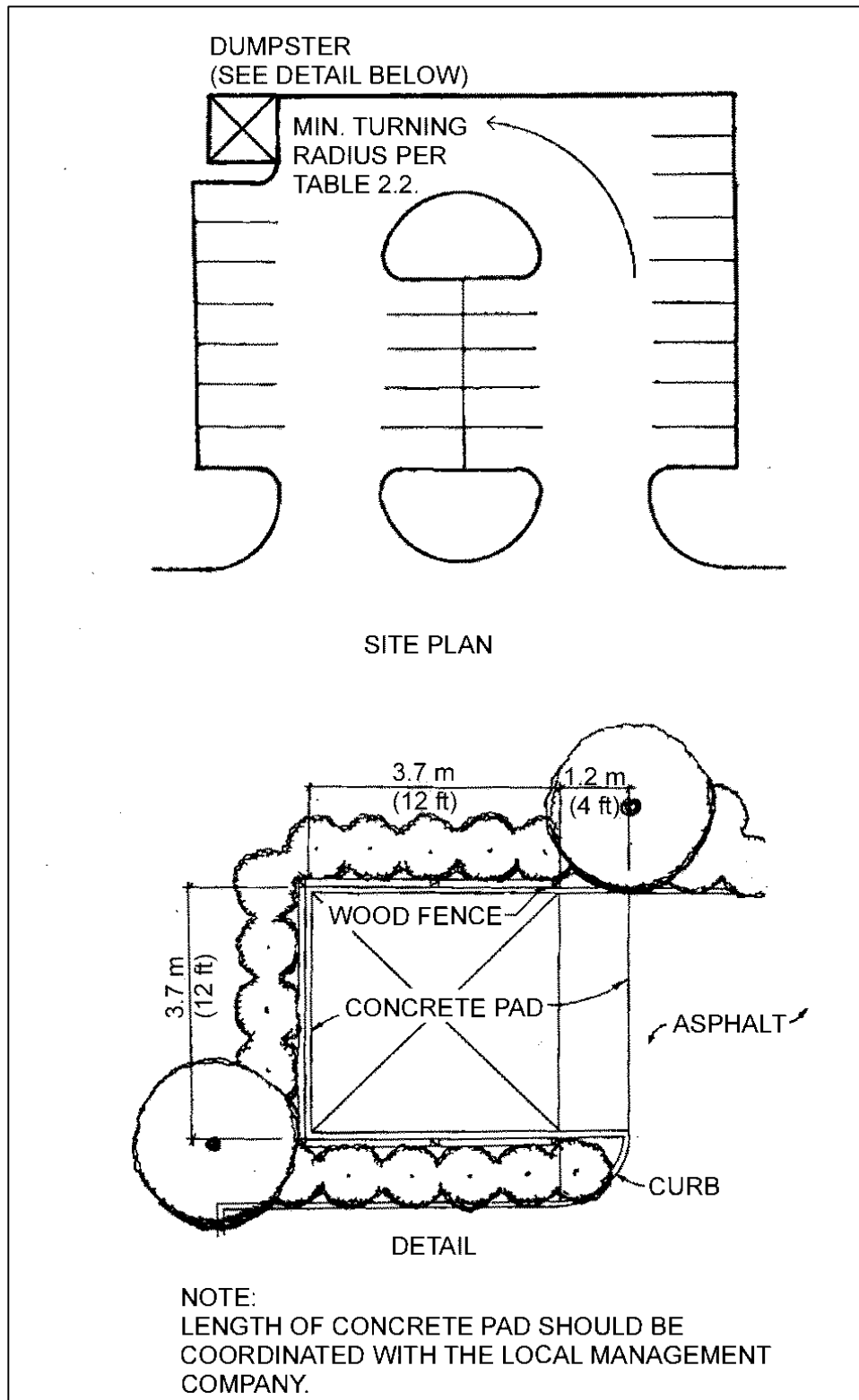

Figure 2-13. Typical dumpster pad layout

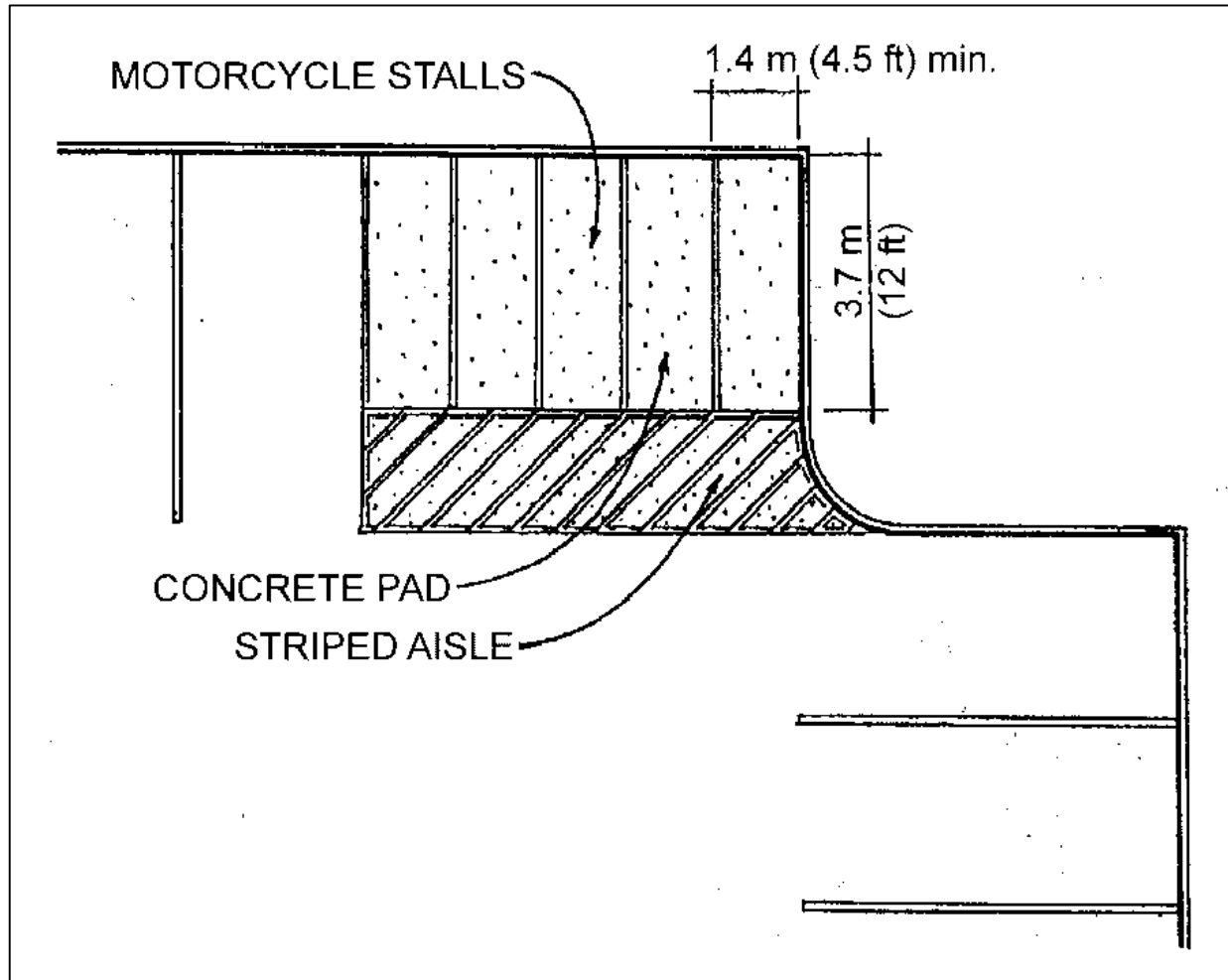

Figure 2-14. Motorcycle parking

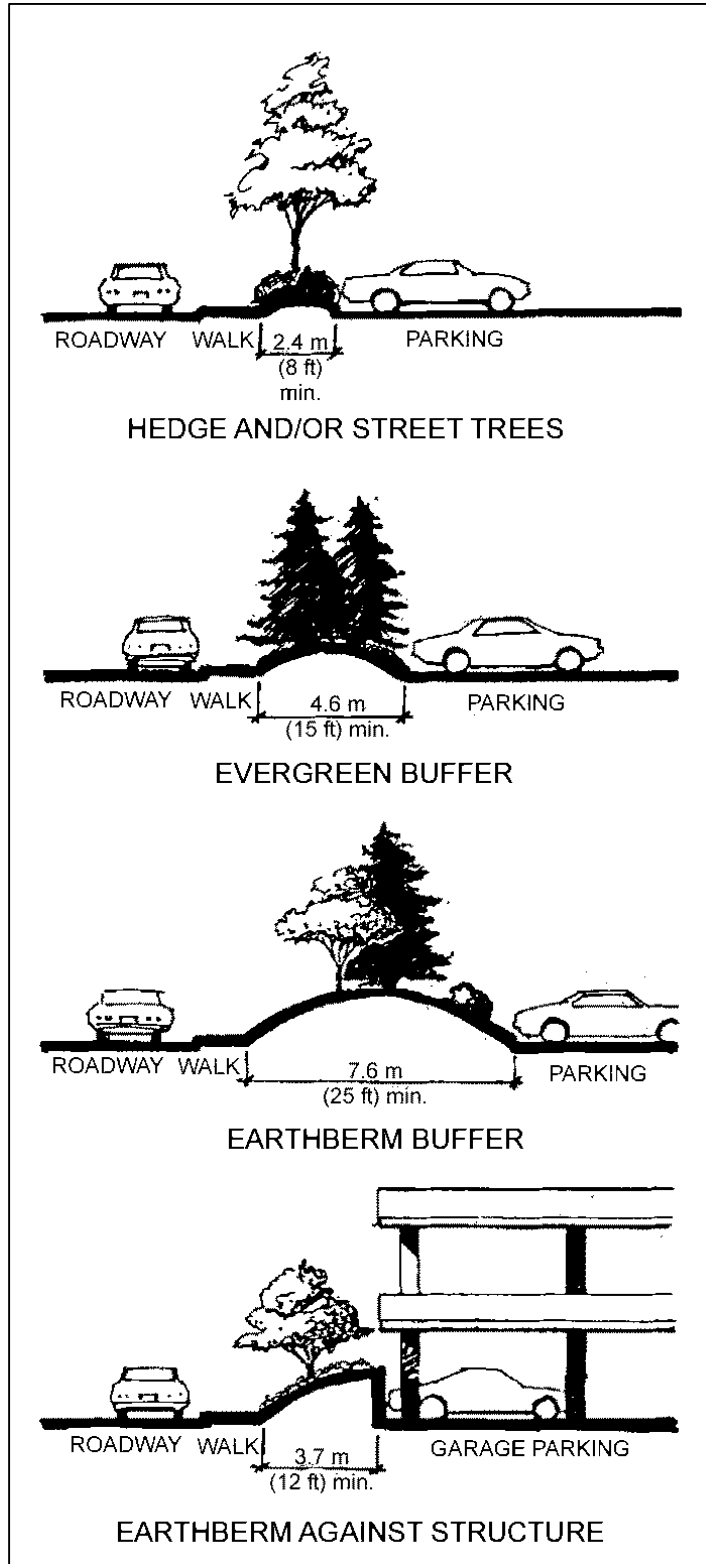

Figure 2-15. Screening parking areas

APPENDIX A
REFERENCES

GOVERNMENT PUBLICATIONS

ER 1110-1-8152	Professional Registration
MIL-HDBK-1022	Petroleum Fuel Facilities
TM 5-803-13	Landscape Design and Planning, August 1988
TM 5-811-1	Electrical Power Supply and Distribution, April 1995
TM 5-822-2	General Provisions and Geometric Design for Roads, Streets, Works, and Open Storage Areas, July 1987
TM 5-822-5	Pavement Design for Roads, Streets, Walks, and Open Storage Areas, June 1992, Change 2, August 1993
DoD Standard	Architectural Barriers Act (ABA) Accessibility Standard for Department of Defense Facilities, 2008

NONGOVERNMENT PUBLICATIONS

AASHTO	A Policy on Geometric Design of Highways and Streets, 1990
ANSI D 6.1e	Manual on Uniform Traffic Control Devices for Streets and Highways