

SEAL SIZE "C"

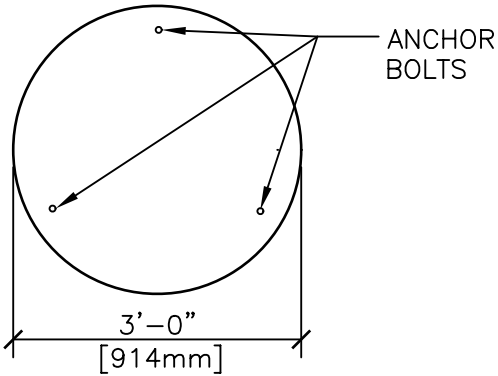

SEAL SIZE "B"



SEAL SIZE "A"

ELEVATIONS

DRILL (3) - 1 1/2" [38mm] ROUND HOLES. MOUNT SEAL ON SOLID MASONRY OR CONCRETE. ANCHOR WITH NON-SHRINK MORTAR.

3/8" [10mm] THREADED BRONZE STUDS, SCREW INTO SOLID METAL PORTION AT BACK OF SEAL.

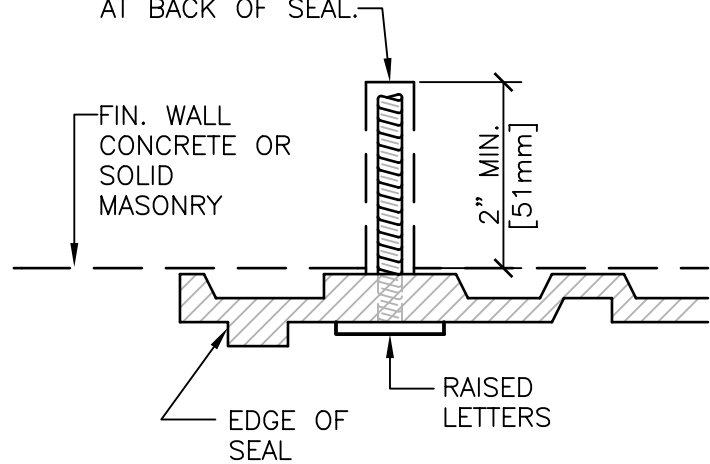

SECTION @ FASTENER

GENERAL NOTES:

1. SEALS LOCATION SHOULD BE TAKEN FROM CONTRACT DRAWINGS.
2. SEALS ARE FURNISHED BY THE DEPARTMENT OF VETERANS AFFAIRS AND INSTALLED BY THE GENERAL CONTRACTOR.
3. SIZE OF THE SEAL SHALL BE DETERMINED BY THE VA.
4. MATERIAL IS CAST BRONZE.
5. DETAIL OF ANCHORAGE MUST BE PROVIDED BY A/E FOR ANCHORAGE IN ANY MATERIAL OTHER THAN SOLID MASONRY OR CONCRETE.

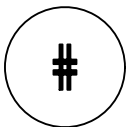

SEALS, EXTERIOR

NTS



Department of Veterans Affairs

DETAIL TITLE / SEALS, EXTERIOR

SCALE :NONE

DATE ISSUED: DECEMBER 2008

CAD DETAIL NO.:

SD101400-01.DWG

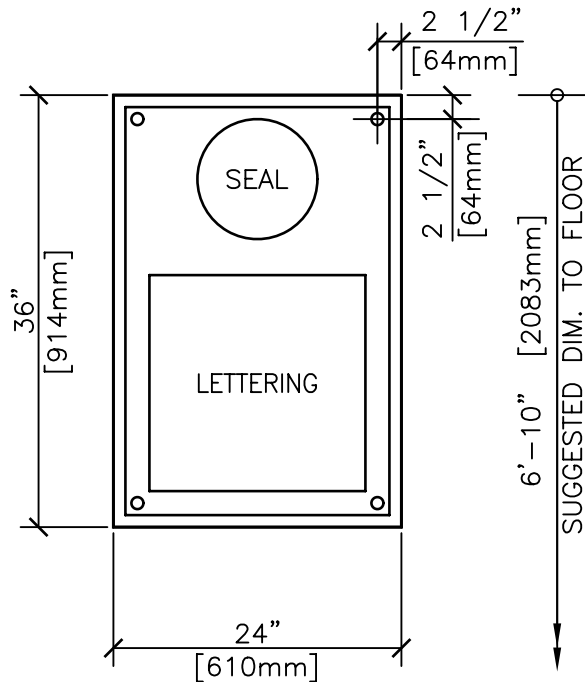

ELEVATION OF PLAQUE

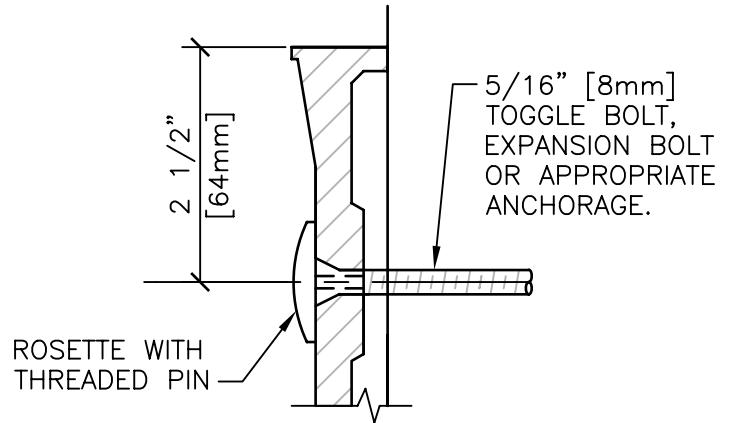

DETAIL OF FASTENING

GENERAL NOTES:

1. LOCATE PLAQUE IN LOBBY OR A LOCATION SELECTED BY THE PROJECT DIRECTOR.
2. PLAQUE WILL BE FURNISHED BY THE VA & INSTALLED BY THE GENERAL CONTRACTOR.

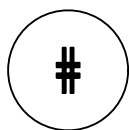

DEDICATION PLAQUE

NTS



Department of
Veterans Affairs

DETAIL TITLE / DEDICATION PLAQUE

SCALE :NONE

DATE ISSUED: DECEMBER 2008

CAD DETAIL NO.: SD101400-02.DWG

HOLES CUT IN CONCRETE OR SOLID MASONRY AND FILLED WITH MORTAR IMMEDIATELY BEFORE SETTING SEAL.

3/8" [10mm] THREADED STUDS SCREWED INTO SOLID METAL PORTION ON BACK OF SEAL. SEAL THEN TO BE POSITIONED INTO HOLES WHILE MORTAR IS STILL DAMP. PROVIDE BRONZE BOLTS FOR BRONZE SEAL.

2" MIN.
[51mm]

PROVIDE SPECIAL DETAIL FOR ANCHORAGE WHERE SEAL IS ATTACHED TO OTHER MATERIAL.

EXTERIOR FACE OF CONCRETE OR SOLID MASONRY WALL.

SAME AS ABOVE

SOLID METAL PORTION ON BACK OF SEAL. DRILL AND TAP FOR STUDS - 3 LOCATIONS AS INDICATED ON ELEVATIONS.

FRONT FACE OF SEAL
MEDIUM PEBBLE FINISH - ALL BACKGROUND AREAS

PROFILE OF SEAL

LOCATION OF SOLID METAL PORTION ON BACK OF SEAL.

LOCATION OF SOLID METAL PORTION ON BACK OF SEAL.

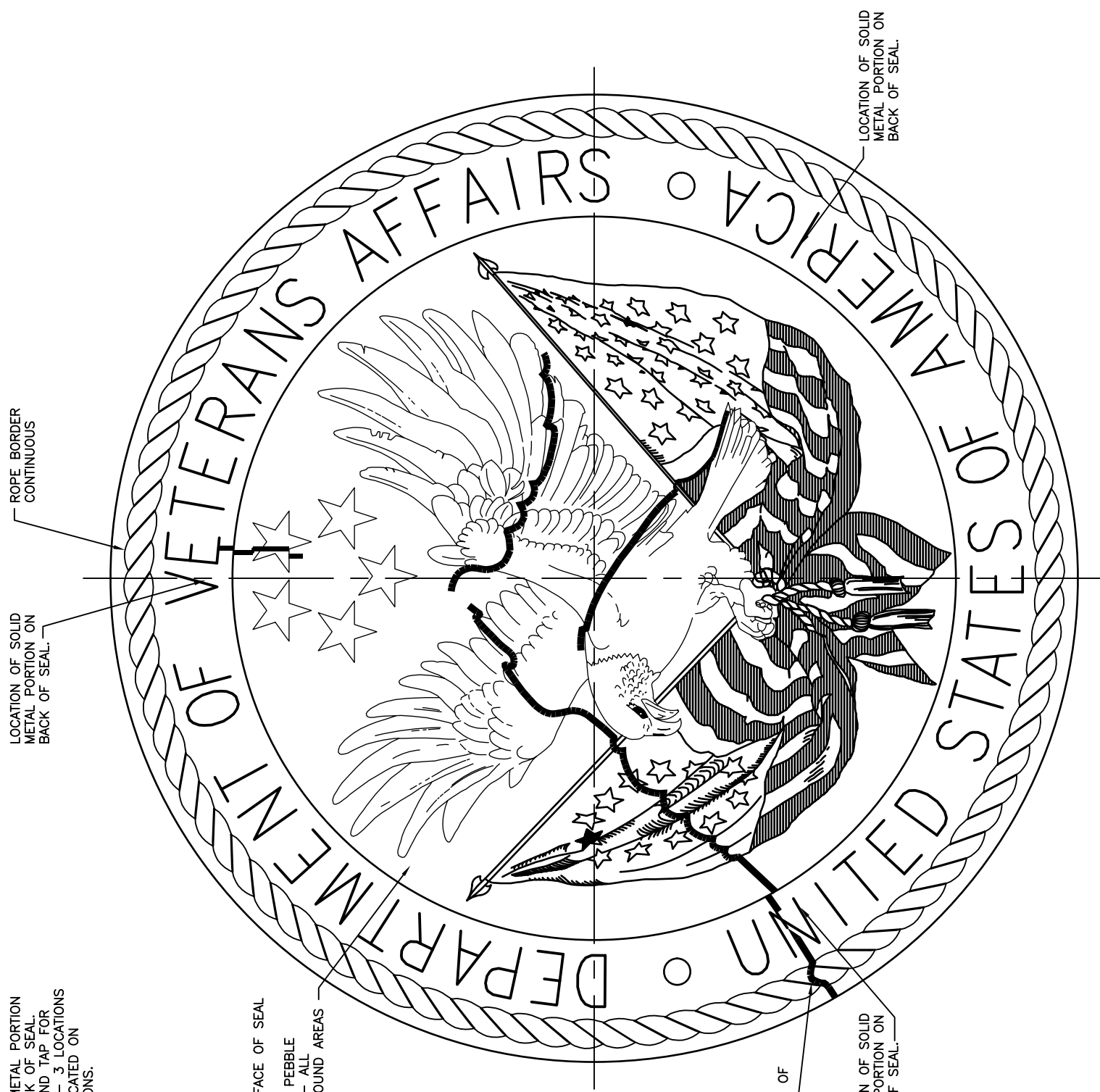

SECTION THROUGH SEAL SHOWING METHOD OF ATTACHMENT

ELEVATION OF 30" [762mm], 36" [914mm], AND 48" [1219mm] DIAMETER SEALS

NOTES:

1. MATERIAL:
BRONZE: FEDERAL SPECIFICATION QQ-C-535B, COMPOSITION 2.
2. WORKMANSHIP:
CASTINGS SHALL BE OF UNIFORM QUALITY AND CONDITION, FREE FROM INJURIOUS BLOWHOLES AND POROSITY, CRACKS AND OTHER DEFECTS AND NOT WARPED OR DISTORTED, WELL FINISHED, FREE FROM BURRS, SHARP EDGES, SCRATCHES AND DEFECTS THAT MAY AFFECT APPEARANCE OR SERVICEABILITY. CASTINGS SHALL NOT BE REPAIRED, PLUGGED, WELDED, OR BURNED.
3. FINISH:
FINISH TO BE DETAILED, HAND CHASED FOR TRUE ALIGNMENT, FILED, BELT POLISHED SIDES, GROUND SMOOTH, RAISED SURFACES AND BORDERS, SUCH AS ALL RAISED PORTIONS OF SEAL, EAGLE, SHIELD, LETTERING, ROPE BORDER ETC., TO BE POLISHED AND BUFFED TO A BRIGHT SATIN FINISH, BACKGROUND TEXTURES TO BE REVERSE MEDIUM PEBBLE BACKGROUND, FINE PEBBLE BACKGROUND, MOSS AS CAST, AS INDICATED.
4. COATING:
BRONZE: CHEMICALLY OXIDIZE TO A STATUARY MEDIUM COLOR AND FINISH WITH ONE COAT OF CLEAR PROTECTIVE EXTERIOR METAL LACQUER.
5. FASTENERS:
CORROSION RESISTING METAL COMPATIBLE WITH MATERIAL OF CASTING.

EXTERIOR SEALS DETAIL

NTS



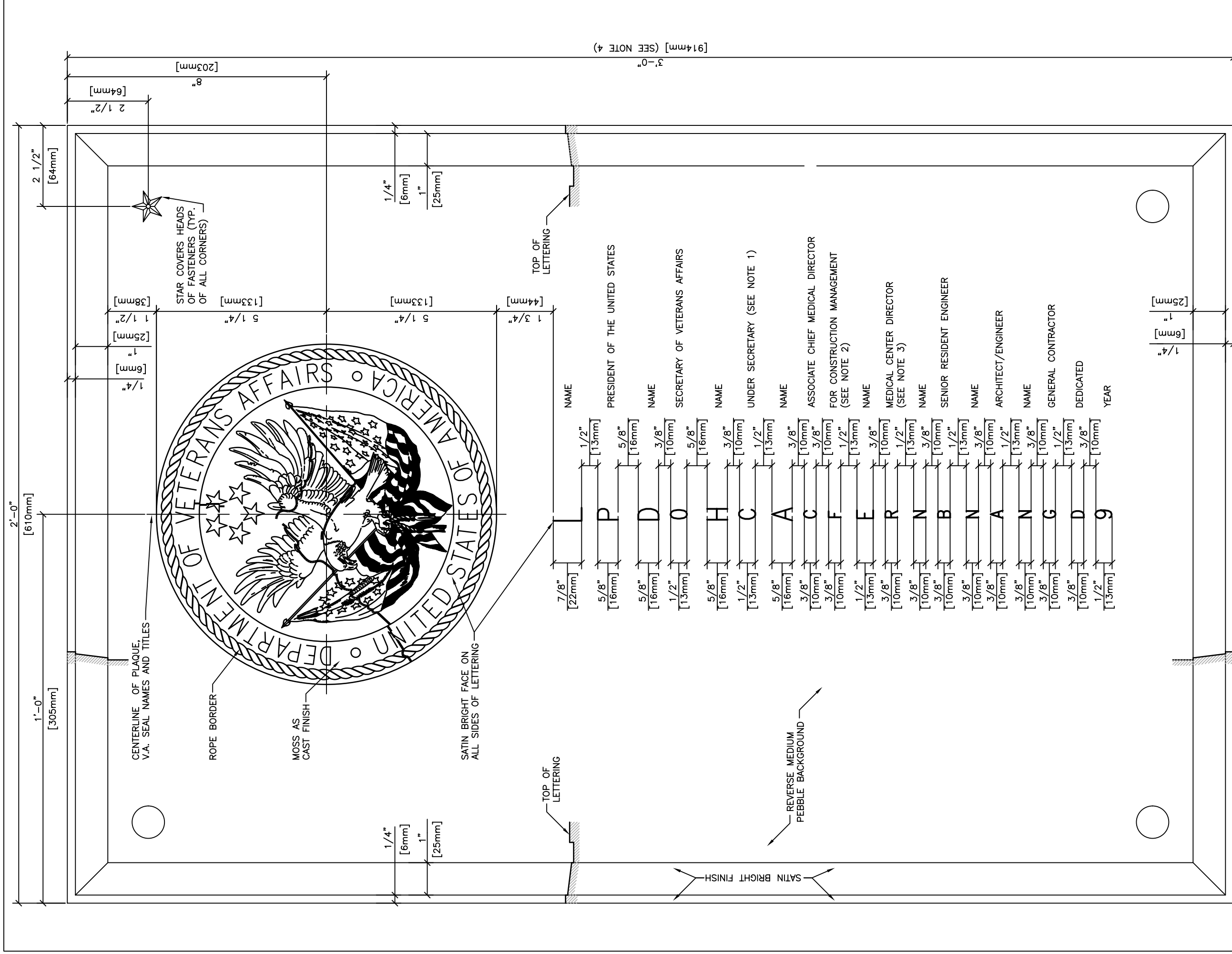

NTS DEDICATION PLAQUE STANDARD DETAIL

Department of Veterans Affairs

DETAIL TITLE / DEDICATION PLAQUE STANDARD DETAIL

SCALE : NONE

DATE ISSUED: DECEMBER 2008

CAD DETAIL NO.: SD101400-04.DWG

DEDICATION PLAQUE NOTES:

1. UNDER SECRETARY FOR HEALTH, OR UNDER SECRETARY FOR BENEFITS, OR BOTH MAY BE REQUIRED.
2. SOME PLAQUES WILL NOT INCLUDE ASSOCIATE CHIEF MEDICAL DIRECTOR FOR OFM CONSTRUCTION MANAGEMENT. ADJUST SPACING BETWEEN LINES OF TEXT AND INCREASE DIMENSION BELOW LAST LINE TO ACCOMMODATE THE NUMBER OF LINES OF TEXT.
3. MEDICAL CENTER DIRECTOR, REGIONAL VISN OFFICE DIRECTOR, REGIONAL OFFICE AND INSURANCE CENTER DIRECTOR, OR MEDICAL AND REGIONAL OFFICE CENTER DIRECTOR MAY BE REQUIRED. LONG TEXT LINES MAY REQUIRE TWO LINES AND ADJUSTMENT OF SPACING.
4. DEDICATION PLAQUES FOR SATELLITE OUTPATIENT CLINICS WILL OMIT THE SENIOR RESIDENT ENGINEER, ARCHITECT/ENGINEER, AND GENERAL CONTRACTOR. THE OVERALL HEIGHT OF THE PLAQUE SHALL BE 30 INCHES [762mm].
5. MATERIAL: THE PLAQUE SHALL BE CAST OF A LEAD FREE TIN BRONZE, SUCH AS C90300 (NAVY "G" BRONZE) OR SIMILAR ALLOY APPROVED BY V.A.
6. WORKMANSHIP: CASTINGS SHALL BE OF UNIFORM QUALITY AND CONDITION, FREE FROM INJURIOUS BLOW HOLES AND POROSITY, CRACKS, AND OTHER DEFECTS AND NOT WARPED OR DISTORTED, WELL FINISHED, FREE FROM BURRS, SHARP EDGES, SCRATCHES, AND DEFECTS THAT MAY AFFECT APPEARANCE OR SERVICE-ABILITY. CASTINGS SHALL NOT BE REPAIRED, PLUGGED, WELDED, OR BURNED.
7. FINISH: FINISH TO BE DETAILED, HAND CHASED FOR TRUE ALIGNMENT FILED, BELT POLISHED SIDES GROUND SMOOTH, RAISED SURFACES AND BORDERS TO BE POLISHED AND BUFFED TO A BRIGHT SATIN FINISH, BACKGROUND TEXTURES TO BE REVERSE MEDIUM PEBBLE BACKGROUND, FINE PEBBLE BACKGROUND, MOSS AS CAST, AS INDICATED.
8. COATING: BRONZE TO BE CHEMICALLY OXIDIZED TO A STATUARY MEDIUM COLOR AND FINISH WITH ONE COAT OF CLEAR PROTECTIVE EXTERIOR METAL LACQUER.
9. FASTENERS: CORROSION RESISTANT METAL COMPARABLE WITH MATERIAL OR CASTING.
10. TEXT: INFORMATION FOR FILLING OUT PLAQUE WILL BE PROVIDED BY THE DEPARTMENT OF VETERANS AFFAIRS AT TIME OF ORDER FOR INDIVIDUAL PLAQUE. PRIOR TO CASTING, RUBBINGS WILL BE PROVIDED TO VA FOR REVIEW.
11. THE USE OF METRIC DIMENSIONING IS ALLOWED, PROVIDED THAT THE METRIC EQUIVALENT IS COMPARABLE AND MEETS FEDERAL STANDARDS FOR CONVERSION.



Department of
Veterans Affairs

DETAIL TITLE / DEDICATION PLAQUE DETAIL NOTES

SCALE :NONE

DATE ISSUED: DECEMBER 2008

CAD DETAIL NO.: SD101400-05.DWG

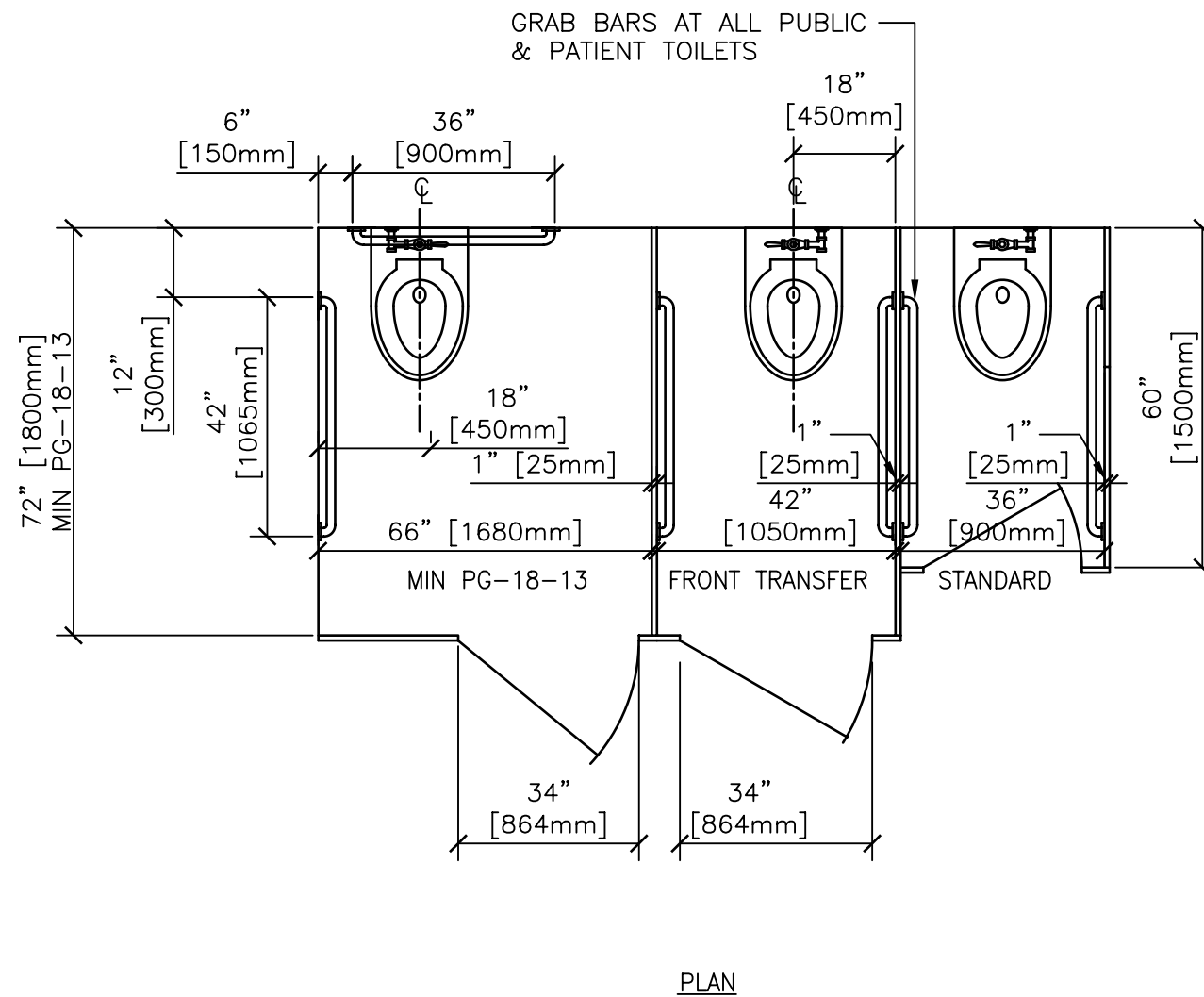
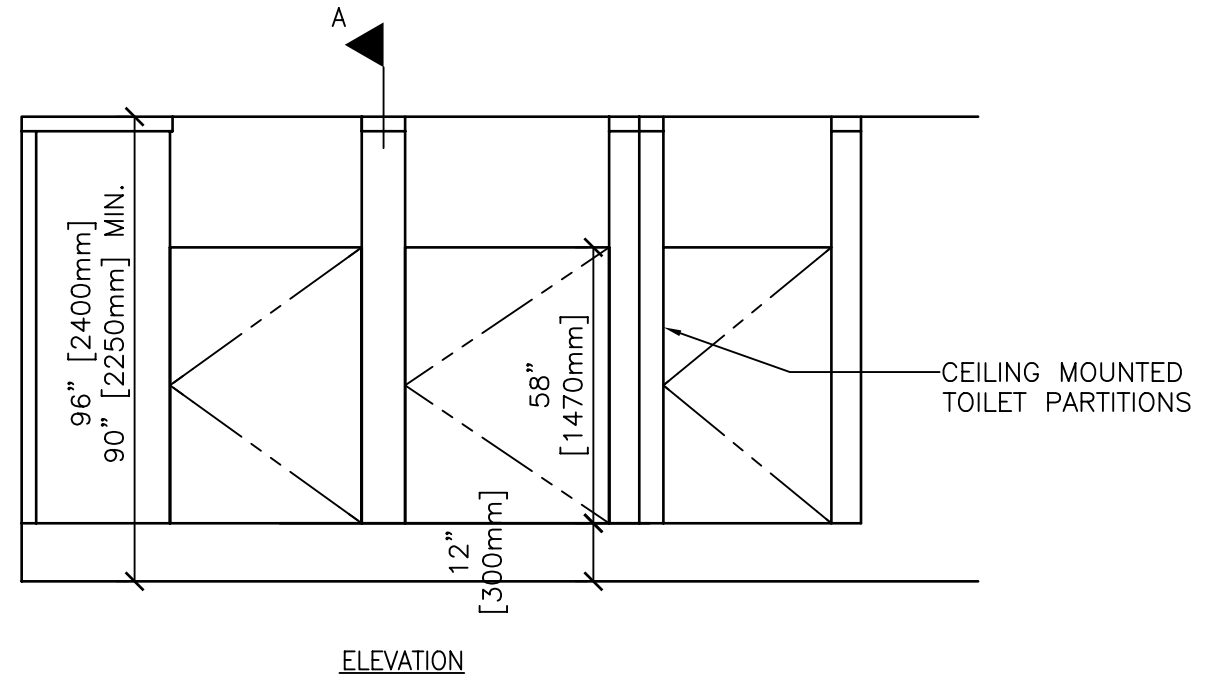
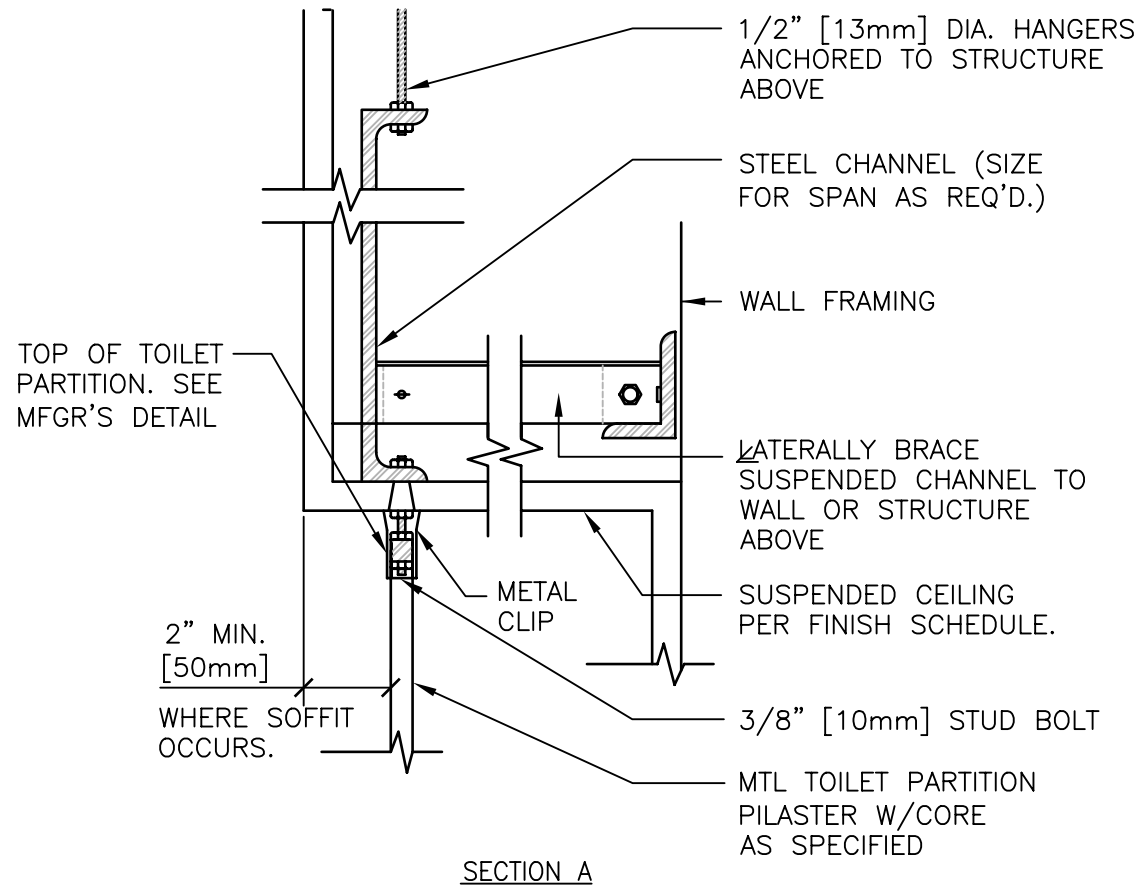

NOTES:

A/E SHALL LOCATE GRAB BARS AND TOILET ACCESSORIES IN ACCORDANCE WITH CHAPTER 6 OF THE ADA-ABA ACCESSIBILITY STANDARD.

VA BARRIER FREE DESIGN GUIDE PG-18-13 SPECIFIES LARGER WHEELCHAIR ACCESSIBLE STALLS AND FRONT TRANSFER (AMBULATORY ACCESSIBLE) STALLS THAN REQUIRED BY ADA-ABAAS. GRAB BARS ARE REQUIRED IN ALL TOILET STALLS, NOT JUST ACCESSIBLE STALLS.

DETAIL TITLE / TOILET STALL DETAILS

Department of
Veterans Affairs



SCALE : NONE

DATE ISSUED: DECEMBER 2008

CAD DETAIL NO.: SD102113-01.DWG

PLAN A

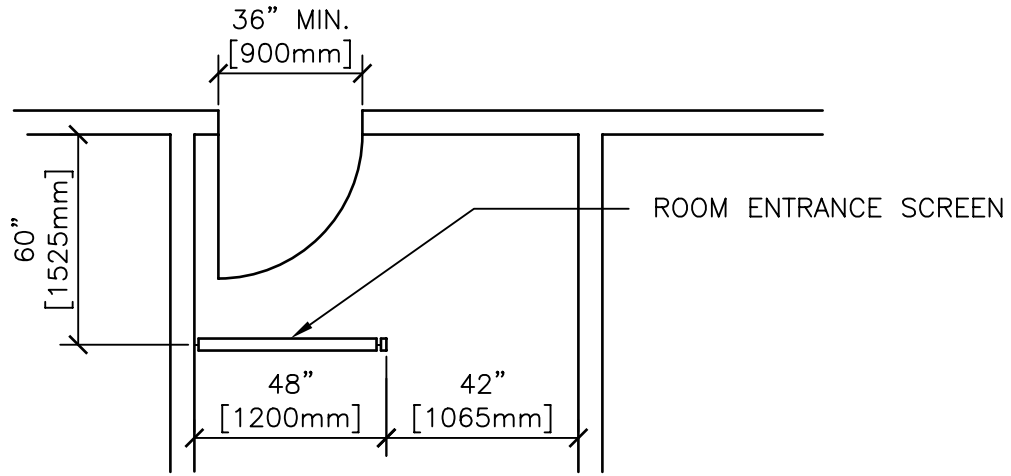

PLAN B

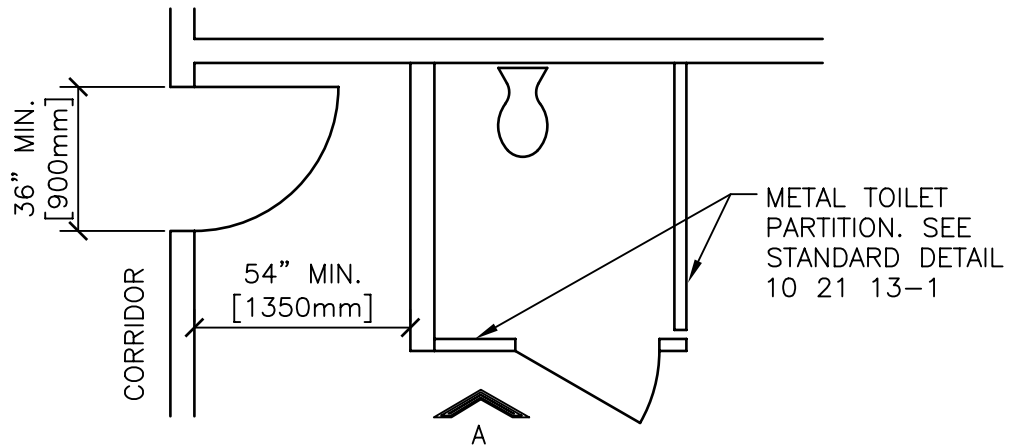

ELEVATION A

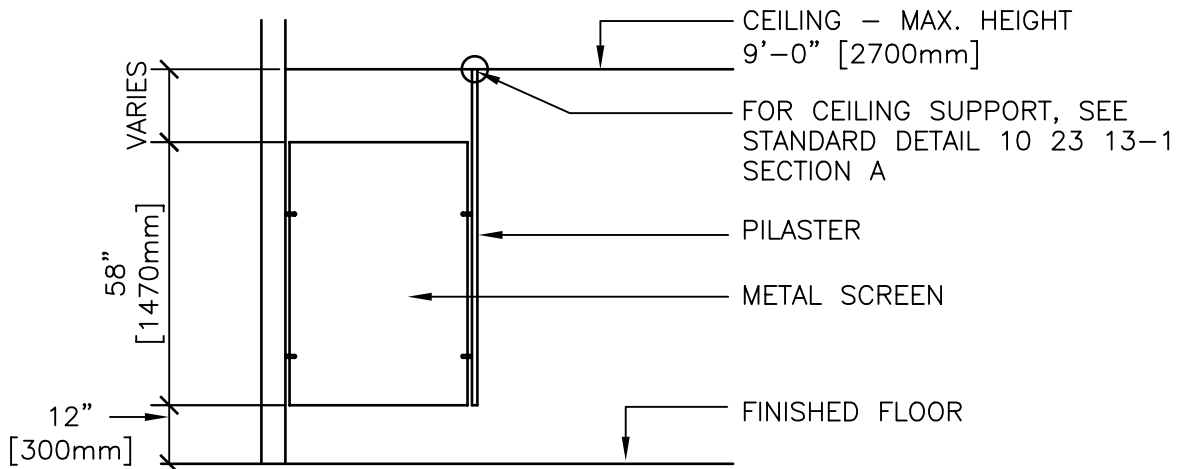

ENTRANCE SCREENS FOR WHEELCHAIR TOILETS

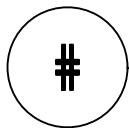

NTS



Department of
Veterans Affairs

DETAIL TITLE / ENTRANCE SCREENS FOR
WHEELCHAIR TOILETS

SCALE :NONE

DATE ISSUED: DECEMBER 2008

CAD DETAIL NO.: SD102113-02.DWG

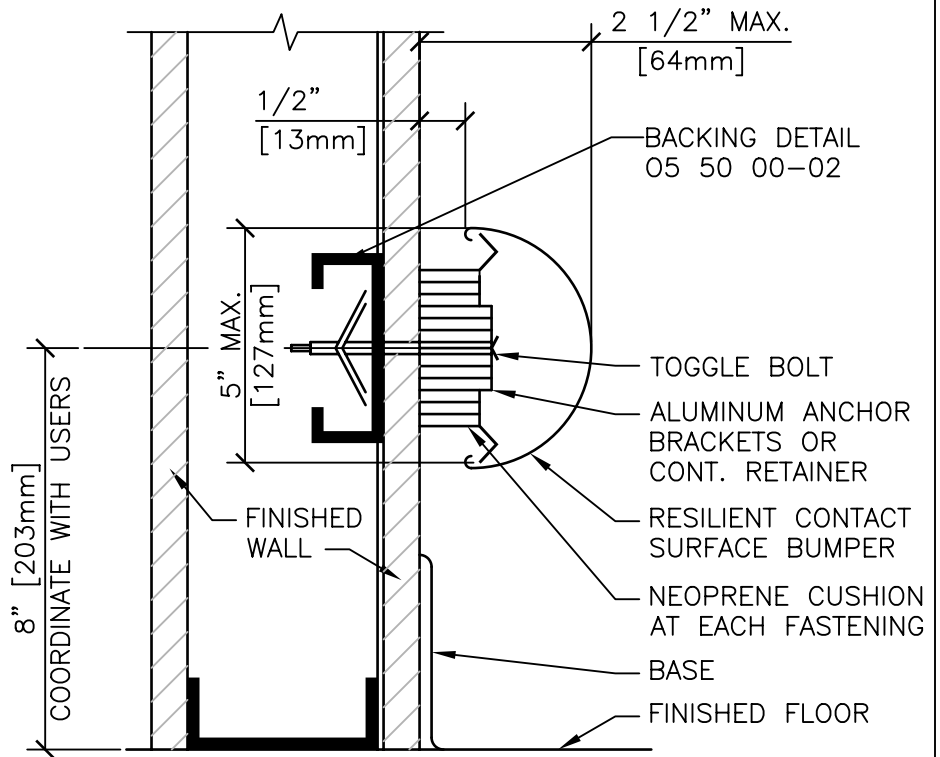

SECTION

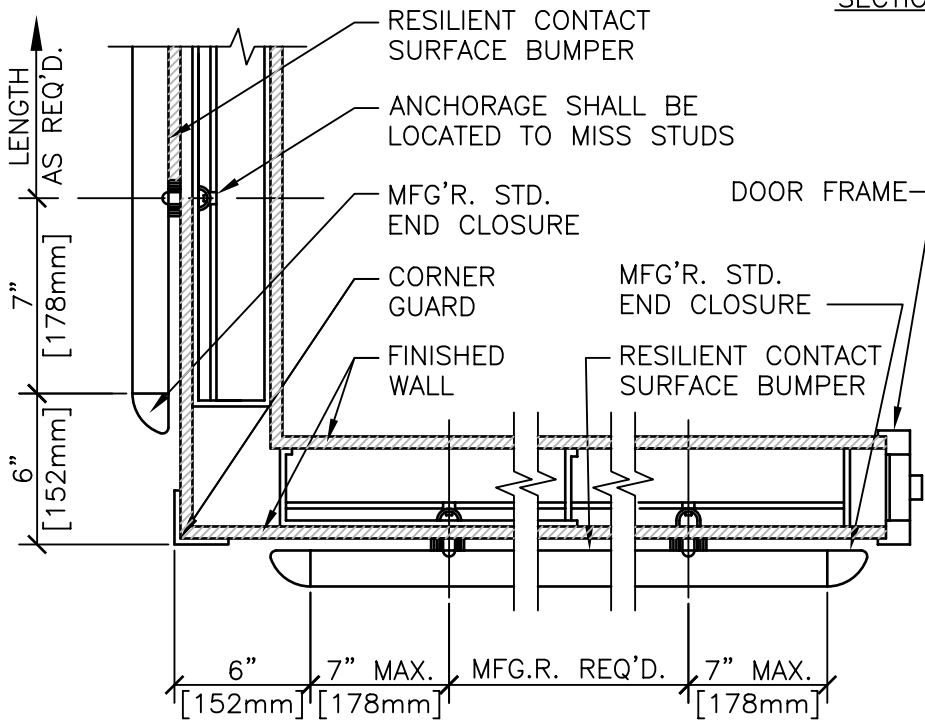

PLAN

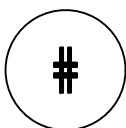

WALL GUARDS

NTS



Department of
Veterans Affairs

DETAIL TITLE / WALL GUARDS

SCALE :NONE

DATE ISSUED: DECEMBER 2008

CAD DETAIL NO.: SD102600-01.DWG

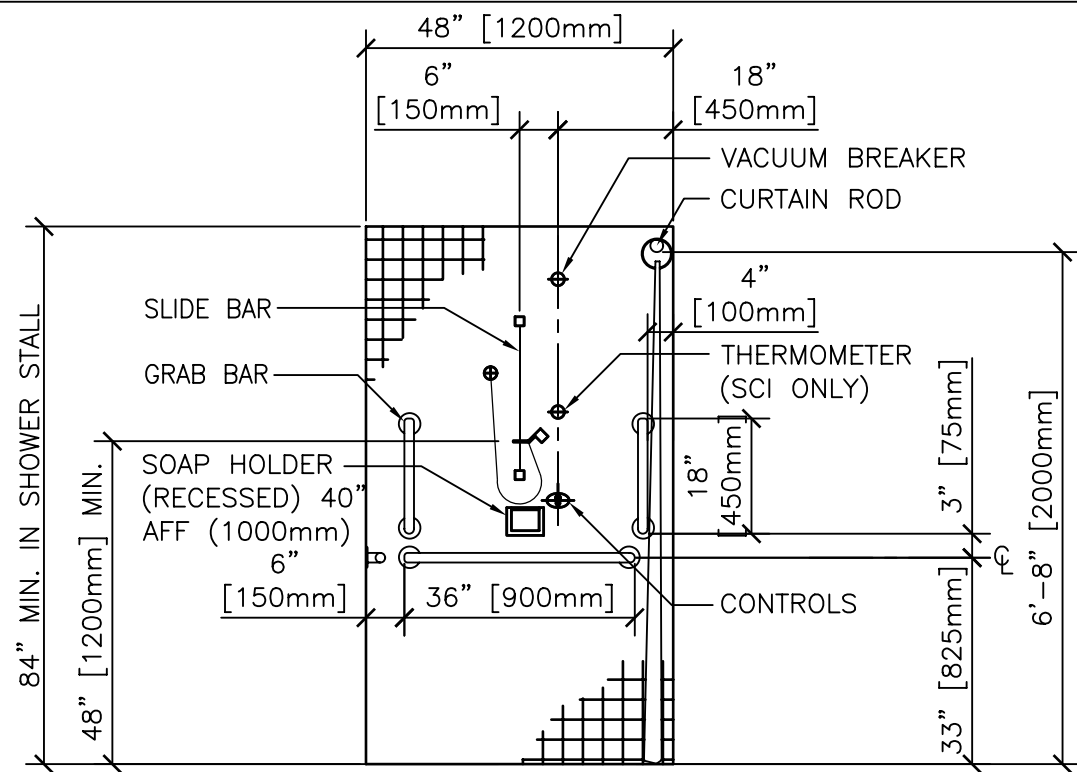

(C) SIDE ELEVATION (CONTROL WALL)

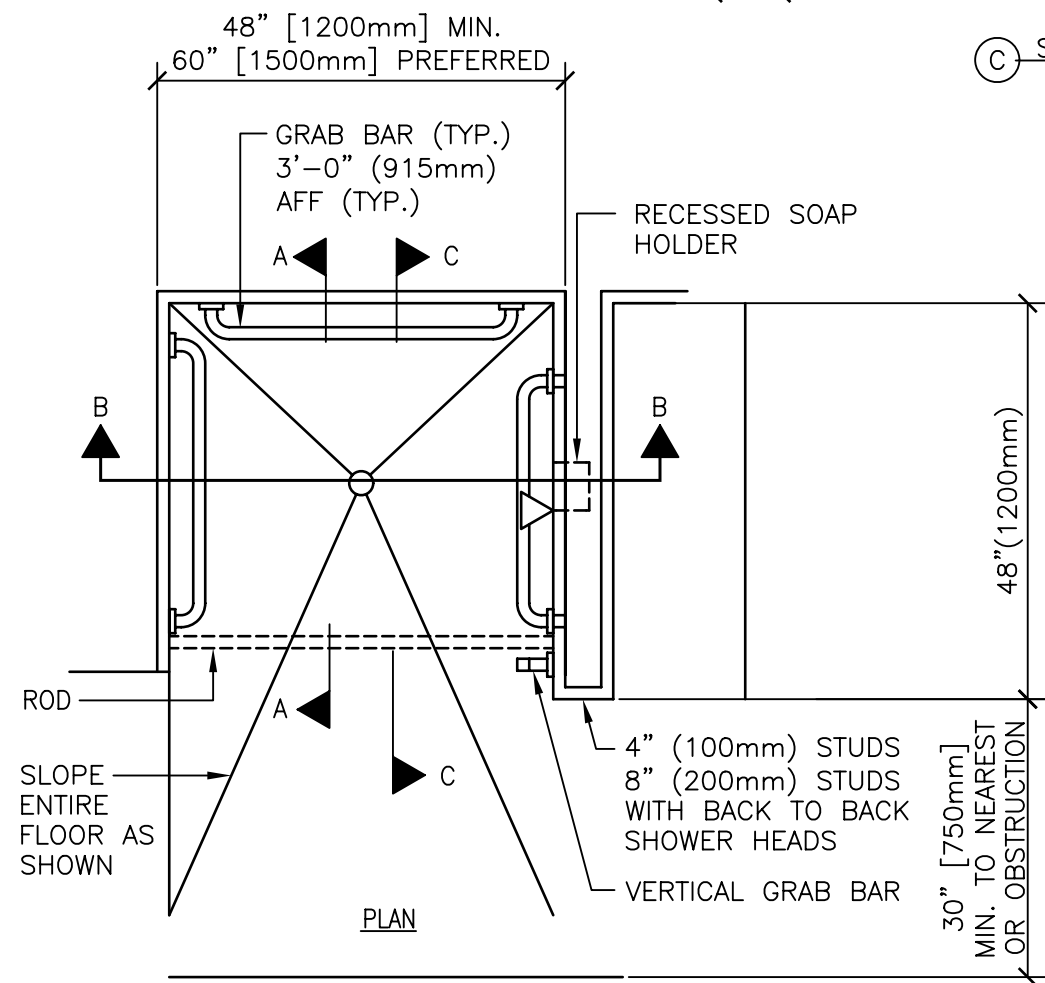

PLAN

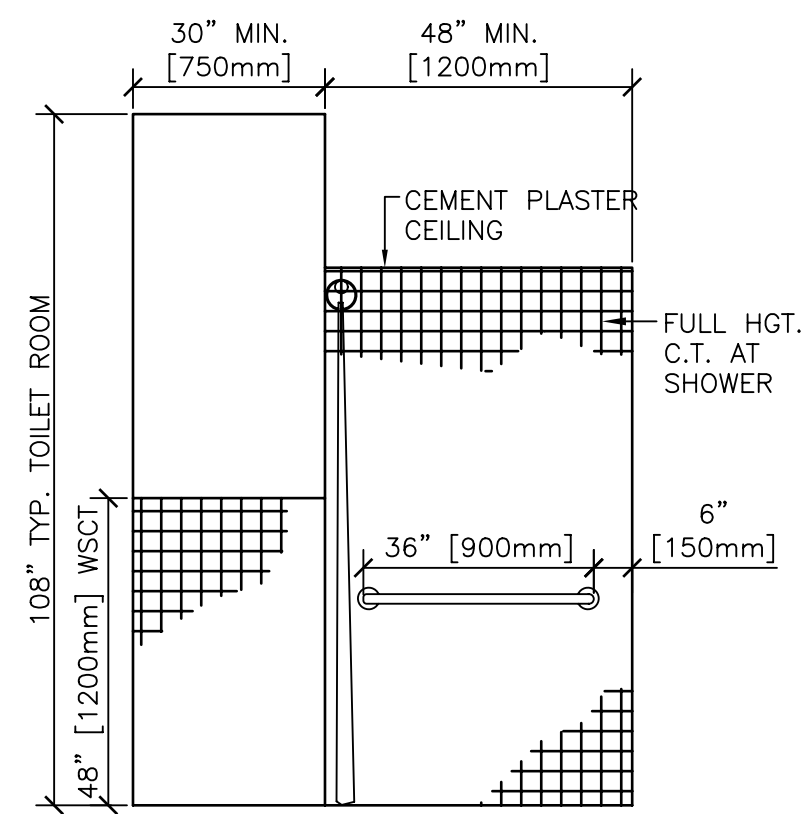

(A) SIDE ELEVATION

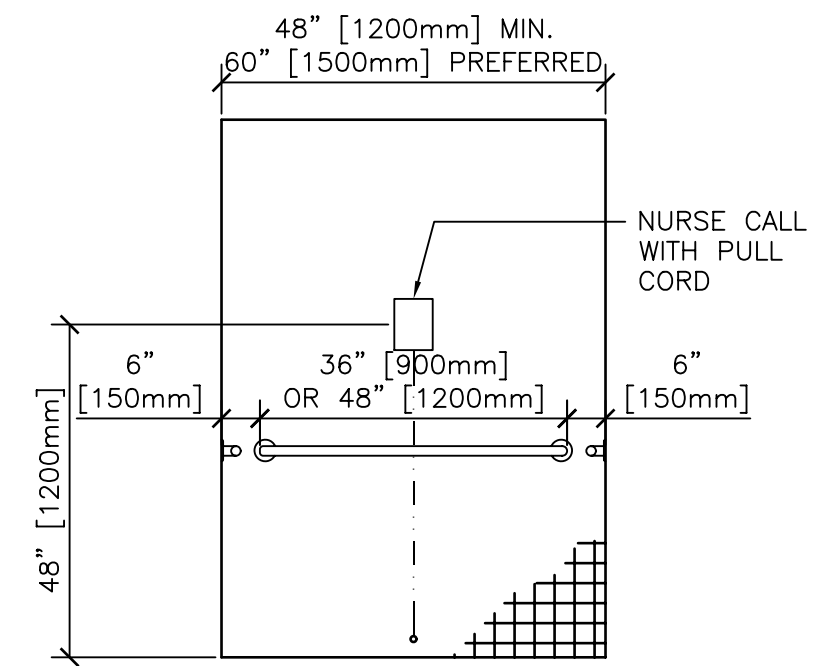

(B) REAR ELEVATION

NOTES:

VA BARRIER FREE DESIGN GUIDE PG-18-13 SPECIFIES MINIMUM 48"x48" [1200x1200mm] ROLL-IN TYPE SHOWER FOR PATIENT BATHING. 90% OF INDIVIDUAL SHOWERS IN MEDICAL-SURGICAL NURSING UNITS (MSN) AND NURSING HOME CARE UNITS (NHCU) SHOULD BE THIS SIZE TO FACILITATE USE OF WHEELCHAIRS, SHOWER SEATS, AND ASSISTED BATHING.

TRANSFER TYPE 36"x36" [900x900mm] AND 30"x60" [750x1500mm] ROLL-IN LITTER SHOWERS MAY BE USED FOR MENTAL HEALTH (MH&B) UNITS, DOMICILIARY, AND STAFF FACILITIES. REFER TO CHAPTER 6 OF THE ADA-ABA ACCESSIBILITY GUIDELINES FOR CRITICAL DIMENSIONS AND GRAB BAR AND ACCESSORY LOCATIONS.

A/E SHALL CAREFULLY COORDINATE FLOOR SLOPES AND DRAIN LOCATIONS TO CONTAIN AND CONTROL WATER FROM THE SHOWER. IN NEW CONSTRUCTION USE 3" [75mm] SLAB DEPRESSION AT SHOWER AND ADJOINING TOILET OR DRYING AREA.

PATIENT ACCESSIBLE SHOWER ROLL-IN
NTS

DETAIL TITLE / PATIENT ACCESSIBLE SHOWER ROLL-IN

SCALE :

DATE ISSUED: DECEMBER 2008

CAD DETAIL NO.: SD102800-01.DWG

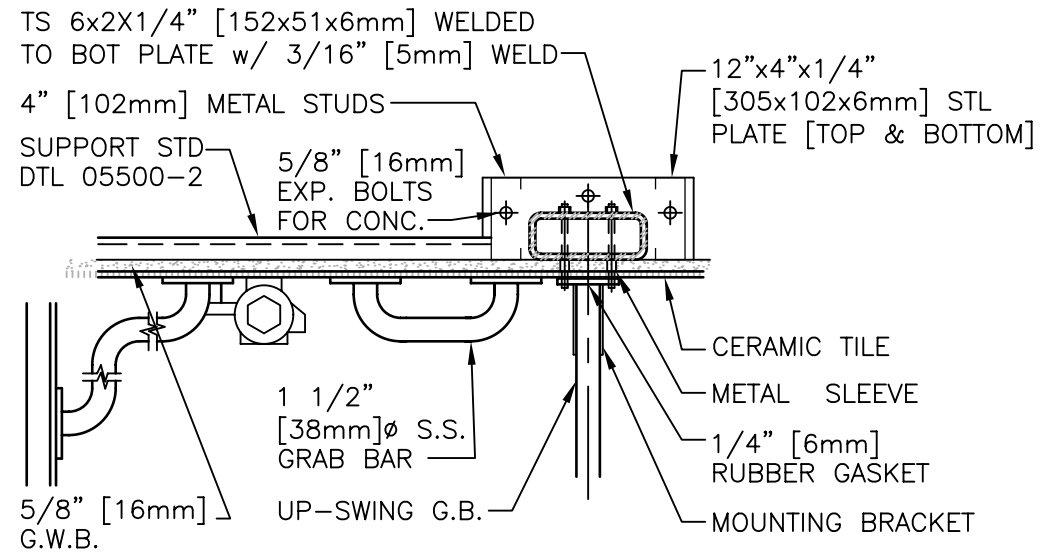

PLAN SHOWING THE STEEL TUBE & PLATE FOR ANCHORING THE UP-SWING GRAB BAR

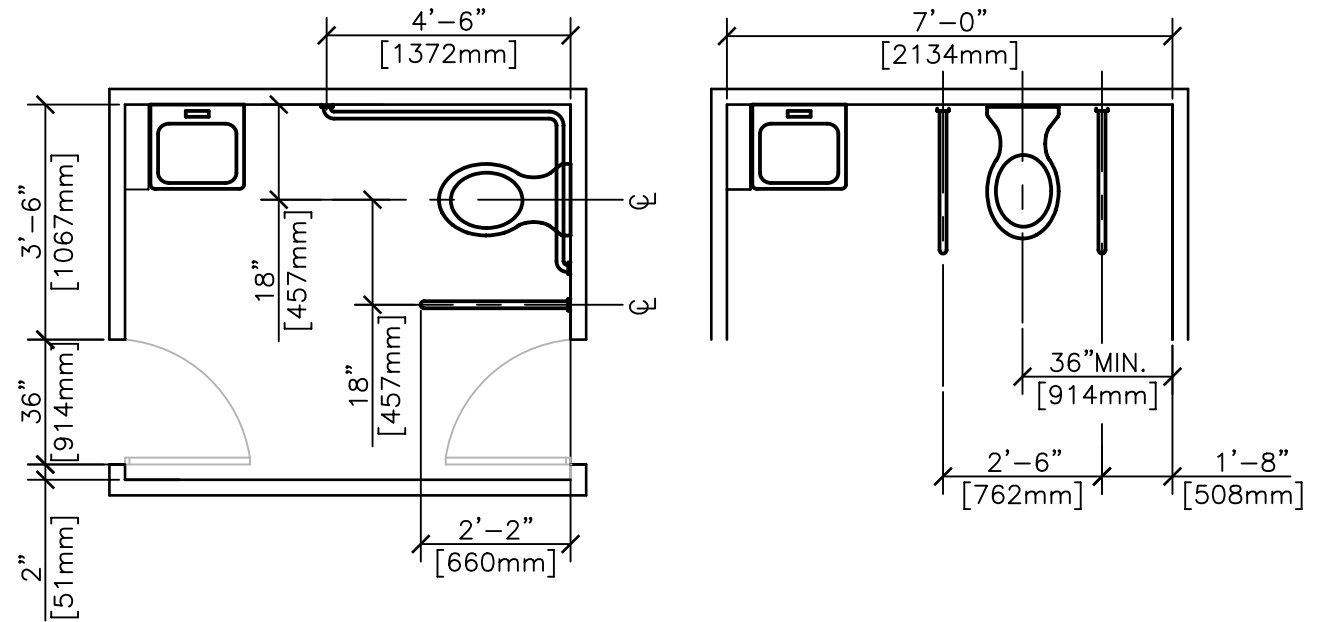

PLAN OF TOILET ROOM SHOWING RELATIONSHIP OF FIXTURES

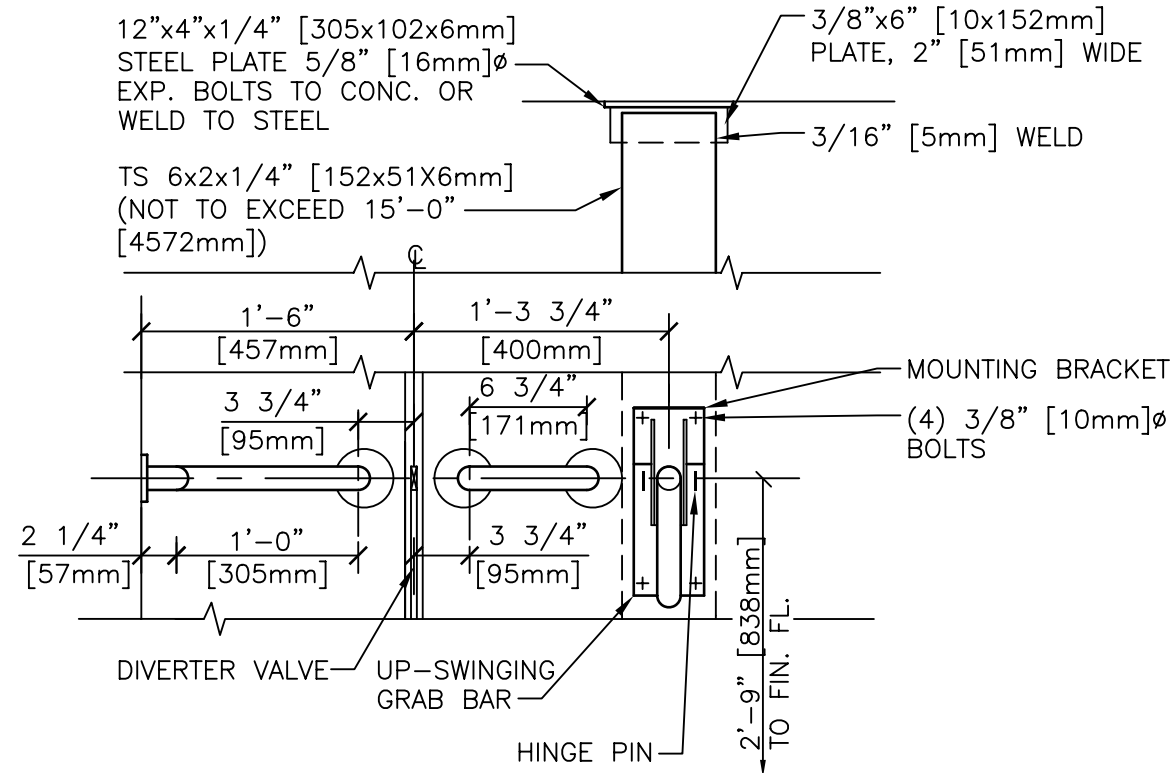

ELEVATION SHOWING POSITION OF UP-SWINGING GRAB BAR

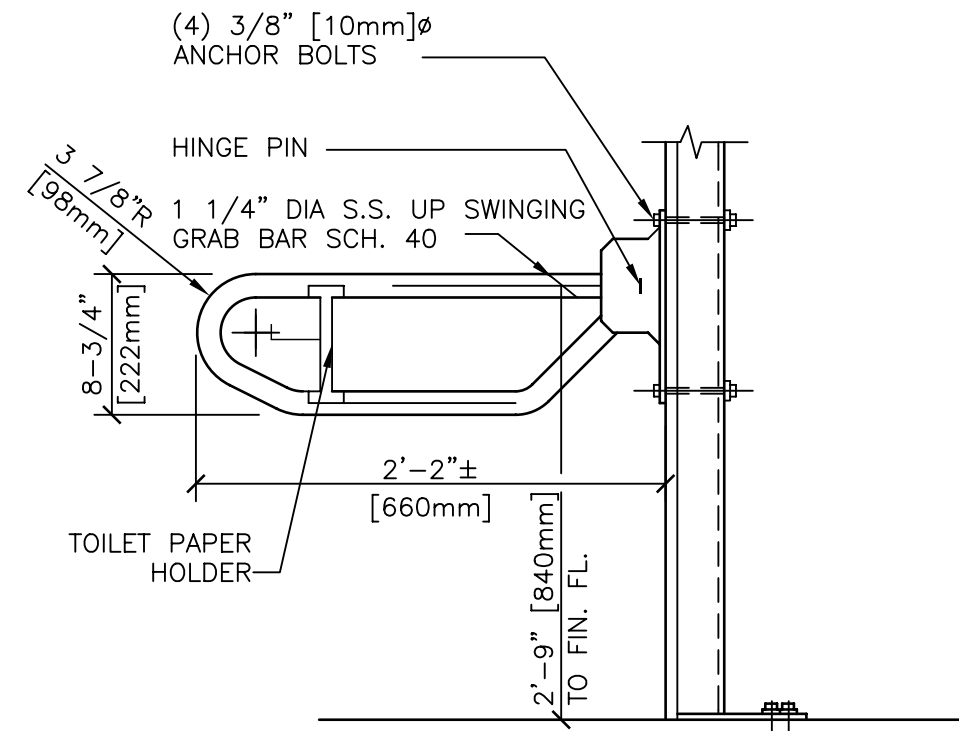

SIDE ELEVATION OF UP-SWINGING GRAB BAR

GENERAL NOTES:

1. INSTALLATION AS SHOWN IS FOR WATER CLOSET WITH DIVERTER VALVE.

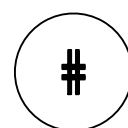

UP-SWING GRAB BAR

NTS

DETAIL TITLE / UP-SWING GRAB BAR

SCALE : NONE

DATE ISSUED: DECEMBER 2008

CAD DETAIL NO.: SD102800-02.DWG



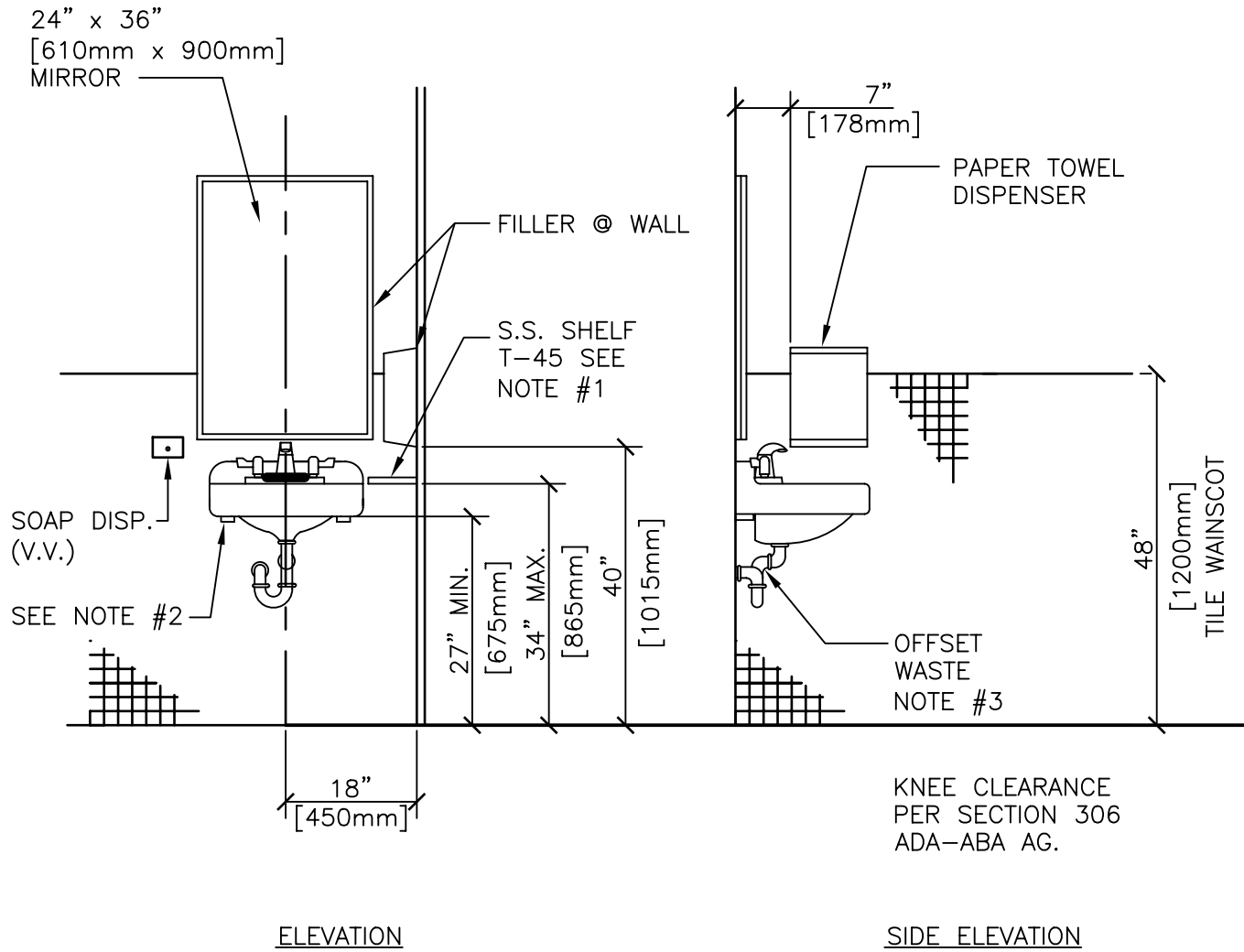

1. SHELF IF IN EQUIPMENT LIST 7610; SEE DETAIL 10 28 00-4
2. LAVATORY, WITH WRIST OR SENSOR CONTROL FAUCET
3. INSULATE HOT SUPPLY AND WASTE.



Department of
Veterans Affairs

DETAIL TITLE / ACCESSIBLE LAVATORY

SCALE : NONE

DATE ISSUED :DECEMBER 2008

CADD DETAIL NO. : SD102800-03.DWG

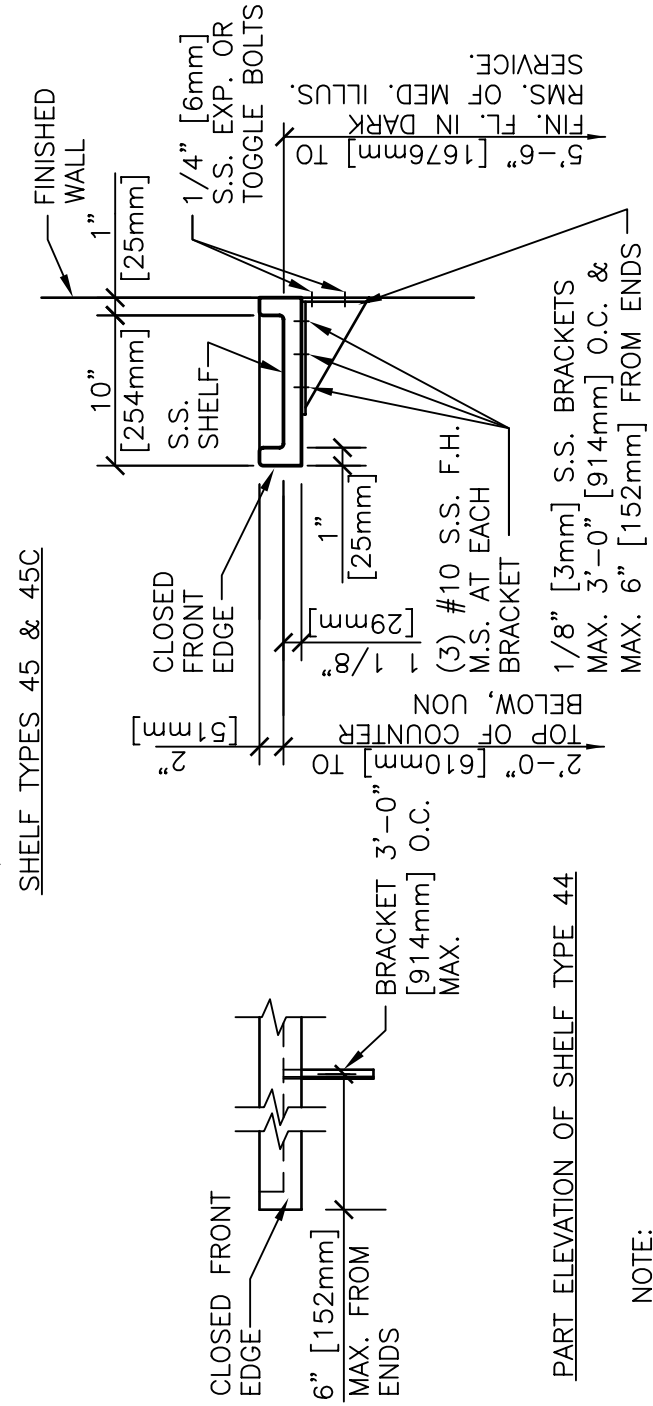
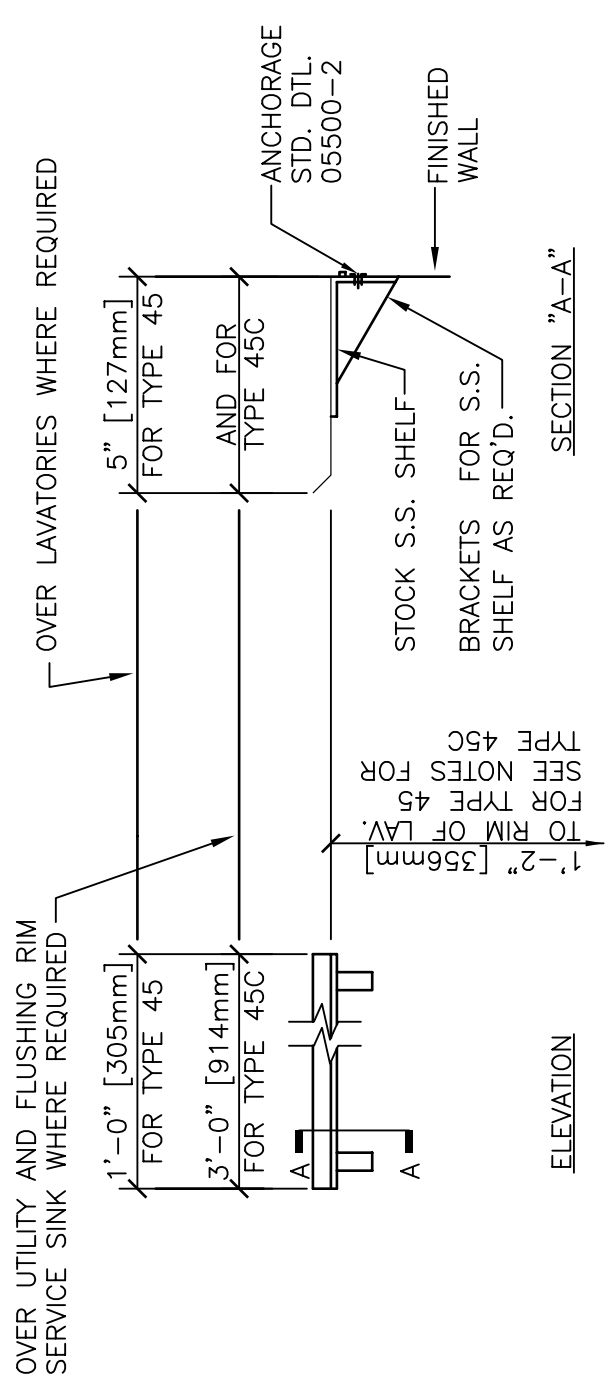

NOTE:
SEE ARCHITECTURAL PLANS FOR LENGTH OF SHELF.

SHELF TYPE 44

GENERAL NOTES:

1. SEE ARCH. PLANS FOR LOCATION OF STAINLESS STEEL SHELVES TYPES 44, 45 & 45C.
2. TOP OF SHELF TYPE 45C SHALL BE LOCATED 1'-5" [432mm] ABOVE RIM OF UTILITY SINK.
3. WHERE SHELF TYPE 45C OCCURS ABOVE FLUSHING RIM SERVICE SINK IT SHALL CLEAR FITTING SUPPORT A MINIMUM OF 2" [51mm].
4. SEE ARCH. PLANS FOR EXTENT OF SHELVING AND ACTUAL SPACING OF BRACKETS.

NTS

SHELVES TYPE 44, 45 AND 45C

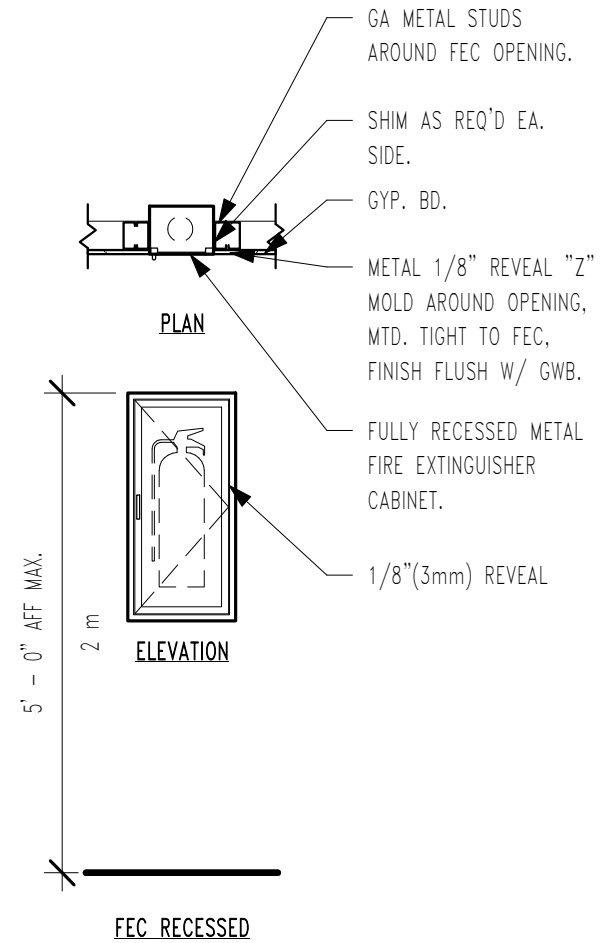
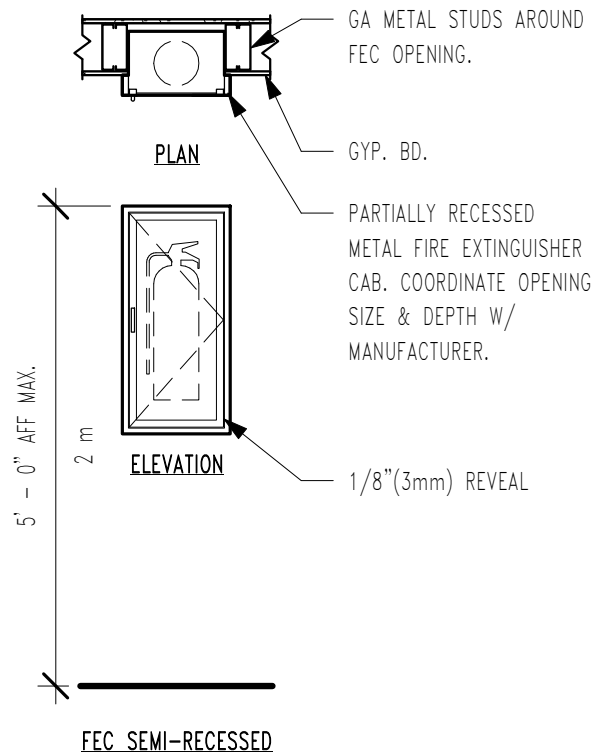
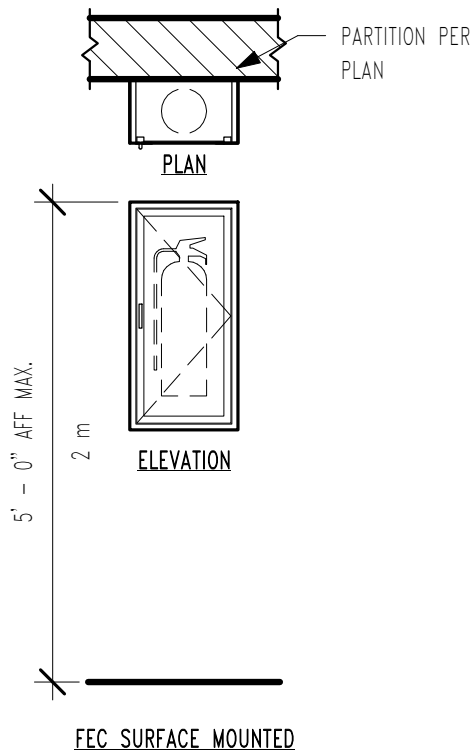

FIRE EXTINGUISHER CABINET (FEC)

Scale: 1/2" = 1'-0"

NOTE:

1. APPROXIMATE INTERIOR DIMENSION: 8"x12"x27" 203mmX305mmX686mm.
2. CABINET TO CONTAIN MIN. 2-1/2 GAL. FIRE EXTINGUISHER.
3. AVOID INSTALLING EXTINGUISHER CABINETS IN FIRE BARRIER WALLS.
4. PROVIDE FULL CLEAR ACRYLIC DOOR.

DETAIL TITLE: FIRE EXTINGUISHER CABINET (FEC)



SCALE: 1/2" = 1'-0"

DATE ISSUED: 03/01/23

CAD DETAIL NO.: SD104413-01