

UNIFIED FACILITIES CRITERIA (UFC)

WAREHOUSES AND STORAGE FACILITIES



UNIFIED FACILITIES CRITERIA (UFC)

WAREHOUSES AND STORAGE FACILITIES

Any copyrighted material included in this UFC is identified at its point of use. Use of the copyrighted material apart from this UFC must have the permission of the copyright holder.

U.S. ARMY CORPS OF ENGINEERS

NAVAL FACILITIES ENGINEERING COMMAND (Preparing Activity)

AIR FORCE CIVIL ENGINEER CENTER

Record of Changes (changes are indicated by \1\ ... /1/)

Change No.	Date	Location
1	April 1, 2019	<u>1-4, ccr 4719, 1-5.5 ccr 5512, 2-3.4.1 ccr 4720,3-1.1 ccr 6625, 2-6 ccr 7378, 2-8 ccr 4721 and ccr 4722, 3-6.5 ccr 4723, Figure 3-13 ccr 4724, 3-15.1.2 ccr 4726, 4-2.1 ccr 4727, 4-3.1.5 ccr 4728,4-4.4 ccr 4729</u>

This UFC supersedes UFC 4-440-01A, dated March 1, 2005 and UFC 4-442-01N, dated January 16, 2004.

FOREWORD

The Unified Facilities Criteria (UFC) system is prescribed by MIL-STD 3007 and provides planning, design, construction, sustainment, restoration, and modernization criteria, and applies to the Military Departments, the Defense Agencies, and the DoD Field Activities in accordance with [USD \(AT&L\) Memorandum](#) dated 29 May 2002. UFC will be used for all DoD projects and work for other customers where appropriate. All construction outside of the United States is also governed by Status of Forces Agreements (SOFA), Host Nation Funded Construction Agreements (HNFA), and in some instances, Bilateral Infrastructure Agreements (BIA.) Therefore, the acquisition team must ensure compliance with the most stringent of the UFC, the SOFA, the HNFA, and the BIA, as applicable.

UFC are living documents and will be periodically reviewed, updated, and made available to users as part of the Services' responsibility for providing technical criteria for military construction. Headquarters, U.S. Army Corps of Engineers (HQUSACE), Naval Facilities Engineering Command (NAVFAC), and the Air Force Civil Engineer Center (AFCEC) are responsible for administration of the UFC system. Defense agencies should contact the preparing service for document interpretation and improvements. Technical content of UFC is the responsibility of the cognizant DoD working group. Recommended changes with supporting rationale should be sent to the respective service proponent office by the following electronic form: [Criteria Change Request](#). The form is also accessible from the Internet sites listed below.

UFC are effective upon issuance and are distributed only in electronic media from the following source:

- Whole Building Design Guide web site <https://www.wbdg.org/>.

Hard copies of UFC printed from electronic media should be checked against the current electronic version prior to use to ensure that they are current.

AUTHORIZED BY:

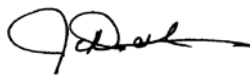

JAMES C. DALTON, P.E.
Chief, Engineering and Construction
U.S. Army Corps of Engineers



JOSEPH E. GOTT, P.E.
Chief Engineer
Naval Facilities Engineering Command



JOE SCIABICA, SES
Director
Air Force Civil Engineer Center



MICHAEL McANDREW
Director, Facilities Investment and Management
Office of the Deputy Under Secretary of Defense
(Installations and Environment)

**UNIFIED FACILITIES CRITERIA (UFC)
NEW SUMMARY SHEET**

Document: UFC 4-440-01, *WAREHOUSES AND STORAGE FACILITIES*

Superseding: UFC 4-440-01A *Storage Depots* and UFC 4-442-01N *Design: Covered Storage*.

Description: This new UFC, "*WAREHOUSES AND STORAGE FACILITIES*" replaces UFC 4-440-01A, *Storage Depots* (Army) and UFC 4-442-01N, *Design: Covered Storage* (Navy). These existing UFCs are not unified. The Army document is former TM 5-840-02 dated October 7, 1994. The Navy document is former Military Handbook 1032/2 dated September 30, 1987.

Reasons for Document:

- The new UFC will provide updated guidance for new warehouses and covered storage facilities.

Impact:

- The result of these changes is a document which can more practically be used as part of a construction contract and is more easily understood by the users, more relevant to current practice and is properly coordinated with other Government requirements documents.

Non-Unified Items:

- Differing policies for Navy and Marine Corps, Army, and Air Force appear in paragraphs entitled "*Controlled Humidity Warehouse*", "*Flammable / Hazardous Storage Within Other Storage Facilities*", and "*Flammable / Hazardous Materials Storage*".

TABLE OF CONTENTS

CHAPTER 1 INTRODUCTION	1
1-1 PURPOSE AND SCOPE.....	1
1-2 APPLICABILITY.....	1
1-2.1 Conflicts in Criteria.....	1
1-3 GENERAL BUILDING REQUIREMENTS	1
1-4 TYPES OF STORAGE FACILITIES.....	2
1-4.1 General Purpose Warehouse	2
1-4.2 Humidity Controlled Warehouse	2
1-4.3 Shed Storage.....	3
1-4.4 Hazardous Materials Storage within Other Storage Facilities	3
1-5 EXCLUSIONS	3
1-5.1 Cold Storage.....	3
1-5.2 Liquid Storage.....	4
1-5.3 Ammunition Storage	4
1-5.4 Open Storage	4
1-5.5 Hazardous Waste Storage.....	4
1-6 APPENDICES	4
CHAPTER 2 PLANNING AND LAYOUT.....	5
2-1 PROJECT INITIATION AND PLANNING.....	5
2-1.1 Project Analysis and Engineering Phase	5
2-2 GEOGRAPHIC PLANNING.....	5
2-3 STORAGE / HANDLING SYSTEM	6
2-3.1 Design Parameters	6
2-3.2 Procedures	6
2-3.3 Material Handling Equipment.....	11
2-3.4 Storage Equipment.....	11
2-4 MATERIAL HANDLING SYSTEMS CONSIDERATIONS.....	13
2-4.1 Receiving Shipping Operations.....	13
2-4.2 Order Picking Operations.....	13
2-5 SUPPORT AREAS.....	14
2-5.1 Supervisory Offices.....	15
2-5.2 Receiving Office.....	15

2-5.3	Shipping Office	17
2-5.4	Rest Rooms	18
2-5.5	Employee Services	18
2-5.6	Crating Operations.....	18
2-5.7	Packing/Packaging Operations.....	18
2-5.8	Battery Charging Area	18
2-6	PARKING	19
2-7	TRAFFIC FLOW.....	19
2-8	SAFETY.....	19
CHAPTER 3	GENERAL DESIGN CRITERIA.....	21
3-1	GENERAL DESIGN FACTORS	21
3-1.1	Material Movement	21
3-1.2	Expansion Capability	21
3-1.3	Flexible Design	21
3-1.4	Requirements of Specific Buildings	21
3-2	BUILDING SHAPE AND PROPORTIONS.....	23
3-2.1	Travel Distance.....	23
3-2.2	Irregular Shapes	23
3-2.3	Height	23
3-2.4	Area	23
3-3	BUILDING SPACING	23
3-3.1	Rail Side	23
3-3.2	Truck Side.....	23
3-3.3	Warehouses In-Line.....	24
3-3.4	Hazardous Materials Facilities	24
3-4	DOCKING FACILITIES	24
3-4.1	Truck Dock.....	27
3-4.2	Rail Docks.....	33
3-4.3	Ramp Access.....	34
3-4.4	Dock Levelers	34
3-4.5	Dock and Platform Weather Protection.....	35
3-4.6	Safety Equipment	37
3-5	STRUCTURAL	39

3-5.1	Ground Floors.....	39
3-5.2	Superstructure	39
3-6	EXTERIOR DESIGN.....	43
3-6.1	Surface Treatment.....	43
3-6.2	Roofing Systems.....	43
3-6.3	Exterior Walls.....	44
3-6.4	Dock Doors	44
3-6.5	Fire Doors	45
3-6.6	Windows	45
3-6.7	Doors and Hardware.....	45
3-6.8	Signage.....	45
3-7	INTERIOR DESIGN.....	46
3-7.1	Interior Walls.....	46
3-7.2	Doors and Windows.....	46
3-7.3	Signage.....	47
3-7.4	Warehouse Storage Area	47
3-7.5	Shops and Storage Rooms.....	50
3-7.6	Administration and Office Spaces.....	50
3-7.7	Toilet and Locker Rooms.....	51
3-7.8	Corridors and Stairs.....	51
3-7.9	Support Spaces	52
3-7.10	Battery Charging and Handling Operations	52
3-7.11	Pallet Racks.....	57
3-7.12	Aisle Dimensions	64
3-7.13	Building Bay Dimensions	66
3-7.14	Telecommunication Systems.....	70
3-7.15	Alarm Systems.....	70
3-7.16	Casework.....	70
3-7.17	Elevators and Lifts	71
3-7.18	Furniture Considerations.....	71
3-7.19	Equipment Considerations.....	71
3-8	PEST CONTROL.....	71
3-9	ACCESSIBILITY FOR THE DISABLED.....	72

3-10	ACOUSTICS.....	72
3-11	CONVEYING SYSTEMS	72
3-11.1	Overhead Bridge Cranes	72
3-12	MOTOR AND CONTROLS.....	73
3-13	PLUMBING.....	73
3-13.1	General.....	73
3-13.2	Compressed Air	73
3-14	ENVIRONMENTAL CONTROL.....	74
3-14.1	General.....	74
3-14.2	Heating	74
3-14.3	Ventilation.....	75
3-14.4	Humidity Control	76
3-14.5	Air Conditioning	76
3-14.6	Energy Conservation	76
3-14.7	Insulation	76
3-14.8	Mechanical Equipment Requirements	76
3-14.9	Noise and Vibration Control.....	77
3-15	FIRE PROTECTION	77
3-15.1	Fire Protection Sprinkler Systems.....	77
3-15.2	Fire Alarm Systems	78
3-15.3	Smoke Detectors	78
3-16	ELECTRICAL	80
3-16.1	Power.....	80
3-16.2	Emergency Power	80
3-16.3	Lighting	80
3-16.4	Receptacles.....	81
3-16.5	Battery Chargers.....	81
3-16.6	Lightning Protection	81
3-17	CIVIL.....	81
3-17.1	Siting.....	81
3-17.2	Utilities	82
3-17.3	Utility Metering	82
3-18	SUSTAINABLE DESIGN.....	82

CHAPTER 4 HAZARDOUS MATERIALS STORAGE GENERAL DESIGN CRITERIA		83
4-1	GENERAL	83
4-2	HAZARDOUS MATERIALS STORAGE	83
4-2.1	Compliance Standards	83
4-2.2	Hazardous Materials Storage	83
4-2.3	Design Criteria	84
4-2.4	Storage Requirements	84
4-2.5	Material Handling Equipment	84
4-3	SEGREGATION OF MATERIALS	85
4-3.1	Categories of Materials	85
4-3.2	Segregation Requirements	86
4-3.3	Combined Shed Storage	88
4-4	SPILL CONTAINMENT AND CONTROL	88
4-4.1	Exterior Containment	88
4-4.2	Interior Containment	88
4-4.3	Dikes	89
4-4.4	Floor Trenches and Capture Systems	89
4-4.5	Recessed Floor	92
4-4.6	Containment	92
4-4.7	Drainage	92
APPENDIX A REFERENCES		93
APPENDIX B BEST PRACTICES		99
B-1	GENERAL	99
B-2	WHOLE BUILDING DESIGN GUIDE	99
B-3	FACILITY DESIGN	99
APPENDIX C GLOSSARY		101

FIGURES

Figure 2-1	System Selection Flowchart	7
Figure 2-2	Standard Pallet Rack Elevation / Parameters.....	9
Figure 2-3	Typical Receiving Office Layout - Functional Dimensions	16
Figure 2-4	Typical Shipping Office Layout - Functional Dimensions.....	17
Figure 2-5	Typical Safety Markings	20
Figure 3-1	Truck Apron Criteria (Functional Dimensions).....	25
Figure 3-2	Building Protection Devices	26
Figure 3-3	Truck Dock Configurations	29
Figure 3-4	Typical Truck Dock.....	30
Figure 3-5	Truck Apron Section.....	31
Figure 3-6	Door Size Characteristics	32
Figure 3-7	Rail Car Characteristics.....	33
Figure 3-8	Truck Dock Weather Seals.....	36
Figure 3-9	Truck Dock Canopy	37
Figure 3-10	Trailer Restraint System	38
Figure 3-11	Battery Charging Area (Open Locations).....	53
Figure 3-12	Battery Charging Area (One-Entrance Room).....	54
Figure 3-13	Typical Battery Charger Installation.....	56
Figure 3-14	Pallet Rack Terminology.....	58
Figure 3-15	DoD Pallet Arrangement.....	59
Figure 3-16	Pallet Rack Fire Protection Terminology	61
Figure 3-17	Pickup and Delivery (P&D) Stations	63
Figure 3-18	Typical Rail Guidance System.....	64
Figure 3-19	Typical Wire Guidance System	65
Figure 3-20	Building Column Spacing Parameters	66
Figure 3-21	Standard Face and Longitudinal Flue Sprinkler Mounting.....	79
Figure 4-1	Hazardous Materials Storage Segregation Layouts	87
Figure 4-2	Spill Capture/Containment System.....	90
Figure 4-3	Electronic Guide Wire Crossing.....	91

TABLES

Table 2-1	Administrative and Supervisory Offices and Support Area Space Requirements.....	14
Table 3-1	Special requirements for Warehouse Types.....	22
Table 3-2	Truck and Rail Vehicle and Dock Heights	28
Table 3-3	Dock Leveler Life (Years) Based on Impact Loading.....	35
Table 3-4	Recommended Door and Portal Sizes	44
Table 3-5	Building Bay Size Comparison	68
Table 3-6	Required Clear Building Heights	69

CHAPTER 1 INTRODUCTION

1-1 PURPOSE AND SCOPE.

This Unified Facilities Criteria (UFC), UFC 4-440-01, contains criteria for planners, engineers, and architects on the planning, engineering, and design of Department of Defense (DoD) storage facilities. The information in this UFC applies to the design of all new construction projects, to include additions, alterations, and renovation projects in the continental United States (CONUS) and outside the continental US (OCONUS). Alteration and renovation projects must update existing facilities to meet the guidance and criteria contained in this UFC within budgetary constraints. This is supplementary guidance to be used in conjunction with Facility Requirements Documents (FRD), Facility Requirements Supplements (FRS), Intrusion Detection Systems Engineering Plans (IDSEP), Installation Appearance Plan (IAP), and other DoD material for the planning and construction of DoD storage facilities and to support the preparation of DD 1391 project documentation.

1-2 APPLICABILITY.

This UFC will be used for planning individual projects, preparing engineering documentation, and preparing contractual documents for construction. It is intended to present the basis for standardization of practices and identify a common baseline to be used during the planning of new facilities or the modification of existing facilities.

1-2.1 Conflicts in Criteria

Where conflicts appear between the general criteria contained in the Whole Building Design Guide (WBDG) website and the guidance in this document, the guidance in this UFC governs.

Exception: Navy and Marine Corps planning criteria is governed by UFC 2-000-05N, *(P-80) Facility Planning Criteria for Navy/Marine Corps Shore Installations*. Conflicts must be brought to the attention of the UFC 2-000-05N program manager through a Criteria Change Request (CCR). To submit a CCR go to the following link: <https://cms.wbdg.org/ccrs/new?ufc=2-000-05N>

1-3 GENERAL BUILDING REQUIREMENTS

Comply with UFC 1-200-01, *General Building Requirements*. UFC 1-200-01 provides applicability of model building codes and government unique criteria for typical design disciplines and building systems, as well as for accessibility, antiterrorism, security, high performance and sustainability requirements, and safety. Use this FC in addition to UFC 1-200-01 and the UFCs and government criteria referenced therein.

1-4 TYPES OF STORAGE FACILITIES

The criteria in this UFC cover the design requirements for warehouse facilities; General Purpose Warehouse, Controlled Humidity Warehouse, \1\ Hazardous Materials Storage, /1/ and Shed Storage, or the combination of these storage facility types. These criteria address the factors which affect the functional effectiveness of warehouse facilities. Included in these factors are siting, system selection, facility layout, area, storage height, life-cycle costs, energy efficiency, and internal details. Since modern storage facilities are integrated operations in which the structure and materials handling/ storage equipment function as a system, coordination and integration of equipment and structure requirements is essential to proper operation of the system. The more common facility types following:

1-4.1 General Purpose Warehouse

General Purpose Warehouse includes, conditioned, semi-conditioned, and unconditioned types, with and without overhead crane capability. The general purpose warehouse provides space for bulk and bin storage, aisle space, receiving and shipping space, packing and crating space, and office and toilet space.

1-4.2 Humidity Controlled Warehouse

A humidity controlled warehouse is similar to a general purpose warehouse except that it is designed with enhanced features for humidity control, such as: humidity control equipment and enhanced building envelope design. This warehouse may be a separate building or contiguous with a general purpose warehouse. Requirements for controlled humidity space must be thoroughly justified. Such requirements must be considered a portion of the total space allowed for the facility type. Use DoD Real Property Classification System (RPCS); Category Codes 441-10 through 441-40 facility types. Planning for storage of material in controlled humidity space for varying periods of time is authorized when the use of such space performs the following:

- a. Permits technical material and material highly sensitive to moisture to be stored in a state of readiness for immediate issue.
- b. Permits a reduction in the cost in initial preservation or re-preservation of material.
- c. Affords significant reduction in either the reactivation time or the reactivation cost of material, or both.
- d. Maintains the condition of any material being held in temporary storage while awaiting repair, disposition, preservation or re-preservation, or assembly of components.
- e. Affords the desired supplemental protection to material already subjected to preservation treatment

1-4.3 Shed Storage

A shed is a roofed structure without complete side or end walls. Sheds are typically used for storage of gas cylinders, drummed Petroleum/Oil/Lubricant (POL), vehicles, unfinished lumber, and other construction material. In areas where it is impractical to use shed space for the storage of materials because of weather conditions, storage requirements must be included as warehouse space and complete justification must be submitted. Sheds storing hazardous materials are subject to special design requirements and must comply with criteria in Chapter 4 of this UFC.

1-4.3.1 General Purpose Shed

Provide minimum utilities consisting of electricity for lighting and electrically operated equipment and tools. Provide fire protection in proportion to the type of material stored and the loss potential.

1-4.4 Hazardous Materials Storage within Other Storage Facilities

Hazardous materials warehouses differ significantly from general purpose warehouses due to the materials stored and the provisions made to prevent, and remove through proper ventilation, mists, gases, and vapors in accordance with National Fire Protection Association (NFPA) *Flammable and Combustible Liquids Code*, NFPA 30 and NFPA 430, *Code for the Storage of Liquid and Solid Oxidizers*. Materials considered for storage in this category facility include paints, certain packaged Petroleum/Oil/Lubricant (POL) materials, chemicals, acids, corrosive liquids, oxidizing materials, and other similar hazardous flammable materials. Space justified for hazardous materials storage must be considered a portion of the total space allowed for the facility type. Such space must not exceed 5 percent of the total space. Such flammable and combustible liquid storage area(s) must comply with the requirements of Chapter 4 of this UFC.

Use DoD Real Property Classification System (RPCS); Category Codes 441-10 through 441-40 facility types.

1-5 EXCLUSIONS

Design of the following types of storage facilities is not covered by this UFC:

1-5.1 Cold Storage

Cold storage warehousing is planned to satisfy the primary function of preservation of the quality of perishable foods and general supply materials that require refrigeration. The warehouse will include freeze and chill space, processing facilities, and mechanical areas. Cold Storage warehouses are not included. See Unified Guide Specification (UFGS) 11 41 11, *Refrigerated and Frozen Food Storage Equipment* for additional guidance.

1-5.2 Liquid Storage

Bulk tanks and associated equipment for liquid fuel storage and storage of liquids other than water, fuel tanks, and propellant tanks are not included. Refer to UFC 3-460-01, *Design: Petroleum Fuel Facilities*.

1-5.3 Ammunition Storage

Magazines, specialized warehouses, tanks, and open pads for storage of ammunition, inert ammunition components, liquid propellants, and weapon related batteries are not included.

1-5.4 Open Storage

Non-covered storage areas, paved or otherwise are not included.

1-5.5 Hazardous Waste Storage

Facilities which are used for storage of hazardous waste or are otherwise subjected to the requirements of 40 Code of Federal Regulations (CFR) *Protection of Environment, Part 264 Standards for Owners and Operators of Hazardous Waste Treatment, Storage, and Disposal Facilities* \1V1/are not included.

1-6 APPENDICES

Appendix A contains a list of references used in this document. The publication date of the code or standard is not included in this document. In general, the latest available issuance of the reference is used.

Appendix B identifies background information and best practices for accomplishing design and engineering services.

Appendix C contains acronyms, abbreviations, and terms.

CHAPTER 2 PLANNING AND LAYOUT

2-1 PROJECT INITIATION AND PLANNING

This UFC provides information required for preparation of DD Form 1391, which initiates project development. This includes information about functions, space allowances, overall building size, site evaluation, and special factors to consider in developing overall scope and cost estimates. It provides data and criteria needed at each stage of planning, project engineering, and the design process.

2-1.1 Project Analysis and Engineering Phase

After a project is initiated, it is analyzed and defined. During the Project Analysis stage, the project team meets to define the project so as to have a clear understanding of the project goals and objectives. The Customer, Design Agent, and Architect / Engineer (A/E) team then develops the project documentation based on an analysis of unique customer needs, requirements, established criteria, and site and environmental constraints. Information gathered provides the basis for defining the preliminary design and supports the project engineering phase, parametric cost estimating (PCE), and programming process. Information required includes space planning, site design, selection of the appropriate plan, water supply, and building design, elements and concepts. Unique local requirements concerning building program and design criteria are included in the PCE.

Functional concept planning for new facilities or modernization of existing facilities must include guidance and information contained in this document and data from reference documents identified in this publication.

2-1.1.1 Antiterrorism

Antiterrorism requirements are established as part of the design program and are identified as a separate line item in the DD Form 1391 estimate.

2-1.1.2 Navy and Marine Corps

Navy and Marine Corps planning criteria is governed by UFC 2-000-05N, *(P-80) Facility Planning Criteria for Navy/Marine Corps Shore Installations*.

2-2 GEOGRAPHIC PLANNING

Planning and design of warehouse facilities must address the specific climatic and geographic conditions of the intended site. In all climate regions consider solar orientation to maximize energy efficiency, passive solar and daylighting potential of the building. Refer to UFC 1-200-02, *High Performance and Sustainable Building Requirements*.

2-3 STORAGE / HANDLING SYSTEM

New facilities or modernization of existing facilities must consider the evaluation of alternative materials handling systems, selection of handling and storage equipment, design of operations, and layout of the building.

2-3.1 Design Parameters

The following design parameters must be observed when collecting data and analyzing requirements associated with the material storage and handling requirements of a planned warehouse facility:

2-3.1.1 Load Size

Standard cargo load size (including pallet) is 40 inches x 48 inches x 36 inches high (1020 millimeters [mm] x 1220 mm x 915 mm), or 40 cubic feet (ft³) (1.13 cubic meters [mm³]) which is equal to 1 Measurement Ton (M/T). The average storage load is 0.8 M/Ts (32 ft³, 0.91 mm³) which equates to a pallet size 40 inches x 48 inches x 28.8 inches (1020 mm x 1220 mm x 730 mm). A 48-inch (1220 mm) vertical pallet rack beam spacing is provided by the standard pallet rack configuration for this average height load. Maximum DOD allowances for loaded pallets with overhanging loads are 43 inches x 52 inches (1090 mm x 1320 mm). Planning must accommodate such vertical dimensions or be adjusted where loads differ significantly from the average height. In special cases such as automated storage/retrieval system racks, it may be necessary to maintain the 40-inch x 48-inch (1020 mm x 1220 mm) dimensions due to equipment restrictions.

2-3.1.2 Cost Standards

Storage costs, handling costs, and handling times relative to actual performance of an activity must be evaluated before comparisons are made between proposed designs and current operations if applicable.

2-3.1.3 Storage Height

Economical storage height is dictated by safety requirements, site restrictions, foundation cost, aviation restrictions, materials handling equipment availability, and storage requirements. These characteristics must be considered when making system evaluations.

2-3.1.3.1 Hazardous Materials Warehouses Storage Height

Hazardous materials warehouses are limited to a maximum storage height of 25 feet (7620 mm) or less. See the paragraph entitled "Material Handling Equipment".

2-3.2 Procedures

The following steps should be followed in developing a facility concept. Figure 2-1 illustrates these steps in flowchart form. The Activity or Project Manager must

designate in the project scope the following factors, as well as any special requirements for storage or handling.

Figure 2-1 System Selection Flowchart

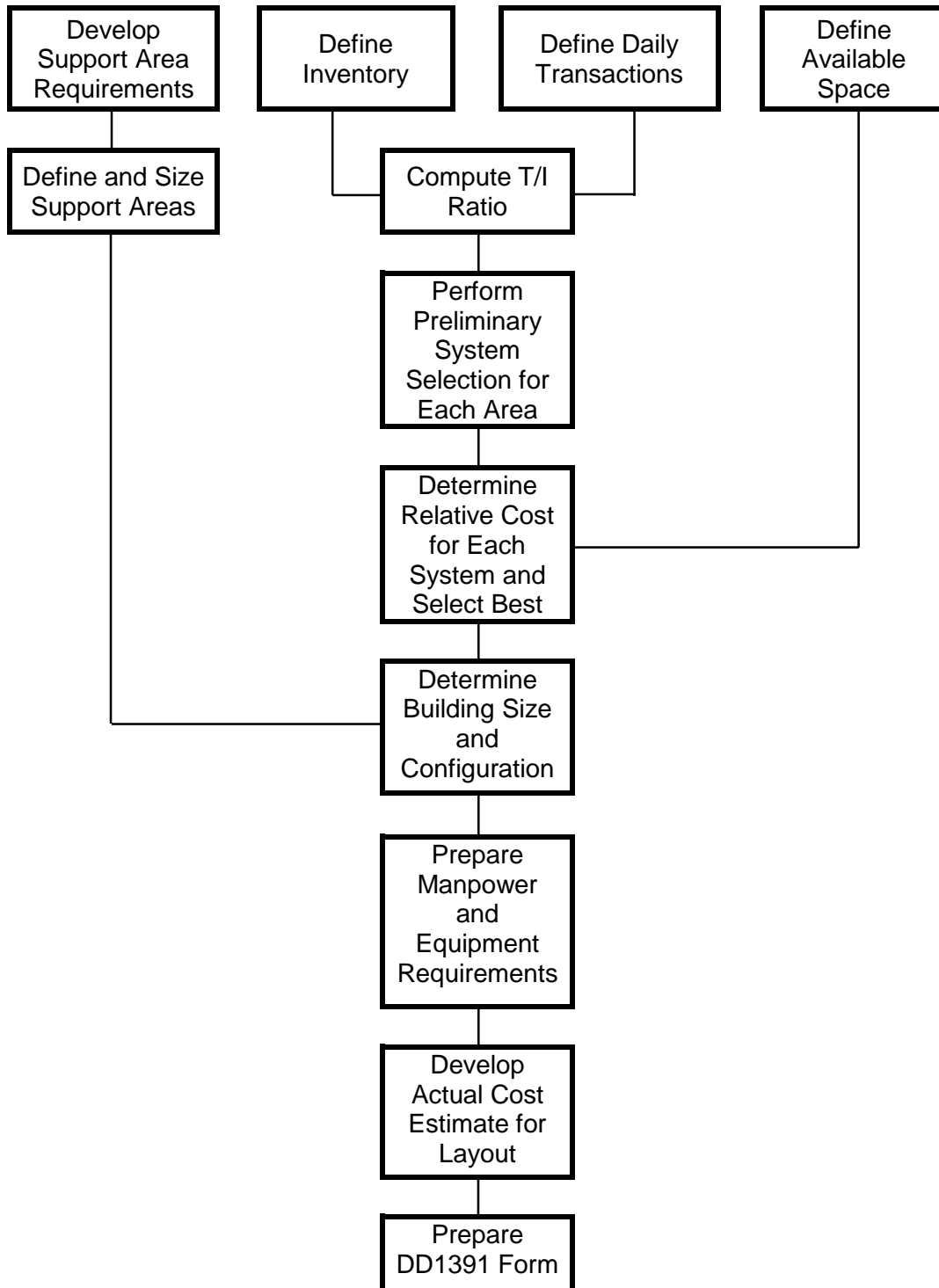

2-3.2.1 Define Inventory

State inventory levels in terms of 0.80 measurement ton (m/t) (32 ft³ or 0.91 m³) pallet loads or 0.0095 m/t (0.38 cubic foot; 0.011 cu. M) shelf boxes. Separate inventory into groups with similar storage, handling, or transaction characteristics. The major inventory item attributes to be evaluated must include temperature sensitivity, hazardous characteristics, stackability, dimension, volume, and weight. Examples are pallet storage, bin storage, high and low activity material, pre-positioned war reserve stocks, etc. Establish maximum/minimum inventory levels per group.

2-3.2.2 Define Daily Transactions

Define daily activity characteristics of each inventory group. For pallet systems activity levels must be defined in terms of daily quantities of pallets stored and retrieved. Define daily activity for binnables and rackables order picking systems in a line item (stock keeping unit) format.

2-3.2.3 Define Available Space

Define the space available for system installation for both new facility designs and conversion of existing facilities. Determine available Net Square Feet (NS) and allowable Stacking Height (SH) to define the available storage area in terms of Total Cubic Feet (TCF). When determining Stacking Height, the allowable stacking load, floor load capacity, and floor condition (surface condition, expansion joints, cracks, and flatness) must be considered. Figure 2-2 shows a typical height pattern for pallet racks up to the limit of the stacking capability of standard forklift equipment.

Figure 2-2 Standard Pallet Rack Elevation / Parameters

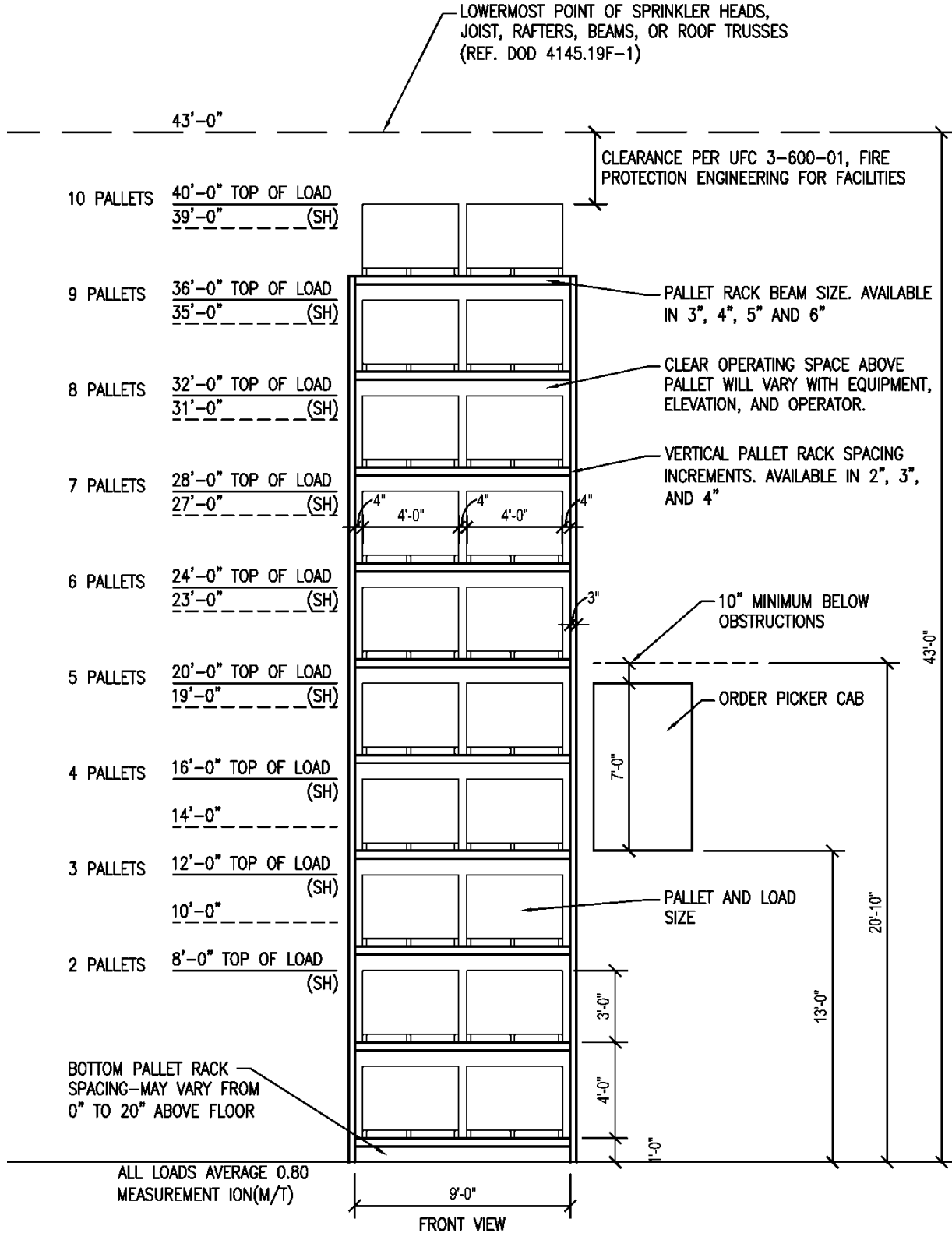

2-3.2.4 Compute Transaction/Inventory (T/I) Ratio

Compute the system T/I ratio based upon the defined inventory and transaction quantities. Develop separate T/I ratios for each inventory or handling group identified by the procedure in the paragraph entitled "Define Inventory".

2-3.2.5 Select System

Taken together, physical characteristics of inventory and storage facility narrow the range of acceptable materials handling systems. Identify requirements or limitations which will affect system operations. Evaluate and perform preliminary system selections based on the computed T/I ratios for each area or inventory group. Evaluate and identify alternative systems for each area.

2-3.2.6 Determine Cost

Determine the relative cost for each system and select the most effective system for the funds available.

2-3.2.7 Determine Covered Storage Area

Determine the required building area for the selected system(s). Include cube and stacking height values as per UFC 2-000-05N (P-80) *Facility Planning Criteria for Navy and Marine Corps Shore Installations*.

2-3.2.8 Determine Support Area Requirements and Sizes

Evaluate and develop Support Area requirements. Support Areas consist of all other warehouse areas other than the Storage Area (SA). These include support functions such as supervisory offices, receiving, shipping, rest rooms, employee services, crating operations, packing/ packaging operations, battery charging rooms, inspection, identification, preservation, training rooms, mechanical equipment rooms, etc. Define and size Support Areas based on manpower and equipment requirements per each space and function.

2-3.2.9 Integrate Layout

Develop a composite building layout by integrating the various storage and support areas into a facility layout. Incorporate functional adjacency requirements of spaces. If the Storage Area includes hazardous materials storage the facility layout must take into account separation/safety considerations. Hazardous materials storage areas must be isolated in combination layouts. Combine the separate operations into a composite facility plan by adjusting column spacing to produce a common dimension while maintaining compatibility among the various systems. Explore 3 different layouts to ensure pre-construction system optimization.

2-3.3 Material Handling Equipment

The following materials handling equipment are essential components of warehouse facilities and their characteristics must be considered during the design phase.

2-3.3.1 Pallet Handling Equipment

This equipment may be either vehicular (truck-like) or specifically designed (i.e., storage/retrieval machine) for transporting and storing the standard pallet.

2-3.3.1.1 Fork Trucks

Propane, gas or diesel powered fork trucks can have a significant impact on ventilation requirements and indoor usage must be avoided where practical. Facilities are to be designed so that no gasoline, diesel or LPG/Propane fueled fork trucks are permitted to be used for prolonged periods of time. These types of fork trucks are to make quick drop-offs of material and electric fork trucks should move the stock within the warehouse facility.

When gasoline, diesel or LPG/Propane fueled fork trucks are required by the user activity the ventilation and/or climate control systems must be design to accommodate the expected quantity of fork trucks and duration of indoor use. Refueling for these types of fork trucks must be provided on the exterior of the building. Provide a spill containment dike for gasoline and diesel fork trucks in accordance the paragraph entitled "*Dikes*".

2-3.3.1.2 Conveyer Systems

Conveyer Systems must be selected and designed to achieve energy conservation goals. They must include controls to automatically shut-down to conserve energy when not in use for a preset period of time. High efficiency, variable speed motors with "soft start" functions must be utilized to conserve energy and minimize maintenance.

2-3.3.2 Order Picking Equipment

This equipment is designed to aid a worker in the selection and transportation of supplies and may be vehicle based or designed as an application specific piece of equipment.

2-3.3.3 Transport Systems

These systems are designed for the movement of supplies between two or more locations within or outside of a facility. They may be designed to transport packaged loads (pallets or shelf boxes), loose loads, bulk liquids, or solids.

2-3.4 Storage Equipment

The following types of storage equipment are essential components of warehouse facilities and their characteristics must be considered during the design phase.

Storage equipment will be provided to store materials properly, off the floor. It will also be securely fastened to the slab and/or other structural supports designed to support the equipment per equipment manufacturer's installation requirements. Storage equipment will be protected by proper means from contact by material handling and operational equipment.

2-3.4.1 Pallet Rack

Pallet racks must be designed for safe storage of palletized loads based on the standard pallet as described in the paragraph entitled "Load Size". Designs for other size pallets may be used in conjunction with appropriately sized pallet racks and pallet handling fork lift equipment. These include double-deep racks, cantilever racks, drive-in and drive thru rack systems, side-loading fork lifts, and double-reach fork lifts. Idle pallets must be stored in accordance with NFPA 230 and sprinkler protection provided in accordance with NFPA 13. /1/

2-3.4.2 Shelving/Bins

Shelving and bins are designed for storage of package type items in less than pallet load quantities. Industrial grade steel shelving and storage bins are modular in nature and are composed of front and rear upright posts, shelves, dividers. Bin storage units are a sub-group of industrial shelving in which the storage shelves are divided into smaller compartments. If a shelf is divided into two or more compartments, the compartments are classified as bins.

2-3.4.2.1 Shelving

Shelving is used for economical storage of small hand stackable items which are not suited to mechanized handling and storage due to their handling characteristics, activity, or quantity. Shelving is most often used for small parts storage in order picking systems and is suitable for either manual or mechanized operations.

Shelving is generally available in standard unit heights of 85 to 87 inches (2160mm to 2210mm) and a unit width of 36 inches (914mm). Typical depths are 12 inches (304mm), 18 inches (457mm), and 24 inches (609mm). The range of widths varies from 24 to 48 (609mm to 1220mm) inches while the depth ranges from 9 to 36 inches (228mm to 914mm). Shelf uprights are available in either beaded post or angle post configurations. Shelving is available in either open or closed design. Closed design includes solid back and side panels which provide load containment and minimize possible accumulation of unwanted dust and dirt. Open shelving is less expensive and utilizes sway braces to provide rigidity.

2-3.4.2.2 Bins

Bin storage is, in most instances, identical in application to shelf storage but is generally applied to smaller items which do not need the entire width of a conventional shelf module. Bin storage represents a small part of the total storage system in terms of physical space although it may represent a significant portion of the total storage in terms of item positions.

2-3.4.3 Special

Special storage equipment consists of devices designed for specific purposes such as cantilever rack, vertical sheet storage rack, pallet stacking frames, rigid and collapsible metal bins, etc.

2-3.4.4 Installation and Operation Tolerances

Observe the following tolerances for installation and operation of storage equipment. These tolerances apply in the absence of more stringent manufacturer tolerances.

- a. Plumbness of pallet racks and high rise shelving +/- 1/16 inch (+-1.6 mm) over total height.
- b. Pallet rack beam elevation +/-1/4 inch (+-6.4 mm) between adjacent beams.
- c. Rail guide position +1/4, -0 inches (+6.4 mm, -0 mm) from specified rail spacing.
- d. Wire guide position +/-1/4 inch (+-6.4 mm) from specified centerline.
- e. Pallet rack aisle spacing +/-1/4 inch (+-6.4 mm) from design aisle width.
- f. Down-aisle rack offset +/-1/4 inch (+-6.4 mm) from aisle centerline.

2-4 MATERIAL HANDLING SYSTEMS CONSIDERATIONS

2-4.1 Receiving Shipping Operations

Review vehicle and material flow characteristics, including:

- a. Types of vehicles to be serviced.
- b. Location of rail and road access.
- c. Location with respect to other facility operations.
- d. Support area requirements, such as staging areas and offices.

2-4.2 Order Picking Operations

Review load and documentation requirements, including:

- a. Type of product being processed.
- b. Documentation requirements.

c. Packing/packaging requirements.

2-5 SUPPORT AREAS

Separate support areas from hazardous materials storage areas with a 2-hour fire wall and from combustible or flammable storage areas with a 4-hour fire wall. Direct access between support areas and hazardous materials storage areas is not permitted. Refer to table 2-1 for space estimating criteria for administrative and supervisory offices. Refer to UFC 2-000-05N (P80), *Facilities Planning Criteria for Navy and Marine Corps Shore Installations* for criteria relating to other warehouse support functions.

Table 2-1 Administrative and Supervisory Offices and Support Area Space Requirements

LOCATION	LENGTH		WIDTH		AREA	
	m	ft	m	ft	m	ft
Private Offices						
Warehouses Manager	6.1	20	4.9	16	29.7	320
Personnel Manager	4.3	14	3.7	12	15.6	168
Open Office Dividers						
Managers	3.7	12	3.7	12	13.4	144
Assistants	3.0	10	2.4	8	7.4	80
Secretaries	2.4	8	2.4	8	5.9	64
Accounts Payable	1.5	5	2.1	7	3.3	35
Inventory Control	1.5	5	2.1	7	3.3	35
Procurement	1.8	6	2.4	8	4.5	48
Operations	1.8	6	1.8	6	3.3	36
Meeting Area	3.0	10	3.0	10	9.3	100
Interview Area	2.4	8	2.4	8	5.9	64
Programmers	2.4	8	2.4	8	5.9	64
Open Support Services						
Files	0.3	1	1.5	5	0.5	5
Reception/Lobby Area	9.1	30	6.1	20	55.7	600
Main Aisles (1)	--	--	--	--	--	--
Secondary Aisles (2)	--	--	--	--	--	--
Photocopy Machine	1.8	6	1.2	4	2.2	24
Closed Support Services						
Mail Room	7.6	25	3.7	12	27.9	300
Restrooms	7.3	24	2.4	8	17.8	192
Janitorial Closet	1.8	6	1.2	4	2.2	24
Clothes Closet	3.0	10	0.6	2	1.8	20
Supply Room	5.5	18	3.7	12	20.1	216
Computer Room	7.6	25	6.1	20	46.5	500
Conference Room	7.6	25	6.1	20	46.5	500
Lunch/Break Room (3)	18.3	60	6.1	20	111.5	1200
First-Aid Room	4.9	16	3.7	12	17.8	192

Areas considered for support of a storage facility include the following:

2-5.1 Supervisory Offices

Provide offices for supervisory personnel such as foremen, crew leaders, etc. Offices must accommodate two people and provide filing space, one desk, and two chairs per person. Offices must be located near their associated activity areas. Offices may consist of prefabricated partition-type enclosures or more permanent forms of construction such as concrete block.

Separate shipping and receiving office areas may be required in larger facilities and combined hazardous materials and general storage facilities for safe operation and to expedite the flow of paperwork associated with the increased activity. A facility with few employees may use a single multipurpose office located away from any hazardous materials storage area. Office location and arrangement must provide separation of work functions and maintain security by controlling access to the facility. Offices must permit an unobstructed view of the inside and outside dock areas. Rest room facilities for both truck drivers and employees may be integrated into the office design.

2-5.2 Receiving Office

The typical functional area relationships for the Administration and Warehouse Facilities provide space for a building and site security system and office space for receiving personnel. The secured entrance, lobby and rest room for truck drivers provides controlled entry into the facility. Separate rest rooms are provided for supervisory and warehouse personnel. See figure 2-3.

Figure 2-3 Typical Receiving Office Layout - Functional Dimensions

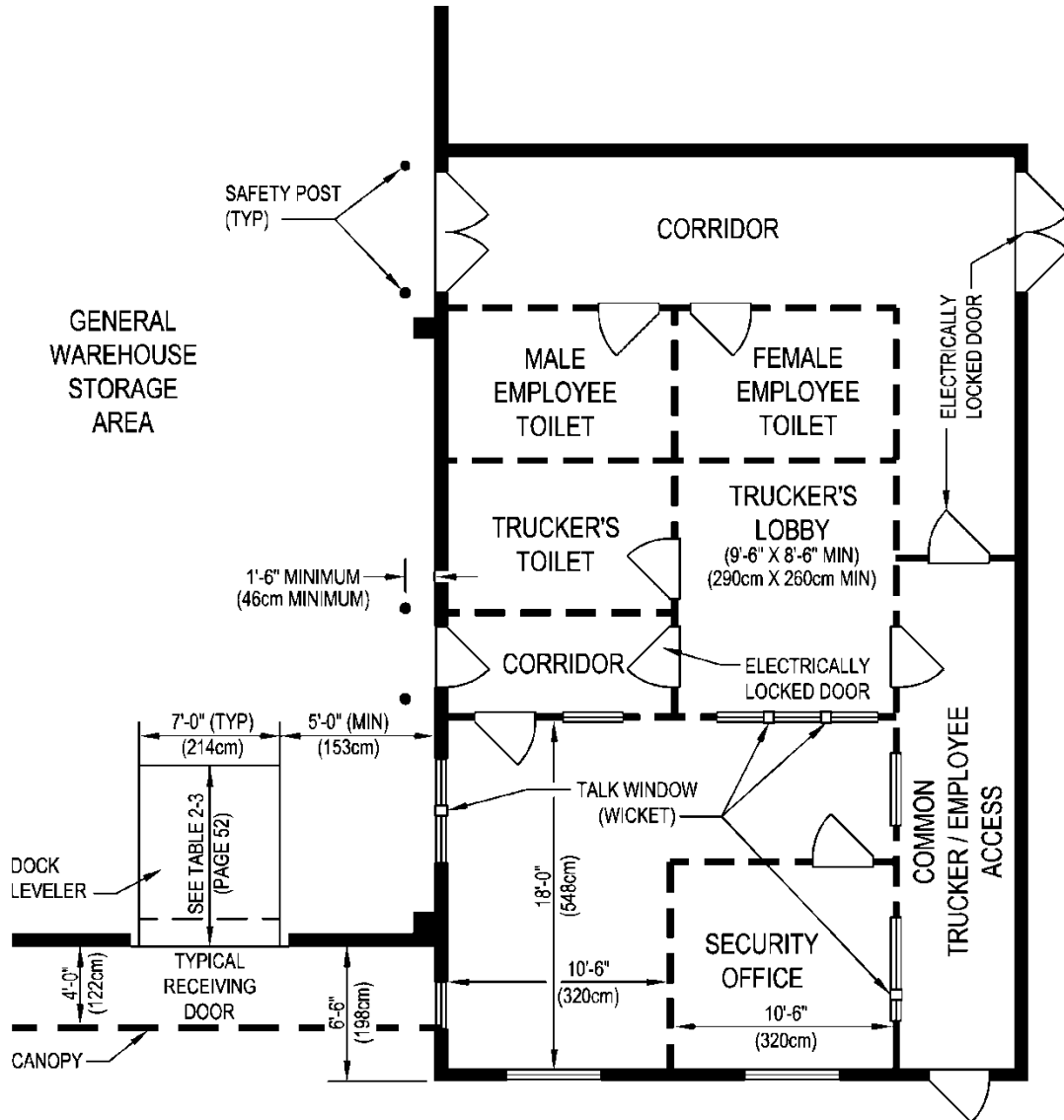

NOTE: LAYOUT SHOWN FOR ADJACENCIES AND CRITICAL DIMENSIONS ONLY

2-5.3 Shipping Office

The typical shipping office provides a separate entrance, lobby, and rest room for truck drivers. A central office area and separate rest room facilities are provided for shipping department and supervisory personnel. See figure 2-4.

Figure 2-4 Typical Shipping Office Layout - Functional Dimensions

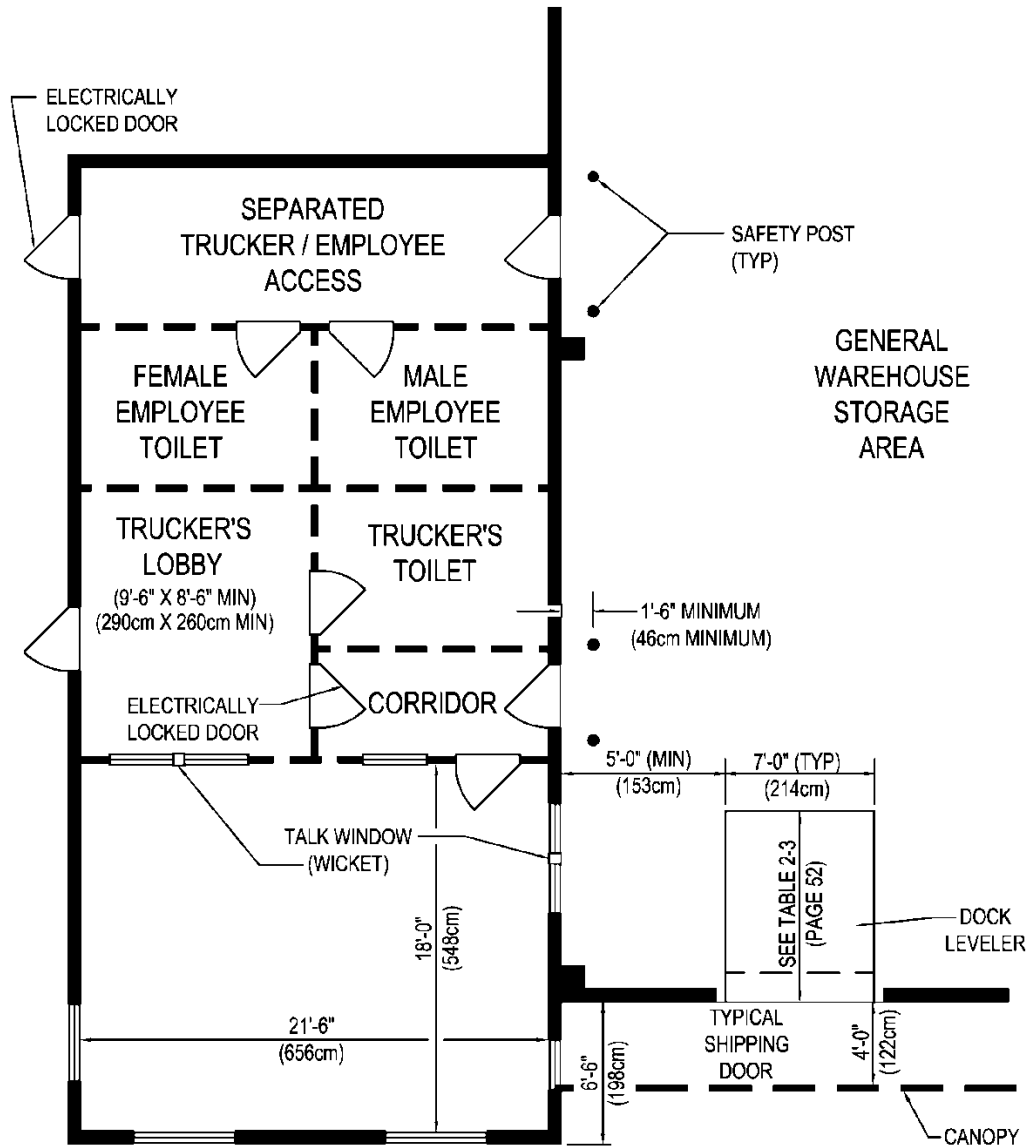

NOTE: LAYOUT SHOWN FOR ADJACENCIES AND CRITICAL DIMENSIONS ONLY

2-5.4 Rest Rooms

Separate rest room facilities may be provided for supervisory and general warehouse personnel.

2-5.5 Employee Services

Employee service areas consist of break rooms, canteen and vending machine facilities, and locker rooms. Size these areas to accommodate the expected number of employees. Multiple installations may be required to place these facilities within required distances from employee activity areas. Refer to UFC 3-101-01, *Architecture for Space Planning and Criteria* and UFC 3-420-01, *Plumbing Systems* for specific requirements.

2-5.6 Crating Operations

General purpose storage facilities may require crating of large or odd shaped items prior to storage or shipment. Variability in requirements for materials, product size, and tools necessitates individual design of crating areas. Refer to DoD 4140.1-R, *Supply Chain Material Management Regulation*, title 49 CFR *Transportation* for criteria.

2-5.7 Packing/Packaging Operations

Requirements for small item packaging may be met through use of multipurpose packing table work stations. Small item packaging must support a supply of cartons, filler material, tape, glue, labels, and scales. The design of small item packing operations must be approached on an individual facility basis.

2-5.7.1 Design

The design of small package packing station depends upon the relationship between package characteristics and throughput patterns. If the movement through the packing operation is homogeneous in terms of product characteristics and packing requirements, it is possible to install conveyor type equipment. If the packing operations must accommodate a heterogeneous mixture, a customized work station must be provided.

Refer to DoD 4140.1-R, *Supply Chain Material Management Regulation*, title 49 CFR *Transportation* for criteria. Repackaging of damaged hazardous materials packages must be performed in a designated safe area.

2-5.8 Battery Charging Area

Provide an equipped and ventilated room or area for the charging of materials handling vehicle batteries. For additional requirements see section titled "Battery Charging and Handling Operations".

2-6 PARKING

Provide parking space for facility employees. Parking areas must be separated from truck docks and other activity areas. Site security must be enforced by separating the storage facility from the remainder of the activity and further isolating parking from receiving and shipping functions. Refer to UFC 3-201-01, *Civil Engineering* for parking requirements.

2-7 TRAFFIC FLOW

Arrangement of the facility on the site and internal arrangement of the material handling systems must be evaluated to reduce or eliminate areas of conflicting traffic. Consider interaction with installation traffic flow.

2-8 SAFETY

All DoD facilities must comply with DoD Instruction 6055.1 and host services' Occupational Safety and Health Requirements. This includes but is not limited to the following:

- Provide safety markings on walls and floors in accordance with title 29 CFR 1910.22, General Requirements and title 29 CFR 1910.144, Safety Color Code for Marking Physical Hazards (Reference Figure 2-5 Typical Safety Markings). Define areas for fork-truck battery charging. Provide fire protection equipment. Provide specialized safety equipment (eye wash/shower, spill lockers, etc.) in hazardous materials areas. Provide all additional safety features required by the Occupational Safety and Health Administration (OSHA), in accordance with Title 29 Code of Federal Regulations (CFR) Part 1910, Occupational Safety and Health Standards.
- Provide exterior safety markings for fork truck refueling and vehicular operations.
- Provide all additional site safety features required by UFC 3-201-01, *Civil Engineering*.

Figure 2-5 Typical Safety Markings

Perspective Views

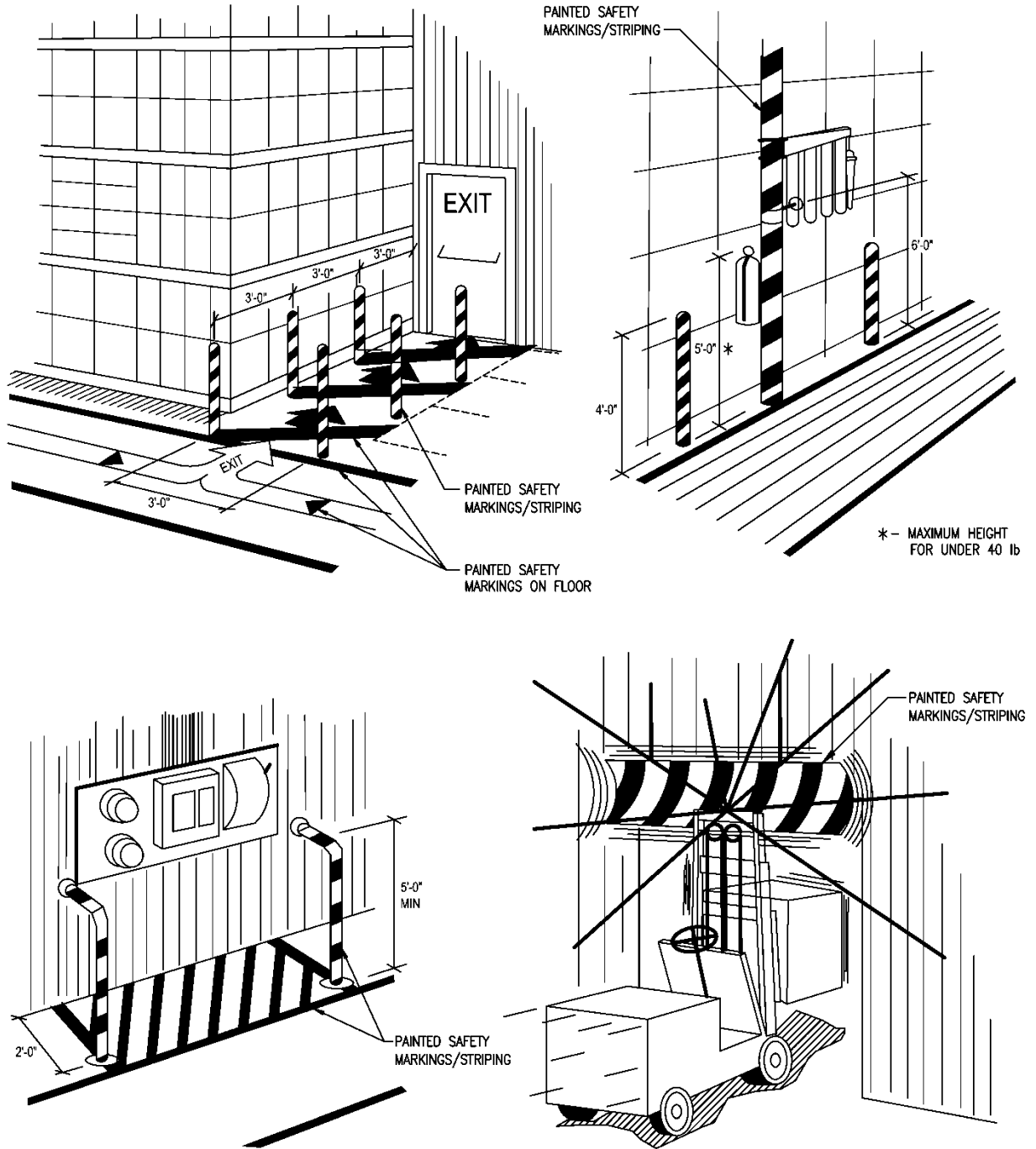

CHAPTER 3 GENERAL DESIGN CRITERIA

3-1 GENERAL DESIGN FACTORS

Providing easy and rapid materials handling and adequate clear storage space are the prime considerations in warehouse design.

3-1.1 Material Movement

Transport paths and building layout must avoid discontinuities and elevation changes which impede material movement. \1\ The transport path must be clear of structural columns or beams. /1/

Locate warehouse facilities on a site to take advantage of highway and rail facilities. Evaluate location of the facility on the site to reduce or eliminate areas of conflicting traffic.

3-1.2 Expansion Capability

Consider present and future requirements in building construction and site location to permit future expansion of facilities in an orderly, safe, and cost-efficient manner.

3-1.3 Flexible Design

Where facility usage is uncertain or subject to change, building design must use the universal bay dimension of 33 feet x 64 feet (10,060 mm x 19,510 mm).

3-1.4 Requirements of Specific Buildings

Building requirements are dictated by the function of the facility. Refer to table 3-1 for general requirements for specific types of buildings.

Table 3-1 Special Requirements for Warehouse Types

BUILDING TYPE	FUNCTIONS	SPECIAL REQUIREMENTS
General Purpose Warehouse	All-purpose structure for storing and handling supplies not requiring special considerations.	Fire protection separation between buildings; Refer to UFC 3-600-01, <i>Fire Protection Engineering for Facilities</i> , for required building separation based upon construction and exposure.
Heavy Materials Warehouse	Storing and handling heavy and bulky supplies incapable of being handled by forklift trucks, but which may be handled more economically by overhead traveling cranes.	Overhead electrical traveling cranes to handle loads too heavy or bulky to be handled by forklift trucks. Fire walls must be designed and constructed to avoid interference with operation traveling crane(s). Railroad service tracks within building. Flooring elevations at same level as top of inside railroad tracks. Door for truck entry into building and truck entrances at floor level. Ventilation: continuous ridge ventilators in unheated and non-humidified buildings only. Heating: storage areas are not heated.
Aeronautical Materials Warehouse	Storage of spare parts and component assemblies of aircraft.	Truck and rail access. High, clear storage space and large doors. Overhead traveling cranes. Heating and cooling required only for personnel comfort. Dehumidification required. Bins or storage shelves.
Hazardous Materials Warehouse	Storage and handling of hazardous chemicals and highly combustible materials.	Floor: 6 in. (150 mm) below the floor elevation of outside platforms or provide floor trenches for spill control. Flat floor with no drains or slope. Chemical resistant floor coating. Outside drainage with valve. Corrosive materials storage areas with external access doors. Ventilation: continuous mechanical from floor and roof; minimum of 1.5 air changes per hour (where all containers are sealed).
Humidity Controlled Warehouse	Preserving of stores at maximum relative humidity of 40 percent.	Proper equipment for dehumidifying. Additional electrical requirements. Measures to effectively seal openings.
Medical Warehouse	Storage of medical supplies: 1. Small auxiliary facility for hospital or dispensary. 2. Large medical supply warehouse.	Diversified functional elements include: Refrigeration, dehumidification, narcotics vaults, and heated spaces. Small facility is located and designed to best fit in local needs and support the parent structure. Large supply warehouse is a large building designed to meet present and foreseeable needs over wide areas for specified periods and situations.
Receiving, Shipping and Issue Buildings	Receiving: central point for receipt of shipments. Shipping: central point for outloading. Issue: standard storage buildings arranged for issuing supplies.	Based on the needs for receipt, unpackaging, inspecting, sorting, assembling, storage, repackaging, issue, reshipment, and other necessary handling. Special interior arrangements to carry out its mission and possibly special outloading facilities and techniques. Provisions for local issue are met by special interior layout, such as in packaging and sorting space, assembly space, inspection, bins, counters, enclosures, space for item accounting, and provisions for personnel traffic. Requirements are determined largely by the characteristics of the using agency.
Miscellaneous Facilities	Bulk Storage bins: storage of large lots of loose, solid materials. Warehouse bins: provide additional storage space in warehouse buildings.	Varying depending on the needs of the installations and materials to be contained. Materials, shape, and size determined by local needs. Arrange in double rows, back to back, and at right angles in main aisles: single rows may be arranged against walls. Passageways between open faces of bins must be a minimum of 36 in. (915 mm) wide. Metal Units: width, 36 in. (915 mm); height, 7 ft. 3 in. (2.51 m); depth, 18 in. (460 mm).
Boxing and Crating Buildings	Boxing and crating material.	One portion of building outfitted for necessary industrial operations; another portion for processing depot supplies; and the remainder devoted to storage of manufacturing stocks and assembled units.
Preservation Buildings	Special operations for preserving supplies.	Special equipment and facilities for preserving supplies before being placed in storage.
Cold Storage	Preserving stores in controlled climate ranging from -5° F (-21° C) to 50° F (10° C).	Proper equipment for cooling. Additional electrical requirements. Measures to effectively seal openings. Additional insulation requirements. Maximum utilization for storage space.

3-2 BUILDING SHAPE AND PROPORTIONS

Observe the following cautions relating to building size and shape:

3-2.1 Travel Distance

Arrange buildings or increments of buildings for minimum distance between high activity operations. Square buildings minimize perimeter wall area for a given floor area. Aspect ratios (ratio of length to width) of 1.25 or less are considered square. If possible, avoid aspect ratios exceeding 3.00 for conventional warehousing operations.

3-2.2 Irregular Shapes

Avoid irregular shapes, such as U or L.

3-2.3 Height

High-rise storage is preferred over low height buildings on a life-cycle cost basis since storage costs per unit stored, over the life of the project, decrease as height is increased. Coordinate building height parameters with storage system characteristics, as illustrated in figure 2-2.

3-2.4 Area

Limit building size based on restrictions due to loss potential and fire and hazardous chemicals safety and site restrictions. Fire protection separation between buildings; Refer to UFC 3-600-01, *Fire Protection Engineering for Facilities*, for required building separation based upon construction and exposure.

3-3 BUILDING SPACING

Required spacing between buildings to facilitate operations and aid in fire prevention, protection, and hazardous chemical spills (liquid/gas) control, will vary according to the type of construction and exposure classification. Refer to UFC 1-200-01, *General Building Requirements* and UFC 3-600-01, *Fire Protection Engineering for Facilities* for fire protection engineering requirements. Otherwise, observe the following:

3-3.1 Rail Side

Allow 120 feet (36.6 m) between faces of walls.

3-3.2 Truck Side

Allow 175 feet (53.3 m) between faces of walls.

3-3.3 Warehouses In-Line

Where a Warehouse or series of Warehouses are to be provided on a single site in a row or series of rows, in-line, allow 30 feet to 150 feet (9.1 m to 45.7 m) between faces of walls.

3-3.4 Hazardous Materials Facilities

Provide a buffer zone between the facility or portion of facility containing Hazardous Materials and the nearest inhabited area, stream, or body of water in accordance with UFC 1-200-01, *General Building Requirements* and UFC 3-600-01, *Fire Protection Engineering for Facilities*.

3-4 DOCKING FACILITIES

Provide maneuvering space to facilitate loading and unloading operations at warehouse rail and truck docks (see figure 3-1). Protect building corners and dock areas from vehicle impact by using concrete-filled steel pipes (see figure 3-2). Provide safety equipment and fall protection per OSHA and applicable codes and regulations.

Figure 3-1 Truck Apron Criteria (Functional Dimensions)

Plan View

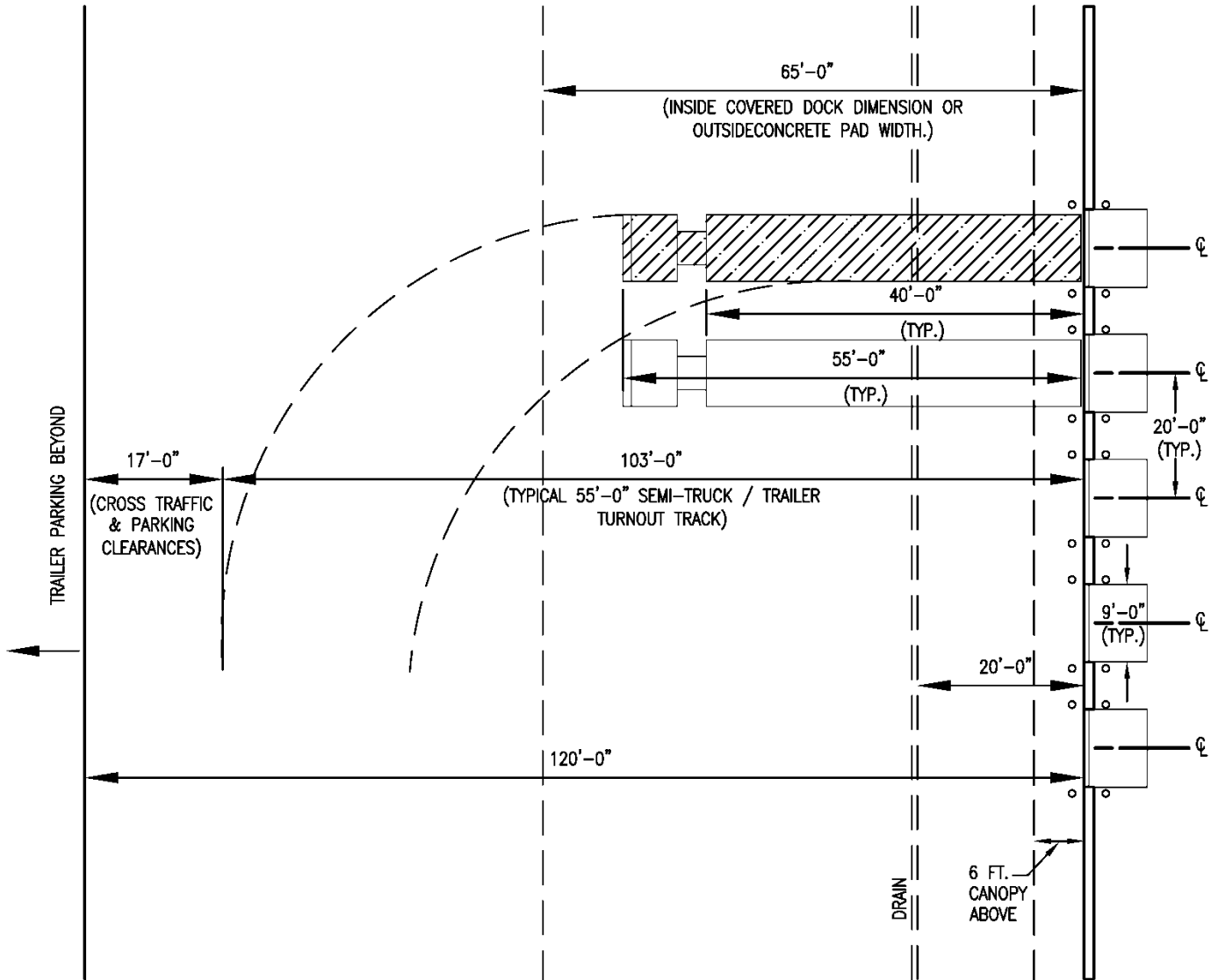
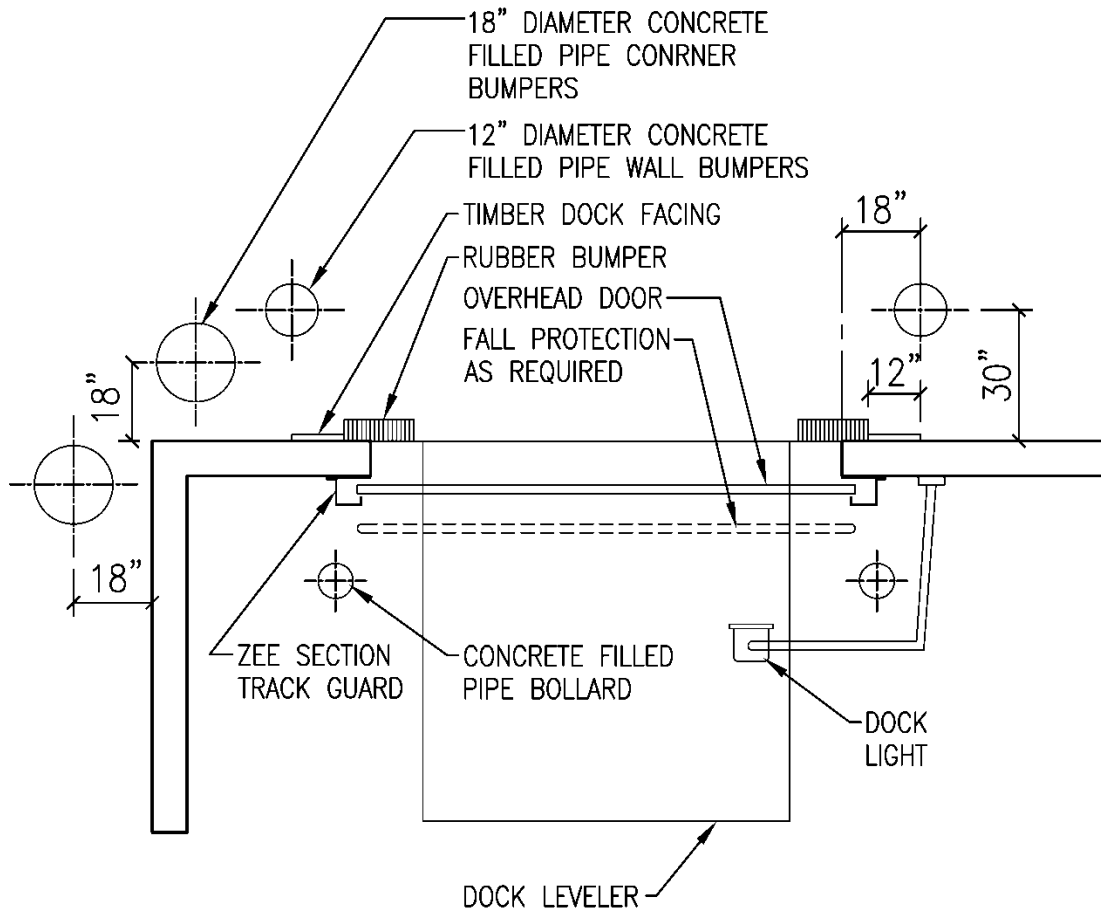

Figure 3-2 Building Protection Devices

Plan View



3-4.1 Truck Dock

Truck dock height will vary between 44 and 52 inches (1120 mm and 1320 mm) depending on the class of trucks served (see table 3-2). Use a 48-inch (1220 mm) height for general highway tractor-trailer service. Configure truck docks to conform to building, site, and traffic flow requirements (see figure 3-3). Figure 3-4 shows a typical dock section. Slope dock apron areas away from the building, as illustrated in figure 3-5. Provide doors of a size consistent with truck characteristics, as shown in figure 3-6. Open uncovered exterior truck dock platforms are not recommended. Provide space to load and unload flatbed and low-boy trucks and to move material in and out of the warehouse using a rolling A-Frame hoist or similar material handling equipment. A dock adjacent to the ramp of the building may be equipped with a 5-ton (4500 kilogram [kg]) monorail, interrupted at the door with a moveable (swing) section. A 12 x 12 foot (3660 mm x 3660 mm) door must be specified with this option. All outside supports must have protective barriers.

Table 3-2 Truck and Rail Vehicle and Dock Heights

TYPE OF TRUCK	BED HEIGHT				OVERALL HEIGHT		DOCK HEIGHT		DOCK LEVELER LENGTH (Minimum)	
	Minimum		Maximum		Minimum ft-in (mm)	Maximum ft-in (mm)	in	mm	ft	m
	In	mm	in	mm						
Container	56	1420	62	1570	12'-2" (3710)	13'-6" (4110)	52	1320	6' - 10'	1.8 - 3.0
Reefer	50	1270	60	1520	12'-6" (3810)	13'-6" (4110)	52	1320	6' - 8'	1.8 - 2.4
Flatbed (1)	48	1220	60	1520	---	---	48	1320	6' - 12'	1.8 - 3.7
Double Axle Semi (2)	46	1170	56	1420	12'-0" (3660)	13'-6" (4110)	48	1220	6' - 8'	1.8 - 2.4
Straight Semi (2)	44	1120	52	1320	12'-0" (3660)	13'-6" (4110)	48	1220	8'	2.4
City Delivery	42	1070	48	1220	11'-0" (3350)	12'-6" (3810)	48	1220	6' - 8'	1.8 - 2.4
Stake Body	42	1070	48	1220	---	---	48	1220	6' - 8'	1.8 - 2.4
High Cube Van	32	810	38	960	13'-0" (3960)	13'-6" (4110)	43	1220	8' - 12'	2.4 - 3.7
Furniture Van (3)	24	610	36	910	13'-0" (3960)	13'-6" (4110)	30	1090	8'	2.4
Step Van (3)	20	510	30	760	8'-6" (2590)	10'-0" (3050)	30	760	6' - 10'	1.8 - 3.0
Panel Truck (3)	20	510	24	610	8'-0" (2440)	9'-0" (2740)	30	760	8' - 10'	2.4 - 3.0
Low Boy (3)	20	510	24	610	---	---	30	760	8' - 10'	2.4 - 3.0
Box Car (4)	41	1040	44	1120	---	---	44	760	6'	1.8
Reefer Rail Car (4)	46	1170	52	1320	---	---	48	1120	5' - 6'	1.5 - 1.8

Notes:

- (1) Dock height range of 48"- 52" (1220-1320 mm).
- (2) Dock height of 50" (1270 mm) if serving semis only.
- (3) Dock height of 48"-50" (1220-1270 mm) recommended with exterior ramp to elevate truck to provide nominal 30" (760 mm) dock height.
- (4) Minimum dock leveler length determined by required clearance between rail car and dock.

Figure 3-3 Truck Dock Configurations

Plan Views and Section

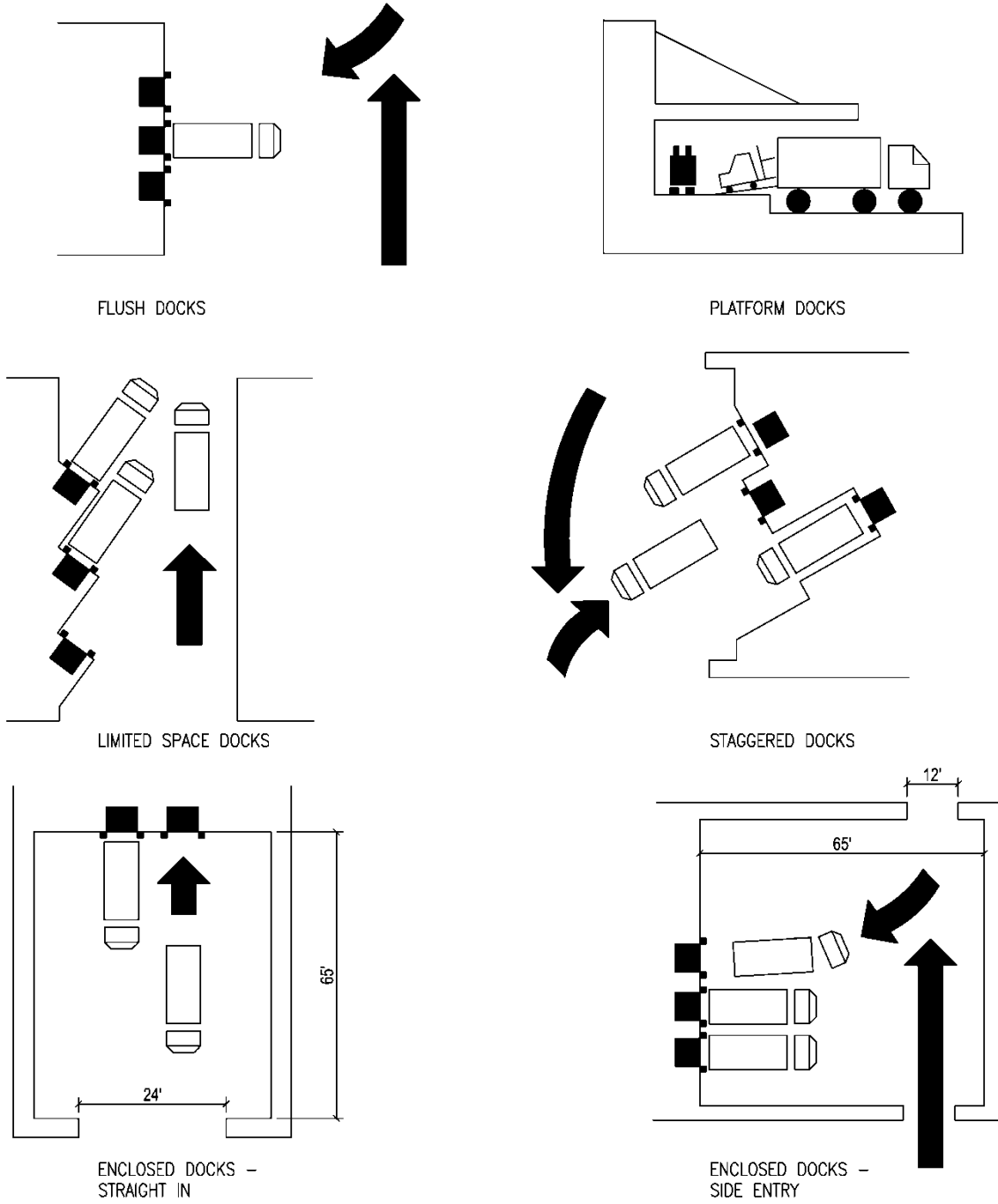

Figure 3-4 Typical Truck Dock

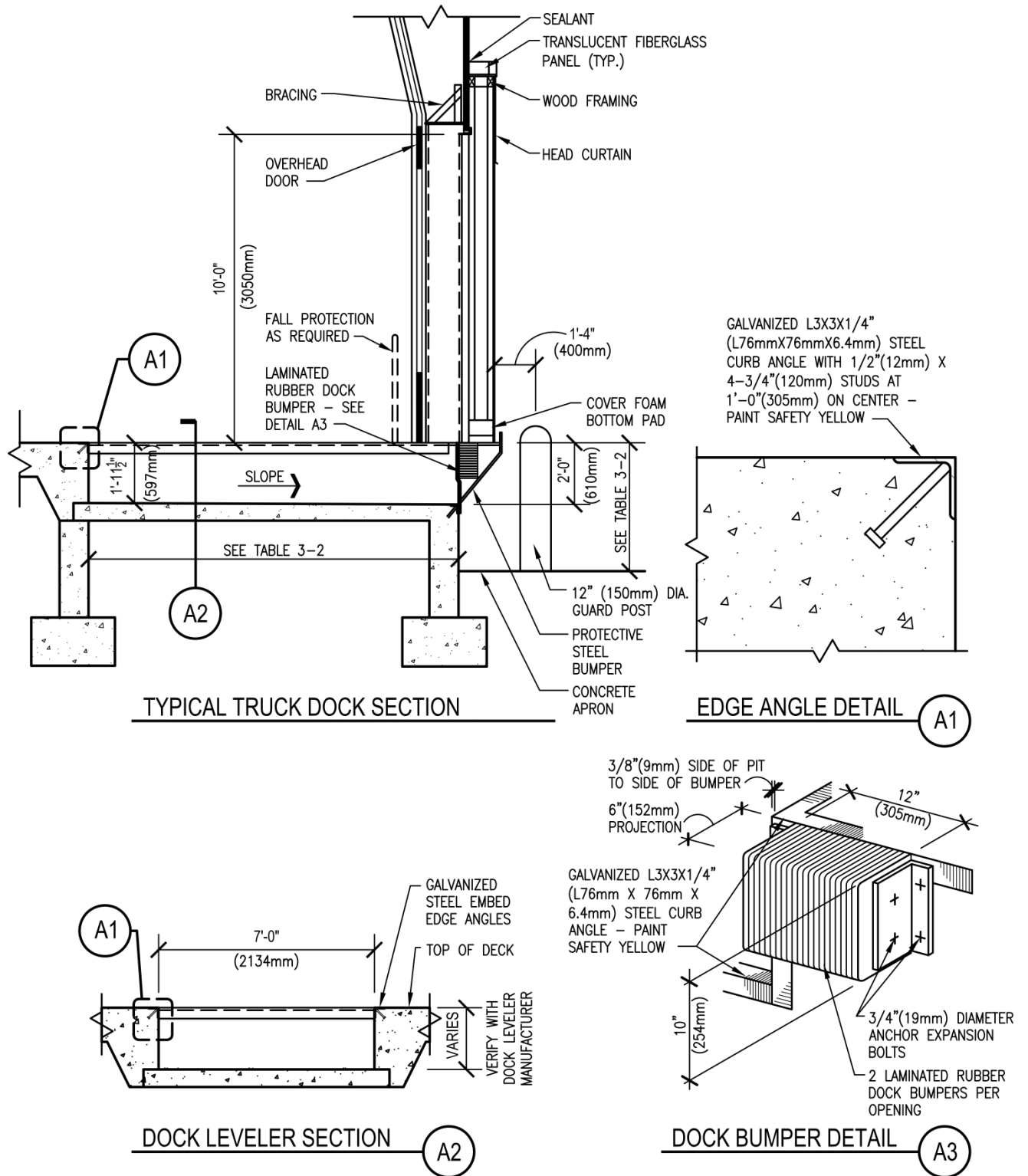
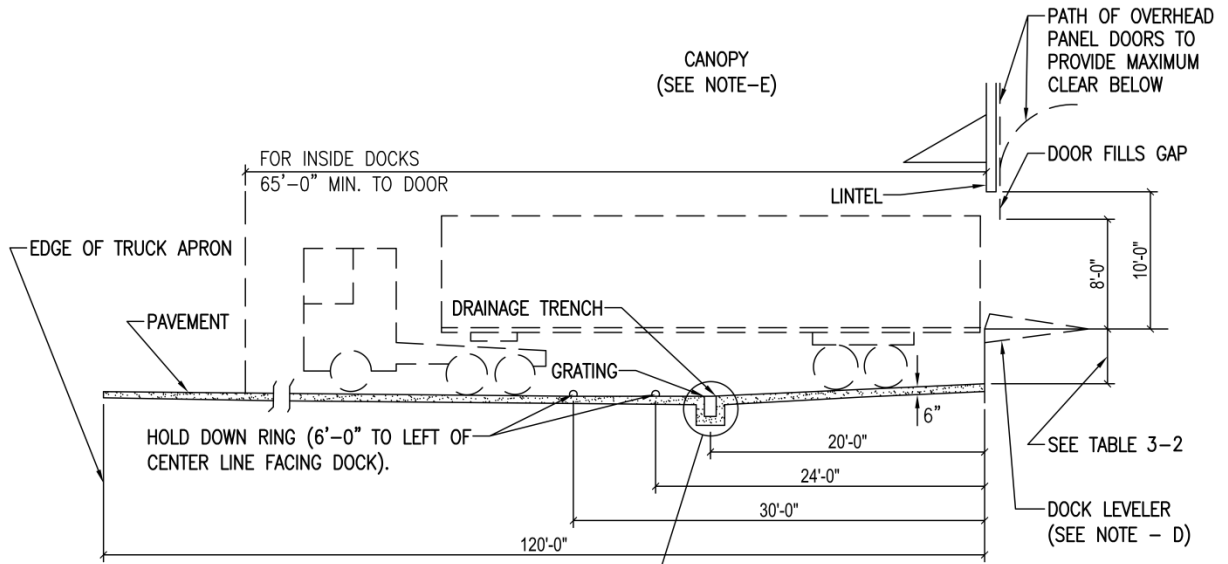

Figure 3-5 Truck Apron Section



- NOTE A: CAST IRON DRAIN PLATE AS DRAWN OR SIMILAR COMMERCIAL CASTINGS AS AVAILABLE.
- NOTE B: BAR 2x1/4x1'3" LONG ON 2'-0" CENTERS.
- NOTE C: TRENCH SLOPES 1/4" PER FOOT. PROVIDE DRAIN VALVE FOR CONTAINMENT IN HAZARDOUS/ FLAMMABLE FACILITIES.
- NOTE D: 7'-0" WIDE DOCK LEVELER WITH CROSS TRAVEL LOCK OPERATING RANGE - 12" UP 9" DOWN.
- NOTE E: CANOPY FOR OUTSIDE DOCKS. APRON FOR INSIDE DOCKS.

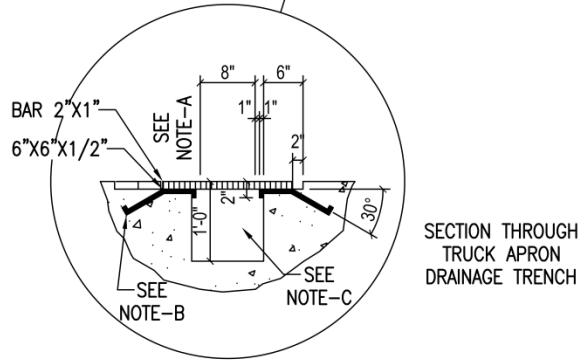
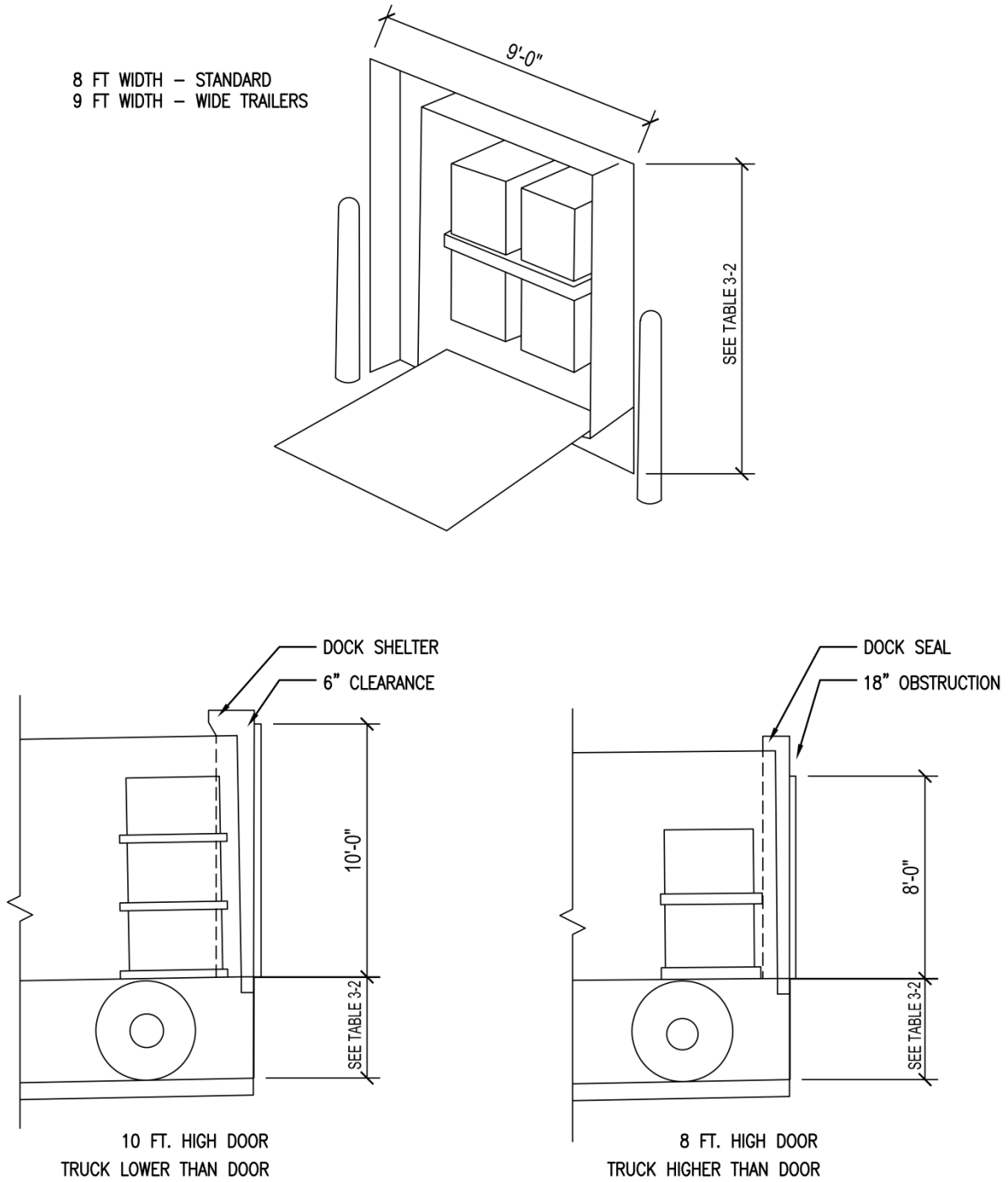

Figure 3-6 Door Size Characteristics

Perspective View and Sections



3-4.2 Rail Docks

If rail access is available include provisions for rail docks (see figure 3-7) as an option in the design of all storage facilities exceeding 40,000 square feet (3716 sq. m). There are three primary types of rail dock:

Figure 3-7 Rail Car Characteristics

Section and Elevations

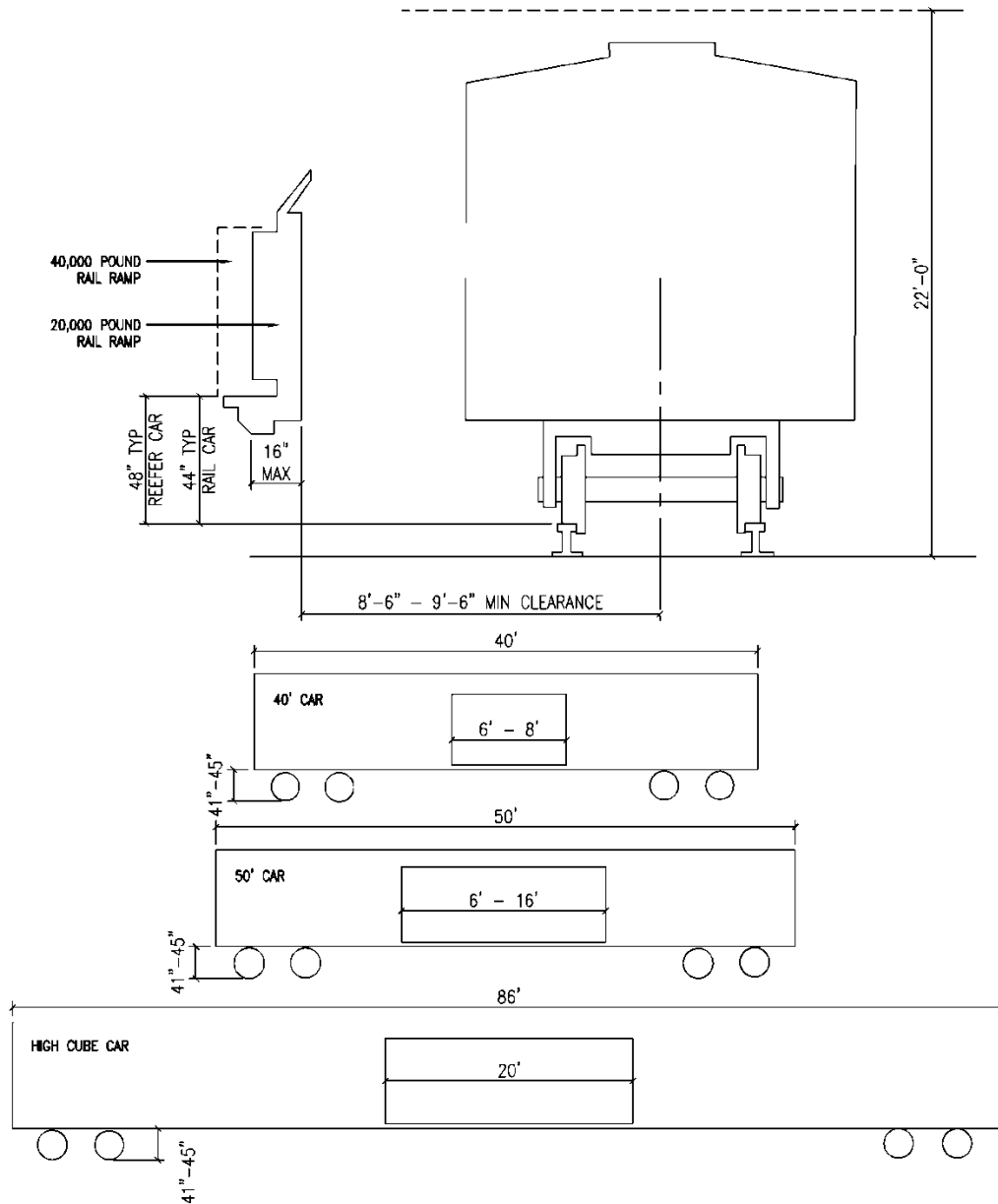

3-4.2.1 Outside Docks

Outside rail docks use through-the-wall access to rail cars without using an outside platform. Use inflatable seals to seal the space between the rail car and the warehouse. Include a wall-mounted dock board to provide access to the rail car.

3-4.2.2 Inside Docks

Inside rail docks may place the tracks inside the building in a pit constructed to place the car floor at the same level as the warehouse floor or on a floor level track. Pit type installations must include track-mounted dock boards. Because of the large amount of warehouse storage space occupied by this type of dock, inside docks are not recommended except under extreme circumstances in which sheltering of the car or additional security is required.

3-4.2.3 Platforms

Platforms for rail service must extend the full length of the building and be 15 feet (4570 mm) wide. Platform height above rails must be 3 feet 8 inches (1118 mm) for general use. Equip platforms with track-mounted dock boards. See the paragraph entitled, "Dock and Platform Weather Protection".

3-4.3 Ramp Access

Provide ramps at the end of rail platforms and at one warehouse truck dock door for vehicle access. Ramp slope must not exceed 10 percent.

For occupant accessibility requirements see the paragraph entitled, "Accessibility for the Disabled".

3-4.4 Dock Levelers

Provide dock levelers at all truck and rail dock positions. Dock leveler life is directly affected by load weight, fork truck weight, and frequency of use. Specify dock leveler capacity to provide a minimum 20 year life (see table 3-3).

Interior Dock levelers must be equipped with dock leveler seals.

Table 3-3 Dock Leveler Life (Years) Based on Impact Loading

NOMINAL RATED CAPACITY	WORKING SHIFTS	MAXIMUM GROSS LOAD (Including weight of fork truck and load)				
		5,000 lb. (2,270 kg)	10,000 lb. (4,540 kg)	15,000 lb. (6,800 kg)	20,000 lb. (9,070 kg)	25,000 lb. (11,340 kg)
20,000 lb (9,070 kg)	1	+	13	-	-	-
	2	19	7	-	-	-
	3	9	-	-	-	-
30,000 lb (13,600 kg)	1	+	+	13	-	-
	2	+	13	6	-	-
	3	18	5	-	-	-
40,000 lb (18,140 kg)	1	+	+	20	8	-
	2	+	+	9	-	-
	3	+	+	5	-	-
50,000 lb (22,680 kg)	1	+	+	+	16	11
	2	+	+	15	8	-
	3	+	18	9	-	-
60,000 lb (27,220 kg)	1	+	+	+	18	12
	2	+	+	+	8	-
	3	+	+	15	-	-

Notes:

- + Estimated life in excess of 20 years.
- Estimated life less than 5 years

3-4.5 Dock and Platform Weather Protection

Provide dock shelters or door seals in heated, air conditioned, and dehumidified warehouses, to seal the space between the truck or railcar and the building (see figure 3-8). Full width canopies must be used to shield all docks and rail service platforms from precipitation. Provide gutters and downspouts and connect to underground stormwater drainage system.

Figure 3-8 Truck Dock Weather Seals

Perspective Views

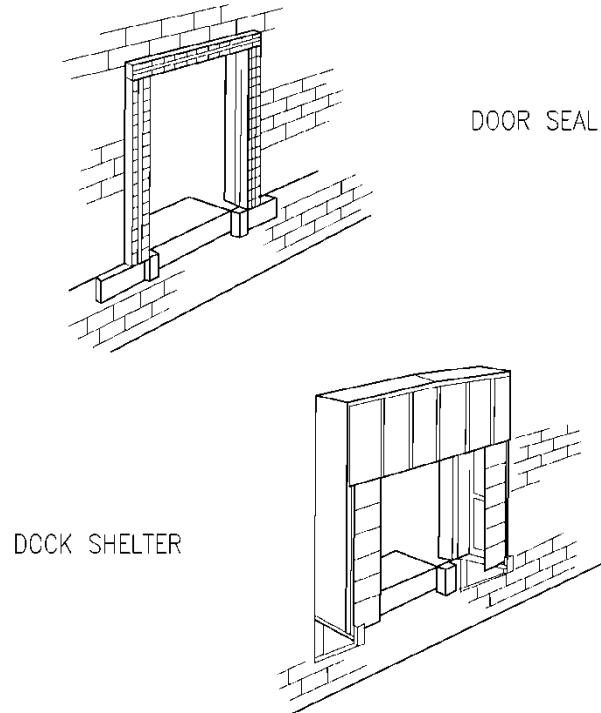

3-4.5.1 Dock Shelters

Use dock shelters in applications where truck size cannot be controlled. Sealing action is achieved through the wiping action of the shelter on the trailer when a truck backs into and through the shelter to the dock. Use shelters when the dock wall is not capable of resisting the compressive forces exerted by a door seal.

3-4.5.2 Door Seals

Door seals achieve a seal by compressing between the building wall and the trailer. Door seals provide greater sealing efficiency than dock shelters but require a structural wall capable of resisting compressive forces. Use of door seals requires close coordination of door opening size and trailer size. Excessive size incompatibility will require use of a dock shelter. Provide fire retardant door seals.

3-4.5.3 Canopy

Provide a minimum 4 foot (1830 mm) full length canopy (figure 3-9) over outside docks to protect the trailer and door interface and dock shelter or door seal from excessive weather exposure. This requirement must be evaluated with the site solar angle to alleviate solar loading in the cooling season and optimize solar gain in the heating season.

Figure 3-9 Truck Dock Canopy

Section

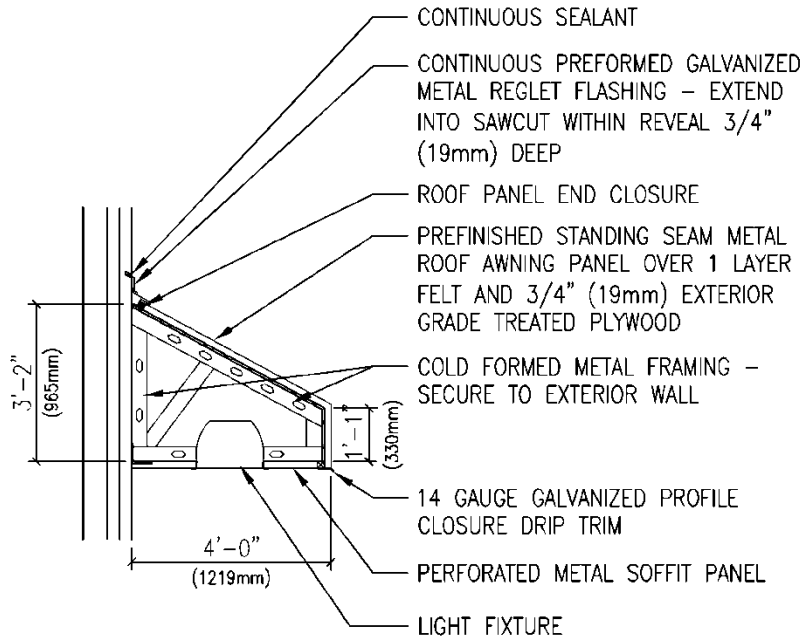

Storm drainage from canopies is prohibited to drain on grade at docks/platforms. Provide exterior downspouts connected to an underground storm water system.

3-4.6 Safety Equipment

Equip each truck dock with safety equipment consisting of wheel chocks and door-mounted lights to illuminate the trailer interior. Dock levelers must be equipped with manually or electrically operated trailer restraints with wheel chocks as a secondary safety measure. Figure 3-10 illustrates a typical installation of a dock shelter, dock leveler, and trailer restraint device.

Figure 3-10 Trailer Restraint System

Elevation View

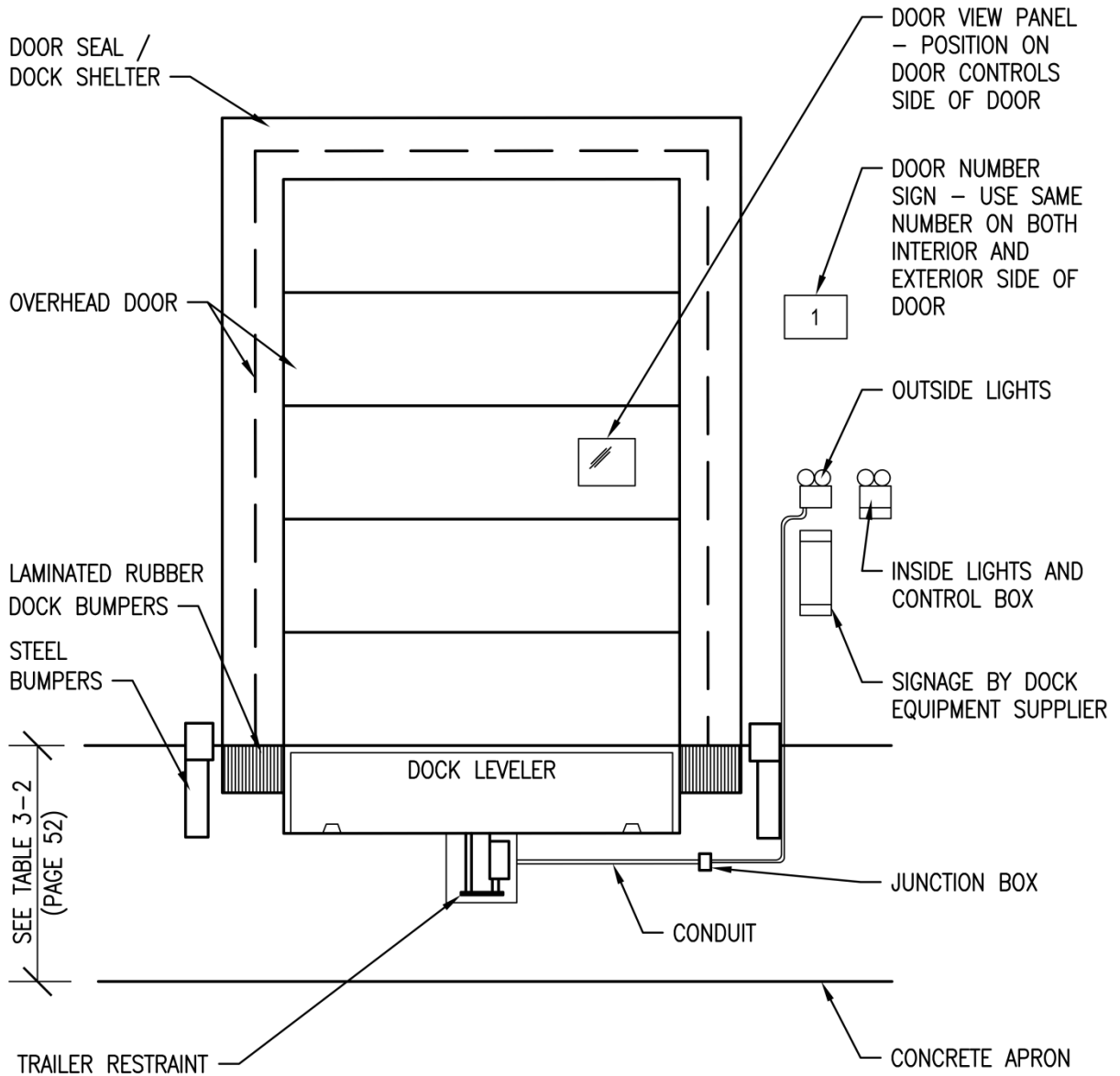

Provide fall protection per requirements of 29 CFR 1910.23, *Guarding Floor and Wall Openings and Holes.*

Provide two safety posts for each personnel door on the warehouse storage side of the door. See figure 2-3 and figure 2-4 for examples of safety posts applications.

3-5 STRUCTURAL

Refer to UFC 1-200-01, *General Building Requirements*; UFC 3-301-01, *Structural Engineering*; and UFC 3-310-04, *Seismic Design for Buildings* for structural engineering and seismic design requirements.

3-5.1 Ground Floors

Slab-on-grade systems for the offices and shop spaces of the facility must be designed in accordance with UFC 3-301-01, *Structural Engineering*. Fiber reinforced concrete systems must not be used inside the building. Slab-on-grade must have adequate thickness to support wall line loads. For slab-on-grade subject to forklift traffic, the minimum compressive strength for the concrete must be 4,000 psi (27580 kPa).

3-5.1.1 Reinforcement

Provide crack control using reinforcement consisting of minimum number 6 welded wire fabric in a 6- by 6-inch (150 mm x 150 mm) mesh or alternative non-reinforced methods.

3-5.1.2 Thickness

Floor thickness will be determined by a combination of live load, dead load, strength of concrete, and subgrade conditions. Refer to UFC 1-200-01, *General Building Requirements*, UFC 3-301-01, *Structural Engineering* and UFC 3-220-01, *Geotechnical Engineering*, for structural engineering and geotechnical engineering procedures for foundation design. Floors in warehouse facilities must be no less than 6 inches (150 mm) thick.

3-5.1.3 Static Load

Floors must be designed to support the estimated static load of stored material and storage equipment.

3-5.1.4 Impact Load

Floor design must incorporate the effects of Impact loads caused by operation of materials handling equipment. Consult equipment manufacturers for characteristics of specific vehicle impact loads

3-5.2 Superstructure

The superstructure of the warehouse must be a steel frame unless alternate structural frame systems are determined to be better suited for the facility.

The superstructure must be designed to accommodate structure supported shelving and equipment.

3-5.2.1 Structural Bracing

Structural bracing must be located so as not to impair functionality of storage areas. Exposed structural bracing must not be permitted in any administrative spaces.

3-5.2.2 Selection Factors

Determination of a structural frame system other than steel must show careful study of the advantages and disadvantages of alternative systems, as well as the reasons for using the system considered most suitable. Before selecting structural systems, determine if the building will be wall-bearing or framed construction.

Investigate the following during selection of the structural system:

- a. Availability of materials.
- b. Speed of erection.
- c. Local labor and construction practices.
- d. Quality of local materials.
- e. Limitations on materials by Department of Defense, Bureau of the Budget, or other mandatory standards.
- f. Mandatory standard drawings and specifications for certain types of buildings, such as ammunition magazines.
- g. Criteria for design of structures in typhoon, hurricane, and other high wind areas. Refer to UFC 3-301-01, *Structural Engineering*.

3-5.2.3 Conventional Construction

Conventional column/beam/truss construction or pre-engineered designs may be used for buildings up to 44 feet (13 410 mm) in height.

3-5.2.4 Rack Supported Construction

Rack supported construction, in which the storage (pallet rack) system provides the building support in the storage area, must be evaluated for all structures over 44 feet (13 410 mm) in height. For lower buildings, this method of construction must be reviewed for economic suitability.

3-5.2.5 Main Structural Framing Materials

3-5.2.5.1 Weathering Steel

Weathering steel must not be used.

3-5.2.5.2 Hollow Structural Sections

HSS members must be sealed to keep water from entering the section and animals from nesting inside. 1/4 inch (6.35 mm) diameter weep holes are allowed as necessary to release any thermal pressure built-up from within the members.

3-5.2.5.3 Exposed Structural Steel

Exposed steel shapes must be selected to minimize their surface area. All exposed steel connections must be designed to shed water. Exposed steel must be designed to permit the complete inspection of all fasteners and welds.

All exposed structural steel must be coated with a high performance coating system consisting of an epoxy primer, a high solids polyurethane intermediate coat and a high solids polyurethane top coat. Refer to UFC 3-190-06, *Protective Coatings and Paints*.

3-5.2.5.4 Corrosive Environments

Refer to UFC 3-301-01, *Structural Engineering* for requirements of steel structures in corrosive environments.

3-5.2.6 Secondary Structural System

The walls and partitions of the warehouse must be non-load bearing and must not be considered as elements of the lateral load resisting system. The walls of the office and shop portion(s) of the facility may be designed as load bearing if structurally isolated from the warehouse structure.

3-5.2.7 Strength and serviceability requirements

In addition to the loads described in or incorporated by reference by UFC 1-200-01, *General Building Requirements*, the design must account for all loads imposed by bridge cranes or other specialty equipment supported by the structure. Cold-Formed steel framing systems must be designed for vibration serviceability.

The structural frame must be designed to accommodate 125% of the loading from overhead bridge cranes. The designer must consider the effect of pattern loads resulting from multiple loaded hooks. All crane hardware and lifted loads must be treated as live loads in the load combinations defined in chapter 16 of the IBC, except for patented tracks, tracks, supports, sway braces and similar elements which are immobile and may be defined as dead loads.

3-5.2.7.1 Gravity loads

In determining design load combinations for structures in which the dead load of one portion of the building serves as stability enhancing function for another portion of the building (i.e. Cantilevered construction), the following cases must be considered in addition to the basic load cases.

3-5.2.7.2 Factored Load Combinations

If the dead load of any portion of the facility, including a structurally isolated administration and shop structure sharing a common foundation, is used to resist uplift forces, it must be factored by 0.9 in strength design analysis and by 0.6 in stress design analysis if it favorably contributes to the performance of the system.

3-5.2.7.3 Wind and Snow Loads

Refer to UFC 3-301-01, *Structural Engineering*.

3-5.2.7.4 Seismic Loads

Refer to UFC 1-200-01, *General Building Requirements*; UFC 3-301-01, *Structural Engineering*; and UFC 3-310-04, *Seismic Design for Buildings*, for structural engineering and seismic design requirements.

3-5.2.7.5 Thermal Loads

In addition to the thermal loads of the IBC, the designer must account for anticipated differential thermal effects from solar heating (e.g., on long sun-exposed exterior steel compared to shaded steel such as roof trusses, joists or decking) or inside/outside differences (particularly a “stratification” effect in the warehouse storage bay). Consider the local climate conditions when selecting the final differential temperature range, as a minimum, a temperature differential of 50°F (28°C) must be used for design. The deflections caused by differential thermal effects must be investigated by the engineer of record. Some architectural fascia elements and weather seals around large overhead doors are particularly vulnerable to detrimental deflections. The differential thermal effects are a serviceability concern and must be investigated using unfactored loads.

The design must also control deflections to within the limits imposed by section 1604 of the IBC in compliance with UFC 3-301-01, *Structural Engineering* unless stricter control is necessary to support equipment, fascia or other appurtenances. The warehouse roof must meet the requirements of a structure “supporting a non-plaster ceiling” and the walls must meet the requirements of a “partition with flexible finishes.” The administrative area must meet the deflection requirements appropriate to finish type. If the warehouse and administrative area framing is constructed as a single frame, the combined structure must meet the most stringent requirements described above.

3-5.2.7.6 Deflection and Drift

The deflection of structural elements, evaluated under service level loads, must provide for the serviceability of the structure and all of its components, including but not limited to exterior walls and cladding, partition walls, hangar doors, bridge cranes, utilities and other appurtenances. However, in no instance must the deflection of any structural element exceed the limits of the IBC. The lateral drift (sideways) of the structure as a whole, evaluated under service level loads, must provide for the serviceability of the structure and all of its components, including but not limited to exterior walls and

cladding, partition walls, overhead doors, bridge cranes, utilities and other appurtenances. However, in no instance must the drift of the structure exceed the mean roof height divided by 320. If the structure has multiple roof elevations, this requirement must be independently met at each roof level.

3-6 EXTERIOR DESIGN

Exterior walls of the warehouse must be of a construction suitable to the building type, be compatible with the design of the existing building / adjacent buildings with regards to building form, height, materials selection, color and architectural detailing and be protected from abuse, both interior and exterior. Exterior walls and building signage must be compatible with the Installation Appearance Plan (IAP) or other written documents. For Design/Build projects, coordinate any specific requirements for materials prior to issuing the RFP.

Exterior design and architecture must comply with UFC 1-200-01, *General Building Requirements*, UFC 3-101-01, *Architecture* and UFC 1-200-02, *High Performance and Sustainable Building Requirements*.

3-6.1 Surface Treatment

The chemical properties of materials and finishes for exterior surfaces must have the highest possible resistance to the effects of weather and salt-corrosive atmosphere.

Where metal panels are used for exterior wall and roof surfaces, provide a factory applied finish system to resist corrosive climatic effects.

3-6.2 Roofing Systems

Low-slope roofs must be used to minimize potentially unusable space caused by the roof rise associated with sloped roofs. Sloped roofs having a pitch exceeding 1 inch per foot (83 mm per meter) must be avoided for warehouse facilities unless available roofing materials require a greater pitch. When the roof slope exceeds 2 inch per foot (166 mm per meter) the sprinkler operating area and sequence will be impacted. Sheds may have a roof pitch of 2 inches per foot (166 mm per meter) or greater.

Refer to UFC 1-200-01, *General Building Requirements* and UFC 3-110-03, *Roofing*.

The following criteria apply:

- a. Combustible roofing is permitted only in emergency construction.
- b. Roofing construction may consist of steel decking, reinforced concrete, or precast concrete panels.
- c. Gutters and downspouts must be used. Positive measures must be taken to prevent accumulations of mud, snow, or ice. Where downspouts are to

outlet on-grade splash blocks of adequate size for downspout capacity must be provided.

- d. Refer to UFC 3-110-03, *Roofing*, for standards concerning materials and installation for built-up roofing.
- e. Provide a drop ceiling in the warehouse when the roof slope is greater than 2 inch per foot (166 mm per meter).

3-6.2.1 Low-Slope

Low-slope roofs must have a minimum pitch of 1/2 inch per foot (42 mm per meter).

3-6.2.2 Steep Slope

Sloped roofs having a pitch of 3-4 inches per foot (250-333 mm per meter) may be used in small spans where roof rise can be limited to 5 feet (1525 mm) or less.

3-6.3 Exterior Walls

Exterior walls may be of insulated metal siding, brick or concrete masonry, or tilt up precast or cast-in-place concrete panels. When metal walls are used, the first 4 feet (1220 mm) of wall above the floor must be of reinforced masonry construction to protect the structure from fork truck impact and provide additional security. Walls located on sides designated for future expansion must be removable.

3-6.4 Dock Doors

Size dock doors consistent with the types of delivery vehicles expected to operate around the facility.

See table 3-4 for recommended door sizes.

Table 3-4 Recommended Door and Portal Sizes

Description	Width		Height	
	inches	mm	inches	mm
Standard Truck Door	9'-0"	2,743.2 mm	10'-0"	3,048.0 mm
Air Lines of Communication (ALOC) Door	10'-0"	2,743.2 mm	10'-0"	3,048.0 mm
Transporter Door	10'-0"	3,048.0 mm	10'-0"	3,048.0 mm
Firewall Door (interior between bays)	15'-0"	4,572.0 mm	15'-0"	4,572.0 mm
Oversized Door	12'-0"	3,657.6 mm	10'-0"	3,048.0 mm
Forklift Ramp Door	15'-0"	4,572.0 mm	15'-0"	4,572.0 mm
Truck Well Door	12'-0"	3,657.6 mm	15'-0"	4,572.0 mm

3-6.4.1 Dock Door Height

Truck dock doors must be at least 9 feet (2745 mm) high.

3-6.4.2 Dock Door Width

Truck dock doors must be at least 9 feet (2745 mm) wide.

3-6.4.3 Dock Door Safety Hardware

Provide safety hardware meeting the requirements of UL 325, *Door, Drapery, Gate, Louver, and Window Operators and Systems* and ANSI B11.19, *Performance Requirements for Safeguarding*.

3-6.5 Fire Doors

In heater rooms and transformer vaults, doors must be metal-covered or industrial-type metal fire doors, as required. \1V1/Refer to UFC 3-600-01, *Fire Protection Engineering for Facilities*.

3-6.6 Windows

All fenestration must conform to the recommendations of the Threat / Vulnerability Assessment and Risk Analysis. Place windows to prevent illicit entry accomplished by reaching adjacent entry door hardware.

Use windows meeting American Architectural Manufacturers Association (AAMA) type HC60 window specifications (AAMA WSG-11, *Window Selection Guide*). Windows must be thermally broken pre-finished aluminum with tinted, low-e glass. Use laminated glazing and comply with UFC 4-010-01, *DoD Minimum Antiterrorism Standards for Buildings* in portions of the building that qualify as “inhabited”, including “inside” windows exposed by the warehouse bay. Both panes must have laminated glazing. Specify commercial grade windows with heavy-duty insect screen for operating section. Solar glazing with low “e” glass is required in regions with plentiful sunlight.

3-6.7 Doors and Hardware

Exterior doors with closers must be Level 4, physical performance Level A doors complying with ANSI/SDI A250.8, *Standard Steel Doors and Frames*. Frames must match door level. Exterior door frames must be welded type.

Provide Grade 1 hardware typical. Locksets must be mortise type, Series 1000 as defined by ANSI/BHMA - A156.13, *Mortise Locks and Latches* for shop and maintenance level doors. Hinges for doors with closers must be full mortise butt hinges except where special types are required. Closers must be the best and highest grade available from each manufacturer. Exterior doors must have overhead rain drips and door drips.

3-6.8 Signage

Provide exterior signage in accordance with UFC 3-120-01, *Design: Sign Standards*.

3-7 INTERIOR DESIGN

Durability is extremely important when specifying materials for interior construction and finishes. Warehouses regularly handle heavy equipment throughout the facility. All finishes and components must be selected based on the operations performed in the warehouse, and shop spaces. These conditions will lead to greater interior damage being incurred compared to many other facility types.

Refer to UFC 1-200-01, *General Building Requirements* and UFC 3-120-10, *Interior Design*.

3-7.1 Interior Walls

Interior wall construction will vary depending upon use, finish, and required fire and corrosion resistance. Refer to UFC 1-200-01, *General Building Requirements*.

3-7.2 Doors and Windows

Windows must be provided for office and service structures when located on an exterior wall. A continuous narrow band of high windows may be justified in large warehouses by savings in electric lighting costs as determined by energy modeling.

3-7.2.1 Doors

Provide interior door openings and portals of sufficient height and width to permit passage of materials handling equipment. Size doors and portals consistent with the types of trucks expected to operate in the facility. These requirements do not apply to personnel type exit doors.

See table 3-4 for standard door and portal sizes.

3-7.2.1.1 Door Height

Doors must provide a minimum of 6 inches (150 mm) clearance for the highest loads or vehicles expected to operate in the facility.

3-7.2.1.2 Door Width

Doors must provide a minimum of 12 inches (300 mm) clearance on each side of passing materials handling equipment.

3-7.2.1.3 Hardware

Provide Grade 1 hardware typical. Locksets must be mortise type, Series 1000 as defined by ANSI/BHMA - A156.13, *Mortise Locks and Latches*. Locksets for administrative spaces may be Series 4000 as defined by ANSI/BHMA - A156.2, *Bored and Preassembled Locks and Latches*. Hinges for doors with closers must be full mortise butt hinges.

Metal overhead doors must be chain hoist operated, except when frequent use demands motorized operation.

3-7.3 Signage

Provide safety markings on walls and floors (figure 2-5.) Refer to Title 29 Code of Federal Regulations (CFR) Part 1910, *Occupational Safety and Health Standards*.

Provide interior signage in accordance with the requirements of UFC 3-120-01, *Design: Sign Standards*.

3-7.3.1 Identification

Provide identification signage to inform personnel of area identification, function, services, safety, and storage locations.

3-7.3.2 Warning

Identify all hazards, hazardous equipment, and restricted areas with suitable warning signage.

3-7.4 Warehouse Storage Area

The warehouse must be provided with durable finishes. The exterior walls must have as a minimum, a protective panel along the exterior walls that will prevent damage to the exterior finish system. The minimum protection can be provided by a metal panel attached to the wall panel girts. The protective panel must extend to at least 7 feet (2.13 meters) above the warehouse floor. Alternatively, masonry may be provided.

3-7.4.1 Floors

Critical attention to floor design and construction is essential to proper operation of narrow aisle high-rise storage systems. Provide a Class 5 floor in accordance with American Concrete Institute (ACI) *Guide for Concrete Floor Slab Construction*, AC1 302.1R-04 and UFC 1-200-01, *General Building Requirements*, for areas not otherwise specified.

3-7.4.1.1 Finishes

Floor hardeners, dressings, or toppings are required for durability in areas of exceptionally high activity such as main aisles, topline paths, or industrial shop areas. Sealers are required for dust control.

3-7.4.2 Superflat Floors

High rise, narrow aisle storage systems with aisles less than 96 Inches (2440 mm) wide and storage heights exceeding 20 feet (6100 mm) require extremely smooth and flat floors to control operating tolerances. Superflat floors must be designed and specified for vehicles such as turret trucks and man-up order picking trucks. Provide superflat, class 9 floors in accordance with ACI 302.1R-04, *Guide for Concrete Floor and Slab Construction*.

3-7.4.2.1 Construction Guidelines

In order to assure that superflat tolerances can be achieved, the following design and construction guidelines must be followed:

- a. Clearly identify on the design drawings those areas of the warehouse floor which must meet superflat tolerances.
- b. Incorporate a requirement in the construction contract for test slabs to assure that the superflat floor tolerances can be achieved with the contractor's proposed operations.
- c. All longitudinal construction joints must be located outside of the aisles in which the trucks operate. Space transverse weakened plane joints to control random cracking and potential slab warping. A transverse joint spacing of 20 feet (6100 mm) will generally be satisfactory. Transverse joints must be sawed and sealed.
- d. Locate floor drains, cleanouts, conduits, and other floor discontinuities outside of the aisles and where appropriate to allow for access by maintenance personnel to perform routine maintenance.
- e. Specify a concrete mix having a low water-cement ratio and low shrinkage characteristics. Achieve concrete workability through use of plasticizers in lieu of additional water.
- f. During construction, pour concrete between rigid forms in lanes less than 20 feet (6100 mm) wide. Strike off concrete with a vibrating screed.
- g. After initial floating, use a 10 foot (3050 mm) long transverse scraping straightedge (highway straightedge) to remove high spots.
- h. Check the surface of the plastic concrete frequently with a 10 foot (3050 mm) long straightedge placed both parallel and transverse to the

centerline. Correct any high spots and fill any low spots using the highway straightedge.

- i. Use of a boom operated laser leveling screed is greatly encouraged to achieve superflat floor tolerances.

3-7.4.2.2 Measurement

Refer to ACI 302.1R-04, *Guide for Concrete Floor and Slab Construction* for measurement requirements for class 9 superflat floors and the following requirements:

- a. In specifying floor flatness for turret truck and order-picking truck operations, require a complete (100%) profile analysis of the wheel path portion of the concrete floor in the storage aisles and a statistical profile analysis of other portions of the concrete floor on which turret trucks and order-picking trucks will operate.
- b. For measurement of floor flatness, require use of special floor flatness profile measurement equipment such as the "Profilograph" or an equivalent measuring equipment technique. Measurements must be taken at 20 ft. (6 m) intervals in each of two perpendicular directions.
- c. Require in the specifications that the general contractor provide certification to be prepared by the measuring equipment operator. Certification states that the "wheel path" and other portions of the concrete floor to be used for turret truck and order-picking truck operations must completely meet maximum rated productivity floor flatness requirements of the Headquarters Office of the truck manufacturer(s). Floors which fail to meet the required tolerances will be corrected as directed by the Contracting Officer.
- d. All noncritical floor slabs must be specified to be an ACI Class Bx floor. See ACI 302.1 R-04, *Guide for Concrete Floor and Slab Construction* for Class Bx criteria.

3-7.4.3 Wire Guide Requirements

When electronic wire guide vehicle controls are used, observe the following floor design criteria:

3-7.4.3.1 Conduits

Avoid installing conduits in the floor.

3-7.4.3.2 Reinforcing

Reinforcing steel must be located at least 2 inches (50 mm) below the concrete surface. Wire mesh must be tack-welded together wherever possible. Rebar and wire mesh must be grounded.

3-7.4.3.3 Expansion Joints

Where possible, expansion joints must not be located under storage racks. When expansion joints are located in the storage aisle, they must run parallel to the aisle and not be within 3 inches (75 mm) of the centerline of the storage aisle or within materials handling equipment wheel tracks. Expansion joint material used in hazardous materials storage areas must be compatible with the contents of the materials being stored.

3-7.4.4 Walls

All unfinished items must be painted.

Paint wall surfaces a light color(s) to reduce lighting demands.

3-7.4.5 Ceilings

Paint all structural steel, deck and other non-prefinished items.

3-7.5 Shops and Storage Rooms

3-7.5.1 Walls and Partitions

Walls must be painted concrete masonry units or concrete around shop spaces. Partitions separating shops may be impact resistant gypsum wall board on metal studs. For shops without ceilings, partitions must extend to structure above.

3-7.5.2 Floors

Floor finish must be an epoxy floor coating compliant with Master Painter's Institute - MPI 212, *Floor Coating, Thin Film, for Aircraft Maintenance Facilities* or sealed concrete.

3-7.5.3 Ceilings

Shops must not have suspended ceilings. All exposed piping, structure, deck, ductwork, etc. must be painted.

3-7.6 Administration and Office Spaces

3-7.6.1 Partitions

Partitions separating administration spaces from the warehouse space must be concrete masonry construction. Partitions separating administrative spaces may be gypsum board construction. Partitions are not required to extend to above the ceiling for similar office types and spaces where noise between offices is not an acoustical issue or required for personnel counseling. Paint all unfinished materials.

3-7.6.2 Floors

Floor finishes must be standard type finishes based on the expected usage of the spaces. Provide a wall base in all spaces.

3-7.6.3 Ceilings

Provide suspended acoustical ceilings in all administrative spaces.

3-7.7 Toilet and Locker Rooms

3-7.7.1 Partitions

Provide CMU partitions around toilet and locker rooms. Partitions around perimeter of space must extend to floor or roof construction above. Provide ceramic tile wainscot and ceramic base. Provide ceramic tile wall finishes to the ceiling on all walls in showers.

3-7.7.2 Floors

Floor finishes must be ceramic tile.

3-7.7.3 Ceilings

Ceilings in toilets must be gypsum wall board. Ceilings in locker rooms must be suspended acoustical ceilings with a water resistant membrane. Ceilings in showers must be water resistant gypsum board. Plaster is not allowed.

3-7.7.4 Lockers

Provide personnel lockers in dedicated locker rooms. The number of personnel lockers must be identified in the RFP. Lockers are provided for personnel to keep personal items or clothing during their work shift. Provide lockers with solid sides and louvered doors.

Lockers must be 9" x 21" x 72" (229mm x 533mm x 1829mm) high and must be single tier type. All lockers must be metal and must have capability to receive padlocks.

3-7.8 Corridors and Stairs

3-7.8.1 Partitions

Partitions in corridors and stairs must be painted masonry or painted gypsum board. Gypsum board must be impact resistant type to 8 feet (2.44 meters) above the floor or stair level. Corridor partitions and rooms without ceilings must extend to the deck above.

3-7.8.2 Floors

Floor finishes for these spaces must be as determined by the designer but minimum finish must be a resilient flooring system.

3-7.8.3 Ceilings

Corridors must have suspended acoustical ceilings, typical.

3-7.9 Support Spaces

Support spaces such as mechanical, pump rooms, and electrical rooms must be provided as required. These spaces must be as determined by the requirements of the project.

Partitions in corridors, around mechanical, electrical, and similar type spaces must be painted masonry. Corridor partitions and rooms without ceilings must extend to the deck above. All exposed piping, structure, deck, ductwork, etc. must be painted.

3-7.10 Battery Charging and Handling Operations

Provide an equipped and ventilated area for the charging of materials handling vehicle batteries. Figures 3-11, 3-12 and 3-13 illustrate typical battery charging layouts. Hydrogen detectors must be provided at Battery Charging Areas.

Figure 3-11 Battery Charging Area (Open Locations)

Plan Views

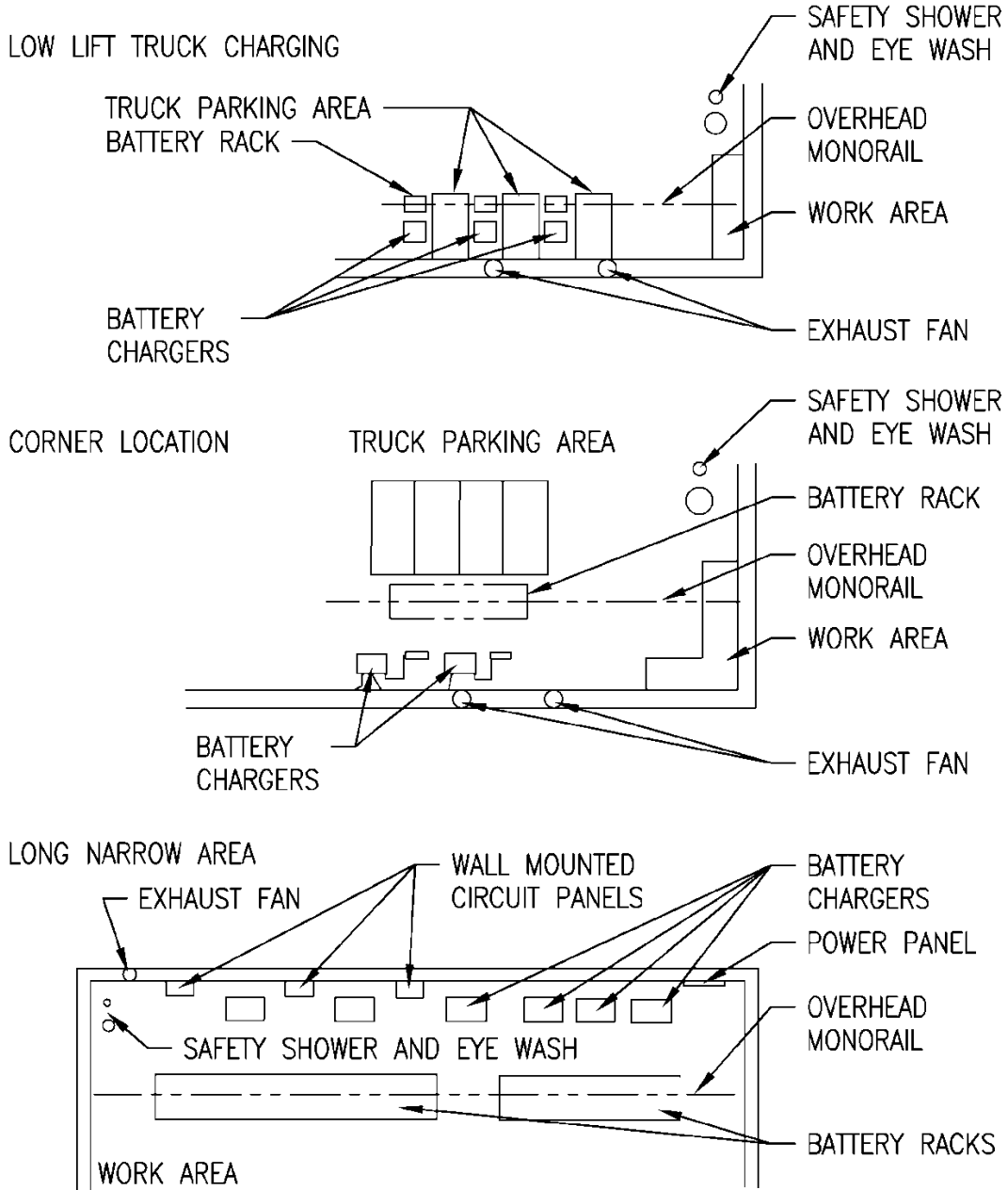
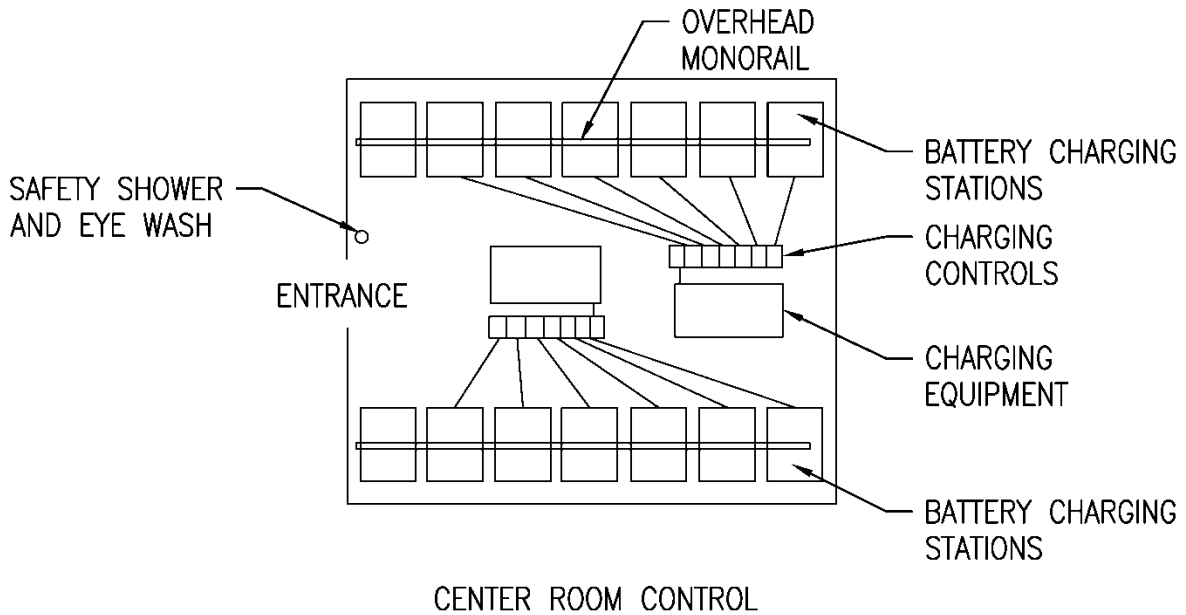
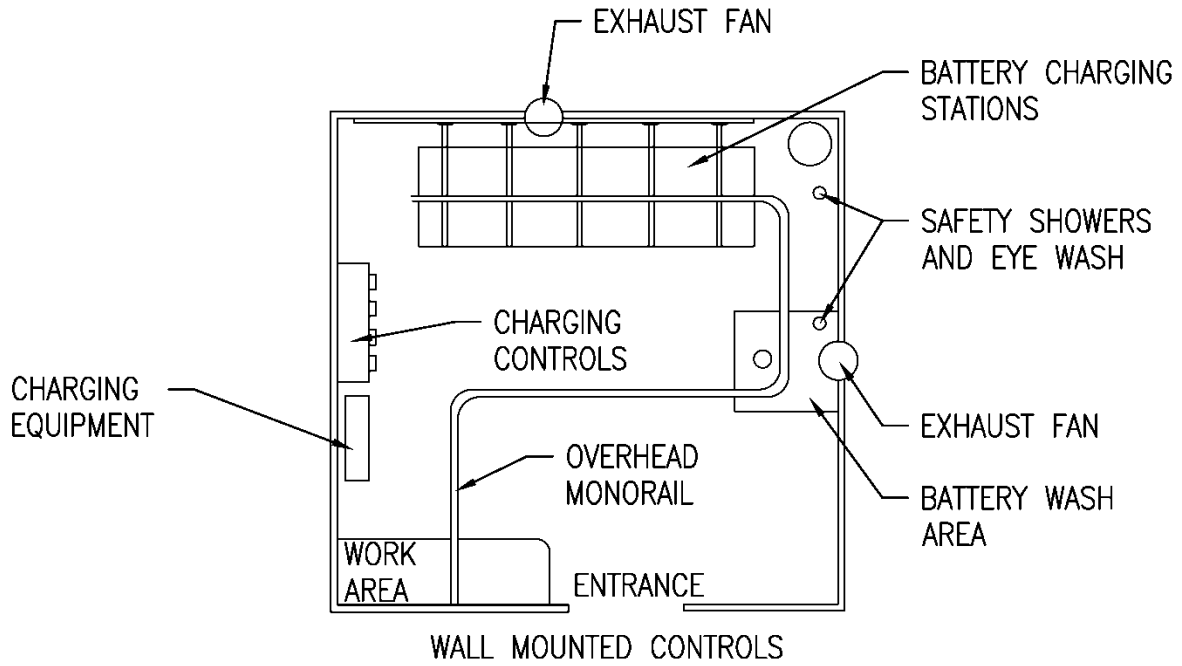

Figure 3-12 Battery Charging Area (One-Entrance Room)

Plan Views



3-7.10.1 Containment Pit

Contact the local environmental office for regulations about handling contaminated water.

Provide a spill containment pit with a floor grate to capture water and contaminants from the safety shower/eyewash and accidental battery discharge. The pit must be equipped with a shut off valve to allow for proper neutralization of contaminated water before discharging. The pit must be large enough to hold the entire contents of the largest battery serviced in the area as well as all the water from a 15 minute shower.

3-7.10.2 Safety Showers / Spill Control

Provide facilities for the emergency drenching of the eyes and body, flushing and neutralizing spilled electrolyte, and protecting charging apparatus from damage (figure 3-13) in accordance with UFC 3-420-01, *Plumbing Systems*. Battery charging areas must be equipped with neutralizing chemicals. Floors must be treated with an acid resistant coating. Install permanent eyewash and shower facilities wherever permanent charging or servicing areas are constructed.

Figure 3-13 Typical Battery Charger Installation
(With Eye Wash/Shower using Standard Pallet Rack)

Perspective View

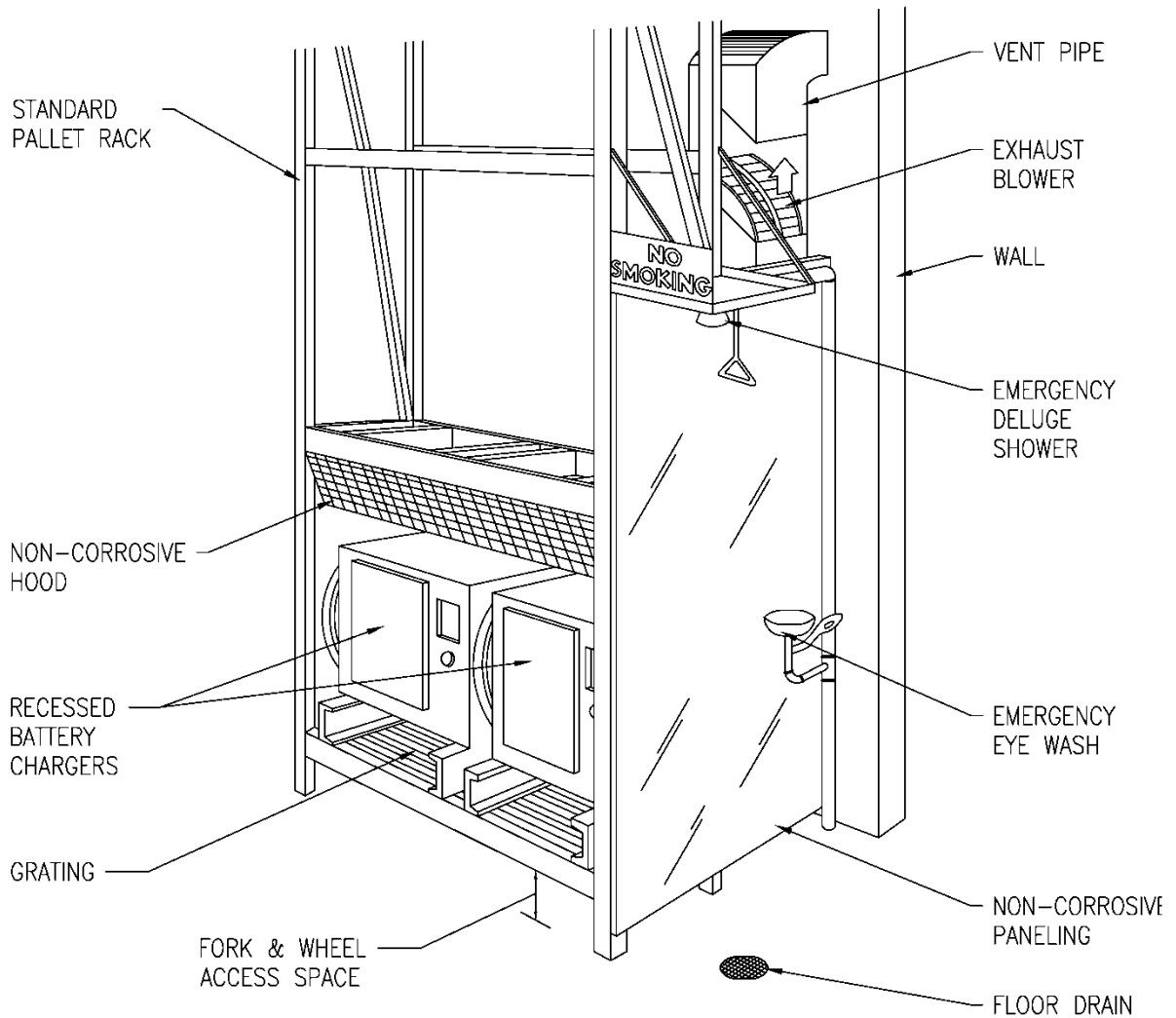

NOTE:
APPLY ACID RESISTANT COATING
TO THE FLOOR.

ALL METAL CHARGER SUPPORTS
TO BE GROUNDED.

\1Note: Refer to paragraph *Containment Pit* for spill containment requirement. /1/.

3-7.10.3 Battery Handling Equipment

Provide specialized battery handling equipment in battery charging and work areas. Equipment used must be selected based on the characteristics of the vehicle and battery being serviced, the activity of the charging station, and the maintenance work performed on the battery. Devices include handling beams, jib hoists, special charging stations, and battery transporters.

3-7.10.4 Ventilation

Provide ventilation in accordance with UFC 3-410-04N, *Industrial Ventilation*.

Provide natural and mechanical exhaust ventilation to ensure diffusion of the gases from the battery and to prevent the accumulation of an explosive mixture. Provide ventilation to limit hydrogen gas buildup to no more than 1 percent by volume in room air. If battery charging room air is air conditioned as part of a general building air conditioning system, exhaust air directly to the outdoors and do not return it to the air distribution system. Required air changes must be based on the expected activity in the charging room, but must be no less than six air changes per hour. Activity must consider the number of cells being charged at a given time and the charging current being used. Provide an air velocity rate across battery charging shelves of at least 125 feet per minute (0.64 meters per second). Interlock the ventilation system with the chargers to prevent charger operation unless the ventilation system is operating.

3-7.11 Pallet Racks

Selective pallet racks (see figure 3-14) consist of uprights, pallet beams, bracing, and miscellaneous accessories. Minimum design load must be 3,000 pounds (1360 kg) per pallet.

Figure 3-14 Pallet Rack Terminology

Perspective Views

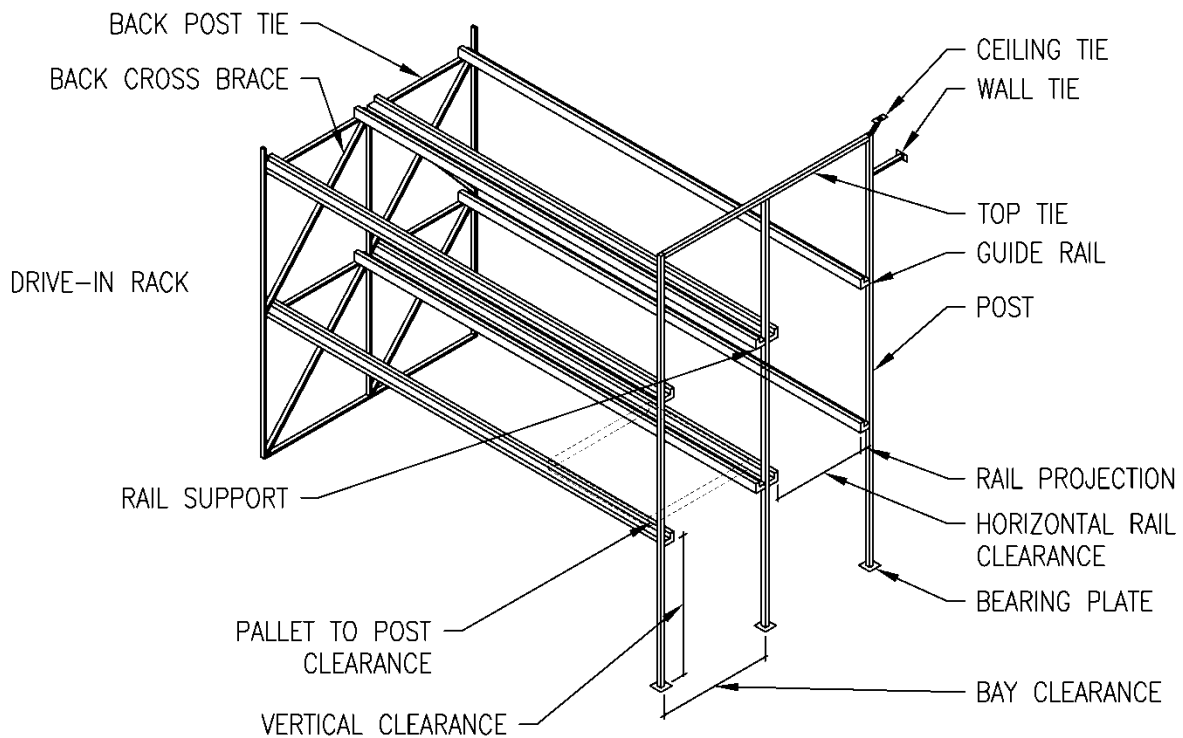
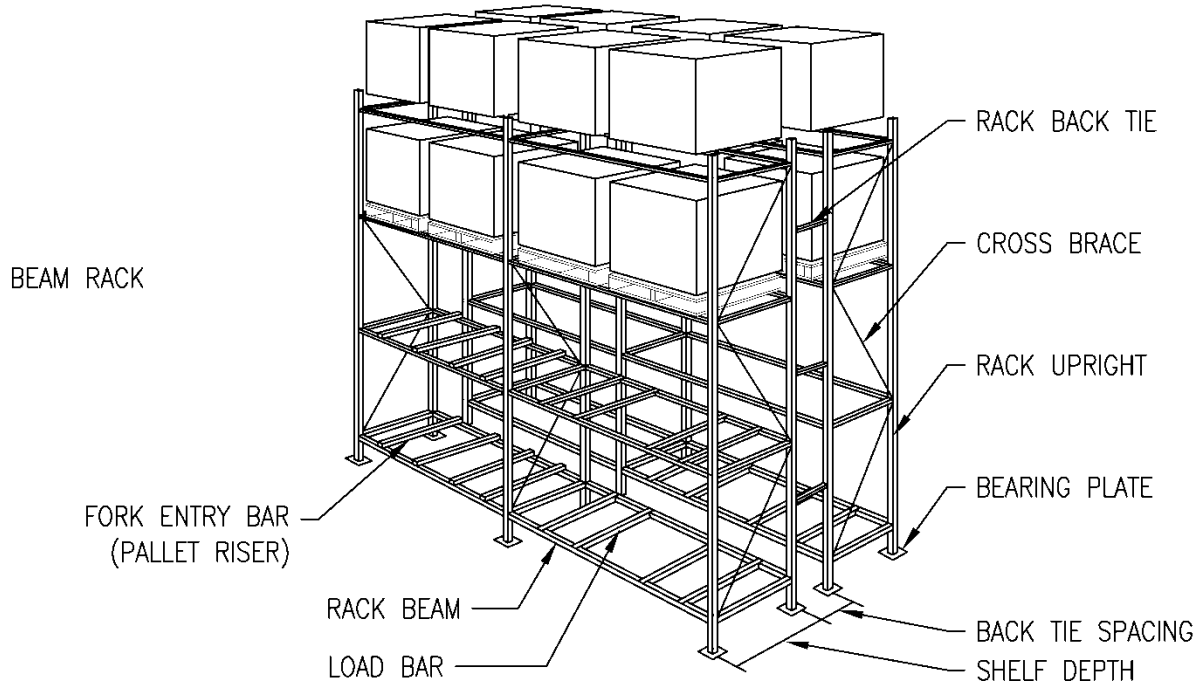

3-7.11.1 Dimensions

Pallet racks must have a 40-inch (1020 mm) depth and accommodate standard 40- x 48-inch (1020 mm x 1220 mm) pallets without front or rear pallet overhang (see figure 3-15). Use of other sizes of pallet racks or pallets must be documented and justified. Beam to beam vertical spacing averages 48 inches (1220 mm) (see figure 2-2).

Figure 3-15 DoD Pallet Arrangement

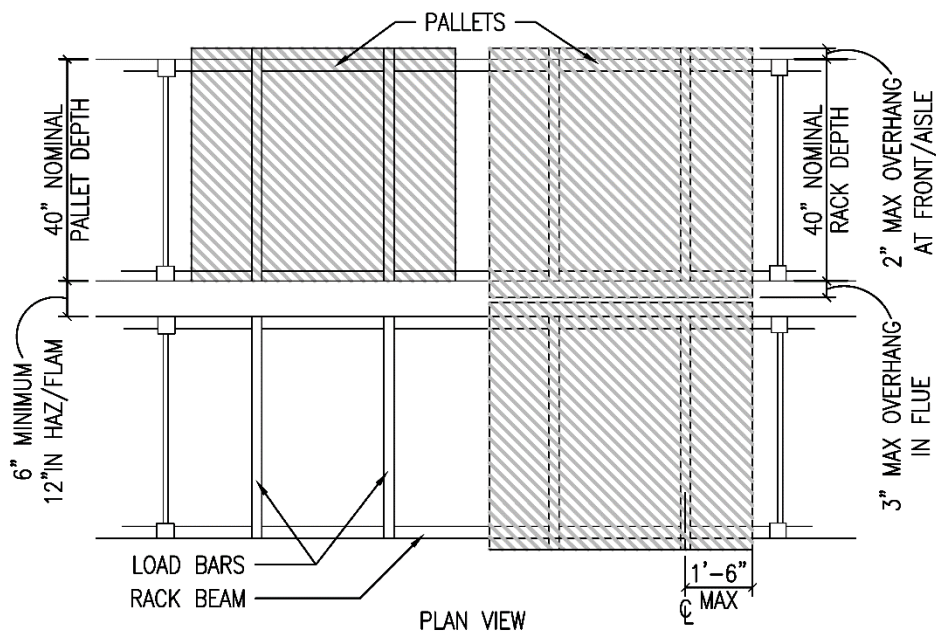
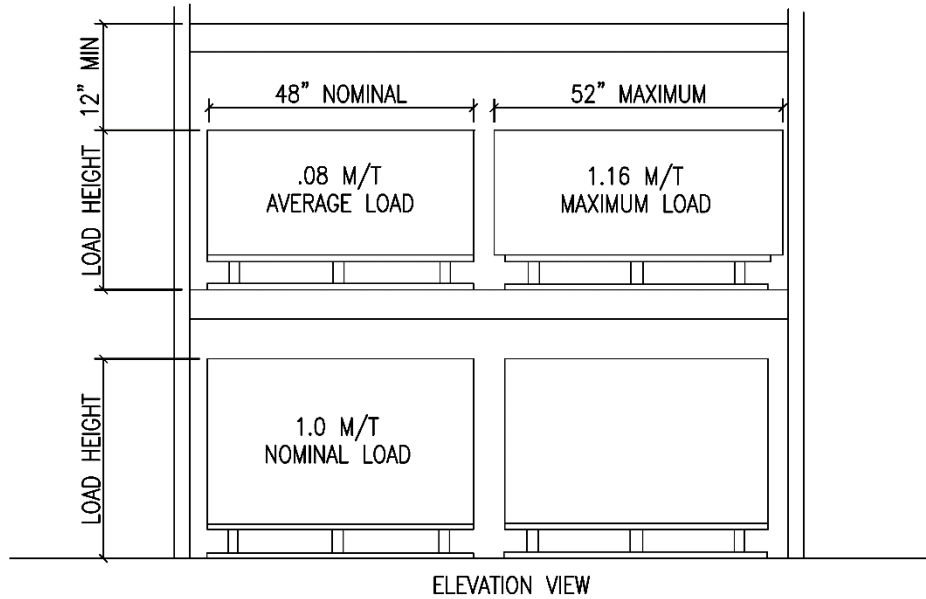

3-7.11.2 Stability

Rack stability is influenced by loading conditions, attachment, and rack assembly. Racks exceeding a 6:1 height to depth ratio must be securely anchored or braced externally. For standard racks, this applies to racks exceeding 20 feet (6096 mm) in height.

3-7.11.3 Flue Space

Flue space must comply with National Fire Protection Association (NFPA).

- Fire protection requirements dictate a minimum longitudinal flue space (figure 3-16) of 6 inches (150 mm).
- Flues must be 12 inches (300 mm) deep in refrigerated areas.
- In hazardous materials storage areas, provide 12-inch (300 mm) flues between back-to-back racks. Flues of 8-12 inches (200-300 mm) must be provided between backs of racks and walls.
- Standard pallet racks provide a minimum 4-inch (100 mm) transverse flue space.

Figure 3-16 Pallet Rack Fire Protection Terminology

Perspective View

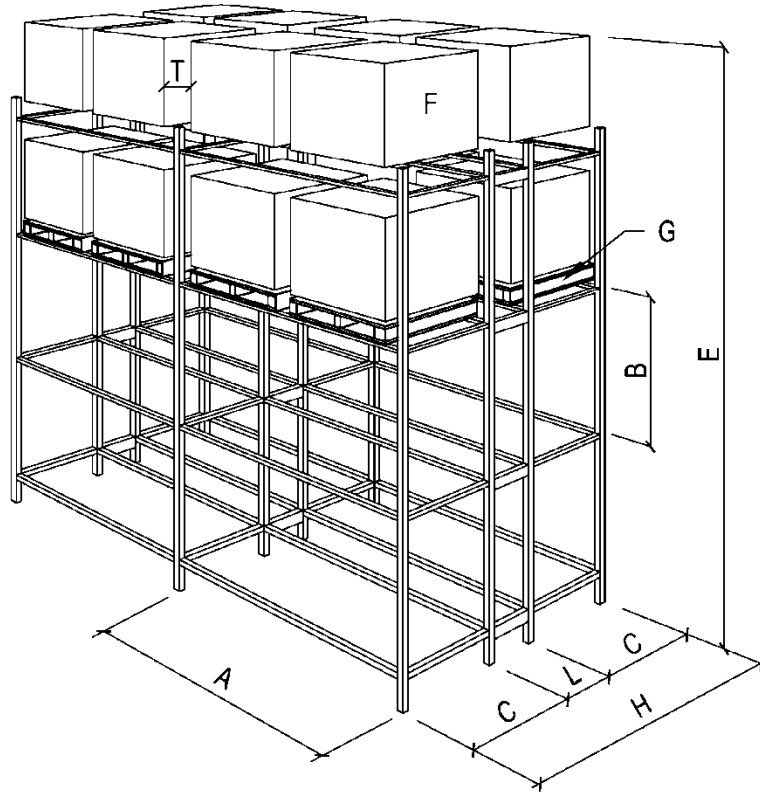

LEGEND

- A – SHELF WIDTH
- B – SHELF HEIGHT
- C – SHELF DEPTH
- T – TRANSVERSE FLUE SPACE
- L – LONGITUDINAL FLUE SPACE
- E – STORAGE HEIGHT
- F – COMMODITY
- G – PALLET
- H – RACK DEPTH

3-7.11.4 Attachment

Securely attach all pallet racks to floors, walls, and each other, to ensure stability and safety.

3-7.11.5 System Interface

Interface operations with pallet rack using pickup and delivery (P&D) stations, as illustrated in figure 3-17. Provide additional cross-aisle width to accommodate these P&D stations.

Figure 3-17 Pickup and Delivery (P&D) Stations

Perspective Views and Plan Views

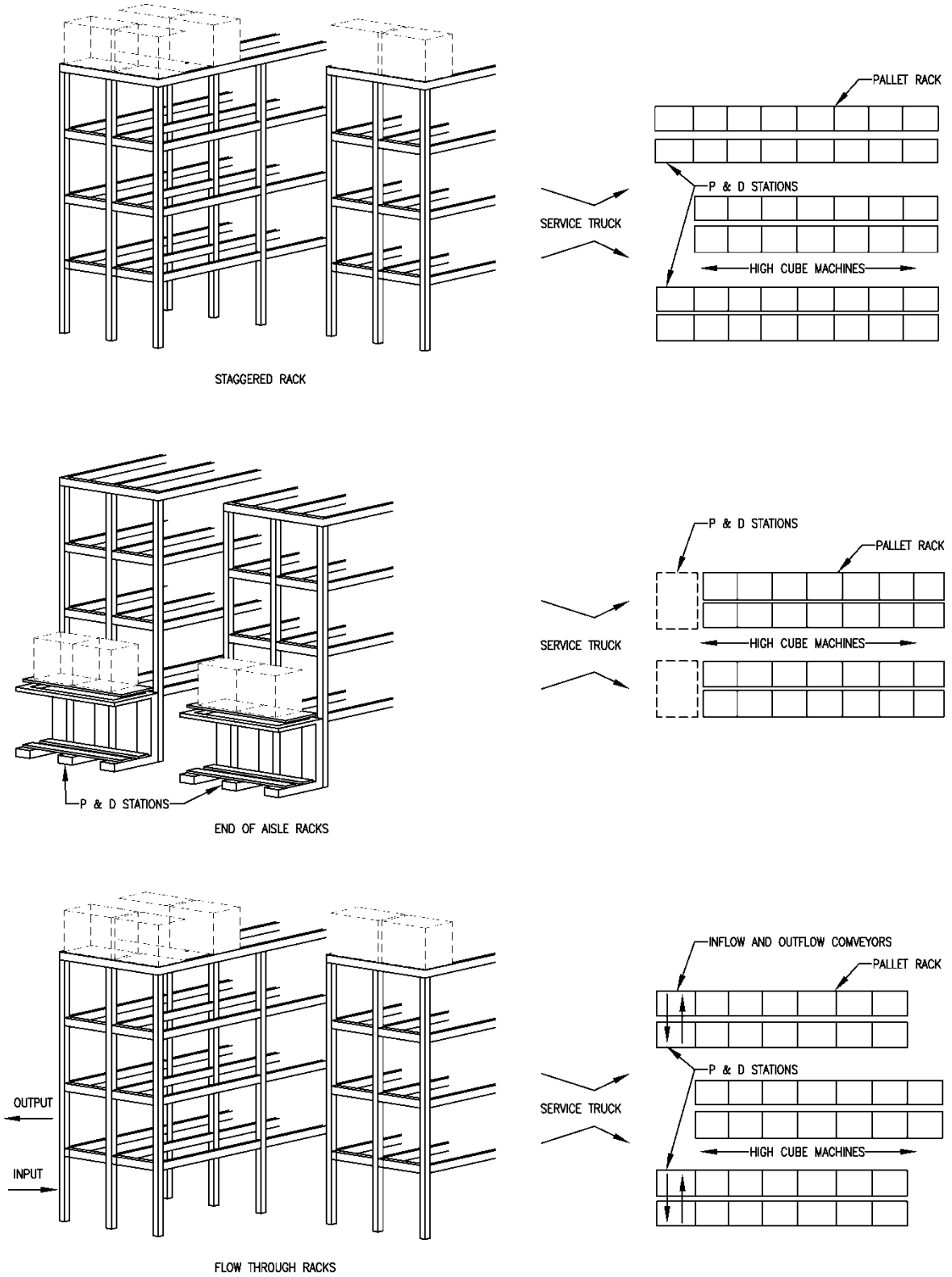

3-7.12 Aisle Dimensions

Coordinate aisle dimensions with specific equipment requirements. Observe the following:

3-7.12.1 Rail Guidance

Coordinate rail locations with pallet rack and vehicle characteristics (see figure 3-18). Provide sufficient cross aisle width to accommodate the entrance flare.

Figure 3-18 Typical Rail Guidance System

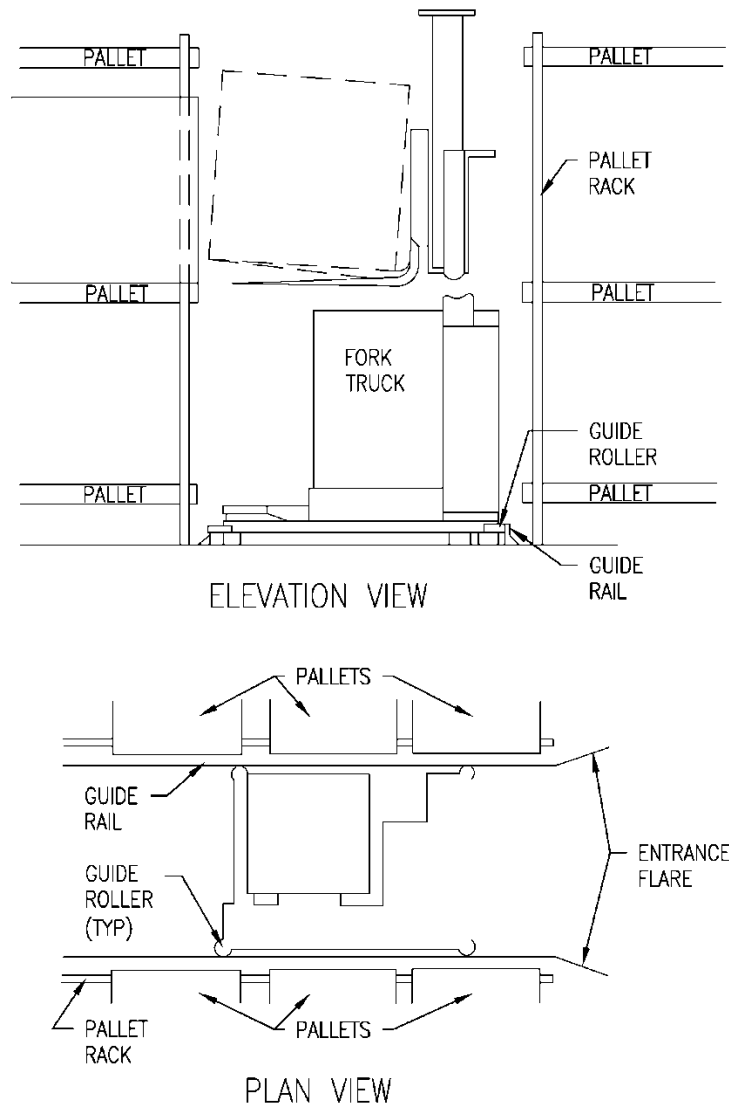

3-7.12.2 Wire Guidance

Coordinate guide wire locations with pallet rack and vehicle characteristics (see figure 3-19). Review guide wire location plan to provide a continuous loop and avoid crossovers. Install loop driver and control panel in a protected location.

Figure 3-19 Typical Wire Guidance System

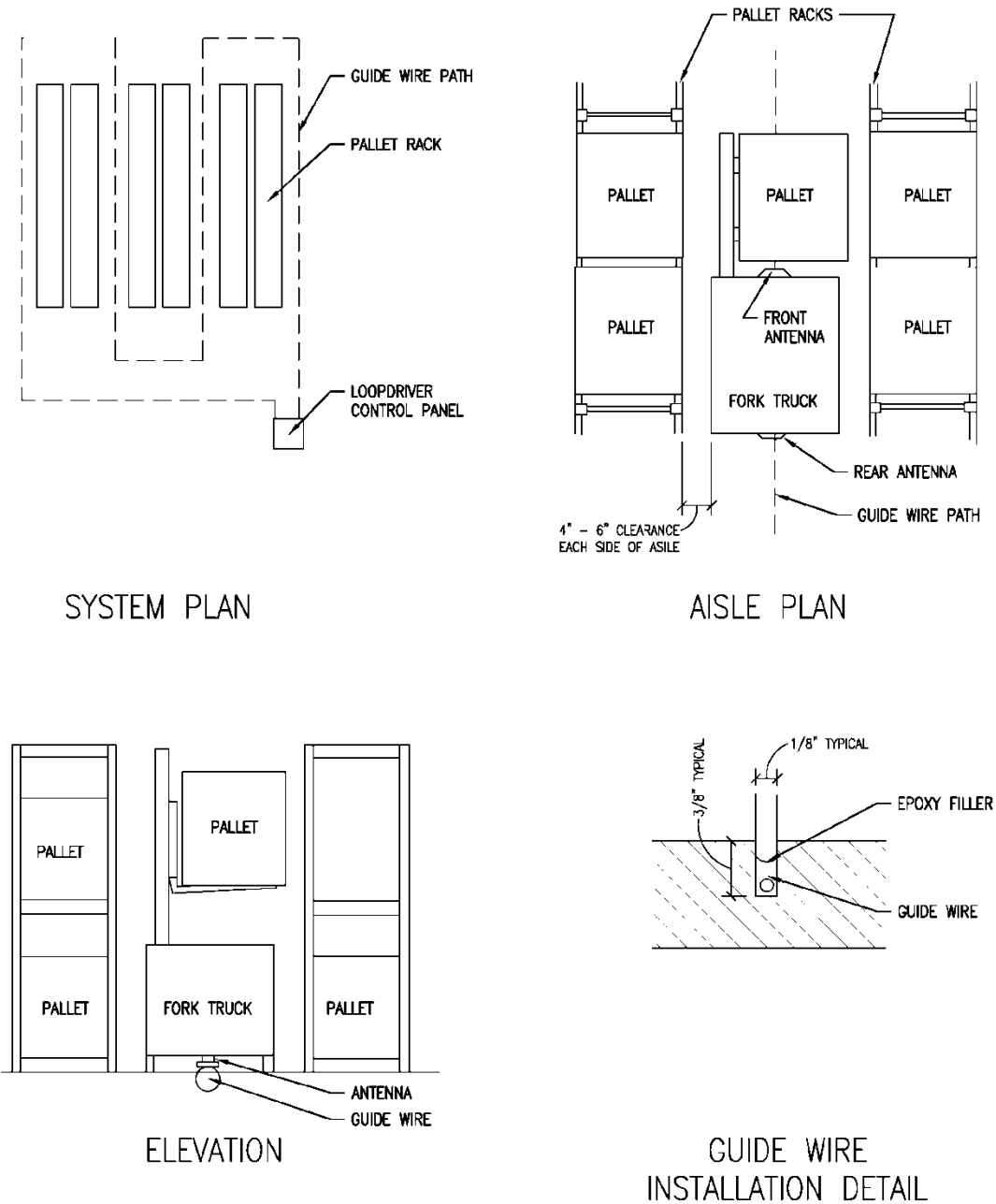

3-7.12.3 Transport Aisles

Width of transport aisles must be at least twice the vehicle width plus 18 inches (145 mm) to permit two-way traffic.

3-7.12.4 Fire Protection

Aisle width will affect sprinkler requirements and water demand.

3-7.13 Building Bay Dimensions

Modular building dimensions must be developed considering the relationship between column spacing, rack dimensions, aisle patterns, machinery and operations. Apply a 33 ft. x 64 ft. (10,060 mm x 19,510 mm) bay size when warehouse construction must be planned without knowledge of specific warehousing systems to be installed within new facilities. The universal bay size will not represent the optimum column spacing for every system. Figure 3-20 illustrates column spacing parameters which affect bay dimensions. For large facilities designed for a specific system, greater utilization of building area will be obtained by selecting a column spacing matching the requirements of the material handling system.

Figure 3-20 Building Column Spacing Parameters

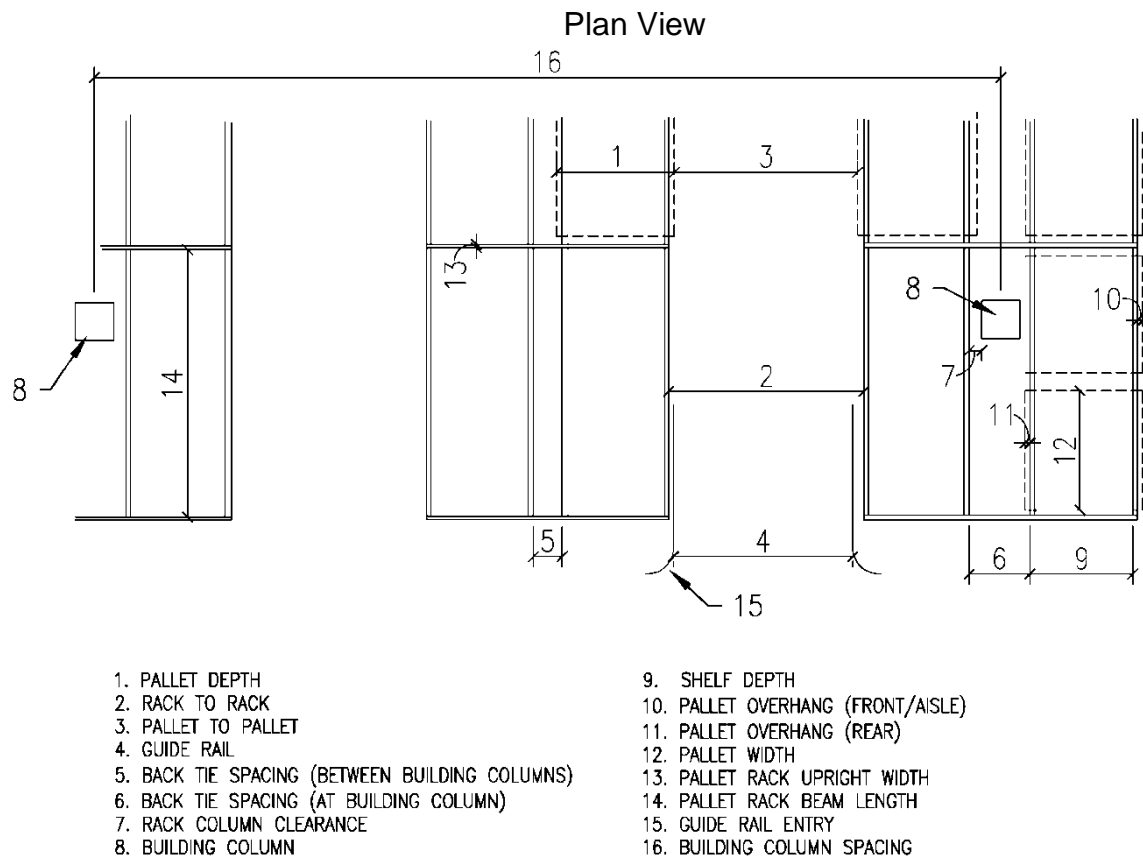

3-7.13.1 Universal Bay Size

If a general purpose facility is required, or a specific materials handling system has not been selected, maintain versatility in selecting the universal pattern subject to the following considerations:

- a. The universal pattern will not represent the optimum spacing for all systems.
- b. The facility may be costlier than necessary because of the inefficient use of space. A smaller building can generally be constructed if the optimum column spacing is used.
- c. Use of the universal pattern will permit the building to fulfill a variety of missions due to its ability to function with many materials handling systems.

3-7.13.2 Optimum Bay Size

Use of the optimum bay size for a particular materials handling system will provide the most efficient use of the building area. In addition:

- a. Use of the optimum bay size will reduce the size of the required building due to more efficient use of the building cube.
- b. Ultimate versatility of the facility will be reduced because the column pattern will not fit every system.

3-7.13.3 Comparison of Bay Sizes

The information presented in table 3-5 provides comparison information to enable a designer to measure the effects of changes to the building bay size. Use of the universal bay size results in an average 7 percent increase in required building area.

Table 3-5 Building Bay Size Comparison

SYSTEM	OPTIMUM BAY SIZE ft-in x ft-in (mm x mm)	MODULAR EQUIVALENT BAY SIZE ft-in x ft-in (mm x mm)	BAY DIMENSION FOR FIT ft-in (mm)	SPACE UTILIZATION IN UNIVERSAL BAY %
Counterbalance Truck	39'-2" x 39'-2" (11,940 x 11,940)	39'-2" x 58'-4" (11,940 x 17,780)	64'-0" (19,510)	91.1%
Reach Truck	30'-2" x 44'-10" (9,190 x 13,670)	30'-2" x 44'-10" (9,190 x 13,670)	33'-0" (10,060) 64'-0" (19,510)	91.4% 92.9%
Front/Side-loader Truck Turret Truck Man-Up Turret Truck	26'-2" x 38'-10 (7,980 x 11,840)	26'-2" x 38'-10" (7,980 x 11,840) 26'-2" x 64'-2" (7,980 x 19,560)	33'-0" (10,060) 64'-0" (19,510)	79.3% 100.3%
Hybrid Truck	24'-2" x 35'-10" (7,370 x 10,920)	24'-2" x 59'-2" (7,370 x 18,030)	64'-0" (19,510)	92.4%
Manual Order Picker	31'-0" x 49'-0" (9,450 x 14,940)	31'-0" x 61'-0" (9,450 X 18,590) 31'-0" x 61'-0" (9,450 X 18,590)	33'-0" (10,060) 64'-0" (19,510)	93.9% 95.3%
Order Picking Truck	33'-0" x 49'-0" (10,060 x 14,940)	33'-0" x 59'-0" (10,060 X 17,980) 33'-0" x 59'-0" (10,060 X 17,980)	33'-0" (10,060) 64'-0" (19,510)	100.0% 92.2%
Manned S/R Machine	31'-0" x 49'-0" (9,450 x 14,940)	31'-0" x 61'-0" (9,450 X 18,590) 31'-0" x 61'-0" (9,450 X 18,590)	33'-0" (10,060) 64'-0" (19,510)	93.9% 95.3%
Carousel	32'-6" x 45'-6" (9,910 x 13,870)	32'-6" x 45'-6" (9,910 x 13,870) 32'-6" x 58'-6" (9,910 x 17,830)	33'-0" (10,060) 64'-0" (19,510)	98.5% 91.4%
Mini-S/R Machine	26'-0" x 51'-0" (7,920 x 15,540)	26'-0" x 63'-6" (7,920 x 19,350) 26'-0" x 63'-6" (7,920 x 19,350)	33'-0" (10,060) 64'-0" (19,510)	78.8% 99.2%

3-7.13.4 Clear Storage Height

For clearance requirements between top of storage load and any overhead obstructions and sprinklers refer to NFPA 13. Refer to DOD 4140.1-R, *DoD Supply Chain Material Management Regulation* for details.

Consider the following:

- Clearance from sprinkler deflectors to the top of storage load will affect sprinkler requirements and water demand.
- Clear building height requirements for specific levels of storage, as well as three modular clear heights covering a range of storage levels, are summarized in table 3-6. Construction of a warehouse facility to a modular height greater than that required for the desired system or level of storage will result in an unutilized cube and extra construction and operating costs.

Table 3-6 Required Clear Building Heights

SYSTEM	PALLET STORAGE LEVELS								
	2	3	4	5	6	7	8	9	10
Counterbalance truck	8'-6" (2,590 mm)	12'-6" (3,810 mm)	18'-0" (5,490 mm)	22'-0" (6,700 mm)	--	--	--	--	--
Reach Truck	9'-6" (2,900 mm)	13'-6" (4,110 mm)	19'-0" (5,790 mm)	23'-0" (7,010 mm)	--	--	--	--	--
Front/Side-loader	8'-6" (2,590 mm)	12'-6" (3,810 mm)	18'-0" (5,490 mm)	22'-0" (6,700 mm)	26'-0" (7,920 mm)	30'-0" (9,140 mm)	34'-0" (10,360 mm)	--	--
Turret Truck	8'-6" (2,590 mm)	12'-6" (3,810 mm)	18'-0" (5,490 mm)	22'-0" (6,700 mm)	26'-0" (7,920 mm)	30'-0" (9,140 mm)	34'-0" (10,360 mm)	38'-0" (11,580 mm)	42'-0" (12,800 mm)
Man-Up Turret Truck	8'-6" (2,590 mm)	12'-6" (3,810 mm)	18'-0" (5,490 mm)	22'-0" (6,700 mm)	26'-0" (7,920 mm)	30'-0" (9,140 mm)	34'-0" (10,360 mm)	38'-0" (11,580 mm)	42'-0" (12,800 mm)
Hybrid	--	--	--	--	--	31'-6" (9,600 mm)	35'-0" (10,670 mm)	39'-6" (12,040 mm)	43'-6" (13,260 mm)
SYSTEM	STORAGE UNIT LEVELS								
	1		2	2	3	4		5	Other
Manual Order Picker	9'-0" (2,740 mm)	--	18'-0" (5,490 mm)	--	26'-0" (7,920 mm)	--	--	--	--
Order Picking Truck	--	--	17'-0" (5,180 mm)	--	24'-0" (7,310 mm)	31'-0" (9,450 mm)	--	38'-0" (11,580 mm)	--
Manned S/R Machine	--	--	--	--	24'-0" (7,310 mm)	31'-0" (9,450 mm)	--	38'-0" (11,580 mm)	--
Carousel	10'-0" (3,050 mm)	--	--	20'-0" (6,100 mm)	29'-0" (8,840 mm)	--	--	--	--
Mini-S/R Machine	--	--	--	--	24'-5" (7,440 mm)	--	--	34'-6" (10,510 mm)	44'-7" (13,590 mm)
Modular Building Clear Height	19'-0" (5,790 mm)			31'-0" (9,450 mm)			47'-0" (14,330 mm)		
Height Use Efficiency	47% - 105%			65% - 100%			73% - 95%		

Notes:

- Hybrid Truck Storage above 10 levels is not listed.
 - Clear height includes sprinkler clearances per NFPA 13. Clear height does not include clearance allowance for draft curtains.
 - Pallet storage levels based on a standard 48 in (1220 mm) vertical spacing.
 - Height use efficiency is ratio of required clear building height to modular building clear height.
- (1) 20 ft (6,096 mm) high system.
(2) 30 ft (9,144 mm) high system.
(3) 40 ft (12,192 mm) high system.

3-7.14 Telecommunication Systems

Provide telephones, service entrances, telephone cabinets, conduit runs, and telephone outlets. Locate at least one telephone in each office. Provide in accordance with UFC 3-580-01 *Telecommunications Building Cabling Systems Planning and Design*.

3-7.14.1 Navy and Marine Corps

For Navy and Marine Corps projects use UFC 3-580-10 *Navy and Marine Corps Intranet (NMCI) Standard Construction Practices* where NMCI is a requirement.

3-7.14.2 Army

For Army projects, building telecommunications must be designed to satisfy Army Installation Information Infrastructure Architecture (I3A) Policy.

3-7.15 Alarm Systems

Provide fire, hydrogen, ventilation failure, hazardous chemical spill, neutralizer tank and security alarms.

3-7.15.1 Fire Alarms

Provide storage facilities with fire alarm system that transmits a signal to the fire department, in accordance with UFC 3-600-01, *Fire Protection Engineering for Facilities*.

3-7.15.2 Hazardous Chemical Spill Alarms

Provide hazardous chemical storage areas with alarms signaling release or spillage of stored chemicals.

3-7.15.3 Security Alarms

Protect stored materials with Electronic Security Systems (ESS) when required by Agency policies and as defined by the DoD Security Programs Guidance.

3-7.16 Casework

Counters, casework, and cabinets must be of high-quality and durable construction. Specify Architectural Woodwork Institute (AWI) Premium or Custom for finishes per AWI Quality Standards Illustrated. Casework, cabinet doors, and drawer faces must be provided as veneer panel core. Doors, drawers, and casework faces must be plastic laminate at a minimum. Countertops are to be solid surface/solid composite plastics only. Specify .75-in. (20-mm) minimum thickness for plywood, plywood backing, and solid wood panels.

3-7.17 Elevators and Lifts

Elevators may be needed if required for ADA/ABA compliance or the activity specifically requests an elevator. See the section on Accessibility for further clarification.

Size elevator based on activity requirements. If elevators are required at least one elevator must accommodate a 24 in. wide x 84 in. long (610 mm x 2,134 mm) emergency stretcher.

3-7.18 Furniture Considerations

Coordinate with the Comprehensive Interior Design package during the design process. All case goods and hardware will be coordinated with the Structural Interior Design package for the project to ensure matching woods, stains, and finishes as best possible. Selection of materials and finishes for the main entry point area(s) will accommodate heavy use.

3-7.19 Equipment Considerations

Coordinate the use and location of recycling centers throughout the common areas to complement the interior design while supporting sustainability guidance.

All appliance colors must be coordinated with the FF&E. The construction contractor or design/build contractor will submit cut/datasheets of proposed equivalents/substitutions appliances for review/approval. Purchase appliances meeting Energy Star program standards and specifications as included in this guide. Qualifying products are listed on the Energy Star website.

3-8 PEST CONTROL

Incorporate pest control measures into building design to ensure the efficient control and quarantine of insects, rodents, and other pests. Refer to Armed Forces Pest Management Board Technical Guide No. 17, *Military Handbook – Design of Pest Management Facilities*. Measures must include:

- a. Establishment of construction needs and maintenance criteria for prevention of pests.
- b. Land drainage; clearing and control of vegetation in outside storage and pest breeding areas.
- c. Application of pesticides on materials, in buildings, on the ground, and as soil treatment.
- d. Use of wood preservatives

3-9 ACCESSIBILITY FOR THE DISABLED

Every facility must be designed to ensure access in accordance with UFC 1-200-01, *General Building Requirements*.

3-10 ACOUSTICS

Design the facility to provide a comfortable acoustical environment and provide comprehensive sound isolation and sound absorption measures for individual spaces as appropriate. Provide acoustical design to prevent sound from noisy spaces such as corridors, toilets, elevator machine rooms, and mechanical rooms from having negative impact on the adjacent spaces.

Use the “suggested design values” STC ratings in UFC 3-450-01, *Noise and Vibration Control*, as the basis for the sound design of partition, door and window assemblies for the facility. Utilize gypsum board wall “improvements” to increase the STC of gypsum board “stud type” partitions to achieve the project sound requirements. Unless noted otherwise extend partitions and seal to the structure above around rooms that have a noise source such as but not limited to corridors, toilets, elevator machine rooms, training rooms, maintenance rooms, activity rooms, and mechanical rooms. Unless indicated in chapter 4, STC ratings do not need to be field verified. Do not provide any special acoustical conditions in the project unless specifically recommended by an acoustical study.

3-11 CONVEYING SYSTEMS

Conveying systems may not be required. For projects which require conveying systems, provide them in accordance with the following:

3-11.1 Overhead Bridge Cranes

Verify the crane capacity with the governing authority, but provide no less than a 5 ton (4.5 metric ton) overhead bridge crane. All cranes must be Duty Service Class C. All bridge cranes must be supported from patented track systems designed by the crane manufacturer. All overhead bridge cranes must be under running, double girder electric cranes.

Provide all cranes in accordance with Air Force Instruction 91-203, Air Force Consolidated Occupational Safety Instruction; Navy Crane Center Instruction 11450.2, *Design of Navy Shore Weight Handling Equipment*; title 29 CFR 1910.179(j), *Inspections*; title 29 CFR 1910.179(k), *Testing*; and the American National Standards Institute ANSI MH27.1, *Specifications for Patented Track Underhung Cranes and Monorail Systems*; and relevant portions of the Crane Manufacturing Association of America CMAA Specification 70, *Top Running Bridge and Gantry Type Multiple Girder Electric Overhead Traveling Cranes*, and the Crane Manufacturing Association of America CMAA Specification 74, *Top Running and Under Running Single Girder Electric Overhead Cranes Utilizing Under Running Trolley Hoist*.

3-11.1.1 Hook Height

Hook height is to the saddle of the hook and must be determined by the overall height of the facility. Hook height for any facility must be no less than 20 feet (6.10 m).

3-11.1.2 Hook Coverage

The bridge crane must provide loaded hook coverage to within 12 feet (3.66 m) of the inside face of all walls and to within 15 feet (4.57 m) of the inside face of the warehouse dock doors. Where multiple cranes are provided, fully loaded hooks must be capable of locating within 15 feet (4.57 m) of each other.

3-11.1.3 Travel Speeds

Overhead bridge cranes must have electric motorized bridge, trolley and hoist. One crane must be used per warehouse module, with the bridge designed to travel the full width of the module. Trolley and bridge must be capable of operating at a slow speed of 15 to 20 ft/min (0.07 to 0.1 m/s) for positioning loads and at a high speed for moving loads of 60 ft/min (0.3 m/s); the hoist must be capable of operating at a slow speed of 3 to 4 ft/min (0.01 to 0.02 m/s) and at a high speed of 12 ft/min (0.06 m/s). Refer to UFGS 41 22 13.13 *Bridge Cranes* and UFGS 41 22 13.15 *Bridge Cranes, Overhead Electric, Under Running*.

3-12 MOTOR AND CONTROLS

Bridge, trolley and hoist controls must provide for two-speed reversing of a two-speed, squirrel-cage motor. The controls must be equipped with reduced voltage starting for the motors. Controls must be operable from the floor.

Provide service catwalks or platforms to maintain overhead bridge cranes. Ensure all safety requirements are met; see UFGS 01 35 26, *Governmental Safety Requirements*. The access must be from inside the warehouse.

3-13 PLUMBING

3-13.1 General

Provide plumbing in accordance with UFC 1-200-01, *General Building Requirements* and UFC 3-420-01, *Plumbing Systems*.

3-13.1.1 Emergency Shower / Eyewash Fixtures and Floor Drains

Provide emergency eyewash/shower fixtures and drainage system as required by this UFC and in accordance with UFC 3-420-01, *Plumbing Systems*.

3-13.2 Compressed Air

Provide compressed air where required by the governing authority.

3-14 ENVIRONMENTAL CONTROL

Provide heating in all offices in all heating zones. Provide air conditioning in offices. Determine requirements for environmental control in storage space based on the temperature requirements of material stored and the extent and activity level of occupancy. Need for heating of storage spaces must be clearly demonstrated. Warehouses for storage of materials not subject to freezing must not be heated. In warehouses containing materials subject to freezing, design heating system to maintain an inside winter temperature of 45°F (7°C). Maintain a temperature of 55°F (13°C) in warehouse areas with active employment. Refer to UFC 3-410-01, *Heating, Ventilating, and Air Conditioning Systems*.

The designer must consider a minimum of three HVAC systems that meet all the criteria and perform a life cycle cost analysis for the basis of selection. Refer to UFC 1-200-02, *High Performance and Sustainable Building Requirements* and UFC 3-410-01, *Heating, Ventilating, and Air Conditioning Systems*.

3-14.1 General

Provide HVAC in accordance with UFC 1-200-01, *General Building Requirements* and Unified Facilities Criteria series 3-400, *Mechanical*.

3-14.2 Heating

Provide heating in accordance with UFC 3-410-01, *Heating, Ventilating, and Air Conditioning Systems* and as follows:

- The heating system must be a steam, hot water, gas fired hot air, or solar system. Provide unit heaters or hot air registers at cargo doors and over aisles between stored materials.
- Direct-fired hot air systems must not be used for hazardous materials warehouses.
- Selection of unit heaters, spot heating systems, and design of total heating systems, must be considered on energy and life-cycle cost basis.

3-14.2.1 Heating Plant

The heating plant must be located in a mechanical room with no access to the storage area. When the mechanical room is located inside the warehouse, the following must be observed:

- a. Provide a wall with a 2-hour fire resistance rating between the heater room and storage area.
- b. All access to the heating area must be from the outside only.

- c. When infrared unit heaters are used, provide safe clearances in accordance with the manufacturer's safety instructions.

3-14.2.2 Infiltration Rate

Design for an infiltration rate of two air changes per hour in the warehouse area. This rate is dependent upon the installation of dock door seals.

3-14.2.3 Radiant Floor Heating System

Investigate the use of an under floor heating system for the warehouse storage areas.

Under floor heating systems must be 2 in. minimum and 3 in. maximum (50.8 mm and 76.2 mm) from the bottom of the floor slab. Depth of under floor heating system and slab thickness must be coordinated with the rack / shelving fastener depth to avoid conflict and damage to the heating system.

3-14.2.4 Cold Jet Destratifiers

Consider the installation of cold jet destratifiers based on an economic analysis.

3-14.2.5 High Volume Low-Speed Fans

Consider the installation of high volume low-speed (HVLS) fans based on an economic analysis.

3-14.2.6 Space Thermometer

A switch activated by opening the dock doors must override the space thermostat to stop the heating equipment in the warehouse area. Provide a minimum temperature thermostat field set at 34°F (1°C) to override the heating deactivation switch during door-open periods of subfreezing ambient temperatures. After the doors are closed, the room thermostat must assume control. Heating system recovery time must be a maximum of 60 minutes after the doors are closed.

3-14.2.7 Automatic Thermostatic Control

The automatic thermostatic control must meet the requirements of UFC 3-410-01, *Heating, Ventilating, and Air Conditioning Systems*.

3-14.2.8 Heating Zones

Provide heating zones to maximize energy savings and to meet sustainability requirements.

3-14.3 Ventilation

Provide ventilation in accordance with UFC 3-410-01, *Heating, Ventilating, and Air Conditioning Systems*, and UFC 3-410-04N, *Industrial Ventilation*.

Toxic fumes generated by gas powered fork trucks must be exhausted. It is recommended that gas powered fork trucks not operate inside the warehouse area.

3-14.4 Humidity Control

Provide humidity control in accordance with UFC 3-410-01, *Heating, Ventilating, and Air Conditioning Systems*, and UFC 3-410-04N, *Industrial Ventilation*.

3-14.5 Air Conditioning

Provide air conditioning in accordance with UFC 3-410-01, *Heating, Ventilating, and Air Conditioning Systems*.

Office areas in cooling zones must be air-conditioned by either high efficiency small area units or a central system, as appropriate. Consider radiant floor cooling systems for air conditioned storage areas.

3-14.6 Energy Conservation

Provide energy conservation measures to meet the project sustainability requirements. Refer to UFC 1-200-02, *High Performance and Sustainable Building Requirements*.

3-14.7 Insulation

Warehousing facilities that require heating or cooling must be insulated. Determine the amount and type of insulation by a life-cycle cost analysis.

3-14.8 Mechanical Equipment Requirements

3-14.8.1 Corrosion Protection

Provide special finish coatings on the interior and the exterior surfaces of HVAC equipment exposed to the weather, including all coil surfaces and interior equipment surfaces belonging to the first HVAC equipment (excluding louvers) in the supply ductwork system that is subjected to outside supply air. The coating must not act as an insulating barrier to the HVAC heat exchange capability. Unit casing – standard factory paint is not acceptable. Specify appropriate protection requirements, salt test hours of at least 3,000 hours. Coils must be copper tube/copper fin with a phenolic type coating applied by immersion. Spray-on coatings are not allowed.

Equipment located inside that handles outside air:

- Evaluate the outside air percentage; copper tube/copper fin or copper tube/aluminum fin with phenolic coating is suitable for low outside air percentages.
- Evaluate cooling and heating capacity reductions resulting from phenolic coating application whose thickness is typically three mils thick.

- Consider using copper tube / copper fin with phenolic type coating for 100 percent outside air units.

3-14.9 Noise and Vibration Control

Design mechanical systems and equipment to limit noise and vibration in accordance with UFC 3-450-01, *Noise and Vibration Control*.

3-15 FIRE PROTECTION

Provisions for fire protection and life safety will conform to National Fire Protection Association (NFPA) *Life Safety Code* NFPA 101, UFC 1-200-01, *General Building Requirements* and UFC 3-600-01, *Fire Protection Engineering for Facilities*.

3-15.1 Fire Protection Sprinkler Systems

For new construction and rehabilitation projects, install sprinkler systems in accordance with National Fire Protection Association (NFPA) *Standard for the Installation of Sprinkler Systems* NFPA 13 and UFC 3-600-01, *Fire Protection Engineering for Facilities*.

The following must be considered:

- a. Coordinate location of ceiling mounted fixtures including destratification units with the placement of sprinklers.
- b. The type of sprinkler protection provided and the water supply requirements can vary based on the following:
 - Clearance from the sprinkler deflector to the top of storage
 - Aisle width
 - Storage height
 - Storage configuration
 - Type of storage (commodity)
 - If the commodity is encapsulated or nonencapsulated
- c. It is recommended to provide sprinkler protection that does not require in-rack sprinklers. Control Mode Specific Application (CMSA) and Early Suppression Fast-Response (ESFR) sprinklers can be used. Warehouses with a roof height greater than 15 feet must be protected with the customer defined storage arrangement (i.e., high pile, rack storage, etc.) to the maximum storage height allowable. For example, the sprinkler system for a warehouse using pile storage with a 25 ft roof

height will be designed to a maximum storage height of 22 ft regardless of the defined storage height.

3-15.1.2 Storage System Sprinklers

In general purpose, controlled humidity, refrigerated and other type warehouses where hazardous materials are not to be stored, provide \1\ /1/ face and flue sprinklers per NFPA 13. Rack shelving must not be adjustable on rack levels where \1\ /1/ face and flue sprinklers are provided. Additional flue sprinklers may be required depending upon storage height and its relationship to the \1\ /1/ sprinklers. Face and flue sprinklers must be placed at or below each 108-inch (2745 mm) open frame shelf at the required levels in a manner which prevents sprinkler damage during storage operations, as illustrated in figure 3-21. The sprinklers at all other shelf levels must be capable of vertical adjustment using mechanically grooved fittings.

3-15.1.3 In-Rack Sprinkler System

In-rack sprinklers must be provided in accordance with NFPA 13.

3-15.2 Fire Alarm Systems

Install addressable building fire alarms systems that are compatible with the base system and connect to the base reporting system.

3-15.3 Smoke Detectors

Install smoke detectors in accordance with UFC 3-600-01, *Fire Protection Engineering for Facilities* and NFPA 72, *National Fire Alarm and Signaling Code*.

Figure 3-21 Standard Face and Longitudinal Flue Sprinkler Mounting
 (to Prevent Pallet and Load Interference)
 Detail and Sections

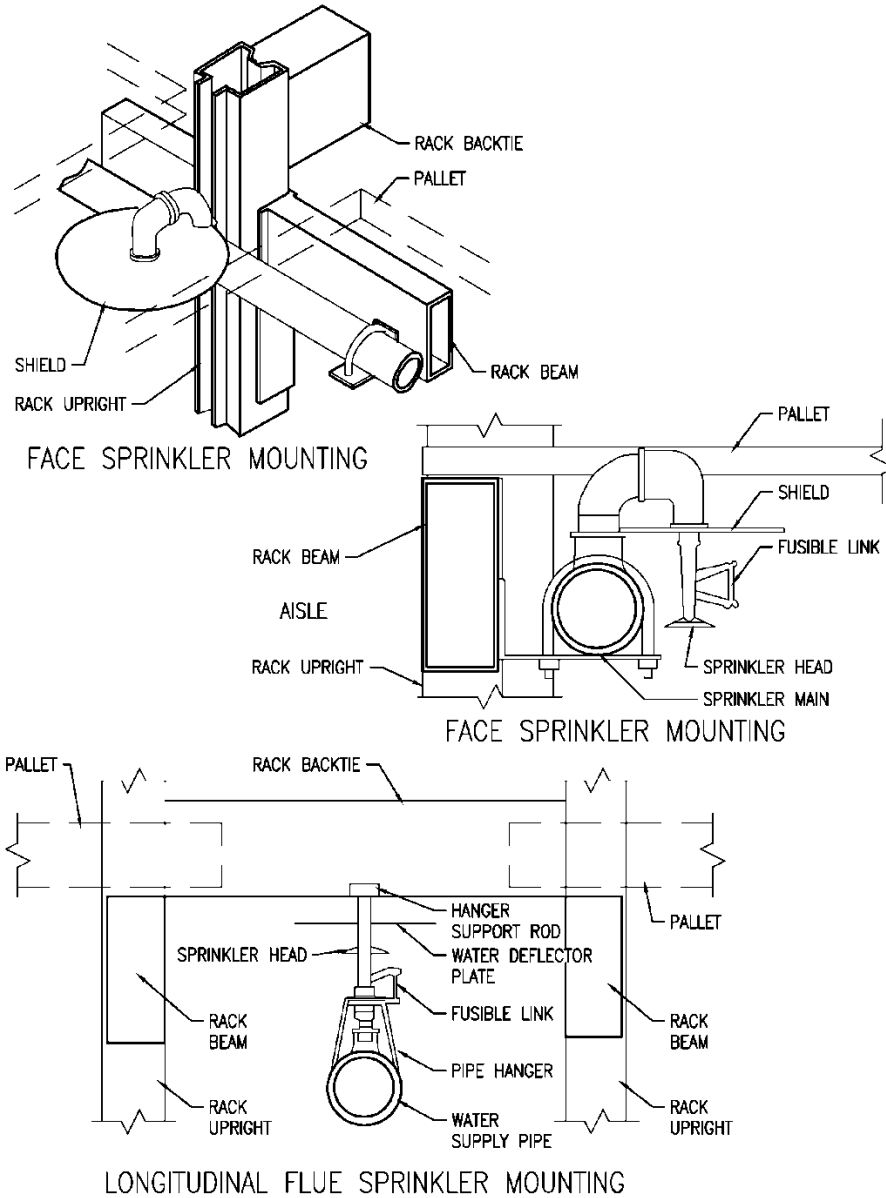

3-16 ELECTRICAL

Provide site electrical utilities, interior distribution systems, communications and security, and site lighting according to UFC 1-200-01, *General Building Requirements*, UFC 3-501-01, *Electrical Engineering* and the latest installation design requirements.

- a. Site Electrical Utilities includes equipment, overhead power distribution, underground electrical systems, grounding, metering, exterior site lighting, and cathodic protection systems.
- b. Site Lighting – Provide lighting to ensure occupants have a means of safely moving between outdoor spaces. Refer to the Installation Appearance Plan (IAP) in the selection of light poles and signs. Provide adequate site lighting at any point where there is a change in grade requiring steps, near handicap and motorcycle parking areas, and near main entrances to buildings. Provide exterior lighting in parking areas, building entrances, and walkways.
- c. Interior distribution systems include service entrance and distribution equipment, TVSS, dry type transformers, wiring devices, raceways, conductors, interior lighting systems, emergency power systems, lightning protection systems, hazardous locations, housing distribution, and systems furniture.
- d. Communications and security includes telecommunications systems, television systems, electronic security systems (ESS), and intercommunication systems.

3-16.1 Power

Provide separate dedicated panel boards to serve each separate user area.

Shops and Maintenance Administration

Serve shop spaces by distinct panels dedicated to shop and equipment loads only. Do not supply office spaces from shop circuits or panels. Except as specifically noted otherwise, feed loads located in each Shop space must be from panel boards located within the Shop space.

3-16.2 Emergency Power

Coordinate and provide emergency power as dictated by the mission.

3-16.3 Lighting

Design in accordance with UFC 3-530-01, *Design: Interior and Exterior Lighting and Controls*.

3-16.3.1 Interior Lighting

Refer to UFC 1-200-01, *General Building Requirements* and UFC 3-530-01, *Design: Interior, Exterior Lighting and Controls* for guidance on system selection. Lighting requirements may be minimized by providing natural daylighting and specialized lighting on the materials handling equipment, as required by the user.

3-16.3.2 Exterior Lighting

Provide dock lights every 25 feet (8 m) of rail dock and for each truck dock for illumination of rail car, truck, or trailer interior.

Provide lighting at parking lots, maneuvering areas, outside storage, and, where required, fence lighting.

3-16.4 Receptacles

Locate convenience outlets in accordance with UFC 3-520-01, *Interior Electrical Systems*. There must be a minimum of one receptacle on every wall.

3-16.5 Battery Chargers

Provide circuits to power battery chargers for battery-operated materials handling equipment.

3-16.6 Lightning Protection

Provide lightning protection in accordance with UFC 3-575-01 *Lightning and Static Electricity Protection Systems*.

3-17 CIVIL

Refer to UFC 1-200-01, *General Building Requirements* and UFC 3-201-01, *Civil Engineering* for physical security, antiterrorism, standoff distances, setbacks, Low Impact Design (LID), storm drainage, geotechnical site investigation, vehicular and pedestrian circulation, and other site related requirements.

3-17.1 Siting

When siting the Warehouse, place emphasis on operation, function, energy efficiency and safety. Comply with the requirements of UFC 1-200-01, *General Building Requirements*.

3-17.1.1 Site Organization

Provide efficient access to the delivery drive aisle(s). Develop a sense of order, arrival, orientation, and community in planning the site. Arrange the placement of structures in relationship to one another to create outdoor spaces for use as passive or active recreation areas. Organize the site using functional zones and the appropriate relationship of functions. Other factors to consider include topography, vegetative cover, existing construction, weather elements, wind direction, soil conditions, flood

hazards, natural and man-made obstructions, adjacent land use and accessibility of utilities. Vehicular parking, pedestrian access and traffic flow must also be given careful consideration.

Truck traffic must be separated from other vehicular traffic. Truck delivery routes must be planned so drivers are not backing up to the dock on their blind side. Truck arrival route must be counterclockwise to the facility.

3-17.1.2 Finished Floor Elevation

Establishing the finished floor elevation of the project is one of the most important aspects of site planning. The finished floor elevation affects grading, cut and fill, and visual impact of the facility and interior and exterior transitions. In addition, the finished floor elevation has a significant impact on the landscape architect's ability to effectively introduce plant materials into the new environment. When the approach is to "level the site" without sensitivity to other demands, the results lack visual interest. Closely combine efforts of the landscape architect, architect, and civil engineer to achieve the most optimum design results. Provide the facility's minimum finished floor elevation and the mechanical/electrical equipment pad elevations in accordance with UFC 3-201-01, *Civil Engineering*.

3-17.2 Utilities

Design utilities in accordance with UFC 3-201-01, *Civil Engineering*.

3-17.3 Utility Metering

Provide metering in accordance with UFC 1-200-02, *High Performance and Sustainable Building Requirements*.

3-18 SUSTAINABLE DESIGN

Refer to UFC 1-200-01, General Building Requirements and UFC 1-200-02, *High Performance and Sustainable Building Requirements* for minimum requirements and guidance to achieve high performance and sustainable facilities.

CHAPTER 4 HAZARDOUS MATERIALS STORAGE GENERAL DESIGN CRITERIA

4-1 GENERAL

Requirements from Chapter 1 – 3 of this UFC must be applicable to Hazardous Materials Storage Facilities except as modified by Chapter 4.

Reference UFC 1-200-01; *General Building Requirements for Use and Occupancy requirements.*

4-2 HAZARDOUS MATERIALS STORAGE

Space justified for hazardous materials storage must be considered a portion of the total space allowed for the facility type. Use DoD Real Property Classification System (RPCS); Category Codes 441-10 through 441-40 facility types. Such space must not exceed 5 percent of the total space unless justified. Hazardous materials storage must be designed and constructed in accordance with the standard references listed in the paragraph in Chapter 4 entitled, "General" for storage of materials classified as hazardous to health, environment, and property, i.e., flammables, acids, caustics, oxidizers, water reactives, or others considered hazardous by the following Code of Federal Regulations (CFR's): Title 29 CFR 1910, *Occupational Safety and Health Standards*; 40CFR - *Protection of Environment*, 49CFR - *Transportation* - parts 171-177, *Hazardous Materials Safety*; and FED-STD-313, *Material Safety Data, Transportation Data, and Disposal Data for Hazardous Materials Furnished to Government Activities.*

4-2.1 Compliance Standards

Comply with NFPA 400, Hazardous Materials Code and the following federal, industry, and association standards.

4-2.1.1 Federal Regulations

Comply with requirements of 29CFR - *Occupational Safety and Health Standards*, 40CFR - *Protection of Environment*, 49CFR - *Transportation*, Army Pamphlet DA PAM 710-7, *Hazardous Materials Management Program*, DoD 4140.1-R, *Supply Chain Material Management Regulation*, and Army TM 38-400/ Navy NAVSUP PUB 572/ Air Force AFJMAN 23-210/ Marine Corps MCO 4450-14/ Defense Logistics Agency DLAM 4145.12, *Joint Services Manual (JSM) for Storage and Materials Handling.*

4-2.2 Hazardous Materials Storage

Hazardous materials storage facilities must be designed and constructed to offer protection against the physical, health, or environmental hazards presented by the material. Storage and handling of hazardous materials must be confined to buildings or parts of buildings meeting the requirements of this section.

4-2.3 Design Criteria

Facility design and layout must take into consideration the incompatibility of hazardous materials and hazardous materials groups. Individual facility design and layout must be based upon the specific types and categories of hazardous materials that are to be handled and stored.

4-2.3.1 Building Spacing

Provide a buffer zone between the facility and the nearest inhabited area, stream, or body of water in accordance with UFC 1-200-01, *General Building Design Requirements* and UFC 3-600-01, *Fire Protection Engineering for Facilities*.

4-2.3.2 Docking Facilities

Dock areas in hazardous materials facilities must provide a manually operated valve in the outside drain trench to prevent spills from entering the storm sewer system. The drain must discharge into a sump sized to accommodate the expected quantity of discharge.

4-2.4 Storage Requirements

Accommodate the following storage requirements in the design of hazardous materials storage areas within other warehouse types listed in the paragraph entitled "Types of Storage Facilities".

- a. The storage area must be designed to prevent surface or groundwater contamination in the event of a spill or leak, and to capture completely each class of material individually.
- b. In acid or caustic liquid storage, a man-up type vehicle **MUST** be used. Otherwise, the liquids must be stored on the floor to keep the loads below the operator's eye level.
- c. Spill Containment must be provided as required by the paragraph entitled "Segregation of Materials".

4-2.5 Material Handling Equipment

Electrically powered materials handling equipment is the only type of powered material handling equipment rated for use in hazardous materials storage areas. Use vehicles which have all electrical equipment completely enclosed in hazardous materials warehouses. Type EX vehicles, which have all fittings and equipment, designed, constructed, and assembled for use in atmospheres containing flammable vapors, dust; and fibers, may be required for unique chemicals or applications. Verify the need for any additional requirements which may be imposed by special storage conditions.

4-3 SEGREGATION OF MATERIALS

Provide segregated storage areas for materials having incompatible hazardous characteristics.

4-3.1 Categories of Materials

Normally, six categories of hazardous materials must be accommodated and provided segregated storage areas within a hazardous materials storage facility. Other categories may be encountered in some designs and require additional segregated storage areas. These materials as defined by OSHA consist of the following:

4-3.1.1 Flammable and Combustible Liquids

Liquids are defined by National Fire Protection Association (NFPA) *Flammable and Combustible Liquids Code*, NFPA 30 as any material having a fluidity greater than 300 penetration asphalt, when tested in accordance with the *Standard Test Method for Penetration of Bituminous Materials*, ASTM D5/D5M.

4-3.1.1.1 Flammable

Flammable liquids have a flash point below 100°F (38°C) and a vapor pressure not exceeding 40 psi absolute (275 kPa) at 100°F (38°C). These liquids are also classified as Class I liquids.

4-3.1.1.2 Combustible

Combustible liquids have a flash point of 100°F (38°C) or higher. Combustible liquids are further classified as Class II for flash points at or above 100°F (38°C) and below 140°F (60°C), and Class III for flash points at or above 140°F (60°C).

4-3.1.2 Acids

Acids and acid mists and gases react with arsenides, borides, carbides, cyanides, fluorides, phosphides, selenides, silicides, sulfides, sulfites, and tellurides to generate toxic fumes. They also liberate hydrogen upon contact with metals and hydrides.

4-3.1.3 Oxidizers

Oxidizing materials are those chemicals which will decompose readily under certain conditions to yield oxygen. They may cause a fire in contact with combustible materials, may react violently with water, and when involved in a fire may react violently. Typical oxidizers include: organic and inorganic peroxides, permanganates, chlorates, perchlorates, persulfates, organic and inorganic nitrates, bromates, perbromates, chromates, and dichromates.

4-3.1.4 Poisons

Poisons are materials that cause death by systemic poisoning rather than by corrosive destruction of tissue. Under adverse conditions, such as a leak, spill, fire, or poor

ventilation, a common chemical or compound (e.g., ammonia) may be considered poisonous.

4-3.1.5 Water Reactive Materials

These materials react with water, steam, or water solutions to produce flammable gases, toxic gases, explosive gases, or heat. Flammable gas producers include calcium, cobalt, hydrides, lithium, potassium, rubidium alloys, and sodium. Explosive gas producers include arsenides, borides, carbides, nitrides, phosphides, selenides, silicides, sulfides, and tellurides. Heat producers include acid anhydrides, concentrated acids, and concentrated alkalis. It is essential that no water-based fire extinguishment system be used in storage areas designated for water reactive materials. \1\1/

4-3.1.6 Caustics

Caustics (alkalis) may liberate hydrogen upon contact with aluminum. They are not compatible with acids and must be segregated from acids for safe and efficient operations.

4-3.1.7 Organic Peroxides

Organic peroxides must be stored in a segregated storage area, separated from all other materials.

4-3.2 Segregation Requirements

Provide for segregated storage of hazardous materials as required by Army Pamphlet DA PAM 710-7, *Hazardous Material Management Program*, DoD 4140.1-R, *Supply Chain Material Management Regulation*, and Army TM 38-400/ Navy NAVSUP PUB 572/ Air Force AFJMAN 23-210/ Marine Corps MCO 4450-14/ Defense Logistics Agency DLAM 4145.12, *Joint Services Manual (JSM) for Storage and Materials Handling*. Typical segregated storage block layouts are shown in figure 4-1. Comply with the following segregation requirements:

- a. Acids must be isolated from other materials, including chemicals within the corrosives area.
- b. Flammable liquids must be isolated from acids and oxidizers.
- c. Organic acids must be isolated from oxidizers.
- d. Oxidizers must be isolated from all flammable and combustible liquids.

Figure 4-1 Hazardous Materials Storage Segregation Layouts

Plan Views

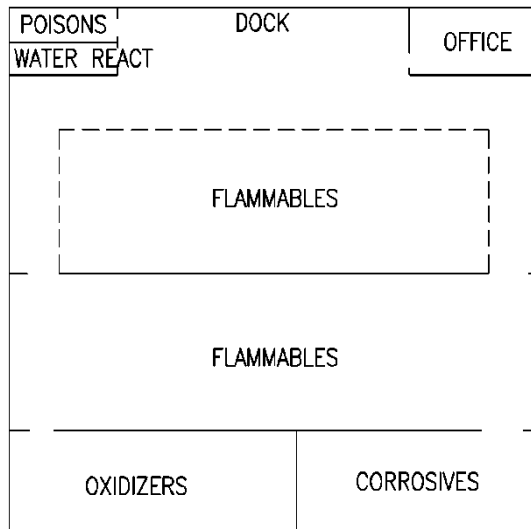
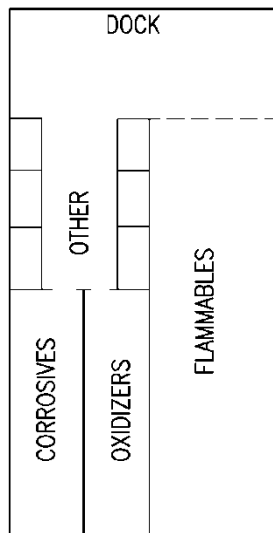
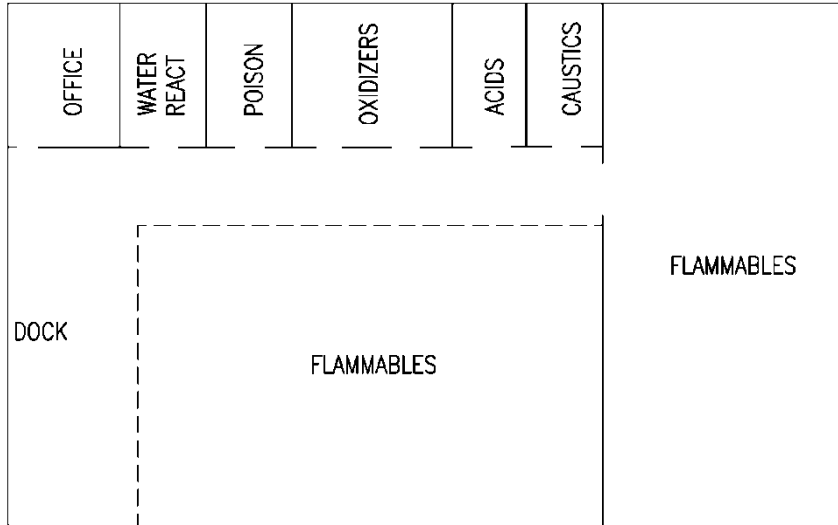

4-3.2.1 Compressed Gas Cylinders

Compressed gas cylinders of flammable and nonflammable gases, and gases classified as oxidizers, must be stored in sheds and neither in hazardous materials warehouses or hazardous materials storage areas within a general storage warehouse. Small cylinders in boxes, which are an integral part of other equipment, may be stored in hazardous materials warehouses, if properly segregated from incompatible materials.

4-3.2.2 Drummed Petroleum/Oil/Lubricant (POL)

Drummed POL products with a flash point of more than 100°F (38°C) must be stored in shed or open storage facilities with sealed pavements and berms/dikes to contain spills. Outside storage for drummed POL may be used, provided the drums are of corrosion resistant material or are hot-dipped galvanized for corrosion protection.

4-3.2.3 Other Materials

Dry corrosive materials, Other Regulated Materials, and radioactive materials having no other hazard, may be stored in general purpose warehouses. All other radioactive materials must be stored in a designated, separate area in accordance with DLAI 4145.8 / NAVSUPINST 4000.34C / AFJI 23-504 / MCO P4400.105E, *Radioactive Commodities in the DOD Supply Systems*.

4-3.3 Combined Shed Storage

When a hazardous materials warehouse is combined with shed storage, provide a 4-hour fire wall to separate the two storage areas. Shed and warehouse floors must be at the same elevation, with spill containment trenches or drains at fire doors. Access to the shed must be from the dock area of the warehouse, NOT from within a storage area.

4-4 SPILL CONTAINMENT AND CONTROL

Means of providing containment and removal must be provided in the event of spills. Refer to 29 CFR 1910.106 for additional information.

4-4.1 Exterior Containment

Exterior containment areas must be graded in a manner to divert possible spills away from buildings or other exposures or be surrounded by a curb at least 6 inches high, see paragraph in Chapter 4 entitled "Dikes". When curbs are used, provisions must be made for draining of accumulations of ground or rain water or spills of flammable liquids. Drains are to terminate at a safe location and must be accessible to operation under fire conditions.

4-4.2 Interior Containment

Inside storage rooms must be constructed to meet the required fire-resistive rating for their use. Such construction must comply with the test specifications set forth in Standard Methods of Fire Tests of Building Construction and Materials, NFPA 251. Openings to other rooms or buildings are to be provided with noncombustible liquid-tight raised sills or ramps at least 4 inches in height or the floor in the storage area must be at least 4 inches below the surrounding floor. Openings must be provided with approved self-closing fire doors. The room must be liquid-tight where the walls join the floor. A permissible alternate to the sill or ramp is an open-grated trench inside of the room that drains to a safe location, see paragraph in Chapter 4 entitled "Floor Trenches and Capture System". Where other portions of the building or other properties are

exposed, windows must be protected as set forth in the Standard for Fire Doors and Windows, NFPA No. 80.

4-4.3 Dikes

Dikes must be used for containment of spills for gasoline and/or diesel fork truck refueling stations and commodities stored or handled outside of buildings. In accordance with National Fire Protection Association (NFPA) *Flammable and Combustible Liquids Code*, NFPA 30, their volume must be not less than 110% of liquid that can be released from a fork truck or the largest storage container within the diked area or a 10% minimum of all materials to be stored in the area, whichever is greater.

4-4.4 Floor Trenches and Capture Systems

Where a continuous floor trench with grating is used in areas of hazardous materials storage for the capture and control of hazardous chemical spills see figure 4-2. All spill containment systems must provide separate containment as described in the paragraph in Chapter 4 entitled, "Containment". Secure grate frame support channels to concrete floors. Grate design must provide for the ability to latch the removable grate sections at aisle crossings and cargo doors to ensure that grates will remain firmly in place when material handling equipment moves over them. The cross section of the grate frame members must be "Z-", rather than "L-", shaped so that two legs of the "Z" form a pocket for grates and the third leg is in the horizontal plane at floor level, as illustrated in figure 4-2. This protects the edges of concrete around grate frames from impact damage from the wheels of materials handling equipment.

Where a trench passes in front of a personnel door use \1\concrete cover or solid concrete plates sufficient /1/ to prevent a fire in the trench from blocking the exit door.

Figure 4-2 Spill Capture/Containment System

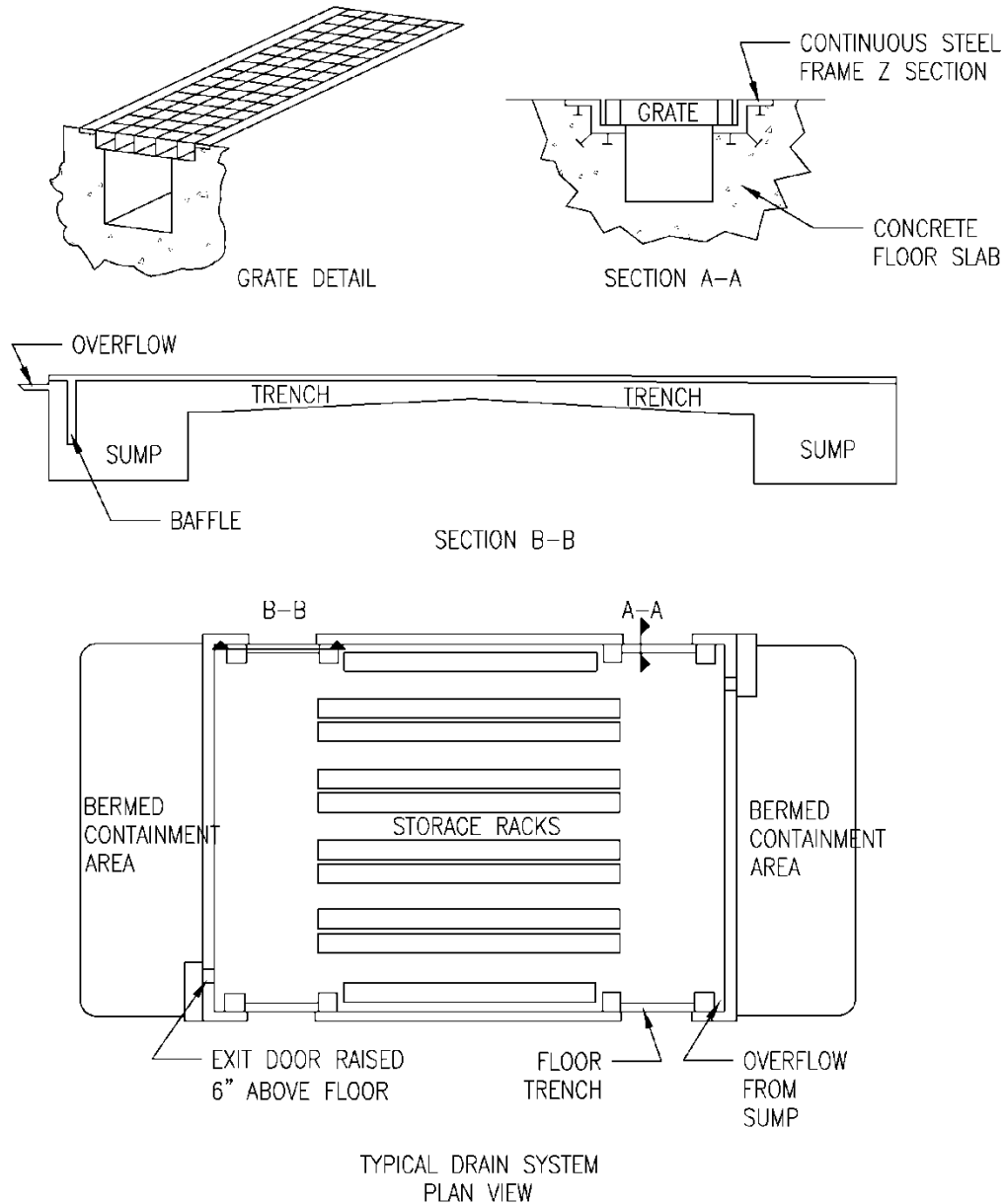

4-4.4.1 Electronic Guide Wire Crossing

When floor-buried electronic guide wire is used to guide material handling vehicles across trench grates that cross aisles or are at cargo doors, use a nonmagnetic grate section extending at least 6 inches (150 mm) on each side of the wire path so that the magnetic field of the guide wire is not distorted by passing the wire through a ferrous or magnetic grate. Alternatively, use slotted drains and pass the guide wire under the drains and shield the guide wire when passing through ferrous or magnetic grates or drains. Figure 4-3 illustrates typical crossing methods.

Figure 4-3 Electronic Guide Wire Crossing

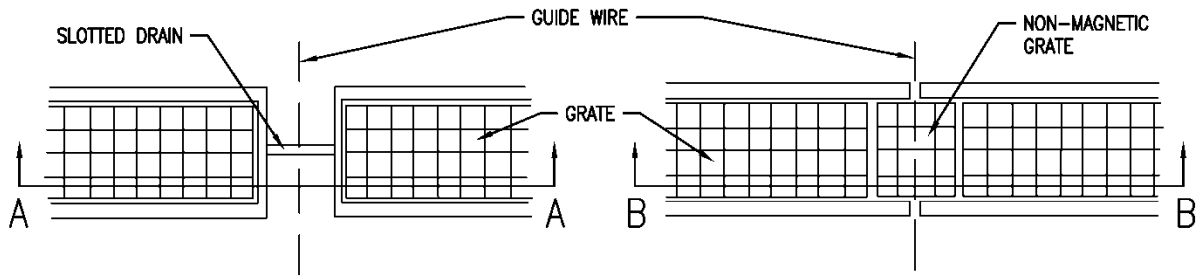

PLAN VIEW

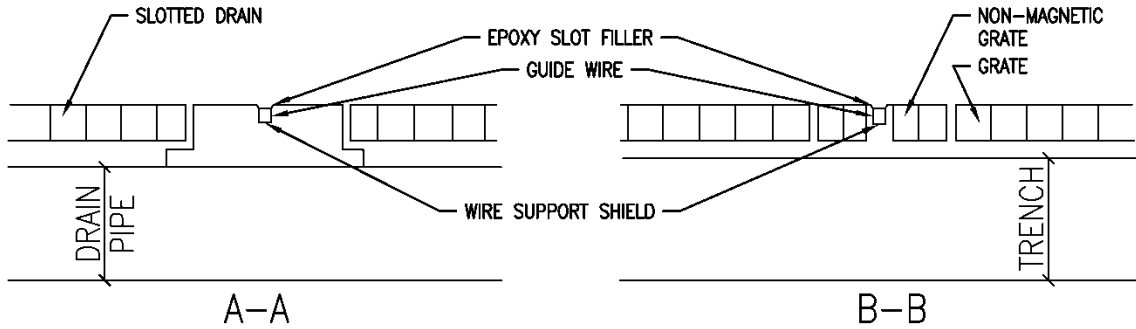

SECTION VIEW

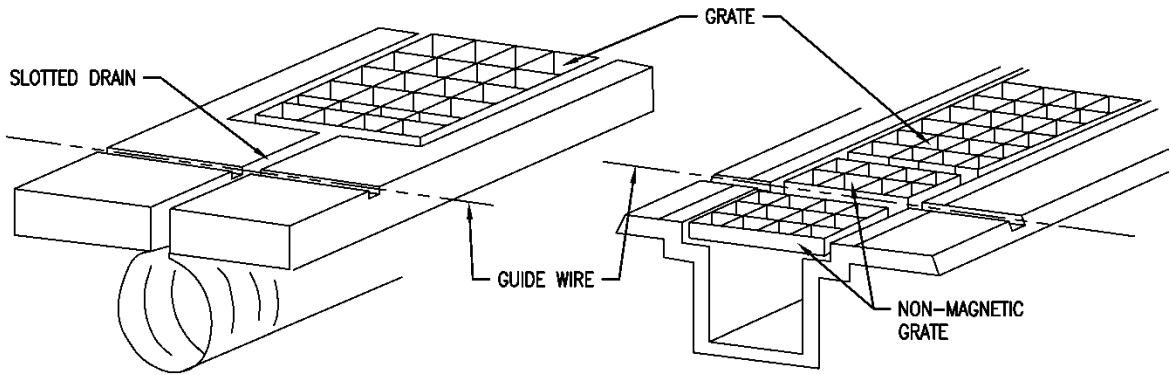

SLOTTED DRAIN
CROSSING

GRATE/ TRENCH
CROSSING

4-4.5 Recessed Floor

When required for specific design or containment needs, interior storage floor surfaces may be recessed 6 inches (150 mm) below the level of adjoining dock, office, and support areas to prevent the flow of spilled hazardous liquids into these areas. Vehicle access ramps must be provided at all doorways into such areas. The use of this method is discouraged due to operational inefficiencies and the additional space requirements caused by the ramps.

4-4.6 Containment

Use grate-covered interior 350 gallon (1323 l) sumps in conjunction with the trench system to provide spill or leakage containment for the lesser of 1,000 gallons (3785 l) or 10 percent of the total free flowing liquid volume of all containers stored in each segregated area. Provide a containment capacity of 1,000 gallons (3785 l) at the truck apron adjacent to the shipping and receiving area. Include a controlled flow system to prevent spilled or leaking materials from entering the environment.

4-4.7 Drainage

Install pallet racks and associated mechanical vehicle guidance systems so as to permit the unimpeded flow of spilled liquids to collecting trenches. Maintain floor flatness requirements. Floor drains connecting to the sanitary sewer are not permitted in storage areas of hazardous materials.

APPENDIX A REFERENCES

AMERICAN ARCHITECTURAL MANUFACTURERS ASSOCIATION (AAMA)

<http://www.aamanet.org/>

AAMA WSG-11, *Window Selection Guide*

AMERICA CONCRETE INSTITUTE (ACI)

<http://www.concrete.org/>

ACI 302.1R-04, *Guide for Concrete Floor and Slab Construction*

AMERICAN NATIONAL STANDARDS INSTITUTE

<http://www.ansi.org/>

ANSI MH27.1, *Specifications for Patented Track Underhung Cranes and Monorail Systems*

ANSI B11.19, *Performance Requirements for Safeguarding*

ANSI/BHMA - A156.13, *Mortise Locks and Latches*

ANSI/BHMA - A156.2, *Bored and Preassembled Locks and Latches*

AMERICAN SOCIETY FOR TESTING AND MATERIALS

<http://www.astm.org/>

ASTM D5/D5M, *Standard Test Method for Penetration of Bituminous Materials*

CODE OF FEDERAL REGULATIONS (CFR)

Title 29 CFR 1910, *Occupational Safety and Health Standards*

Title 29 CFR 1910.22, *General Requirements*

Title 29 CFR 1910.23, *Guarding Floor and Wall Openings and Holes*

Title 29 CFR 1910.144, *Safety Color Code for Marking Physical Hazards*

Title 29 CFR 1910.179(j), *Inspections*

Title 29 CFR 1910.179(k), *Testing*

Title 29 Code of Federal Regulations (CFR) Part 1910, *Occupational Safety and Health Standards*

Title 40 CFR - *Protection of Environment*

Title 49 CFR *Transportation*

CRANE MANUFACTURING ASSOCIATION OF AMERICA (CMAA)

<http://www.mhi.org/cmaa>

CMAA Specification 70, *Top Running Bridge and Gantry Type Multiple Girder Electric Overhead Traveling Cranes*

CMAA Specification 74, *Top Running and Under Running Single Girder Electric Overhead Cranes Utilizing Under Running Trolley Hoist*

DEPARTMENT OF THE AIR FORCE

Air Force Instruction (AFI) 91-203, *Air Force Consolidated Occupational Safety Instruction*

DEPARTMENT OF THE ARMY

DA PAM 710-7, *Hazardous Material Management Program*

TM 5-301-2, *Army Facilities Components System Planning (Tropical)*

DEPARTMENT OF DEFENSE (DOD)

DOD 4140.1-R, *DoD Supply Chain Material Management Regulation*,
<http://www.dtic.mil/whs/directives/>

DoD Directive 5200.8-R, *Security of DoD Installations and Resources*,
<http://www.dtic.mil/whs/directives/>

DoD Instruction 6055.1, *DoD Safety and Occupational Health (SOH) Program*,
<http://www.dtic.mil/whs/directives/>

FED-STD-313, *Material Safety Data, Transportation Data, and Disposal Data for Hazardous Materials Furnished to Government Activities*,
<http://www.wbdg.org/ccb/FEDMIL/fedstd313d.pdf>

MIL-HDBK-1013/1A, *Design Guidelines for Physical Security of Facilities*,
http://www.wbdg.org/ccb/NAVFAC/DMMHNAV/1013_1a.pdf

MIL-STD-882, *System Safety Program Requirements*,
http://quicksearch.dla.mil/qsDocDetails.aspx?ident_number=36027

UNIFIED SERVICE BRANCH CRITERIA

Army TM 38-400/ Navy NAVSUP PUB 572/ Air Force AFJMAN 23-210/ Marine Corps MCO 4450-14/ Defense Logistics Agency DLAM 4145.12, *Joint Services Manual (JSM) for Storage and Materials Handling*

Armed Forces Pest Management Board Technical Guide No. 17, *Military Handbook – Design of Pest Management Facilities.*

<http://www.afpmb.org/sites/default/files/pubs/techguides/tg17.pdf>

DLAI 4145.8 / NAVSUPINST 4000.34C / AFJI 23-504 / MCO P4400.105E, *Radioactive Commodities in the DOD Supply Systems,*

<http://www.dla.mil/issuances/Documents/i4145.8.pdf>

UNIFIED FACILITIES CRITERIA

<https://www.wbdg.org/dod/ufc>.

UFC 1-200-01, *General Building Requirements*

UFC 1-200-02, *High Performance and Sustainable Building Requirements*

UFC 2-000-05N (P-80), *Facilities Planning Criteria for Navy/Marine Corps Shore Installations*

UFC 3-101-01, *Architecture*

UFC 3-110-03, *Roofing*

UFC 3-120-01, *Design: Sign Standards*

UFC 3-120-10, *Interior Design*

UFC 3-190-06, *Protective Coatings and Paints*

UFC 3-201-01, *Civil Engineering*

UFC 3-220-01, *Geotechnical Engineering*

UFC 3-301-01, *Structural Engineering*

UFC 3-310-04, *Seismic Design for Buildings*

UFC Series 3-400, *Mechanical*

UFC 3-410-01, *Heating, Ventilating, and Air Conditioning Systems*

UFC 3-410-04N, *Industrial Ventilation*

UFC 3-420-01, *Plumbing Systems*

UFC 3-450-01, *Noise and Vibration Control*

UFC 3-460-01, *Design: Petroleum Fuel Facilities*

UFC 3-501-01, *Electrical Engineering*

UFC 3-520-01, *Interior Electrical Systems*

UFC 3-530-01, *Design: Interior, Exterior Lighting and Controls*

UFC 3-575-01, *Lightning and Static Electricity Protection Systems*

UFC 3-580-01 *Telecommunications Building Cabling Systems Planning and Design*

UFC 3-580-10 *Navy and Marine Corps Intranet (NMCI) Standard Construction Practices*

UFC 3-600-01, *Fire Protection Engineering for Facilities*

UFC 4-010-01, *DoD Minimum Antiterrorism Standards for Buildings*

UNIFIED FACILITIES GUIDE SPECIFICATIONS

UFGS 01 35 26, *Governmental Safety Requirements*

UFGS 11 41 11, *Refrigerated and Frozen Food Storage Equipment*

UFGS 41 22 13.13, *Bridge Cranes*

UFGS 41 22 13.15, *Bridge Cranes, Overhead Electric, Under Running*

INTERNATIONAL CODE COUNCIL

<http://www.iccsafe.org>

International Building Code (IBC)

MASTER PAINTER INSTITUTE

<http://www.paintinfo.com/>

MPI 212, *Floor Coating, Thin Film, for Aircraft Maintenance Facilities*

NATIONAL FIRE PROTECTION ASSOCIATION

<http://www.nfpa.org/>

NFPA 101, *Life Safety Code*

NFPA 13, *Standard for the Installation of Sprinkler Systems*

NFPA 30, *Flammable and Combustible Liquids Code*

NFPA 72, *National Fire Alarm and Signaling Code* 11

NFPA 400, *Hazardous Materials Code* 11

NFPA 430, *Code for the Storage of Liquid and Solid Oxidizers*

NAVAL FACILITIES ENGINEERING COMMAND

Interim Technical Design Guidance ITG FY05-02, *NAVFAC Humid Area HVAC Design Criteria*, http://www.wbdg.org/ccb/NAVFAC/INTCRIT/fy05_02.pdf

Navy Crane Center Instruction 11450.2, *Design of Navy Shore Weight Handling Equipment*,
https://portal.navy.mil/portal/page/portal/docs/doc_store_pub/navcranecen%20instruction%2011450.2.pdf

STEEL DOOR INSTITUTE

<http://www.steeldoor.org/>

ANSI/SDI A250.8, *Standard Steel Doors and Frames*

UNDERWRITER'S LABORATORY

<http://www.ul.com>

UL325, *Door, Drapery, Gate, Louver, and Window Operators and Systems*

This Page Intentionally Left Blank

APPENDIX B BEST PRACTICES

B-1 GENERAL

This appendix identifies background information and practices for accomplishing design and engineering services. The Designer of Record (DOR) is expected to review and interpret this guidance and apply the information according to the needs of the project. If a Best Practices document has guidelines or requirements that differ from the UFGS or UFC, the UFGS and the UFC must prevail. If a Best Practices document has guidelines or requirements that are not discussed in the UFGS or UFC, the DOR must submit a list of the guidelines or requirements being used for the project with sufficient documentation to the Government Project Manager for review and approval prior to completing design.

B-2 WHOLE BUILDING DESIGN GUIDE

The Whole Building Design Guide (WWW.WBDG.ORG) provides additional information and discussion on practice and facility design, including a holistic approach to integrated design of facilities.

The WBDG provides access to Construction Criteria Base (CCB) criteria, standards and codes for the DoD Military Departments, National Aeronautics and Space Administration (NASA), and others. These include, UFC, UFGS, Performance Technical Specifications (PTS), design manuals, and specifications. For approved Government employees, it also provides access to non-government standards.

B-3 FACILITY DESIGN

Comply with UFC (Latest Version), FC, and other related criteria as noted in UFC 1-200-01, General Building Requirements under the heading “UNIFIED FACILITY CRITERIA”.

This Page Intentionally Left Blank

APPENDIX C GLOSSARY

ABA	Architectural Barriers Act
ADAAG	Americans with Disabilities Act Accessibility Guidelines
AFCEE	Air Force Center for Engineering and the Environment
BIA	Bilateral Infrastructure Agreement
CFR	Code of Federal Regulations
DoD	Department of Defense
HQUSACE	Headquarters, U.S. Army Corps of Engineers
HNFA	Host Nation Funded Construction Agreements
IBC	International Building Code
MPI	Master Painter's Institute
NAVFAC	Naval Facilities Engineering Command
NFPA	National Fire Protection Association
SOFA	Status of Forces Agreements
UFC	Unified Facilities Criteria
U.S.	United States