

UNIFIED FACILITIES CRITERIA (UFC)

ARMY CONTINUING EDUCATION SYSTEM CENTERS



APPROVED FOR PUBLIC RELEASE; DISTRIBUTION UNLIMITED

UNIFIED FACILITIES CRITERIA (UFC)

ARMY CONTINUING EDUCATION SYSTEM CENTERS

Any copyrighted material included in this UFC is identified at its point of use. Use of the copyrighted material apart from this UFC must have the permission of the copyright holder.

U.S. ARMY CORPS OF ENGINEERS (Preparing Activity)

NAVAL FACILITIES ENGINEERING COMMAND

AIR FORCE CIVIL ENGINEER SUPPORT AGENCY

Record of Changes (changes are indicated by \1\ ... /1/)

Change No.	Date	Location

This UFC supersedes DG 1110-3-112, dated May 1979. The format of this UFC does not conform to UFC 1-300-01; however, the format will be adjusted to conform at the next revision. The body of this UFC is the previous DG 1110-3-112, dated May 1979.

FOREWORD

\1\

The Unified Facilities Criteria (UFC) system is prescribed by MIL-STD 3007 and provides planning, design, construction, sustainment, restoration, and modernization criteria, and applies to the Military Departments, the Defense Agencies, and the DoD Field Activities in accordance with [USD\(AT&L\) Memorandum](#) dated 29 May 2002. UFC will be used for all DoD projects and work for other customers where appropriate. All construction outside of the United States is also governed by Status of forces Agreements (SOFA), Host Nation Funded Construction Agreements (HNFA), and in some instances, Bilateral Infrastructure Agreements (BIA.) Therefore, the acquisition team must ensure compliance with the more stringent of the UFC, the SOFA, the HNFA, and the BIA, as applicable.

UFC are living documents and will be periodically reviewed, updated, and made available to users as part of the Services' responsibility for providing technical criteria for military construction. Headquarters, U.S. Army Corps of Engineers (HQUSACE), Naval Facilities Engineering Command (NAVFAC), and Air Force Civil Engineer Support Agency (AFCEA) are responsible for administration of the UFC system. Defense agencies should contact the preparing service for document interpretation and improvements. Technical content of UFC is the responsibility of the cognizant DoD working group. Recommended changes with supporting rationale should be sent to the respective service proponent office by the following electronic form: [Criteria Change Request \(CCR\)](#). The form is also accessible from the Internet sites listed below.

UFC are effective upon issuance and are distributed only in electronic media from the following source:

- Whole Building Design Guide web site <http://dod.wbdg.org/>.

Hard copies of UFC printed from electronic media should be checked against the current electronic version prior to use to ensure that they are current.

AUTHORIZED BY:

DONALD L. BASHAM, P.E.
Chief, Engineering and Construction
U.S. Army Corps of Engineers

DR. JAMES W. WRIGHT, P.E.
Chief Engineer
Naval Facilities Engineering Command

KATHLEEN I. FERGUSON, P.E.
The Deputy Civil Engineer
DCS/Installations & Logistics
Department of the Air Force

Dr. GET W. MOY, P.E.
Director, Installations Requirements and
Management
Office of the Deputy Under Secretary of Defense
(Installations and Environment)

CEMP Design Guide 1110-3-112	Department of the Army U.S. Army Corps of Engineers Washington, DC 20314-1000	DG 1110-3-112 May 1979
	ARMY CONTINUING EDUCATION SYSTEM CENTERS	
	Distribution Restriction Statement Approved for public release; distribution is unlimited.	

INACTIVE

DG 1110-3-112

**DESIGN GUIDE
ARMY CONTINUING EDUCATION SYSTEM
CENTERS**

Department of the Army
Office of the Chief of Engineers
Military Programs Directorate
Engineering Division
Washington, D.C. 20314

May 1979

Limited Distribution

CHAPTER 1—INTRODUCTION

1-1 PURPOSE	1-1
a. Planning Guidance	1-1
b. Design Guidance	1-1
1-2 SCOPE	1-1
a. Guide Limitation	1-1
b. Presentation of Guidance	1-1
c. Example Designs	1-1
1-3 REFERENCES	1-1
a. ACES Program Functions	1-1
b. DOD Construction Criteria	1-2
c. Project Planning and Design	1-2
d. Completion Records	1-2
1-4 EMPHASIS	1-2
a. Design Quality	1-2
b. Design Services	1-2
c. User Information	1-2
1-5 RESPONSIBILITIES	1-2
a. Installation	1-2
b. Design Agency	1-3
1-6 DEFINITIONS	1-3
a. Net Space	1-3
b. Gross Space	1-4
c. Functional Requirements	1-4
d. Space Allocation Criteria	1-4
e. Design Criteria	1-4
f. Space Organization Principles	1-4

CHAPTER 2—PLANNING GUIDELINES

2-1 GENERAL	2-1
2-2 ACES: THE PLANNING BASE	2-1
a. Instructional Programs	2-1
b. Other ACE Program Functions	2-2
c. Students	2-2
d. Staff	2-3
e. Instructional Aids	2-3

	Page
2-3 PLANNING REQUISITES AND DOCUMENTATION	2-3
a. Project Development Brochure.	2-4
b. DD Form 1391	2-4
2-4 ANALYZING THE SITE	2-4
a. Approved General Site Plan...	2-4
b. Preliminary Site Layout	2-5
c. Estimating Site Costs	2-5
2-5 DEVELOPING THE BUILDING PROGRAM	2-5
a. Maximum Space Allowances.	2-5
b. Actual Space Needs: Developing the Building Program	2-7
c. Occupant Capacity	2-9
d. Example Determinations of Needs and Capacity	2-10
e. Estimating Building Costs	2-10
2-6 RELATED FURNISHINGS AND EQUIPMENT	2-11
a. Coordinating Requirements	2-11
b. Estimating Furnishings and Equipment Costs	2-12
 CHAPTER 3 – GENERAL DESIGN CONSIDERATIONS	
3-1 GENERAL	3-1
a. Barrier Free Design	3-1
b. Energy Conservation	3-1
c. Flexibility	3-1
d. Life Cycle Enhancement	3-1
3-2 DESIGN REQUISITES AND DOCUMENTATION	3-1
a. Concept Design	3-1
b. Final Design	3-2
3-3 SITE DEVELOPMENT	3-2
a. Building-Site Relationship	3-2
b. Vehicular & Pedestrian System	3-2
c. Landscaping and Signage Plan	3-2
3-4 BUILDING DESIGN	3-5
a. Architectural Image	3-5
b. Functional Layout	3-7
c. Structure and Environmental Support	3-9
d. Interior Detailing	3-18

Page

3-5 RELATED FURNISHINGS AND EQUIPMENT 3-23

- a. Selection Factors 3-23
- b. Procurement Support 3-23
- c. Delivery and Placement 3-23

3-6 PROVISIONS FOR USER INFORMATION 3-24

- a. Special Considerations 3-24
- b. Site Design 3-24
- c. Building Design 3-24
- d. Equipment and Furniture 3-25

CHAPTER 4 – INDIVIDUAL SPACE CRITERIA

4-1 GENERAL 4-1

4-2 STAFF SPACES 4-1

- a. Director's Office 4-1
- b. Administrator Offices 4-2
- c. Information/Registration/Clerk/Typist Space 4-3
- d. Counselor Offices 4-5

4-3 ACADEMIC SPACES 4-6

- a. Classroom 4-6
- b. Lecture Room 4-7
- c. Seminar Room 4-8
- d. MOS Library 4-9
- e. Self-Paced Instruction 4-10
- f. Language Laboratory 4-11
- g. Science Laboratory 4-12
- h. Testing Room 4-13
- i. Rehearsal/Recording Studio 4-14

4-4 VOCATIONAL TRAINING SPACES 4-15

- a. Heating/Refrigeration/Air Conditioning Shop 4-16
- b. Construction Electrician Shop 4-16
- c. Communications/Industrial Electronics Shop 4-19
- d. Masonry Shop 4-21
- e. Carpentry Shop 4-23
- f. Plumbing Shop 4-25
- g. Diesel Mechanics Shop 4-27
- h. Auto Mechanics Shop 4-29
- i. Welding Shop 4-31
- j. Auto Body Repair Shop 4-33
- k. Small Engine Repair Shop 4-35

TABLE OF CONTENTS

DG 1110-3-112 May 1979

	Page
4-5 SUPPORT SPACES	4-37
a. Staff Lounge	4-37
b. Student Lounge	4-38
c. Vending Area	4-39
d. Training Aids Preparation.. ..	4-40
e. Toilets	4-41
f. Receiving and General Storage.. ..	4-43
g. Janitor Closet	4-44
4-6 SUMMARY OF ENVIRONMENTAL CRITERIA	4-45
 CHAPTER 5 – SPACE ORGANIZATION	
5-1 GENERAL	5-1
5-2 PRINCIPLES RELATED TO SITE CONSTRAINTS AND OPPORTUNITIES	5-1
5-3 PRINCIPLES RELATED TO BASIC SPATIAL ORGANIZATION	5-2
5-4 PRINCIPLES RELATED TO FUNCTIONAL LAYOUT	5-4
5-5 PRINCIPLES RELATED TO STRUCTURE AND ENVIRONMENTAL SUPPORT	5-5
 CHAPTER 6 – EXAMPLE DESIGNS	
6-1 GENERAL	6-1
6-2 EXAMPLE DESIGN – SCHEME A FOR 6,000 MILITARY STRENGTH	6-1
a. Situation	6-1
b. Planning Data	6-1
c. Design Solution	6-8
6-3 EXAMPLE DESIGN – SCHEME A-I FOR 6,000 MILITARY STRENGTH	6-10
a. Situation	6-10
b. Planning Data	6-10
c. Design Solution	6-10
6-4 EXAMPLE DESIGN – SCHEME B FOR 10,500 MILITARY STRENGTH	6-12
a. Situation	6-12
b. Planning Data	6-12
c. Design Solution	6-14

	Page
6-5 EXAMPLE DESIGN-SCHEME B-1 FOR 10,500 MILITARY STRENGTH	6-16
a. Situation	6-16
b. Planning Data	6-16
c. Design Solution	6-16
6-6 EXAMPLE DESIGN – SCHEME C FOR 21,000 MILITARY STRENGTH	6-18
a. Situation	6-18
b. Planning Data	6-18
c. Design Solution	6-20
6-7 EXAMPLE DESIGN – SCHEME C-1 FOR 21,000 MILITARY STRENGTH	6-22
a. Situation	6-22
b. Planning Data	6-22
c. Design Solution	6-22

INACTIVE

LIST OF FIGURES

DG 1110-3-112 May 1979

	Page
Figure 3-1 Glass Shading, South Elevation	3-7
Figure 3-2 Modular General Instruction Space	3-8
Figure 3-3 Optimum Lighting	3-11
Figure 3-4 Batwing Lighting Distribution	3-12
Figure 3-5 Pictograph of Fire Extinguisher	3-14
Figure 3-6 Safety Marking	3-15
Figure 3-7 Sound Control In Classrooms	3-18
Figure 3-8 Changeable Wall Systems	3-19
Figure 3-9 Recessed Room Exit	3-20
Figure 3-10 Identification Signs	3-21
Figure 3-11 Directional Sign	3-21
Figure 4-1 Director's Office	4-1
Figure 4-2 Administrator's Office	4-2
Figure 4-3 Information/Registration/Clerk/Typist Space	4-4
Figure 4-4 Counselor Offices	4-5
Figure 4-5 Classroom	4-6
Figure 4-6 Lecture Room	4-7
Figure 4-7 Seminar Rooms	4-8
Figure 4-8 MOS Library	4-9
Figure 4-9 Self-Paced Instruction	4-10
Figure 4-10 Language Laboratory	4-11
Figure 4-11 Science Laboratory	4-12
Figure 4-12 Testing Room	4-13
Figure 4-13 Recording Rehearsal Studio...	4-14
Figure 4-14 Heating/Refrigeration/Air Conditioning Shop	4-17
Figure 4-15 Construction Electrician Shop	4-18
Figure 4-16 Communications/IndustrialElectronics Shop	4-20
Figure 4-17 Masonry Shop	4-22
Figure 4-18 Carpentry Shop	4-24
Figure 4-19 Plumbing Shop	4-26
Figure 4-20 Diesel Mechanics Shop	4-28
Figure 4-21 Auto Mechanics Shop	4-30
Figure 4-22 Welding Shop	4-32
Figure 4-23 Auto Body Repair Shop	4-34
Figure 4-24 Small Engine Repair Shop	4-36

LIST OF FIGURES

DG 1110-3-112 May 1979

	Page
Figure 4-25 Staff Lounge	4-37
Figure 4-26 Student Lounge	4-38
Figure 4-27 Vending Area	4-39
Figure 4-28 Training Aids Preparation	4-40
Figure 4-29 Toilets	4-42
Figure 4-30 Receiving and General Storage.	4-43
Figure 4-31 Janitor Closet	4-44
Figure 5-1 Parallel Organization Scheme	5-2
Figure 5-2 Axial Organization Scheme...	5-3
Figure 5-3 Dispersed Organization Scheme	5-3
Figure 6-1 Basic Spatial Organization—Scheme A	6-8
Figure 6-2 Example Plan Scheme A—Education Center for 6,000 Military Strength	6-9
Figure 6-3 Basic Spatial Organization—Scheme A-1	6-10
Figure 6-4 Example Plan Scheme A—Education Center for 6,000 Military Strength	6-11
Figure 6-5 Basic Spatial Organization—Scheme B	6-14
Figure 6-6 Example Plan Scheme B—Education Center for 10,500 Military Strength	6-15
Figure 6-7 Basic Spatial Organization—Scheme B-1	6-16
Figure 6-8 Example Plan Scheme B—Education Center for 10,500 Military Strength	6-17
Figure 6-9 Basic Spatial Organization—Scheme C	6-20
Figure 6-10 Example Plan—Scheme Coeducation Center for 21,000 Military Strength	6-21
Figure 6-11 Basic Spatial Organization—Scheme C-1	6-22
Figure 6-12 Example Plan Scheme C—Education Center for 21,000 Military Strength	6-24

	Page
Table 2-1 Maximum Space Allowances	2-6
Table 2-2 Projected Space Type Utilization	2-7
Table 3-1 Sound Reduction Goals	3-16
Table 3-2 Cost and Flexibility of Wall Systems	3-19
Table 4-1 Summary of Environmental Criteria for individual Spaces	4-45
Table 5-1 Spatial Organization Scheme Evaluation	0-00
Table 6-1 Example Staffing for Military Strength of 6,000	6-2
Table 6-2 Typical Semester Courses and Enrollment Based on Ten-Year Projection—Example for Military Strength of 6,000	6-3
Table 6-3 Example Projected Space Type Utilization	6-4
Table 6-4 Number of Academic Spaces Needed—Example	6-5
Table 6-5 Academic Space Requirements—Example	6-5
Table 6-6 Staff Space Requirements—Example	6-6
Table 6-7 Support Space Requirements-Example	6-6
Table 6-8 Tabulated Space Requirements and Occupant Capacity Example for Military Strength of 6,000	6-7
Table 6-9 Example Staffing for Military Strength of 10,500	6-12
Table 6-10 Tabulated Space Requirements and Occupant Capacity Example for Military Strength of 10,500	6-13
Table 6-11 Example Staffing for Military Strength of 21,000	6-18
Table 6-12 Tabulated Space Requirements and Occupant Capacity Example of Military Strength of 21,000	6-19

The Design Guide (DG) series is issued under the standard design medium by the Engineering Division, Military Programs Directorate, Office of the Chief of Engineers, U.S. Army.

This guide governs design of Army Continuing Education System (ACES) Centers. The Army Continuing Education System Program is contained in AR 621-5. ACES Centers support the general academic, technical and vocational education of military personnel of all grades and ranks.

This guide provides planning and design guidance discussed separately and in the form of example designs which establish concept alternatives for evaluating project designs. This guide is applicable to all new construction projects for Army ACES Centers (Facility Category Code 740-25) and projects involving modernization of existing facilities.

Preparation of this guide was under the direction of the Special Projects Section, Structures and Buildings Systems Branch, of the Engineering Division, and is based on the results of an architectural services contract with the firms of John Carl Warnecke & Associates and George M. Ewing Company, New York, New York and Washington, D. C., under Contract No. DACA 73-73-C-0020.

Material related to functional needs has been developed in conjunction with, and approved by, the Education Services Division, Education Directorate, U.S. Army Adjutant General Center, (DAAG-EDS)

Distribution of this guide is limited. Additional essential copies are available from the OCE Publications Depot, 890 South Pickett Street, Alexandria, Virginia 22304.

Users are invited to send comments and suggested improvements to HQDA (DAEN-MPE-B) WASH DC 20314.

FOR THE CHIEF OF ENGINEERS:



LEE S. GARRETT
Chief, Engineering Division
Military Programs

1-1 PURPOSE

a. PLANNING GUIDANCE. This guide provides general guidance to aid installation and Corps of Engineer personnel in the *planning* of Army Continuing Education System (ACES) Centers for inclusion in military construction programs.

b. DESIGN GUIDANCE. As the basic instrument governing the design of ACES Centers, this guide is primarily intended to aid architects and Corps of Engineers personnel in the *development and evaluation of project designs*. This guide is directed towards the improvement of early design decisions and the development of realistic, cost-effective facilities in conjunction with Army and Department of Defense criteria and procedures.

1-2 SCOPE

a. GUIDE LIMITATION. This guide is applicable to all new construction projects for ACES Centers. It is also applicable as general guidance to projects involving the conversion or modernization of existing facilities. It applies to all construction programmed under facility category code 740-25. The guidance and criteria must be applied, however, in conjunction with information obtained from each particular installation defining the installation's proposed ACES program, and the constraints and opportunities of the project site.

b. PRESENTATION OF GUIDANCE. This guide is structured to aid in the development of project requirements and designs that respond to variables of each particular installation. Chapter 2 provides planning guidelines to help delineate ACES program requirements, space needs and cost estimates for use in developing project requirements and programming data. Chapters 3, 4 and 5 provide general design criteria, individual space criteria and space organization principles for use in developing and evaluating design solutions.

c. EXAMPLE DESIGNS. Chapter 6 contains examples illustrating the definition of requirements and designs for ACES Centers at installations with military strengths of 6,000, 10,500, and 21,000 persons. The designs demonstrate the application of criteria presented in chapters 3, 4 and 5 in view of different installation variables. While indicating a suggested level of quality, they provide a means of evaluating proposed design solutions for actual projects.

1-3 REFERENCES

a. ACES PROGRAM FUNCTIONS. The following Army documents are important in understanding ACES program functions:

AR 621-5-Army Continuing Education System (ACES)

DA PAM 570-551-Staffing Guide for U.S. Army Garrisons

INTRODUCTION

DG 1110-3-112 May 1979

1-3 REFERENCES (cont'd)

b. DOD CONSTRUCTION CRITERIA. The following manual is important in understanding the basic criteria governing the planning and design of Department of Defense facilities.

DOD 4270.1-M-Construction Criteria Manual

c. PROJECT PLANNING AND DESIGN. The following regulations are important in understanding procedures for planning and designing facilities in conjunction with the development of Military Construction, Army (MCA), programs.

AR 415-15-MCA Program Development

AR 415-17-Empirical Cost Estimates for Military Construction

AR 415-20-Project Development and Design Approval

d. COMPLETION RECORDS. The following regulation is important in understanding the kind of records transferred to the installation upon completion of project construction.

AR 415-10-General Provisions for Military Construction

1-4 EMPHASIS

a. DESIGN QUALITY. Emphasis shall be placed on the quality of design since it will vitally affect the longevity, usefulness, efficiency and attractiveness of the ACES Center. In addition to life cycle economy and functional efficiency, the overall design shall exemplify regional character and an aesthetic rendering of both interior and exterior features.

b. DESIGN SERVICES. Architects for these facilities should be selected on the basis of knowledge in design of similar facilities, and a demonstrated imaginative approach to site and building design. They must also be considered for their ability to provide and accomplish *professional interior design* services.

c. USER INFORMATION. Provisions related to the enhancement of facility operation, maintenance and flexibility shall also be emphasized during design. Information to supplement construction completion records shall be prepared to instruct the installation on how to gain the most benefit from such provisions.

1-5 RESPONSIBILITIES.

a. INSTALLATION. The Installation Commander and those who are in active charge of the installation's ACES program and real property share the primary responsibilities of the installation. The installation is responsible for:

1-5 RESPONSIBILITIES. (cont'd)

(1) Development and approval of functional requirements in conjunction with the criteria in this guide.

(2) Justification of functional requirements falling beyond the scope of criteria.

(3) Preparation and submission of the *Project Development Brochure* required by AR 415-20.

(4) Obtaining action to gain site approval if the project is not sited in accordance with the HQDA approved master plan.

(5) Preparation and submission of *DD Form 1391, Military Construction Project Data, and supporting data* in accordance with AR 415-15.

(6) Approval of concept designs to certify compliance with functional requirements.

(7) Procurement and placement of related furnishings and equipment.

b. DESIGN AGENCY. The Corps of Engineers field office responsible for design shall insure that:

(1) Functional requirements of the installation are recognized and incorporated into the project design.

(2) Requirements of the installation fall within the scope of the criteria in this guide.

(3) Requests by the installation for deviations from these criteria are completely justified and documented.

(4) Quality standards for overall design are emphasized as stated herein.

(5) Assemblage of user information is complete at the completion of project construction, and provided, together with the completion records required by AR 415-10, to the installation (Facilities Engineer).

(6) Copies of appropriate user information are provided to the director of the ACES center.

1-6 DEFINITIONS

a. NET SPACE. The Net Assignable Square Feet (NASF) used for a specific function. It includes space required for internal (secondary) circulation within areas where appropriate.

INTRODUCTION

DG 1110-3-112 May 1979

1-6 DEFINITIONS (cont'd)

b. GROSS SPACE. The total space, in Gross Square Feet (GSF), of all floors within the outside dimensions of the building excluding central mechanical equipment space.

c. FUNCTIONAL REQUIREMENTS. Space, performance and operational requirements related to staff, instructional and support activities, including circulation.

d. SPACE ALLOCATION CRITERIA. Standards prescribed to define and evaluate acceptable space allotments to satisfy functional requirements. In this guide, such criteria are often given as net assignable square feet (NASF), or in percentages or subdivisions thereof.

e. DESIGN CRITERIA. Standards prescribed to define and evaluate acceptable utilitarian, environmental and aesthetic conditions to satisfy functional requirements.

f. SPACE ORGANIZATION PRINCIPLES. Rules exemplified in the organization of spaces into a building design.

2-1 GENERAL

This chapter provides procedures to aid in development of functional requirements and subsequent preparation of planning and programing documents. The ACES program is the planning base for developing requirements which are eventually embodied into a building program. This chapter discusses building program development, and in particular, how to determine space needs and related requirements for site improvements, furnishings and equipment.

2-2 ACES: THE PLANNING BASE.

The ACES is an integrated management system of voluntary educational opportunities. It helps soldiers to grow professionally within the Army and to transfer knowledge and skills gained to productive postservice employment. It is also an Army-Wide System of relatively uniform educational opportunities, decentralized to post level, and operated within HQDA policies. The composition and size of the instructional program projected over the next 10 years for each particular case will be the basis for delineating functional requirements.

a. INSTRUCTIONAL PROGRAMS. Most military installations have authorized ACES instructional programs for a wide range of needs and backgrounds. These programs are described below:

(1) Basic Skills Education Programs (BSEP). This includes basic literacy skills thru 5th grade level, educational skills thru 9th grade level, and educational skills for progression past E-5.

(2) High School Completion Program (HSCP). This gives soldiers a chance to earn a high school diploma or a State-issued high school equivalency certificate or diploma during off-duty hours. Soldiers may enroll, with Army tuition assistance in locally available high school completion programs.

(3) Associate Degree Program. Normally, student is awarded an associate degree for successful completion of an academic or technical course of study at a two-year community or junior college.

(4) Servicemen's Opportunity Colleges Associate Degree. This program allows maximum acceptance toward a degree of non-traditional learning experiences. The soldier can meet degree requirements with a minimum of 15 semester hours of resident credit taken at any time during the program.

(5) Baccalaureate and Graduate Degree Programs. Successful completion of these programs result in the award of bachelor's and or master's (or doctorate) degrees. Each post is encouraged to have at least one of each of these programs available either on-post or within reasonable commuting distance.

(6) Skill Recognition Programs. These voluntary programs show ways to get recognition within the civilian sector for skills soldiers learn in the Army. This includes: Accreditation of Military Experience, Army Apprenticeship, Industry Recognition, Industry Specialists and Certification.

PLANNING GUIDELINES

DG 1110-3-112 May 1979

2-2 ACES: THE PLANNING BASE. (cont'd)

(7) Skill Development Programs. These programs provide technically oriented courses in support of enlisted military occupational speciality development or in furthering vocational technical development to qualify for certification, to develop a skill that is both Army and civilian related, or to build academic credits toward associate degree requirements.

(8) Language Program. This includes training to develop simple, survival-level language skills, refresher and maintenance language courses to keep and to upgrade general language skills of those with basic linguist qualifications; duty or mission-related language instruction that improves specific job performance; English-as-a-Second-Language course to upgrade basic communication skills; voluntary language courses available for personal reasons.

(9) Correspondence Courses. These courses are offered through the Defense Activity for Non-Traditional Education Support (DANTES), including high school, college, and vocational/technical courses. Courses may be supplemented by local instruction in the ACES program.

b. OTHER ACES PROGRAM FUNCTIONS

(1) Career Advisory and Counseling (CAC). CAC programs are conducted by all ACES Centers. Counseling helps each active-duty soldier grow professionally by taking part in education programs and progressing toward their educational goals. The program ensures that each soldier is offered educational opportunity as advertised.

(2) Testing. Each ACES Center is required to provide an adequate testing facility and provide testing services for the programs conducted. Tests include academic proficiency, MOS proficiency, interest, aptitude, intelligence and general placement tests. Special emphasis is placed on DANTES examinations.

(3) On the Job Training (OJT). OJT is not normally provided under the Army's ACES program, thus this function is not discussed in this design guide.

c. STUDENTS

The ACES program primarily serves active duty military personnel, but may serve adult dependents, retired military personnel, and civilian employees on the installation when space is available.

(1) Enlisted Personnel. Soldiers without a high school diploma are urged to earn a high school diploma or state-issued high school equivalency by the end of the first enlistment and do one of the following: Have occupational skills certified which are learned through Army training and experience; or, acquiring an occupational skill through the skill development program.

(2) Officers. Warrant Officers are expected to complete an associate degree program or two school years of undergraduate study by the 15th year of service. The study must be in a career field related to

2-2 ACES: THE PLANNING BASE. (cont'd)

the soldiers specialty. Commissioned Officers who lack a baccalaureate are encouraged to attain an undergraduate degree. Commissioned officers are urged to get a graduate degree. The degree may be in a discipline related to their specialty or in a shortage discipline determined by the Army Educational Requirements Board.

(3) Others; dependents, retirees, civilians, etc. Persons in this category are encouraged to make use of ACES programs, and will be admitted to programs in which space is available.

d. STAFF

For planning purposes the staff may be considered in two groups: administrative and counselor. These groups must be considered separately in terms of numbers of each type authorized. Specific staff functions and staffing levels are given in DA PAM 570-551. Instructors are normally contracted individually or from local and regional institutions, rather than being retained as permanent staff.

(1) Administrative. The administrative staff includes a director (Education Service Officer), administrators (Education Service Specialists), clerks (Administrative Specialists or Education Technicians), and typists. The administrative staff may also include a registrar, librarian and special program administrators. In some cases, individuals or institutions providing contracted services may also furnish administrative staff.

(2) Counselor. A staff of full-time counselors is authorized (one per 1,250 military personnel) to advise soldiers on the selection of courses and on career plans. AR 621-5, ACES, requires counselors to interview every new arrival at the installation during in-processing, and periodically thereafter, to assess the individual's educational background. Counselors are available to personnel throughout their stay on post.

e. INSTRUCTIONAL AIDS

(1) Audio-Visual. Films, slides, tape recorders, etc., are used to promote better learning by increasing the immediacy of experience. They are used extensively in language and reading instruction, and for teaching MOS-related material that involves the use of equipment under conditions that cannot be readily duplicated in the classroom.

(2) Self-Paced Learning. Programed instruction is frequently used, especially for MOS-related material. Students proceed at their own pace, and learning is broken down into small steps.

2-3 PLANNING REQUISITES AND DOCUMENTATION

The sequence of steps for planning is delineated in AR 415-15. Once a need for an ACES Center has been recognized by the installation, the building functional requirements and subsequent space needs

PLANNING GUIDELINES

DG 1110-3-112 May 1979

2-3 PLANNING REQUISITES AND DOCUMENTATION (cont'd)

must be established and documented along with the requirements of the site and future interior furnishings. This is the responsibility of the installation although assistance (using installation funds) may be obtained from the design agency if needed.

a. PROJECT DEVELOPMENT BROCHURES (PDB). Documentation is accomplished by first preparing a PDB as required by AR 415-20 and discussed in TM 5-800-3. Project requirements will be established in conjunction with the procedures and criteria in this guide.

b. DD FORM 1391 (MILITARY CONSTRUCTION PROJECT DATA). Preparation of DD Form 1391, with detailed justification paragraphs, is discussed in AR 415-15. Preparation of this form should be supported by the PDB previously prepared. All data entered on the DD Form 1391 must be carefully considered since project design must adhere to the requirements and estimates established thereon, as approved by HQDA. In preparing DD Form 1391, "DG 1110-3-112" should be entered under detailed justifications concerning criteria.

2-4 ANALYZING THE SITE

a. APPROVED GENERAL SITE PLAN. The site of the ACES Center must conform to the general site plan approved as part of the master plan of the installation. If the facility is not shown on the master plan, or if the shown location does not meet the current performance requirements of the using activity, then a new location must be selected and approval obtained in accordance with AR 210-20, Master Planning for Permanent Army Installations. Location is generally determined in response to the following factors.

- (1) Central to the installation and close to library facilities for convenience of students and staff.
- (2) Ready access from the main installation entrance for use by off-base personnel.
- (3) Closer to enlisted than to officers' quarters since many enlisted may not have access to automobiles.
- (4) Relatively quiet and uncontested area conducive to study.
- (5) Soil characteristics and drainage to allow economical construction and siting.
- (6) Sufficient real estate on site to permit buildings, parking, outdoor teaching areas related to vocational-training shops, access by service vehicles, and sufficient space for building expansion.
- (7) Proximity to existing or planned non-ACES spaces which are usable for ACES functions, e.g., Arts and Crafts and Auto Crafts Centers.
- (8) Proximity to dining facilities and other service facilities.

2-4 ANALYZING SITE (cont'd)

(9) Adaptable to barrier-free design for both able-bodied and handicapped persons.

b. PRELIMINARY SITE LAYOUT. Although a detailed site plan is not normally required for submission with the DD Form 1391, preparation of a site layout will assist in preliminary budgeting. Tentative orientation of the building should take into consideration the following factors:

- (1) Convenience of access for pedestrians, drivers of service vehicles.
- (2) Direction of prevailing wind and sun angles.
- (3) Land forms, grading, drainage, and tree coverage.
- (4) Views (desirable and undesirable).
- (5) Size, location and sufficiency of utility connections.
- (6) Future expansion.

c. ESTIMATING SITE COSTS. Empirical cost estimating data are given in AR 415-17. Establishing the costs of site requirements is initially the most important consideration. Therefore, specific site requirements must be determined in conjunction with building requirements, and listed as separate items (Support Facilities) on DD Form 1391. The following list indicates typical items that should be considered.

- | | |
|---|---------------------|
| Site preparation | Special foundations |
| Grading, paving (drives, parking and walks) | Fencing or walls |
| Demolition | Landscape planting |
| Water | Exterior electrical |
| Sanitary sewer | Communications |
| Gas | Signage |

2-5 DEVELOPING THE BUILDING PROGRAM

a. MAXIMUM SPACE ALLOWANCES. Table 2-1 summarizes maximum space allowances for ACES Centers based on DOD Construction Criteria. Gross space includes maximum allowance for ACES activities, including Career Advisory and Counseling (CAC), to the outside dimensions of the building excluding central mechanical equipment space. Approximate mechanical space is a rough estimate of the additional space required to individually heat and air condition each size of building in a moderate climate. Corresponding figures obtained from determining the *actual space needs* as discussed in the following paragraphs, will identify the "gross space" and "mech space" requirements to be entered (Primary Facility) on DD Form 1391

PLANNING GUIDELINES

DG 1110-3-112 May 1979

2-5 DEVELOPING THE BUILDING PROGRAM (cont'd)

Table 2-1 Maximum Space Allowances

Military Strength	Authorized (1) No. Counselors	ACES (2)	CAC (3)	Gross Space	Approx Mech Space
251-1000	1	4125	500	4625	125
1001-1250	1	8700	500	9200	150
1251-2500	2	8700	580	9280	150
2501-3000	3	8700	660	9360	150
3001-3750	3	13500	660	14160	150
3751-5000	4	13500	740	14240	150
5001-6250	5	16100	820	16920	150
6251-7000	6	16100	900	17000	150
7001-7500	6	19800	900	20700	200
7501-8750	7	19800	980	20780	200
8751-10000	8	19800	1060	20860	200
10001-11250	9	26300	1140	27440	300
11251-12500	10	26300	1220	27520	300
12501-13750	11	26300	1300	27600	300
13751-15000	12	26300	1380	27680	300
15001-16250	13	31800	1460	33260	350
16251-17500	14	31800	1540	33340	350
17501-18750	15	31800	1620	33420	350
18751-20000	16	31800	1700	33500	350
20001-21250	17	36300	1780	38080	400
21251-22500	18	36300	1860	38160	400
22501-23750	19	36300	1940	38240	400
23751-25000	20	36300	2020	38320	500
25001-26250	21	40500	2100	42600	500
26251-27500	22	40500	2180	42680	500
27501-28750	23	40500	2260	42760	500
28751-30000	24	40500	2340	42840	500
30001-40000	25-32	48000	2420-2480	50420-50980	600
40001-50000	33-40	55000	3060-3620	58060-58620	600
50001-60000	41-48	60000	3700-4260	63700-64260	650

Notes: (1) Based on DA PAM 570-551 guidance allowing 1 counselor per 1250 military strength.

(2) Allowed by DOD 4270. 1-M construction criteria.

(3) Based on DOD 4270. 1-M criteria allowing 500 SF for 1 counselor; 80 SF per each additional counselor.

2-5 DEVELOPING THE BUILDING PROGRAM (cont'd)

b. ACTUAL SPACE NEEDS. Actual space needs must be based on the requirements of the ACES Program projected over the next 10-years, and calculated in terms of the instructional space types needed, existing spaces available and compatible with such needs, and the requirements for staff and support. Actual space needs should be determined as follows:

- (1) List type and number of authorized and assigned staff for the given military strength.
- (2) List the typical semester courses and student enrollment anticipated within 10-years for the ACES program. Consideration must be given to changes in circumstances which might affect the types of courses offered as well as the projected enrollment.
- (3) Assign each course to a specific instructional space type. Use the Individual Space Criteria in Chapter 4, paras 4-3 and 4-4 for academic and vocational training type spaces, respectively.
- (4) For each instructional space type, make a table similar to Table 2-2 and find "c", the total number of hours per week that the space type is required. The maximum class size should be based on the occupant load specified for each type of instructional space as given in Chapter 4.

Table 2-2 Projected Space-Type Utilization

Space Type: Classroom

Course Designation	Typical Semester Enrollment (1) In Students	Maximum Class Size (2) In Students	Number Of Classes Required (ENRM'T ÷ Cl. Size)	Number Of Hours/Week EA Class Meets	Hrs/wk Space Required (Classes x HRS. EA)
<i>English I</i>	95 (ENRM'T)	24 (Cl. Size)	4 (Classes)	5 (HRS. EA)	20
<i>English II</i>	20	24	1	3	3
<i>Geometry</i>	5	24			
<i>Math I</i>	22	24	1	3	3
<i>History</i>	48	24	2	3	6
<i>English Lit.</i>	23	24	1	3	3
<i>Accounting</i>	60	24	3	3	9
<i>Geography</i>	18	24	1	3	3
<i>Reading</i>	17	24	1	4	4
Total Hrs/wk Space Type Required: C =					51

Notes: (1) Based on List of Typical Semester Courses and student enrollment anticipated within 10-years.
 (2) Based on occupant load data for each type of instructional space given in Chapter 4.

PLANNING GUIDELINES

DG 1110-3-112 May 1979

2-5 DEVELOPING THE BUILDING PROGRAM (cont'd)

(5) Find the number of spaces of that type required (N). Use the formula $N = c/uh$ in which:

c = total hours per week space type is required as discussed in (4)

u = room utilization rate: the fraction of time a space would be used while the ACES Center is in operation; normally $u = 0.8$

h = hours per week that ACES Center will normally operate.

If N is a fraction or a mixed number, round up to the nearest whole integer. Completion of this step will indicate the number of each type of instructional space required. Normally, a minimum of one MOS Library and Self-Paced Instruction area, and one Testing Room will be required. However, the Testing Room may be doubly used as classrooms reducing the number of those spaces which would otherwise be required.

(6) Survey Existing Suitable Facilities. Existing spaces which are or can be made available for ACES activities should have convenient access to necessary support facilities (toilets, storage, etc.). These spaces should be listed in two groups:

(a) Usable Spaces: within 8 minutes walking distance (2,000 ft.) of other ACES activities especially instructional activities, to permit movement within 10-minute class break; with no major functional problems and compatible with space allocation and other criteria in Chapter 4; and with no major problems related to operation, supervision, or availability. An Arts and Crafts Center or Auto Craft Center, in close proximity, should be considered in this group, especially with regard to providing suitable shop spaces.

(b) Conditionally Usable Spaces: over 8 minutes walk to other ACES activities but usable for courses which do not require movement to and from rest of ACES Center; and/or with functional, operational, supervision, or availability problems that permit restricted use or require extensive renovation.

(7) Determine Requirements for New Instructional Space. Subtract existing usable spaces from required spaces. Be sure that the spaces which are subtracted are compatible with the Individual Space Criteria for each type of instructional space they are to replace. Multiply the number of spaces required for each space type times the NASF space allocated for that type in Chapter 4.

(8) Determine Space Requirements for Staff. Determine staff space requirements in relation to the staff authorized and the Individual Space Criteria for staff spaces in Chapter 4. Subtract existing usable spaces as determined according to (6). Be sure that existing facilities contemplated for staff use are compatible with effective ACES operation as certain staff offices may have to be centrally located.

2-5 DEVELOPING THE BUILDING PROGRAM (cont'd)

Again multiply the number of spaces required for each space type times the NASF space allocated for that type in Chapter 4.

(9) Determine Requirements for Support Spaces. Determine support space requirements according to the individual space allowances given in Chapter 4, para 4-5. Consider use of existing spaces as support spaces especially where existing spaces are to be used as instructional and/or staff spaces.

(10) Determine Total Net Space. Add support spaces to instructional (academic and vocational training) and staff spaces to determine total NASF of new space required.

(11) Determine Gross Space. Gross space is determined by adding the space needed for such things as circulation, building walls, and utility closets within the effective outside dimensions of the building to the total net space required. One half area must be included for exterior covered passageways, balconies and stairs. A *rough* estimate of GSF required may be obtained by multiplying total NASF by a net to gross factor of 1.15.

(12) Compare Requirement Against Allowable. Check required gross space against maximum gross space allowances in Table 2-1. If the required space does not exceed the allowable, enter the figure on the DD Form 1391. If required space exceeds the allowable, revise requirements to conform with allowable. In revising the requirements, the following methods should be considered:

- (a) Use 5-year projected needs, or current needs, in lieu of 10-year needs.
- (b) Plan for use of Conditionally Usable Spaces as discussed in (6) (b).
- (c) Increase Room Utilization Rate "u" in conjunction with the formula discussed in (5).
- (d) Examine the net to gross factor for possible reduction.

(13) Determine Mechanical Space. Refer to the Approximate Mechanical Space column in Table 2-1 for a rough estimate of mechanical space needed in relation to gross space required. The actual size should be estimated by a mechanical engineer taking into account the existence of central energy sources, solar applications, etc. Enter the figure obtained on a separate line of the DD Form 1391.

c. OCCUPANT CAPACITY. Once space needs have been determined, the occupant capacity, in number of students and staff, can be determined by adding the occupant loads given in Chapter 4 for each type of instructional and staff space, taking into account the number of spaces required, by multiplying the occupant load accordingly. This will provide the maximum peak load of students and staff which might be in the building at any given time, and can be used to indicate Design Capacity.

PLANNING GUIDELINES

DG 1110-3-112 May 1979

2-5 DEVELOPING THE BUILDING PROGRAM (cont'd)

d. EXAMPLE DETERMINATIONS OF NEEDS AND CAPACITY. Development of space needs is demonstrated in Chapter 6; in most detail in para 6-2. Space requirements and occupant capacity are tabulated for the given military strengths of 6,000, 10,500 and 21,000 persons in Tables 6-8, 6-10 and 6-12.

e. ESTIMATING BUILDING COSTS. Empirical cost estimating data are given in AR 415-17. The unit cost data shown in AR 415-17 include equipment and furnishings which are permanently built into or attached to the structure. The following list indicates typical items that should be estimated as part of the building cost.

Built-in counters, cabinets, sinks and shelving.

Drinking water coolers

Central PA and speaker system

Telephone, fire alarm and intercom system

Built-in laboratory furniture, hoods and vents

Built-in typing and tape playing decks

Built-in movable partitions

Built-in projection screens

Elevators and conveyors

Waste disposers

Floor and window coverings

Chalk boards, tack boards and display cases

Signage and graphics

Special features for the handicapped

Other items which are normally installed as a permanent part of the building.

2-6 RELATED FURNISHINGS AND EQUIPMENT

a. COORDINATING REQUIREMENTS. Principal items of furnishings and equipment are listed in Chapter 4 under each individual space, generally on the figures showing space layout. Furniture and equipment that are *portable* or *detached* from the structure must be furnished by the installation. These items will be funded from some other appropriation than construction, and such must be carefully coordinated to insure availability of furnishings and equipment when required. All related furnishings and equipment needs must be identified in conjunction with Planning the building in order to develop a totally integrated and useful facility; and in order to program funds and provide information on delivery schedules in relation to construction. In preparing DD Form 1391, plans for related furnishings and equipment must be described in the detailed justifications.

b. ESTIMATING FURNISHINGS AND EQUIPMENT COSTS. Items "on hand" meeting furnishings and equipment requirements should be listed separately from items that must be procured. Sources for selection of furnishings and equipment to be procured, are provided in the GSA Federal Supply Schedules, the Federal Prison Industries Schedule of Products and the general GSA supply catalog. These sources are mandatory, insofar as they meet requirements, and cost estimates should be based on prices therein *escalated* to time of actual procurement to meet the established delivery schedule. Quality factors relevant to the selection of furnishings are discussed in Chapter 3, para 3-5. The following list indicates typical items of equipment and furnishings that should be considered.

— Audio-visual equipment, TV systems

Training equipment and instructional apparatus.

Desks, chairs, tables, study carrels

Lounge furniture

Service carts and equipment

Storage and filing cabinets

Microfilm equipment

Reproduction machines

Wall clocks; plug in

Outside furniture

Other items which are detachable or portable

3-1 GENERAL

This chapter discusses basic considerations for design and review of ACES Center projects in relation to the individual space criteria and space organization principles in Chapters 4 and 5. The discussion includes the design requisites and documentation required, basic site development and building design criteria, considerations for related furnishings and equipment and provisions for user information. In addition, there are several overriding considerations that must be accounted for in all aspects of design.

a. BARRIER FREE DESIGN. ACES Centers must be accessible to all persons. Provisions will conform to ER 1110-1-102 and EM 1110-1-103, Design for the Physically Handicapped. Barrier free design is extremely important in both site development and building design and will provide valuable conveniences to the able-bodied as well as the handicapped.

b. ENERGY CONSERVATION. Use of energy conserving techniques relates to both site development and building design. Solar orientation, building compactness, and passive conservation measures as well as active measures will be considered for application as appropriate to each individual project.

c. FLEXIBILITY. The need for flexibility primarily relates to the need to make internal functional changes that may occur during the course of normal operation. Changes may routinely occur in courses being taught, teaching or training techniques and equipment, and student load. Multi-purpose use should be considered in the design of floor loads, ceiling heights, and wall systems. Provision of adequate storage spaces is extremely important as is the capability for adapting environmental services to changing requirements. Space specifically designed for a single purpose or space containing permanently installed equipment reduces flexibility and should be limited, insofar as possible, to areas whose functional requirements dictate that multi-purpose use is inappropriate.

d. LIFE CYCLE ENHANCEMENT. During design, consideration must be given not only to the initial cost of construction, but also to the cost of operation, maintenance, and custodial care during the intended life of the building. Both initial and life costs must be analyzed, especially in the selection of utility systems, exterior materials and interior finishes.

3-2 DESIGN REQUISITES AND DOCUMENTATION.

Project design development is discussed in AR 415-20. Use of the Project Development Brochure and DD Form 1391 data as approved by HQDA for inclusion in the proposed (or approved) military construction program, is prerequisite to design development which is the responsibility of the design agency.

a. CONCEPT DESIGN. Initially, concept design drawings and analyses are required to help verify costs, and further define the functional aspects of the facility before initiation of final design. Generally, the concept design will be completed by the design agency and *approved* by the installation before construction funds are actually appropriated. The following level of detail in documentation is required.

GENERAL DESIGN CONSIDERATIONS

DG 1110-3-112 May 1979

3-2 DESIGN REQUISITES AND DOCUMENTATION (cont'd)

(1) Site Plans. Site plans will show, as a minimum, floor elevations, existing and finished grades, existing and proposed buildings, roads, parking and utilities in the immediate project vicinity, outside utility connections, signage, existing vegetation, proposed lawns and planting masses, and solar orientation. Grading, paving, utility and landscape development plans must also be shown.

(2) Design Drawings. Design drawings will include as a minimum a graphic description of the design, including floor plans, sections, and elevations, with sufficient detail to describe the geometric and construction characteristics of the building; written specifications describing the required properties and/or performance of the construction, including materials, installation, workmanship and methods; and an interior design scheme with complete schedules of finishes, colors, patterns, and furnishings and equipment (attached and detached).

(3) Design Analyses. Design analyses will contain supporting data for all aspects of the design, including architectural, structural, mechanical, electrical and communication, fire safety, etc. Cost estimates for both primary and supporting facilities, will contain basic determinations commensurate with the level of detail of the rest of the design.

b. FINAL DESIGN. Final design will be based on the approved concept design. To assure that approved concept requirements have been met, an in-process review of design documents by the installation should be made near completion of final design. Final documents must be sufficient to allow the project to proceed to competitive bidding and construction contract award. Basically, the final design will include a design analysis, drawings and specifications prepared in accordance with ER 1110-345-700, 710, and 720 respectively.

3-3 SITE DEVELOPMENT

Design of supporting facilities as part of the site development will be consistent with the project requirements previously established. Successful site design is embodied in developing an appropriate relationship between building and site, an efficient vehicular and barrier-free pedestrian system, and an overall landscaping and signage plan. These considerations are discussed in the following paragraphs. Reference should also be made to TM 5-803-3, Site Planning.

a. BUILDING-SITE RELATIONSHIP. In developing an appropriate building-site relationship, the terrain, soil characteristics, local vegetation, and climatic conditions of the site must be considered along with the utilities support, and relationships to other buildings in the area.

(1) Terrain Configuration and Site Coverage. The site design process requires analysis of the scale and character of the geographic and topographic features of the site. Large scale features, such as site slope characteristics, generally require specific architectural and landscape responses. Both large and small scale features should be considered from the standpoint of their potential landscape value. The building should be designed to blend with the contours of the terrain. If other considerations, such as solar orientation, dictate that the building cross contours, a multi-level building may be desirable. As a

3-3 SITE DEVELOPMENT (cont'd)

rule of thumb, the maximum recommended coverage of the site by the building is 40 percent. Optimum coverage is generally considered to be about 30 percent. Allowances for future expansion should also be considered.

(2) Soil Characteristics and Drainage. The organic composition and drainage characteristics of the soil is important to the design of building foundations and the economy of construction, as well as to the landscaping of the site. The drainage characteristics and compressive bearing strength of the soil are critical in foundation design and must be determined in accordance with TM 5-818-1, Procedures for Foundation Design of Buildings and other Structures. The determination of soil drainage characteristics will also include assessing the effects of the proposed building and its adjacent paved areas on the ground water level. Overlot grading must be established to provide positive drainage of the entire site away from the building and outside facilities. Grading should be designed for optimum preservation for existing ground forms and drainage patterns.

(3) Vegetation and Tree Coverage. Existing vegetation and trees should be preserved in their natural setting to the greatest extent possible consistent with functional requirements. This can help reduce the environmental affects of wind and sun, as well as the requirement for landscape planting and temporary erosion controls.

(4) Climatic Conditions. Skillful utilization of natural environmental controls can significantly increase building utility and efficiency.

(a) Wind. Structures affect air movement. They block or divert winds or channel them through narrow openings. Normally, the entrance should face away from the prevailing winds, or should be shielded by vegetation or part of the building. Features should be placed on the site so as to control wind-blown trash or snow, and aid in dispersal of emissions (smoke, fumes, dust).

(b) Sun. Solar controls should be planned to help achieve maximum energy savings. External shading devices are the most effective means of solar shading. Deciduous trees can provide shade in summer and penetration of sunlight in the winter.

(5) Exterior Utilities. Utility support systems must be carefully analyzed with respect to location, connection into the building and subsequent operation and maintenance. Utility areas, such as for transformers, utility connections, etc., shall be screened by use of plantings, land forms, or architectural screens to blend with the surroundings.

(6) Relationship to Other Buildings. The ACES Center will have been located during the planning process so as to establish some relationship to other community-type facilities. Subsequently, the site must be arranged to develop the relationship between the ACES Center and any existing spaces being used as well as the main library and service facilities such as the exchange, commissary, etc.

GENERAL DESIGNS CONSIDERATIONS

DG 1110-3-112 May 1979

3-3 SITE DEVELOPMENT (cont'd)

b. PEDESTRIAN AND VEHICULAR SYSTEM. A safe and convenient pedestrian and vehicular system must be established. The system should separate pedestrian and vehicular activities as much as possible and incorporate requirements for the physically handicapped in accordance with EM 1110-1-103.

(1) Walkways. The pedestrian system is essentially established by the pattern of walkways designed to support access and egress to and from usable entrances of the ACES Center. Generally, walkways should be designed to complement the natural flow of pedestrian traffic, be 6' wide, and slope no more than 1 in 24 blending to a common level with other surfaces. Where significant level changes are required, both steps and ramps should be provided. Walks crossing roadways must be marked and provided with curb ramps, if curbs are used.

(2) Roadways. Vehicular arterials should not run through the ACES Center grounds or between the Center and closely related facilities such as the library. A pedestrian drop-off and pick-up zone should be provided near the main entrance to the Center, and be designed to be barrier free.

(3) Parking. A principal part of the vehicular system involves parking facilities for the cars and motorcycles of students and staff. The number of parking spaces required shall be based on a traffic analysis at the installation, taking into consideration time and space intervals related to the ACES instructional activities, and available mass transportation, car pooling, etc. A portion of the car parking spaces will be designed for use by handicapped drivers and *carefully* located to avoid having to cross a roadway to gain access to the building. Parking should be orderly and if possible dispersed and accented with landscape features.

(4) Service Access. Service roads and areas should be separated whenever possible from pedestrian oriented roadways, parking and walkways. In the outside areas related to vocational training; service requirements, car storage and parking may be combined. However, it is essential that the vehicular system provide access for fire fighting equipment, trash removal and other servicing equipment as well as for deliveries. Service areas and service roads must be sized to accommodate the turning radii and maneuvering requirements of the largest vehicles. At the same time, the extent of paving should be minimized. Screening for service areas should be accomplished in conjunction with the screening of utilities features.

c. LANDSCAPING AND SIGNAGE PLAN. In conjunction with establishing the building-site relationship and the pedestrian-vehicular system, a landscaping and signage plan will be developed.

(1) Signage. Direction signs and signs identifying buildings, parking areas, service areas, and facilities for the handicapped are required and shall be developed as an overall system together with the signage required for the building. Design shall conform to the signage criteria discussed under Building Design.

3-3 SITE DEVELOPMENT (cont'd)

(2) Landscape Perception. An important part of the landscape plan is consideration for the visual experience. A landscape is usually seen from an unlimited number of viewpoints, but a selected set of viewing positions can be designed into the landscape plan from where special features would be enhanced when viewed from those positions. Viewing positions will be established in conjunction with the design of the pedestrian system and the architectural image of the building. Sight lines from these positions must be carefully analyzed with respect to the visual and other aesthetic experiences to be created by the landscape plan; and with respect to the overall image to be established for the ACES Center. Sight lines from inside building windows are also important in developing the landscape plan as windows often function as focal points on the landscape as well as provide natural light.

(3) Planting Design. Existing land forms, trees and vegetation should be preserved and incorporated into the landscape plan wherever possible. Plants can be used to modify or enhance climatic characteristics, reduce noise levels and control the flow of air. New plant materials should be available locally, easily maintained, and compatible with the surrounding environment without excessive irrigation needs. Where new materials are used, the initial plant size should be adequate to give the desired visual and protective effects. Parking areas should be screened with buffer planting and variegated with substantial islands of vegetation. For details on planting design, reference should be made to TM 5-830-1.

(4) Outside Furnishings. Where outside instructional activities or other functions such as study or waiting occur, appropriate furniture and equipment will be provided as part of the overall landscape plan. Provide bicycle racks to accommodate bicycle parking as appropriate. Trash receptacles, bollards, light standards and other common site elements shall be designed as part of an overall scheme. Items, fully attached to the site or building, will be included as part of the construction contract. Portable items will be included as part of the Related Furnishings and Equipment information to be developed for procurement by the installation.

(5) Lighting. Provide general parking and walkway lighting of 2 foot-candles at ground level. Areas accessible to the handicapped after dark must be lighted to 5 foot-candles at ground level.

3-4 BUILDING DESIGN

Building design will basically conform to the project requirements previously established, and applicable DOD, Army and Engineer criteria. The quality of building design may very well determine whether or not the ACES facility will maintain its usefulness and value. In this respect, successful development of the building's architectural image, functional layout, structure and environmental support systems, and interior detailing is of prime importance.

a. **ARCHITECTURAL IMAGE.** The architectural image is established by the characteristics of design that make the building appear inviting, adapted to the environment, and identifiable as an ACES Center.

GENERAL DESIGN CONSIDERATIONS

DG 1110-3-112 May 1979

3-4 BUILDING DESIGN (cont'd)

(1) Inviting Design Characteristics. The ACES Center must be inviting and convenient to visitors as well as routine users. Especially important are the location, expression, and identification of entrances in relation to the approaches on the building site. The design of the ACES Center should reflect the scale and nature of the activities involved and invite participation therein.

(2) Adaptation to Environmental Context. One measurement of good building design is the success with which the facility is adapted to its particular environment. Specifically, such factors as site and climate provide the basis for determining appropriate architectural responses. For example, a hot, sunny environment requires a facility that provides protection from heat and glare, with entrances that accomplish a comfortable transition between the bright sun on the exterior and the relatively dark interior. In wet climates, rain protection at exits and between building elements should be considered, and in colder climates, compact buildings that increase floor space per unit area of exterior surface and door circulation should be used. Environmental considerations such as these are an integral part of an attractive and functional design.

(3) Facility Identity and Perception. The ACES Center building must be readily identifiable as a unit and have a visually apparent organization that facilitates orientation and circulation. These basic perceptual qualities are essential to the further development of a system of viewing positions and settings to communicate the aesthetic intent of the building design. A series of viewing positions, intentionally planned into the approaches to the building and continuing on into the space organization within, shall be established for this purpose, and identified in the design analysis. The settings will be composed of elements of the building design, such as the sizes and shapes of the building's exterior masses and interior spaces, the color, texture and lighting of those elements, and the visual articulation or decoration thereof.

(4) Exterior Detailing. The color, texture and scale of building materials should generate visual interest, as well as establish characteristics appropriate to the overall scale and image of the installation. The articulation of the exterior mass of the building is also an important consideration.

(a) Wall Shading. A substantial proportion of the air conditioning requirement for most buildings results from solar energy absorbed by building surfaces. By simply shading those portions of building receiving the most sun, cooling requirements can be significantly reduced. Methods of wall shading which should be considered include applying various forms of canopies or louvers to the walls, and use of deciduous trees. Each wall of the building may require a different treatment depending upon its orientation to the sun.

(b) Control of Glass Areas. In cases where the shading methods (mentioned above) are not practical, the choice of window glass becomes important. At a radiation angle of incidence of 40 degrees, ordinary glass admits 85% of the solar thermal energy that strikes the glass surface, while reflective glass admits 63%, heat-absorbing glass 60% and certain specialized glasses as little as 28%. Windows may also be recessed as illustrated in Figure 3-1. Such a design shades the window glass, substantially reducing the amount of solar energy striking the glass surface.

3-4 BUILDING DESIGN (cont'd)

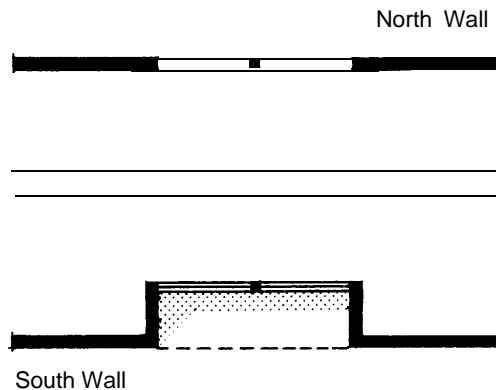

Figure 3-1 Glass Shading, South Elevation

b. FUNCTIONAL LAYOUT. The layout of ACES facilities is an extremely important part of the building design, affecting both the operational efficiency and performance of ACES activities as well as the cost of construction. An effective functional layout must relate to a standard space module, accommodate circulation flow and adjacency requirements, and conform to life safety criteria.

(1) Standard Space Module. Buildings are generally more economical to construct if designed in relation to a standard space module. A commonly accepted module in the building industry is the 5-foot square. Systems such as for ceilings, walls, lighting and air distribution are manufactured to readily adapt to the 5-foot module. Space allocation criteria contained in Chapter 4 reflect use of the 5-foot module in defining the NASF allowed for the various functions of the ACES program.

(2) General Instruction Space Modules. instructional spaces are required that will seat 12 to 25 students, occasionally up to 50; be easily convertible to other uses; and minimize disruption of activities during modification of use. Based on these requirements, a general instructional module of 30' x 25', expandable to 30' x 50' as shown in Figure 3-2 will be used where practicable. This 750 SF module provides ample space, in the proper dimensional proportions for 25 students seated at tables, for general classroom activities. Two 750 SF modules placed side by side form a 1500 SF module ample enough for 50 students for large lecture activities. Divided by fixed or movable walls into 375 SF modules, there is ample room for 12 students for seminar purposes.

(3) Adjacency Requirements. In developing the building design to meet the performance needs of the ACES program, spaces must be laid out to achieve essential adjacency relationships. Basically, there are three kinds of spaces needed to accommodate ACES program functions; staff spaces, instructional (academic and vocational) spaces, and support spaces. Each group of spaces represents in itself an overall adjacency relationship. The relationship of one group to another is an element of basic spatial organization as discussed in Chapter 5. The relationship of one individual space to

GENERAL DESIGN CONSIDERATIONS

DG 1110-3-112 May 1979

3-4 BUILDING DESIGN (cont'd)

another, as discussed in Chapter 4, is an element of functional layout. Generally, this is based on the degree of interaction of personnel, material or activities between two or more spaces. The greater the degree of interaction, the closer the spaces should be together unless there are interposing requirements for safety, or need for acoustic or visual separation.

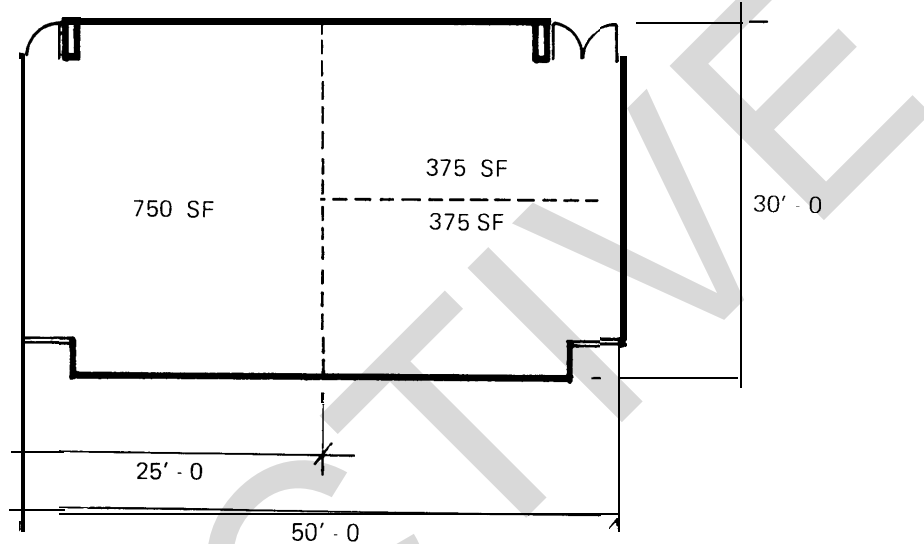

Figure 3-2 Modular General Instruction Space

(4) Circulation Flow. Corresponding with the layout of space adjacencies, a convenient and workable circulation flow must be established. The flow of students and staff; materials and services should not interfere with one another even though they must interface at certain points. Circulation requirements will greatly depend upon how well adjacency requirements are satisfied, and whether or not space organization assists orientation to the building. Spaces used frequently by persons unfamiliar with the ACES Center should be near the main entrance, and those that generate heavy traffic should be located close to entrances or circulation nodes. Like most education facilities, there will be predictable surges of circulation at the beginning of the instructional day, during break periods and the lunch hour, and at the end of the instructional day. Circulation systems must be capable of safely and comfortably handling these routine peak loads as well as those that might be experienced during an emergency evacuation of the building.

(5) Circulation Nodes. Horizontal circulation spaces should widen at points of queuing and decision, such as at corridor intersections, toilets and entrances to stairways. Such nodes should permit places for people to pause and possibly sit. At building entrances, the circulation space must provide for entering personnel to orient themselves and exiting personnel to prepare for outdoor

3-4 BUILDING DESIGN (cont'd)

weather conditions. A circular node should also be provided at elevators required to accommodate physically handicapped persons in multi-storied facilities.

(6) Evacuation. The building's functional layout must conform to life safety requirements. Evacuation during an emergency depends upon getting all of the occupants out of the building safely. This, in turn, means that limitations may have to be placed upon space sizes, locations and distances from exits. Also exits and passageways from the building must be sufficient in number and size. In most emergencies, elevators will become unusable; therefore, rescue areas or other measures may have to be considered for protection of the handicapped in multi-storied buildings.

(7) Related Considerations. Functional layout may also be affected by other considerations. For example, areas where surveillance is desired should be laid out in such a way as to allow visual control of circulation and other activities. Spaces with functions having common characteristics such as high noise levels or fire hazards; or special requirement for interior detailing, structure and environmental support; should be grouped together insofar as functional requirements for adjacencies will allow. Analyses should incorporate these and other considerations as appropriate to meet the requirements of each individual project.

c. STRUCTURE AND ENVIRONMENTAL SUPPORT. A successful building design must provide economical structure and environmental support systems selected for their ability to effectively support functional requirements and to operate efficiently. Environmental support includes heating, ventilation and air conditioning, lighting, electrical power and communication, plumbing, fire safety and acoustics.

(1) Structural Design. Design Loads and criteria will be in accordance with DOD 4270. 1-M and TM 5-809-1 through 6, 8 through 12. The structural systems and materials selected will be suitable for permanent type construction, be capable of carrying the required loads, conform to the standard space module, and be compatible with fire protection requirements, architectural concepts and functional requirements. The structure selected will be that system which is the most economical and suitable based on comparative cost studies for the building.

(2) Protective Construction. Design of structures for protection against seismic events and wind storms is prescribed in TM 5-809-10 and TM 5-809-11 respectively. In locations where a deficit in PF 100 fallout shelter space exists under the Army Survival Measures Plan, described in AR 500-72, selected areas of the structure will also be designed for dual use as fallout shelters. Technical and other requirements will be in accordance with TM 5-800-1, Construction Criteria for Army facilities. Single-line plans showing locations, occupant loads, and minimum protection factors for the selected shelter areas shall be developed and included in project design analyses and completion records.

(3) Ventilation, Temperature and Humidity Control. A controlled thermal environment is an important factor in designing comfortable, safe, and effective instructional spaces. Investigations in the area

GENERAL DESIGN CONSIDERATIONS

DG 1110-3-112 May 1979

3-4 BUILDING DESIGN (cont'd)

of human performance show that when temperature and humidity become high, working efficiency decreases, errors increase, and under extreme conditions health is adversely affected. In areas such as shops, in which students are working with equipment and machinery, temperature and humidity control may be required for safety purposes. Likewise, ventilation or exhaust systems may be required for health. All provisions must be consistent with applicable Occupational Safety and Health Act (OSHA) standards.

(a) Temperature Control. Whenever the daytime outside temperature is above 55 degrees F., heat gains will usually outweigh losses. Therefore, the fundamental problem in controlling the thermal environment in an ACES Center is cooling, rather than heating the facility. The desirable temperature for a building depends on the activity of its occupants. Acceptable temperature limits vary from 60-70 degrees for vigorous activity to 68-78 degrees for sedentary activity. In an ACES Center, where learning activities range from sedentary to vigorous, separate temperature zoning should be provided. For example, shop areas should be zoned for lower temperature than classrooms or staff areas.

(b) Humidity Control. Relative humidity has little influence on comfort, provided that it is in the intermediate range (30% to 70%). Humidity levels above 70% can impair human performance and levels below 30% can cause respiratory discomfort and create undesirable levels of static electricity in activity spaces.

(c) Ventilation. In a closed, occupied space, the amount of oxygen in the air decreases and the amount of carbon dioxide increases. Normally, ventilation of 6-10 air changes per hour is sufficient for maintaining the proper balance between oxygen and carbon dioxide. Dust, pollen, and bacteria should be eliminated by air filtration. Ventilation criteria for individual spaces are summarized in Chapter 4, Table 4-1. Air distribution systems should provide uniform air velocities generally not exceeding 40 feet per minute for an air-conditioned draft-free environment.

(4) Mechanical Design. Heating, air conditioning and mechanical ventilation shall conform to the applicable portions of DOD 4270. 1-M and TM 5-810-1. Heating and air conditioning load calculations shall comply with the procedures of the latest ASHRAE Handbook of Fundamentals. The "U" values for exterior walls, ceilings, and floors shall be in accordance with DOD 4270.1-M. Design temperatures shall be 68°F. for heating; 78°F. for cooling. Various systems should be considered to accommodate the environmental requirements of the different types of spaces in the ACES Center. Selection will be based on performance, least energy use and cost of operation and maintenance. Energy recovery systems should be investigated and incorporated into the design if economical. Reasons for selection and rejection of systems must be included in project design analyses.

(5) Lighting. An appropriate visual environment with adequate lighting is essential for effective learning. A well lighted classroom enhances auditory as well as visual perception.

(a) Illumination Levels. Research has established that a lighting level between 20 and 50 foot-candles is adequate for the comfortable and efficient completion of most tasks. However, it is

3-4 BUILDING DESIGN (cont'd)

recommended that illumination be designed to supply 70 foot-candles on all educational and office tasks, since accurate reading of pencil handwriting demands higher illumination levels than most other visual tasks. Lighting levels higher than 70 foot-candles are not required. Lighting level criteria for individual spaces are summarized in Chapter 4, Table 4-1.

(b) Adapting to Illumination Changes. In moving from one space to another, an important consideration is the ability of the eye to adapt to light and darkness. Only 35 seconds are required for partial, yet safe, adaptation when moving from a dark space to a lighted area. When moving from light to dark, however, minimal adaptation requires two minutes, total adaptation up to half an hour. Since personnel entering the ACES Center will be coming from the outdoors, where the level of illumination may be anywhere from 2,000 to 5,000 foot-candles, it is important to provide adequate lighting in entry spaces to permit gradual adaptation to interior light levels.

(c) Lateral Differences in Illumination. When personnel are placed in an environment where illumination on either their left or right is significantly greater than that on the opposite side, their eyes are subjected to distracting and uncomfortable stresses. This situation often occurs in classrooms where windows allow exterior light to stream in from one side of the students' field of vision while the other side is more dimly lighted from the interior. Avoid such conditions by designing the seating so that the windows are behind the students or when this is not possible, moderate the entering light with shading or other light-attenuating devices.

(d) Task-Background Illumination Levels. In general, the task (paper, book, item of equipment) confronting the student should be brighter than the surrounding environment. For optimum contour and depth perception, it should be three times as bright. Contrasts greater than this produce distortions. In no case should the task illumination level exceed ten times the general lighting level.

(e) Veiling Reflections. Design lighting so as to minimize light which is reflected off the task or nearby surfaces directly into the student's eyes. In general, this involves selecting and placing the light fixture so that the angle of incidence measured from the vertical is greater than 30 degrees, with as much light as possible falling within the 30 to 60 degree core as shown in Figure 3-3.

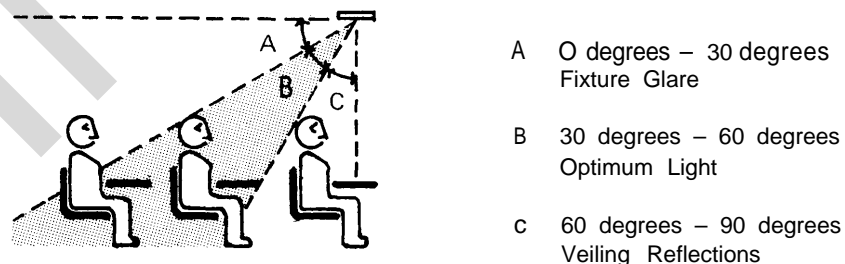

- A 0 degrees – 30 degrees
Fixture Glare
- B 30 degrees – 60 degrees
Optimum Light
- c 60 degrees – 90 degrees
Veiling Reflections

Figure 3-3 Optimum Lighting

GENERAL DESIGN CONSIDERATIONS

DG 1110-3-112 May 1979

3-4 BUILDING DESIGN (cont'd)

(f) Glare. Design lighting so as to minimize light shining directly from the light sources into the student's eyes. This can be accomplished by selecting and placing light fixtures to direct the light below a 60 degree angle of incidence, with, again, as much light as possible falling in the 30 to 60 degree core (see Figure 3-3). Lighting fixtures with low brightness characteristics that produce a "bat-wing" light distribution pattern, as shown in Figure 3-4, are one means of satisfying this requirement.

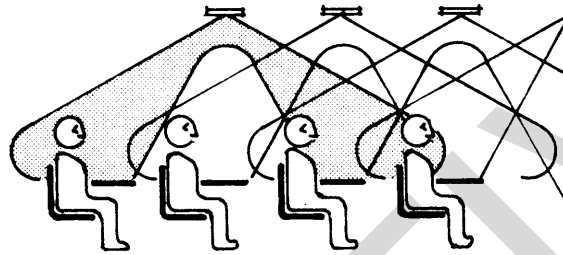

Figure 3-4 Bat-Wing Lighting Distribution

(6) Communications. The building telephone and intercommunication requirements are summarized in Chapter 4, Table 4-1. Telephones and lines will be provided by the installation Communications/Electronics Officer, however, outlets and the distribution system must be provided as part of the building design.

(a) Intercom-PA System. Provide an intercommunication-public address system consisting of a master station in the staff area capable of selectively paging through individual loudspeakers in selected areas and offices. The loudspeaker stations should be the talk-back type, and include a conveniently located master station call button. The master station should have volume controls on input and output, an all-call feature, and indicators for announcing incoming calls. Speakers should be the flush-mounted type. Medium and large size classrooms must be furnished with receptacle and wiring for microphones and speakers for amplified audio distribution.

(b) Central Television System. Where a central television system is required, the system must be coordinated with the installation Communications/Electronics Officer at the earliest practicable phase of design. TV outlets must be located for convenience, given the room layout and functional activity involved. Choice of using existing CATV or MATV system facilities, or the provision of a complete building antenna must be determined. Where a non-Government owned system is to be utilized, built-in system features such as empty conduits and pull wires, terminal cabinets, and outlets only will be provided in the building design.

3-4 BUILDING DESIGN (cont'd)

(7) Electrical Design. Electrical design must conform to DoD 4270.1-M and TMs 5-811-1 through 4. The system selected will provide efficient and economical electrical service throughout the ACES Center. Voltages selected will be of the highest order consistent with the load served. Three phase 208Y/120 volts should generally be used to serve incandescent and small fluorescent or mercury vapor lighting loads, small power loads, and receptacles. Consideration should be given to the use of three-phase 480Y/277 volt systems where such is feasible. Distribution of power within the building should be located to afford maximum flexibility in room power supply and ready accessibility for circuit revisions. Primary electric service will be underground to a pad mounted transformer(s) located outside below grade where possible, and as close to the load centers as practicable. Building telephone service will also be underground with main terminal cabinets located in mechanical or electrical equipment rooms. Communication systems must be coordinated with the local Communications/Electronics Officer. Evidence of such coordination will be provided in the project design analysis document.

(8) Toilet Fixtures. Both female and male toilets shall be provided to allow for convenient use by staff and students, including those who may be handicapped. Male-female ratio and fixture allocation are specified in Chapter 4 under individual space criteria for toilets, paragraph 4-5.e. At least one water closet and lavatory for each sex will be provided for the physically handicapped in accordance with the distance of travel and other criteria contained in EM 1110-1-103. Provide at least one drinking fountain per 100 persons. All computations should be based on the peak daily occupant load determined by adding up the occupant loads of all of the instructional and staff space in the ACES Center.

(9) Plumbing Design. Plumbing must be in accordance with TM 5-810-5 (and TM 5-810-6 if gas fittings are required). Water supply facilities must be as prescribed in TM 5-813-3 and 6. Sanitary sewers must be as prescribed in TM 5-814-1. Plumbing and fixtures shall comply with the "American National Plumbing Code A 40.8" or the "National Standard Plumbing Code," within the limits established by DoD 4270.1-M.

(10) Life Safety. Design provisions shall be made to assure health and safety as set forth in Occupational Safety and Health Act (OSHA) standards and National Fire Protection Association (NFPA) Codes augmented by DOD and Army criteria. Fire protection is a significant part of building design and involves the provision of resistive construction, detection and alarm systems, and extinguishment systems.

(a) Resistive Construction. Requirements for fire-rated walls, doors, floors, etc., depend upon the type of occupancy or hazards within a space. The objective is to contain and retard fires to allow evacuation, rescue and extinguishment. Resistive construction is especially important around passageways used for emergency exit.

(b) Detection and Alarm. Alarm systems are used as a general alert of danger whenever a fire occurs and is detected. Alarms can be supplemented by either heat or smoke detectors that sound an

GENERAL DESIGN CONSIDERATIONS

DG 1110-3-112 May 1979

alarm automatically. In designing a system, consideration should be given to visual as well as audible alarms to aid those with hearing handicaps; to resisting vandalism; and to maintaining and checking the system's performance. Tie-in with the installation fire department may also be required along with annunciators to show which detectors and/or alarms are activated.

(c) Extinguishment. Sprinkler or other systems may be used or required in high hazard areas, e.g., in educational or storage spaces where hazardous materials are handled. These systems are normally activated automatically by heat. An automatic sprinkler system shall be provided in all portions of ACES Center buildings located below the floor of exit; in all windowless classrooms, shops and educational spaces not having exits leading directly to the outside; and in all shops, classrooms and storerooms in which hazardous materials are handled. Spaces where special electrical or mechanical devices such as computers, simulators, etc., are to be housed must be identified so that alternative extinguishment systems can be designed accordingly.

(d) Safety Signals, Lights and Symbols. Emergency exits from corridors should be marked so that a sign indicating the nearest exit is visible from every point in the corridor. Provisions for those with visual, as well as other physical impairments, must be made in accordance with applicable design criteria used in design for the physically handicapped. Illuminated exit signs and emergency lights for all emergency exits and passageways will be provided as required by the Life Safety Code, NFPA No. 101. The location of fire protection and other fire safety equipment should be emphasized, where possible, with pictographs such as shown in Figure 3-5. Safety markings; signs for danger, warning or caution such as shown in Figure 3-6, should be designed in accordance with AR 385-30, Safety Color Code Markings and Symbols, and OSHA requirements.

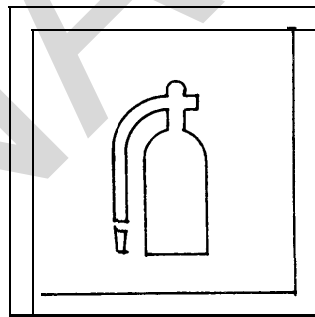

Figure 3-5 Pictograph of Fire Extinguisher

3-4 BUILDING DESIGN (cont'd)**Figure 3-6 Safety Marking**

(11) Fire Protection Design. Criteria for fire protection, including fire and/or smoke detection, fire alarm and extinguishment systems, are prescribed in DoD 4270.1-M, TM 5-812-1 and TM 5-813-6. These are generally based on the NFPA's National Fire Codes. Corridors, rooms and exits must conform to the requirements for "flexible plan" buildings given in the NFPA Life Safety Code 101. Single-line plans showing fire-rated construction, location of detection and alarm systems, the location of exits and travel distances to them, areas where sprinkler and/or extinguishing systems are provided, and the location of other fire protection features shall be developed and included in project design analyses and completion records. These documents will indicate coordination of the fire safety design with the installation fire marshal.

(12) Physical Security. The lock and keying system along with requirements for intrusion detection and protective lighting must be coordinated with the installation facilities engineer. Normally, locks will be grand master keyed to the installation's master key system and with the ACES Center keyed to a sub-master key. The further need for master keys for selected parts of the Center should be considered. Overall, the physical security system must be designed so that its operation can be maintained effectively without interfering with life safety features.

(13) Acoustics.

(a) Ambient Noise. Ambient noise is the background noise associated with a given space. It is generally a composite of sounds from mechanical equipment, street noise, and noise from nearby habitable spaces. The design ambient noise level for each ACES Center space is given in Chapter 4, Table 4-1 in terms of A-weighted sound levels in decibels (dB).

(b) Generated Noise. Generated noise is the estimated overall peak airborne sound level in a given space, created by typical activities. The peak estimated sound levels for each individual space are also given in Table 4-1 for consideration in determining noise compatibility. These levels are generally 10-15 dB higher than the average long-term levels should be for each respective space.

GENERAL DESIGN CONSIDERATIONS

DG 1110-3-112 May 1979

3-4 BUILDING DESIGN (cont'd)

Table 3-1 Sound Reduction Goals

GROUP 1	Rehearsal Recording Studio				
GROUP 2	Director's Office Administrator Office Clerk Office Counselor Office MOS Library Testing Room	40	55	60	
GROUP 3	Classroom Lecture Room Seminar Room Language Laboratory Science Laboratory Self-Paced Instruction	40	45	50	65
GROUP 4	Staff Lounge Student Lounge Vending Area Training Aids Preparation Typist Area Information/Registration	40	45	50	70
GROUP 5	Htg/Refrig/AC Shop Electrical Shops Automotive Shops Building Trades Shops Toilets Receiving Room	40	45	55	varies
GROUP 6	Storage Areas		no acoustic requirement	varies	no acoustic requirement

Numbers represent sound reduction goals in decibels (dB) between spaces

Sound reduction should be measured in accordance with ASTM E 597-77T

3-4 BUILDING DESIGN (cont'd)

(c) Sound Quality. This relates to the type of response a room should make to the noise generated within. A "live" room should have a low average absorption coefficient with hard surfaces to reflect most of the sound. Conversely, a "dead" room should have a high absorption coefficient with surfaces to absorb sound. Values given in Chapter 4, Table 4-1 for sound quality are abbreviated as follows: L = live, ML = medium-live, AVE = average, MD = medium-dead, D = dead.

(d) Sound Reduction. Building design should allow a reduction in sound between ACES spaces as indicated in Table 3-1, Sound Reduction Goals. Each group of spaces have similar acoustic requirements. Reduction is achieved by a combination of interposed distance and barriers.

(e) Maximum Sound Level. Loud and sustained noise can be a hazard to hearing. The safe limit for an unprotected ear is approximately 135 dB. At 150 dB even short-term exposure may cause damage. These facts have important implications for the design of shop areas, where high intensity noise is frequently a problem.

(f) Effect of Distance and Interposing Barriers. Sound dissipates over distance. Doubling the distance from a sound source reduces the level of sound received by 6 dB. A similar reduction occurs for each doubling of distance between source and receiver. The operation of heavy armor or transportation equipment produces between 80 and 120 dB of sound at a distance of 20 feet. Aircraft may produce in excess of 140 dB. Assuming 100 dB at 20 feet, such sound would diminish to 94 dB at 40 ft., 88 dB at 80 ft., 82 dB at 160 ft., 76 dB at 320 ft., on up to 34 dB at 40,000 ft. (7 1/2 miles), etc. Since 35 decibels is the maximum desired ambient noise level for classrooms and study areas, distance alone generally is not a practical solution to reducing sound between the classroom environment and the outside environment or other related environments containing high noise producing sources. However, if such sources can be located at a distance remote enough to allow reduction of the noise to an ambient noise level around classrooms of 65 decibels, normal construction barriers can be reasonably designed to further reduce the noise to acceptable ambient levels within the classroom.

(g) Background Noise. Background noise is most distracting when the frequency range of the desired audio stimuli and the background noise are similar. For example, voice noise of 35 dB is more disruptive than mechanical ventilation noise of 35 dB.

(h) Reflective and Absorptive Surfaces. To reinforce an instructor's voice and help eliminate distracting reverberations in classrooms and other similar rooms, the ceiling, the wall behind the instructor's station, and the upper half of the side walls should be provided with sound reflective surfaces as shown in Figure 3-7. The remaining surfaces of the room should be sound absorptive so that noise generated close to the floor, e.g. dropping objectives, scuffling of shoes, or the moving of chairs, is reduced.

GENERAL DESIGN CONSIDERATIONS

DG 1110-3-112 May 1979

3-4 BUILDING DESIGN (cont'd)

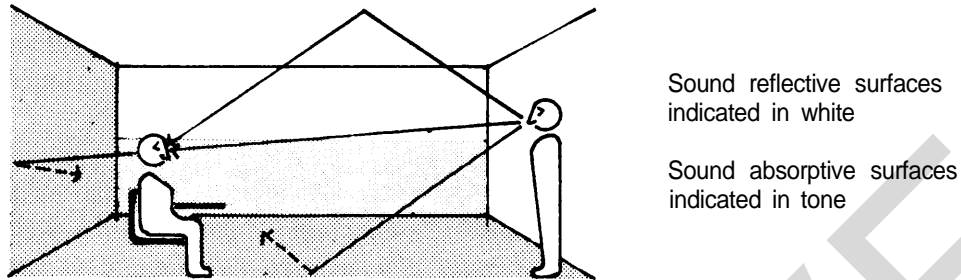

Figure 3-7 Sound Control In Classrooms

(i) Structural Considerations. Sounds should be isolated and/or reduced at their source, if possible. Machines producing high intensity sound can be enclosed with sound absorbing walls or shielded with sound absorbing material. Machines that produce high-intensity structure-borne sound should be acoustically isolated by special mounts.

(j) Mechanical Considerations. Air conditioning ducts may have to be treated to reduce noise transmission through the ducts. Space above ceilings, provided for distribution of ducts and other mechanical or electrical items, can allow excessive noise transmission from one space to another. Where such cases may occur, walls or partitions should extend up to the underside of the roof or floor above.

d. INTERIOR DETAILING. The attractiveness and overall usefulness of the building is directly affected by the interior detailing of the building design. Interior detailing will be developed in conjunction with an overall interior design so that items which are part of the building contract are coordinated with related furnishings and equipment to be procured separately by the installation. Interior wall systems, finish materials, signage and color applications must be carefully considered in this regard.

(1) Interior Wall Systems. Permanent walls should be held to a minimum necessary for structural and fire resistance purposes. Transverse walls where practical should be semi-permanent or movable. Employ movable walls in those spaces in which changes in function or class size are relatively frequent. Figure 3-8 shows some of the basic characteristics of the most common types of movable and semi-permanent interior wall systems. Table 3-2 provides data on the comparative cost and flexibility of wall systems. The designer must develop an accurate estimate of the frequency of functional change in a given space, and on that basis, select an appropriate interior wall system.

3-4 BUILDING DESIGN (cont'd)

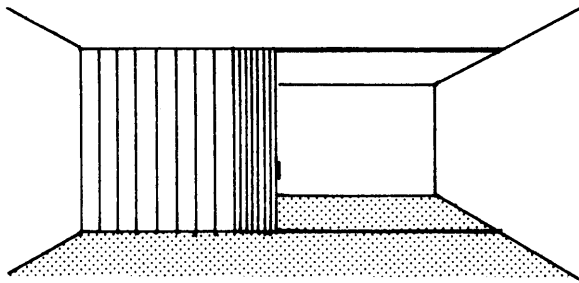

Operable Accordion Wall

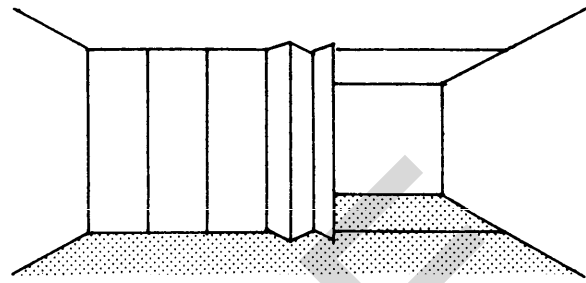

Operable Folding Panel Wall

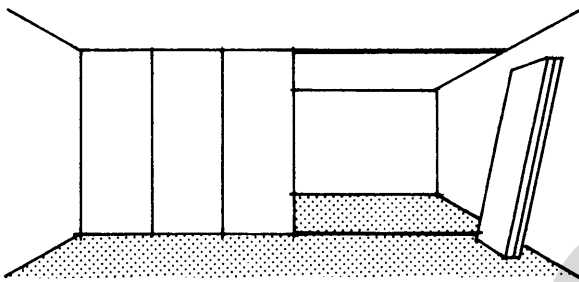

Portable Panel

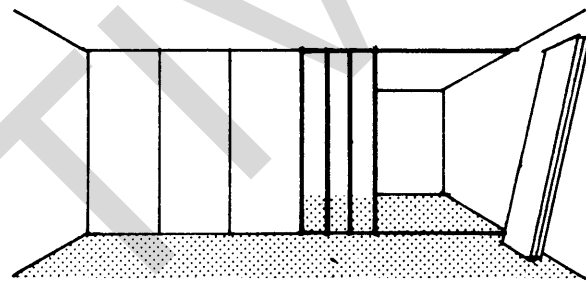

Movable Stud and Facing Panel Wall

Figure 3-8 Changeable Wall Systems

Table 3-2 Comparative Cost and Flexibility of Wall Systems

PARTITION TYPE	Relative Cost	CHANGE FREQUENCY			
		Hourly	Daily	Monthly	Yearly
Fixed (non-load bearing) 6" Concrete Block or 5" Wood Stud & Plaster	1	No	No	No	Yes
Movable	1.8	No	No	Possible	Yes
Accordion	2.6	Yes	Yes	Yes	Yes
Portable	3.2	No	Possible	Yes	Yes
Folding Panel	5.4	Yes	Yes	Yes	Yes

GENERAL DESIGN CONSIDERATIONS

DG 1110-3-112 May 1979

3-4 BUILDING DESIGN (cont'd)

(2) Doorways. Doorways to instructional spaces should be recessed where possible, and open in the direction of exit as shown in Figure 3-9. This eliminates doors which may open into and impede traffic flows, however, sufficient clearances must be provided so that persons in wheelchairs can reach and pull the door open. Frequently used doors to habitable spaces (including toilet rooms) should have wire or tempered glass vision panels to allow users to see persons approaching the door from the opposite direction.

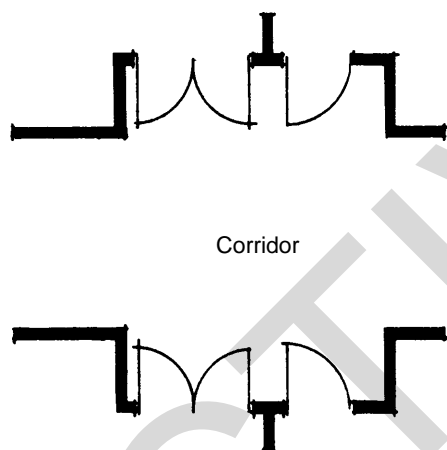

Figure 3-9 Recessed Room Exit

(3) Finish Materials. Interior finishes must be appropriate for the design function of the building and spaces. Selection of materials should be based on low maintenance qualities considering the anticipated use, life cost impact, fire and other safety requirements. Floor coverings should be easily maintained, durable and non-allergenic. They should contribute to sound control and provide a comfortable work surface. Unless otherwise specified, wall-to-wall carpeting should be provided in most areas except corridors, shops, toilets, storage areas, laboratories and vending areas. The color, texture and pattern of materials should complement the overall building design. Native (local) materials should be used to the greatest extent practicable. Long-life materials such as stones, tiles, woods, plastics and vinyls should be selected to provide attractive colors, textures and patterns that will not quickly become outdated. Painted surfaces and patterns are relatively easy and inexpensive to refurbish and can be kept fresh and up-to-date in appearance. Interior finishes must conform to the flame spread and smoke development standards contained in DoD Manual 4270.1-M and NFPA 101.

(4) Color. Use of color in Army facilities is limited to a practical number selected from Federal Standard 595A, Colors. General guidance for color selection is provided in TM 5-807-7, Colors for Buildings. Color should be used to stimulate human physical and emotional reactions and to enhance

3-4 BUILDING DESIGN (cont'd)

the overall functionality of the building. Use soft colors in study areas and consider brighter base colors and accents in casual seeing spaces. In critical seeing areas, glare, brilliant colors and great brightness differences, both in the lighting system and in the color of walls, floors, furnishings and equipment, should be avoided.

(5) Signage. Signage shall be designed as an overall building and site system and procured as part of the building construction. The system must be coordinated with signage required in conjunction with provisions for handicapped persons. Economy, ease of procurement and installation, and standardization of application are important considerations. The system should inhibit vandalism, but be flexible enough to enable the addition or deletion of information. The use of symbols instead of words is recommended. Where words are required, use a letterform such as Helvetica Medium, or other suitable letterforms. Letter sizes are designated by the height of the capital letters. Typical uses are 1 inch for locator signs, and 2 inches for directional and identification signs (and any signs where background lines are 3 inches apart). Signs should be located as close to eye-level as possible and be illuminated to provide adequate comprehension, either by room lighting or by special sign lighting avoiding reflection and glare. The building signage system should incorporate the types of signs described under the following headings:

(a) Facility Identifier Sign. This sign should be located in conjunction with the main entrance, oriented toward exterior pedestrian and vehicular traffic. It should identify the building number and the facility function (e.g., Education Center, etc.) and also indicate the hours of operation. Size of lettering and the exact location of the signs should be determined in each individual case in relation to the architectural design and local Facilities Engineer policy.

(b) Activity Locator Sign. This sign should be positioned in a prominent place for use upon entering the building and on each floor of a multi-story building. It must identify and locate building spaces, key activities and personnel and show emergency exits. The sign should also provide a description and/or plan of features for the physically handicapped.

(c) Identification Signs. These signs must identify restrictions, selected spaces, activities and personnel, and also reserved facilities such as for the physically handicapped. The most direct and economical way is by the use of symbols or pictographs. Use sign panels, approximately 6 inches square, for most identification purposes (toilets, phones, housekeeping closets, stairs, handicapped facilities, etc.) Use sign panels, approximately 12 inches square, for prohibitory signs (no entry, no smoking, etc.). When words and numbers are required as part of an individual space identification, use sign panels approximately 3 inches by 24 inches wall mounted next to doors on the side opposite the door hinge. A letterform approximately 2 inches in height, black on white where numbers are required and white on black where words are required, is recommended. The number of 3 inch x 24 inch sign panels for each space will depend upon how much information must be displayed. A symbol sign and a word-number sign are both shown in Figure 3-10.



Figure 3-10 Identification Signs

(d) Directional Signs. These signs can make use of the same sign panels as recommended under Identification Signs, using a black arrow in white panel above the white on black word panels as shown in Figure 3-11.



Figure 3-11 Directional Sign

(e) Notice Boards. Notice Boards help control clutter and can readily accommodate changing information pertaining to instruction schedules, text requirements, etc. They should be used adjacent to entries into individual shops, lecture rooms, seminar and classrooms, and elsewhere as appropriate. A general notice board should be located in the information registration area and in the student lounge. Simple notice boards can be created by providing a 3 foot to 5 foot wide field of a solid base color surmounted at the 6 1/2 foot level by a 6 inch white board with the word "Notices" in a 4 inch black letterform (such as Helvetica Medium). One or two narrow tack strips at the 6 foot and 4 foot levels should be provided as required for thumbtacking notices.

(6) Graphics. While mainly decorative, graphics may frequently incorporate floor numbers, directional indicators, safety markings, Army insignia, and so on. When professionally done, they can be most effective in livening up spaces and producing interest such as in large rooms or circulation spaces.

3-5 RELATED FURNISHINGS AND EQUIPMENT

Final selection of equipment and furnishings will be based on the items identified and data developed during the planning and programming process discussed in paragraph 2-6. During concept and final design, previous requirements and data must be reviewed and coordinated again with the installation. Data must then be updated using the *latest* mandatory source catalogs, and taking into account the pertinent selection factors and procurement support required.

a. SELECTION FACTORS.

(1) Appearance. Furniture is an integral part of the overall building design and must be closely coordinated with the selection of building colors and finish materials for consistency in appearance and quality. Clear relationship between the furnishings finish schedule and the building finish materials schedule should be evident. Similar attention should be given to the selection of equipment.

(2) Durability, Comfort, and Safety. Furnishings and equipment must be carefully selected to insure that the types chosen conform to standards of durability, comfort and safety appropriate for the uses they will receive. Being generally mobile, furniture and equipment items are subject to handling. Parts that receive the most wear should be replaceable, and finishes should sustain regular cleaning. Colors, textures, sizes, proportions, shapes and reflections are important comfort factors that should be considered. Furniture and equipment must withstand loading conditions without damage. Edges and surfaces should be smooth and rounded. Materials must be flame-retardant.

(3) Mobility and Interchangeability. Most furniture and equipment items should not be of a scale which would require more than two persons to relocate them, or be so complicated as to require an undue amount of time to assemble or disassemble. Whenever possible, choose multi-purpose furnishings and equipment which are suitable for a variety of needs and activities. Stackable and foldable items should be considered for reducing bulkiness in storage and transport where such requirements exist.

b. PROCUREMENT SUPPORT. Separate layouts and schedules will be developed to distinguish items which must be procured by the installation separately. Drawings and supporting data will be sufficient to facilitate procurement, and be in a format that can be readily understood by installation personnel who will be responsible for component placement and utilization after delivery. Placement plans, catalog illustrations, material and color samples together with procurement lists, source data and cost estimates should be developed as appropriate to accomplish this objective.

c. DELIVERY AND PLACEMENT. Once the procurement support material is complete, procurement must be scheduled to assure delivery upon completion of construction, otherwise beneficial use of the facility may be delayed. This is the responsibility of the installation. Delivery and placement of the items are extremely important considerations and should be *carefully managed* by the installation. Without such control, it will be difficult to assure quality, and execution of interior design intentions.

GENERAL DESIGN CONSIDERATIONS

DG 1110-3-112 May 1979

3-6 PROVISION OF USER INFORMATION

Records required upon completion of building projects are delineated in AR 415-10. Requirements for additional user information are established in ER 1110-345-700, Design Analysis. Design features which facilitate or aid functionality, housekeeping, etc., must be described and instructions prepared to supplement project completion records. The objective is to *identify how to best utilize the facility design* in a way that facilitates understanding by ACES Center personnel. The following outline indicates types of information that should be developed for this purpose.

a. SPECIAL CONSIDERATIONS.

- (1) Barrier-free design features for both handicapped and able-bodied persons.
- (2) Energy conservation features.
- (3) Occupational safety and health provisions.
- (4) Pollution control.

b. SITE DESIGN.

- (1) Utility service system.
- (2) Landscape features.

c. BUILDING DESIGN.

- (1) Functional features of space organization.
- ~~(2)~~ Floor load capacities and limitations.
- (3) Space flexibility and multi-use provisions.
- (4) Viewing positions and settings provided to enhance perception of design qualities and concepts.
- (5) Protective construction features for wind resistance, seismic events and fallout.
- (6) Sound and vibration controls.
- (7) Features of environmental control system; HVAC, lighting, communications, etc.
- (8) Fire protection system; detection alarm systems, evacuation routes, resistive construction and extinguishment systems.

3-6 PROVISION OF USER INFORMATION (cont'd)

(9) Security features; keying diagram, protective lighting, etc.

(10) Housekeeping and services supply, trash removal, storage, relamping, equipment repair, postal and engineer service, etc.

(11) Finish materials maintenance.

d. EQUIPMENT AND FURNITURE.

(1) Placement and flexibility.

(2) Storage and maintenance.

INACTIVE

4-1 GENERAL

This chapter describes individual staff, academic, vocational training and support spaces needed to accommodate the typical functions of ACES Centers. Functional uses and adjacency relationships are described; occupant loads and space allocations are identified; and typical functional layouts are provided. Space allocations and layouts are based on 5-foot modular dimensioning discussed in Chapter 3 under Functional Layout. At the end of the chapter is a summary of environmental support criteria applicable to each space.

4-2 STAFF SPACES

Staff spaces include offices for the director, administrators, clerks, typists, registrar and counselors.

a. DIRECTOR'S OFFICE

Use	For the Director who oversees the ACES Center operation and holds frequent conferences with staff and visitors.
Occupant Load	1 staff
Space allocation	200 NASF
Adjacency relationships	Locate adjacent to Clerks, Typists and Administrators with indirect but unobstructed access to Counselors.
Layout	See Figure 4-1.

- 1. Director's Desk and Chair
- 2. Bookcase credenza
- 3. File cabinet
- 4. Visitor chair

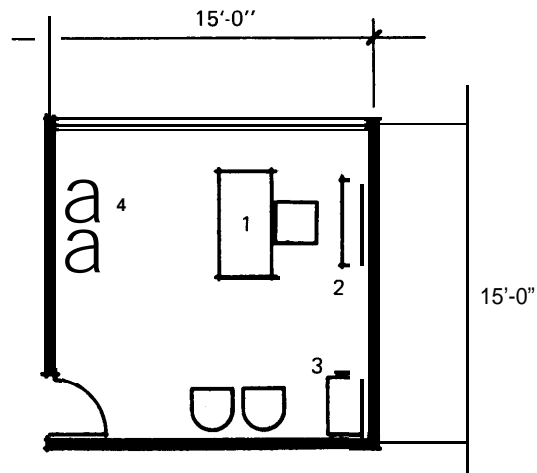

Figure 4-1 Director's Office

INDIVIDUAL SPACE CRITERIA

DG 1110-3-112 May 1979

4-2 STAFF SPACES (cont'd)

b. ADMINISTRATOR OFFICES

Use	For Administrators who oversee various segments of the instructional program and hold frequent conferences with contracted instructors and staff.
Occupant load	1 staff per office
Space allocation	Offices 150 NASF per administrator
Adjacency relationships	Locate Administrators near the Director's Office
Layout	See Figure 4-2

- 1. Administrator's desk and chair
- 2. Bookcase or credenza
- 3. File cabinet
- 4. Visitor chair
- 5. Chalk/tack surface

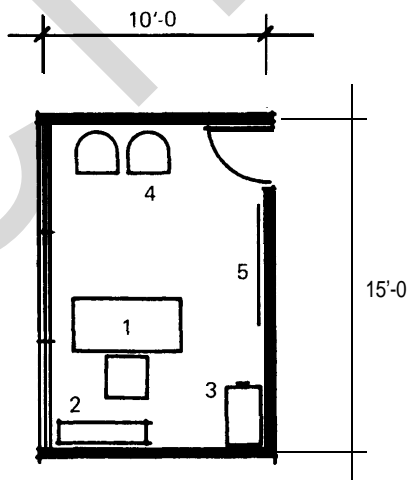

Figure 4-2 Administrator's Office

4-2 STAFF SPACES (cont'd)

c. INFORMATION/REGISTRATION/CLERK/TYPIST SPACE

Use	For Clerks who assist in administrative matters such as procurement, funds control, and in keeping of records; for Typists who provide typing and secretarial services for the entire staff; and for the Registrar who provides registration and information services. A contiguous space is required for visitor/student information. Also a separate space is required for storage of office forms and equipment.	
Occupant load	1 staff per office	
Space allocation	Offices	100 NASF per Clerk 75 NASF per Typist
	Registrar	100 NASF
	Information/Reg.	150 SF (min)
	Storage	75 SF (min)
Adjacency relationships	Locate Clerk/Typist spaces adjacent to Director/Administrator Offices. Locate Registrar and Information spaces adjacent to the main entrance for visitor convenience and visual control. Storage should be adjacent although it may be segmented to other parts of the facility where needs for this type of storage exist. Easy access should also be available to Training Aids Preparation and the Receiving Room.	
Layout	See Figure 4-3.	

INDIVIDUAL SPACE CRITERIA

DG 1110-3-112 May 1979

4-2 STAFF SPACES (cont'd)

- | | |
|---------------------------|--|
| 1. Typist Desk and Chair | 7. Registrar's Desk and Chair |
| 2. Typing Credenza | 8. Counter w/computer terminal or file |
| 3. File Cabinet | 9. Counter Chairs |
| 4. Bookcase | 10. Tack surface or Notice Board |
| 5. Clerk's Desk and Chair | 11. Display and Trophy Cabinet |
| 6. Visitor Chair | 12. Shelving |

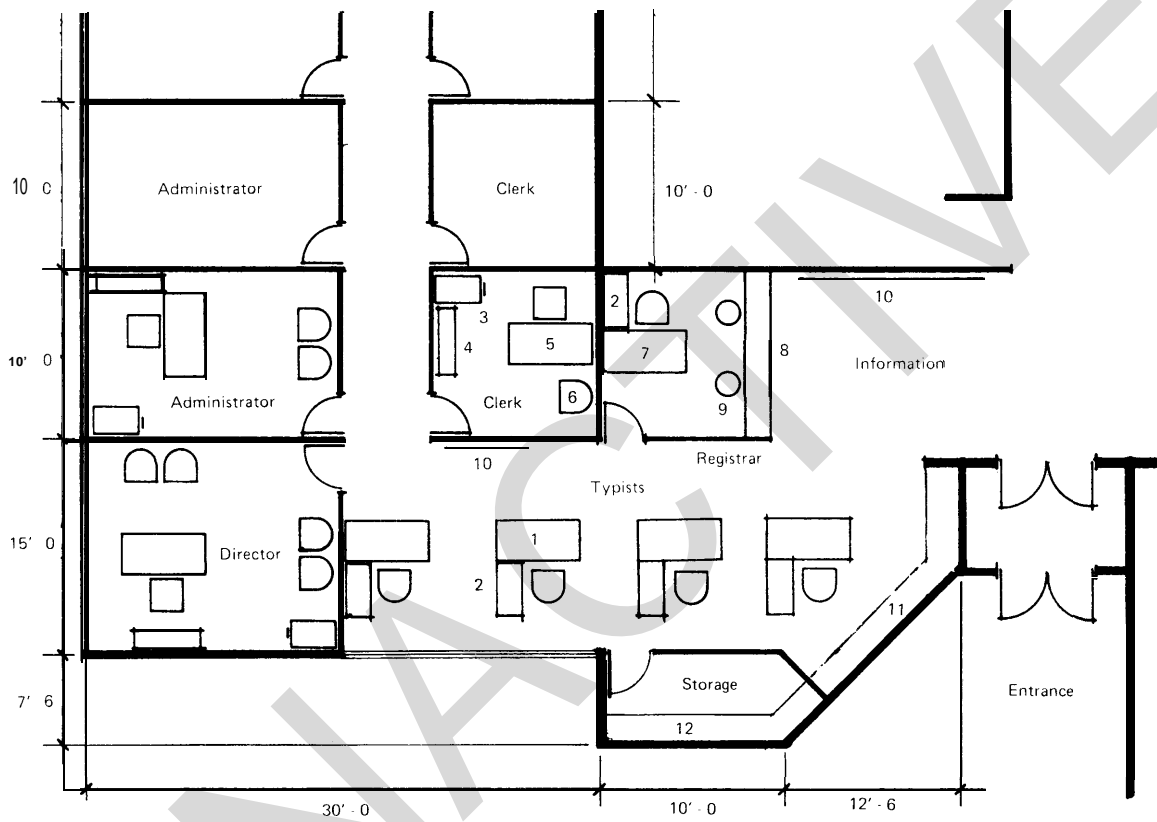

Figure 4-3 Information/Registration/Clerk/Typist Space

4-2 STAFF SPACES (cont'd)

d. COUNSELOR OFFICES

Use	For Counselors who assist personnel develop effective continuing education plans. A separate space for reference and conference is normally required.
Occupant load	1 staff per office
Space allocation	Offices 100 NASF per counselor; 1 to 10 75 NASF per counselor; 11 and above
Adjacency Relationships	Locate Counselors near the Information/Registration space with indirect but unobstructed access to the Director's Office. Reference room should be adjacent.
Layout	See Figure 4-4.

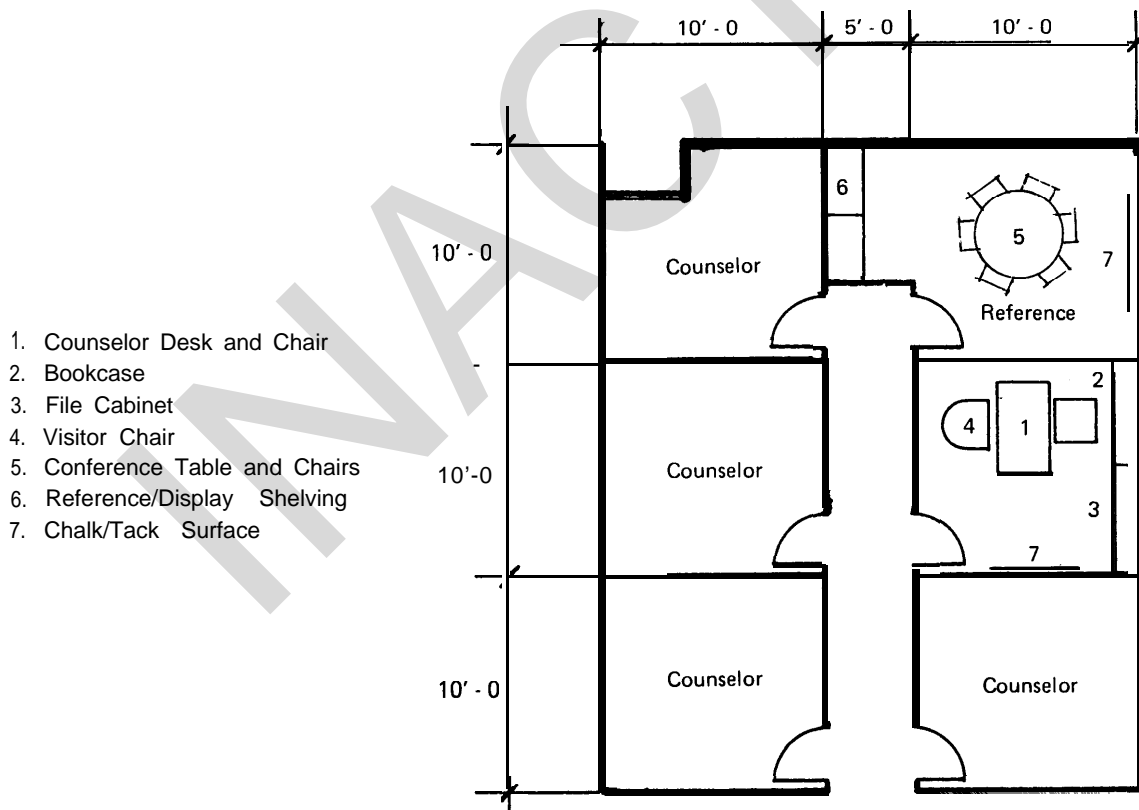

Figure 4-4 Counselor Offices

INDIVIDUAL SPACE CRITERIA

DG 1110-3-112 May 1979

4-3 ACADEMIC SPACES

Academic spaces include classrooms, lecture rooms, seminar rooms, MOS library, self-paced instruction room, laboratories, testing room and rehearsal/recording studio.

a. CLASSROOM

Use	For general purpose classes.
Occupant load	24 students, 1 instructor
Space allocation	750 NASF
Adjacency Relationships	Locate together with other academic spaces.
Layout	See Figure 4-5.

1. TV Monitor
2. Instructor's Table and Chair
3. Student Table and Chair
4. Tack Board
5. Chalkboard

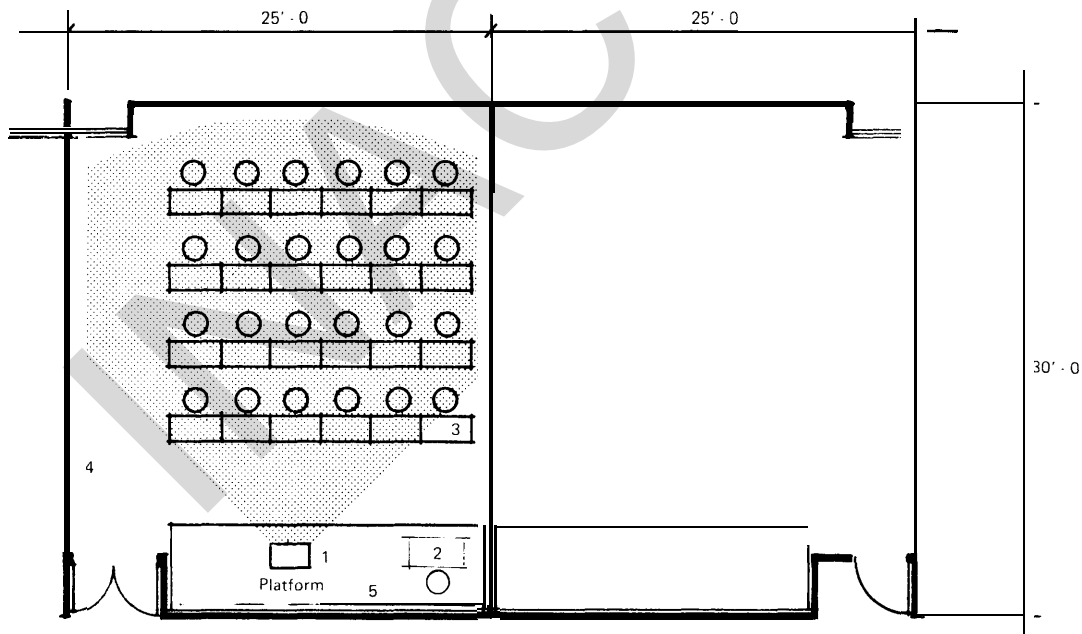

Figure 4-5 Classroom

4-3 ACADEMIC SPACES (cont'd)

b. LECTURE ROOM

Use	For lectures, testing and assemblies, educational and recreational motion pictures, and public meetings.
Occupant load	52 students, 1 instructor
Space allocation	1500 NASF
Adjacency relationships	Locate near classrooms and preferably near main entrance. Should be easily found by persons unfamiliar with the ACES Center. An adjacent lounge would be helpful in handling crowds entering and/or leaving, especially when used for recreation or public meetings.
Layout	See Figure 4-6

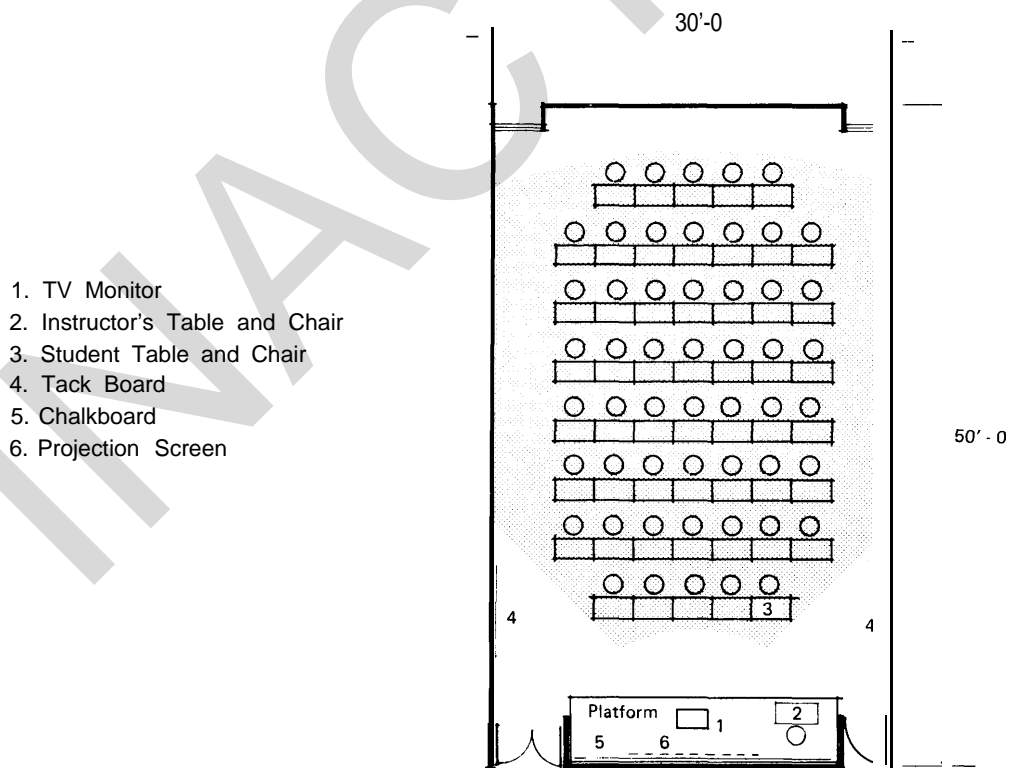

Figure 4-6 Lecture Room

INDIVIDUAL SPACE CRITERIA

DG 1110-3-112 May 1979

4-3 ACADEMIC SPACES (cont'd)

c. SEMINAR ROOM

Use	For seminars, small classes and conferences.
Occupant load	12 students, 1 instructor
Space allocation	375 NASF
Adjacency relationships	Locate in proximity of other academic spaces. Maybe grouped or dispersed
Layout	See Figure 4-7

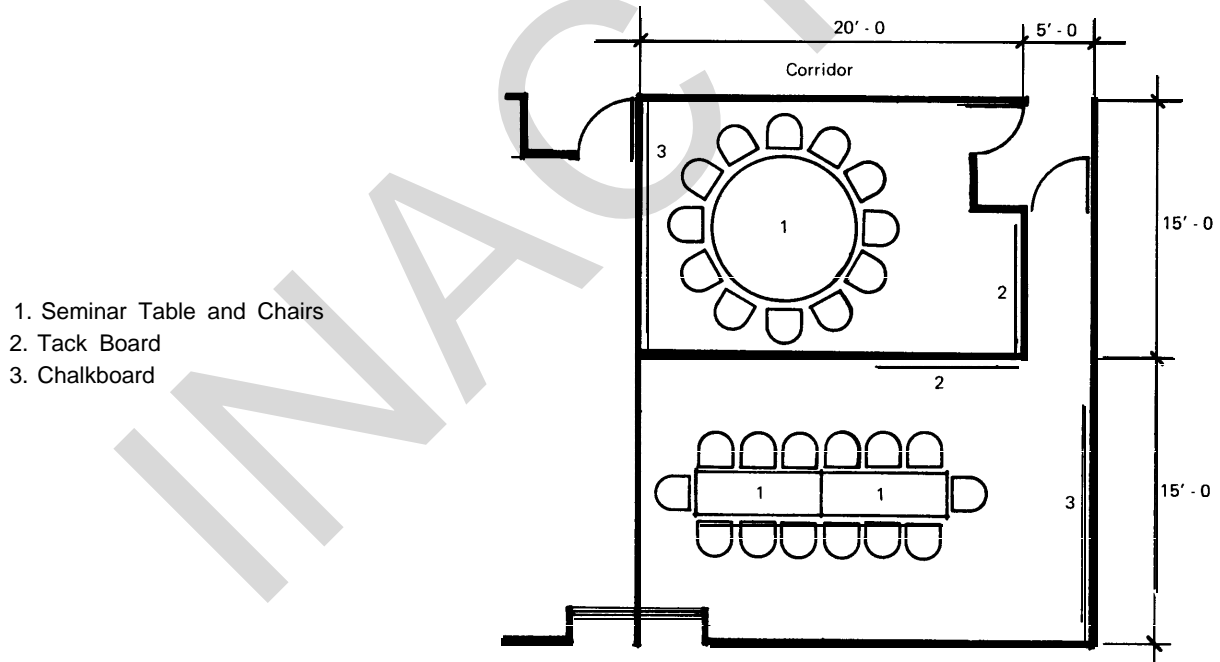

Figure 4-7 Seminar Rooms

4-3 ACADEMIC SPACES (cont'd)

d. MOS LIBRARY

Use	For storage and use of MOS-related material (approximately 10,000 volumes). The library is operated by staff on a schedule basis. In some cases, an MOS librarian may be authorized who would then also occupy the space.
Occupant load	8 students, 1 staff
Space allocation	750 NASF
Adjacency relationships	Adjacent with direct access to Self-Paced Instruction room. Central location to academic spaces is desirable.
Layout	See Figure 4-8

1. Staff Desk and Chair
2. Reading Table and Chairs
3. Reading Carrel and Chair
4. Bookstack
5. Tack Board

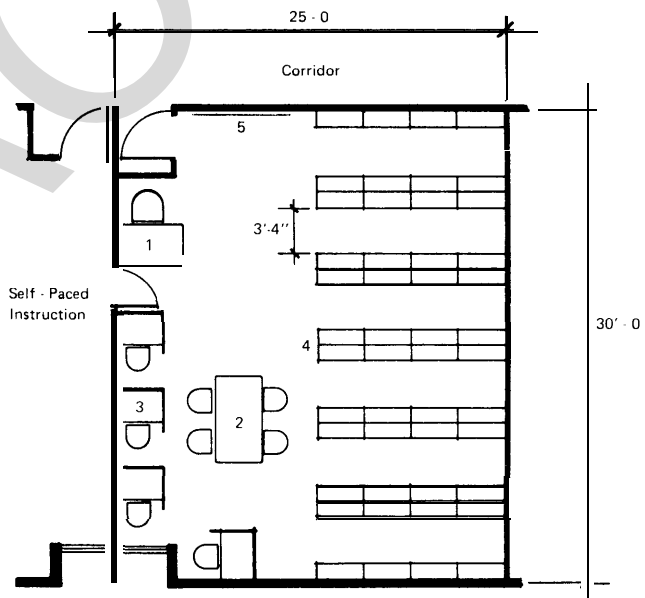

Figure 4-8 MOS Library

INDIVIDUAL SPACE CRITERIA

DG 1110-3-112 May 1979

4-3 ACADEMIC SPACES (cont'd)

e. SELF-PACED INSTRUCTION

Use	For individual study of MOS-related and other educational material using AV aids such as audio cassettes with synchronized film strips, slides or videotapes.
Occupant load	19 students, 1 staff
Space allocation	750 NASF
Adjacency relationships	Locate adjacent to the MOS Library
Layout	See Figure 4-9

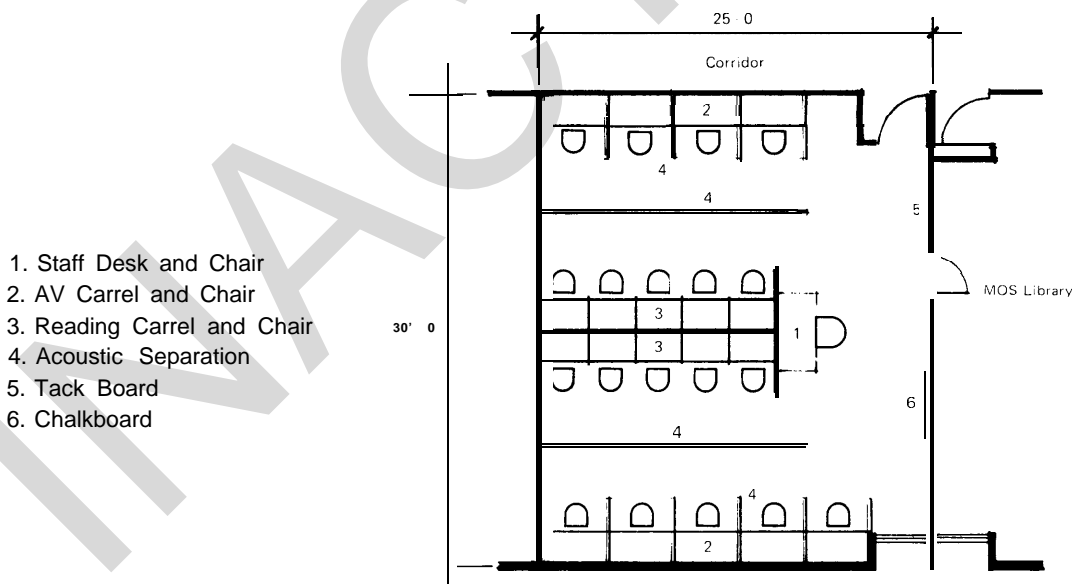

Figure 4-9 Self-Paced Instruction

4-3 ACADEMIC SPACES (cont'd)

f. LANGUAGE LABORATORY

Use	For language instruction where students listen to foreign language recordings, make their own recordings, practice speaking and carry out exercises. Separate spaces are required for storage and taping.								
Occupational load	21 students, 1 instructor								
Space allocation	<table border="0"> <tr> <td>Laboratory</td> <td>600 SF</td> </tr> <tr> <td>Storage</td> <td>95 SF</td> </tr> <tr> <td>Taping</td> <td>55 SF</td> </tr> <tr> <td>Total</td> <td>750 NASF</td> </tr> </table>	Laboratory	600 SF	Storage	95 SF	Taping	55 SF	Total	750 NASF
Laboratory	600 SF								
Storage	95 SF								
Taping	55 SF								
Total	750 NASF								
Adjacency relationships	Locate in proximity of other academic spaces. Rooms for taping and storage should open directly into laboratory.								
Layout	See Figure 4-10								

1. Instructor's Desk (with TV Monitor) and Chair
2. AV Carrel (with Division Panel) and Chair
3. Tack Board
4. Chalkboard
5. Projection Screen
6. Tape Storage
7. Shelving
8. Table and Chair

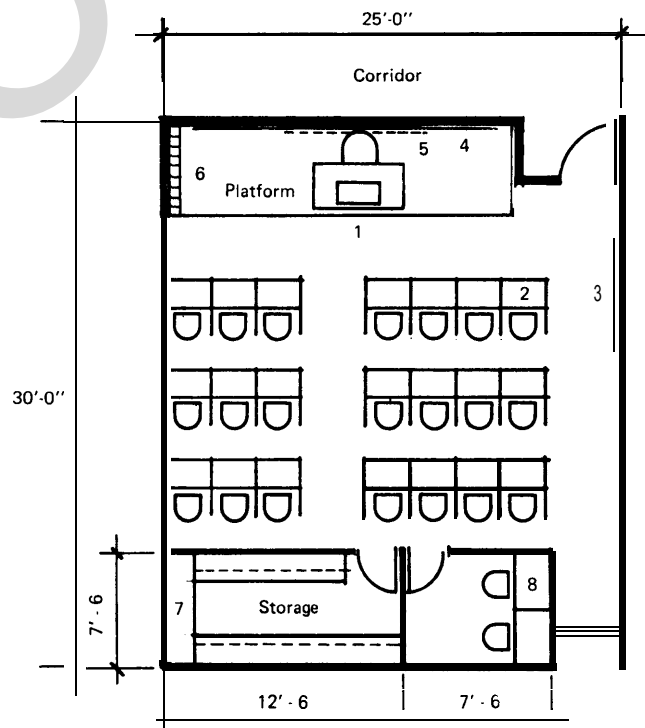

Figure 4-10 Language Laboratory

INDIVIDUAL SPACE CRITERIA

DG 1110-3-112 May 1979

4-3 ACADEMIC SPACES (cont'd)

g. SCIENCE LABORATORY

Use	For instruction and experimentation in physics, biology and chemistry. Separate spaces are required for special projects, preparation of materials, and storage.										
Occupant load	24 students, 1 instructor										
Space allocation	<table border="0" style="width: 100%;"> <tr> <td>Laboratory</td> <td style="text-align: right;">1,050 SF</td> </tr> <tr> <td>Special Projects</td> <td style="text-align: right;">225 SF</td> </tr> <tr> <td>Preparation</td> <td style="text-align: right;">125 SF</td> </tr> <tr> <td>Storage</td> <td style="text-align: right;">100 SF</td> </tr> <tr> <td style="border-top: 1px solid black;">Total</td> <td style="text-align: right; border-top: 1px solid black;">1,500 NASF</td> </tr> </table>	Laboratory	1,050 SF	Special Projects	225 SF	Preparation	125 SF	Storage	100 SF	Total	1,500 NASF
Laboratory	1,050 SF										
Special Projects	225 SF										
Preparation	125 SF										
Storage	100 SF										
Total	1,500 NASF										
Adjacency relationships	Locate in proximity of other academic spaces. Rooms for special projects, preparation, and storage should open directly into the laboratory.										
Layout	See Figure 4-11										

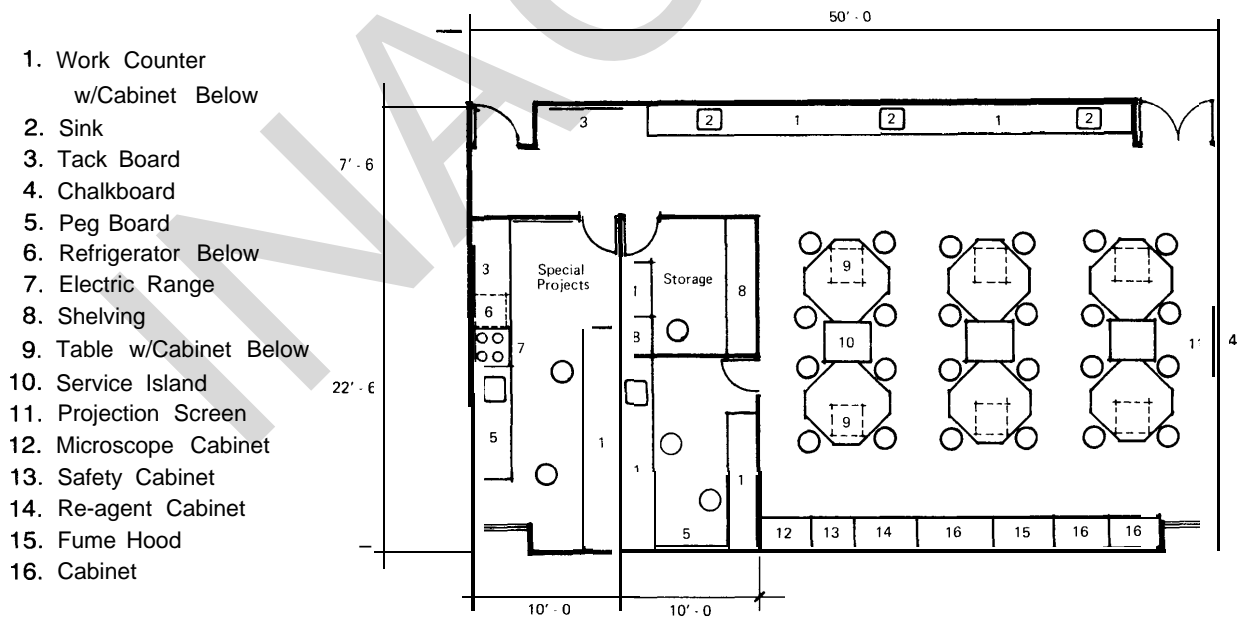

Figure 4-11 Science Laboratory

4-3 ACADEMIC SPACES (cont'd)

h. TESTING ROOM

Use	For testing and general purpose classes. Should be divisible into two classroom spaces. Separate spaces are required for observation and grading of examinations, and storage of extra tables and chairs required for classroom use.										
Occupant load	35 students, 2 instructors for testing 48 students, 2 instructors for classes										
Space allocation	<table border="0"> <tr> <td>Testing Room</td> <td style="text-align: right;">1,625 SF</td> </tr> <tr> <td>Observation/Evaluation</td> <td style="text-align: right;">150 SF</td> </tr> <tr> <td>Secure storage</td> <td style="text-align: right;">55 SF</td> </tr> <tr> <td>Furniture storage</td> <td style="text-align: right;">75 SF</td> </tr> <tr> <td style="border-top: 1px solid black;">Total</td> <td style="text-align: right; border-top: 1px solid black;">1,905 NASF</td> </tr> </table>	Testing Room	1,625 SF	Observation/Evaluation	150 SF	Secure storage	55 SF	Furniture storage	75 SF	Total	1,905 NASF
Testing Room	1,625 SF										
Observation/Evaluation	150 SF										
Secure storage	55 SF										
Furniture storage	75 SF										
Total	1,905 NASF										
Adjacency relationships	Locate near to classrooms and lecture room. Spaces for observation and storage should open directly into the testing room.										
Layout	See Figure 4-12										

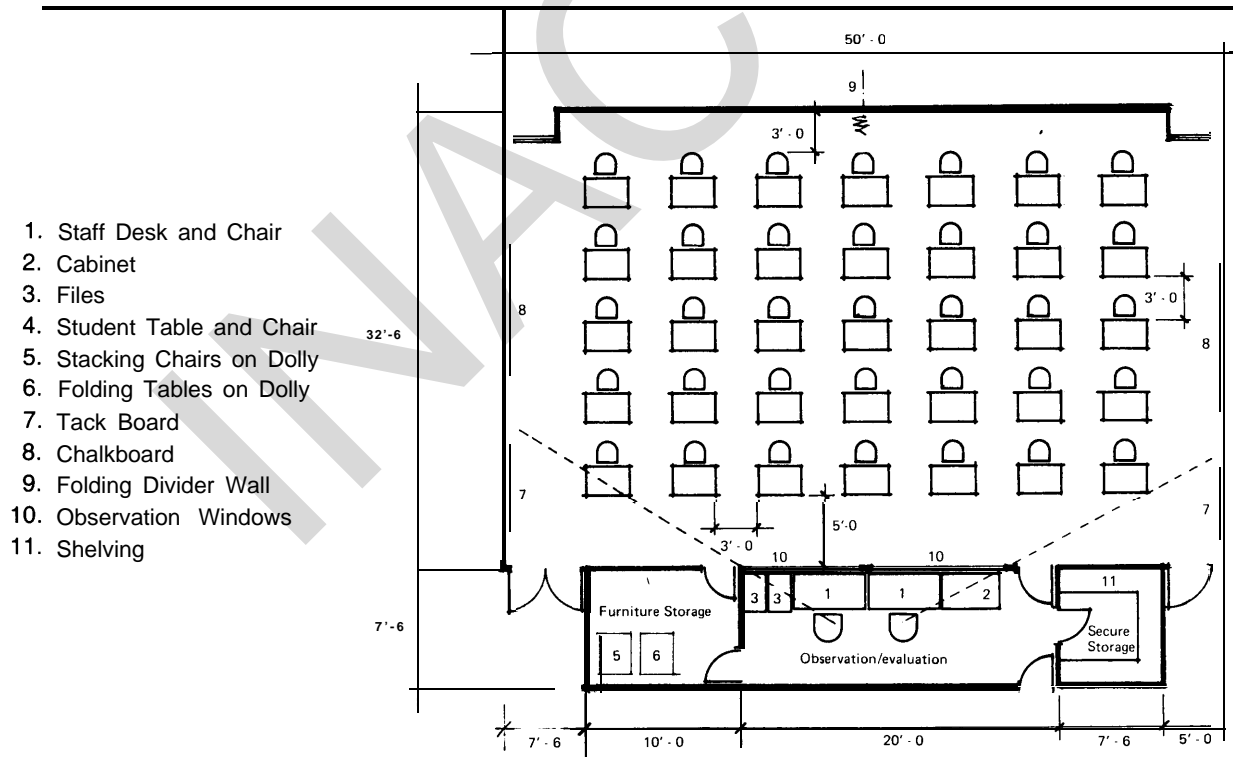

Figure 4-12 Testing Room

INDIVIDUAL SPACE CRITERIA

DG 1110-3-112 May 1979

4-3 ACADEMIC SPACES (cont'd)

i. REHEARSAL/RECORDING STUDIO

Use	For rehearsals of lectures and demonstrations as well as for taping lectures for video presentation. May also be used for seminars.
Occupant load	6 persons
Space allocation	375 NASF
Adjacency relationships	Locate centrally to the academic area and near to lecture and seminar areas.
Layout	See Figure 4-13

1. Instructor's Table (or lecturn) with AV Controls
2. TV Monitor and Recorder
3. Tack Board
4. Chalkboard
5. Projection Screen
6. Projector/TV Camera
7. Table and Chair
8. Sound Lock Door

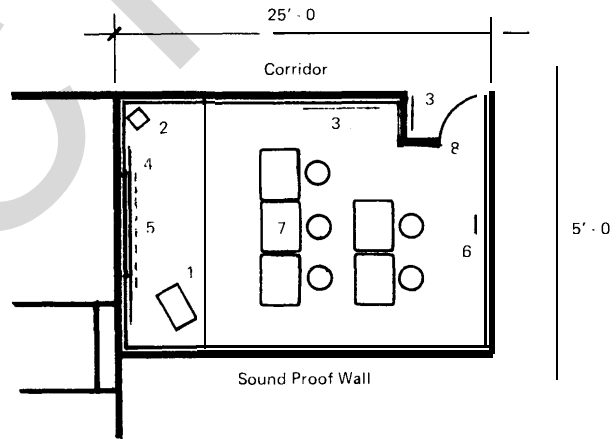

Figure 4-13 Rehearsal/Recording Studio

4-4 VOCATIONAL TRAINING SPACES

Vocational training spaces include shops for the following types of training:

Heating/Refrigeration/Air Conditioning

Construction Electrician

Communications/Industrial Electronics

Masonry

Carpentry

Plumbing

Diesel Mechanics

Auto Mechanics

Welding

Auto Body Repair

Small Engine Repair

Other courses may be offered, and each building project should reflect the specific requirements of the local program. Also, layouts must be verified by the using installation to assure that they conform to current programs and technologies. Laboratory ceiling heights should generally provide 16' minimum clearance, and each laboratory should have access to an outside service area. Vocational training shops require ample storage. The areas allocated to storage in this guide may be revised if necessary.

4-4 VOCATIONAL TRAINING SPACES (cont'd)

a. HEATING/REFRIGERATION/AIR CONDITIONING SHOP

Use	For lectures, demonstrations and laboratory experimentation with heating, air-conditioning and refrigeration units.
Occupant load	20 persons
Space allocation	2200 NASF
Adjacency relationships	Locate near to Plumbing Shop and Construction Electrician Shop with personnel access to exterior.
Layout	See Figure 4-14

b. CONSTRUCTION ELECTRICIAN SHOP

Use	For lectures, demonstrations and laboratory experimentation with electrical wiring systems related to building construction. Separate spaces are required for secure storage of tools and supply parts and for conferences.	
Occupant load	20 persons	
Space allocation	Shop	2,000 SF
	Tool Storage	150 SF
	Supply Parts	150 SF
	Conference	150 SF
	Total	2,450 NASF
Adjacency relationships	Locate near to Communications/Industrial Electronics Shop and the Heating/Refrigeration/Air Conditioning Shop with personnel and service access to exterior service area. Locate tool storage, supply parts, and conference rooms near entrance and open directly into shop.	
Layout	See Figure 4-15	

4-4 VOCATIONAL TRAINING SPACES (cont'd)

- | | |
|---|---|
| <ol style="list-style-type: none"> 1. Test Stand 2. Combined Forced Air & Hydronic Heating Training Units 3. Heating Test Equipment Package 4. Gas Fired Forced Air Control Board 5. Oil Fired Forced Air Control Board 6. Automobile Air Conditioner Training Unit 7. Cooling Tower Build-up Unit 8. Automobile Air Conditioner Training Unit 9. Oil Burner Climate Control Trainer 10. Gas Burner Climate Control Trainer 11. Refrigeration and Air Conditioning Test Equipment Package 12. Medium Commercial Multiple Evaporator Build-up Unit 13. Medium Commercial-Forced Convection Evaporator-Open Type Compressor Build-up Unit 14. Medium Commercial-Forced Convection Evaporator-Semi-Hermetic 15. Commercial Freezer-Electric Defrost Build-up Unit 16. Light Commercial Freezer-Air Conditioner Build-up Unit | <ol style="list-style-type: none"> 17. Medium Commercial Forced Convection Evaporator Build-up Unit 18. Light Commercial Forced Convection Evaporator Build-up Unit 19. Light Commercial-Gravity Evaporator Build-up Unit 20. Domestic Refrigeration Trainer Double Evaporation Build-up Unit 21. Air Conditioner Build-up Unit 22. Domestic Refrigeration Trainer Single Evaporator Build-up Unit 23. Industrial Refrigeration Trainer 24. Refrigeration and Air Conditioning Training Units 25. Single Phase Compressor Control Board 26. Refrigeration and Air Conditioning Training Units—Heat Pump Operation 27. Work Bench 28. Work Station 29. Table 30. Chalk/Tack Surfaces 31. Cabinet w/sink |
|---|---|

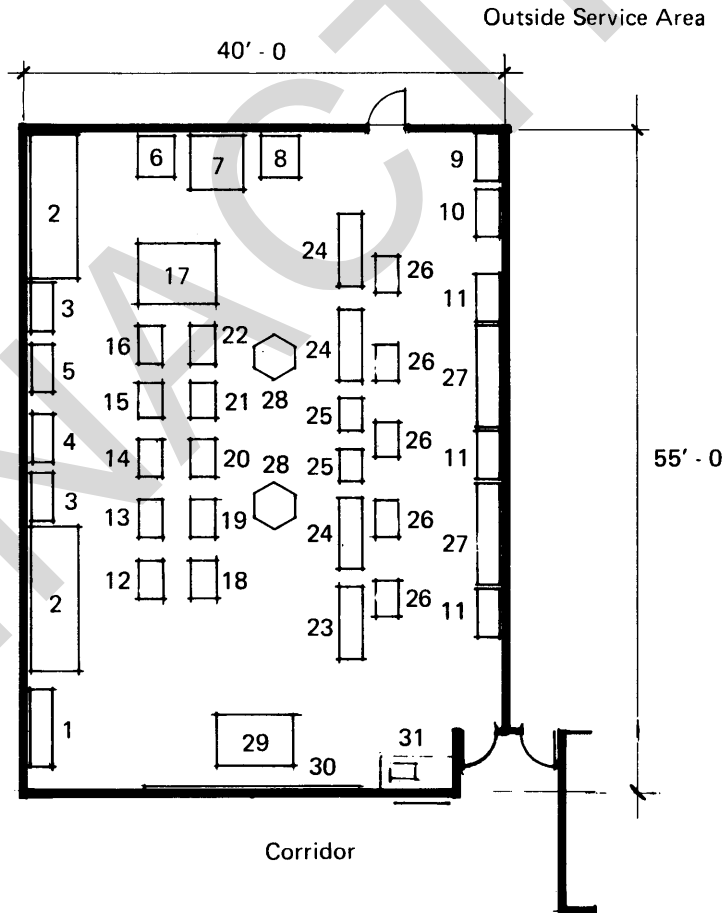

Figure 4-14 Heating/Refrigeration/Air Conditioning Shop

INDIVIDUAL SPACE CRITERIA

DG 1110-3-112 May 1979

4-4 VOCATIONAL TRAINING SPACES (cont'd)

- | | |
|-------------------------------------|---------------------------------|
| 1. Residential Wiring Trainer | 9. Overhead Door |
| 2. Metal bench | 10. Divider Screens |
| 3. Electric Wiring Trainer | 11. Conference Table and Chairs |
| 4. Electric Test Bench | 12. Chalkboard |
| 5. Soldering Bench | 13. Tack Board |
| 6. Wall Assembly Unit | 14. Tool Storage Cabinet |
| 7. Motor Control Wiring Unit | 15. Industrial Shelving |
| 8. AC Wiring and Lighting Simulator | |

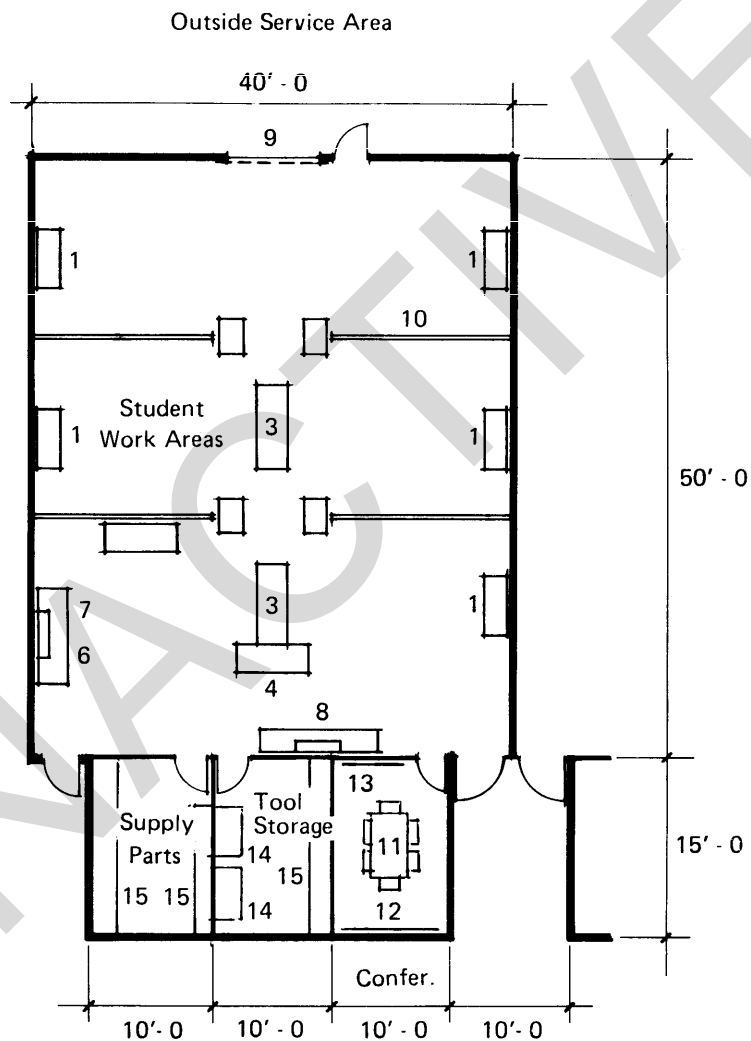

Figure 4-15 Construction Electrician Shop

4-4 VOCATIONAL TRAINING SPACES (cont'd)

c. COMMUNICATION/INDUSTRIAL ELECTRONICS SHOP

Use	For lectures, demonstrations and laboratory experimentation with basic communications, electrical and electronic systems, and motor machines. Separate spaces are required for secure storage of tools, general storage and for conferences.
Occupant load	20 persons
Space allocation	Shop 2,000 SF Tool Storage 150 SF General Storage 225 SF Conference 150 SF Total 2,525 SF
Adjacency relationships	Locate near Construction Electrician Shop with personnel and service access to exterior service area. Locate storage and conference rooms near entrance and open directly into shop.
Layout	See Figure 4-16

INDIVIDUAL SPACE CRITERIA

DG 1110-3-112 May 1979

4-4 VOCATIONAL TRAINING SPACES (cont'd)

- | | |
|-------------------------------------|---|
| 1. Electrical Benches | 15. Motor Control Units |
| 2. Basic Electricity Trainers | 16. Mobile Console |
| 3. Electricity-Electronics Trainers | 17. Tool Storage |
| 4. Power Tunnels | 18. Synchronizing Switch/Circuit Breakers |
| 5. 5" V.I.Z. Oscilloscope | 19. Three Phase Synchronous Motor Starter |
| 6. Electrical Wiring Tunnel | 20. AC Three Phase Starter |
| 7. Security Alarm Trainer | 21. AC Motor Starter |
| 8. AC Wiring and Lighting Simulator | 22. Overhead Door |
| 9. Residential Wiring Trainer | 23. Conference Table and Chairs |
| 10. Basic Studies of Transformers | 24. Chalkboard |
| 11. Single Phase DC Machines | 25. Tack Board |
| 12. Three Phase Machines | 26. Tool Storage Cabinet |
| 13. Specialized Machines | 27. Industrial Shelving |
| 14. Optional Accessories for Motors | |

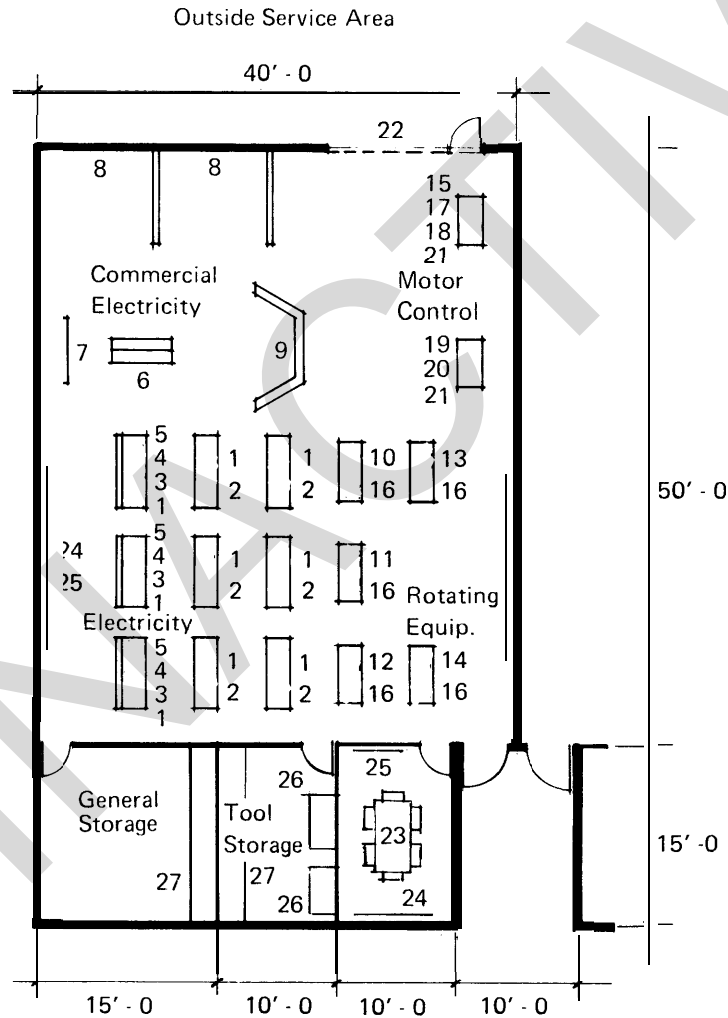

Figure 4-16 Communications/Industrial Electronic Shop

4-4 VOCATIONAL TRAINING SPACES (cont'd)

d. MASONRY SHOP

Use	For lectures, demonstrations and laboratory experience in masonry construction. Separate spaces are required for secure storage of tools, general storage, and for conferences.										
Occupant load	20 persons										
Space allocation	<table border="0" style="margin-left: 40px;"> <tr> <td>Shop</td> <td style="text-align: right;">3,250 SF</td> </tr> <tr> <td>Tool Storage</td> <td style="text-align: right;">375 SF</td> </tr> <tr> <td>General Storage</td> <td style="text-align: right;">375 SF</td> </tr> <tr> <td>Conference</td> <td style="text-align: right;"><u>150 SF</u></td> </tr> <tr> <td style="padding-left: 20px;">Total</td> <td style="text-align: right;">4,150 NASF</td> </tr> </table>	Shop	3,250 SF	Tool Storage	375 SF	General Storage	375 SF	Conference	<u>150 SF</u>	Total	4,150 NASF
Shop	3,250 SF										
Tool Storage	375 SF										
General Storage	375 SF										
Conference	<u>150 SF</u>										
Total	4,150 NASF										
Adjacency relationships	Locate in area of Carpentry, Plumbing and Heating/Refrigeration/Air-Conditioning Shops with personnel and service access to exterior. Locate storage and conference rooms near entrance and open directly into shop.										
Layout	See Figure 4-17										

INDIVIDUAL SPACE CRITERIA

DG 1110-3-112 May 1979

4-4 VOCATIONAL TRAINING SPACES (cont'd)

- | | |
|--------------------------|--------------------------------|
| 1. Mortar Box | 8. Divider Screens |
| 2. Wheelbarrows | 9. Conference Table and Chairs |
| 3. Brick and Tile Barrow | 10. Chalkboard |
| 4. Utility Hand Truck | 11. Tack Board |
| 5. Concrete Mixers | 12. Tool Storage Cabinet |
| 6. Mortar Mixers | 13. Industrial Shelving |
| 7. Overhead Door | |

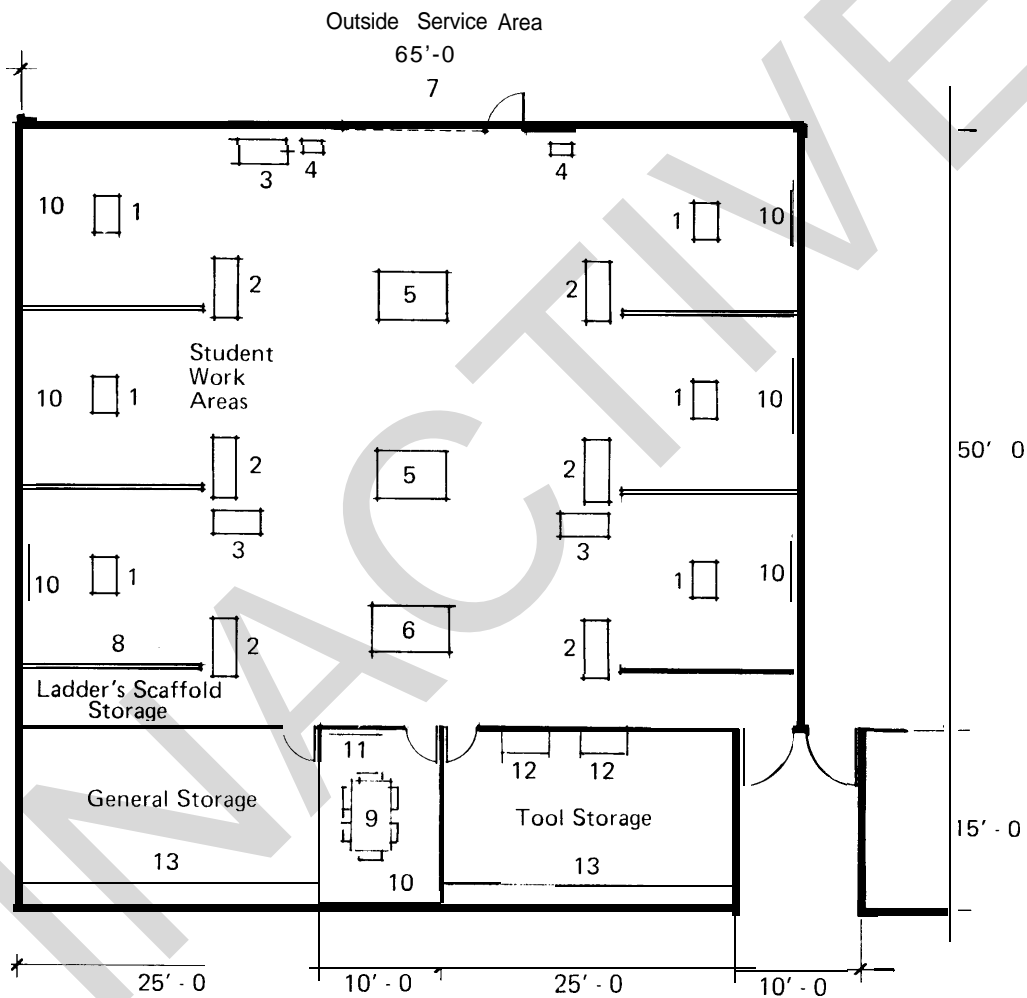

Figure 4-17 Masonry Shop

4-4 VOCATIONAL TRAINING SPACES (cont'd)

e. CARPENTRY SHOP

Use	For lectures, demonstrations and laboratory experience in rough and finish carpentry. Separate spaces are required for tool/supply storage, finish work, and conferences.	
Occupant load	20 persons	
Space allocation	Shop	4,000 SF
	Tool/Supply Storage	300 SF
	Finish room	225 SF
	Conference	150 SF
	Total	4,675 NASF
Adjacency relationships	Locate near Plumbing, Masonry and Heating/Refrigeration/Air-Conditioning Shops with personnel and service access to outside service area. Locate tool/supply, finish and conference rooms near entrance and open directly into shop.	
Layout	See Figure 4-18	

INDIVIDUAL SPACE CRITERIA

DG 1110-3-112 May 1979

4-4 VOCATIONAL TRAINING SPACES (cont'd)

- | | |
|----------------------------|---------------------------------|
| 1. Work Bench | 10. Overhead Door |
| 2. Tilting Arbor Saw | 11. Divider Screens |
| 3. Long-bed Jointer | 12. Conference Table and Chairs |
| 4. Four Station Work Bench | 13. Chalkboard |
| 5. Drill Press | 14. Tack Board |
| 6. Panel Saw | 15. Cabinet with Sink |
| 7. Sliding Door Cabinets | 16. Table |
| 8. Radial Saw | 17. Tool Storage Cabinet |
| 9. Lumber Rack | 18. Industrial Shelving |

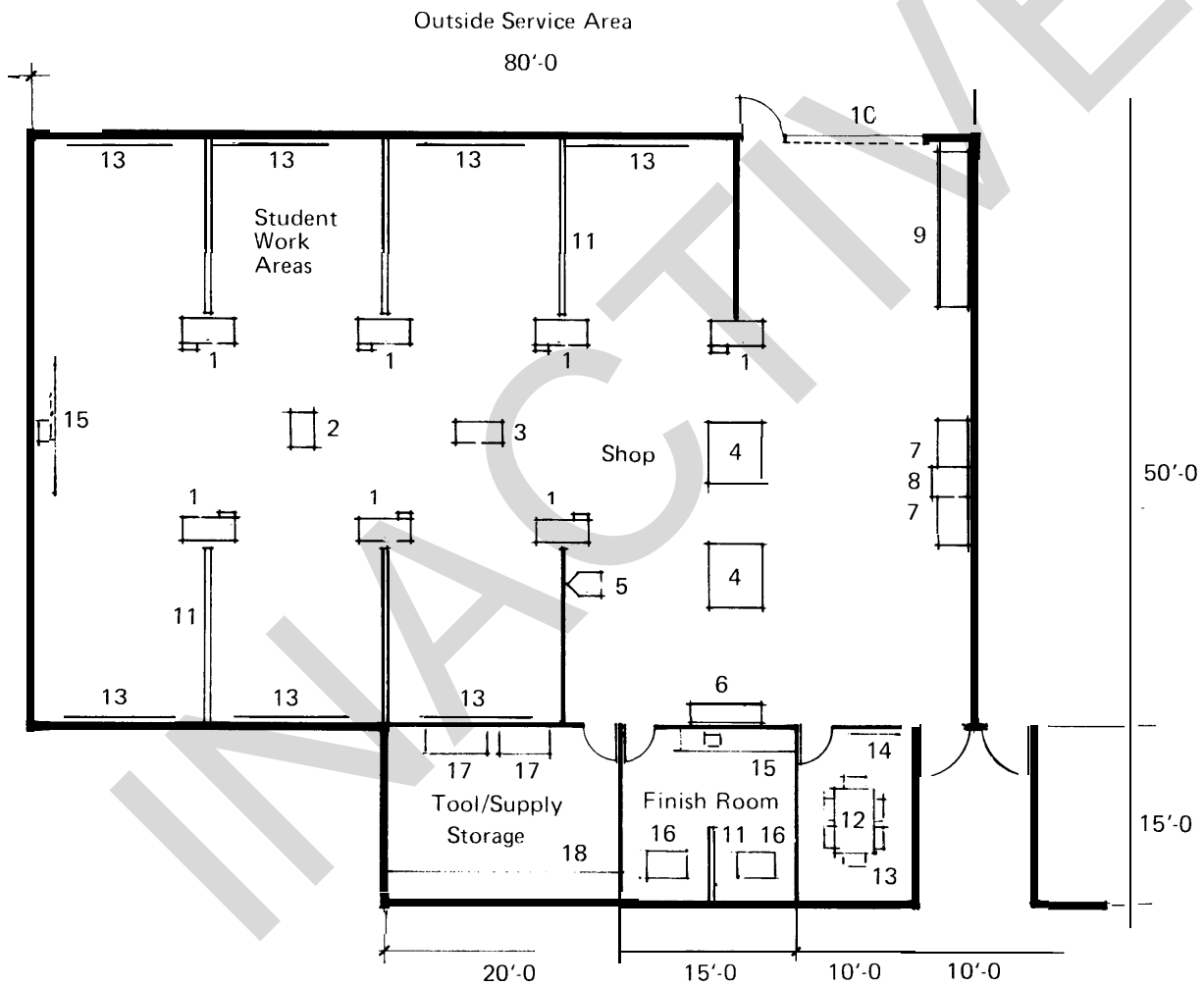

Figure 4-18 Carpentery Shop

4-4 VOCATIONAL TRAINING SPACES (cont'd)

f. PLUMBING SHOP

Use	For lectures, demonstrations and laboratory experience in plumbing. Separate spaces are required for secure storage of tools, general storage and for conferences.										
Occupant load	20 persons										
Space allocation	<table border="0" style="margin-left: 20px;"> <tr> <td>Shop</td> <td style="text-align: right;">2,000 SF</td> </tr> <tr> <td>General Storage</td> <td style="text-align: right;">150 SF</td> </tr> <tr> <td>Tool Storage</td> <td style="text-align: right;">150 SF</td> </tr> <tr> <td>Conference</td> <td style="text-align: right;">150 SF</td> </tr> <tr> <td style="border-top: 1px solid black;">Total</td> <td style="text-align: right; border-top: 1px solid black;">2,450 NASF</td> </tr> </table>	Shop	2,000 SF	General Storage	150 SF	Tool Storage	150 SF	Conference	150 SF	Total	2,450 NASF
Shop	2,000 SF										
General Storage	150 SF										
Tool Storage	150 SF										
Conference	150 SF										
Total	2,450 NASF										
Adjacency relationships	Locate near Carpentry and Heating/Refrigeration/Air-conditioning Shops with service access to outside service area. Locate general storage, tool and conference rooms near entrance and open directly into shop.										
Layout	See Figure 4-19										

INDIVIDUAL SPACE CRITERIA

DG 1110-3-112 May 1979

4-4 VOCATIONAL TRAINING SPACES (cont'd)

- | | |
|------------------------------------|---------------------------------|
| 1. Portable Tri-stand Vise | 9. Metal and Scrap Rack |
| 2. Metal Porta-bench | 10. Overhead Door |
| 3. Pipe and Bolt Threading Machine | 11. Divider Screens |
| 4. Adjustable Pipe Support | 12. Conference Table and Chairs |
| 5. Parts Storage | 13. Chalkboard |
| 6. Wall Assembly Unit | 14. Tack Board |
| 7. Box and Pan Brakes | 15. Cabinet w/sink |
| 8. Hand Operated Rollers | 16. Tool Storage Cabinet |
| | 17. Industrial Shelving |

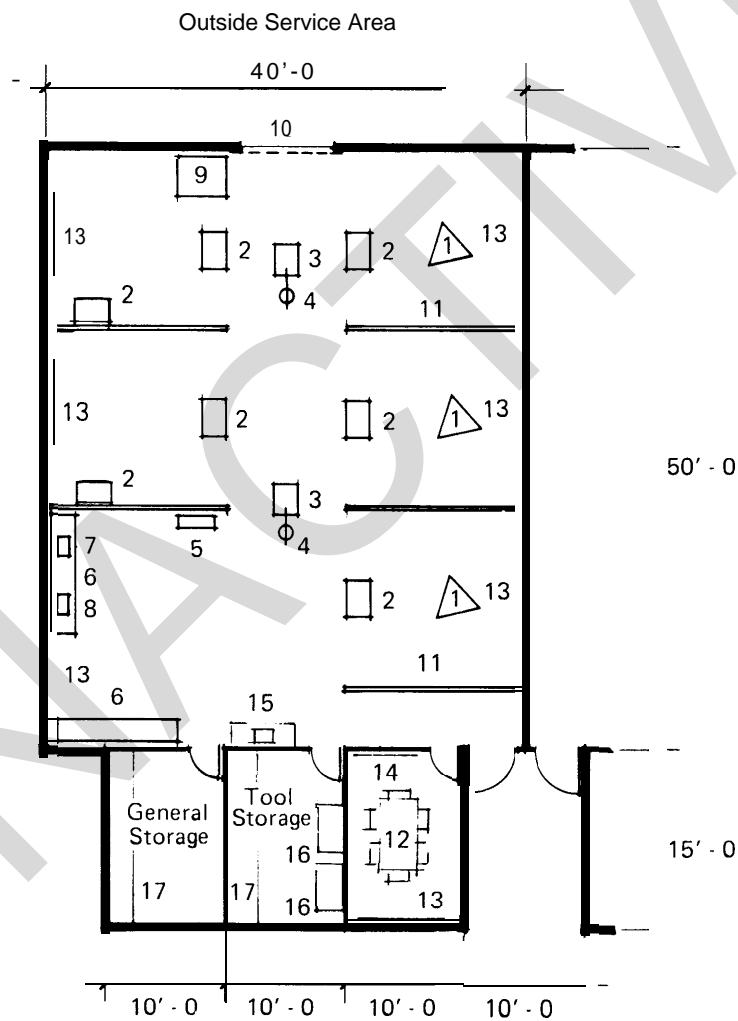

Figure 4-19 Plumbing Shop

4-4 VOCATIONAL TRAINING SPACES (cont'd)

g. DIESEL MECHANICS SHOP

Use	For lectures, demonstrations and laboratory experience in diesel mechanics. Separate spaces are required for storage of tools and for conferences.										
Occupant load	20 persons										
Space allocation	<table border="0" style="margin-left: 40px;"> <tr> <td>Shop</td> <td style="text-align: right;">2,800 SF</td> </tr> <tr> <td>Tool Storage</td> <td style="text-align: right;">225 SF</td> </tr> <tr> <td>Conference</td> <td style="text-align: right;">150 SF</td> </tr> <tr> <td></td> <td style="border-top: 1px solid black; text-align: right;">3,175 NASF</td> </tr> <tr> <td style="padding-left: 20px;">Total</td> <td></td> </tr> </table>	Shop	2,800 SF	Tool Storage	225 SF	Conference	150 SF		3,175 NASF	Total	
Shop	2,800 SF										
Tool Storage	225 SF										
Conference	150 SF										
	3,175 NASF										
Total											
Adjacency relationships	Locate near Auto Mechanics and Plumbing Shops with service and personnel access to outside service area. Locate tool storage and conference rooms near entrance and open directly into shop.										
Layout	See Figure 4-20										

INDIVIDUAL SPACE CRITERIA

DG 1110-3-112 May 1979

4-4 VOCATIONAL TRAINING SPACES (cont'd)

- | | |
|-------------------------------------|--|
| 1. Engine Service Module | 19. Storage Cabinet |
| 2. Instruction Module | 20. Wall Bench |
| 3. Battery Service Module | 21. Injector Floor Comparator |
| 4. Parts Module | 22. Bacharach Pump-Injector Test Package |
| 5. Wet Cleaning Module | 23. Hydraulic Training Unit |
| 6. Liquid Fuel Module | 24. Advanced Hydraulic Kit |
| 7. Dynamometer Module | 25. Goggle Cabinet |
| 8. Dry Cleaning Module | 26. File Cabinet/Reference Module |
| 9. Special Tool Module | 27. Tool Storage Cabinet |
| 10. Engine Work Stand | 28. Hardware Cabinet |
| 11. 2-station Work Bench | 29. Industrial Shelving |
| 12. Engine Work Stand w/accessories | 30. Machinists' Vise |
| 13. 7" Pedestal Grinder | 31. Overhead Door |
| 14. 15" Drill Press | 32. Cabinet w/sink |
| 15. 25 Ton Arbor Press | 33. Conference Table and Chairs |
| 16. Parts Washer | 34. Chaikboard |
| 17. Steam Cleaner | 35. Tack Board |
| 18. 4-station Work Bench | |

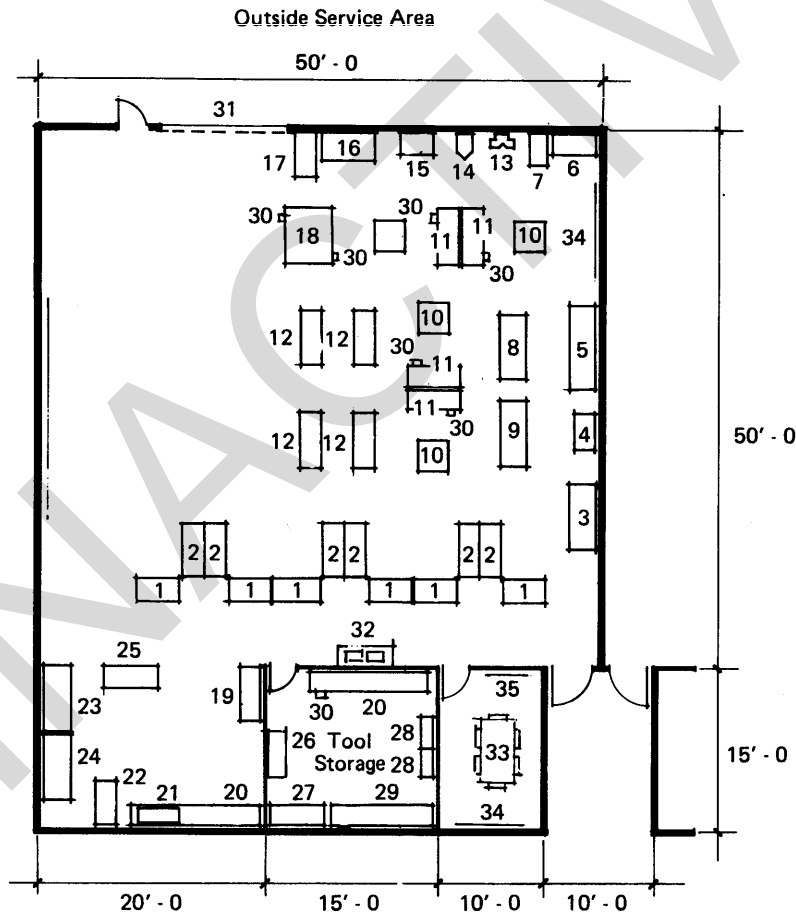

Figure 4-20 Diesel Mechanics Shop

4-4 VOCATIONAL TRAINING SPACES (cont'd)

h. AUTO MECHANICS SHOP

Use	For lectures, demonstrations and laboratory experience in auto mechanics. Separate spaces are required for general and tool storage and for conferences. Outside storage for approximately ten cars, fenced for security and screening, is also required.										
Occupant load	20 persons										
Space allocation	<table border="0" style="margin-left: 20px;"> <tr> <td>Shop</td> <td style="text-align: right;">5,250 SF</td> </tr> <tr> <td>Tool Storage</td> <td style="text-align: right;">225 SF</td> </tr> <tr> <td>General Storage</td> <td style="text-align: right;">225 SF</td> </tr> <tr> <td>Conference</td> <td style="text-align: right;"><u>150 SF</u></td> </tr> <tr> <td style="padding-left: 20px;">Total</td> <td style="text-align: right;">5,850 NASF</td> </tr> </table> <p style="margin-left: 20px;">Outside Auto Storage 2000 SF (approximately)</p>	Shop	5,250 SF	Tool Storage	225 SF	General Storage	225 SF	Conference	<u>150 SF</u>	Total	5,850 NASF
Shop	5,250 SF										
Tool Storage	225 SF										
General Storage	225 SF										
Conference	<u>150 SF</u>										
Total	5,850 NASF										
Adjacency relationships	Locate near Diesel Mechanics, Welding, and Plumbing Shops with personnel and multi-service accesses to outside service area and auto storage. Locate storage rooms and conference room near entrance and open directly into shop.										
Layout	See Figure 4-21										

INDIVIDUAL SPACE CRITERIA

DG 1110-3-112 May 1979

4-4 VOCATIONAL TRAINING SPACES (cont'd)

- | | |
|-------------------------------|---|
| 1. Wheel Visual Balancer | 20. Steam Cleaner |
| 2. Battery Charger | 21. Engine Stand |
| 3. Tire Changer | 22. 15" Drill Press with Motor |
| 4. Work Bench | 23. Parts Washer |
| 5. 2 Ton Ball Bearing Trolley | 24. Generator-Alternator-Regulator Test Bench |
| 6. Press — 40 ton | 25. Bolt-Amp Tester |
| 7. Work Bench | 26. Battery-Starter Testers |
| 8. Mechanical Service Bay | 27. Ignition Simulator |
| 9. Spark Plug Cleaner | 28. Goggle Cabinet |
| 10. Air Conditioner Tester | 29. Tool Cabinet |
| 11. Armature Tester | 30. Tool Storage Cabinet |
| 12. Engine Analyzer | 31. Industrial Shelving |
| 13. Infra-Red Co/HC Analyzer | 32. Storage Cabinets |
| 14. Distributor Tester | 33. Cabinet w/sink |
| 15. Shop Desk | 34. Overhead Door |
| 16. Auto Lift | 35. Conference Table and Chairs |
| 17. Valve Grinding Shop | 36. Chalkboard |
| 18. Brake Shop | 37. Tack Board |
| 19. 12" Grinder | |

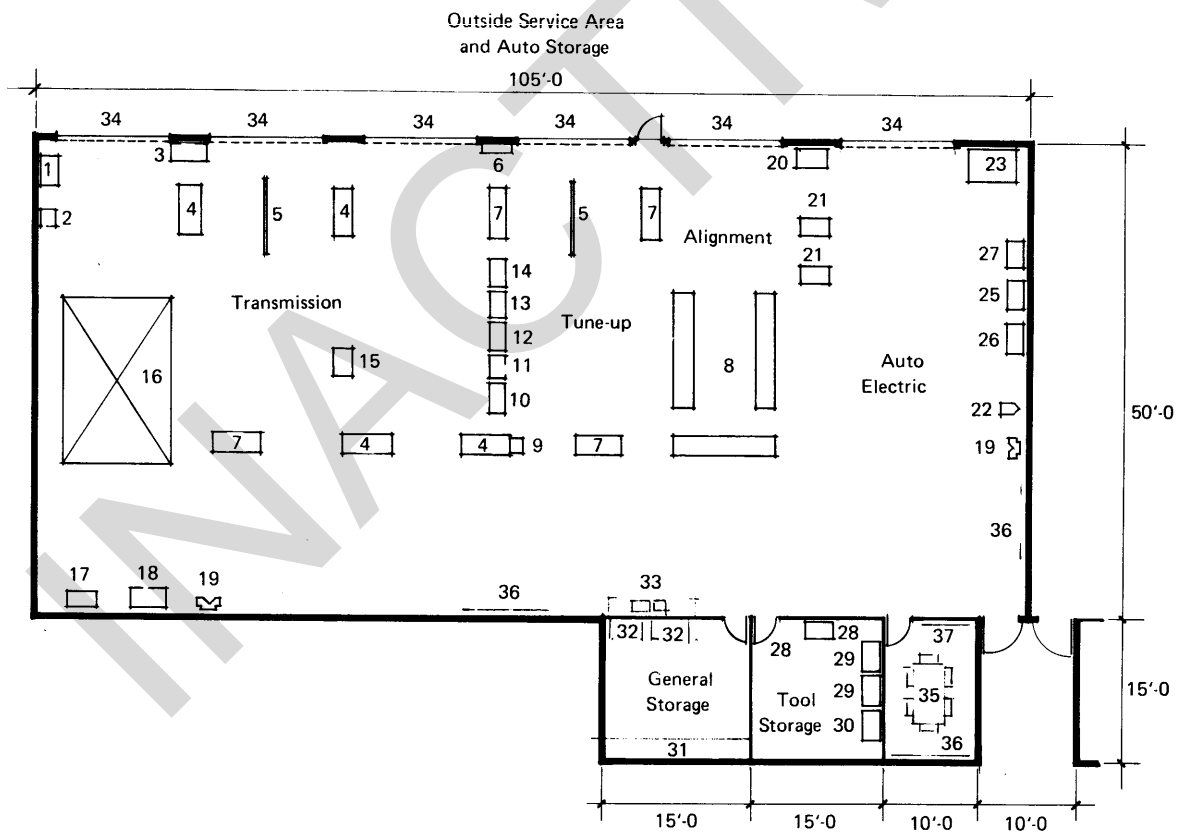

Figure 4-21 Auto Mechanics Shop

4-4 VOCATIONAL TRAINING SPACES (cont'd)

i. WELDING SHOP

Use	For lectures, demonstrations and laboratory experience with gas and arc welding equipment. Separate spaces are required for tool and general storage, for storing gas and oxygen safely, and for conferences. A small facility for outside scrap storage is also required.												
Occupant load	20 persons												
Space allocation	<table border="0" style="width: 100%;"> <tr> <td style="width: 80%;">Shop</td> <td style="text-align: right;">3,875 SF</td> </tr> <tr> <td>Tool Storage</td> <td style="text-align: right;">150 SF</td> </tr> <tr> <td>General Storage</td> <td style="text-align: right;">150 SF</td> </tr> <tr> <td>Conference</td> <td style="text-align: right;">150 SF</td> </tr> <tr> <td>Gas and Oxygen Storage (2@ 75)</td> <td style="text-align: right;">150 SF</td> </tr> <tr> <td style="border-top: 1px solid black;">Total</td> <td style="text-align: right; border-top: 1px solid black;">4,475 NASF</td> </tr> </table>	Shop	3,875 SF	Tool Storage	150 SF	General Storage	150 SF	Conference	150 SF	Gas and Oxygen Storage (2@ 75)	150 SF	Total	4,475 NASF
Shop	3,875 SF												
Tool Storage	150 SF												
General Storage	150 SF												
Conference	150 SF												
Gas and Oxygen Storage (2@ 75)	150 SF												
Total	4,475 NASF												
Adjacency relationships	Locate near Auto Mechanics and Auto Body Repair Shops with personnel and service access to outside service area. Locate scrap storage adjacent within service area. Locate gas and oxygen storage in explosion-proof rooms having direct access to outside service area as well as to shop. Locate other rooms for storage and conference near main entrance and open directly into shop.												
Layout	See Figure 4-22												

INDIVIDUAL SPACE CRITERIA

DG 1110-3-112 May 1979

4-4 VOCATIONAL TRAINING SPACES (cont'd)

- | | |
|----------------------------------|--------------------------------------|
| 1. Arc Welder | 14. Four Station Metal Working Bench |
| 2. Arc Welding Bench | 15. Machinists' Vise |
| 3. Two-station Gas Welding Bench | 16. Work Bench |
| 4. Pedestal Grinder | 17. Welding Testing Center |
| 5. Steel Top Layout Table | 18. Heat Treating Furnace |
| 6. TIG Welding Unit on Wheels | 19. Drill Press |
| 7. MIG-RID 3 Welding Unit | 20. Overhead Door |
| 8. Arc Welder with Wheels | 21. Cabinet with sink |
| 9. Anvil with Stand | 22. Tool Storage Cabinet |
| 10. Welding and Cutting Outfit | 23. Industrial Shelving |
| 11. Bar Storage Racks | 24. Conference Table and Chairs |
| 12. Spot Welder | 25. Chalkboard |
| 13. Power Hacksaw | 26. Tack Board |

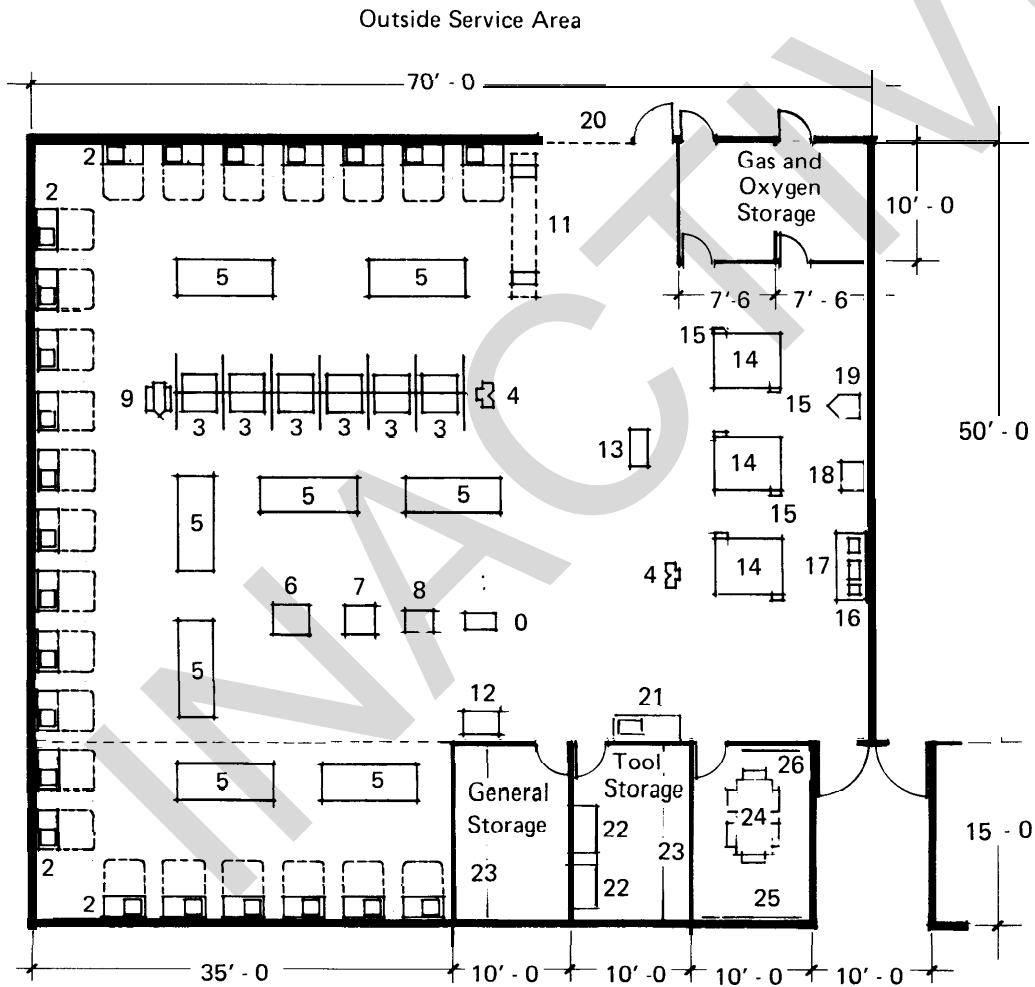

Figure 4-22 Welding Shop

4-4 VOCATIONAL TRAINING SPACES (cont'd)

j. AUTO BODY REPAIR SHOP

Use	For lectures, demonstrations and laboratory experience in auto body repair. Separate spaces are required for spray painting, for paint, tool and general storage, and for conferences. Outside storage for approximately ten cars and space for scrap storage is also required.														
Occupant load	20 persons														
Space allocation	<table border="0" style="width: 100%;"> <tr> <td style="width: 80%;">Shop</td> <td style="text-align: right;">3,650 SF</td> </tr> <tr> <td>Spray Painting Room</td> <td style="text-align: right;">600 SF</td> </tr> <tr> <td>Paint Storage</td> <td style="text-align: right;">75 SF</td> </tr> <tr> <td>General Storage</td> <td style="text-align: right;">450 SF</td> </tr> <tr> <td>Tool Storage</td> <td style="text-align: right;">150 SF</td> </tr> <tr> <td>Conference</td> <td style="text-align: right;">150 SF</td> </tr> <tr> <td style="border-top: 1px solid black;">Total</td> <td style="text-align: right; border-top: 1px solid black;">5,075 NASF</td> </tr> </table> <p>Outside Auto Storage 2000 SF (approximately)</p>	Shop	3,650 SF	Spray Painting Room	600 SF	Paint Storage	75 SF	General Storage	450 SF	Tool Storage	150 SF	Conference	150 SF	Total	5,075 NASF
Shop	3,650 SF														
Spray Painting Room	600 SF														
Paint Storage	75 SF														
General Storage	450 SF														
Tool Storage	150 SF														
Conference	150 SF														
Total	5,075 NASF														
Adjacency relationships	Locate near Welding Shop and Auto Mechanics Shop with personnel and multi-service accesses to outside service area. Outside auto and scrap storage areas should be adjacent. When provided with the Auto Mechanics Shop and/or Welding Shops, such areas should be centralized for combined use. Spray painting and paint storage should be located in separate, fire-proof rooms. The spray painting room should have direct service access to the outside service area. Locate rooms for general storage, tool storage and conference near entrance and open directly into shop.														
Layout	See Figure 4-23														

INDIVIDUAL SPACE CRITERIA

DG 1110-3-112 May 1979

4-4 VOCATIONAL TRAINING SPACES (cont'd)

- | | |
|---|--|
| 1. 15" Drill Press with Motor | 11. Infra-red Heater |
| 2. Combination Buffer/Grinder | 12. Complete Professional Spray Outfit |
| 3. Hardware Cabinet | 13. Overhead Door |
| 4. Work Bench | 14. Cabinet with Sink |
| 5. Spot Welder | 15. Tool Storage Cabinet |
| 6. Welding Package | 16. Industrial Shelving |
| 7. Steam Cleaner/Washer | 17. Conference Table and Chairs |
| 8. Auto Body and Frame Alignment System | 18. Chalkboard |
| 9. Work Bench | 19. Tack Board. |
| 10. Paint Cabinet | |

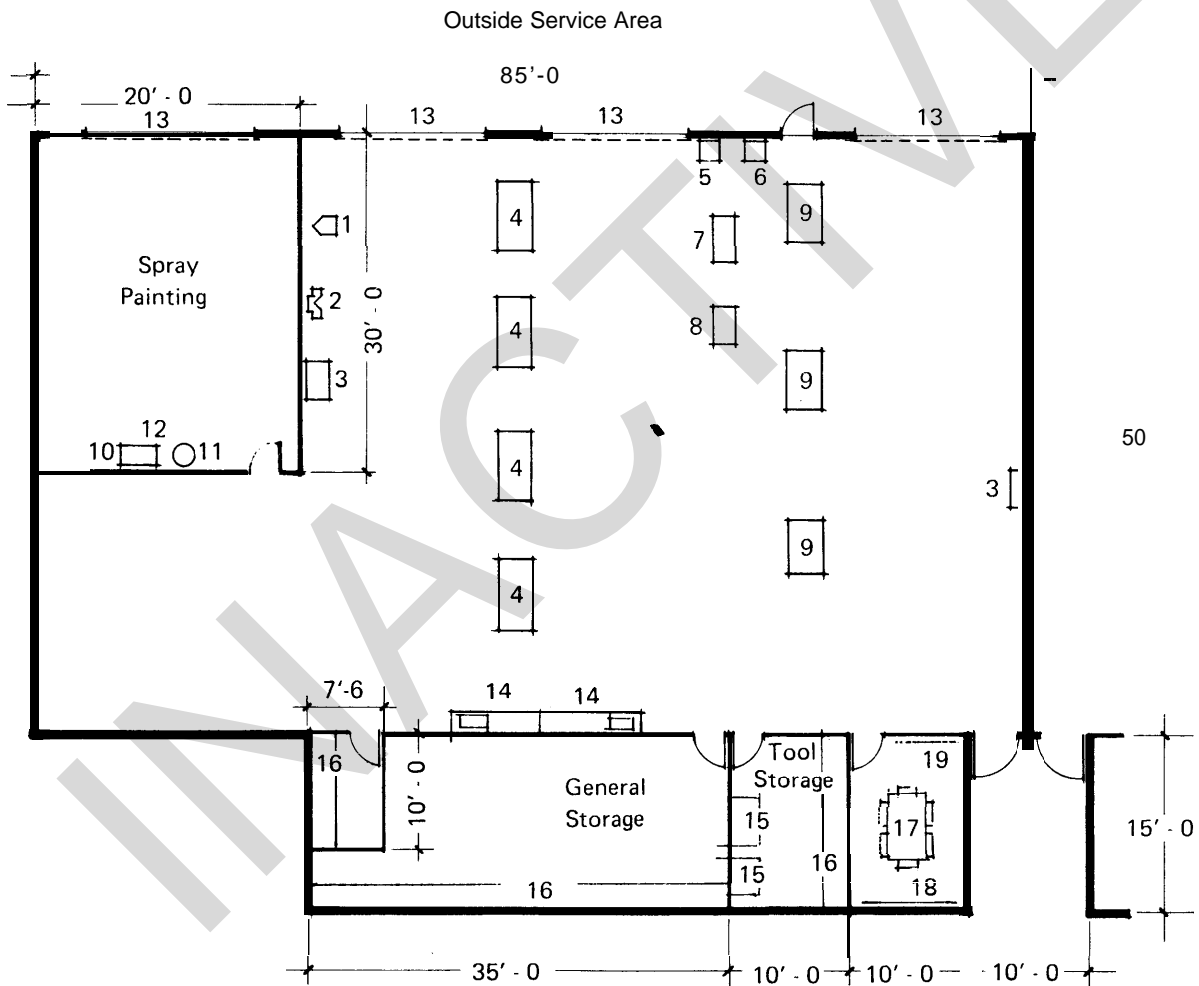

Figure 4-23 Auto Body Repair Shop

4-4 VOCATIONAL TRAINING SPACES (cont'd)

k. SMALL ENGINE REPAIR SHOP

Use	For lectures, demonstrations and laboratory experience in small engine repair. Separate spaces are required for tool and general storage, and for conferences.										
Occupant load	20 persons										
Space allocation	<table border="0" style="margin-left: 20px;"> <tr> <td>Shop</td> <td style="text-align: right;">3,000 SF</td> </tr> <tr> <td>General Storage</td> <td style="text-align: right;">375 SF</td> </tr> <tr> <td>Tool Storage</td> <td style="text-align: right;">150 SF</td> </tr> <tr> <td>Conference</td> <td style="text-align: right;">150 SF</td> </tr> <tr> <td style="border-top: 1px solid black;">Total</td> <td style="text-align: right; border-top: 1px solid black;">3,675 NASF</td> </tr> </table>	Shop	3,000 SF	General Storage	375 SF	Tool Storage	150 SF	Conference	150 SF	Total	3,675 NASF
Shop	3,000 SF										
General Storage	375 SF										
Tool Storage	150 SF										
Conference	150 SF										
Total	3,675 NASF										
Adjacency relationships	Locate near Heating/Refrigeration/Air-conditioning Shop and Communications/Industrial Electronics Shop with personnel and service access to outside service area. Locate rooms for general storage, tool storage and conference near entrance and open directly into shop.										
Layout	See Figure 4-24										

INDIVIDUAL SPACE CRITERIA

DG 1110-3-112 May 1979

4-4 VOCATIONAL TRAINING SPACES (cont'd)

- | | |
|---|-------------------------------------|
| 1. Portable Work Bench | 16. Parts Washer |
| 2. Work Bench w/2 Mechanic's Vises | 17. Utility 15" Drill Press |
| 3. Swivel Engine Stand | 18. Long Shaft Buffer-wire Wheel |
| 4. Bench Mounted Holding Fixture | 19. Grinder with Stand |
| 5. Bench Powerlab with tools (exhaust gas collection vent needed) | 20. Outboard Motor Stand – Portable |
| 6. Portable Engine Hoist | 21. Outboard Motor Stand |
| 7. Small Engine Technology Center | 22. Outboard Motor Test Tank |
| 8. Power Mechanic Teaching System | 23. Cart |
| 9. Projection Screen | 24. Storage Cabinet |
| 10. Chalk/tack Surface | 25. Tool Storage Cabinet |
| 11. Instructor Desk and Chair | 26. Industrial Shelving |
| 12. File Cabinet | 27. Cabinet with Sink |
| 13. Student Chairs | 28. Overhead Door |
| 14. Wall Bench Unit | 29. Conference Table and Chairs |
| 15. Fuel and Refueling System | |

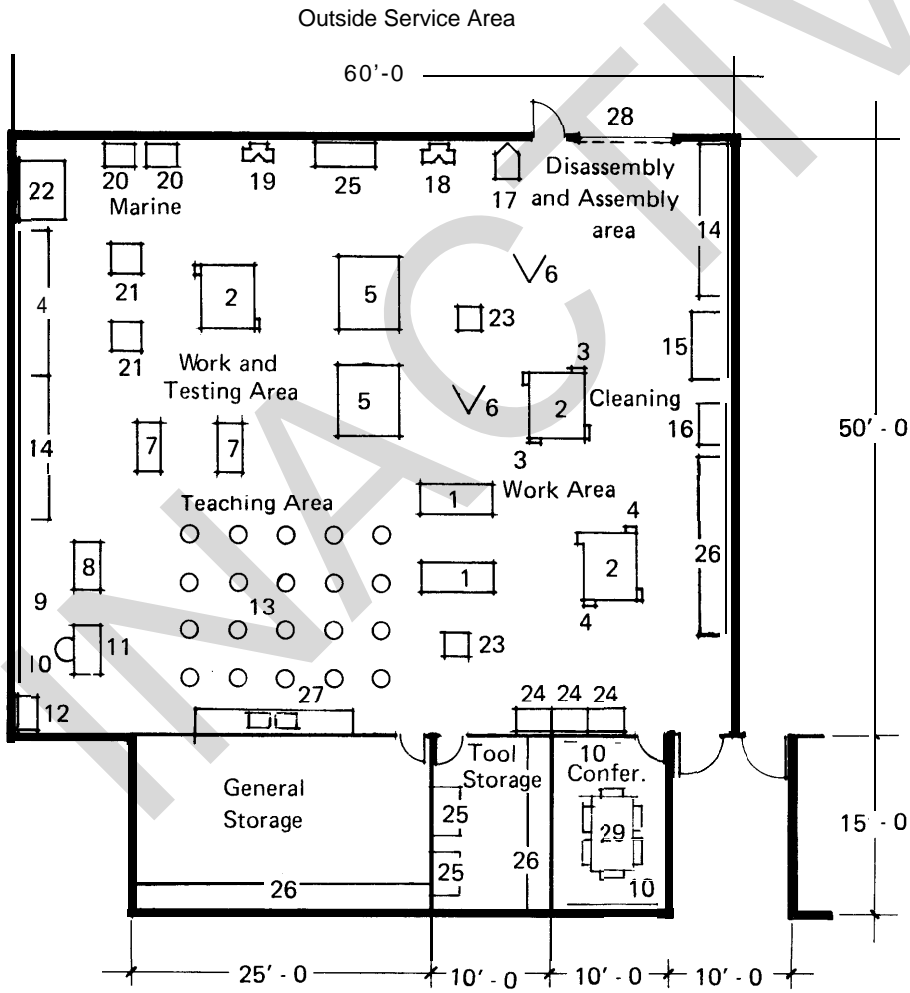

Figure 4-24 Small Engine Repair Shop

4-5 SUPPORT SPACES

Support spaces include staff and student lounges, vending area, training aids preparation, receiving and storage, toilets and janitor closet.

a. STAFF LOUNGE

Use	For informal meetings, coffee breaks, lunch and general relaxation.
Occupant load	6 persons (min)
Space allocation	1.5% of the combined NASF for academic and staff spaces; or 150 NASF (min)
Adjacency relationships	Locate near staff offices and adjacent to vending area.
Layout	See Figure 4-25

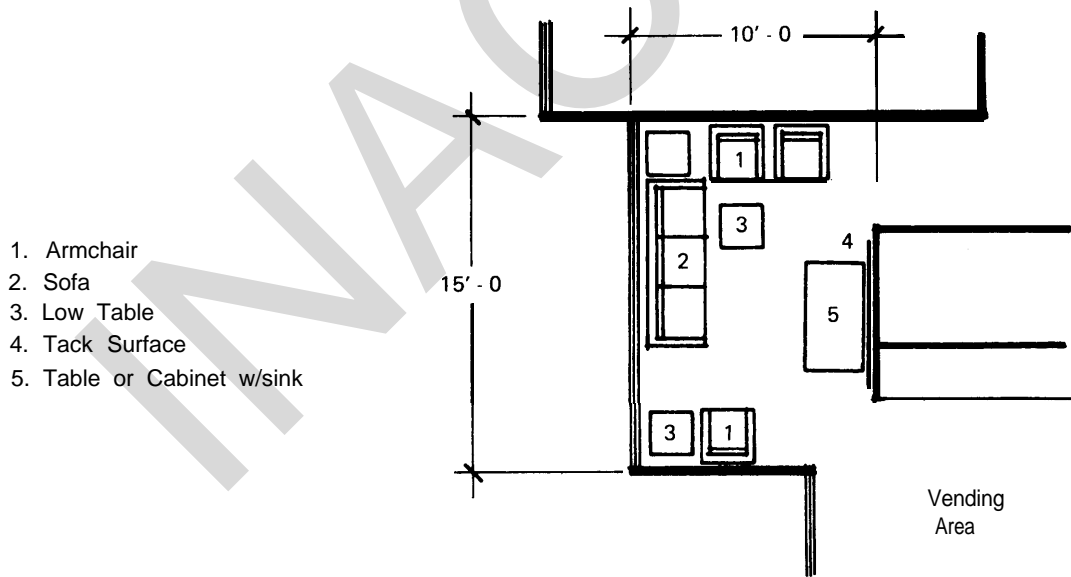

Figure 4-25 Staff Lounge

INDIVIDUAL SPACE CRITERIA

DG 1110-3-112 May 1979

4-5 SUPPORT SPACES (cont'd)

b. STUDENT LOUNGE

Use	For relaxation during class breaks, lunch hour and unscheduled class time.
Occupant load	18 persons (min)
Space allocation	5.5% of the combined NASF for academic and staff spaces; or 400 NASF (min)
Adjacency relationships	Locate adjacent to the vending area to permit food consumption and alleviate crowding of the vending area during periods of heavy usage. Also locate near the main entrance for convenience of visitors and for visibility. Lounge space may also be dispersed throughout the building. This may be more convenient than a centrally located lounge, and could provide visual interest to the circulation area.
Layout	See Figure 4-26

1. Arm Chair
2. Low Table
3. Table and Chairs
4. Tack Surface

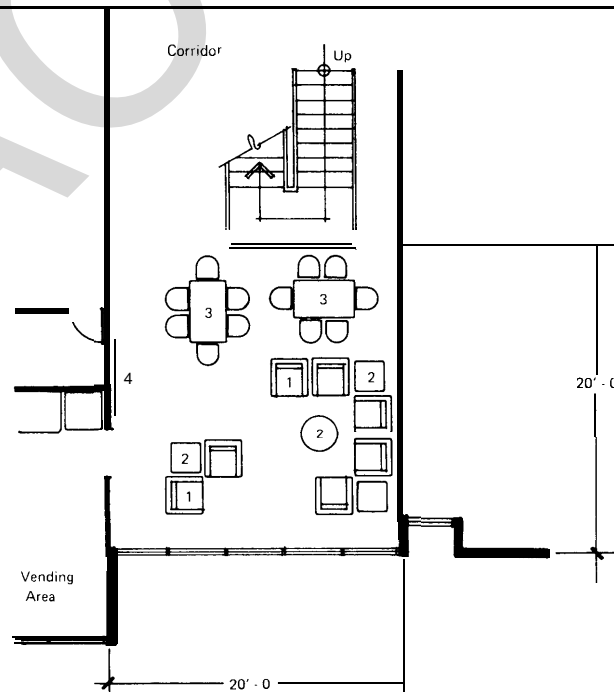

Figure 4-26 Student Lounge

INDIVIDUAL SPACE CRITERIA

DG 1110-3-112 May 1979

4-5 SUPPORT SPACES (cont'd)

c. VENDING AREA

Use	For vending and consumption of snacks, beverages, cigarettes, candy, etc. A separate space is also needed for storage.
Occupant load	12 persons (min)
Space allocation	3% of the combined NASF for academic and staff spaces; or 300 NASF (min)
Adjacency relationships	Locate adjacent to the student lounge and staff lounge.
Layout	See Figure 4-27

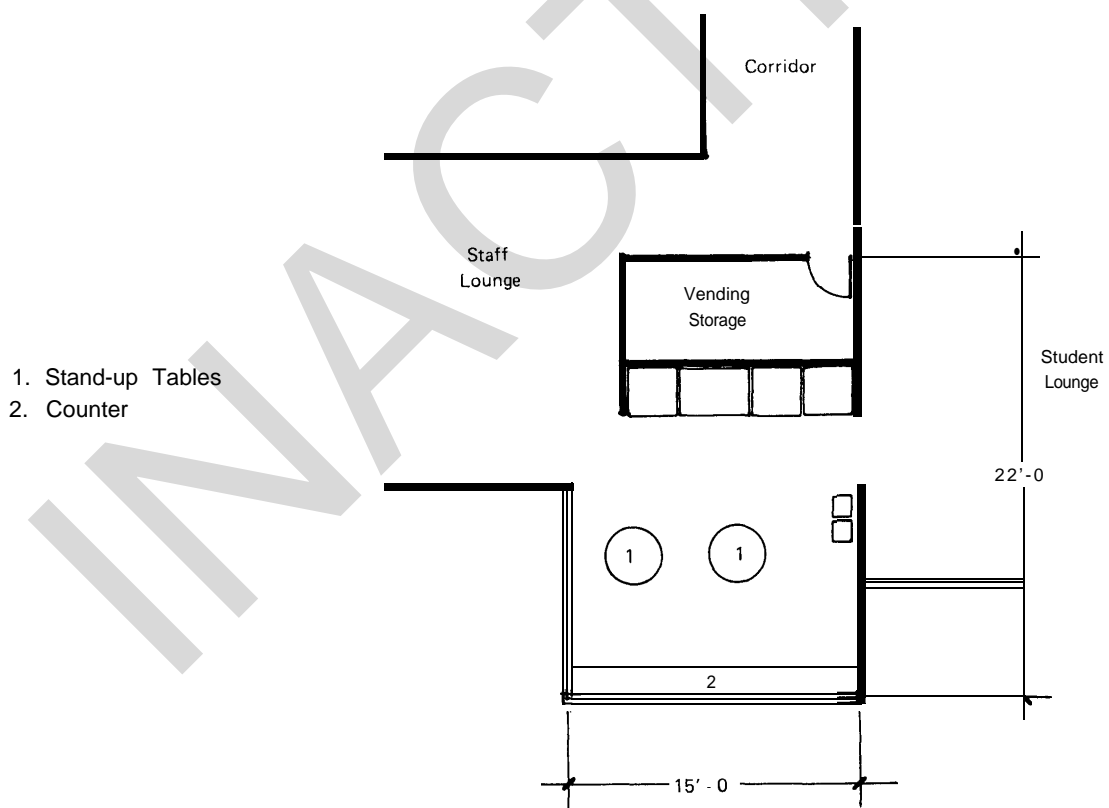

Figure 4-27 Vending Area

INDIVIDUAL SPACE CRITERIA

DG 1110-3-112 May 1979

4-5 SUPPORT SPACES (cont'd)

d. TRAINING AIDS PREPARATION

Use	For preparation of graphic aids and other material, and for duplication.
Occupant load	4 persons (min)
Space allocation	4% of the combined NASF for academic and staff spaces; or 300 NASF (min)
Adjacency relationships	Locate near staff offices and the receiving room.
Layout	See Figure 4-28

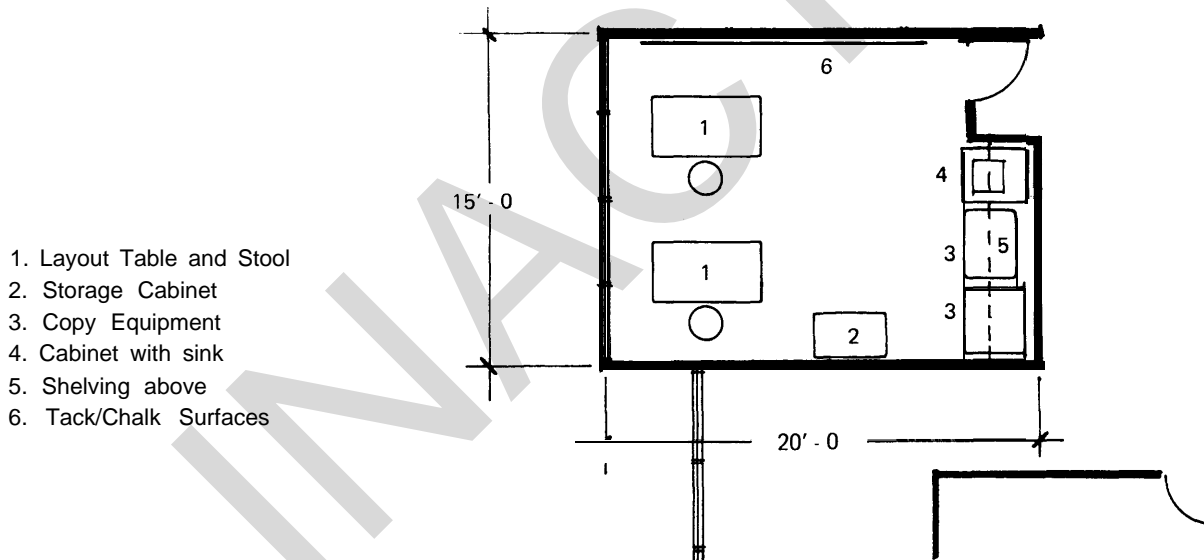

Figure 4-28 Training Aids Preparation

4-5 SUPPORT SPACES (cont'd)

e. TOILETS

Use	For sanitary purposes, shared between students and staff, with separate facilities for men and women. Separate space is required for lockers and showers in toilets serving vocational training space.	
Occupant load	Varies	
Male/Female Ratio	For toilets serving academic spaces, assume 25% utilization by women and 75% utilization by men unless local circumstances indicate otherwise. For toilets, showers and lockers serving vocational training spaces, assume 10% utilization by women and 90% utilization by men unless local circumstances indicate otherwise. Base assumptions on peak occupant loads in the respective areas that the facilities will support.	
Fixture allocation	Water closets	1/40 men 1/25 women
	Urinals	1/40 men
	Lavatories	1/25 men 1/25 women
	Showers	1/15 men 1/15 women
	Lockers	1/man 1/woman
Space Allocation (unit estimates)	Water closet compartment	30 SF
	WC compartment for handicapped	50 SF
	Lavatory	15 SF
	Urinal	15 SF
	Shower compartment	35 SF
	Locker tier (2 lockers/tier)	5 SF
	Detailed provisions for handicapped persons shall conform to current criteria (EM 1110-1-103).	

INDIVIDUAL SPACE CRITERIA

DG 1110-3-112 May 1979

4-5 SUPPORT SPACES (cont'd)

Adjacency relationships

Locate toilets central to academic spaces and near to the main entrance and lounges. No occupant should have to travel more than 150 feet to reach a toilet facility. Toilets, including lockers and showers, serving vocational training spaces should be convenient to users, both inside and outside the building.

Layout

See Figure 4-29

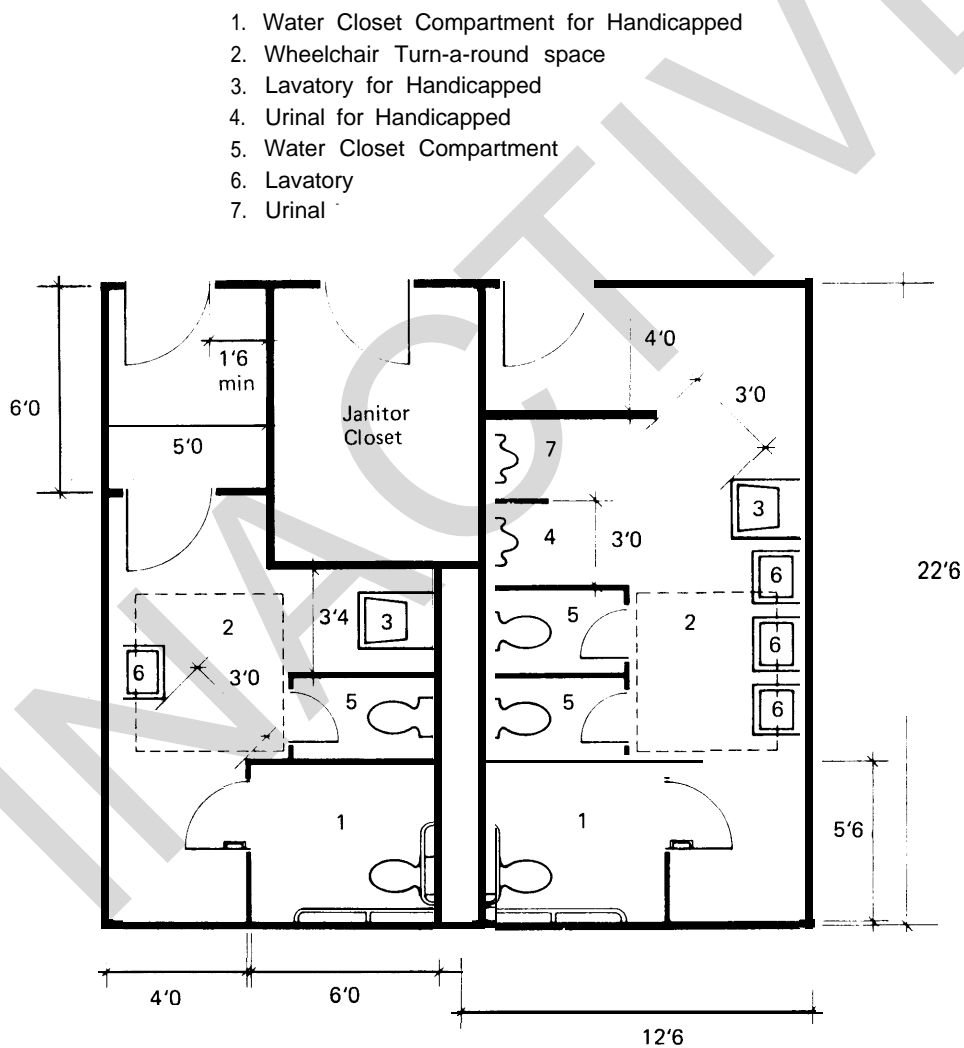

Figure 4-29 Toilets

4-3 SUPPORT SPACES (cont'd)

f. RECEIVING AND GENERAL STORAGE	
Use	For receiving, unpacking and temporary storage of educational materials and equipment.
Occupant load	5% of the combined NASF for academic and staff spaces; or 300 NASF (min).
Adjacency relationships	Locate close to an outside service entrance and staff spaces. General storage may be in a separate room but should be adjacent.
Layout	See Figure 4-30

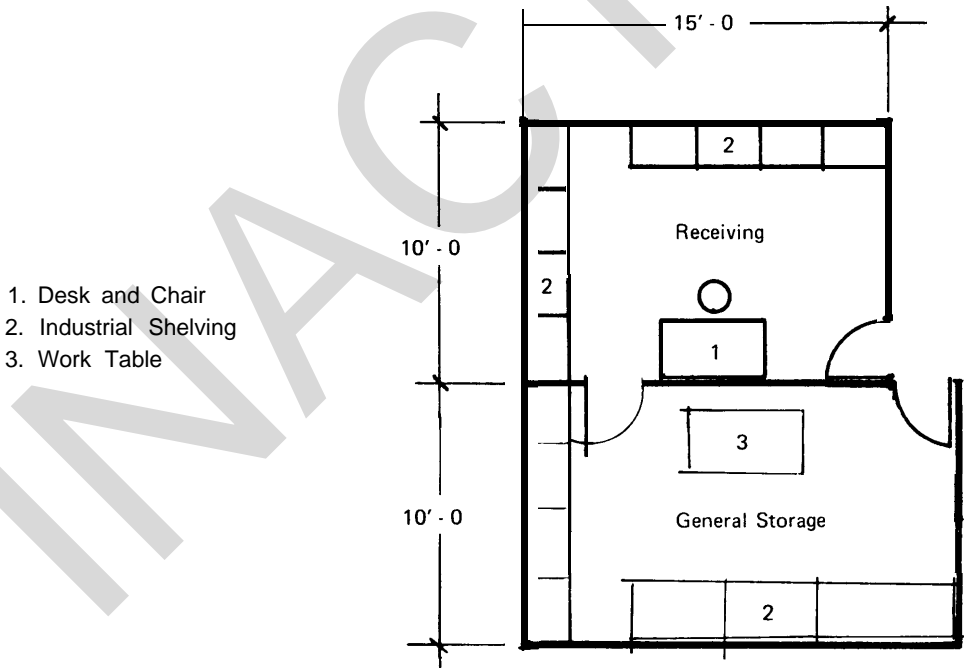

Figure 4-30 Receiving and General Storage

INDIVIDUAL SPACE CRITERIA

DG 1110-3-112 May 1979

4-5 SUPPORT SPACES (cont'd)

g. JANITOR CLOSET

Use	For housekeeping, preparations and storage of cleaning gear and supplies.
Occupant load	N/A
Space allocation	1% of the combined NASF for academic and staff spaces; or 90 NASF (min).
Adjacency relationships	Locate centrally to minimize walking distances and near toilets. Space may be segmented to other parts of the facility where need exists.
Layout	See Figure 4-31

1. Service Sink
2. Cabinet
3. Shelving
4. Mop Holder
5. Broom Holder
6. Brush Holder
7. Pail Hooks
8. Towel Bars
9. Tack Board

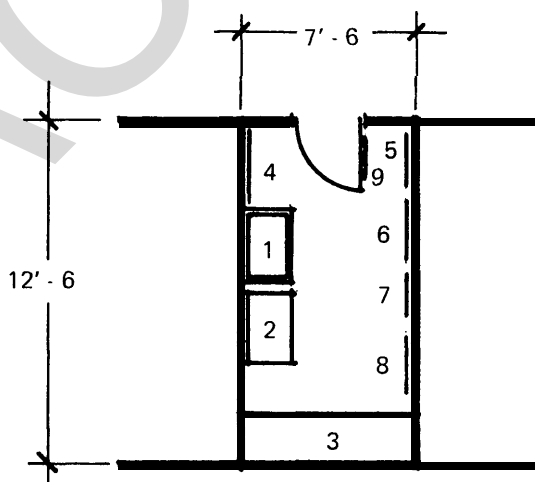

Figure 4-31 Janitor Closet

4-6 SUMMARY OF ENVIRONMENTAL CRITERIA

Table 4-1 covers environmental criteria for each individual space discussed in this chapter.

Table 4-1 Summary of Environmental Criteria for Individual Spaces

SPACE	Max Occupant Load	Mechanical/Plumbing					Electrical					Lighting			Acoustical					
		Thermostat	Air Changes /Hr	CW/HW	Floor Drain	Compress'd Air Exhaust	Intercom	Elec Outlets	PA Speaker	Telephone	Clock	TV/Elec Outlet	Daylight	Blackout Capability	Light intensity FC	Dimming capability Task Light Supplement	Ambient dB	Estimated Peak dB	Sound Quality	
Director's Office	1	X	6-8				X	X	(6)	X	X	X	X	X	70	0	0	40	75	AVE
Administrator	1	X	6-8				X	X	(6)	X	0	0	0	0	70	0	0	40	75	AVE
Clerk		X	6-8				X	X	(6)	X	0	0	0	0	70	0	0	40	75	AVE
Typist		X	6-8				X	X		X	0	0	0	0	70	0	0	45	75	AVE
Registrar	1	X	6-8				X	(9)	(6)	(9)	X	X	0	0	70	0	0	45	75	AVE
Information/Registration		0	6-8	(3)			X	X	(8)	0	X				60	X		50	80	ML
Counselor	1	X	6-8				X	X	(6)	X	0	0	0	0	70	0	0	40	75	AVE
Classroom	25	X	6-8				X	X	0	X	X	X	X	X	70	X	0	35	80	ML
Lecture Room	53	X	6-8				X	X	0	X	X	X	0	X	70	X	0	40	85	ML
Seminar Room	13	X	6-8				X	X	0	X	X	X	0	X	70	X		40	70	AVE
MOS Library	9	X	6-8				0	(7)	X	X	X	X	X	X	70	0	0	40	70	MD
Self-Paced Instr.	20	X	6-8				(7)	X	X	X	X	X	0	X	70	X	X	35	70	MD
Language Lab	22	X	6-8				(7)	X	0	X	X	X	X	X	70	X		35	80	MD
Science Lab	25	X	(1)	X	(2)	0	X	X	0	X	X	X	X	X	70	X	X	45	85	ML
Testing Room	50	X	6-8				X	X	X	X	X	X	0	X	70	X		35	75	AVE
Reh/Rec Studio	6	X	6-8				(5)	(6)		X	X		X	X	70	X	X	30	75	D
Htg/Refrig/AC Shop	20	X	(1)	X	X	X	(5)	X	0	X	X	0	0	70	X			45	90	AVE
Constr. Electrician	20	X	(1)		X	X	(5)	X		X	X	0	0	70	X			50	90	ML
Comm/Indus. Electrician	20	X	(1)		X	X	(5)	X		X	X	0	0	70	X			50	90	AVE
Masonry	20	X	(1)	X	X	X	(5)	X		X	X	0	0	70	X			50	100	AVE
Carpentry	20	X	(1)	X	X	X	(5)	X		X	X	0	0	70	X			50	100	AVE
Plumbing	20	X	(1)	X	X	X	(5)	X		X	X	0	0	70	X			50	100	AVE
Diesel Mechanics	20	X	(1)	X	X	X	(5)	X		X	X	0	0	70	X			50	95	AVE
Auto Mechanics	20	X	(1)	X	X	X	(5)	X		X	X	0	0	70	X			55	95	AVE
Welding	20	X	(1)	X	X	X	(5)	X		X	X	0	0	70	X			50	85	AVE
Auto Body Repair	20	X	(1)	X	X	X	(5)	X		X	X	0	0	70	X			55	90	AVE
Small Eng. Repair	20	X	(1)	X	X	X	(5)	X		X	X	0	0	70	X	X		45	95	AVE
Shop Conference Rms	—	X	6-8				X	X	X	0	0	0	X	70	X			40	70	ML
Staff Lounge		0	8-10				X	X	X	X	X	X	X	60	0	0	0	40	75	MD
Student Lounge		0	8-10	(3)			X	X	(8)	X	X	X	X	60	0	0	0	40	80	MD
Vending Area		0	(1)	(4)	X	X	(5)	0				0	0	70				45	80	ML
Training Aids Prep.		X	(1)	X		X	X	(5)	X	0	X	X	0	X	70	X	X	40	80	AVE
Toilets			(1)	X	X	X	X	0				0	0	50	X			50	80	ML
Receiving/Gen. Stor.		0	6-8				X	X	X	X				50	X			55	70	ML
Janitor Closet			6-8	X	X		X							50				55	70	L

(1) 8-10 Air Changes/Hour minimum; exhaust requirements govern
 (2) For emergency shower
 (3) Drinking fountain desirable
 (4) Some vending machines require cold water
 (5) Also as required by equipment
 (6) On/Off, volume control

(7) Also as required for AV carrels
 (8) Pay telephone
 (9) Also for computer terminal

X — Required
 O — Optional

5-1 GENERAL.

This chapter describes space organization principles that may be employed in the development and review of designs. A principle is defined here as a rule exemplified in the organization and layout of a building design, after the space requirements have been established as discussed in Chapter 2, paragraph 2-5. Principles are described in this chapter in relation to the following, general design sequence.

a. ESTABLISH AFFECTS OF THE SITE. Principles concerning site topography, climate, size and shape, orientation, etc., will determine the general configuration and location of the building on the site.

b. ESTABLISH BASIC SPATIAL ORGANIZATION. The site constraints together with the overall mission and desired image of the ACES Center will help establish the scheme of spatial organization best suited to an individual project.

c. DEVELOP FUNCTIONAL LAYOUT. Principles concerning functional adjacency, circulation, control, acoustics, etc., will determine the location of spaces within the basic configuration.

d. DEVELOP STRUCTURAL AND ENVIRONMENTAL SUPPORT MODULES. Principles concerning mechanical zoning, ceiling height, structural loading, modularity, and maintenance will determine adjustments to the building layout needed to make the facility habitable and constructible.

e. DEVELOP CONCEPT FLOOR PLAN.

5-2 PRINCIPLES RELATED TO SITE CONSTRAINTS AND OPPORTUNITIES

a. ORGANIZE SPACES IN RELATION TO THE SIZE, SHAPE AND ORIENTATION OF THE SITE. Based on the maximum coverage of the site desired, the building may be single-story or multi-story. Space organization must also consider the orientation of the site which will tend to determine the locations that will provide views and natural lighting or that will require protection against sun and glare.

b. ORGANIZE SPACES TO FIT INTO THE NATURAL TOPOGRAPHY. Existing ground forms, trees and other site features should be preserved insofar as is reasonably possible. At the same time the space organization must function efficiently both indoor and outdoor. For example, a sloping site may suggest a split-level facility to preserve natural features, while access for the physically handicapped from parking areas into the building may require grading to reduce slopes in certain areas. Spaces should be organized to take advantage of existing views.

c. ORGANIZE SPACES SO THAT THEY MAY BENEFIT FROM NATURAL WARMING AND COOLING EFFECTS. Where possible, building forms, courtyards, earth mounds, vegetation and trees should be provided to capture or direct air movement as well as to control the effects of the sun.

SPACE ORGANIZATION

DG 1110-3-112 May 1979

5-2 PRINCIPLES RELATED TO SITE CONSTRAINTS AND OPPORTUNITIES (cont'd)

d. ORGANIZE SPACES IN RELATION TO VEHICULAR/PEDESTRIAN CIRCULATION. This must be accomplished with respect to access (to both site and building) by students, visitors and staff (including the handicapped), maintenance and service personnel.

- (1) The main entrance should be visible from both the parking lot and the street.
- (2) Service entrances should not be visible from the parking lot and the street, but should be identified with signs.

e. ORGANIZE SPACES TO ALLOW FUTURE EXPANSION OF FACILITIES. Existing or planned facilities which would limit orderly growth must be taken into consideration. If the building expands, site amenities such as parking will also require expansion.

5-3 PRINCIPLES RELATED TO BASIC SPATIAL ORGANIZATION

a. ORGANIZE SPACES INTO BASIC ORGANIZATIONAL SCHEMES. Spaces should be grouped to afford compatibility of activities, circulation and service requirements. The following three schemes are most applicable to ACES facilities:

(1) Parallel Organization. This scheme is characterized by parallel circulation spines along which groups of spaces with similar functions are arranged. The academic and staff spaces are arranged along one spine, and the vocational-training spaces are grouped separately along another spine, as shown in Figure 5-1. The parallel scheme gives distance between academic and vocational-training activities which facilitates noise control, but may inhibit visual control. This type of scheme provides excellent opportunities for expansion, but may be difficult to adapt to unusual site conditions.

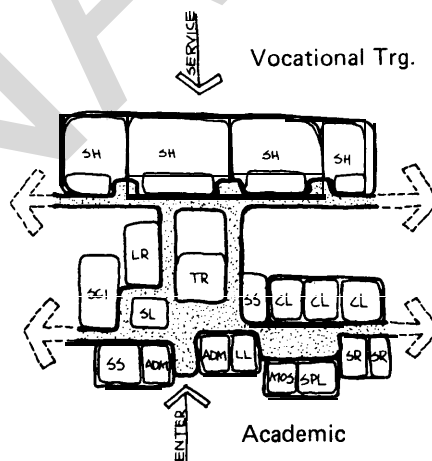

Figure 5-1 Parallel Organization Scheme

5-3 PRINCIPLES RELATED TO BASIC SPATIAL ORGANIZATION (cont'd)

(2) Axial Organization. This scheme is developed by dividing the circulation into two axial paths separating the academic and vocational-training spaces along two different axes as shown in Figure 5-2. Spaces can be arranged along the axis on one or both sides. The axial scheme facilitates both noise and visual control. It also provides excellent opportunity for expansion of facilities and adapts well to varying site conditions.

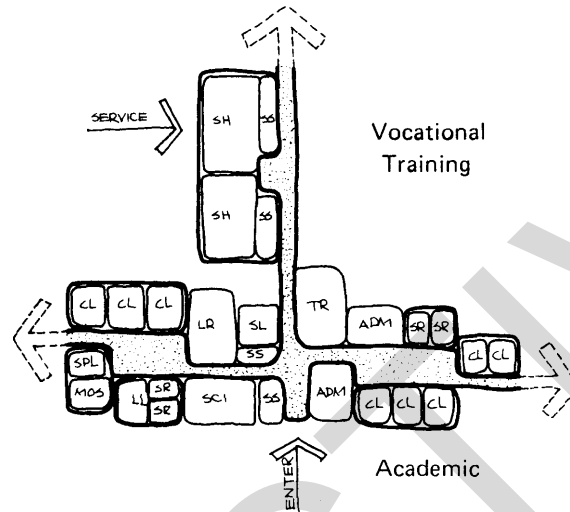

Figure 5-2 Axial Organization Scheme

(3) Dispersed Organization. This scheme is characterized by circulation linkages that both connect and separate activities. Academic and vocational-training spaces are arranged along individual spines, separated by a connector spine along which staff and support spaces are arranged as shown in Figure 5-3. The dispersed scheme also facilitates good noise control but may inhibit visual control. This scheme is more suitable for severe climate conditions but may have limited adaptability to difficult site conditions.

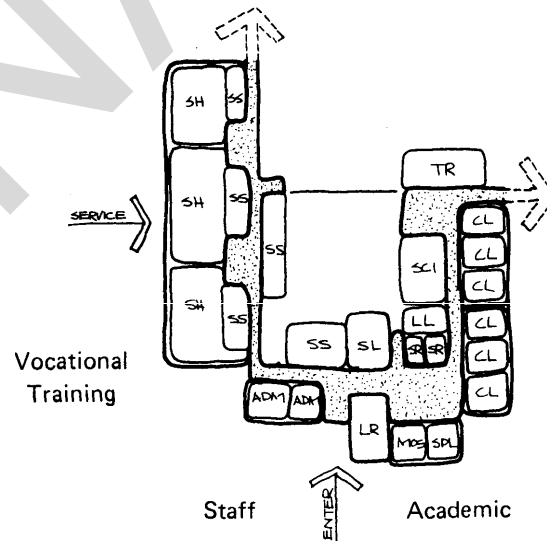

Figure 5-3 Dispersed Organization Scheme

SPACE ORGANIZATION

DG 1110-3-112 May 1979

5-3 PRINCIPLES RELATED TO BASIC SPATIAL ORGANIZATION (cont'd)

b. ORGANIZE SPACES IN CONJUNCTION WITH PLANNED SEQUENCES OF VIEWING POSITIONS. Each viewing position should be used to create a perceptual experience for participants as they move through the spatial organization scheme. Such experiences can be created by: arranging spaces to emphasize volumetric differences in heights, widths and lengths; through the use of focal points established by light, form and color (including natural elements inside and out); and through the use of decorative elements (color, texture, light and form) to establish visual rhythm and movement. Sequences of viewing positions should always be coordinated with circulation flows even though they may involve separate paths.

5-4 PRINCIPLES RELATED TO FUNCTIONAL LAYOUT.

a. ORGANIZE SPACES TO ESTABLISH WORKABLE ADJACENCY RELATIONSHIPS. Students, visitors and staff must interact with one another, and some activities must be closely associated. Generally, the greater the interaction of persons and activities, or flow of materials between one space and another, the closer the spaces should be to each other.

b. ORGANIZE SPACES TO ESTABLISH A CONVENIENT CIRCULATION FLOW. Visitors and students must be able to easily enter and exit the building and find the activities and staff provided. Staff must also be able to readily perform the tasks required, moving the material and equipment necessary to conduct instructional and other functions. Usually, spaces which generate heavy traffic should be located near to entrances, and those frequented by persons unfamiliar with the ACES Center should be near the main entrance.

c. ORGANIZE SPACES SO THAT ALL PERSONS CAN BE EFFECTIVELY EVACUATED DURING AN EMERGENCY. Space should be located, with respect to type and load of occupancy, to minimize distance of travel to safe outside exits, or to protective construction zones.

d. ORGANIZE SPACES FOR FLEXIBILITY OF SPACE USE. Spaces should be organized so that they may be combined, separated or slightly modified to enhance the versatility of the building and to accommodate possible changes in ACES program functions. Space organization should allow for changes in degree of privacy, from being open for visual control to being closed for privacy.

e. ORGANIZE SPACES TO SIMPLIFY VISUAL CONTROL. Spaces requiring surveillance and control should be organized so that there is capability to supervise from a central viewing position or positions. Capability to supervise entrance and exit traffic, use of toilets and equipment is an example.

f. ORGANIZE SPACES IN RELATION TO SOUND LEVEL COMPATIBILITY. Cluster spaces which produce high noise levels so they can be more economically isolated or located remote from quiet spaces. Separate noisy from quiet spaces with circulation, storage and toilet spaces where possible.

5-5 PRINCIPLES RELATED TO STRUCTURE AND ENVIRONMENTAL SUPPORT.

a. ORGANIZE SPACES TO MAXIMIZE ECONOMY OF STRUCTURE. Establish a standard module (where applicable) which is efficient and economical for both the layout of structure and the layout of ceiling and wall systems, lighting and air handling equipment. The structure must handle critical floor loads and allow for possible multi-use. Overall, the building should be made as compact as possible, to minimize both structure and HVAC support in terms of heat loss and/or gain.

b. ORGANIZE SPACE TO MINIMIZE REQUIREMENTS FOR RESISTIVE CONSTRUCTION AND/OR EXTINGUISHMENT SYSTEMS. Group spaces requiring this type of protection.

c. ORGANIZE SPACES TO PROVIDE PROTECTIVE CONSTRUCTION ZONES. Where fallout or storm protection is required, spaces which employ resistive construction for other purposes (e.g., fire protection) and those that may have built-in characteristics for providing such protections should be organized where possible into dual-use protective zones.

d. ORGANIZE SPACE TO MAXIMIZE ECONOMY OF ENVIRONMENTAL SUPPORT SYSTEMS. Spaces should be organized into comfort zones where different lighting and/or HVAC may be required to support the activity in the space or group of spaces. (See chapter 4, Table 4-1 for a summary of environmental criteria.) Spaces requiring plumbing services should be organized to minimize pipe runs, for both supply and waste. Space for mechanical/electrical equipment requiring the attention of facilities engineer personnel and communications officer such as for operation, maintenance and repair purposes, should be located to provide both efficient service to respective groups of spaces, and access from the outside.

6-1 GENERAL

This chapter demonstrates the application of criteria in developing concept alternatives for different ACES Center projects to serve the given military strength of 6,000, 10,500 and 21,000 persons. One example is given for each size military strength in Schemes A, B and C. Scheme A, discussed in para 6-2, most fully illustrates the planning and programming process. Schemes A-1, B-1 and C-1 follow as alternative designs to illustrate the affect of different site conditions on space organization. The procedure, as well as the information, is in abbreviated form to illustrate the most important considerations. An in-depth analysis with detailed information from each particular installation will be required in planning and designing an actual project.

6-2 EXAMPLE DESIGN-SCHEME A FOR 6,000 MILITARY STRENGTH

a. SITUATION. The project is located on an installation in the Midwestern United States. The existing ACES activity is housed in two separate structures which were converted from barracks and are both inefficient and unable to meet current needs. A relatively small rectangular site is identified on the master plan for a new ACES Center, and the installation commander has requested that a new facility be provided. The project site is within walking distance of the Exchange and main Library. It is gently sloping to the southwest and is defined by a secondary road on the south. The site has no significant features or views.

The existing program has a fairly constant semester enrollment of 700 people that utilize facilities at different times during the week. The activity operates five days per week from 7:30 a.m. to 4:00 p.m. with some classes occasionally meeting in the evening from 7:30 to 9:00 p.m. Although classes are not held on weekends, some space is used for recreational activities such as movies and lectures in order to supplement a relatively small and already over-burdened Recreation Center.

b. PLANNING DATA

(1) Authorized Space Allowance. A 6,000 person (military strength) installation is allowed (Table 2-1) up to 16,920 GSF, excluding mechanical space, for an ACES Center.

(2) Staffing. Authorized staffing is shown in Table 6-1.

EXAMPLE DESIGNS

DG 1110-3-112 May 1979

6-2 EXAMPLE DESIGN-SCHEME A FOR 6,000 MILITARY STRENGTH (cont'd)

Type	No. of Authorized Staff
Director	
Administrator	
Clerk	
Typist	2
Registrar	1
Counselors	5
Total	11

(3) Anticipated Courses and Enrollment. Based on a ten-year projection of student needs at the installation, a range of programs, courses and services is anticipated and include the following: Basic Skills Education Programs (BESEP), Skill Development, Counseling, ACES testing, MOS related instruction, foreign language instruction, group study classes, baccalaureate and advanced degree programs. The typical semester courses and enrollment anticipated are shown in Table 6-2.

(4) Assignment of courses to Instructional Space Types. Referring to the individual space types in Chapter 4 (Academic; para 4-3); each course anticipated to be taught at the ACES Center is assigned to a specific space type (Classroom, Lecture Room, Science Lab, etc.). The number of hours per week that the space type is required ("C" Value) is then determined by using the parameters set forth in Chapter 2 (Table 2-2). In this example, the courses assigned to a "Classroom" type space are shown in Table 6-3, along with the parameters set forth in Chapter 2 to determine the "C" Value. Detail assignments to other space types and "C" value determinations are not shown.

6-2 EXAMPLE DESIGN-SCHEME A FOR 6,000 MILITARY STRENGTH (cont'd)

**Table 6-2 Typical Semester Courses & Enrollment Based on 10-Year Projection
Example for Military Strength of 6,000**

Course Designation	Enrollment
<u>Academic</u>	
1. English 1	88
2. English 2	67
3. English Comp.	60
4. English Literature	12
5. World Literature	10
6. Arithmetic	38
7. Business Math	48
8. Principles of Accounting	48
9. Algebra 1	47
10. Geometry	31
11. Trigonometry	35
12. Calculus	20
13. Statistics	15
14. Principles of Real Estate	9
15. History 1	46
16. History 2	38
17. Ancient History	11
18. Philosophy	8
19. Middle Eastern Culture	9
20. History of Art	11
21. Biology	24
22. Chemistry	18
23. Physics	30
24. Spanish	21
25. French	18
26. German	14
27. Audio-Visual Lesson Materials	48
<u>Vocational Training</u>	
none	
TOTAL ANTICIPATED ENROLLMENT PER SEMESTER	724

EXAMPLE DESIGNS

DG 1110-3-112 May 1979

6-2 EXAMPLE DESIGN-SCHEME A FOR 6,000 MILITARY STRENGTH (cont'd)

Table 6-3 Example Projected Space Type Utilization

SPACE TYPE: CLASSROOM

Course Designation	Typical Semester Enrollment	Max Class Size	No. of Classes	Hrs/wk Ea. Class Meets	Hrs/wk Required
English 1	88 students	24	4	4	16
English 2	67	24	3	4	12
Algebra 1	47	24	2	5	10
Geometry 1	31	24	2	5	10
Trig 1	35	24	2	5	10
Arithmetic	38	24	2	5	10
Calculus	20	24	1	5	5
History 1	46	24	2	5	10
History 2	38	24	2	5	10
English Comp	60	24	3	4	12
TOTAL HRS/WK SPACE TYPE IS REQUIRED					C = 105

(5) Determination of Number of Each Space Type. The number of each type of space required is determined by using the formula $N = c/uh$ as set forth in Chapter 2 (para 2-5b(5)). Utilizing the "C" value established in Table 6-3, a 40 hour/week operation ("h" value), and a 0.8 utilization rate ("u" value), the number of classrooms required is determined as follows:

$$N = \frac{105}{0.8} \times 40; \quad N = 3.3$$

Rounded up to the nearest whole integer the number of classrooms required is 4. The same process is used to determine the number of other instructional spaces required for the total project. The types and number of academic spaces required for this example project are shown in Table 6-4. The occupant load is also identified in order to help determine the requirement for toilet fixtures later on.

6-2 EXAMPLE DESIGN-SCHEME A FOR 6,000 MILITARY STRENGTH (cont'd)

Table 6-4 Number of Academic Spaces Needed-Example

Type of Academic Space/Occupant Load Each	No. Required	Occupant Load
Classroom/25	4 req'd *; bal. = 2	50
Lecture Room/53	1	53
Seminar Room/13	3	39
MOS Library/9	1	9
Self-Paced Instruction/20	1	20
Language Lab/22	1	22
Science Lab/25	1	25
Testing Room/37 (as classrooms/50)	1	50
Rehearsal and Recording Studio/6	1	6
* Testing Room will serve as 2 classrooms		
Academic Occupant Load		274

(6) Survey of Existing Suitable Facilities. In this example, no space requirements can be subtracted since there are no existing facilities within eight-minutes walking distance that are suitable.

(7) Academic Space Requirements. By multiplying the number of spaces required for each space type times the NASF space allocated in Chapter 4, para 4-3, the total academic space required is determined as shown in Table 6-5.

Table 6-5 Academic Space Requirements-Example

Type of Space	No. of Spaces Required	x	NASF/Space Allocated	=	Total NASF
Classroom	2		750		1500
Lecture Room	1		1500		1500
Seminar Room	3		375		1125
MOS Library	1		750		750
Self-Paced Instruction	1		750		750
Language Lab	1		750		750
Science Lab	1		1500		1500
Testing Room	1		1905		1905
Reh/Rec Studio	1		375		375
Total Academic Space Required					10,155 NASF

EXAMPLE DESIGNS

DG 1110-3-112 May 1979

6-2 EXAMPLE DESIGN-SCHEME A FOR 6,000 MILITARY STRENGTH (cont'd)

(8) Staff Space Requirements. Based upon the staffing authorized (Table 6-1) and the space allowances stated in Chapter 4, para 4-2, the total staff space required is derived by multiplying the number of spaces required times the NASF space allocated as shown in Table 6-6.

Table 6-6 Staff Space Requirements-Example

Type of Space	No. of Spaces Required	x	NASF/Space Allocated	=	Total NASF
Director	1		200		200
Administrator	1		150		150
Clerk	1		100		100
Typist	2		75		150
Registrar	1		100		100
Information			150		150
Storage			75		75
Counselors	5		100		500
Reference			150		150
Total Staff Space Required					1575 NASF

(9) Support Space Requirements. Determination of support space requirements is based upon the percentages of combined NASF (for academic and staff spaces) and minimum allocations given in Chapter 4, para 4-5. Requirements for toilet facilities are based upon peak occupant load male/female ratio, fixture allocation, and unit space allowances (para 4-5.e.). In this example, the combined NASF is 10,155 + 1575; or 11,730. The peak occupant load is assumed to be 274 (academic) + 11 (staff); or 285. Computation of total support space required for this project is shown in Table 6-7.

Table 6-7 Support Space Requirements-Example

Type of Space	NASF/Space Allocated	Total NASF
Staff Lounge	1.5% x 11,730 NASF* (min 150 NASF)	175
Student Lounge	5.5% x 11,730 NASF (min 400 NASF)	645
Vending Area	3% x 11,730 NASF (min 300 NASF)	350
Training Aids Prep.	4% x 11,730 NASF (min 300 NASF)	470
Toilets (for 285**)	See para 4-5.e., Chapter 4	
Men (213)	6 WC, 5 UR, 9LAV	410
Women (72)	3 WC, 3 LAV	155
Receiving/Gen. Stor.	5% x 11,730 NASF (min 300 NASF)	585
Janitor Closet	1% x 11,730 NASF (rein 90 NASF)	120
TOTAL SUPPORT SPACE REQUIRED		2,910 NASF

*Combined NASF for academic and staff spaces

**Peak occupant load.

6-2 EXAMPLE DESIGN-SCHEME A FOR 6,000 MILITARY STRENGTH (cont'd)

(10) Gross Space Requirement. Gross space (GSF) is determined by allowing 15% of the total NASF for academic, staff and support spaces for circulation, exterior walls, etc. Since space for the building's mechanical equipment is not figured as part of the gross space, such space must be determined separately and added to the gross total. Table 6-8 summarizes the space requirements for this example.

**Table 6-8 Tabulated Space Requirements and Occupant Capacity
Example for Military Strength of 6,000**

	Load	SF
<u>Staff Spaces</u>		
Director	1	200
Administrator	1	150
Clerk	1	100
Typists (2)	2	150
Registrar	1	100
Information and Storage	—	225
Counselors (5)	5	500
Reference	—	150
Total Staff Capacity	11	1,575
<u>Academic Spaces</u>		
Classrooms (2)	50	1,500
Lecture Room	53	1,500
Seminar Rooms (3)	39	1,125
MOS Library	9	750
Self-Paced Instruction	20	750
Language Lab	22	750
Science Lab	25	1,500
Testing Room (2 classrooms)	50	1,905
Rehearsal/Recording Studio	6	375
Total Student Capacity	274	10,155
<u>Support Spaces</u>		
Staff Lounge		175
Student Lounge		645
Vending Area		350
Training Aids Preparation		470
Toilets—men		410
—women		155
Receiving/Gen. Storage		585
Janitor Closet		120
		2,910
Net Total		14,640 NASF
Net to Gross Space at 15%		2,195
Gross Total (maximum allowable target—16,920 GSF)		16,835 GSF
Mechanical Space		150

6-2 EXAMPLE DESIGN-SCHEME A FOR 6,000 MILITARY STRENGTH (cont'd)

d. DESIGN SOLUTION

(1) Basic Spatial Organization. Since this example project does not include vocational training spaces and must be designed to fit on a long, narrow site, a simple linear scheme, modified from the parallel and axial schemes is used. Primary access is provided at one end which adjoins the parking area as shown in Figure 6-1.

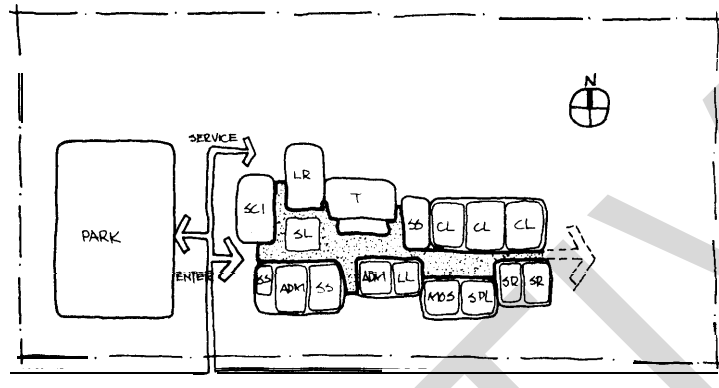

Figure 6-1 Basic Spatial Organization-Scheme A

(2) Example Plan. This example design is developed around two courtyards along the primary circulation spine as shown in Figure 6-2. The courtyards are used to create volumetric interest in conjunction with a set of viewing positions planned along the scheme. They are also used to provide natural light and greenery to the interior of the building, creating focal points around which various functional spaces are clustered. The information/registrar area is located adjacent to the main entrance to serve as a control point for the building. The student lounge is located on the circulation spine adjacent to the vending area and the lecture room for multi-use purposes. Counselor offices are centrally located for easy access from the main entrance to serve the needs of both students enrolled in courses and military personnel who come for counseling only. Toilets are placed at the approximate center of the circulation spine in order to best serve the entire building. Employing the basic 5-foot module system discussed in Chapter 3., the 25 ft x 30 ft (750 SF) module is utilized for all academic and staff spaces. The modules are offset at various points to create the interior courtyard spaces.

6-2 EXAMPLE DESIGN-SCHEME A FOR 6,000 MILITARY STRENGTH (cont'd)

- | | | |
|---|---|-------------------------------|
| 1. Entrance | 12. Classroom | 23. Vending Storage |
| 2. Director | 13. Seminar Room | 24. Men's Toilet |
| 3. Administrator | 14. Lecture Room | 25. Women's Toilet |
| 4. Clerk | 15. MOS Library | 26. Janitor's Closet |
| 5. Typists | 16. Self-Paced Instruction | 27. Receiving Room |
| 6. Information & Registration | 17. Science Lab | 28. General Storage |
| 7. Storage | 18. Language Lab | 29. Secondary Entrance |
| 8. Training Aids Preparation | 19. Testing Room and Related Facilities | 31. Landscape Court |
| 9. Counselors | 20. Staff Lounge | 32. Student and Staff Parking |
| 10. Conference Room | 21. Student Lounge | 33. Handicapped Parking |
| 11. Instructor's Rehearsal/Recording Studio | 22. Vending Area | 35. Service Area |

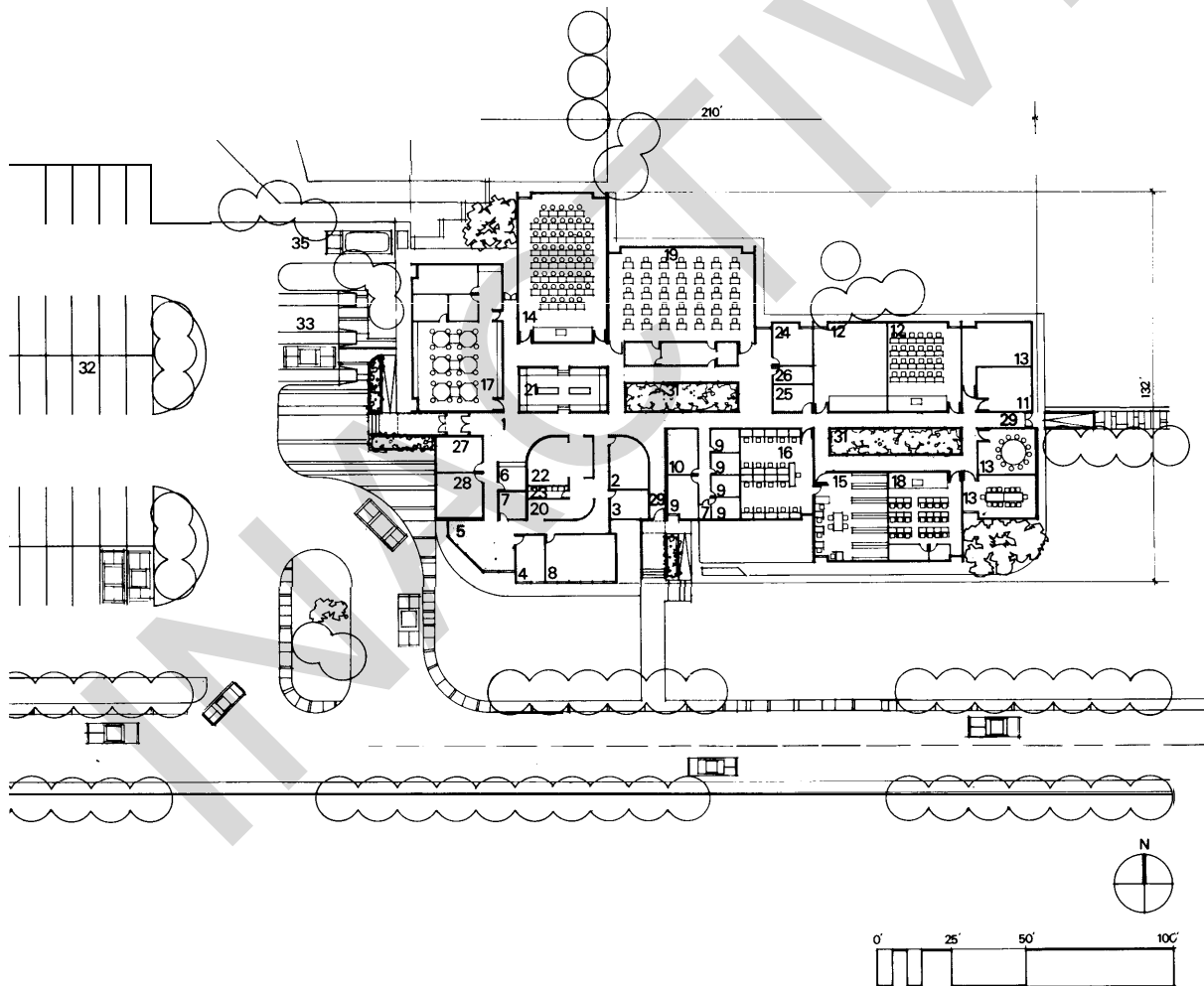

Figure 6-2 Example Plan-Scheme A Education Center for 6000 Military Strength

EXAMPLE DESIGNS

DG 1110-3-112 May 1979

6-3 EXAMPLE DESIGN-SCHEME A-1 FOR 6,000 MILITARY STRENGTH

a. **SITUATION.** The requirements of this project are similar to those for Scheme A. However, in this case, the installation is located in an area that is subject to more severe weather conditions, particularly in the winter. The site, which is immediately adjacent to the Main Library, is very small and narrow, with limited space for development of parking facilities. However, the parking spaces available on the library site can be shared with the ACES Center given proper access provided by good site planning.

b. **PLANNING.** The authorized space allowance and staffing, and the enrollment and usage of the ACES Center are the same as determined in Scheme A. The space requirements are the same as those indicated in Table 6-8.

c. **DESIGN SOLUTION.**

(1) Basic Spatial Organization. This ACES Center, basically organized as a simple linear/modified axial scheme, is dictated by the configuration of the site. Due to the limited site area and the space requirements of the program, a two-story scheme is necessary. The two-story configuration also helps conserve energy by exposing less building surface to the elements. An axis perpendicular to the main linear axis is desired to connect the new ACES facility to the existing library as shown in Figure 6-3.

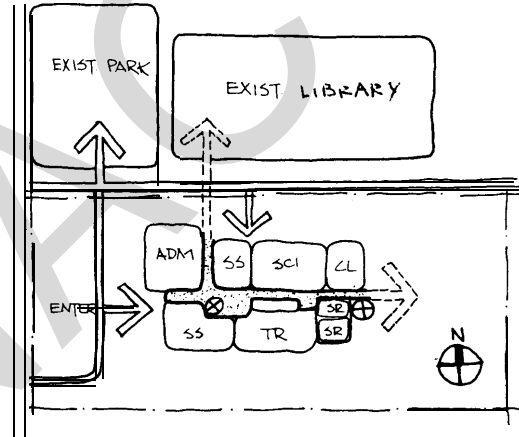

Figure 6-3 Basic Spatial Organization-Scheme A-1

(2) Example Plan. Staff and support spaces are located near the main and service entrances on the ground level as shown in Figure 6-4. Academic spaces are located on two floors with classroom, lecture room, MOS library and self-paced learning room located on the second floor, linked to the existing library. The 750 SF module again forms the basic layout system in this example solution.

6-3 EXAMPLE DESIGN-SCHEME A-1 FOR 6,000 MILITARY STRENGTH (cont'd)

- 1. Entrance
- 2. Director
- 3. Administrator
- 4. Clerk
- 5. Typists
- 6. Information & Registration
- 8. Training Aids Preparation
- 9. Counselors
- 11. Rehearsal/Recording Studio
- 12. Classroom
- 13. Seminar Room
- 14. Lecture Room
- 15. MOS Library
- 16. Self-Paced Instruction
- 17. Science Lab
- 18. Language Lab
- 19. Testing Room and Related Facilities
- 20. Staff Lounge
- 21. Student Lounge
- 22. Vending Area

- 23. Vending Storage
- 24. Men's Toilet
- 25. Women's Toilet
- 26. Janitor's Closet
- 27. Receiving Room
- 28. General Storage
- 29. Secondary Entrance
- 30. Elevator
- 32. Student and Staff Parking
- 33. Handicapped Parking
- 35. Service Area
- 36. Terrace
- 38. Open Space over Lounge
- 47. Connector to Existing Library

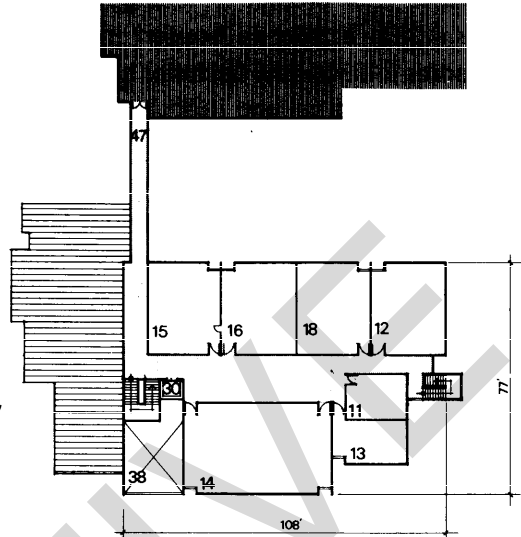

SECOND FLOOR PLAN

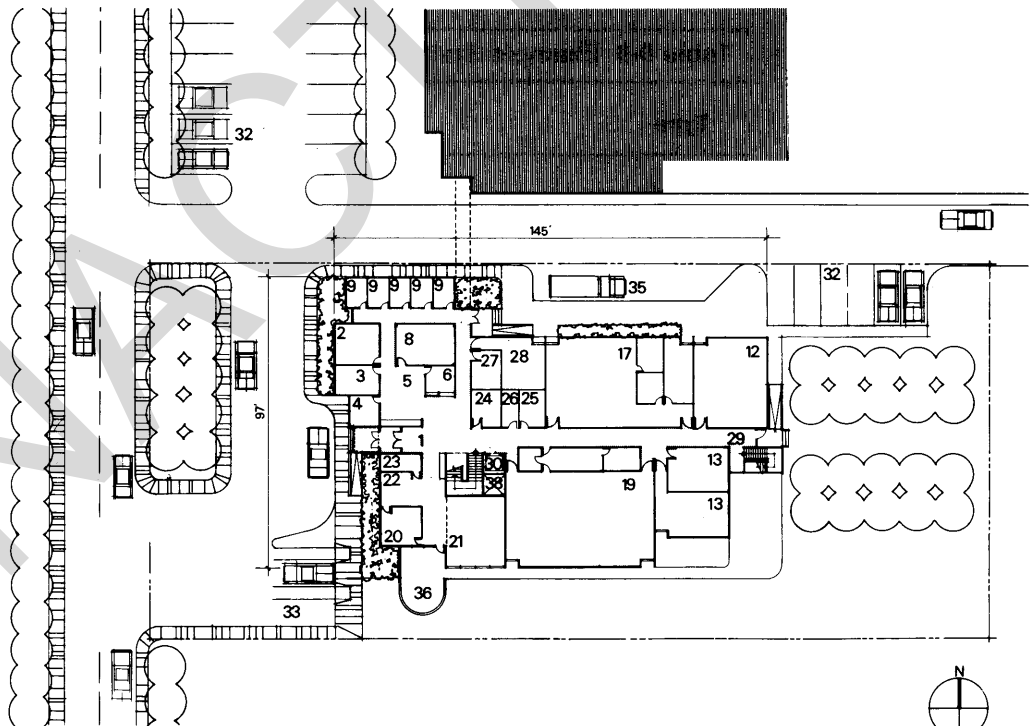

FIRST FLOOR PLAN

Figure 6-4 Example Plan-Scheme A-1— Education Center For 6,000 Military Strength

EXAMPLE DESIGNS

DG 1110-3-112 May 1979

6-4 EXAMPLE DESIGN-SCHEME B FOR 10,500 MILITARY STRENGTH

a. SITUATION. This project is located on an installation in the southwestern United States. Currently, the ACES activity is housed in several temporary buildings which are scheduled for demolition in order to build new bachelor housing. A new ACES Center site is identified on the master plan that is relatively large and irregular in configuration with a secondary road on the southern property line.

The ACES Program is projected to have a fairly constant scheduled enrollment of approximately 1050 people who will utilize facilities at various times during the week. Eventual growth of the Center is expected to take place primarily in the vocational training program. The Center will operate a full program five days per week and will offer a partial program on Saturday for a total operation of 48 hours per week.

b. PLANNING DATA

(1) Authorized Space Allowance. A 10,500 person (military strength) installation is allowed (Table 2-1) up to 27,440 GSF, excluding mechanical space, for an ACES Center.

(2) Staffing. Authorized staffing is shown in Table 6-9.

Table 6-9 Example Staffing For Military Strength Of 10,500

Type	No of Authorized Staff
Director	1
Administrator	2
Clerk	2
Typist	2
Registrar	1
Counselor	9
Total	17

(3) Gross Space Requirement. Table 6-10 summarizes the space required for this example. Although the computations are not shown in detail, the requirements are based on the staffing authorized in Table 6-9 and a projected enrollment and course requirement.

6-4 EXAMPLE DESIGN-SCHEME B FOR 10,500 MILITARY STRENGTH (cont'd)

**Table 6-10 Tabulated Space Requirements And Occupant Capacity
Example For Military Strength Of 10,500**

	Load	SF
<u>Staff Spaces</u>		
Director	1	200
Administrators (2)	2	300
Clerks (2)	2	200
Typists (2)	2	150
Registrar	1	100
Information and Storage	—	250
Counselors (9)	9	900
Reference	—	150
Total Staff Capacity	17	2,250
<u>Academic Spaces</u>		
Classrooms (2)	50	1,500
Lecture Room	53	1,500
Seminar Rooms (3)	39	1,125
Self-Paced Instruction	20	750
MOS Library	9	750
Language Lab	22	750
Science Lab	25	1,500
Testing Room (2 classrooms)	50	1,905
Rehearsal/Recording Studio	6	375
	274	10,155
<u>Vocational Training Spaces</u>		
Auto Body Repair Shop	20	5,075
Heating/Refrig/AC Shop	20	2,200
	40	7,275
Total Student Capacity	314	
<u>Support Spaces</u>		
Staff Lounge		185
Student Lounge		685
Vending Area		375
Training Aids Preparation		500
Toilets-218 men (410 SF), 73 women (155 SF)		565
Toilets-Vo. Training Area, 36 men (255), 4 women (1 10)		365
Receiving/Gen. Storage		620
Janitor Closet		125
		3,420
Net. Total		23,100 NASF
Net to Gross Space at 15%		3,465
Gross Total (maximum allowable target 27,440 GSF)		26,565 GSF
Mechanical Space		300

EXAMPLE DESIGNS

DG 1110-3-112 May 1979

6-4 EXAMPLE DESIGN-SCHEME B FOR 10,500 MILITARY STRENGTH (cont'd)

c. DESIGN SOLUTION

(1) Basic Spatial Organization. This solution is developed around an outwardly oriented, axial organization scheme as shown in Figure 6-5. This takes advantage of the irregular site configuration and natural ventilation possibilities.

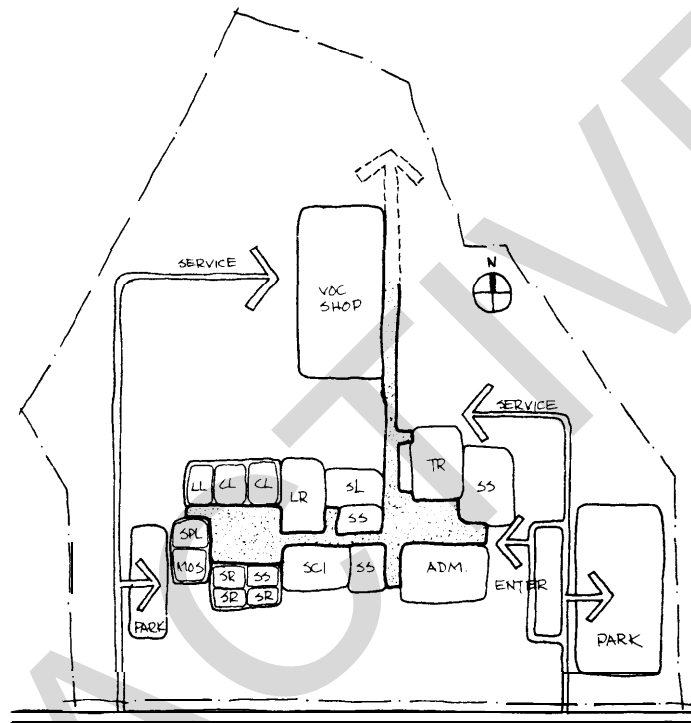

Figure 6-5 Basic Spatial Organization-Scheme B

(2) Example Plan. The plan radiates from a central student lounge space and courtyard near the main entrance. These spaces, and an additional courtyard in the academic area, provide volumetric rhythm to the space organization scheme and create focal points of natural light and greenery in conjunction with the viewing position/circulation paths. Staff, counseling, and support functions are located directly adjacent to the entrance area. The central student lounge space is adjacent to the lecture room and an outside demonstration area. Another, but smaller student lounge space, is adjacent to the vending area and outside terrace. Toilets are located near the center of the axis. Academic classrooms and laboratories are organized around the other interior courtyard. Vocational training shops are together in a separate structure connected to the academic/staff element by a covered pedestrian walkway. The 25 x 30 ft (750 SF) module forms the basic layout of the academic building. The larger 30 x 50 module has been used for the vocational training shops.

6-4 EXAMPLE DESIGN-SCHEME B FOR 10,500 MILITARY STRENGTH (cont'd)

- | | | | |
|---------------------------------|--------------------------------|---|--------------------------------|
| 1. Entrance | 8. Training Aids Preparation | 15. MOS Library | 28. General Storage |
| 2. Director | 9. Counselors | 16. Self-Paced Instruction | 29. Secondary Entrance |
| 3. Administrator | 11. Rehearsal/Recording Studio | 17. Science Lab | 31. Landscaped Court |
| 4. Clerk | 12. Classroom | 18. Language Lab | 32. Student and Staff Parking |
| 5. Typists | 13. Seminar Room | 19. Testing Room and Related Facilities | 33. Handicapped Parking |
| 6. Information and Registration | 14. Lecture Room | 20. Staff Lounge | 35. Service Area |
| 7. Storage | | 21. Student Lounge | 36. Terrace |
| | | 22. Vending Area | 37. Outdoor Demonstration Area |
| | | 23. Vending Storage | 39. Shop Toilets |
| | | 24. Men's Toilet | 40. HVAC Shop |
| | | 25. Women's Toilet | 44. Auto Body Repair Shop |
| | | 26. Janitor's Closet | 45. Auto Storage |
| | | 27. Receiving Room | 46. Fence |

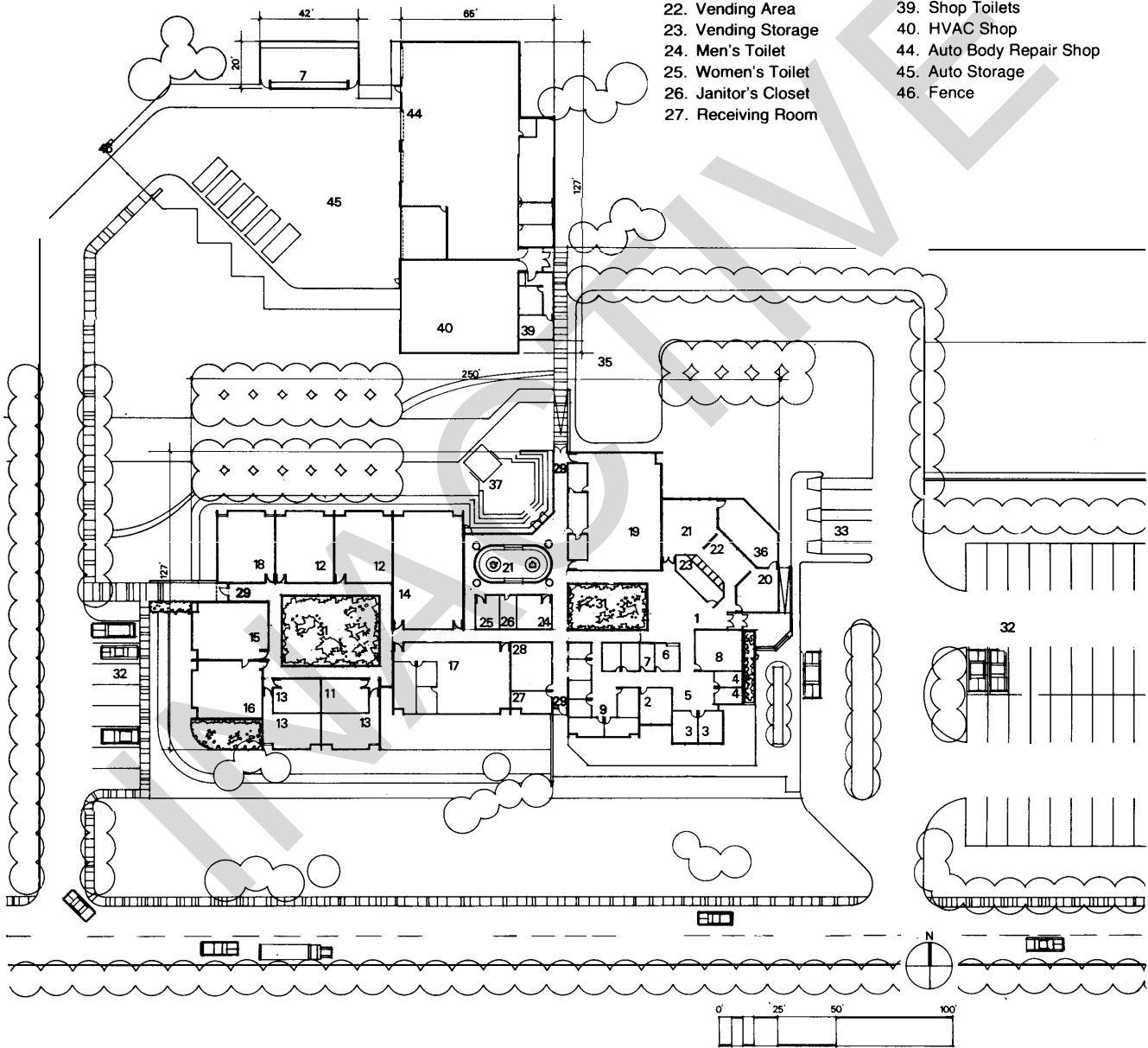

Figure 6-6 Example Plan Scheme-B—Education center for 10,500 Military Strength

EXAMPLE DESIGNS

DG 1110-3-112 May 1979

6-5 EXAMPLE DESIGN-SCHEME B-1 FOR 10,500 MILITARY STRENGTH

a. **SITUATION.** The mission, size and location of this project are the same as described in Scheme B, however, the site which has been designated on the master plan has a rock outcropping with a steep rise at the northeast corner which makes almost one-third of the site unusable. An existing library is located directly to the west.

b. **PLANNING.** The authorized space allowance and staffing, and the projected enrollment and usage of the ACES Center are the same as determined in Scheme B. The space requirements are the same as those indicated in Table 6-10.

c. **DESIGN SOLUTION.**

(1) Basic Spatial Organization. This solution is developed around a parallel organization scheme, as shown in Figure 6-7. Site features strongly influence the orientation of the scheme. Two parallel spines are developed; one for academic and staff spaces, and one for vocational training spaces. Requirements for parking space and for service and access to the vocational training area, make use of a two-story academic building desirable. Access to the main parking area runs between the academic and vocational training buildings.

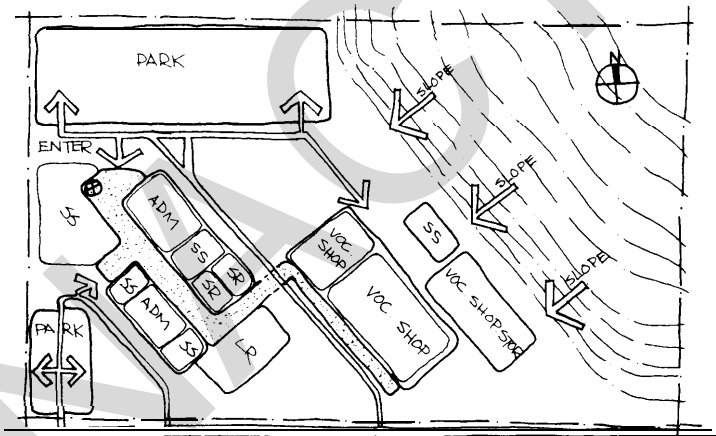
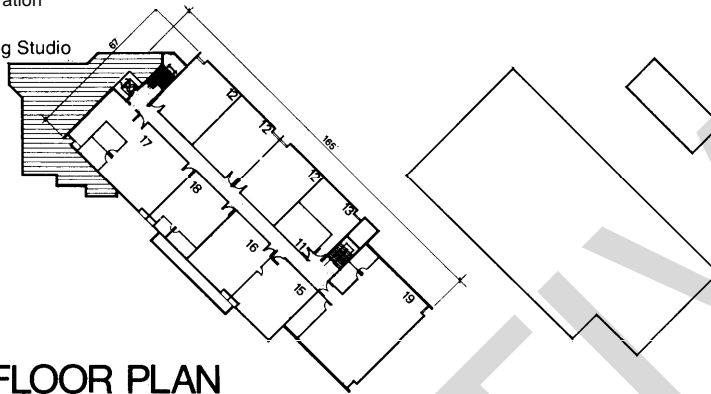

Figure 6-7 Basic Spatial Organization-Scheme B-1

(2) Example Plan. As shown in Figure 6-8, the main entrance to the academic building is from the main parking area. Principal staff spaces have been placed adjacent to the main and secondary entrances for control purposes. The vending area and lounges are also located in this area which is the primary node for vertical circulation. Counselors are located on the ground floor in proximity to the administrative area and the Director's office. Lecture room and seminar rooms are located at one end of the ground floor adjacent to the circulation flow between the academic and vocational training buildings. The other academic spaces are located on the second floor. The primary pedestrian

6-5 EXAMPLE DESIGN-SCHEME B-1 FOR 10,500 MILITARY STRENGTH (cent'd)

- | | | | |
|---------------------------------|--|----------------------|------------------------------------|
| 1. Entrance | 15. MOS Library | 21. Student Lounge | 27. Receiving Room |
| 2. Director | 16. Self-Paced Instruction | 22. Vending Area | 28. General Storage |
| 3. Administrator | 17. Science Lab | 23. Vending Storage | 29. Secondary Entrance |
| 4. Clerk | 18. Language Lab | 24. Men's Toilet | 30. Elevator |
| 5. Typists | 19. Testing Room and
Related Facilities | 25. Women's Toilet | 32. Student and Staff Parking |
| 6. Information and Registration | 20. Staff Lounge | 26. Janitor's Closet | 33. Handicapped Parking |
| 7. Storage | | | 34. Registration & Visitor Parking |
| 8. Training Aids Preparation | | | 39. Shop Toilets |
| 9. Counselors | | | 40. HVAC Shop |
| 11. Rehearsal/Recording Studio | | | 44. Auto Body Repair Shop |
| 12. Classroom | | | 45. Auto Storage |
| 13. Seminar Room | | | 46. Fence |
| 14. Lecture Room | | | |



SECOND FLOOR PLAN

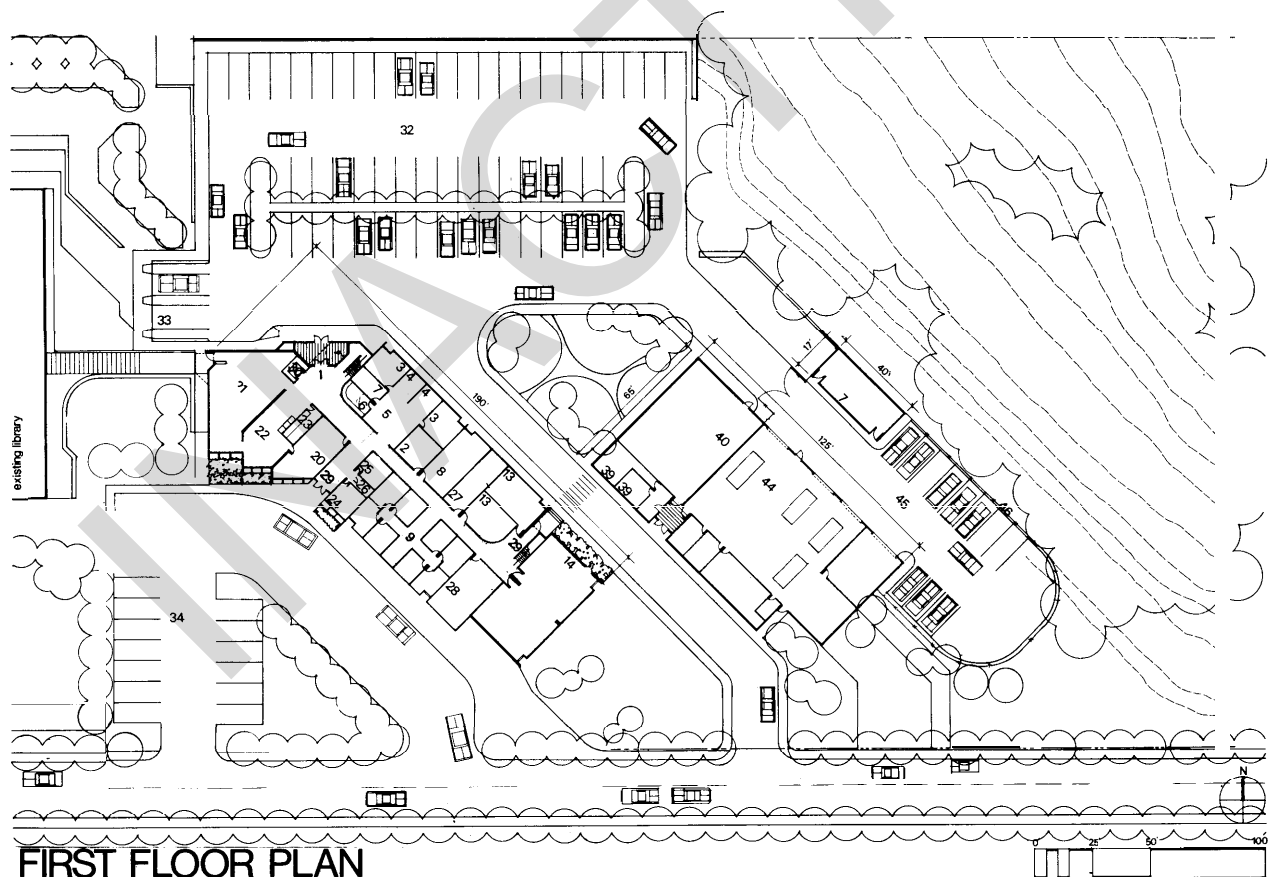

FIRST FLOOR PLAN

Figure 6-8 Example Plan Scheme B-1 - Education Center for 10,500 Military Strength

EXAMPLE DESIGNS

DG 1110-3-112 May 1979

6-5 EXAMPLE DESIGN-SCHEME B-1 FOR 10,500 MILITARY STRENGTH (cont'd)

entrance to the vocational training shops is from the access road with service access on the opposite side. The basic 25 x 30 ft module has again been used throughout the academic and staff building with the larger 30 x 50 ft module used for the vocational training shops. The lecture room and testing room have been stacked due to relative size. The diagonal orientation of the ACES Center to the existing library creates a strong visual relationship between the two buildings. To strengthen that relationship, the lounge spaces have been oriented on the same axis as the library with a covered pedestrian link between.

6-6 EXAMPLE DESIGN-SCHEME C FOR 21,000 MILITARY STRENGTH

a. SITUATION. This project is located on an installation in the southeast United States. The new ACES Center will replace a number of classroom facilities which are scattered in temporary structures throughout the installation. It will also supplement a vocational training unit which is located within a 10-minute walking distance. The site designated on the master plan is generous in size, with a primary road defining the site on the south. The long dimension of the site (approximately 750 ft) runs parallel to the road.

The use of the Center is projected to be high. Current enrollment in ACES programs is almost 1000. The projected semester enrollment will be approximately 1750. The ACES Center will operate on a 44 hour week, including evening and Saturday classes.

b. PLANNING DATA.

(1) Authorized Space Allowance. A 21,000 person (military strength) installation is allowed (Table 2-1) up to 38,080 GSF, excluding mechanical space, for an ACES Center.

(2) Staffing. Authorized staffing is shown in Table 6-11.

Table 6-11 Example Staffing for Military Strength of 21,000

Type	No. of Authorized Staff
Director	1
Administrator	3
Clerk	4
Typist	4
Registrar	1
Counselor	17
TOTAL	30

6-5 EXAMPLE DESIGN-SCHEME B-1 FOR 10,500 MILITARY STRENGTH (cont'd)

(3) Gross Space Requirement. Table 6-12 summarizes the space required for this example.

**Table 6-12 Tabulated Space Requirements and Occupant Capacity
Example for Military Strength of 21,000**

	Load	SF
<u>Staff Spaces</u>		
Director	1	200
Administrators (3)	3	450
Clerks (4)	4	400
Typist (4)	4	300
Registrar	1	100
Information and Storage	—	350
Counselors (17)	17	1,525
Reference	.	150
Total Staff Capacity	30	3,475
<u>Academic Spaces</u>		
Classrooms (4)	100	3,000
Lecture Room	53	1,500
Seminar Rooms (5)	65	1,875
Self-Paced Instruction	20	750
MOS Library	9	750
Language Lab	22	750
Science Lab	25	1,500
Testing Room (2 classrooms)	50	1,905
Rehearsal/Recording Studio	6	375
	350	12,405
<u>Vocational Training Spaces</u>		
Auto Mechanics Shop	20	5,850
Masonry Shop	20	4,150
Communications/Industrial Electronics Shop	20	2,525
	60	12,525
Total Student Capacity	410	
<u>Support Spaces</u>		
Staff Lounge		240
Student Lounge		875
Vending Area		475
Training Aids Preparation		635
Toilets – 286 men (500 SF) 95 women (200 SF)		700
Toilets – Vo. Training Area 54 men (415) 6 women (115)		530
Receiving/Gen. Storage		795
Janitor Closet		160
		4,410
Net Total		32,815 NASF
Net to Gross Space at 15%.		4,925
Gross Total (maximum allowable target – 38,080 GSF)		37,740 GSF
Mechanical Space		400

EXAMPLE DESIGNS

DG 1110-3-112 May 1979

6-6 EXAMPLE DESIGN-SCHEME C FOR 21,000 MILITARY STRENGTH (cont'd)

c. DESIGN SOLUTION

(1) Basic Spatial Organization. This solution is developed around the parallel organization scheme. Two linear spines are created parallel to each other, following the long dimension of the site as shown in Figure 6-9. The academic-staff area is developed along one spine and the vocational training shops are located along the other. Parking is located near the main entrance to the academic spaces with service access extending to the north side of the vocational training spaces.

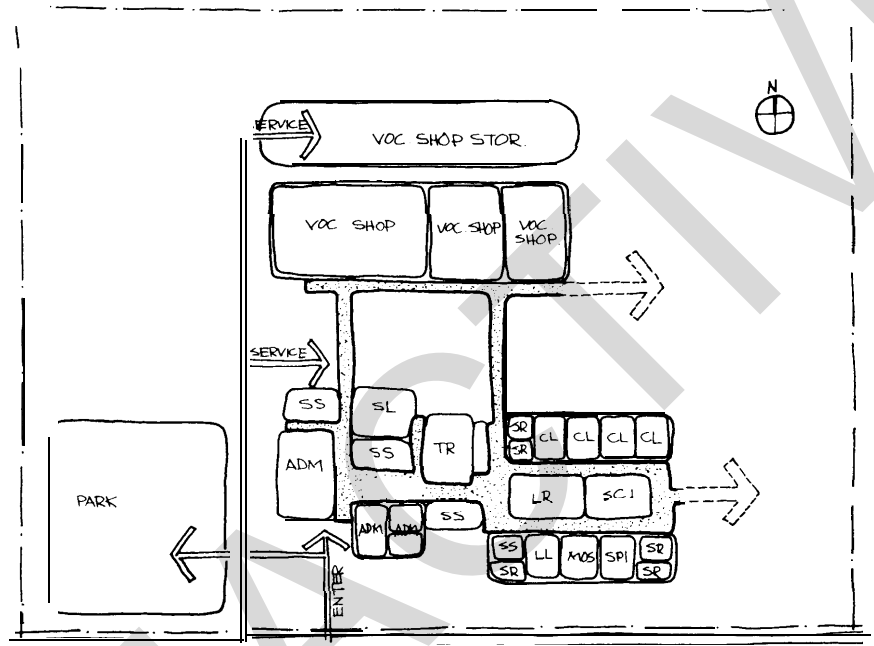

Figure 6-9 Basic Spatial Organization — Scheme C

(2) Example Plan. The academic-staff building is organized into two basic functional zones as shown in Figure 6-10; staff and support spaces are grouped around an interior court at the main entrance and academic spaces are grouped around the lecture room and science lab. The student lounge and the toilets are located near the main entrance and adjacent to the primary circulation flow between the academic building with the vocational training shops. The student lounge is oriented toward an outdoor terrace and landscaped instructional area between the two parallel buildings. Visual experiences are created in the circulation spaces of the academic-staff building by use of curved walls, proportional variation, and natural greenery to establish focal points and visual rhythm. The basic 25 x 30 ft module is used for the academic-staff spaces with the 30 x 50 ft module utilized for the vocational shops.

6-6 EXAMPLE DESIGN-SCHEME C FOR 21,000 MILITARY STRENGTH (cont'd)

- | | | |
|---------------------------------|--|---|
| 1. Entrance | 16. Self-Paced Instruction | 29. Secondary Entrance |
| 2. Director | 17. Science Lab | 31. Landscaped Court |
| 3. Administrator | 18. Language Lab | 32. Student and Staff Parking |
| 4. Clerk | 19. Testing Room and
Related Facilities | 33. Handicapped Parking |
| 5. Typists | 20. Staff Lounge | 35. Service Area |
| 6. Information and Registration | 21. Student Lounge | 36. Terrace |
| 7. Storage | 22. Vending Area | 39. Shop Toilets |
| 8. Training Aids Preparation | 23. Vending Storage | 41. Communications/Industrial
Electronics Shop |
| 9. Counselors | 24. Men's Toilet | 42. Masonry Shop |
| 11. Rehearsal/Recording Studio | 25. Women's Toilet | 43. Auto Mechanics Shop |
| 12. Classroom | 26. Janitor's Closet | 45. Auto Storage |
| 13. Seminar Room | 27. Receiving Room | 46. Fence |
| 14. Lecture Room | 28. General Storage | |

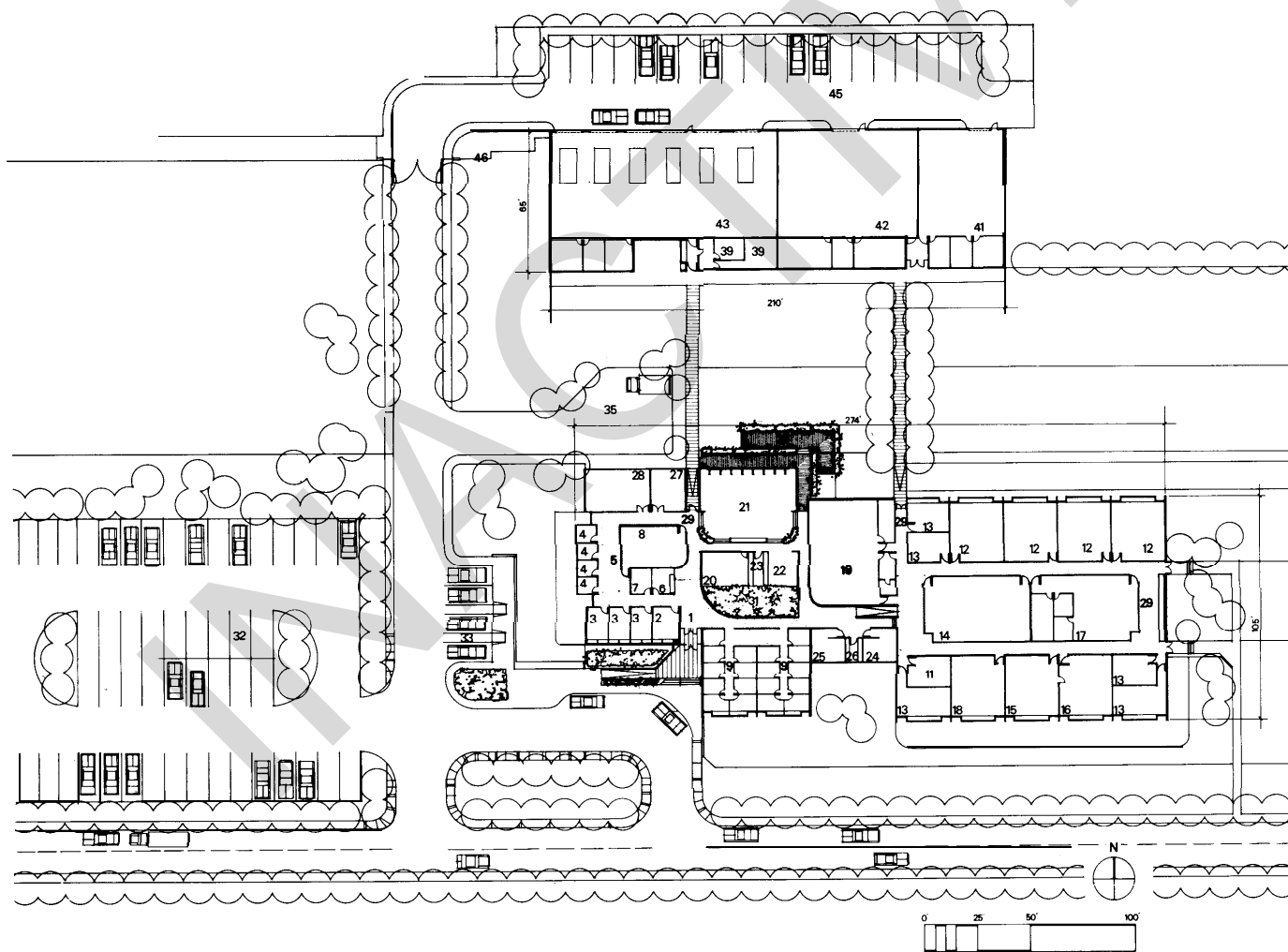

Figure 6-10 Example Plan-Scheme C - Education Center for 21,000 Military Strength

EXAMPLE DESIGNS

DG 1110-3-112 May 1979

6-7 EXAMPLE DESIGN-SCHEME C-1 FOR 21,000 MILITARY STRENGTH

a. **SITUATION.** The mission, size and location of this ACES Center project are the same as described in Scheme C, however, the site designated on the master plan is relatively small in size and triangular in shape. The site is bounded by a wooded area on the north and the primary road on the west. There are excellent views to the west.

b. **PLANNING.** The authorized space allowance and staffing, and the projected enrollment and usage of the ACES Center are the same as determined in Scheme C; the space requirements are the same as those indicated in Table 6-12.

c. DESIGN SOLUTION.

(1) **Basic Spatial Organization.** This solution is developed around a dispersed organization scheme as shown in Figure 6-11. The limited site area makes use of a two-story academic building desirable. Topographic features and views, in addition to site configuration, influence the spatial organization in this solution. The academic building is placed parallel to the road to take advantage of the views. Vocational training shops are developed on a spine perpendicular to the academic building. Main entry to the ACES Center is serviced by a loop road on the south. Service access to the vocational training area is provided by a road along the north side and center of the site.

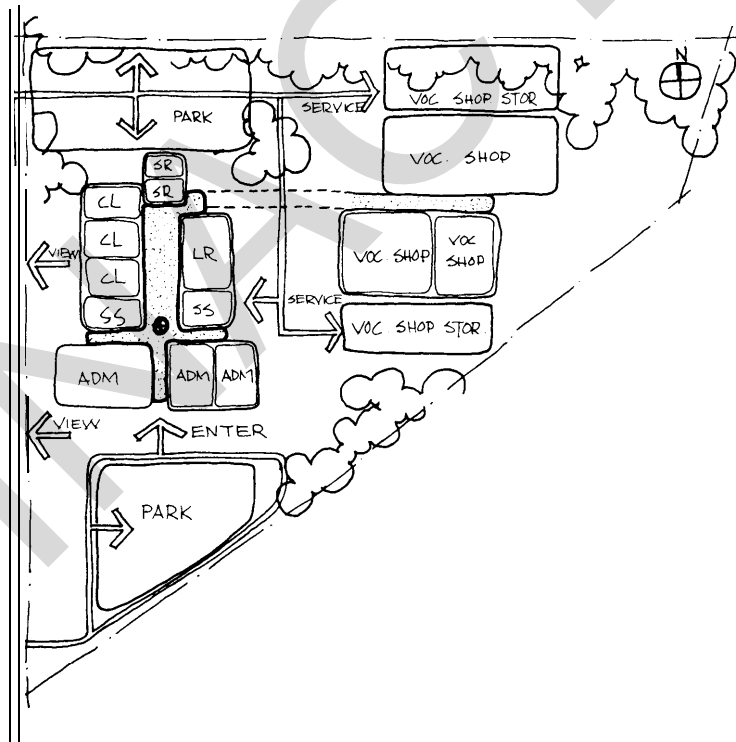

Figure 6-11 Basic Spatial Organization—Scheme C-1

6-7 EXAMPLE DESIGN-SCHEME C-1 FOR 21,000 MILITARY STRENGTH (cont'd)

(2) Example Plan. Two distinct structures have been developed as shown in Figure 6-12. A two-story academic building is developed around a high interior court and vertical circulation nodes with classrooms, staff offices, lounges and balcony-terrace located to take advantage of the view. Vocational training shops are organized along a double-loaded corridor with the ancillary functions, including toilets with showers and lockers, located on either side of the corridor. The basic 25 x 30 ft module is used in the academic building with the larger testing room, and its related spaces, stacked over a similiarized module containing the counselor offices. The 30 x 50 ft module is used for the vocational training spaces.

INACTIVE

EXAMPLE DESIGNS

DG 1110-3-112 May 1979

6-7 EXAMPLE DESIGN-SCHEME C-1 FOR 21,000 MILITARY STRENGTH (cont'd)

1. Entrance
2. Director
3. Administrator
4. Clerk
5. Typists
6. Information and Registration
7. Storage
8. Training Aids Preparation
9. Counselors
11. Rehearsal/Recording Studio
12. Classroom
13. Seminar Room
14. Lecture Room
15. MOS Library
16. Self-Paced Instruction
17. Science Lab
18. Language Lab
19. Testing Room and Related Facilities
20. Staff Lounge
21. Student Lounge
22. Vending Area
23. Vending Storage
24. Men's Toilet
25. Women's Toilet
26. Janitor's Closet
27. Receiving Room
28. General Storage
29. Secondary Entrance
31. Landscaped Court
32. Student and Staff Parking
33. Handicapped Parking
35. Service Area
36. Terrace
39. Shop Toilets
41. Communications/Industrial Electronics Shop
42. Masonry Shop
43. Auto Mechanics Shop
45. Auto Storage
46. Fence

6-7 EXAMPLE DESIGN-SCHEME C-1 FOR 21,000 MILITARY STRENGTH (cont'd)

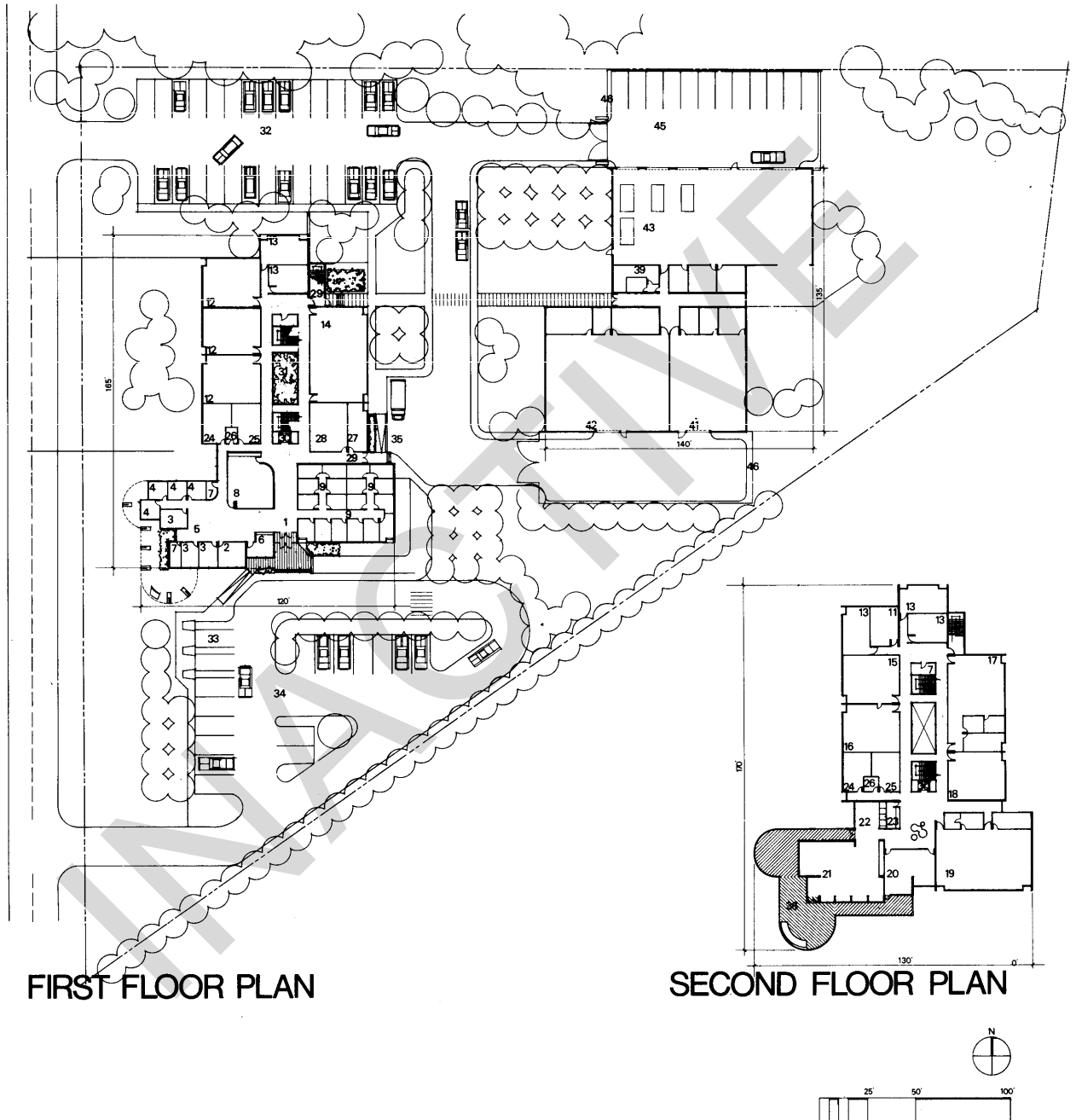

Figure 6-12 Example Plan—Scheme C-1—Education Center for 21,000 Military Strength