

UNIFIED FACILITIES CRITERIA (UFC)

AREA PLANNING, SITE PLANNING, AND DESIGN



APPROVED FOR PUBLIC RELEASE; DISTRIBUTION UNLIMITED

UNIFIED FACILITIES CRITERIA (UFC)

AREA PLANNING, SITE PLANNING, AND DESIGN

Any copyrighted material included in this UFC is identified at its point of use. Use of the copyrighted material apart from this UFC must have the permission of the copyright holder.

U.S. ARMY CORPS OF ENGINEERS (Preparing Activity)

NAVAL FACILITIES ENGINEERING COMMAND

AIR FORCE CIVIL ENGINEER SUPPORT AGENCY

Record of Changes (changes are indicated by \1\ ... /1/)

Change No.	Date	Location

This UFC supersedes TI 804-01, dated 1 July 1998. The format of this UFC does not conform to UFC 1-300-01; however, the format will be adjusted to conform at the next revision. The body of this UFC is the existing TI 804-01, dated 1 July 1998.

FOREWORD

v\

The Unified Facilities Criteria (UFC) system is prescribed by MIL-STD 3007 and provides planning, design, construction, sustainment, restoration, and modernization criteria, and applies to the Military Departments, the Defense Agencies, and the DoD Field Activities in accordance with [USD\(AT&L\) Memorandum](#) dated 29 May 2002. UFC will be used for all DoD projects and work for other customers where appropriate. All construction outside of the United States is also governed by Status of forces Agreements (SOFA), Host Nation Funded Construction Agreements (HNFA), and in some instances, Bilateral Infrastructure Agreements (BIA.) Therefore, the acquisition team must ensure compliance with the more stringent of the UFC, the SOFA, the HNFA, and the BIA, as applicable.

UFC are living documents and will be periodically reviewed, updated, and made available to users as part of the Services' responsibility for providing technical criteria for military construction. Headquarters, U.S. Army Corps of Engineers (HQUSACE), Naval Facilities Engineering Command (NAVFAC), and Air Force Civil Engineer Support Agency (AFCEA) are responsible for administration of the UFC system. Defense agencies should contact the preparing service for document interpretation and improvements. Technical content of UFC is the responsibility of the cognizant DoD working group. Recommended changes with supporting rationale should be sent to the respective service proponent office by the following electronic form: [Criteria Change Request \(CCR\)](#). The form is also accessible from the Internet sites listed below.

UFC are effective upon issuance and are distributed only in electronic media from the following source:

- Whole Building Design Guide web site <http://dod.wbdg.org/>.

Hard copies of UFC printed from electronic media should be checked against the current electronic version prior to use to ensure that they are current.

AUTHORIZED BY:

DONALD L. BASHAM, P.E.
Chief, Engineering and Construction
U.S. Army Corps of Engineers

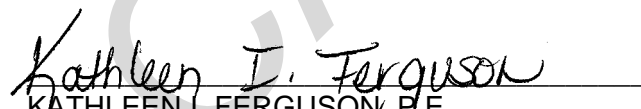
KATHLEEN I. FERGUSON, P.E.
The Deputy Civil Engineer
DCS/Installations & Logistics
Department of the Air Force

DR. JAMES W. WRIGHT, P.E.
Chief Engineer
Naval Facilities Engineering Command

Dr. GET W. MOY, P.E.
Director, Installations Requirements and
Management
Office of the Deputy Under Secretary of Defense
(Installations and Environment)

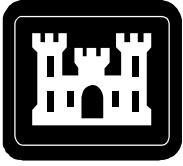

TI 804-01
1 July 1998

**US Army Corps
of Engineers®**

Technical Instructions

AREA PLANNING, SITE PLANNING, AND DESIGN

**Headquarters
U.S. Army Corps of Engineers
Engineering Division
Directorate of Military Programs
Washington, DC 20314-1000**

TECHNICAL INSTRUCTIONS

AREA PLANNING, SITE PLANNING, AND DESIGN

Any copyrighted material included in this document is identified at its point of use.
Use of the copyrighted material apart from this document must have the permission of the copyright holder.

Approved for public release; distribution is unlimited.

Record of Changes (changes indicated by \1\... /1/)

No.	Date	Page
-----	------	------

FOREWORD

These technical instructions (TI) provide design and construction criteria and apply to all U. S. Army Corps of Engineers (USACE) commands having military construction responsibilities. TI will be used for all Army projects and for projects executed for other military services or work for other customers where appropriate.

TI are living documents and will be periodically reviewed, updated, and made available to users as part of the HQUSACE responsibility for technical criteria and policy for new military construction. CEMP-ET is responsible for administration of the TI system; technical content of TI is the responsibility of the HQUSACE element of the discipline involved. Recommended changes to TI, with rationale for the changes, should be sent to HQUSACE, ATTN: CEMP-ET, 20 Massachusetts Ave., NW, Washington, D.C. 20314-1000.

TI are effective upon issuance. TI are distributed only in electronic media through the TECHINFO Internet site <http://www.hnd.usace.army.mil/techinfo/index.htm> and the Construction Criteria Base (CCB) system maintained by the National Institute of Building Sciences at Internet site <http://www.nibs.org/ccb/>. Hard copies of these instructions produced by the user from the electronic media should be checked against the current electronic version prior to use to assure that the latest instructions are used.

FOR THE COMMANDER:



KISUK CHEUNG, P. E.
Chief, Engineering and Construction Division
Director of Military Programs

TECHNICAL INSTRUCTIONS
AREA PLANNING, SITE PLANNING, AND DESIGN

Table of Contents

	Page
CHAPTER 1. INTRODUCTION	
Paragraph 1-1. PURPOSE AND SCOPE	1-1
1-2. APPLICABILITY	1-1
1-3. REFERENCES	1-1
1-4. DESIGN TEAM	1-1
CHAPTER 2. REQUIREMENTS	
Paragraph 2-1. GENERAL	2-1
2-2. PURPOSE	2-1
2-3. THE AREA DEVELOPMENT PLAN PROCESS	2-1
CHAPTER 3. THE SITE PLAN	
Paragraph 3-1. GENERAL	3-1
3-2. RELATIONSHIP TO THE AREA DEVELOPMENT PLAN	3-1
3-3. THE SITE PLANNING PROCESS	3-1
CHAPTER 4. DESIGN CRITERIA	
Paragraph 4-1. GENERAL	4-1
4-2. BUILDING DESIGN, LOCATION, AND ORIENTATION	4-1
4-3. VEHICULAR CIRCULATION AND PARKING	4-3

Table of Contents (continued)

	Page
Paragraph 4-4. PEDESTRIAN CIRCULATION	4-6
4-5. SURFACE WATER MANAGEMENT	4-10
4-6. UTILITY SYSTEMS DESIGN	4-11
4-7. LIGHTING DESIGN	4-11
4-8. LANDSCAPE DESIGN	4-11
4-9. PHYSICAL SECURITY	4-11

APPENDIX A REFERENCES	A-1
-----------------------------	-----

FIGURES

Figure	Title	
1-1	Planning hierarchy	1-3
2-1	The area development plan process	2-18
2-2	Functional relationships bubble diagram	2-19
2-3	Functional relationships matrix	2-19
2-4	Area land use	2-20
2-5	Area Transportation	2-20
2-6	Area utility supply lines	2-21
2-7	Analysis of natural environment	2-22
2-8	Analysis of built environment	2-22
2-9	Analysis of socio-cultural environment	2-23
2-10	Opportunities and constraints	2-23
2-11	Alternative 1 sketch plan	2-24

Table of Contents (continued)

	Page
2-12 Alternative 2 sketch plan	2-24
2-13 Alternative 3 sketch plan	2-25
2-14 Evaluation matrix	2-25
2-15 Preliminary area development plan	2-26
2-16 Location map	2-26
2-17 Final area development plan	2-27
2-18 Phasing Plan	2-28
3-1 Analysis of natural environment	3-10
3-2 Site opportunities and constraints	3-11
3-3 Alternative 1	3-12
3-4 Alternative 2	3-12
3-5 Alternative 3	3-13
3-6 Site evaluation matrix	3-13
3-7 Preliminary site plan	3-14
3-8 Final site plan	3-14
4-1 Dimensional factors	4-13
4-2 Solar orientation	4-14
4-3 Slope orientation	4-15
4-4 Wind orientation	4-15
4-5 Visual factors	4-16
4-6 Vehicular circulation	4-17
4-7 Parking	4-17

Table of Contents (continued)

	Page
4-8 Dumpster location	4-18
4-9 Pedestrian circulation patterns	4-18
4-10 Sidewalk plans	4-19
4-11 Minimize grading	4-20
4-12 Surface water management	4-20
4-13 Detention, retention, and infiltration principles	4-21
4-14 Erosion control	4-22

CANCELLED

CHAPTER 1**INTRODUCTION**

1-1. **PURPOSE AND SCOPE.** These Technical Instructions (TI) describe the Area Development Planning (ADP) and Site Planning processes to be used in preparing plans for construction drawings. The instructions are intended to be used by those individuals given the responsibility for site planning which includes site selection, site development, and site design. The planning procedures that occur in developing a project are described in these instructions. The procedures described are sound and provide a logical process to the end result.

a. **Area Development Plan.** The ADP is described as providing facility planning at the small area or sub-area level which falls between master planning for an entire installation (RPMP) and site planning for individual buildings (see figure 1-1). The ADP process includes the phases--Identification, Evaluation and Implementation. Identification includes defining the goals and objectives, verifying the program requirements, developing functional relationships, defining spatial relationships, providing an inventory of the area and accomplishing a site visit. Evaluation includes the development of a site analysis that graphically shows the developmental opportunities and constraints for the area. Alternative conceptual plans are developed for evaluation and a determination of a final area development plan is accomplished. Implementation includes the procedures of the Army military construction program for development and execution.

b. **Site Plan.** Site planning is described as further defining the functional layout for specific buildings or functions and their site. It also includes the phases--Identification, Evaluation, and Implementation. Identification includes defining site specific goals and objectives, verifying the program requirements, developing functional relationships, defining spatial relationships, providing an inventory of the area and accomplishing a site visit. Evaluation includes the development of a site analysis that graphically shows the developmental opportunities and constraints for the site. Alternative conceptual plans are developed for evaluation and a determination of a final site plan is accomplished. The resulting site plan provides the basis for the preparation of construction drawings. Implementation includes the procedures of the Army military construction program for development and execution. The design criteria discusses building design, location and orientation, vehicular circulation and parking, pedestrian circulation, surface water management, utility systems design, lighting design, landscape design, and physical security.

1-2. **APPLICABILITY.** These instructions are applicable to all USACE elements involved in preparing plans for areas, sites, and facilities for Army and civilian installations.

1-3. **REFERENCES.** References used in these instructions are identified in appendix A.

1-4. **DESIGN TEAM.** The ADP and site planning processes should be the responsibility of an interdisciplinary team of design professionals (see ER 1110-1-8152, Professional Registration). This multi-professional approach to the planning process helps assure that all aspects of the man-made and natural characteristics of the area being planned are properly and thoroughly considered (see ER 1110-1-12, Engineering and Design Quality Management). Plans are prepared to provide a comprehensive solution to the program requirements addressing environmental assessment of actions, design quality, and economic efficiency.

The interdisciplinary team should be identified at the beginning of the planning process so that its expertise can be applied from the outset. The membership of the team and the team leader will be determined by the functional requirements of the project. There are typically four major components of a planning and design team: landscape architecture, land planning, civil engineering, and architecture. The landscape architect may take the lead role because of the expertise required in area and site planning. Other professionals such as mechanical and electrical engineers, hydrologists, geologists, and historic preservationists may be included in the planning process as warranted by specific conditions. Intended users and other citizens should also be involved throughout the process. User input is critical to the success of the plan.

CANCELLED

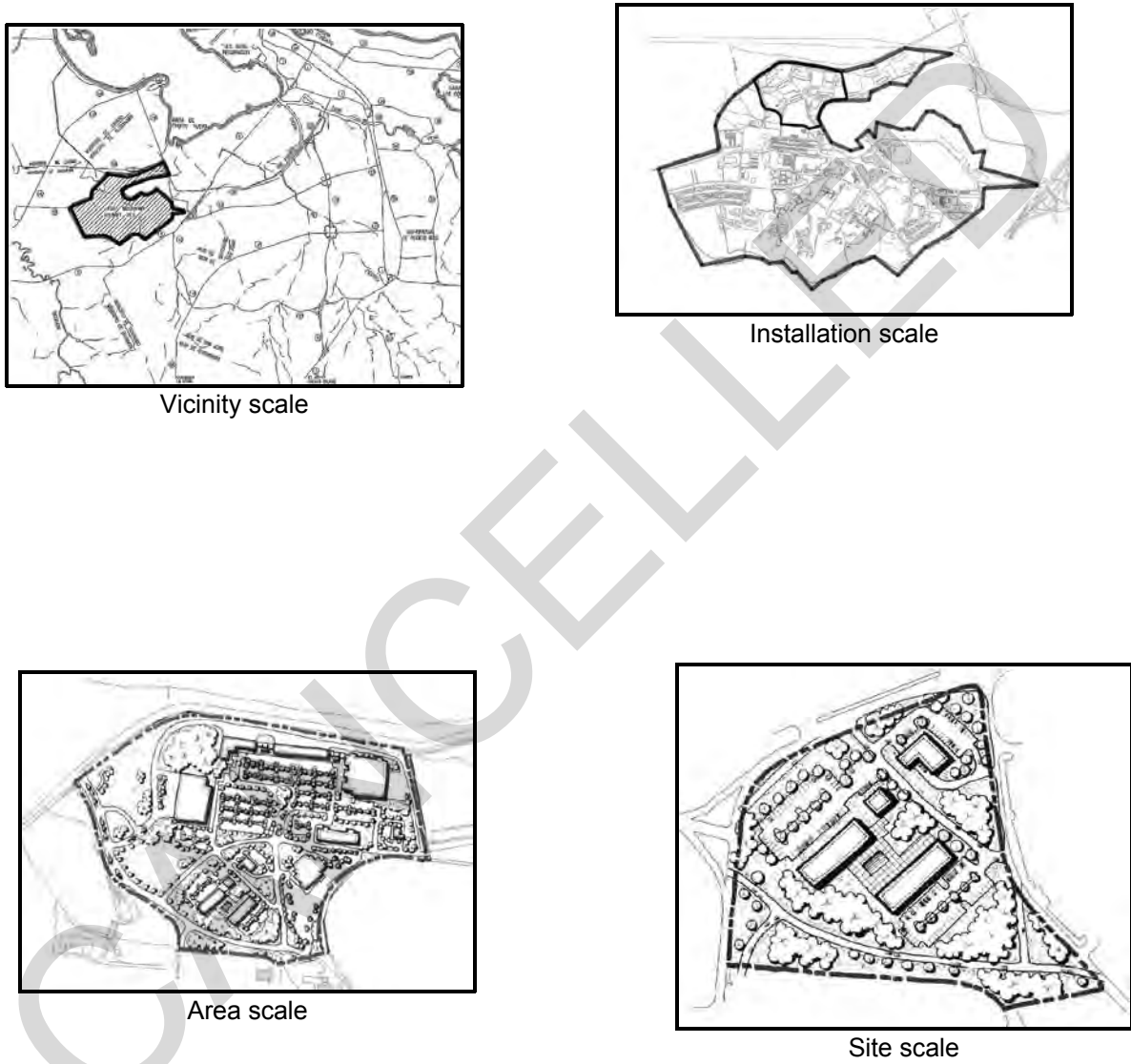

Figure 1-1. Planning Hierarchy

CHAPTER 2

THE AREA DEVELOPMENT PLAN

2-1. GENERAL. This chapter provides guidance for the preparation of an Area Development Plan (ADP). The ADP is a process used to prepare a planning framework for areas that consist of complex or incompatible functions or functions requiring large areas of land which impact circulation and utilities. It may include a number of individual buildings or activities with common elements associated by function such as administration facilities or barracks facilities, or facilities that differ in use but are associated by proximity.

2-2. PURPOSE. The ADP provides for the definition of program requirements by coordinating the location of buildings, vehicular and pedestrian access, parking, open space and other activities or facilities within the area. The end result of the process is a plan for the area both in written and graphic format. It describes the planning process, presents an efficient, economic and functional plan and provides direction for implementing the plan. Graphics are of primary importance throughout the plan to communicate the design intent and planning principles that are proposed for the area. The Final Area Plan is a graphic illustration of all of the elements proposed to occur within the area boundaries. The plan also includes details or sketches to illustrate important land use, circulation, and utilities. The plans, text, and graphics provide a framework that defines an efficient, economic, and functional area. The actual configuration of the individual sites can then be further refined in the Site Planning process described in chapter 3. The area development process uses urban design principles to integrate incompatible land uses and functional requirements within the existing manmade and natural environment.

2-3. THE AREA DEVELOPMENT PLAN PROCESS. The ADP process is designed to occur in a series of steps or actions that result in a Final Area Development Plan. The process is illustrated by the flow chart in figure 2-1. The process involves standard land use planning practices in three major planning phases: Identification, Evaluation, and Implementation. The process is sequential and designed to be followed from beginning to end. Area boundaries and general decisions as to how and by whom the area will be used should have been defined in the Real Property Master Plan. If not, the selection of area boundaries will be determined before the ADP process can begin. For this document, an Area Development Plan for a Community Center will be developed to illustrate the sequence of steps included in the process.

a. Identification. The identification phase includes the setting of goals and objectives, defining facility and spatial requirements, defining functional relationships, and the collection of base maps and data.

(1) Goals and Objectives. The first step in the area development plan process is to define project goals and objectives and installation development goals. Goals and objectives for the project are derived from the user mission. The user mission should be reviewed carefully to determine how the proposed project is intended to accomplish or support the mission.

(a) The user's specific needs will be determined for the following:

- 1/ Functional requirements
- 2/ Creation of organizational efficiency and safety
- 3/ Relationship to adjacent functions
- 4/ Contribution to the quality of life of the occupants

(b) The project goals and objectives become guidelines for the planning process. Goals are general, while objectives define specific actions to achieve the goals. The following goals and objectives are representative of what might be developed for an Installation Community Center ADP. They are based upon the installation goals as stated in the Real Property Master Plan:

1/ Goal: Plan an Installation Community Center that maximizes functional relationships between uses and the interior and exterior spaces.

a/ Objective 1: Locate buildings and parking to provide for ease of access and minimal walking distances.

b/ Objective 2: Provide for centrally located exterior space, away from traffic, that will serve as a meeting area for informal gatherings and lunch-time activity.

c/ Objective 3: Provide for pedestrian access, protected from the weather, that links the various buildings, exterior spaces and parking.

2/ Goal: Provide for direct, safe and easy vehicular and pedestrian access to the Installation Community Center.

a/ Objective 1: Provide most direct access from the Main Gate and from all parts of the installation via collector streets.

b/ Objective 2: Minimize conflicts of vehicular traffic and pedestrian access in parking lots.

c/ Objective 3: Provide for separation of customer traffic and delivery traffic.

(2) Facility and Land Area Requirements. Once the goals and objectives have been adopted, the development requirements and the spatial needs of these requirements can be identified. Accurate project requirements are fundamental to organizing and locating project elements on site. Failure to anticipate true programmatic and spatial needs can create incompatible land use and inefficient spatial arrangements, especially on small or confined sites. The land area or spatial requirements are determined by the size of the various facilities and other activities to be included within the area to serve the facilities such as driveways, walkways, parking and open space. Functional requirements are based upon the number of

employees to be housed within the facility. As an example, The following list defines the activities to be included in the Community Center ADP.

- (a) Commissary.
- (b) Guest housing.
- (c) Credit union.
- (d) Bank.
- (e) Convenient parking for new facilities.
- (f) Safe, convenient vehicular circulation.
- (g) Open space for separation of activities.
- (h) Open space for future development.
- (i) Safe, convenient, direct access for service vehicles.
- (j) Separate pedestrian and vehicular circulation.
- (k) Protect environmentally sensitive areas.

(3) Functional Relationships. The functional relationships of the proposed facilities must be defined so that they can be organized within the plan. This process consists of analyzing the interactions between facilities and activities to determine whether a given pair need to be linked or separated in order to function properly and be compatible.

(a) Functional Relationship Diagrams. The desired functional relationships are defined graphically through the use of Functional Relationships Diagrams. These diagrams organize facilities into ideal arrangements, based upon their interdependence. The diagram delineates the best locations for facilities in relation to each other, irrespective of site considerations. These diagrams can be developed as matrices or as "bubble diagrams". The two types of functional relationships diagrams are illustrated in figures 2-2 and 2-3 and further defined as follows:

1/ Bubble Diagrams are drawn to scale to define the size of the various activities as well as their interrelationships. In a bubble diagram, each bubble is connected with lines which illustrate the importance of the relationship to each other and whether connection or separation is appropriate. The bubble diagram approach is recommended because it provides a visual analysis of the desired relationships. The result of the bubble diagrams is a spatial relationship of the functional requirements. This relationship determines if the program requirements fit on the selected site. A bubble diagram may be developed through the following steps:

- a/ Delineate the approximate size of the primary facility in a bubble or block.

- b/ Delineate the approximate size of support facilities into bubbles or blocks.
- c/ Arrange the bubbles or blocks of primary and support facilities for optimal support.
- d/ Delineate necessary connection and separation between facilities using weighted lines.
- e/ Delineate major vehicular access and circulation with weighted lines with arrows to indicate access points and direction of traffic flow.
- f/ Delineate major pedestrian access and circulation using weighted lines and arrows.
- g/ Delineate future facilities and circulation using dashed lines.
- 2/ A matrix compares facilities or activities numerically or symbolically.

(4) Base Map and Data Collection. The inventory of area data will typically occur simultaneously with the analysis of project requirements and functional relationships. This inventory includes the collection of base maps and data about the environmental and manmade characteristics of the area and its environs. Existing maps and other data should be used whenever possible to prevent duplication of information. The data to be collected should include the following:

(a) Base Maps. The base maps to be used for preparing ADP maps and plans will typically be prepared at a ratio of 1:2000. These scales may vary depending upon the size of the area or degree of detail being provided. The following will be collected or prepared:

1/ Area Base Map. The Area Base Map provides specific data about the area and will be used as a base sheet upon which subsequent maps will be developed. Information typically provided on an Area Base Map includes existing structures; roadways, driveways, parking and walkways, topography, streams, water bodies, vegetation, fence lines, location of utilities, and other significant information. The map will be drawn to scale and will show a north arrow.

2/ Vicinity Map. The Vicinity Map includes the area development boundary and the surrounding areas. Coverage and detail in this map will vary depending upon the size and complexity of the area. The Vicinity Map includes much of the same information as the Site Base Map, but is prepared at a smaller scale to include more area. It is also drawn to scale and showing a north arrow.

3/ Location Map. The Location Map shows the location of the area development in a regional context. The map should be drawn at a very small scale to show the relationship of the site to the region. Typically, this would include the installation boundaries and major roadways within the installation and outside the installation, and major natural features such as an ocean, river or mountain range.

4/ Other Maps. Aerial photographs, Soil Conservation Service soil surveys, and USGS topographic surveys generally provide important data about the area.

(b) Data Collection. Data to be collected falls into three broad categories corresponding to the three environments in which people live, work, and play: the natural environment, the built environment, and the socio-cultural environment. Data to be collected will vary for each project. Data most often required for the successful development of an Area Development Plan is listed below.

1/ Background data such as the Real Property Master Plan, the Installation Design Guide, installation reports, and user input information.

2/ Environmental features such as topography, hydrology (wetlands, ground water, surface water, drainage ways, etc.) and soils.

3/ Tree surveys, including the location, common and botanical name, size and condition of all trees.

4/ Physical features such as existing buildings, utilities (including current use and capacities), roadways (including current use and capacity), driveways, parking, pedestrian walkways, fences, and easements.

5/ Significant architectural or historical features.

6/ Significant climatic conditions such as wind, sun, and precipitation.

7/ Significant views to be enhanced or obscured.

8/ Proposed modifications or changes that will impact the area.

(5) Site Visit. A site visit is an essential part of data collection. No other task provides as much useful information with which to better understand the overall area impacts. It provides a visual assessment of features such as architectural character, significant views, landscape character, and prominent land features. The site visit provides the opportunity to accomplish the following:

(a) Review and verify existing information. Photography, field sketches, and notation are commonly used methods of recording information.

(b) Evaluate the compatibility of existing on- and off-site conditions.

(c) Discover previously unknown or unrecorded conditions and factors.

(d) Evaluate the design qualities and visual qualities of the site.

b. Evaluation. The evaluation phase of the ADP includes the analysis of the data collected in the Identification phase.

(1) ADP Site Analysis. The area site analysis includes verifying and recording collected data in a series of maps, charts and text that document all existing conditions, both within and outside the area. This information provides a basis for the evaluation of the impacts that the existing conditions will have on-site development. All collected data and analysis results should be well documented. The analysis will be accomplished by overlaying the topographic map with transparencies of soils, hydrology and vegetation maps to define the natural conditions of the site. All manmade elements such as buildings, roadways, and utility lines should be overlaid on the natural conditions. This series of maps define the development potential of the area. During the analysis, it is important to understand the impacts various elements can have on the area. It is also important to know how these elements interrelate and are impacted by one another. The following elements should be evaluated:

(a) Off-Site Conditions. An area development is influenced by factors adjacent to the site. Both existing conditions and future development should be considered. The following elements should be evaluated for potential impacts and especially potential connections with the area development.

1/ Land Use. Surrounding land use should be recorded and the land use category verified (see figure 2-4).

2/ Transportation. All existing and proposed vehicular transportation systems to and around the area should be located and evaluated for their hierarchy and current operating capacity. Primary and secondary roadways should be examined to determine access points, traffic loads and vehicular safety requirements. All parking areas should be recorded. Bus routes and loading zones should be identified (see figure 2-5). A Site Traffic Impact Analysis for the area may be prepared.

3/ Utilities. All primary utilities and utility lines should be located and the size of the lines, capacities of generation, and current and projected utilization identified (see figure 2-6). The utilities include:

a/ Water system with locations of fire hydrants.

b/ Sanitary sewer system.

c/ Storm drainage system and drainage basin with invert elevations.

d/ Electrical, gas, and steam systems.

e/ Telephone system.

f/ Other types of communication systems or specialized utility systems.

4/ Environmental Conditions and Hazards. All areas or conditions of environmental concern near the area should be recorded. AR 200-2 and AR 415-15 provide further guidance on assessing environmental conditions.

a/ Storm drainage patterns indicating watershed boundaries and the direction of flow.

b/ Storm water management areas.

c/ Flood plain.

d/ Wetland areas.

e/ Wildlife habitats (especially for threatened and endangered species).

f/ Buried tanks, Installation Restoration Program (IRP).

g/ Other hazards.

5/ Historic, Cultural and/or Archeological Resources. All structures or sites that have been defined as historically, culturally or archeologically significant in the vicinity of the area should be identified.

6/ Safety Hazards. All requirements and distances necessary for safety such as fire codes, flood control, airfield and helipad clear zones, and explosives safety should be identified.

7/ Physical Security. Coordinate the physical security requirements with the Physical Security Plan of the installation. Existing or potential threat, high risk targets, and current vulnerabilities to deter attack should be determined by consulting the Provost Marshal.

8/ Sources of Air, Noise and Light Pollution. Immediate or point sources of pollution should be identified and their impact upon the site evaluated. Information may be found in the environmental impact assessments for the installation. The need and potential for achieving mitigation should be indicated. Non-point sources of pollution entering or leaving the area development should also be evaluated.

9/ Visual Enclosure. The area's viewshed (area of visual enclosure) extends beyond the area boundaries. The degree to which the surrounding environment contributes to the area's sense of enclosure or openness, may create desirable or undesirable views from the area. There may need to be buffers for the area's own visual condition.

(b) On-Site Conditions. All factors within the area boundary should be recorded. Both existing conditions and future development should be considered. Each factor is analyzed and recorded as part of the Natural Environment Analysis (figure 2-7), the Built Environment Analysis (figure 2-8), or the Socio-cultural Environment Analysis (figure 2-9). The following elements should be examined to evaluate potential impacts and connections within the area development.

1/ Geology. Geological conditions above and below the ground surface should be evaluated for the type of rock and its geologic formation.

2/ Topography. Existing elevations, high points, low points, and slopes should be defined. Slopes are usually described by their percent grade and placed in appropriate ranges (e.g., 0-5%, 5-10%, 10-20%, etc.).

3/ Hydrology. A hydrologic assessment provides information on surface and subsurface water movement. This information can be used to prevent flooding, erosion, and pollution of surface and groundwater and to promote groundwater recharge, habitat development, and recreational use.

a/ Subsurface. Subsurface hydrology concerns the storage and movement of water beneath the soil surface. Groundwater moves through the soil and through aquifers. Because aquifers are potential sources of potable water, federal, state and local agencies may regulate the quantity and quality of water allowed to infiltrate the ground surface. If a site is in a groundwater recharge area, there may be restrictions upon the amount of impermeable surface to be implemented and upon the water quality allowed for infiltration.

b/ Surface. Existing surface water bodies such as rivers, lakes, ponds, streams and springs should be recorded. Drainage patterns, flood plains, impermeable surfaces (pavements and rooftops) and other conditions affecting the movement of surface water should also be recorded. Significant information should be depicted graphically.

4/ Soils. Soils types and locations should be recorded and depicted graphically. The development potential of each type should be defined.

5/ Climate. A complete climatic evaluation of the site should be defined. Climatic conditions affect such planning concerns as building location and orientation, pedestrian circulation, and vegetation. The following information should be obtained and evaluated:

a/ Average monthly temperature range.

b/ Quantity, frequency, and type of precipitation.

c/ Midwinter and midsummer sunrise and sunset orientation and angle.

d/ Prevailing wind direction throughout the year.

6/ Vegetation. The location of all existing trees should be shown graphically. The trees should be located by survey and identified by common and botanical name, size and condition. Identification of local plant associations provide information on the types of tree and understory plant material which thrive in the area and should be used for landscape design applications when the area is developed.

7/ Wildlife Habitat. Natural wildlife habitats within the development area should be identified. Threatened and endangered species habitat requires protection.

8/ Archeological, Cultural and Historic Resources. Structures or sites that have been defined as historically, culturally or archeologically significant should be identified.

Those requiring preservation will have a significant impact on the development potential of the area.

9/ Visual Survey. An evaluation of the visual character of the area. This evaluation is made during the site visit and attempts to capture the feeling or essence of the area. Aspects of the assessment including the following:

a/ General geologic, topographic and vegetative character.

b/ Visual character of the site including view boundaries, good and poor site-specific views and their potential for enhancement or mitigation, and special visual features which define the character of the site or make a strong visual impact. Examples include: water bodies, mature tree specimens, rock outcrops, and sunlight and shadow.

c/ Sensory information such as odor, noise, or open or confined spaces.

d/ Microclimate conditions, such as warm or cold areas.

(2) Opportunities and Constraints. The evaluations made in the area site analysis are recorded on a map that summarizes the opportunities and constraints for development (figure 2-10). The opportunities and constraints evaluation is used to verify the adequacy of the area for the proposed project.

(a) The opportunities and constraints map interprets area features as either opportunities to be explored and enhanced or constraints to be avoided or mitigated. Opportunities and constraints maps should define the following:

1/ Natural features to be preserved for environmental protection.

2/ Natural features to be conserved.

3/ Natural features that affect construction (poor soils, steep slopes, etc.).

4/ Climatic impacts of temperature, solar radiation, wind, and precipitation.

5/ Existing structures or other landmarks to be preserved or enhanced because of historic, architectural, or other significance.

6/ Existing structures or other landmarks that share functional relationships and connections with the future development.

7/ Existing structures or other features that have a negative impact on the area through poor siting, visual intrusion, deteriorated condition, noise, or some other factor.

8/ Vehicular or pedestrian circulation points of conflict and opportunity

9/ All utilities to serve the area or that will impact development.

10/ Required buffers, setbacks, or hazard zones as well as easements and right-of-ways that will restrict use of area.

11/ Important visual nodes such as points of entry or major intersections.

12/ Desirable visual impact to be enhanced and undesirable impacts to be screened.

13/ Significant vegetation, especially trees and shrubs.

(b) The opportunities and constraints map provides a graphic guide as to how the area should be developed and where development should and should not occur. Through this approach, information and observations are translated into action.

(c) The opportunities and constraints evaluation is used to verify the adequacy of the area for the proposed project. A key requirement for area verification is the determination that current user requirements obtained from the program analysis can be accommodated within the area defined. If the area is limited or confined so that it will not accommodate the project, the installation will provide a different site or the requirements must be revised.

(d) Limited or Confined Area. When areas do not provide adequate space for the requirements that have been defined, the planner will be required to closely coordinate with the user to determine how the facility can be planned to fit within the confines of the area. Some methods involve reducing the functional requirements, purchasing more land or further simplifying the design. The ADP site analysis should be used to determine the appropriateness of the limited or confined site for the proposed requirements and record that information in the opportunities and constraints analysis.

(3) Alternative Plan Development. The next step in the area development planning process is preparing a plan. Plan preparation begins with the development of alternative plans. Alternative plans are sketch plans that provide organization of the spatial requirements of the ADP. The alternative plans are used to study all possible siting arrangements for achieving an ideal site plan that includes the desired functional relationships and meets the established goals and objectives. Three different alternative plans are generally a minimum required for thorough analysis although more may be required to achieve the optimal configuration.

(a) Alternative plans employ spatial representations of areas drawn to scale to depict the facilities, activity areas, circulation, open space and other desired elements. Each alternative should include notations of potential problems and benefits, without formulating detailed responses to either. As each plan is developed, a record should be kept of the design strategies that were employed as a result of the design decision making process. This information will be used in developing an evaluation matrix for the final assessment of the alternatives. Information can be recorded on each plan or as a separate document.

(b) Alternative plans will include the following information:

- 1/ Delineation of area boundary.
- 2/ Vehicular circulation throughout the area.
- 3/ Delineation of existing and proposed development sites.
- 4/ Site access points, including service access.
- 5/ Pedestrian access and potential linkage.
- 6/ Significant features and proposed landmarks.

(c) The Army provides standard designs for many facilities which may include a site plan to be used where applicable. The standard designs serve as guides only and do not refer to any individual area.

(d) The preparation and evaluation of three alternative plans for the installation community center are provided below as examples of the alternative plan preparation and review procedure process discussed.

1/ Alternative 1 (figure 2-11) includes the following:

a/ Spatial requirements for parking have been provided for all new facilities located within the area.

b/ The guest housing facility has been located near the entrance to the installation to accommodate visitors easily.

c/ The environmentally sensitive area located at the north end of the area has been preserved and used for passive recreation. Pedestrian access is provided from the commercial center to encourage environmental interaction.

d/ Vehicular circulation has been modified. Existing roadways have been preserved wherever feasible. A traffic circle has been developed at the center of the area. This element will serve as a hub around which traffic will flow without having to stop. A landmark or monument is proposed for the center of the traffic circle to serve as a visual focal point. This design facilitates the addition of a fifth roadway to provide access to the bank and guest housing facilities. The entrance roadway has been extended to provide through access to the southeast area of the installation.

e/ Ample open space has been preserved, especially in response to the traffic circle. The proposed open space serves as a visual buffer between elements and to emphasize the central landmark. A large parcel of land at the south end of the area has been preserved for future development.

f/ The credit union facility has been located at the southern end of the area at the intersection of the entrance road and the south connector road. This location will

facilitate ease of use and is convenient to users who do not wish to enter the community center.

g/ The bank facility is located in the northwest corner near the entrance to the installation to provide convenient access from on-base and off-base.

h/ Service vehicles must circulate through the main traffic circle to reach the service entrances of the commercial center site. This may create some traffic congestion through the hub, but results in the preservation of the environmentally sensitive area.

i/ Pedestrian access has been provided throughout the area. In areas of high use, pedestrian access has been separated from vehicular access. Separate pedestrian access has been provided between the commercial center and the bank and between the commercial center and the recreation area as well as within the commercial center.

j/ The commissary facility has been sited adjacent to the PX at the north end of the site in an effort to consolidate the facilities and resources.

2/ Alternative 2 (figure 2-12) includes the following:

a/ Spatial requirements for parking has been provided for all new facilities located within the area.

b/ The guest housing facility has been located near the entrance to the installation to accommodate visitors easily.

c/ The environmentally sensitive area located at the north end of the area has been preserved and used for passive recreation. Pedestrian access is provided from the commercial center and from the guest housing facility to encourage environmental interaction.

d/ Vehicular circulation has been modified. Existing roadways have been preserved wherever feasible. Traffic circles have been created at the two busiest intersections. A landmark has been proposed for the center of each of these intersections. In addition, a north-south connecting roadway has been created to improve access to the commercial center. The entrance roadway has been extended to provide through access to the southeast area of the installation.

e/ Open space has been preserved at the entrance to the installation and along the entrance roadway. These two spaces provide a buffer for the guest housing facility. A large parcel centrally located within the area has been preserved for future development.

f/ The credit union facility has been located at the southeastern corner of the area. This location will facilitate ease of use and is convenient to users who do not wish to enter the community center. The credit union has been located adjacent to the bank facility to consolidate land uses and improve vehicular circulation.

g/ The bank facility is located at the southwest corner of the area. This location will facilitate ease of use and is convenient to users who do not wish to enter the

community center. The credit union has been located adjacent to the bank facility to consolidate land uses and improve vehicular circulation.

h/ Service vehicles must circulate through the two traffic circles to reach the service entrances of the commercial center site. This may create some traffic congestion through the hub. However, because access is directed through the hub, the environmentally sensitive area has been left undisturbed.

i/ Pedestrian access has been provided throughout the area. In areas of high use, pedestrian access has been separated from vehicular access. Separate pedestrian access has been provided between the commercial center and the recreation area as well as within the commercial center and between the guest housing facility and the recreation area.

j/ The commissary facility has been sited adjacent to the PX at the north end of the site in an effort to consolidate the facilities and resources.

3/ Alternative 3 (figure 2-13) combines several aspects of Alternatives 1 and 2 and provides a new solution for one of the site concerns. This plan provides the following:

a/ Spatial requirements for parking have been provided for all new facilities located within the area.

b/ The guest housing facility has been located near the south end of the area. This location will accommodate visitors easily but will reduce vehicular impacts at the entrance to the facility. Access to the rest of the installation is improved with this location.

c/ The majority of the environmentally sensitive area located at the north end of the area has been preserved and used for passive recreation. Some of the edge of the area has been disturbed with the introduction of a service road. Pedestrian access is provided from the commercial center to encourage environmental interaction.

e/ Vehicular circulation has been modified. Existing roadways have been preserved wherever feasible. The east-west roadway has been realigned and the entrance roadway has been extended to provide through access to the southeast area of the installation. Two tertiary roadways have been created to improve access to the commercial center and to the bank and guest housing facility.

f/ A large parcel of land has been preserved at the entrance to the installation for future development. Another future development site has been created to the south of the entrance adjacent to the entrance road.

g/ The credit union facility has been located at the far east end of the area. This location will facilitate ease of access for users within the commercial center.

h/ The bank facility is located in the center of the area. This location provides ease of access with the commercial center, the guest housing facility, and the consolidated club facility.

i/ Service vehicle circulation has been separated from the main circulation roadways. From the entrance, service vehicles are directed to the perimeter where commercial center service access is located. To facilitate this circulation pattern, a portion of the environmentally sensitive area is impacted.

j/ Pedestrian access has been provided throughout the area. In areas of high use, pedestrian access has been separated from vehicular access. Separate pedestrian access has been provided between the commercial center and the recreation area.

k/ The commissary facility has been sited adjacent to the PX at the north end of the site to consolidate the facilities and resources.

(4) Alternative Plan Evaluation. Upon completion of the alternative plan preparation, the alternatives will be evaluated and a preferred plan selected. The evaluation process requires that an evaluation matrix be prepared that lists all of the pros and cons that were defined during preparation of the alternative plans. The evaluation matrix for the installation community center area plan is presented in figure 2-14. The process includes comparison of conflicting project demands such as site constraints, ideal solutions, costs, and future expansion needs. The preferred plan will be the one that best addresses the preservation of the environmental attributes of the site, provides the required functional and spatial relationships, and meets the project goals and objectives outlined at the outset of the ADP process. The preferred plan may be one of the selected alternatives or a composite of the most desirable aspects of several or all of the alternatives.

(a) The plans and their design strategies should be reviewed by the personnel listed below to assess the alternatives and review the preferred plan recommendations. The review should include evaluation of the planning matrix, the assets and liabilities of each alternative plan and the recommended preferred alternative.

1/ Design Team.

2/ Customer.

3/ User.

(b) The review personnel should reach a consensus for selecting the recommended preferred plan or an alternative solution to the preferred plan. If an alternative solution is selected, the review personnel should prepare a definitive analysis of the assets and liabilities of the alternative solution that led to selection over the preferred alternative. The preferred plan must be presented to and approved by the Installation Commander and the Installation Planning Board as the final step in the selection process.

(5) Final Area Development Plan. The final area development plan is prepared from the preferred alternative plan through the following process:

(a) Preliminary ADP. The preliminary plan will be prepared as a sketch plan that includes all of the existing and proposed facilities and other activities that will be located within the land areas defined in the preferred plan. These include, but are not limited to

proposed roadways, buildings, driveways, parking, open space, and future development areas (figure 2-15). The preliminary ADP will be presented to the review personnel for review and comment before the Final Plan is prepared. Once the preliminary plan is approved, the Final Plan will be prepared.

(b) Final ADP. Development of the final plan from the preliminary ADP sketch will include a location plan, a graphic illustration of the proposed development, and a written report defining the process and the various elements of the plan.

1/ Location Plan. The location plan can be included as an inset on the Final Plan sheet or as a separate drawing. The purpose of the location plan is to illustrate the location of the development area in relation to the surrounding activities (figure 2-16). Roadways, driveways, pedestrian walkways, utilities, drainage ways and other impacts outside the area should be included. The location plan should be prepared on a standard sheet, to scale, with a north arrow. It may be prepared in color or in black and white.

2/ Final ADP. The final plan graphic should be drawn on a standard sheet, to scale with a north arrow (figure 2-17). Typically, the following elements are included as a minimum on the Final Plan:

a/ Building envelopes drawn to reflect the required square meters (square footage), general desired configuration and desired orientation. The final footprint will be determined in the final Site Plan.

b/ Building setbacks including roadway, property line, environmental, archeological, and safety setbacks.

c/ Existing and proposed roadways and driveways shown at the desired widths and turning radii. Parking lots to accurately portray the spaces and total number of vehicles to be accommodated.

d/ Existing and proposed pedestrian walkways drawn to scale to illustrate width and location.

e/ Areas for plazas or outdoor displays should be identified through graphic illustration or notation.

f/ Areas with special paving or street furnishings should be identified through graphic illustration or notation.

g/ Major landscape elements, such as existing and proposed trees, shrub massing, displays of flowering plants, and significant trees or areas of trees to be preserved.

h/ Large scale open space elements such as athletic fields and parade grounds.

i/ Service areas including trash dumpster locations with screening by walls, fences and or shrubs and trees.

j/ Areas for future expansion whether planned or potential.

k/ Major utility corridors and routings for gas, water, sewer, storm drain lines, telephone, electric, steam, etc.

3/ The Area Development Plan Report. A report to accompany the final plan should include a brief narrative of the Area Development Plan process to provide an overview of the analysis and results. The entire process should be defined including all of the steps taken in the process from the statement of the goals and objectives through selection of the Preferred Alternative Plan and final plan. The report should include copies of all matrices, tables, plans, and sketches used in the process. The narrative should provide a full explanation of the final plan including the following:

a/ The effect of the plan on the Real Property Master Plan.

b/ Proposed facility projects.

c/ Recommended transportation improvements.

d/ Recommended utilities systems upgrades and infrastructure improvements to meet facilities requirements.

e/ Architectural design recommendations and guidelines.

f/ Landscape design recommendations and guidelines.

g/ Site design recommendations and guidelines.

4/ The Area Development Plan Sketches. The area development plan is an inherently flexible document that can be tailored to specific needs. Once the final plan is complete, a variety of more detailed sketches may be included in the ADP report to focus on particular problems or to illustrate the design thought process. These sketches may include:

a/ Building massing, view enhancement/protection strategies.

b/ Proposed roadway and driveway cross sections used to develop the plan.

c/ Landscape planting design and plant material details.

d/ Other design detailing such as material and color palettes for buildings, pavements, site furnishings, etc.

e/ Signage, lighting or other street furniture recommendations.

c. Implementation. The Area Development Plan process relies on a variety of mechanisms for implementation. The plan is directly linked to AR 415-15 which identifies project development procedures to prioritize projects for funding and execution.

(1) Prepare a Schedule and Phasing Plan. The most expedient approach to developing a schedule for implementation actions is to list each project, beginning with the first, and all the actions required for successful completion. The construction of a new military facility requires that an existing building be demolished before construction can begin. The occupants of the existing building would require relocation either temporarily or permanently, making their move the first necessary action associated with the project. The action list for this set of circumstances might read as follows:

- (a) Move Organization A out of Building X into new or interim headquarters.
- (b) Demolish Building.
- (c) Construct Building Y on former site of Building X.
- (d) Move Organization B from Building Z to Building Y.

(e) Demolish Building Z (or move Organization C into Building Z). The demolition of Building C or the movement of Organization C may then be the beginning of another project cycle.

(2) Determine Funding Priority. All proposed projects, including facilities, parking, circulation and landscape design should be classified by priority and funding according to the three classifications listed below. Projects in the intermediate and independent categories can proceed at the discretion of the Installation Commander and the availability of funds. Interdependent projects must be accomplished in the proper sequence.

- (a) Immediate. Projects that are funded and proceeding.
- (b) Independent. Projects that may be completed in any order because they are not dependent upon completion of another project to proceed.
- (c) Interdependent. Projects that are dependent upon the completion of another project before they can be implemented.

(3) Scheduling. Once all the necessary actions have been identified, dates can be assigned to each action or group of actions. This then becomes the schedule that the installation uses to track the progress of the plan and insure its orderly implementation. Figure 2-18 illustrates a typical phasing plan. The implementation phase includes the preparation of a requirements and management plan and the long range plan.

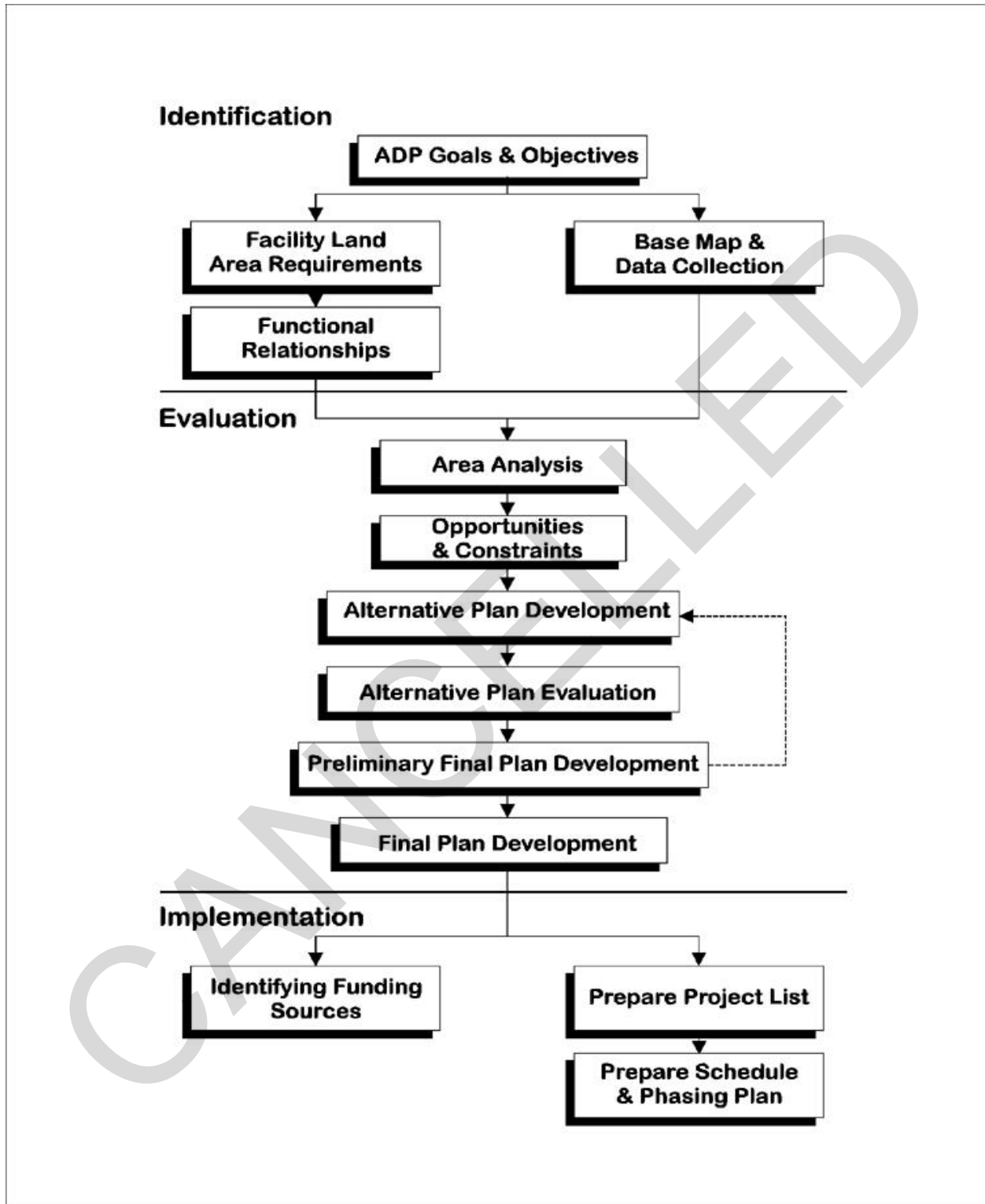

Figure 2-1. The area development plan process

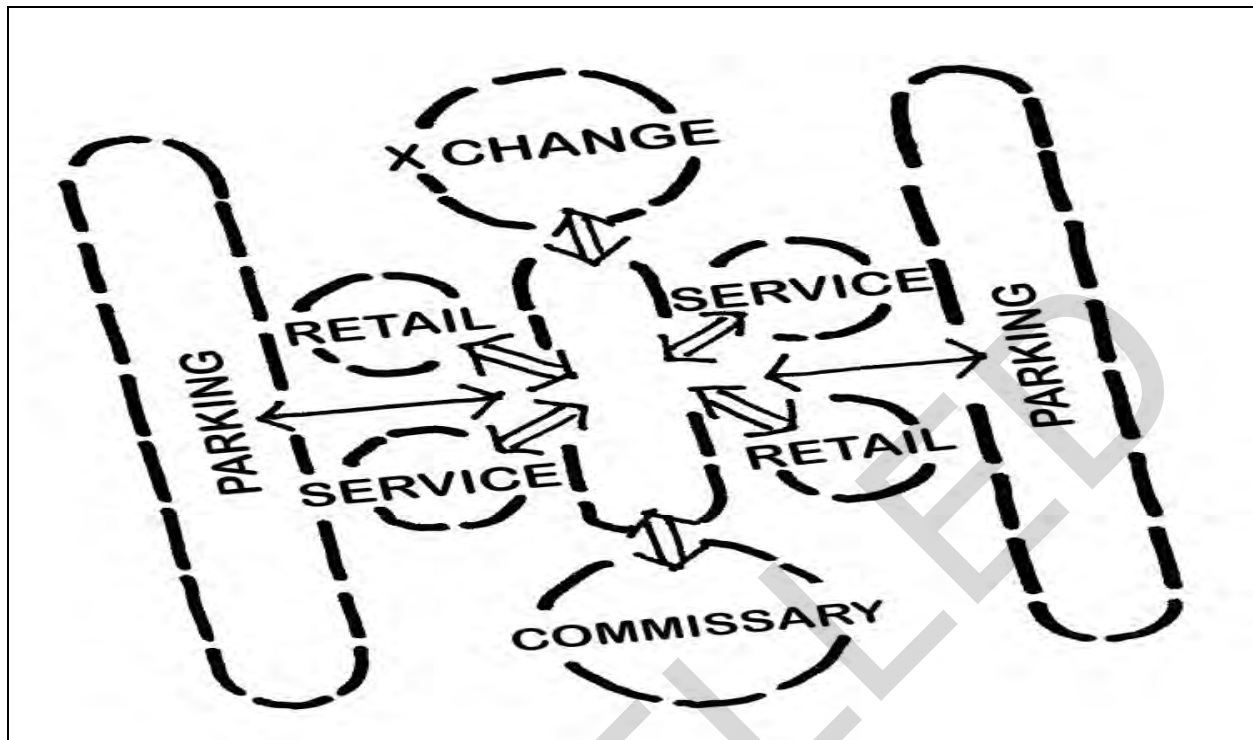

Figure 2-2. Functional relationships bubble diagram

Legend	Commissary	Exchange	Post Office	Indoor Rec. Facilities	Library	Bank Credit Union	Chapel
● Collocation Desired							
◐ Compatible	●	◐	◐	◐	◐	◐	◐
○ Incompatible	○	○	◐	◐	◐	◐	○
Commissary							
Exchange							
Post Office							
Indoor Rec. Facilities							
Library							
Bank Credit Union							
Chapel							

Figure 2-3. Functional relationships matrix

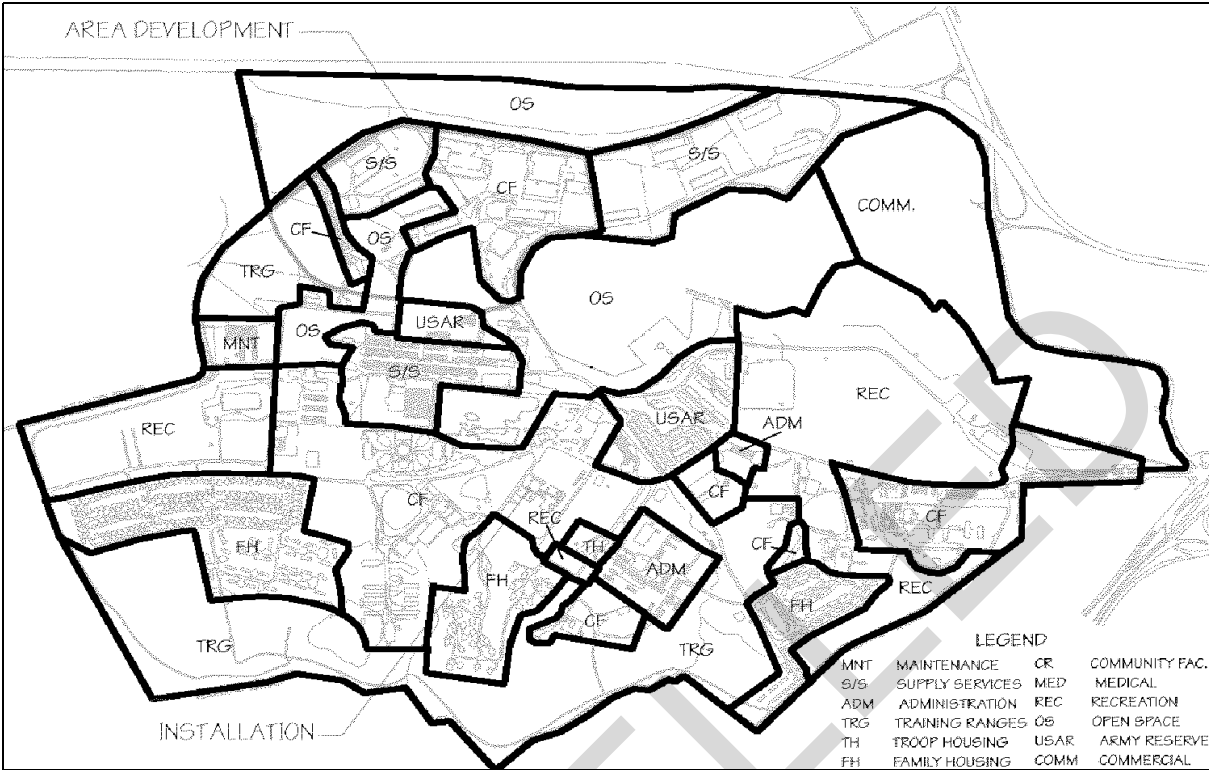

Figure 2-4. Area land use

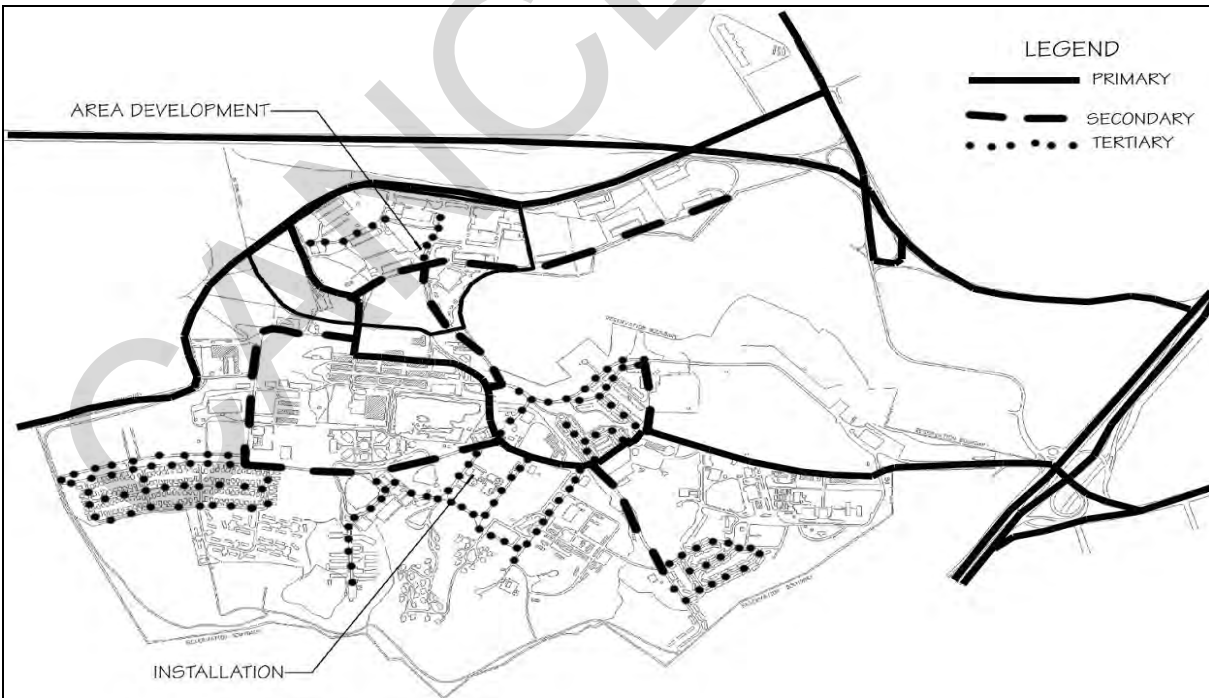

Figure 2-5. Area transportation

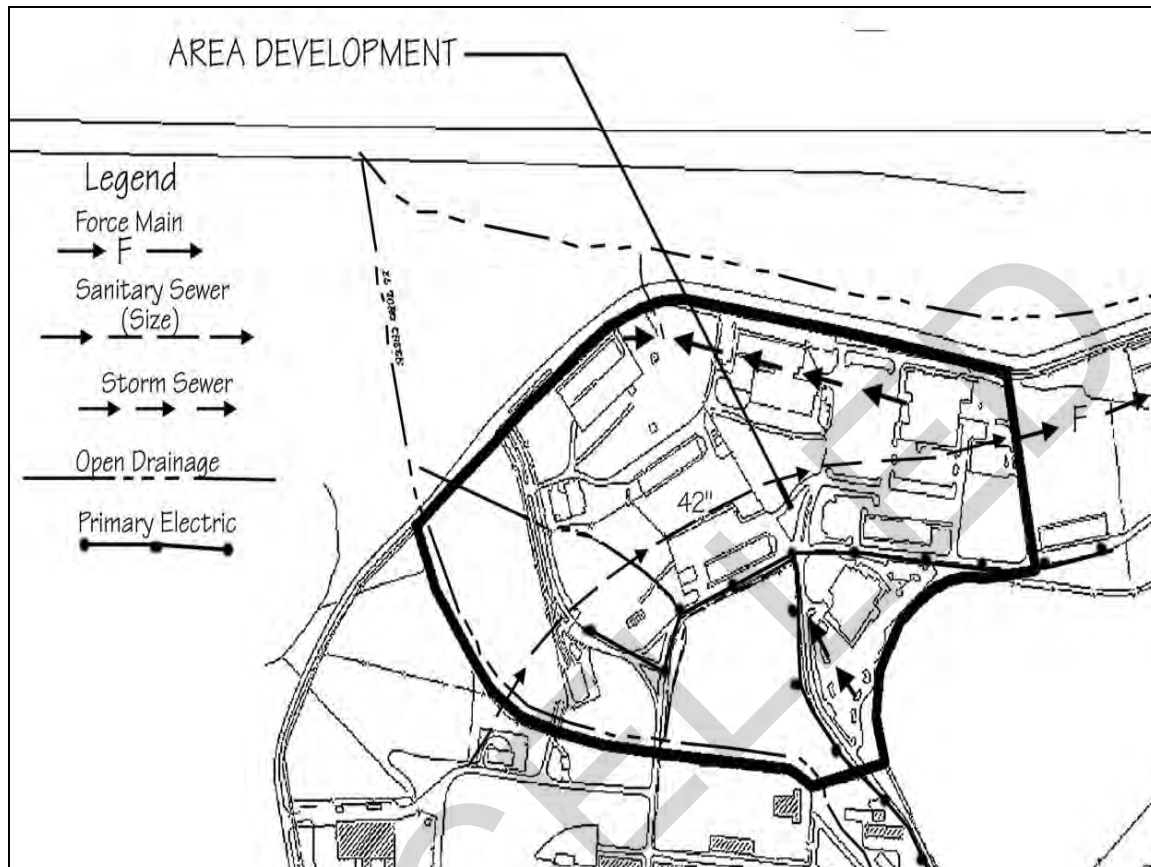

Figure 2-6. Area utility supply lines

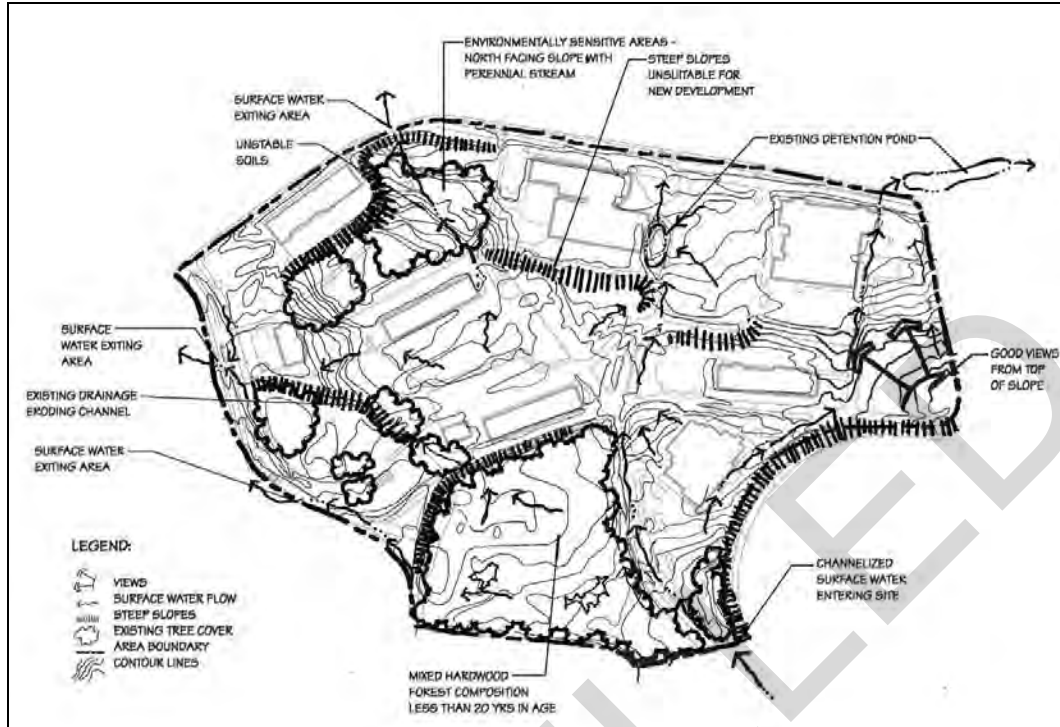

Figure 2-7. Analysis of natural environment

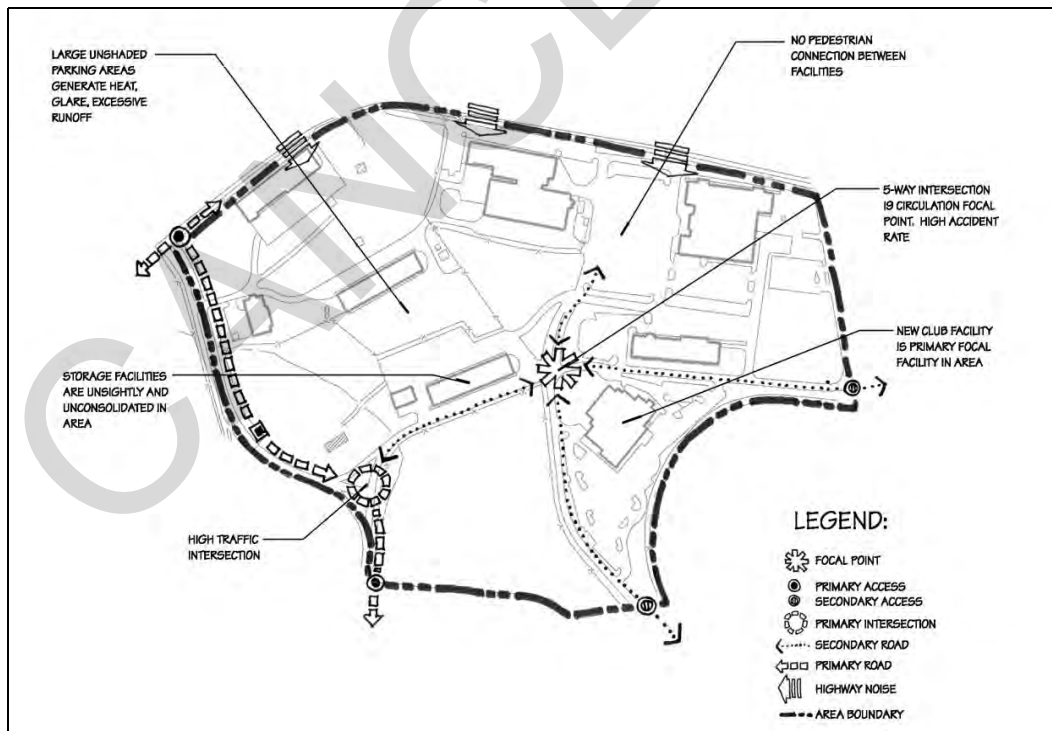

Figure 2-8. Analysis of built environment

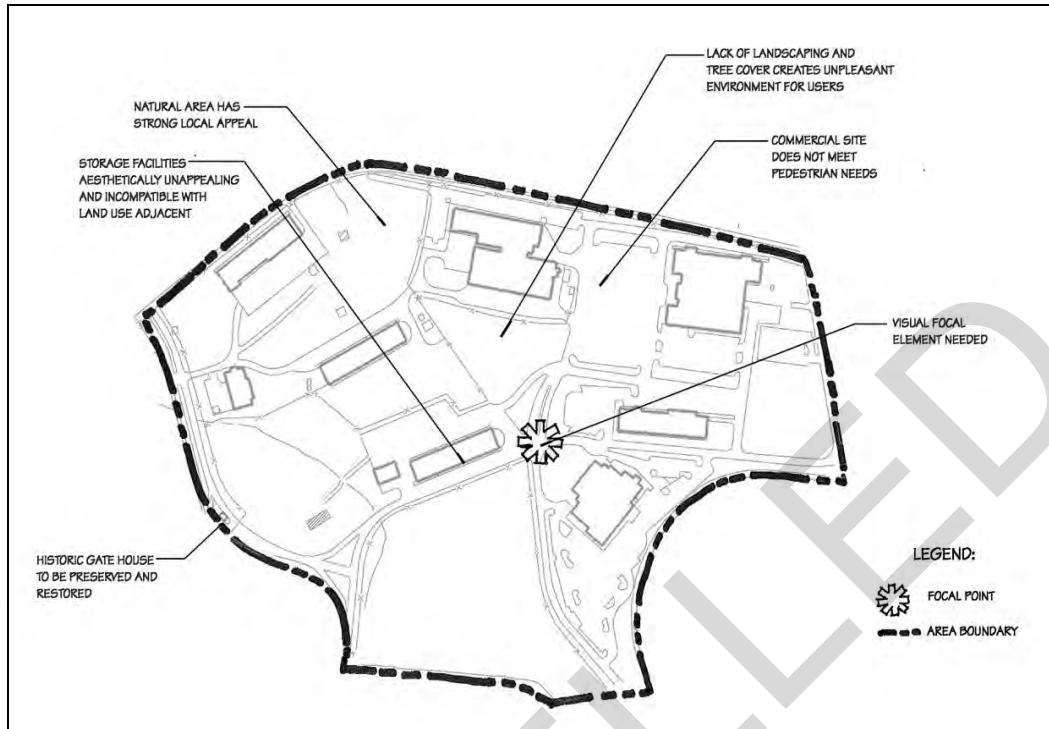

Figure 2-9. Analysis of socio-cultural environment

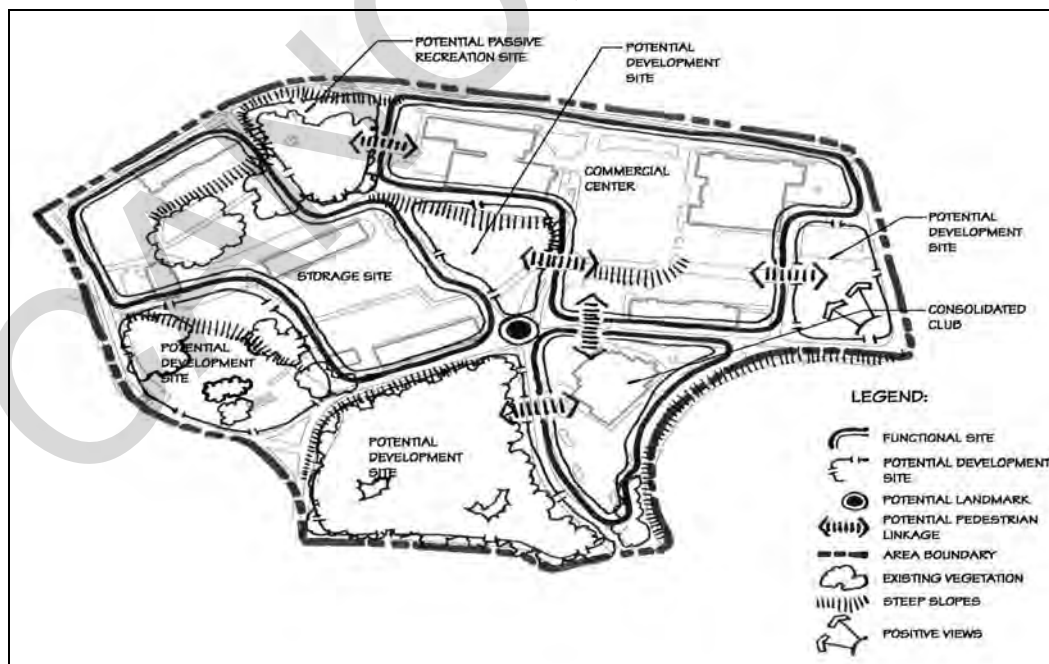

Figure 2-10. Opportunities and constraints

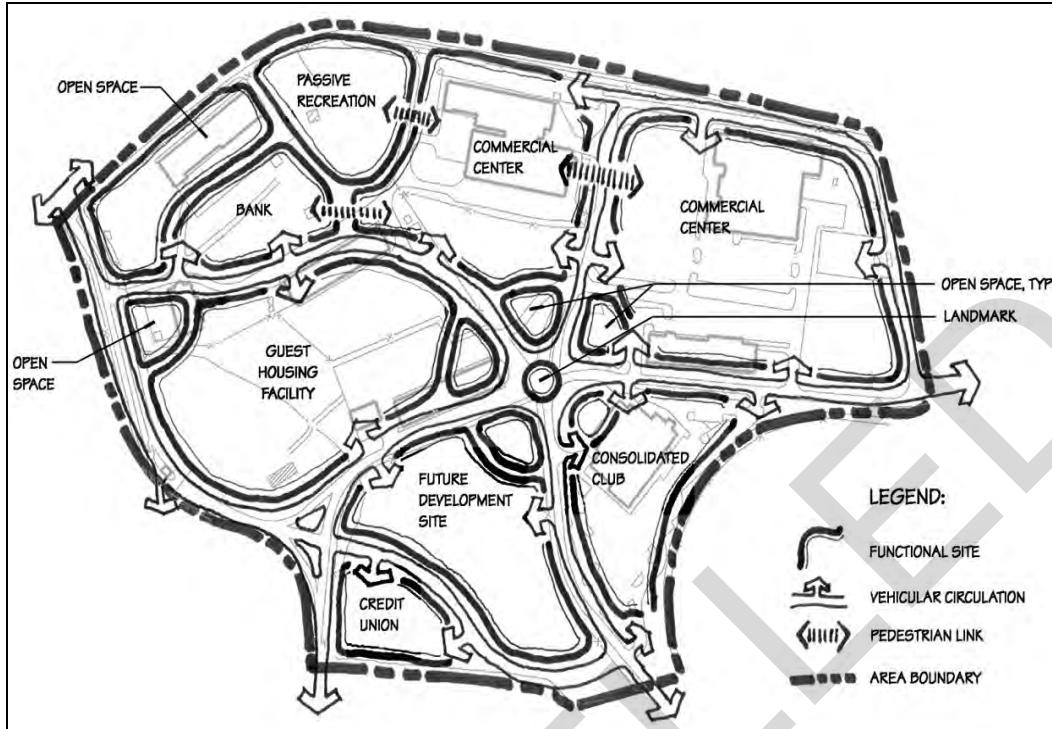

Figure 2-11. Alternative 1 sketch plan

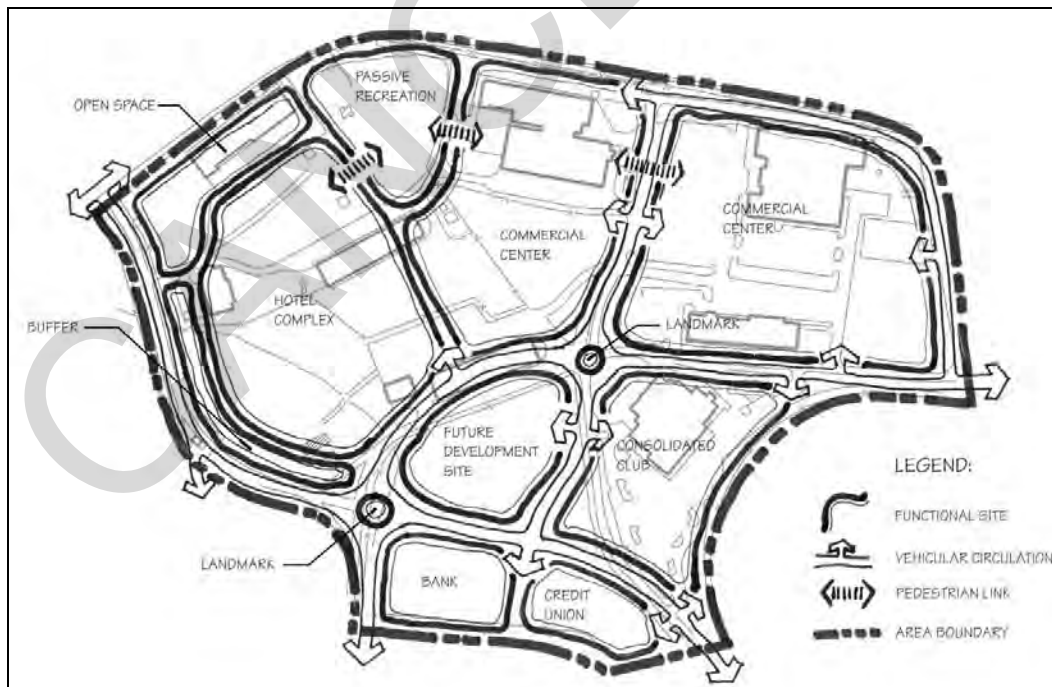

Figure 2-12. Alternative 2 sketch plan

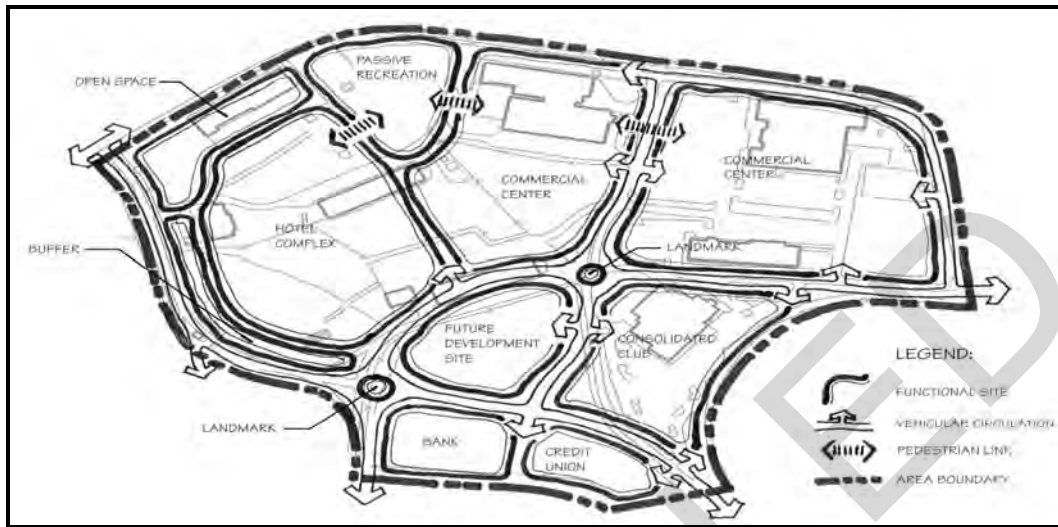

Figure 2-13. Alternative 3 sketch plan

	Alternative 1	Alternative 2	Alternative 3
Provide additional parking for new facilities	2	2	1
Siting of new guest housing facility	2	4	1
Protection of all Environmentally Sensitive Areas	1	1	2
Modify intersection to lower accident frequency	4	1	2
Provide open space for future development	1	1	1
Siting of credit union facility	2	3	1
Siting of bank facility	5	2	1
Provide improved access for service vehicles	4	3	1
Separate pedestrian and vehicular circulation where feasible	1	1	3
Siting of commissary facility	1	1	1
TOTALS	23	19	14
(1=Good, 5=Poor)			

Figure 2-14. Evaluation matrix

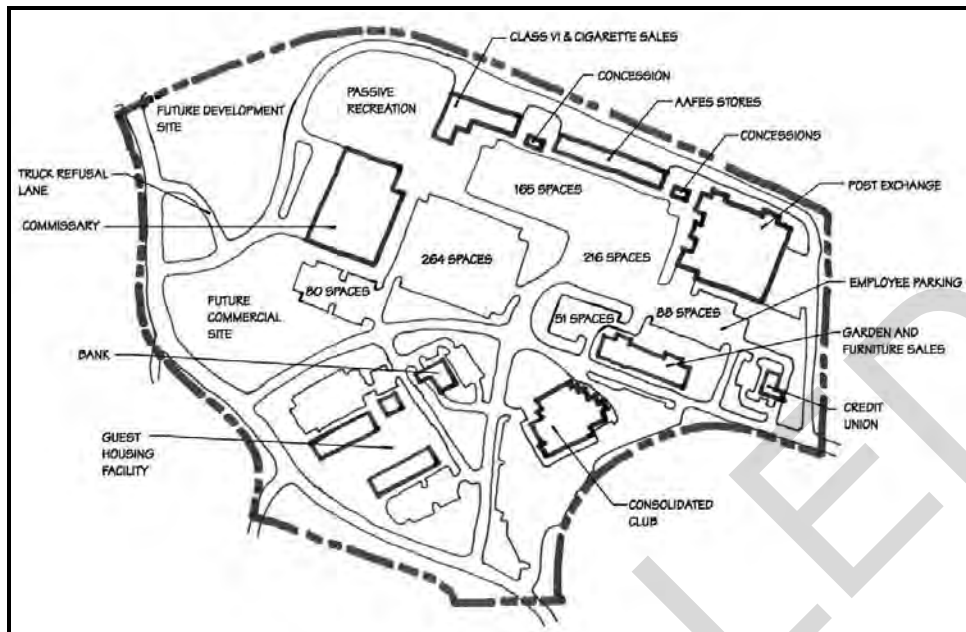

Figure 2-15. Preliminary area development plan

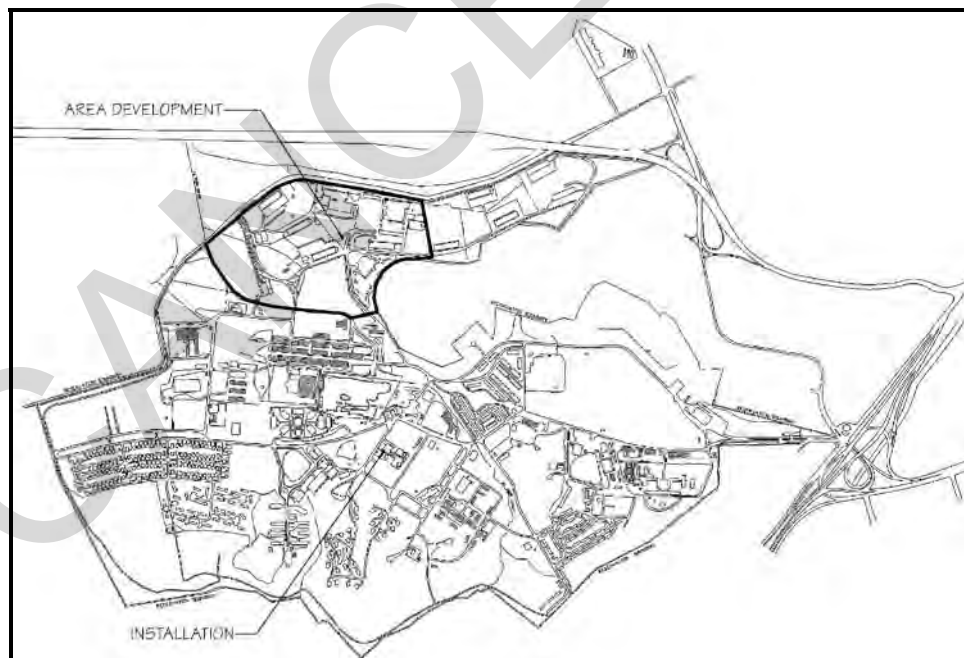

Figure 2-16. Location map

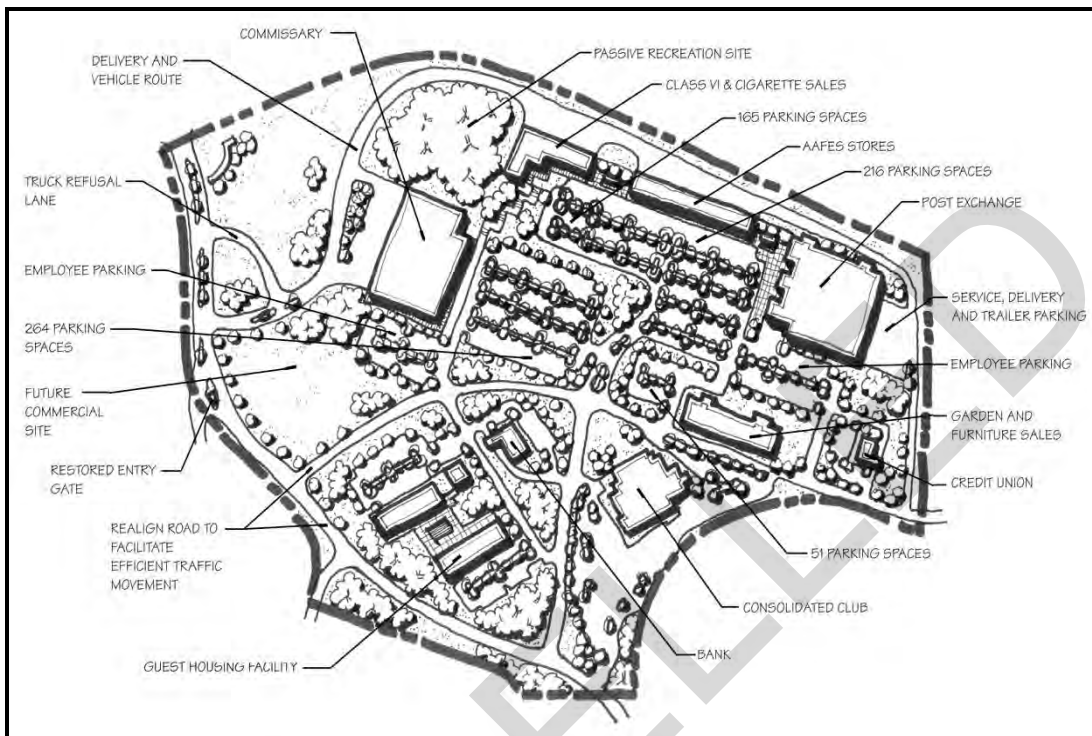

Figure 2-17. Final area development plan

CANCELLED

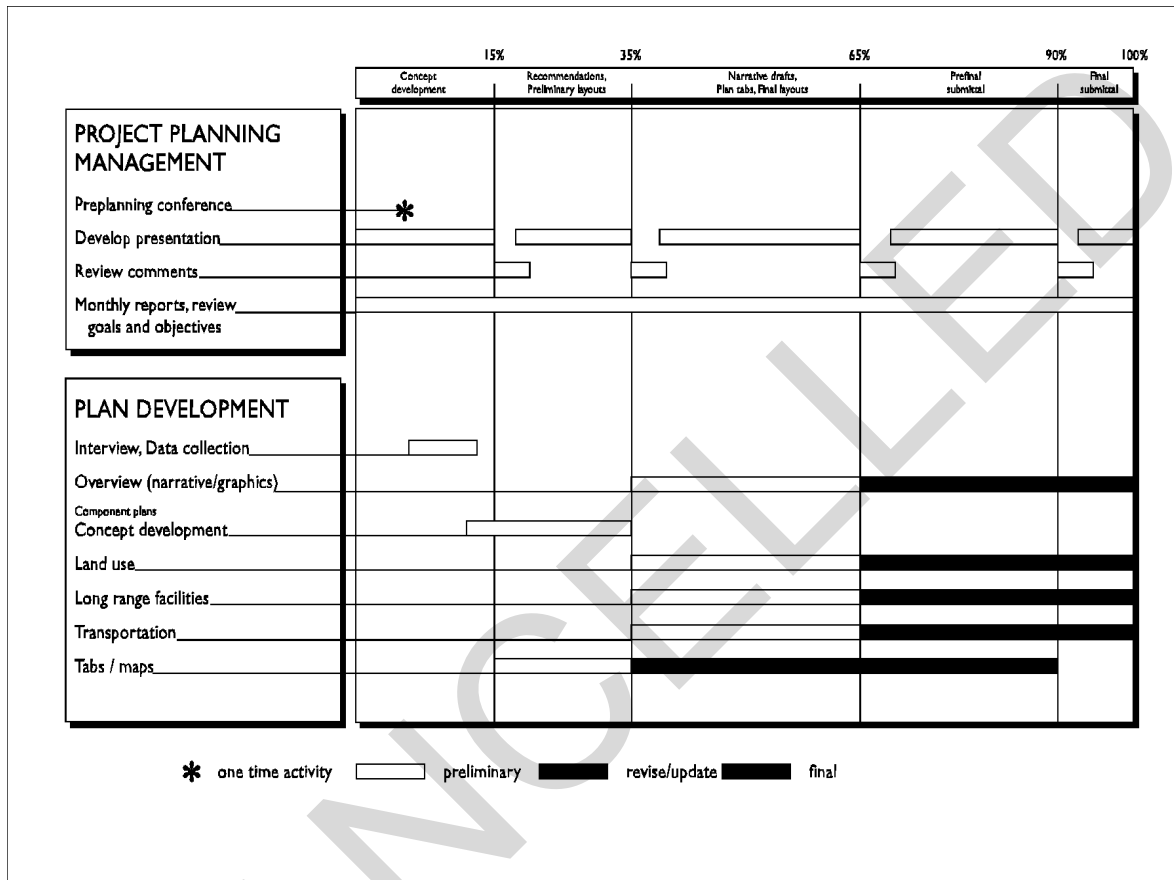

Figure 2-18. Phasing plan

CHAPTER 3

THE SITE PLAN

3-1. GENERAL. This chapter provides guidance for site planning procedures and for preparing a Site Plan.

3-2. RELATIONSHIP TO THE AREA DEVELOPMENT PLAN. An Area Development Plan may have been prepared which should provide a sketch of the facilities proposed on site. If a specific site was not part of an ADP and no conceptual plan has been prepared, review the ADP process defined in Chapter 2 of this instruction, and develop a Concept Plan for the site. Once the concept plan has been prepared and adopted by installation command, the Site Plan can be prepared.

3-3. THE SITE PLANNING PROCESS. The site planning process includes all of the steps outlined for the ADP process. The difference is in the greater detail that is required for the site plan. The site planning process is designed to occur sequentially, from beginning to end, resulting in the final Site Plan which is a detailed plan that will be used to develop construction drawings. The process involves standard land use planning practices in three major phases: Identification, Evaluation, and Implementation. The process to be followed is described in this section. For this instruction, a Site Plan for an installation Guest Housing Facility will be developed to illustrate the sequence of steps included in the process.

a. Identification. The identification phase includes setting goals and objectives, defining detailed facility and spatial requirements, defining functional relationships, and collecting base data and maps.

(1) Goals and Objectives. The goals and objectives of the site are based upon the goals and objectives of the user mission and installation development. Therefore, preparing goals and objectives requires an in-depth review of the user's mission and definition of how the proposed project is intended to accomplish or support the mission. The goals and objectives become guidelines for the planning process. The goals are more general in nature, while the objectives define specific actions that will achieve the goals.

(a) Goal: Provide for a convenient, well planned guest housing facility.

1/ Objective 1: Provide logical arrangement of Army guest buildings to provide for all rooms to be located within close proximity to office and central storage facility.

2/ Objective 2: Provide central office/check in at main vehicular entry point.

3/ Objective 3. Provide centralized swimming pool and outdoor gathering area.

(b) Goal: Provide adequate parking

1/ Objective 1: Provide 1 ½ parking spaces per guest room, 1 parking space per employee, and 5 parking spaces for the office/check in.

2/ Objective 2: Locate all guest spaces within close proximity to guest rooms.

3/ Objective 3: Provide vehicular service area for laundry and supply vehicles.

(2) Facility and Land Area Requirements. Once the goals and objectives have been reviewed and approved, the actual requirements and spatial needs for the site should also be reviewed. Accurate project requirements are fundamental to organizing and locating project elements on site. Failure to anticipate program and spatial needs can create problems with available land area, compatibility of functions and available utilities. The land area or spatial requirements are determined by the functional requirements of the user. The land area requirements include the building foot print and the other functions that are required to serve the facility, such as vehicular access, service area, staff and visitor parking, pedestrian access and open space.

(3) Functional Relationships. The functional relationships of the proposed facilities should be reviewed and organized in greater detail within the site. This process consists of analyzing the interactions between facilities and activities to determine whether they should be close together or separated in order to function in a compatible manner. Chapter 2, figures 2-2 and 2-3, illustrate typical functional relationships diagrams. Where functional relationships have not been determined, the methodology outlined in Functional Relationships should be followed.

(4) Base Map and Data Collection. The inventory of the site data will occur simultaneously with the definition of project requirements and their functional relationships. This inventory includes the collection of base maps and data about the environmental and manmade characteristics of the site and its environs. Base maps will have been prepared for the area development plan and/or concept plan for the site. These maps may not include the detail required for the preparation of a Site Plan, however, they will serve as useful reference guides during site plan preparation. The base maps and other data that will be required for the Site Plan are as follows:

(a) Base Maps. The base maps used for preparing a Site Plan will typically be prepared at a ratio of no greater than 1:1000. This scale will vary depending upon the size of the site. The base maps that will be collected or prepared include:

1/ Site Base Map. This map should include the following data about the site:

a/ Topographic survey at one meter intervals.

b/ Surveyed location of all existing structures such as paving, fences, and utilities.

2/ Tree Survey Map. A tree survey should be performed to record all trees with a diameter at breast height (DBH) of 10.0 centimeters (4 inches) or greater with their location, common and botanical name, size and condition.

3/ Location Map. A location map is included to show the location of the site in the vicinity in which it is located. Typically, this map includes the primary facilities, major roadways, and other characteristics defining the immediate vicinity of the site.

4/ Utilities Map. Existing and proposed utility locations are shown in the vicinity of the site by size and type.

5/ Transportation Map. Existing and proposed area transportation is shown with existing and proposed carrying capacity of roadways, hierarchy of roads, and any proposed improvements.

6/ Other Maps. Aerial photographs, flood maps, Soil Conservation Service soil surveys, and USGS topographic surveys can provide important data about the area.

(b) Data Collection. Data to be collected falls into three broad categories corresponding to the three environments in which people live and work: The natural environment, the built environment, and the socio-cultural environment. If an ADP and/or concept plan has been prepared, a great deal of data collection and synthesis has already been completed and should be available for the preparation of the Site Plan. The data required for the Site Plan must be site specific and typically in greater detail than that collected and used for area development plans. Site specific data includes the following:

1/ Background data such as the Real Property Master Plan, the Installation Design Guide, installation reports, area development plans and/or concept plans and user information.

2/ Architectural and Engineering Instructions (AEI), Design Criteria, provide site planning information for all facility types. This information includes requirements for non-organizational vehicle (POV) and visitor parking, energy conservation model, utility and fire protection clearances.

3/ Soil borings to determine the type and capacity of the soil to support the proposed facilities.

4/ Geologic and hydrologic analysis using soil borings.

5/ Existing ecological features of the site.

6/ Significant climatic conditions such as wind, sun, or other precipitation.

7/ Significant views to be enhanced or obscured.

8/ Significant architectural or historical features or other preservation requirements.

9/ Proposed improvements and other changes that will impact the site.

(5) Site Visit. A site visit is essential to the preparation of a site analysis. It provides a visual assessment of features such as architectural character, significant views, landscape character, and prominent land features should be inspected and recorded. The AEI provides guidance for the procedures of the visual survey. The site visit provides the opportunity to:

(a) Review and verify existing information. This can be done visually and with photography and sketches.

(b) Evaluate the compatibility of existing on- and off-site conditions.

(c) Discover previously unknown or unrecorded conditions and factors.

(d) Evaluate the design qualities and visual qualities of the site.

b. Evaluation. The evaluation phase includes analyzing the data collected and preparing site opportunities and constraints map.

(1) Site Analysis. After the detailed base maps and data for the site are collected, the data should be recorded on the maps to define in detail the physical and environmental characteristics of the site and its immediate environment. Site analysis at this stage of site planning is a far more detailed analysis of the specific site. Site analysis includes preparing a detailed drawing. This drawing should include all of the detailed information defined in data collection. The map will be an accurate depiction of the site and its characteristics including:

(a) Off-site conditions. Information concerning the surrounding environment. The following information must be obtained to perform an accurate site analysis.

1/ Surrounding Land Use. Surrounding land use should be recorded and the appropriate land use category verified.

2/ Transportation. A Site Traffic Impact Analysis for the area should be prepared. Survey the adjacent roadways showing existing lanes, curb, drainage, and curb cuts. Existing and proposed hierarchy of roadways, carrying capacities, design vehicle, and current traffic counts for a.m. and p.m. peak hour traffic. Future plans should include all proposed new roadways or roadway improvements that would impact the site.

3/ Utilities. Surveyed location of all utilities in the immediate vicinity to the site including the size of the lines, capacities of generation, current and projected demand, and proposed expansion. The utilities to be included are:

a/ Water system with locations of fire hydrants.

b/ Sanitary sewer system.

- c/ Storm drainage system and drainage basin with invert elevations.
- d/ Electrical, gas, and steam systems.
- e/ Telephone system.
- f/ Other types of communication systems or specialized utility systems.

4/ Environmental conditions and hazard (AR 200-2 and AR 415-15 provide further guidance on assessing environmental conditions):

direction of flow.

- a/ Storm drainage patterns indicating watershed boundaries and the

- b/ Storm water management areas.

- c/ Flood plains.

- d/ Wetlands.

- e/ Wildlife habitats

- f/ Buried Tanks

5/ Historic, cultural and/or archeological resources. Any regulations governing activity near them should be identified.

6/ Safety Hazards. All requirements and distances necessary for safety such as fire codes, flood control, airfield and helipad clear zones, and explosives safety should be identified.

7/ Physical security. Coordinate the physical security requirements with the Physical Security Plan of the installation. Existing or potential threat, high probable risk targets, and current vulnerabilities to deter attack should be determined by consulting with the Provost Marshal.

8/ Sources of Air, Noise and Light Pollution. Any immediate sources of air, noise, and light pollution should be identified and their impact upon the site evaluated.

9/ Visual Enclosure. Desirable or undesirable views from the site should be recorded.

(b) On-site data. All factors within the site which may effect development should be recorded and analyzed as part of the Natural Environment Analysis, the Built Environment Analysis, or the Socio-cultural Environment Analysis. Figure 3-1 illustrates a Natural Environment Analysis for the facility development site within the guest housing facility of the Community Center ADP example from Chapter 2. The following elements should be examined to evaluate potential impacts and connections within the site development.

- 1/ Topography survey at one-quarter (.25) meter interval contours.
- 2/ Surveyed location of all existing structures, paved and nonpaved vehicular and pedestrian areas, fences, and utilities.
- 3/ Surveyed location of all abutting vehicular and pedestrian areas.
- 4/ Accurate soils identification for all areas of the site.
- 5/ Surveyed Location of wetlands, drainage ways, lakes, ponds, etc.
- 6/ Mean high tide and areas prone to flooding.
- 7/ Surveyed location of all utilities in the immediate vicinity to the site including the size of the lines, capacities of generation or treatment plants, and current and projected utilization, and proposed expansion. The utilities to be included are:
 - a/ Water system with locations of fire hydrants.
 - b/ Sanitary sewer system.
 - c/ Storm drainage system with invert elevations.
 - d/ Electrical gas system.
 - e/ Telephone system.
 - f/ Other types of communication systems.
- 8/ Surveyed location, common and botanical name, size and condition of all trees with a diameter at breast height (DBH) of 10.0 centimeters (4 inches) or greater.
- 9/ Surveyed Location of buried tanks, IRP's and other hazards
- 10/ Surveyed location of wildlife habitats (especially for threatened and endangered species)
- 11/ Significant architectural or historical features or other preservation requirements
- 12/ Significant climatic conditions including:
 - a/ Average monthly temperature range
 - b/ Quantity and frequency of precipitation
 - c/ Midwinter and midsummer sunrise and sunset orientation and angle

d/ Prevailing wind direction throughout the year

13/ Significant views to be enhanced or obscured

14/ Detailed list of safety hazard requirements and distances including:

a/ Fire codes

b/ Barrier-Free Design

c/ Radon

d/ Flood control

e/ Airfield and helicopter clear zones

f/ Explosives safety zones

15/ Visual Survey. Provide an evaluation of the visual character of the site. This may include view boundaries, special visual features, vegetative character, microclimate conditions, or sensory information.

16/ Other proposed improvements and changes that will impact the site.

(2) Opportunities and Constraints. The second step in evaluating the development potential of the site is the preparation of a site opportunities and constraints map. This map is a graphic representation of all of the positive and negative site characteristics analyzed in the site analysis that will influence the location of the elements of the Site Plan. For preparing the site plan, the opportunities and constraints should include detailed analysis of slopes, drainage, trees to be preserved, views to be screened or enhanced, width of roadways and walkways, existing building footprints, size and locations of other on-site and off-site natural or manmade features that will impact the planning of the site. The opportunities and constraints as defined for the site plan should provide the opportunity to "fine tune" the previous map (figure 3-2).

Limited or Confined Site. When a site does not provide adequate space for the requirements that have been defined, the planner will be required to closely coordinate with the user to determine how the facility can be planned to fit within the confines of the site. Some methods may involve reducing the functional requirements, purchasing more land or further simplifying the design. The site analysis should be utilized to determine the appropriateness of the limited or confined site for the proposed uses and the information recorded in the opportunities and constraints analysis.

(3) Alternative Plan Development. Alternative plans are developed as a tool for selecting the most desirable final location of site elements. The process for alternative plan preparation is virtually the same as that described in chapter 2 for ADP's, but requires more definitive decisions. Each alternative plan should be prepared in sketch form to scale. Figures 3-3, 3-4, and 3-5 illustrate alternative site arrangements for the facility which meet the goals and objectives. Through this site planning process, detailed siting arrangement possibilities can be explored to achieve an optimal design that maintains the integrity of the approved ADP and/or master plan. The rationale for design

decisions made during alternative plan development should be recorded. Notations made directly on each of the alternative plans is an effective recording method. These records will be used to compare and contrast the plans in the selection of a preferred plan.

(4) Alternative Plan Evaluation. Upon completion of the alternative plan, a preferred alternative can be selected. The alternative plan notations and other records can be used to prepare a list of pros and cons for each alternative. These evaluations can then be used to compare the alternatives through the use of a matrix created to compare elements of each alternative plan. Figure 3-6 shows a matrix used to evaluate the alternative plans developed for the guest housing facility. Within the matrix, values are assigned according to how each alternative meets the requirements, goals, and objectives of the project facility.

a/ The alternative plan evaluation process requires comparison of conflicting project demands such as site constraints, ideal solutions, costs, and future expansion needs. The preferred plan will be the one that best addresses these demands while at the same time meets the project goals and objectives outlined at the outset of the Site Plan process. The selection of the preferred plan may require several iterations of alternative plans. The preferred plan may also be a composite of the most desirable aspects of several or all of the alternatives.

b/ The preferred plan selection process should be reviewed by the following personnel to evaluate the planning matrix, the assets and liabilities of each alternative plan and the recommended preferred alternative.

1/ Design team.

2/ Customer.

3/ User.

c/ The review personnel should reach a consensus for selection of the recommended preferred plan or an alternative solution to the preferred plan. If an alternative solution is selected, the review personnel should prepare a definitive analysis of the assets and liabilities of the alternative solution that led to selection over the preferred alternative. The preferred plan must be presented to and approved by the Installation Commander and the Installation Planning Board as the final step in the selection process.

(5) Final Site Plan. Preparing a final Site Plan is the result of the alternative plan evaluation.

(a) Preliminary Site Plan. The preliminary plan will be prepared as a sketch plan. The Preliminary Site Plan will be presented to the installation review team for review and approval before the final Site Plan is prepared. The preliminary Site Plan will show the location of all program elements on the site and indicate land use, circulation, utilities, and access for the site. Figure 3-7 illustrates a typical preliminary Site Plan for the guest housing facility development site.

(b) Final Site Plan. The final Site Plan is prepared from the approved Preliminary Site Plan. In the final Site Plan, the program elements, land use, circulation, utilities, and access are developed in more detail. Figure 3-8 depicts a final Site Plan for the facility development site. The

following information may be included in the final Site Plan.

1/ Location Plan. The location plan can be included as an inset on the Final Site Plan sheet or as a separate drawing. The purpose of the location plan is to illustrate the location of the development area in relation to the surrounding activities.

2/ Final Site Plan. The plan will include a series of plans and maps that depict the final plan configuration as follows:

a/ Site Plan.

b/ Landscape Plan.

c/ Utility Plan.

c. Implementation. AR 415-15 identifies project development and execution procedures. The site plan provides the location, arrangement, and size of all the various elements of the facility. After the site plan is prepared, the architectural and engineering construction plans, specifications, quantity take-offs, and cost estimates will be prepared.

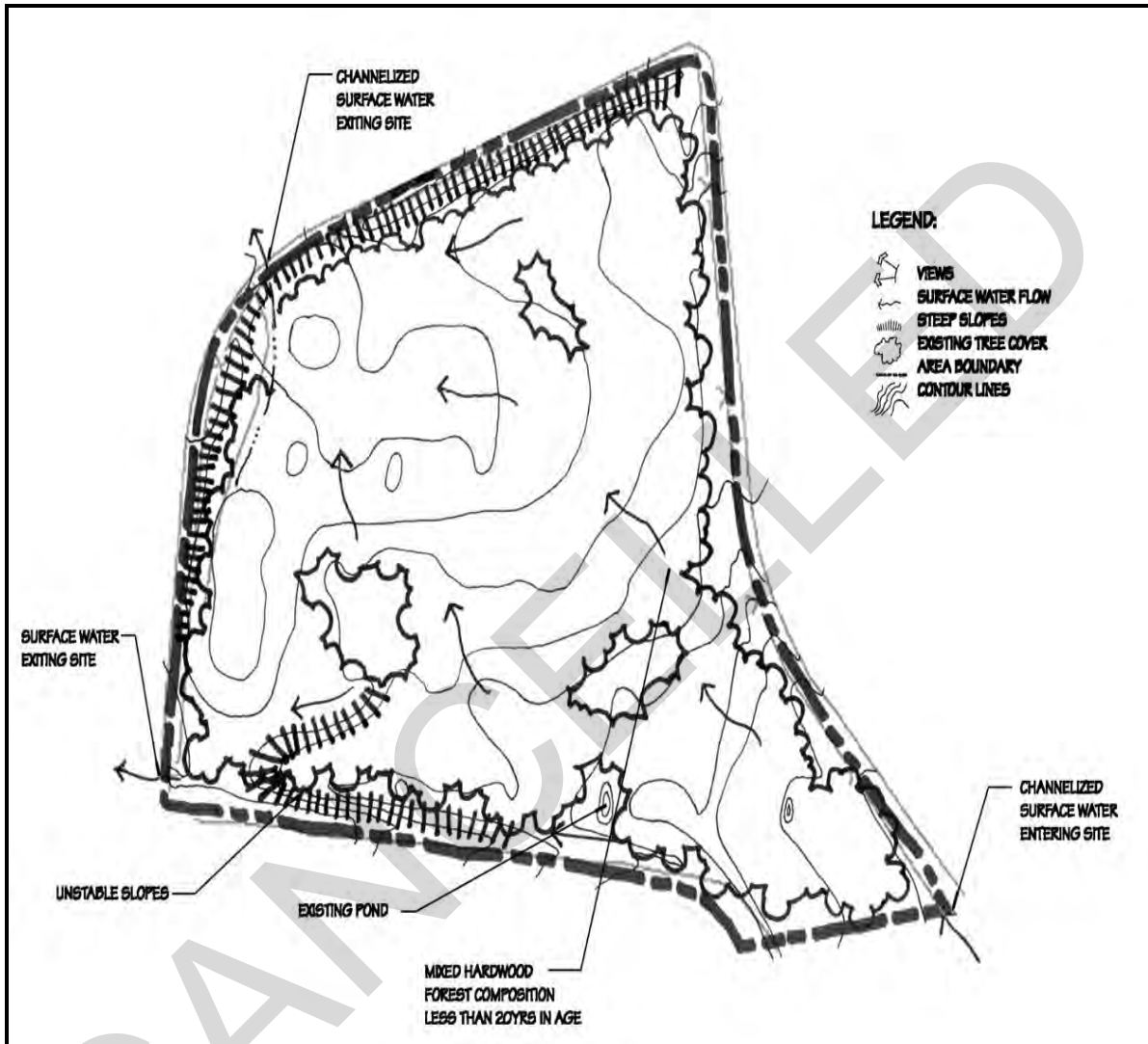

Figure 3-1. Analysis of natural environment

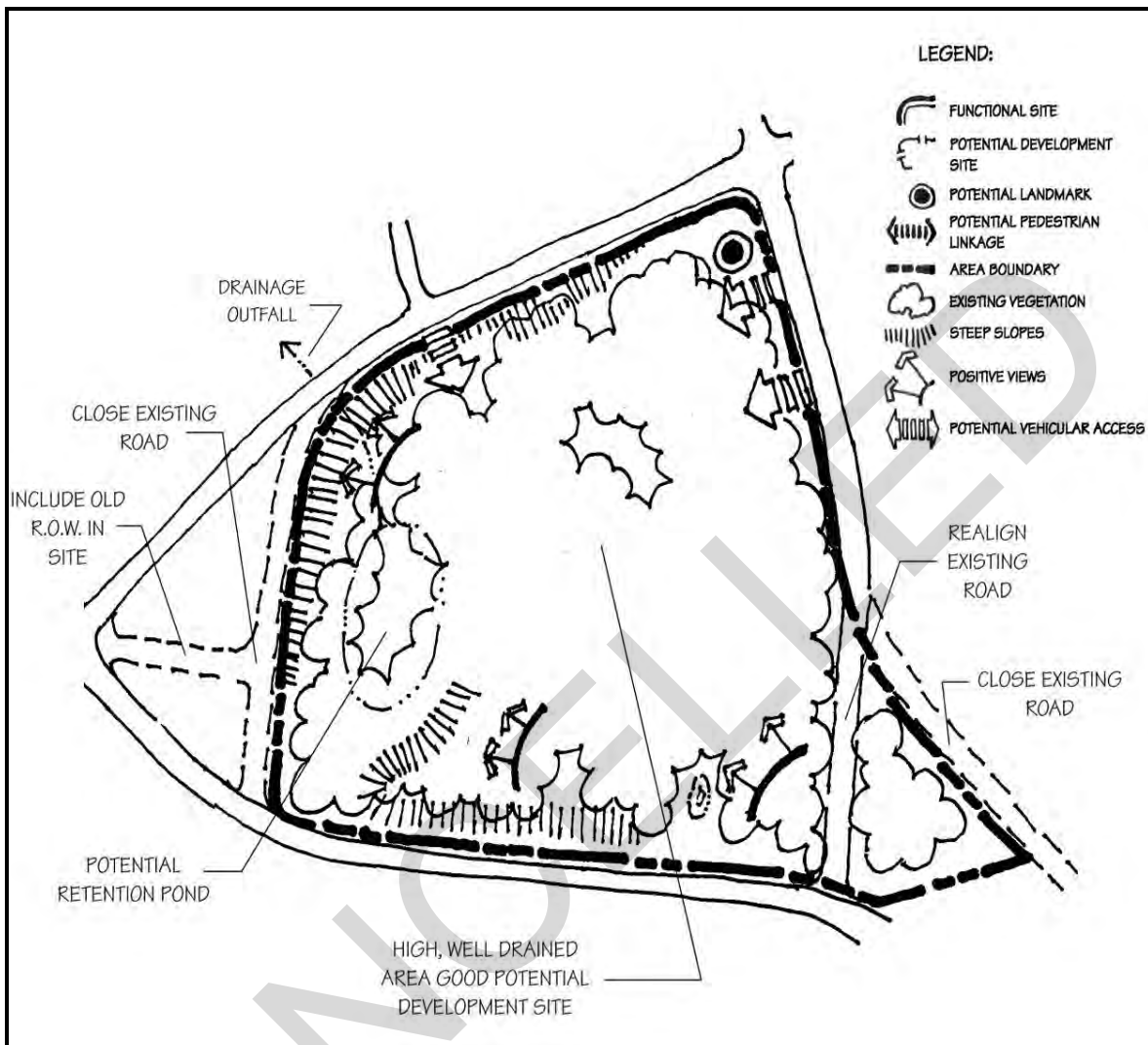

Figure 3-2. Site opportunities and constraints

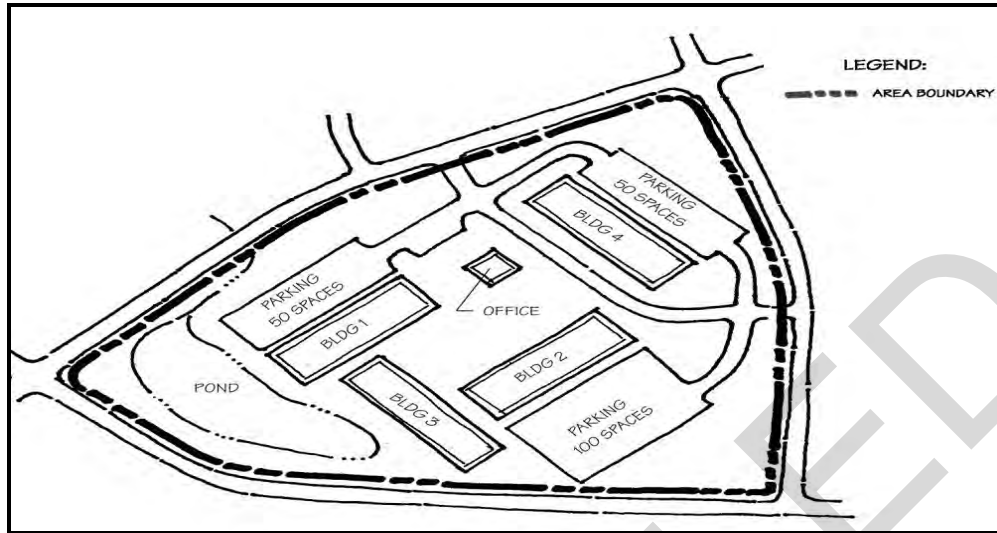

Figure 3-3. Alternative 1

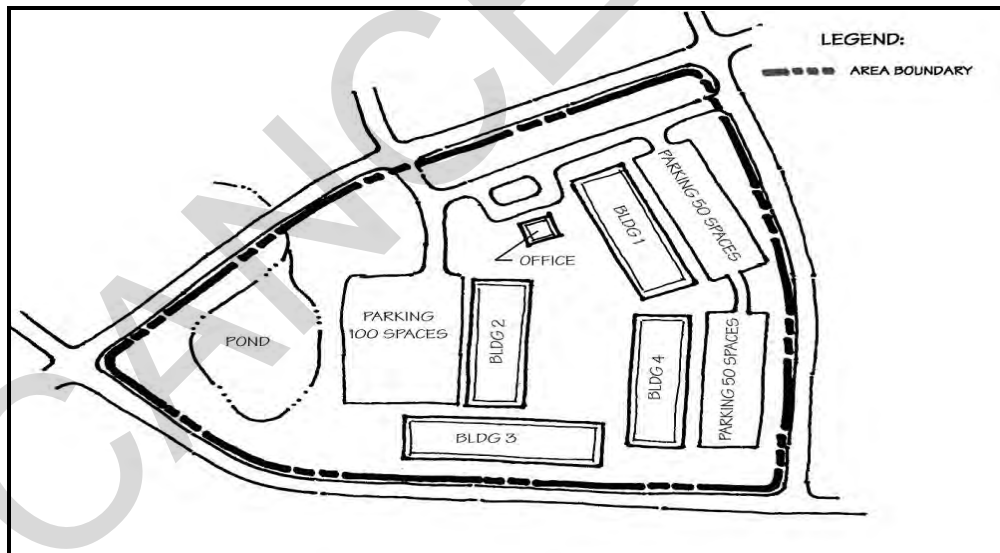

Figure 3-4. Alternative 2

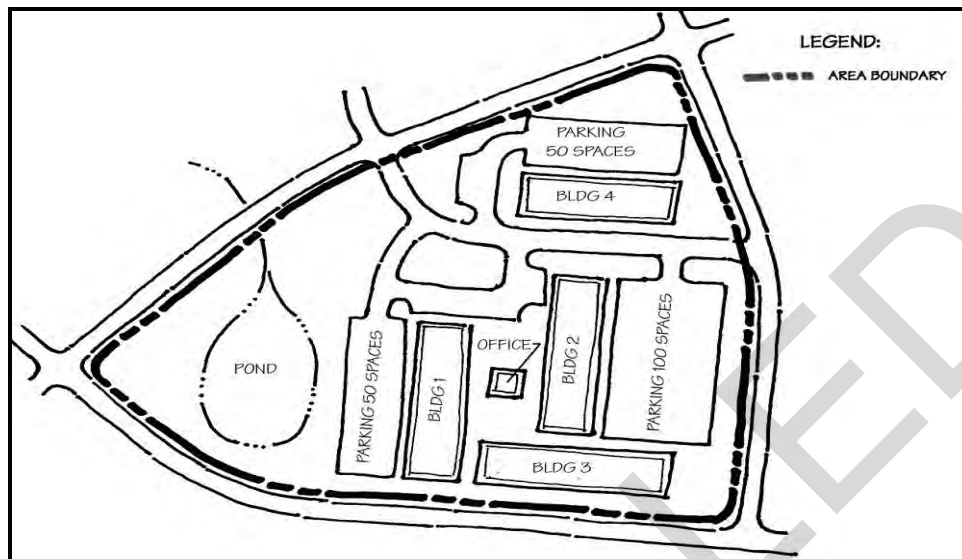

Figure 3-5. Alternative 3

	Alternative 1	Alternative 2	Alternative 3
Provide adequate parking for new facilities	1	1	1
Provide parking with easy access to all rooms	3	2	1
Protection of all Environmentally Sensitive Areas	2	3	1
Modify vehicular circulation to lower accident frequency	3	1	1
Provide connecting roadway	1	5	1
Locate office central to rooms	1	5	2
Modify vehicular access to the site	2	3	1
Separate pedestrian and vehicular circulation	3	3	3
Minimize disturbance to site	1	3	1
TOTALS	17	26	12

(1=Good, 5=Poor)

Figure 3-6. Site evaluation matrix

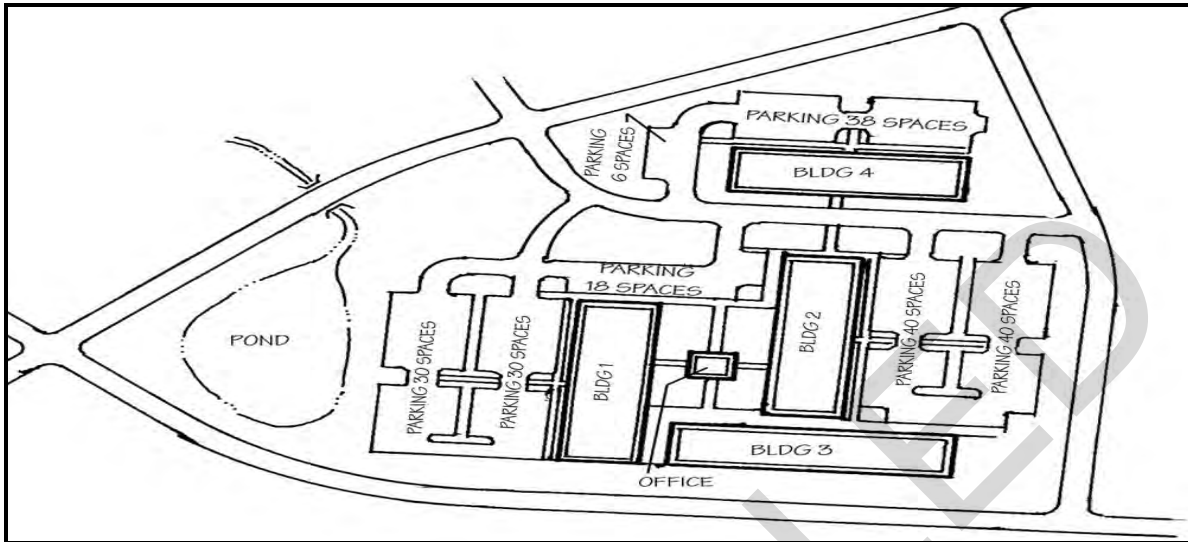

Figure 3-7. Preliminary site plan

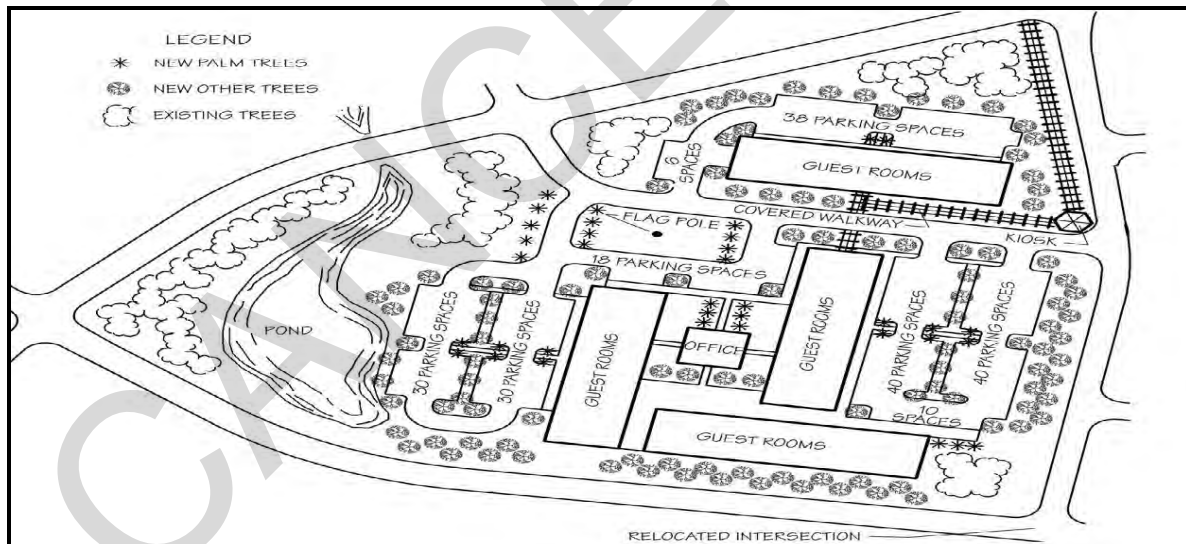

Figure 3-8. Final site plan

CHAPTER 4

DESIGN CRITERIA

4-1. GENERAL. This chapter provides guidance concerning certain design criteria to meet the requirements for design layout. Additional design criteria can be found in the Architectural and Engineering Instructions, Design Criteria and in the Installation Design Guide (IDG). Design criteria should be incorporated into the planning process from the onset. The design criteria should be used during the planning process to provide the requirements that affect the spatial relationships.

4-2. BUILDING DESIGN, LOCATION, AND ORIENTATION. The primary building is usually the most prominent single element and the center of site activity. The building location on the site may be determined by considering the following factors.

a. Dimensional Factors. Dimensional factors include the building dimensions, or footprint, and the following factors:

(1) Buffer Zones. Buffer zones provide setbacks and safety protection from:

- (a) Airfield and helipad clearances.
- (b) Explosives safety clearances.
- (c) Noise abatement.
- (d) Physical security clearances.
- (e) Storage and handling hazardous material clearances.
- (f) Separation of incompatible land use or functions.

(2) Spacing Requirements. Spacing between buildings and functions is normally determined by their:

- (a) Functional relationships.
- (b) Operational efficiency.
- (c) Fire protection clearances.
- (d) Physical security requirements.
- (e) Parking requirements.
- (f) Future expansion.
- (g) Open space.

(3) Setbacks (see figure 4-1).

(4) Facility Proximity. A building should be located in accordance with its spatial and functional relationship to its support facilities and to other primary facilities.

(5) Buildable Area. The buildable area is that area established on the site survey for the location of a structure or structures determined in the site analysis and the following guidance (see figure 4-1).

b. Environmental Factors. The location and condition of such elements as geology, soils, drainage, and vegetation may create areas that should be excluded from development because:

- (1) They are unbuildable for structural, economic or environmental reasons.
- (2) They require protection.
- (3) They require preservation.

c. Orientation Factors. Building location may be influenced by orientation to enhance energy conservation.

(1) Solar. Energy conservation criteria is provided in the AEI. Life Cycle Cost Analyses (LCCA) should be provided as required. Special energy conservation studies for nonrenewable resources should be accomplished as required. As illustrated in figure 4-2, these analyses and studies should provide an orientation for facilities to be energy efficient.

(2) Other Siting Factors. Other site-specific conditions can influence building alignment.

- (a) Ability to accomplish the mission.
- (b) Ability to minimize travel time.
- (c) Ability to control access.
- (d) Orientation to a slope (figure 4-3).
- (e) Orientation to take advantage of or reduce the impact of prevailing winds (figure 4-4).
- (f) Microclimate impacts.

d. Visual Factors. The visual survey accomplished during the site visit should provide requirements to reduce negative visual impressions. The elements to be retained or enhanced should be included in the design. The AEI and IDG provide additional guidance (figure 4-5).

4-3. VEHICULAR CIRCULATION AND PARKING. Circulation should promote safe and efficient movement of vehicles and pedestrians. Maintaining maximum separation of vehicles

and pedestrians helps promote safety. Safe circulation systems have a perceivable hierarchy of movement, lead to a clear destination and do not interrupt other activities. EI 02C800, Design for Non-Organizational or Privately Owned Vehicle (POV) Site Circulation and Parking, provides specific design criteria for vehicular circulation and parking. The AEI provides guidance concerning design vehicle and space allowance and parking stall size. The AEI also provides authorized parking allowances for non-organizational vehicle (POV) and visitor parking allowances by facility type.

a. Vehicular Circulation. The following factors should be considered in the design of vehicular circulation:

(1) Access Intersections. Driveway intersection access should be controlled to minimize the conflicts between through traffic and vehicles entering and exiting the site. Points of conflict can be limited by:

(a) Reducing the number of access drives to one (1) two-way drive or a pair of one-way drives for each site. Drives may be added to the site if the daily traffic volume exceeds 5,000 vehicles per day (both directions) or if traffic using one drive would exceed the capacity of a stop-sign-controlled intersection during the peak (highest) traffic hour.

(b) Increasing the space between drives and between drives and roadway intersections.

(c) Preventing certain maneuvers (e.g., left turns).

(d) Provide left-turn lanes with storage for turning vehicles.

(e) Provide right-turn deceleration and acceleration lanes for right turning vehicles.

(f) Include physical and sight distances which allow safe entry and exit from the access road.

(g) Location away from any elements (e.g., building, topography or vegetation) which block or lessen sight distance.

(h) Adequate views and signage of entry to the site from the access road.

(i) Use of topography, vegetation, and water to define entrances.

(j) Maintenance of maximum spacing between access drives occurring on the same access road.

(k) Alignment of access drives across the primary roadway from each other, or adequate separation of access roads.

(l) Right-angle turns from the access road onto the access drive with adequate turning radii.

(m) Depending upon the size of the project, marginal or medial channelization.

(n) Adequate road width and length at entrances to channel vehicles smoothly into the proper lanes.

(o) Provisions for special use vehicles that require nonstandard turning radii and driveway widths.

(2) Driveways. Driveways provide access to the site to suit specialized needs. Driveway location, design, width, turning radii, terminus, etc., is dependent upon the proposed use and the required site distance. Figure 4-6 illustrates a typical plan for access driveway and vehicular circulation. Access drives should be designed to meet the following criteria:

(a) Take vehicles to their destination and return with minimum interference or travel through parking areas, service areas or emergency zones.

(b) Enter and exit the site at the same point or on the same access road to discourage through traffic on site.

(c) Accommodate two-way traffic since one-way systems can create confusion.

(d) Provide separation of service drives from emergency drives.

(3) Drop-off Areas. Drop-off areas should be provided for office, commercial, educational and community facilities with high use. Drop-off areas should be:

(a) Located at or near the front of the building apart from entries into parking lots.

(b) Designated to provide a separate drop-off area located away from the building for buses and shuttles.

(c) Preferably on a one-way loop to avoid confusion.

(d) Sufficient in size to avoid vehicle conflicts and stoppages of traffic flow. Where a circular turn-around is used, the circle radius should be sized to support the design vehicle.

b. Parking. Parking should occur in lots or structures with a limited number of entrances and exits onto the access road or drive. Entrances and exits into different lots on the same site should be aligned or adequately separated to provide safe sight and maneuvering distances. Parking areas should provide:

(1) Barrier-free parking and pedestrian access must be provided to meet requirements of the Americans with Disabilities Act, Accessibility Guidelines for Buildings and Facilities.

(2) Locate parking within convenient walking distance of a building entrance.

(3) Parking for high turn-over or short-term use (e.g., visitor, outpatient or delivery) should be located in a separate lot or signed and placed nearest the entrance.

(4) Parking aisles aligned towards the building entrance to encourage more organized pedestrian flow and limited places where pedestrian traffic must cross vehicular traffic (figure 4-7).

(5) Parking should not require movement across vehicular paths in areas primarily designed for children such as Child Development Centers.

(6) Parking lot locations can have a strong heat and visual impact from reflected light on adjacent land uses.

c. Emergency Vehicle Access. Emergency vehicle access must be provided as follows:

(1) Emergency (rescue) vehicle access must be provided to all buildings.

(2) Fire truck access must be provided between buildings. This access may be provided on sidewalks, paths, or turf areas designed for the vehicle.

(3) If a special drive is installed to accommodate emergency vehicles, it must provide sufficient room for the vehicle to turn and exit the site and adequate support for the vehicle weight.

d. Service Vehicles. Service vehicles range in size from pickup trucks and vans to garbage and large delivery trucks. These vehicles generally require larger turning radii, more room to maneuver, and holding space while deliveries or service occurs. Service areas should be designed to provide space for the largest service vehicle that would use that area. Service traffic should be separated as much as possible from the traffic aisles of parking lots.

(1) Sanitation Vehicles. The circulation of sanitation vehicles is dictated by the locations of the dumpster pads. Figure 4-8 indicates the primary consideration in locating dumpster pads. Dumpster pads should be located to:

(a) Provide convenient access for pedestrians taking garbage to the dumpster.

(b) Provide direct, convenient access to vehicles emptying the dumpster that will allow the vehicle to drive or back directly to the dumpster with minimal maneuvering.

(c) Reduce visual impact.

(d) Include sufficient screening with plant material, fences or walls.

(e) Provide a continuous route when more than one pad is included.

(f) Be removed physically and visibly from building entrances and major vehicular and pedestrian circulation routes when the dumpster is located in the principal parking lot.

(2) Delivery Vehicles. Special zones for delivery vehicles should be placed in less visible areas of the site, such as the rear or sides of buildings. Space requirements vary according to the type and size of vehicle and the need to access loading docks. Maneuvering room should be provided to allow trucks to back up and turn around to exit the site or to allow

trucks to back up to the loading dock.

(3) Courier Service Vehicles. At least one parking space should be included at the primary or secondary entrance to the facility for courier service trucks.

4-4. PEDESTRIAN CIRCULATION. Pedestrian circulation involves the movement of people by non-motorized means. TM 5-822-2 provides guidance on the geometric design of walks. All pedestrian access shall be designed to meet the requirements of the Americans with Disabilities Act, Uniform Federal Accessibility Standards.

a. Pedestrian Desire Lines. Pedestrian circulation should be based on pedestrians' tendency to follow the most direct route when walking between two points. Figure 4-9 illustrates a typical desire line study. These studies are prepared as follows:

(1) Desire lines are drawn to anticipate pedestrian routes to prevent crisscrossing the site with sidewalks.

(2) Desire lines should be weighted according to the most traveled routes.

(3) More generous paved area should be provided at pathway intersections to allow space for congregation and circulation.

(4) Adequate reception area should be provided at entrances to buildings.

(5) Coordinate circulation routes with building layouts to discourage short cuts by personnel through buildings.

b. Grid, Curvilinear, and Organic Path Systems. Path systems are developed from the desire line study. The system should incorporate required and anticipated access. Three types of systems are suggested to meet varying site demands. All three systems provide functional access between facilities. Figure 4-10 illustrates alternative sidewalk schemes based upon the pedestrian desire lines defined in figure 4-9. Topography and vegetation can be used to direct movement and emphasize sight lines.

(1) A grid path system is composed of straight lines and right angles and tends to provide the most direct access between location. The grid system is appropriate in formal landscapes and in areas with strong architectural definition.

(2) A curvilinear path system is less formal and should be used to encourage pedestrian interaction with the landscape where direct access to facilities is not critical.

(3) Organic sidewalk systems are unique in that the sidewalk patterns are defined by the space outside of the sidewalk and therefore vary in width. Because of this, organic sidewalks are less formal and often respond to natural elements in the surrounding landscape.

c. Pedestrian Concentration. The space required to accommodate pedestrian movement increases at the point of origin and destination, where movement slows. Pedestrian movement is also interrupted when people meet, gather, wait, or sit. In areas of pedestrian concentration (e.g., building entrances, drop-offs and small outdoor spaces between

buildings), the space should be developed to accommodate these needs. General design techniques include:

- (1) Widening walkways at the points of origin and destination.
- (2) Providing adequate space for people to concentrate outside of the pedestrian flow.
- (3) Locating areas for people to sit on the edge or outside of the pedestrian flow.
- (4) Providing both shaded and sunny areas for people to congregate or sit.
- (5) Providing shelter at congregation areas, especially where waiting is anticipated.

d. Troop Formation Areas. Installations with training facilities require muster areas and circulation routes for troops marching in formation between classrooms, barracks, dining halls and parade grounds. These areas and walkways should be designed to provide adequate sizes and surfacing to accommodate personnel.

4-5. SURFACE WATER MANAGEMENT. The primary functions of surface water management are to establish positive drainage, prevent flooding of roadways, facilities and activities, and prevent erosion. Proper management techniques also provide storm water infiltration, habitat preservation, and recreational opportunities. Surface water management should be designed to replicate natural systems and maintain public safety, health and welfare. The guidelines discussed below refer to general on-site drainage design. Specific criteria developed by local and state agencies should also be consulted. The landscape architect, civil engineer, and hydrologist on the design team should collaborate to address drainage problems and solutions. TM 5-820-4 provides additional guidance on drainage design.

a. Impervious Surface. The placement of facilities on a site changes drainage conditions by increasing impervious surfaces, primarily rooftops and pavements. This results in a greater volume and velocity of water to be managed. The negative effects of impervious surfaces upon the landscape can be reduced through the following:

- (1) Avoid creation of unnecessary impervious surfaces.
- (2) Evenly diffuse drainage across the site. Avoid concentrating drainage at one point by dividing the site into more than one drainage basin.
- (3) Divide large expanses of impervious surface (e.g., a parking lot) into smaller areas to help control runoff, reduce the size of necessary drainage structures (e.g., catch basins), and avoid drainage system back-up. Use areas in between divided spaces for infiltration and introduction of appropriate plant material.
- (4) Use Islands, medians, curbs and gutters to control drainage within parking areas. Curbs strategically allow introduction of runoff into designated catch basins for temporary storage or infiltration.

(5) Consider porous surfaces that allow infiltration (e.g., porous asphalt and concrete, gravel, open-cell paving systems, and turf) as paving alternatives.

b. Grading. Topography is the primary determinant in the amount, direction and rate of runoff. Existing drainage patterns should be maintained where possible to preserve topsoil. Facilities and parking areas should be sited to take advantage of existing topography (figure 4-11). Graded slopes should be gradual and avoid abrupt changes in gradient. Where graded slopes meet the existing topography, they should blend into the existing slope. The AEI provides guidance concerning slope gradients.

c. Positive Drainage. Positive drainage should be provided universally across the site. Figure 4-12 illustrates the following basic principles:

- (1) Direct water away from structures.
- (2) Do not allow water to pond at low points or in low areas.
- (3) Locate the finished floor elevations of buildings so that if drainage structures are blocked, the water will not back up into the buildings.
- (4) Direct water concentrated in parking lots and along curbs away from major pedestrian areas and routes.

d. Drainage Control. Storm drainage from buildings and other impervious surfaces must be directed to a storm drainage system. This water must be kept from infiltrating into the soils and causing foundation problems for the buildings. It also must be directed away from pedestrian walkways where it causes walking hazards. Runoff should be directed away from landscaped areas not designed to accommodate Storm water runoff to keep from drowning plant material and washing away mulch. Drainage can be controlled, captured and redirected using various methods.

(1) Vegetated swales and ditches are effective in cost and function for moving moderate amounts of runoff. It is recommended that these have a minimum gradient of 2.0% to maintain positive drainage.

(2) Paved swales and ditches are recommended to have a minimum gradient of 1.0% to maintain positive drainage.

(3) Check dams or weirs are used to slow water movement and increase infiltration in porous swales or ditches. Earth, stone, rip rap, gabions, and concrete are generally the best materials for dam and weir construction.

(4) French drains are a cost-effective means of directing small amounts of runoff. They can often be constructed by hand to correct post-construction drainage problems.

(5) Underground piping by way of sewer lines is the most expensive alternative in terms of materials, construction and maintenance cost. Underground piping is completely effective if the lines are sized correctly; however, changes to the system to suit future needs are difficult and expensive.

e. Detention Ponds, Retention Ponds, and Infiltration Basins. Detention ponds, retention ponds, and infiltration basins are drainage devices used to control the rate of runoff from the increased impervious surfaces resulting from construction. The increase in runoff is held within these ponds and slowly released at rates that are equal to or less than the rates that occurred before construction. The maintenance of pre-construction runoff rates helps prevent flooding, erosion and sedimentation of recipient drainage ways. Ponds and basins can be designed to allow collected runoff to stand long enough for heavier sediments to settle to the bottom, thereby reducing sedimentation downstream.

(1) Detention ponds release all of the collected water at a specific rate. Detention and retention ponds are especially useful during construction when the lack of drainage systems and vegetative cover make it difficult to control Storm water flow and erosion.

(2) Retention ponds function the same as a detentions ponds except they are designed to retain a certain level of water permanently and release all of the collected water above the permanent level at a specific rate.

(3) Infiltration basins retain all of the collected water until it infiltrates or evaporates. Infiltration basins are important for increasing groundwater recharge, especially in highly urbanized areas. Typically, infiltration basins are wide and shallow to facilitate rapid infiltration and evaporation. Basin floors are graded at 0 percent or close to 0 percent and have a permeable base. Infiltration basins are designed to be dry when not in use and can serve other functions as well, such as athletic playing fields.

(4) Local, state and federal jurisdictions are more frequently requiring the use of detention/retention and infiltration ponds a means of maintaining water quality. Requirements for designing detention ponds, retention ponds, and infiltration basins should be verified by local and state agencies.

(5) These ponds and basins should be designed to serve other functions in a development such as a water feature, wildlife habitat, wetland, and wastewater reclamation.

f. Erosion Control. Erosion control evaluation and implementation begins with identifying the causes of erosion and then implementing controls to limit erosion.

(1) Erosion occurs as the result of:

(a) Lack of vegetative cover.

(b) Excessively steep slopes.

(c) Excessive runoff.

(d) Unstable soils.

(e) A combination of the above.

(2) Erosion control can be improved by:

- (a) Reducing slope gradients.
- (b) Using geotextiles as filtering fabrics.
- (c) Establishing or reestablishing vegetative cover.
- (d) Introducing mechanical controls such as riprap, gabions, terracing and cribbing.

(3) Banks with steeper than 3:1 slopes are discouraged because they increase the rate of runoff and erosion. When an area involves steep grades, solutions such as retaining walls should be used to reduce erosion and maintenance. Figure 4-14 illustrates methods of erosion control.

4-6. UTILITY SYSTEMS DESIGN. Utility systems should minimize impact to the natural site while meeting basic economic and functional criteria. The AEI provides guidance concerning utility design. Utility systems should be located as follows:

a. Utility corridors should be used to minimize environmental disturbance and simplify maintenance. These corridors should be located along a site's perimeter and not cross a site diagonally or indiscriminately because future realignment of existing systems will increase the costs of future development.

b. Utilities should be placed underground wherever possible to:

- (1) Avoid conflicts with vegetation
- (2) Provide protection from storm damage.
- (3) Enhance the visual quality of the installation

c. To simplify maintenance, utility lines should not be placed under paved areas, but located at the back of the roadway curb. It is extremely important to determine the potential for future expansion and to allow for upgrading the system when locating utilities.

d. Utility transformers and trans closures for underground utilities shall be located to ensure ease of access for maintenance but not obstruct site primary visual relationships. They should be located with adequate setbacks from vehicular circulation and parking areas.

4-7. LIGHTING DESIGN. Outdoor lighting allows such activities as driving and walking to continue at night under safe conditions. On most sites, only enough light to illuminate these functions is necessary. Where physical security is a concern, more lighting may be required. Different types of lighting should be used to meet the needs of the site. The AEI provides guidance concerning electrical design.

4-8. LANDSCAPE DESIGN. Landscape design includes the preservation and enhancement of the environmental and visual quality including plant material, hardscape, lighting and signage. Landscape design is discussed in TM 5-803-13. The Installation Design Guide provides guidelines for installation preferences and establishes goals and objectives for the

visual environment. Landscape design should be considered as part of the total design process rather than as an addition of landscape plant material once construction is complete. Coordination with other elements of the process such as building design and placement, vehicular and pedestrian circulation, parking, lighting, and utilities is critical to the overall success of the project. When properly planned, landscape elements can be used for a variety of functions. Primary functions of landscape design include:

- a. Ecological/habitat preservation.
- b. Meeting environmental mitigation requirements.
- c. Screening incompatible land use or visually unacceptable elements.
- d. Modification of environmental conditions such as prevailing wind, sunlight, and excessive moisture.
- e. Physical and visual separation of spaces.
- f. Soften architectural elements.
- g. Visual enhancement.

4-9. PHYSICAL SECURITY. Site design for physical security should be developed to reduce vulnerabilities resulting from identified threats. References for physical security are TM 5-853-2, Security Engineering Concept Design; and TM 5-832-3, Security Engineering Final Design.

- a. General. Site design issues for physical security include:
 - (1) Determine level of threat.
 - (2) Maintaining adequate distances from uncontrolled areas.
 - (3) Limiting access to the site and facilities.
 - (4) Maintaining adequate standoff distances.
 - (5) Maintaining appropriate clear zones.
 - (6) Maximizing exposure on the site perimeter to allow discovery of unauthorized approaches.
 - (7) Minimizing exposure of personnel around the facility.
 - (8) Blocking sightlines from vantage points.
 - (9) Siting and orienting buildings to minimize adverse exposure.
 - (10) Providing barriers to unauthorized pedestrian and vehicle movement.

(11) Providing barriers to mitigate weapons and explosives effects.

(12) Providing exterior electronic security systems.

b. Vehicular Access. Where an identified threat indicates that vehicle control is necessary, access may be limited to specific entry control points that may include the following:

(1) Gate and/or gatehouse, vehicle barriers, or a combination of the two.

(2) Adequate room to permit search of vehicles without interfering with normal traffic flow.

(3) Horizontal and vertical alignment of drives which force a reduction in speed at the approach to the entry control point. Reduction of speed allows more reaction time to breaches of security and reduce the size of vehicle barriers required to stop a vehicle. Reaction time and the location of the barrier also affect whether there is sufficient time to deploy a barrier in response to a threat. Access drives and parking areas may need to be separated from facilities by sufficient distance to mitigate the threat of vehicle bombs.

c. Site Features. In an area where there is an identified threat, topography and vegetation should not obstruct views of surrounding areas.

(1) Topography, vegetation, water and walls can be used to:

(a) Slow movement towards exposed building faces.

(b) Limit exposure of personnel moving between buildings and parking areas.

(c) Block sightlines from vantage points.

(2) Perimeter walls may be used to mitigate blast effects from an explosion, but they must be carefully located with respect to the protected facility. If the perimeter wall is too far away from the facility, it may provide no benefit. If the wall is too close, it may compound the blast.

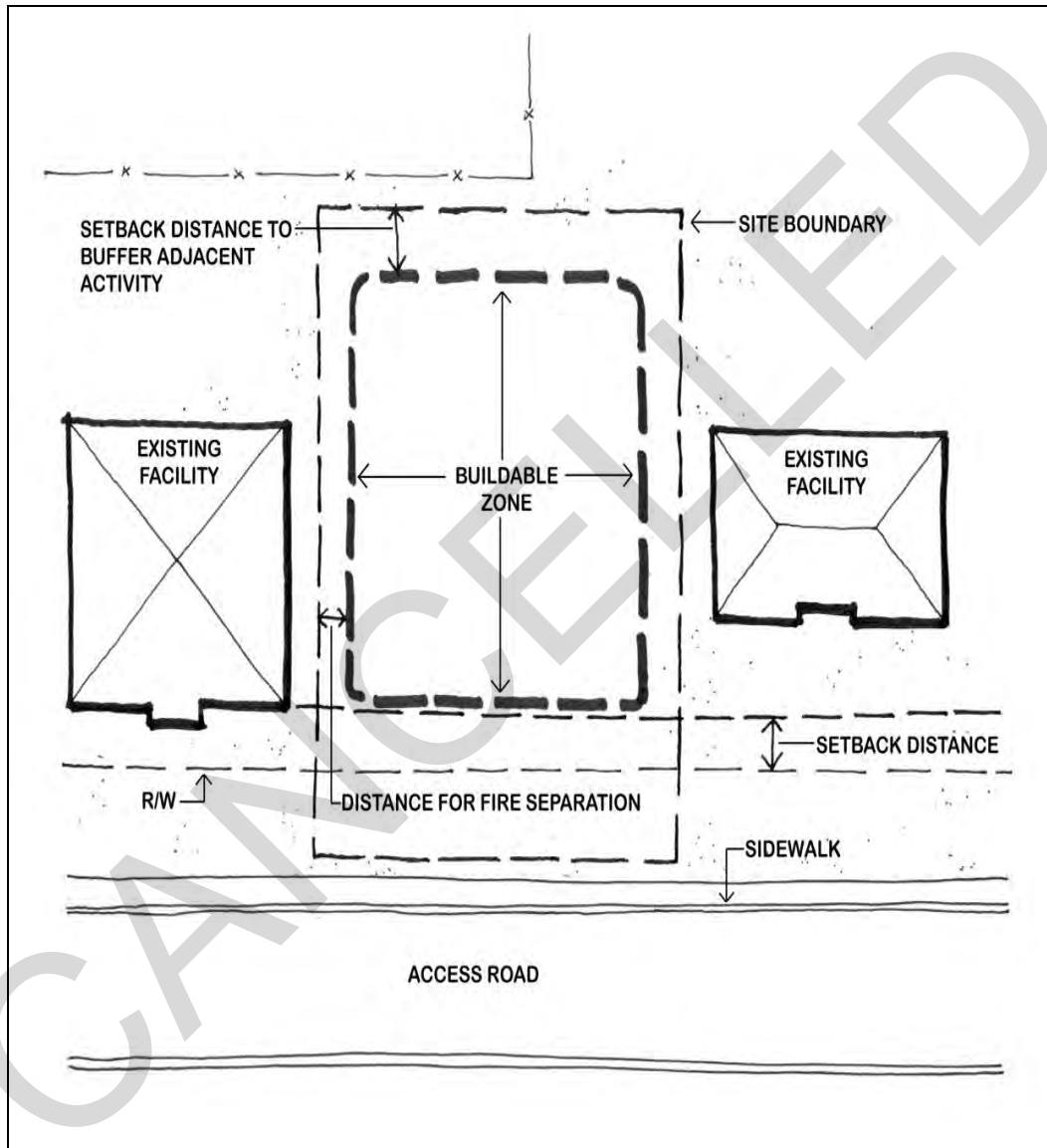

Figure 4-1. Dimensional factors

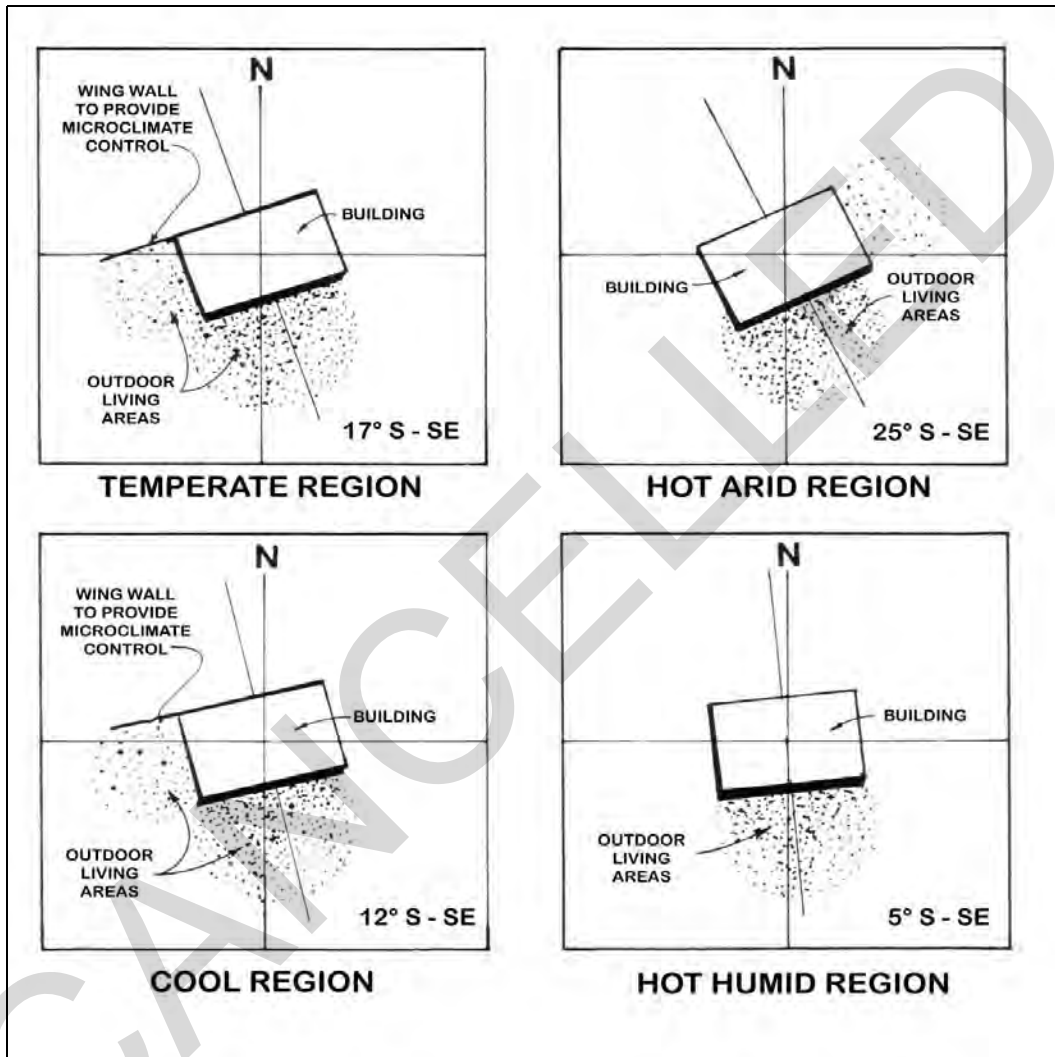

Figure 4-2. Solar orientation

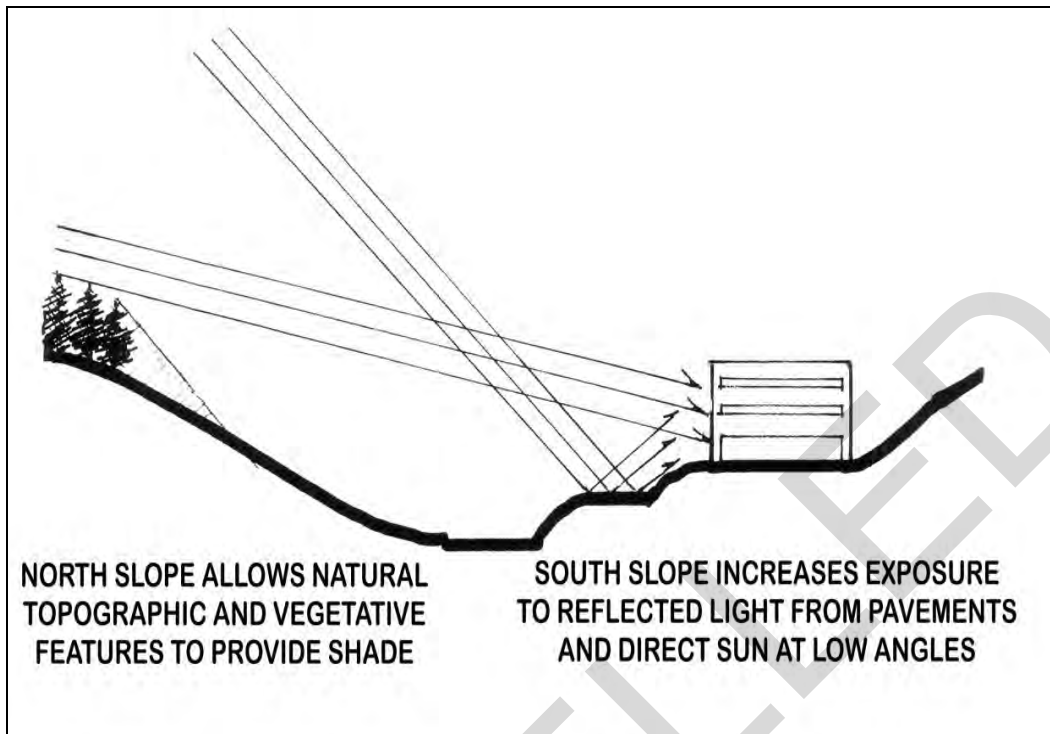

Figure 4-3. Slope orientation

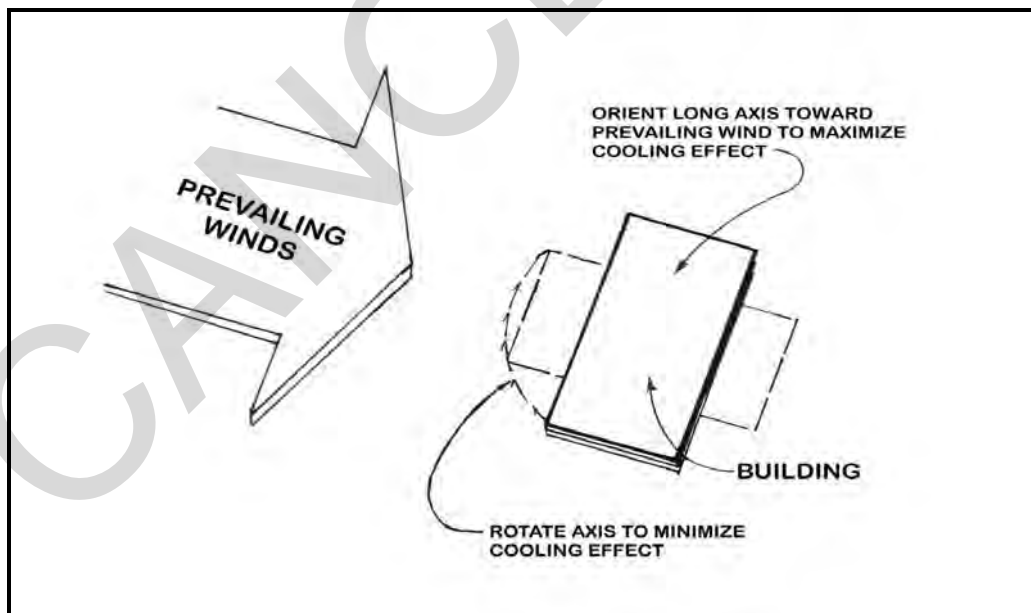

Figure 4-4. Wind orientation

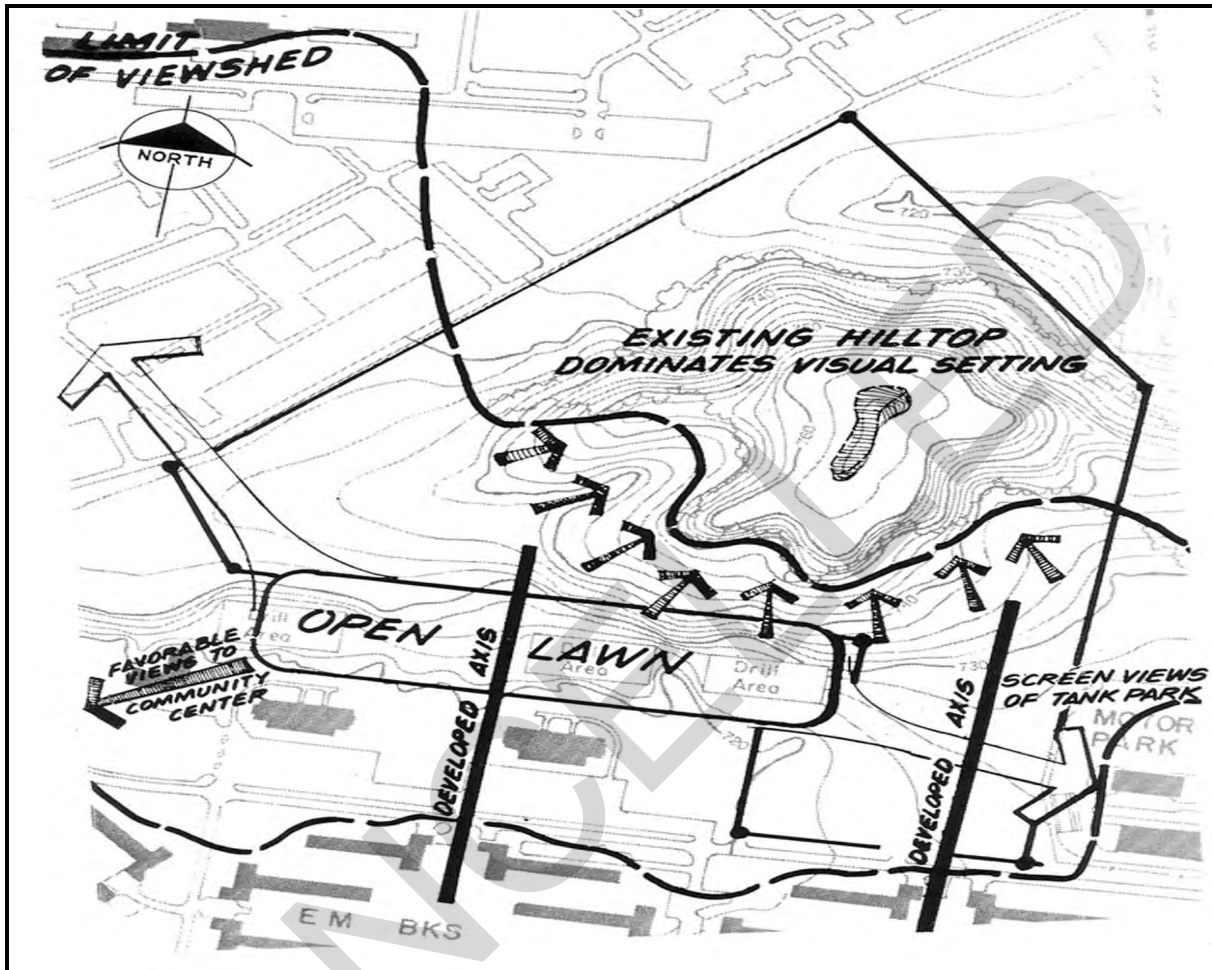

Figure 4-5. Visual factors

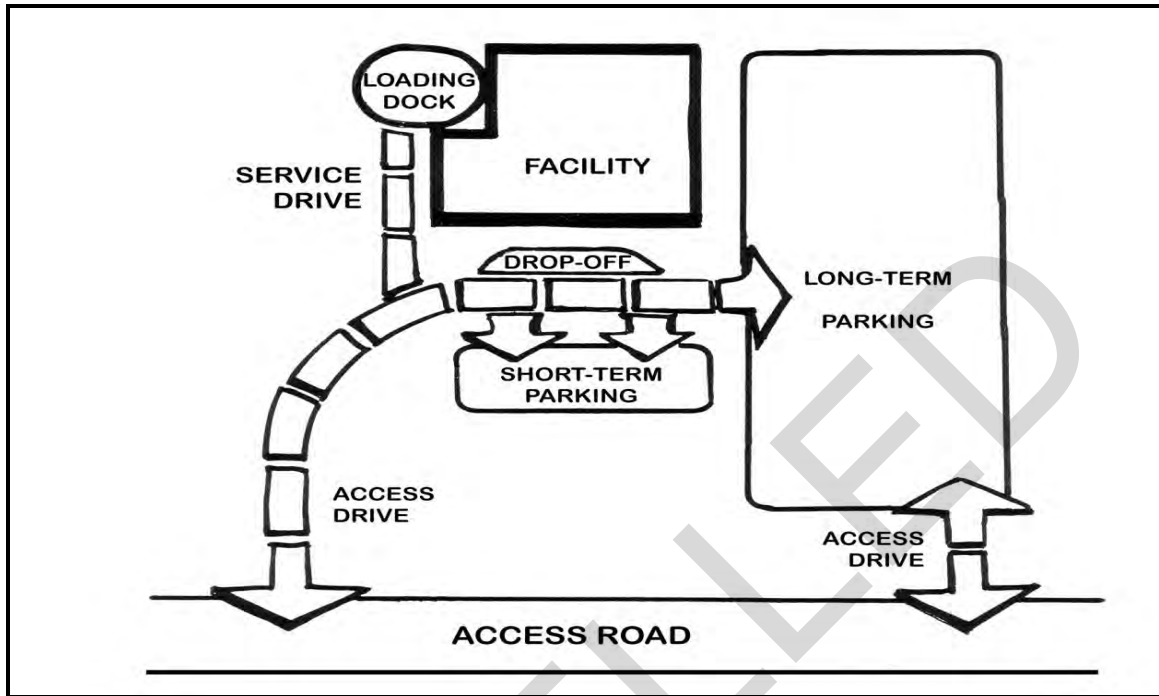

Figure 4-6. Vehicular circulation

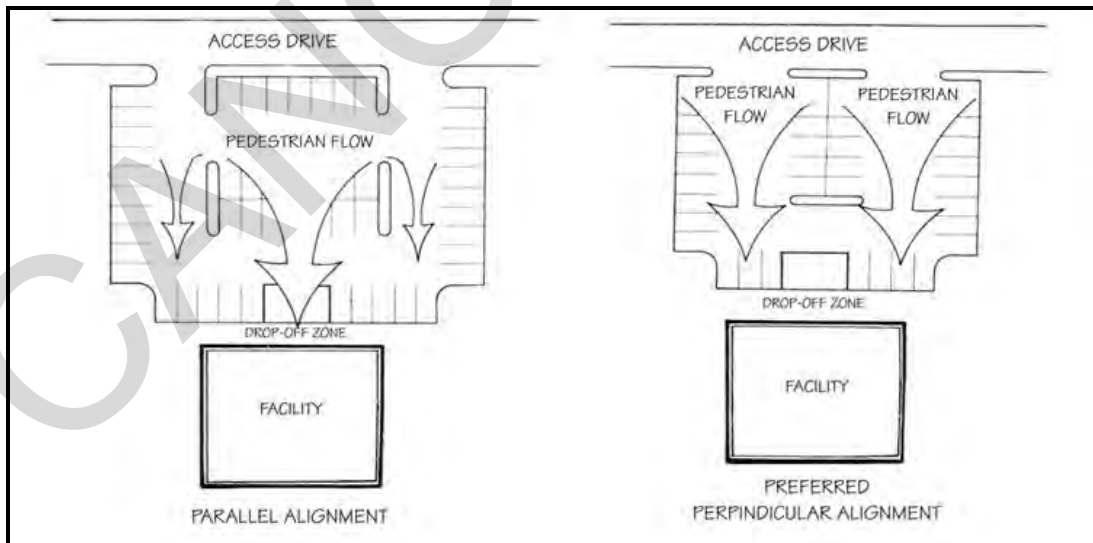

Figure 4-7. Parking

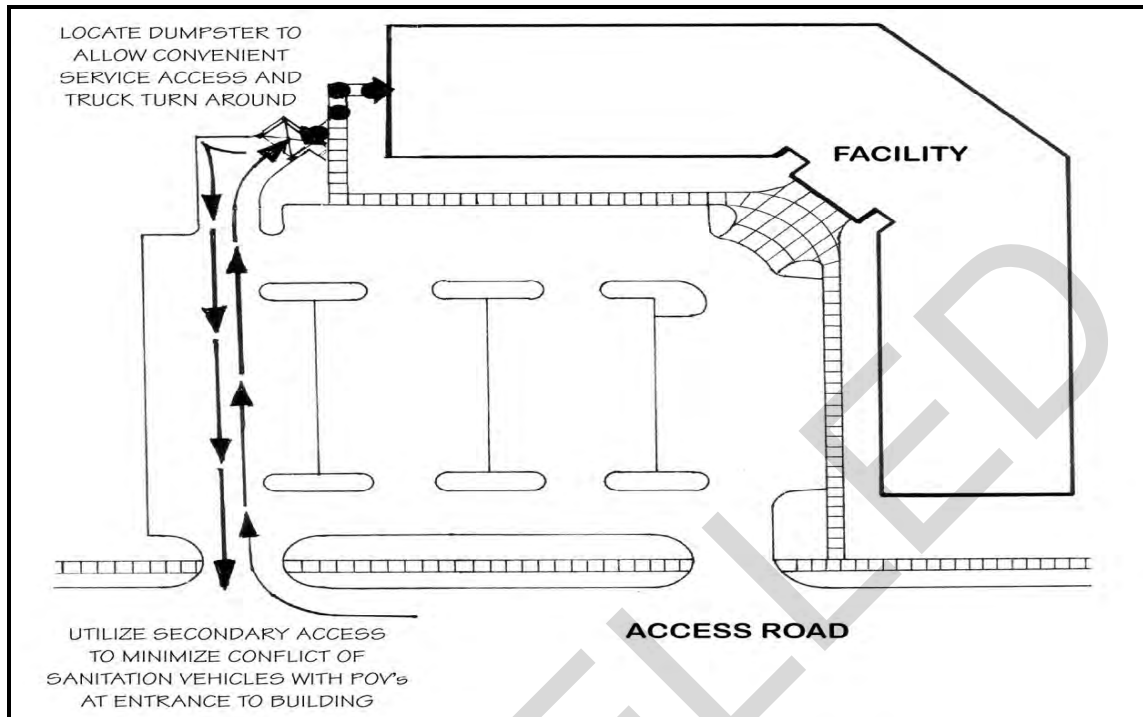

Figure 4-8. Dumpster location

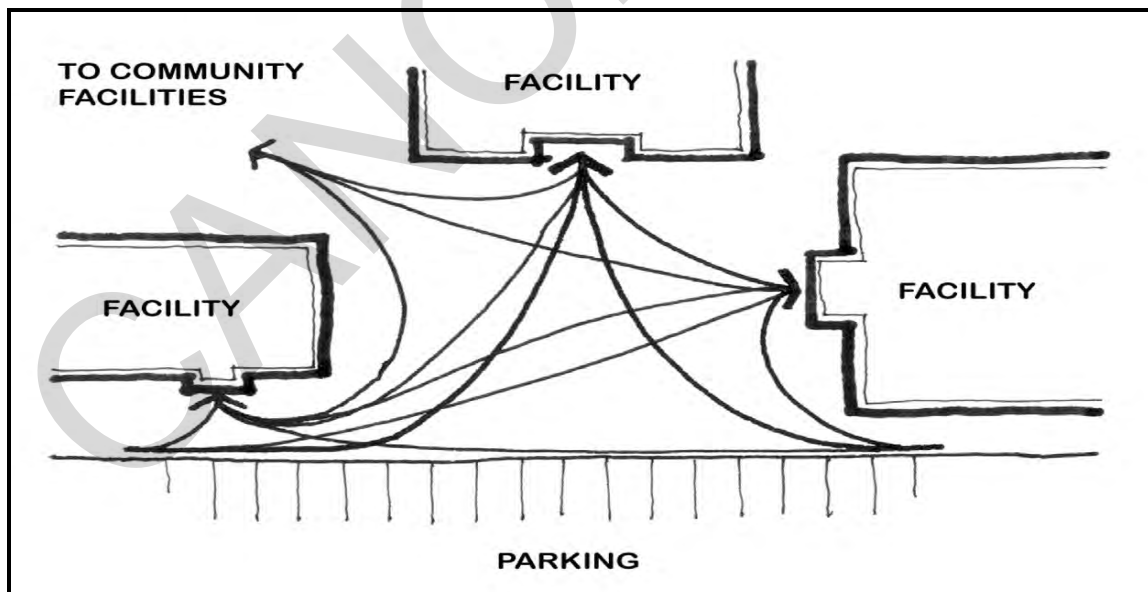

Figure 4-9. Pedestrian circulation

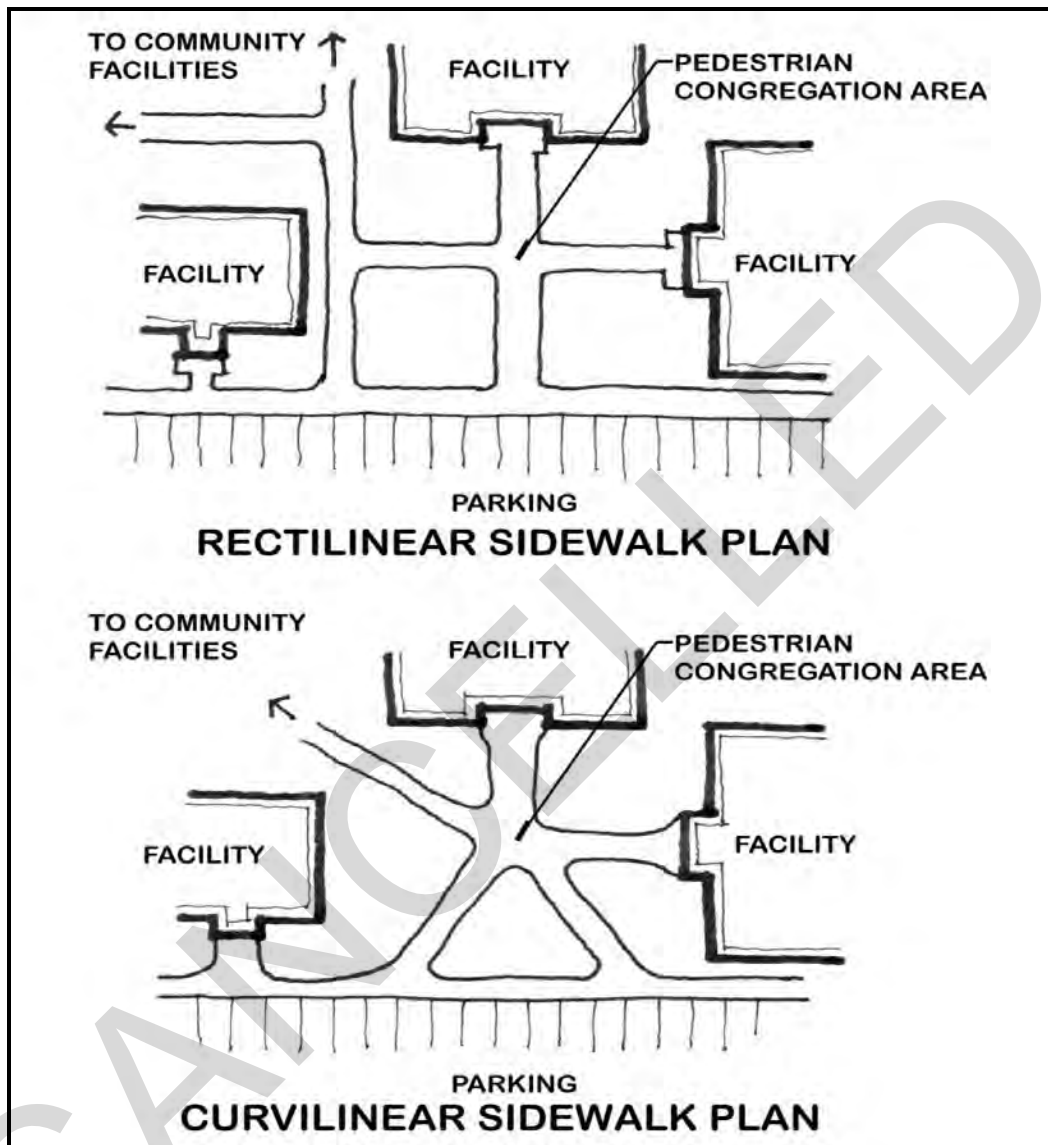

Figure 4-10. Sidewalk plans

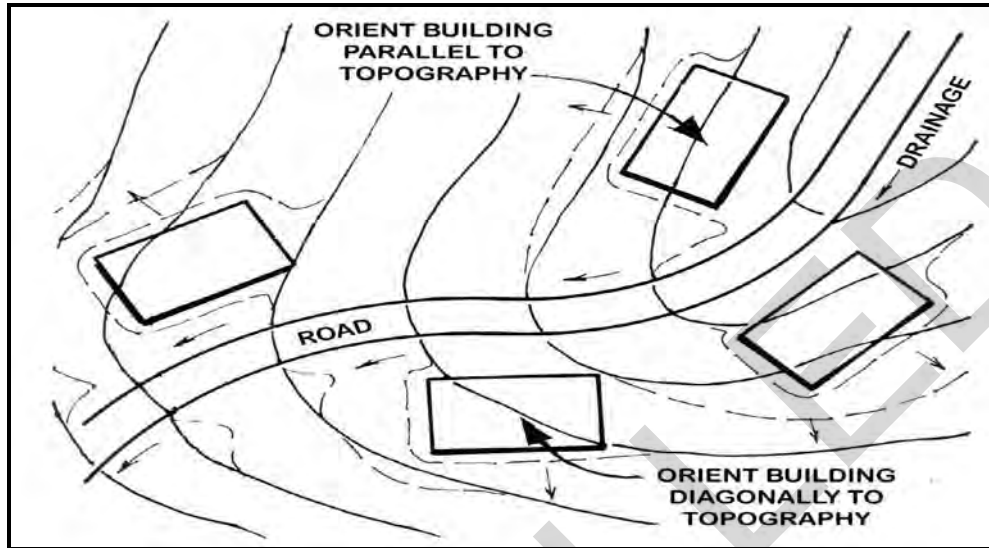

Figure 4-11. Minimize grading

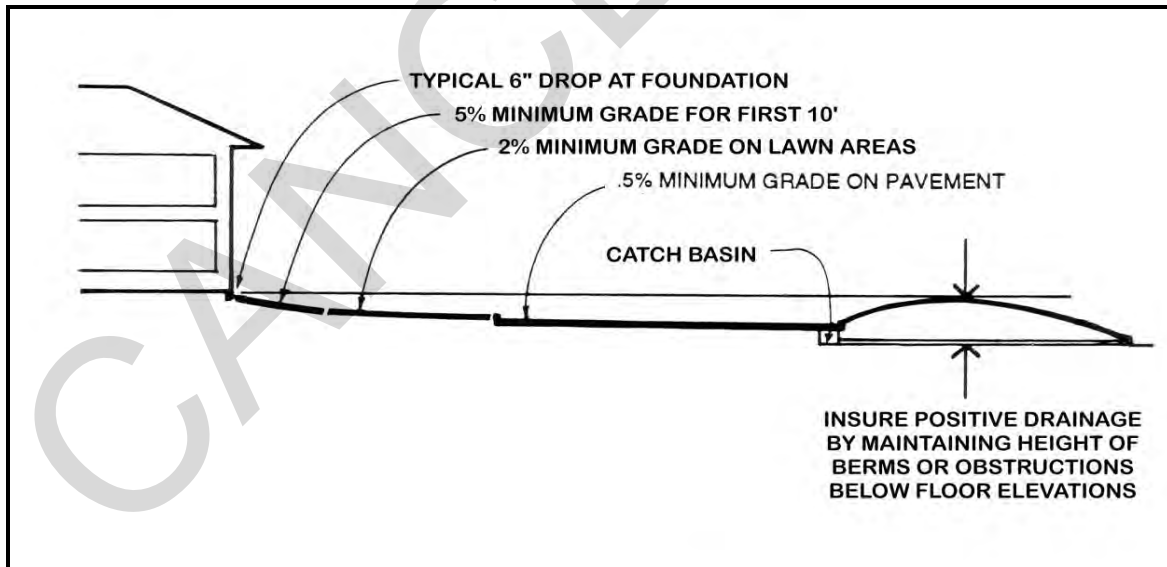

Figure 4-12. Surface water management

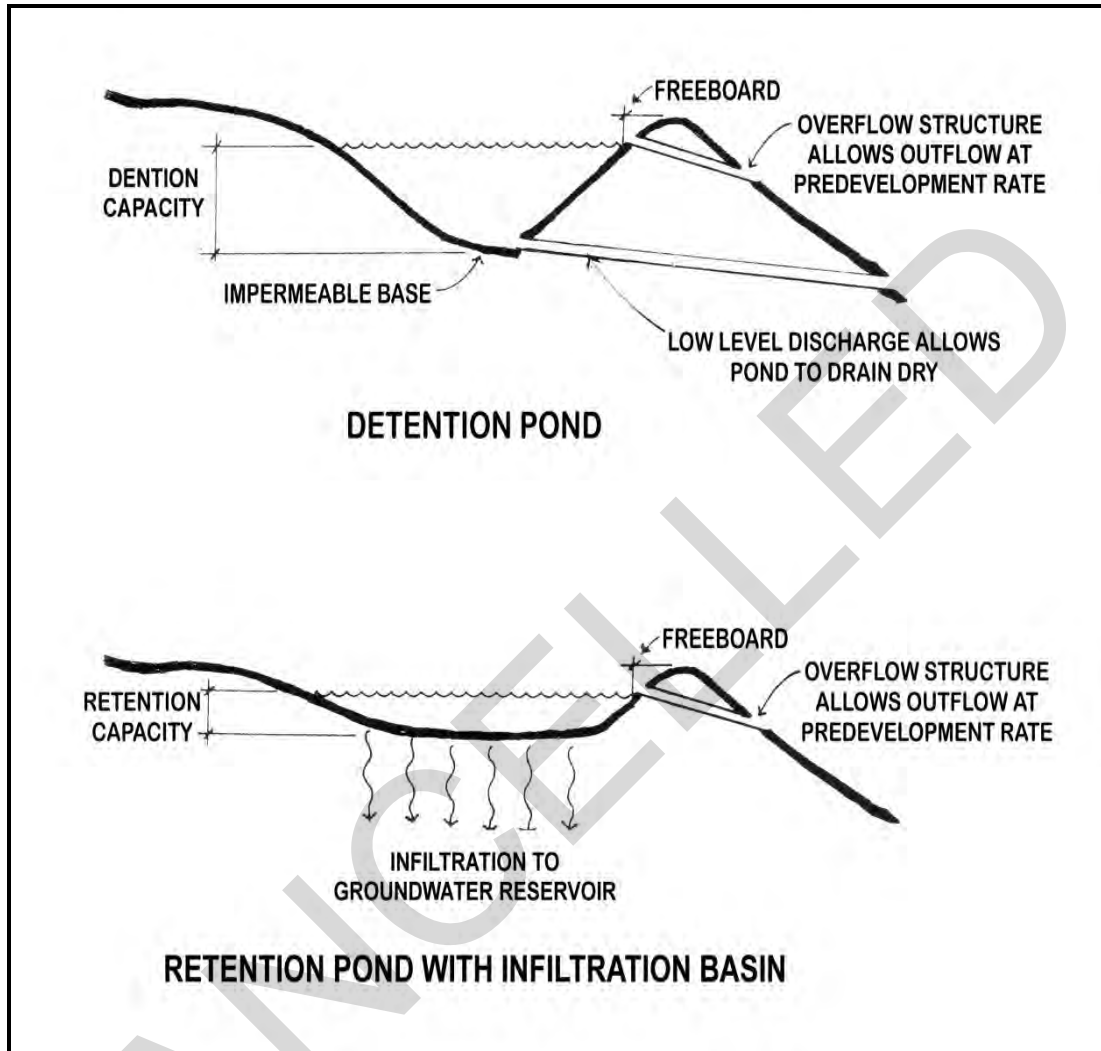

Figure 4-13. Detention, retention, and infiltration principles

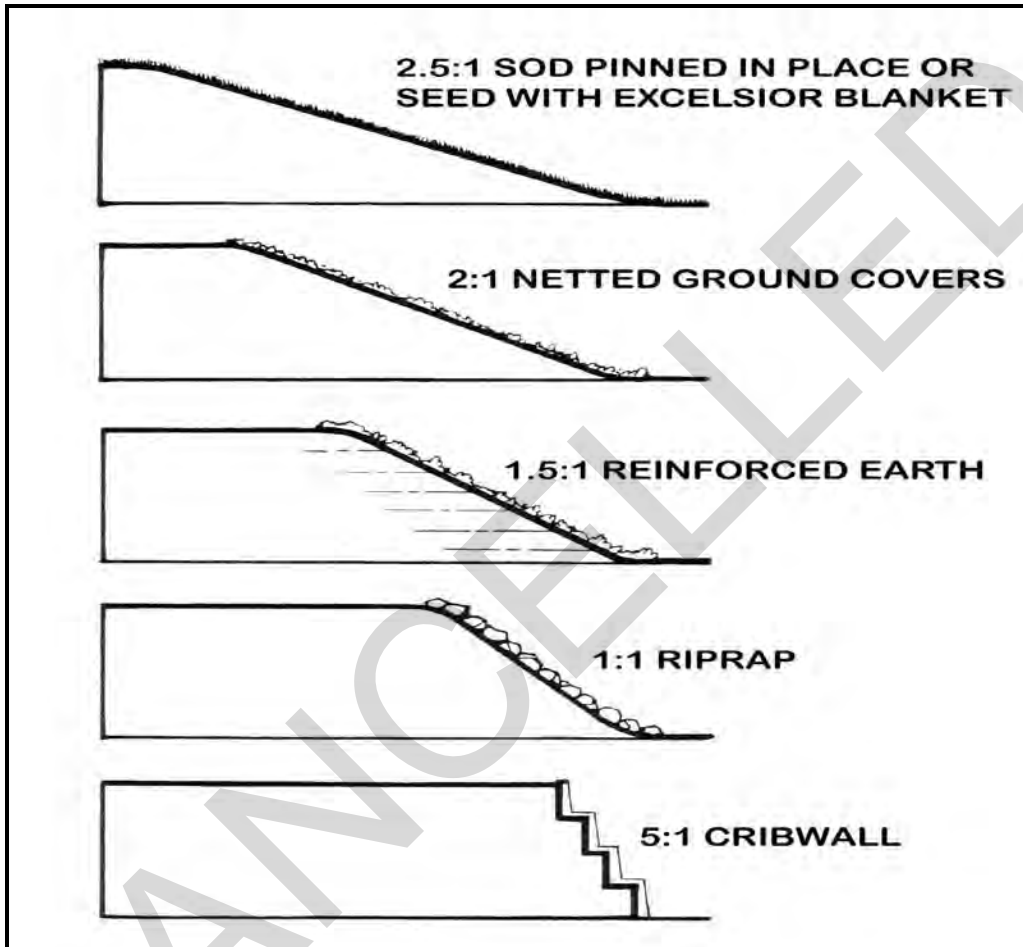

Figure 4-14. Erosion control

APPENDIX A

REFERENCES

A-1. GOVERNMENT PUBLICATIONS

a. Department of the Army

Civil Engineering Research Foundation. "Recommendations for Incorporating Green Building Concepts Into USACE Guidance Documents", Fall, 1995.

AEI	Design Criteria
AR 200-2	Environmental Effects of Army Actions
AR 210-20	Master Planning for Army Installations
AR 415-15	Military Construction, Army
EI 00X001	Engineering Instructions, Guidance Document
ER 1110-1-2	Engineering and Design - Quality Management
ER 1110-1-4	Engineering and Design - Metric Measurements
ER 1110-1-8152	Engineering and Design - Professional Registration
ER 1110-345-100	Engineering and Design - Design Policy for Military Construction
TM 5-11-1	Electric Power Supply and Distribution
TM 5-803-1	Installation Master Planning
TM 5-803-2	Planning in the Noise Environment
TM 5-803-5	Installation Design
TM 5-803-13	Landscape Design and Planting
TM 5-803-14	Site Planning and Design
TM 5-820-4	Drainage for Areas Other Than Airfields
TM 5-822-2	General Provisions and Geometric Design for Roads, Streets, Walks, and Open Storage Areas,
TM 5-832-3	Security Engineering Final Design
TM 5-853-2	Security Engineering Concept Design

b. Department of the Air Force

Office of the Civil Engineer, Area Development Planning Bulletin, October 1991.

c. Department of Justice

Americans with Disabilities Act, *Standards for Accessible Design*, Washington D.C.: July 26, 1991

A-2. NONGOVERNMENT PUBLICATIONS

American Association of State Highway and Transportation Officials (AASHTO). *A Policy on Geometric Design of Highways and Streets*, Washington D.C.: AASHTO, 1984.

DeChiara, Joseph. *Planning Design Criteria*, New York: Reinhold, 1969.

DeChiara, Joseph and Koppelman, Lee. *Site Planning Standards*, New York: McGraw Hill, 1978.

Harris, Charles W. and Dines, Nicholas T. *Time-Saver Standards for Landscape Architecture*, New York: McGraw-Hill, Inc., 1988.

Katz, Peter. *The New Urbanism*, New York: McGraw Hill, 1994.

Marsh, William M. *Landscape Planning*, 2nd ed, New York: John Wiley and Sons, Inc., 1991.

Ndubisi, Forster. *Planning Implementation Tools and Techniques*, Athens, Georgia: ICAD, 1992.

Ramsey, Charles G. and Sleeper, Harold R. *Architectural Graphic Standards*, New York: Wiley, 1970.

Rubenstein, Harvey M. *A Guide to Site and Environmental Planning*, New York: Wiley, 1969.

Steiner, Frederick. *The Living Landscape: An Ecological Approach to Landscape Planning*, New York: McGraw-Hill, Inc., 1991.

CANCELLED